

KENWOOD

SERVICE MANUAL

UHF DIGITAL BASE-REPEATER

TKR-D810

K, K2 versions

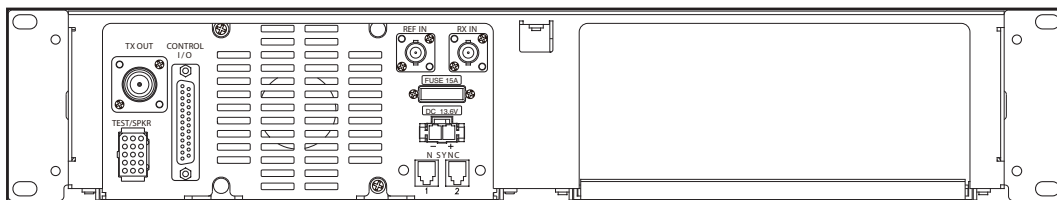
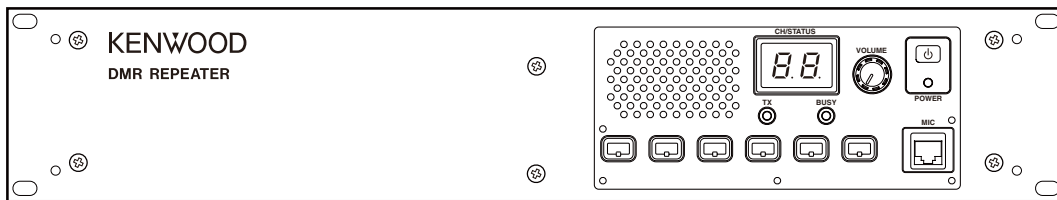

REVISED

This service manual has been revised due to the addition of TKR-D810 type K.

This product complies with the **RoHS** directive for the European market.



This product uses Lead Free solder.

TKR-D810

CONTENTS

GENERAL.....	3	TERMINAL FUNCTION	65
SYSTEM SET-UP.....	4	PC BOARD	
REALIGNMENT	4	FINAL UNIT (X45-4020-XX)	74
OPERATING FEATURES.....	6	CONTROL UNIT (X53-4580-10).....	78
INSTALLATION	7	DISPLAY UNIT (X54-4060-20)	82
MODIFICATION	9	TX-RX UNIT (X57-897K-XX)	86
DISASSEMBLY FOR REPAIR.....	10	RX VCO/PLL UNIT (X58-5210-XX).....	90
CIRCUIT DESCRIPTION	11	TX VCO/PLL UNIT (X58-5220-XX).....	91
COMPONENTS DESCRIPTION.....	20	INTERCONNECTION DIAGRAM	92
PARTS LIST.....	22	SCHEMATIC DIAGRAM	94
EXPLODED VIEW.....	46	BLOCK DIAGRAM	106
PACKING.....	48	OPTIONAL ACCESSORIES:	
TROUBLE SHOOTING.....	49	KES-5 (EXTERNAL SPEAKER)	109
ADJUSTMENT.....	54	SPECIFICATIONS.....	BACK COVER
		APPENDIX (SCHEMATIC DIAGRAM X53-4580-10)	

Document Copyrights

Copyright 2016 by JVC KENWOOD Corporation. All rights reserved.

No part of this manual may be reproduced, translated, distributed, or transmitted in any form or by any means, electronic, mechanical, photocopying, recording, or otherwise, for any purpose without the prior written permission of JVC KENWOOD Corporation.

Disclaimer

While every precaution has been taken in the preparation of this manual, JVC KENWOOD Corporation assumes no responsibility for errors or omissions. Neither is any liability assumed for damages resulting from the use of the information contained herein. JVC KENWOOD Corporation reserves the right to make changes to any products herein at any time for improvement purposes.

Service Manual List

Manual number	Model name	Type	Remarks
No.RQ149	TKR-D810	K2	First edition
No.RQ149<Rev.002>	TKR-D810	K,K2	Revised This service manual

Firmware Copyrights

The title to and ownership of copyrights for firmware embedded in KENWOOD product memories are reserved for JVC KENWOOD Corporation. Any modifying, reverse engineering, copy, reproducing or disclosing on an Internet website of the firmware is strictly prohibited without prior written consent of JVC KENWOOD Corporation. Furthermore, any reselling, assigning or transferring of the firmware is also strictly prohibited without embedding the firmware in KENWOOD product memories.

Transceivers containing AMBE+2™ Vocoder:

The AMBE+2™ voice coding technology is embedded in the firmware under the license of Digital Voice Systems, Inc.

GENERAL

INTRODUCTION

SCOPE OF THIS MANUAL

This manual is intended for use by experienced technicians familiar with similar types of commercial grade communications equipment. It contains all required service information for the equipment and is current as of the publication date. Changes which may occur after publication are covered by either Service Bulletins or Manual Revisions. These are issued as required.

ORDERING REPLACEMENT PARTS

When ordering replacement parts or equipment information, the full part identification number should be included. This applies to all parts: components, kits, or chassis. If the part number is not known, include the chassis or kit number of which it is a part, and a sufficient description of the required component for proper identification.

PERSONAL SAFETY

The following precautions are recommended for personal safety:

- DO NOT transmit if someone is within two feet (0.6 meter) of the antenna.
- DO NOT transmit until all RF connectors are secure and any open connectors are properly terminated.
- SHUT OFF this equipment when near electrical blasting caps or while in an explosive atmosphere.
- All equipment should be properly grounded before power-up for safe operation.
- This equipment should be serviced by only qualified technicians.

SERVICE

This transceiver is designed for easy servicing. Refer to the schematic diagrams, printed circuit board views, and alignment procedures contained within.

TKR-D810

SYSTEM SET-UP

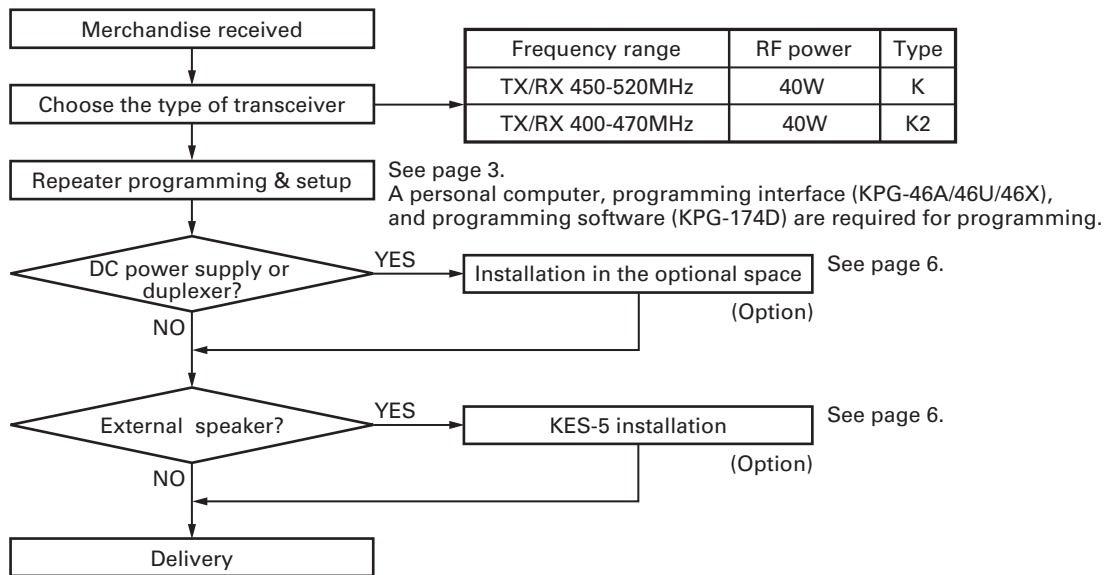

REALIGNMENT

1. Modes

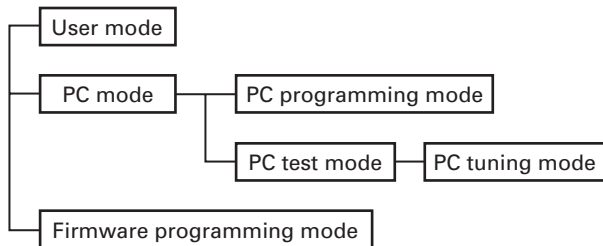

Mode	Function
User mode	Use this mode for normal operation.
PC mode	Use this mode to make various settings by means of the FPU through the RS-232C port.
PC programming mode	Use to read and write frequency data and other features to and from the repeater.
PC test mode	Use to check the repeater using the PC. This feature is included in the FPU.
Firmware programming mode	Use when changing the firmware program of the flash memory.

2. How to Enter Each Mode

Mode	Operation
User mode	Power on.
PC mode	Received commands from PC.
Firmware programming mode	[PF1] + Power on (one second)

3. PC Mode

3-1. Preface

The repeater is programmed by using a personal computer, programming interface (KPG-46A/46U/46X) and FPU (programming software).

The programming software can be used with a PC. Figure 1 shows the setup of a PC for programming.

3-2. Connection Procedure

1. Connect the repeater to the computer using the interface cable.

Note:

- You must install the KPG-46U/46X driver in the computer to use the USB programming interface cable (KPG-46U/46X).
2. When power is applied, the user mode is entered immediately. When the PC sends a command, the repeater enters the PC mode and displays "PC" on the 7-segment LED. When data is being transmitted to the PC from the repeater, the TX LED lights. The BUSY LED lights when data from the PC is being received by the repeater.

Note:

- The data stored in the personal computer must match the model type, when it is written into the flash memory.

REALIGNMENT

3-3. KPG-46A Description

(PC programming interface cable: Option)

The KPG-46A is required to interface the transceiver to the computer. It has a circuit in its D-sub connector (KPG-46A: 9-pin) case that converts the RS-232C logic level to the TTL level.

The KPG-46A connects the 8-pin microphone connector of the transceiver to the RS-232C serial port of the computer.

3-4. KPG-46U/46X description

(USB programming interface cable: Option)

The KPG-46U is a cable which connects to a USB port on a computer.

When using the KPG-46U, install the supplied CD (with driver software) in the computer. The KPG-46X driver runs under Windows XP, Vista, 7, 8 or 8.1.

The latest version of the USB driver is available for download from the following URL:

<http://www.kenwood.com/usb-com/>

(This URL may change without notice.)

3-5. Programming Software KPG-174D (Ver. 2.10 or later) Description

The FPU is the programming software for the transceiver supplied on a CD. This software runs under Windows XP, Vista, 7, 8 or 8.1 on a PC.

The data can be input to or read from the transceiver and edited on the screen. The programmed or edited data can be printed out. It is also possible to tune the transceiver.

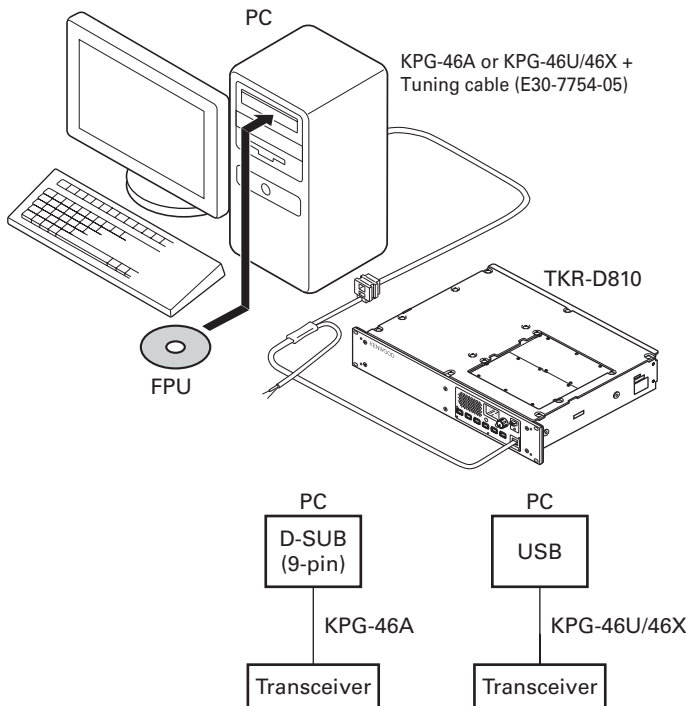

Fig. 1

4. Firmware Programming Mode

4-1. Preface

The repeater uses flash memory to allow it to be easily upgraded when new features are released in the future.

4-2. Connection Procedure

Connect the repeater to the personal computer using the interface cable (KPG-46A/46U/46X) (Connection is the same as in the PC Mode.)

Note:

You can only program firmware from the 8-pin microphone connector on the front panel. Using the 25-pin logic interface on the rear panel will not work.

4-3. Programming

1. Start up the firmware programming software (Fpro.exe (ver. 6.20 or later)). The Fpro.exe exists in the KPG-174D installed folder.
2. Set the communications speed (normally, 115200 bps) and communications port in the configuration item.
3. Set the firmware to be updated by File name item.
4. Turn the repeater power ON with the [PF1] key held down. Then, "PG." is displayed.
5. Check the connection between the repeater and the personal computer, and make sure that the repeater is in the Program mode.
6. Press write button in the window. When the repeater starts to receive data.
7. If writing ends successfully, the TX LED on the repeater lights.
8. If you want to continue programming other repeaters, repeat steps 4 to 7.

Note:

This mode cannot be entered if the Firmware Programming mode is set to Disable in the Programming software.

4-4. Function

If you press the [PF6] key while "PG." is displayed, the display changes to "PG" to indicate that the write speed is low speed (38400 bps). If you press the [PF6] key again while "PG" is displayed, the display changes to "PG." to indicate that the write speed is mid speed (57600 bps). If you press the [PF6] key again while "PG." is displayed, the display changes to "PG." to indicate that the write speed is high speed (115200 bps).

Note:

Normally, write in the high-speed mode.

OPERATING FEATURES

1. Two 7-segment LED Displays

- Channel display (1~30): While operating normally in user mode.

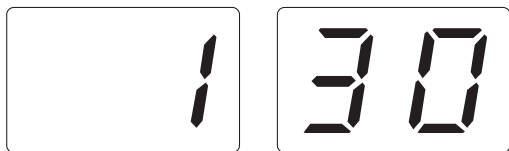

- "PC" is displayed while in PC mode.



- "PG" is displayed while in firmware programming mode.
2 decimal points displayed = 115,200 bps
1 decimal point displayed = 57,600 bps
No decimal = 38,400 bps

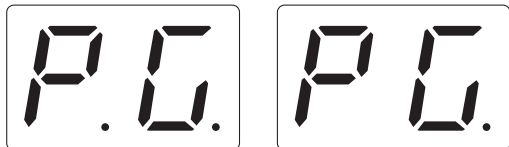

- "E1" is displayed when FPU data is not written.



- "E2" is displayed when the channel data is not written.



- "E3" is displayed when PLL is unlocked.
Receiver PLL unlocked = BUSY LED blinks.
Transmitter PLL unlocked = TX LED blinks.



- "E5" is ESN blank error.



- "E.6." is MCU internal RAM error.

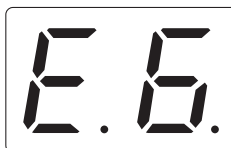

- "E6." is DSP RAM error.



- "E6" is MCU External RAM error.



- Intersite Call is set and "E7" is displayed when cannot be confirmed the connection of KTI-5.



- "E9" is displayed when there is a problem with Version combination of the repeater firmware and KTI-5 firmware.



INSTALLATION

1. External Speaker (KES-5)

The TKR-D810 has a built-in speaker (5W/8Ω), and the external speaker output from the TEST/SPKR connector (15-pin) on the rear of the radio is 4W/4Ω. Use external speaker KES-5.

1-1. Connection for the KES-5 with the TKR-D810

■ When taking the AF output from the TEST/SPKR connector (15-pin) on the rear of the radio

The following tools are required for changing the connector.

• Extracting tool

The following extracting tool is recommended:
Molex Inc. Order No.: 11-03-0002 (W05-0878-00)

1. Remove the connector with jumper from the external speaker connector on the rear panel of the radio. (Fig. 1-1)
- Note:** Save the jumper, which is required when the radio is used without the external speaker.
2. Remove the terminals with the jumper from the connector housing holes number 9 and 12 using the extracting tool.

Removing the jumper lead (Fig. 1-2)

- 1) Insert the extracting tool (11-03-0002) into the connector while pushing the jumper lead in the direction of (a).
 - 2) Push the extracting tool in to collapse the barbs of the crimp terminal.
 - 3) Pull out the lead while continuing to push the extracting tool in the direction (b).
3. Reinsert the terminal with the black and white stripe lead into hole number 12, and the terminal with the black lead into hole number 6. (Fig. 1-3)
 4. Attach the connector to the external speaker connector on the radio.

Note:

Relationship between the TEST/SPKR connector (15-pin) connection and speaker output:

- When pins 9 and 12 are shorted: The built-in speaker is used.
- When pins 9 and 12 are open and output is from pins 6 and 12: KES-5 is used.

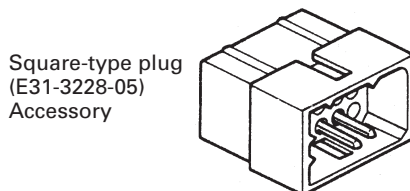

Fig. 1-1

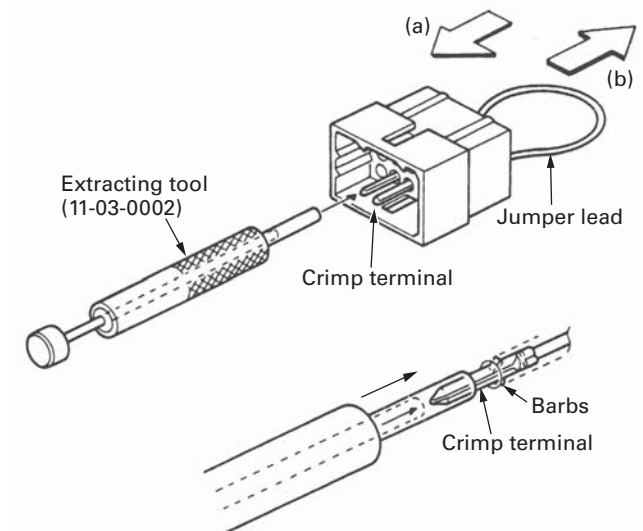

Fig. 1-2

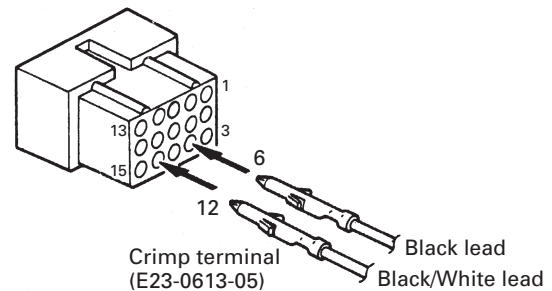

Fig. 1-3

2. Accessory Cabinet

You can install optional accessories, such as a DC power supply or duplexers, in the accessory cabinet.

1. Place the optional accessory in the cabinet as shown below.
2. If necessary, attach cushions (G13-1801-04 and/or G13-1802-04) to the top plate (J21-8559-04) in order to adjust the space between the cabinet and the top plate. Then, insert the 3 tabs of the plate into the slots in the side of the cabinet. High, middle, or low positions are available. To affix the plate, inset and tighten the 2 screws on the other side of the plate.

You can also flip the top plate upside-down to adjust the height of the cabinet space.

INSTALLATION

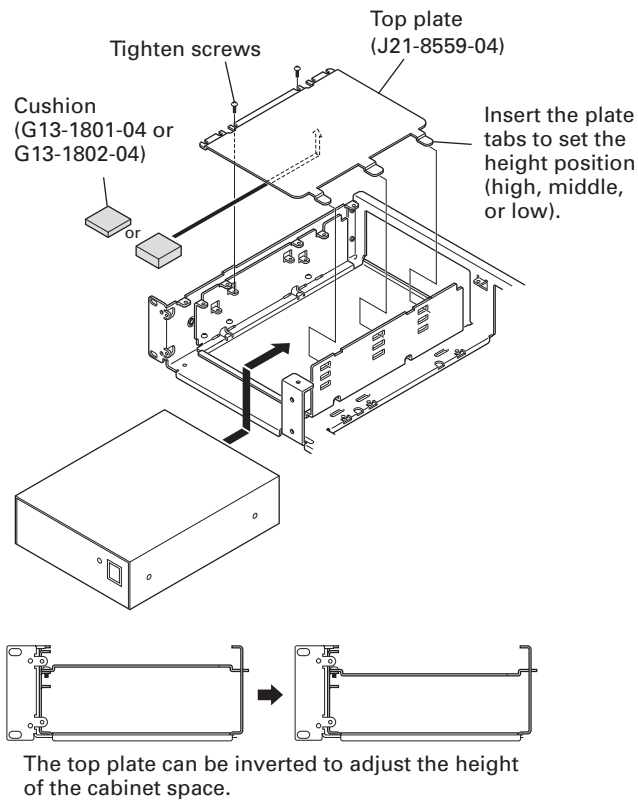

Fig. 2

3. Key Cover

To avoid accidentally pressing the keys, you can install the key cover.

1. Install and fix the key protector using the 5 supplied screws (N35-3006-43).

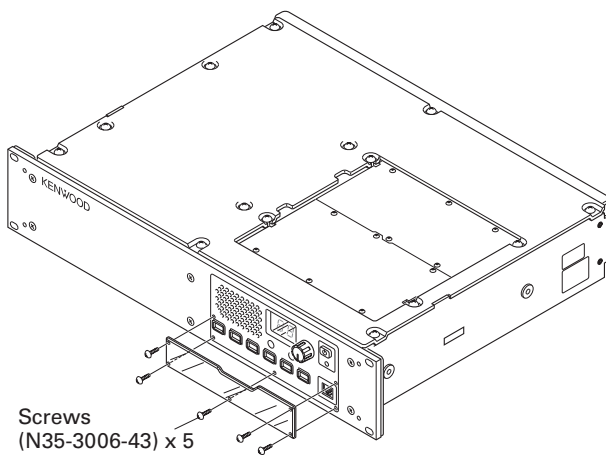

Fig. 3

4. Desktop Repeater

When you use the repeater on a desktop, attach the 4 spacers to the base of the repeater as shown in the figure. With these spacers attached, the front panel will not touch the desk surface.

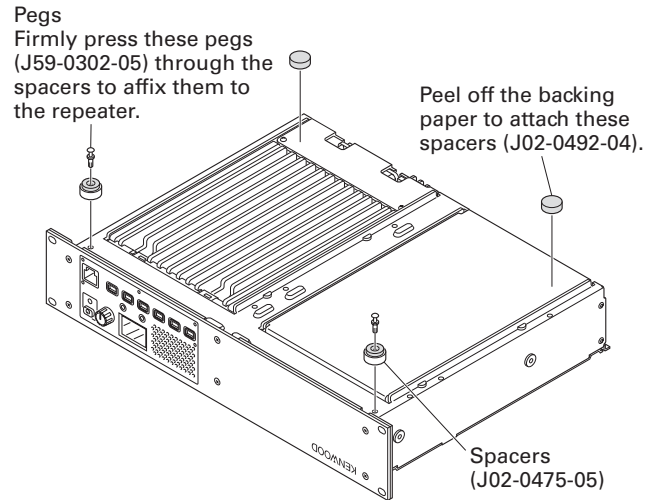

Fig. 4

5. Installing Name Plates

Punch out the name plate card. Then insert the plates onto the relative function keys.

You can reconfigure the name plates at any time.

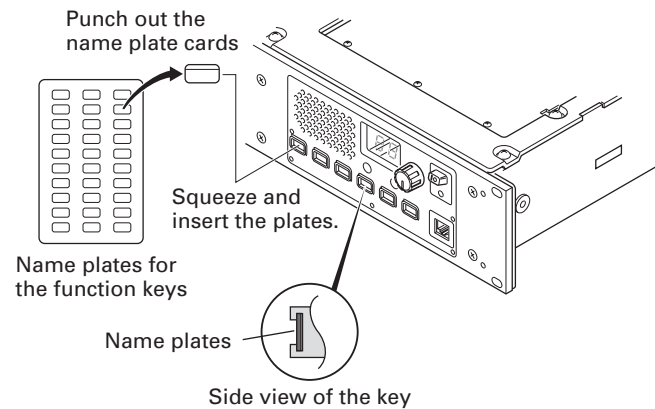

Fig. 5

MODIFICATION

1. DC Source Switch

To prevent the power supply from turning off due to misoperation of the DC source switch on the front panel or accidents (tampering) after installation, the main unit can be kept on regardless of the on/off setting of the DC source switch on the front panel.

Using solder, short the PSW land near the CN40 connector.

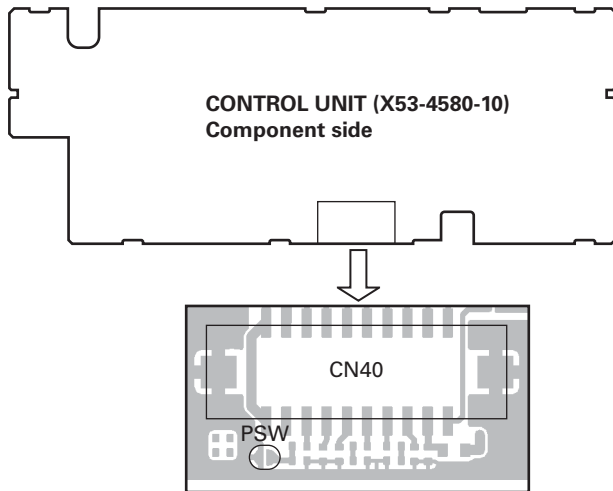

TKR-D810

DISASSEMBLY FOR REPAIR

1. How to Remove the Panel Assy (ABS)

Note: You can remove the panel assembly (ABS) without removing the top panel (A62-1148-03).

1. To remove the panel (TX-RX, ②), loosen the 6 screws (①).
2. To remove the panel assembly (Front, ④), loosen the 6 screws (③).
3. The panel assembly (ABS) is securely fastened by 4 tabs (⑤) on the top and bottom. You can remove the panel assembly by pulling to the front while you are pulling up the tabs.

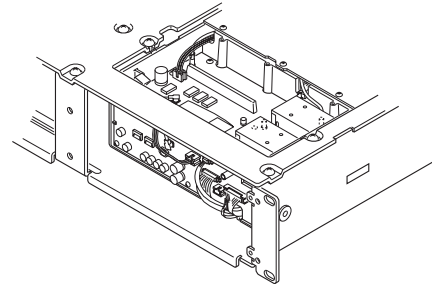
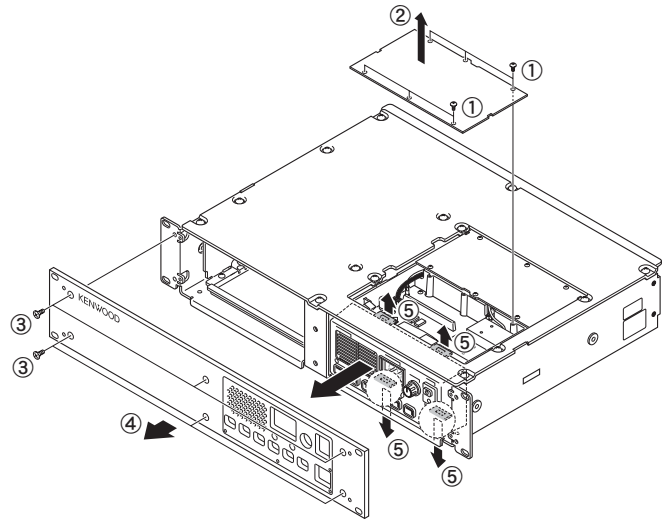

CIRCUIT DESCRIPTION

1. Outline

The TKR-D810 is a UHF repeater operating in the 450~520MHz (K) or 400~470MHz (K2) frequency range.

2. TX-RX unit

TX-RX unit (X57-897) consists of the following circuit.

- (1) Internal/external reference circuit
- (2) Transmitter reference 16.8MHz PLL circuit
- (3) Transmitter main PLL circuit
- (4) Modulation level adjustment circuit
- (5) Front-end circuit
- (6) 1st-Mixer circuit
- (7) IF circuit
- (8) Receiver PLL circuits
- (9) AVR circuits
- (10) Other circuits

2-1. Internal/External reference circuit

The internal reference circuit consists of X500, Q502, Q504 and D505. The output of 19.2MHz VCTCXO (X500) is fed to buffer amplifier Q502. The higher harmonic wave is attenuated by the LPF. This reference signal is fed to IF IC (IC304) as the 2nd Local signal through the Tripler.

The internal reference signal is amplified by Q504 to achieve the needed level for PLL ICs. That signal is divided by a Wilkinson divider. The divided signal is fed to the PLL IC for the receiver. Another signal is fed to the transmitter reference 16.8MHz PLL IC through PIN diode switch (D505).

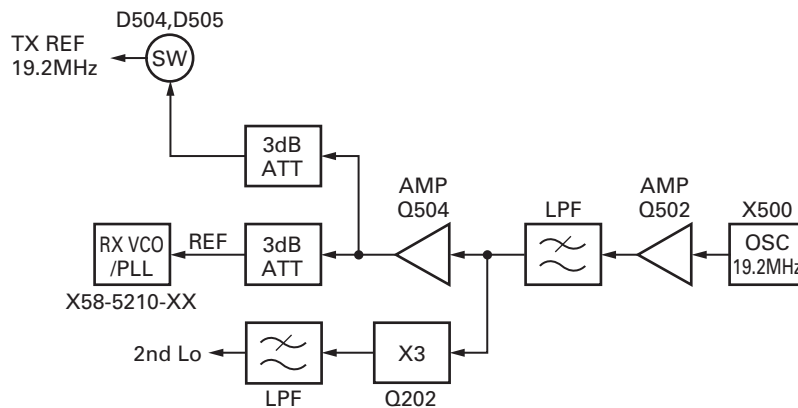

Fig. 1 Internal/external reference circuit

2-2. Transmitter reference 16.8MHz PLL circuit

The transmitter reference 16.8MHz PLL circuit produces the reference frequency signal for the Transmitter Main PLL circuit and modulates the low-frequency components.

The circuit consists of IC600, IC601, IC602, IC603, IC604, Q601, Q602, Q603, and X600.

The VCXO (X600) signal enters the buffer amplifier Q603 and is amplified by Q602. The higher harmonic wave is attenuated by the LPF and returns to IC602. Its phase is compared with that of the reference frequency 5kHz.

The phase difference signal produced by the comparing phase is converted to a DC voltage by a lag-lead type loop filter. This DC voltage is input to the IC604 invert amplifier and is synthesized with the modulating signal. This DC voltage is input to the X600 control voltage terminal for controlling the VCXO oscillating frequency 16.8MHz.

The 16.8MHz oscillating signal is fed to the Q603 buffer amplifier. The output signal of the buffer amplifier is used as the reference frequency signal of the transmitter main PLL circuit.

CIRCUIT DESCRIPTION

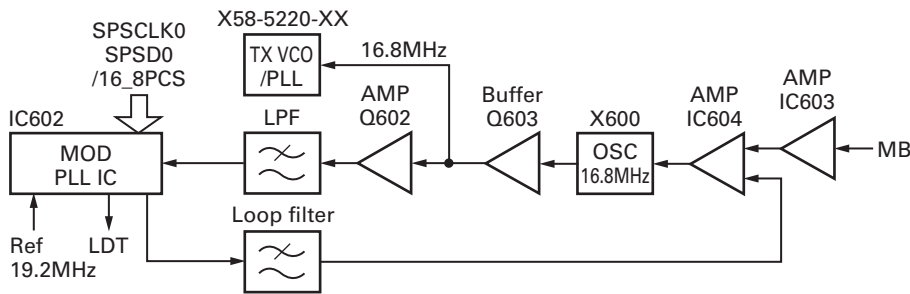

Fig. 2 Transmitter reference 16.8MHz PLL circuit

2-3. Transmitter Main PLL circuit (SUB unit)

■ VCO

The TX VCO circuit consists of two VCOs (VCO A X58-522: Q352, VCO B X58-522: Q353). Those VCOs generate a transmit carrier. VCO A Q352 produces a transmitter frequency from 450.000 to 484.995MHz (K) or 400.000 to 434.995MHz (K2). VCO B Q353 produces a transmitter frequency from 485.000 to 520.000MHz (K) or 435.000 to 470.000MHz (K2).

Those VCO oscillation frequencies are determined by two systems of voltage control terminals: "CV" and "TXASSIST".

The voltage control terminals, "CV" and "TXASSIST," are controlled by the PLL IC (X58-522: IC300) and MCU (X53-458: IC20) and the output frequency changes continuously according to the applied voltage. For the modulation input terminal, "MO," the output frequency changes according to the applied voltage.

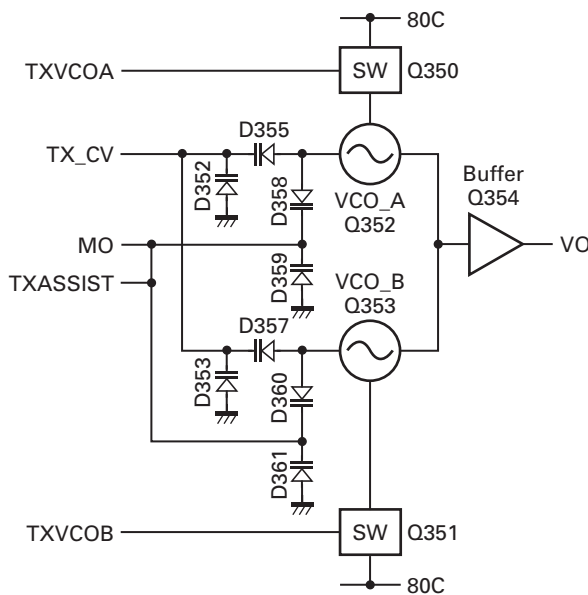

Fig. 3 Transmitter VCO circuit

■ PLL IC (X58-522: IC300)

The PLL IC compares the differences in phases of the VCO oscillation frequency and the transmitter PLL reference

signal (16.8MHz), returns the difference to the VCO CV terminal and realizes the "Phase Locked Loop" for the return control. This allows the VCO oscillation frequency to accurately match (lock) the desired frequency.

When the frequency is controlled by the PLL, the frequency convergence time increases as the frequency difference increases when the set frequency is changed. To supplement this, the MCU is used before control by the PLL IC to bring the VCO oscillation frequency close to the desired frequency. As a result, the VCO CV voltage does not change and is always stable at approx. 3.0V.

The desired frequency is set for the PLL IC by the MCU (X53-458: IC20) through the 3-line "SPSD0", "SPSCLK0", "/TXPCS" serial bus. Whether the PLL IC is locked or not is monitored by the MCU through the "LDT" signal line. If the VCO is not the desired frequency (unlock), the "LDT" logic is low.

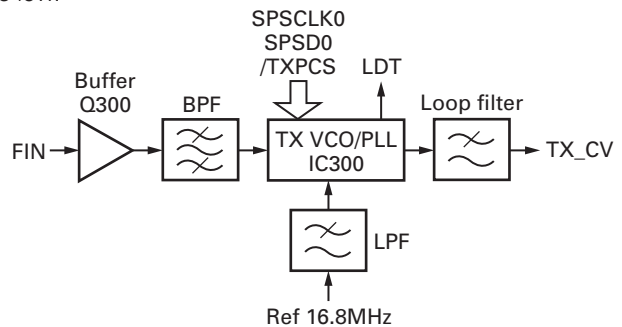

Fig. 4 Transmitter Main PLL IC circuit

2-4. Modulation level adjustment circuit

The Modulation level adjustment circuit adjusts the modulation waveform balance. This circuit consists of IC804, IC603, IC604, IC605 and IC606.

The modulating signal comes from the Control unit (X53-458) through the interface connector (CN800 Pin 14). The modulating signal is produced by the modulation low-pitched tone to the transmitter modulation 16.8MHz PLL circuit and adds the high-pitched modulation to the transmitter main PLL.

IC804 is an electronic volume control IC. It has 8 electronic volume control circuits. The modulation level adjustment circuit uses 2 electronic volume control circuits in IC804. The 1st electronic volume control circuit adjusts the

CIRCUIT DESCRIPTION

modulating signal and is fed to IC603 and the 2nd electronic volume control circuit. The 2nd electronic volume control circuit adjusts the modulating signal and is fed to IC606.

IC603 is an inverting amplifier for inverting the amplification of the modulating signal. The output of IC603 and the charge pump output of IC602 (Transmitter modulation 16.8MHz PLL IC) are synthesized by IC604 and is fed to VCXO (X600).

IC606 is a non-inverting amplifier. The output of the 2nd electronic volume control circuit is amplified by IC606 and is fed to the transmitter main PLL circuit.

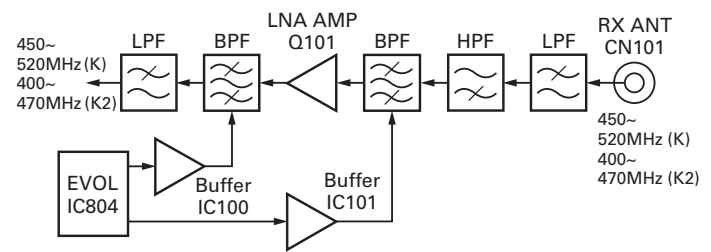

Fig. 6 Front-end circuit

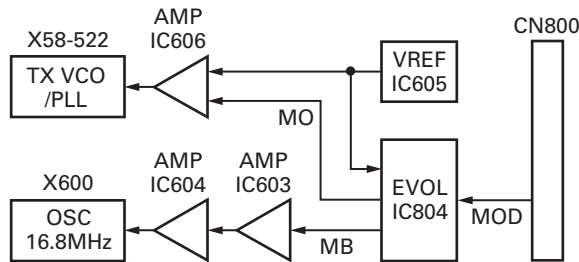

Fig. 5 Modulation level adjustment circuit

2-5. Front-end circuit

The front-end circuit consists of former LPF, former BPF (D105, D106, D107 and D108), RF Low Noise Amplifier (Q101), latter BPF (D100, D101, D103 and D104), and latter LPF. The BPF covers frequency ranges 450~520MHz (K) or 400~470MHz (K2).

The former LPF, former BPF, latter BPF, and latter LPF attenuate the unwanted signals and send only the necessary signal to the first mixer.

2-6. 1st-Mixer circuit

The filtered signal from the front-end circuit is heterodyned with the first local oscillator signal from the PLL frequency synthesizer circuit at the first mixer (IC300) to become a 58.05MHz first intermediate frequency (IF) signal.

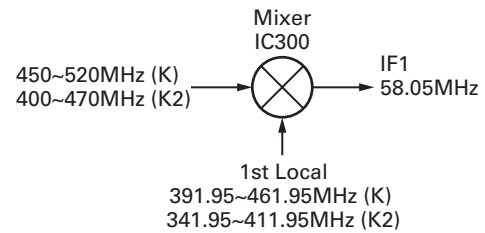

Fig. 7 1st-Mixer circuit

2-7. IF circuit

The first IF signal is amplified by the IF Post Amp (Q301) and passed through a four-pole monolithic crystal filter (XF300) to reject adjacent channel signal. The filtered first IF signal is amplified by the IF AGC amplifier (Q300) and then applied to the IF system IC (IC403). The IF system IC

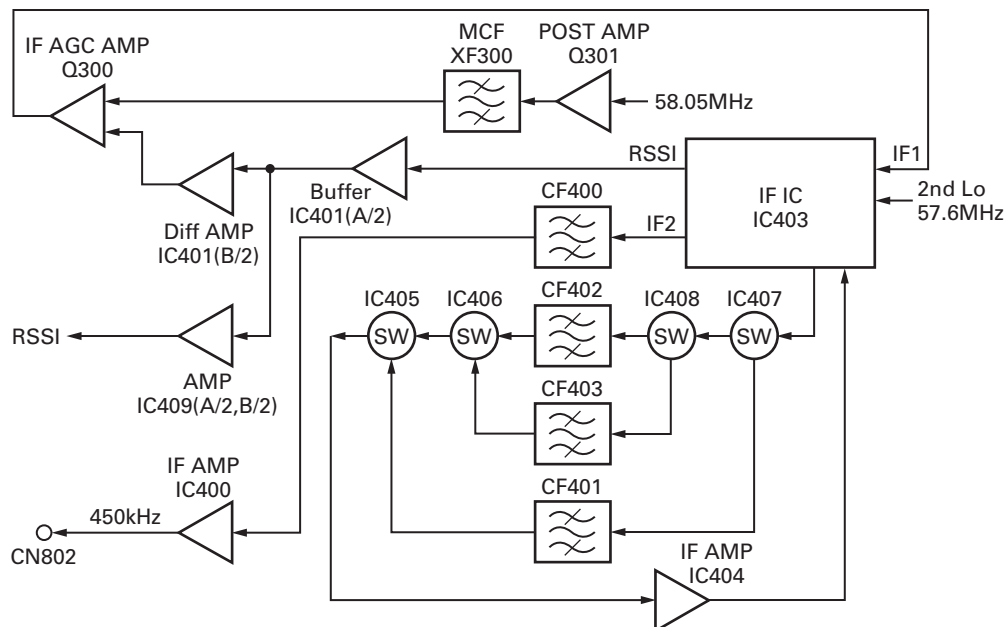

Fig. 8 IF circuit

CIRCUIT DESCRIPTION

provides a second mixer, AGC amplifier, and RSSI (Received Signal Strength Indicator).

The second mixer mixes the first IF signal with the 576 MHz of the second local oscillator output and produces the second IF signal of 450kHz.

The second IF signal is passed through the ceramic filter (CF401, CF402 and CF403) to reject the adjacent channel signals. The filtered second IF signal is amplified by the second IF amplifier (IC404) and AGC amplifier (IC403).

The signal from the AGC amplifier is input to the AD converter (X53-458: IC20) through the ceramic filter (CF400) and operational amplifier (IC400 and X53-458: IC20).

2-8. Receiver PLL circuit (SUB unit)

■ VCO

RX VCO circuit consists of two VCOs (VCO A X58-521: Q352, VCO B X58-521: Q353). Those VCOs generate a 1st local signal. For the VCO oscillation frequency, the 1st local signal is 391.95 to 461.95MHz (K) or 341.95 to 411.95MHz (K2). (VCO A: 391.95~426.95MHz (K) or 341.95~376.95MHz (K2), VCO B: 426.95~461.95MHz (K) or 376.95~411.95MHz (K2))

Those VCO oscillation frequency is determined by two systems of voltage control terminals "CV" and "RXASSIST".

The voltage control terminals, "CV" and "RXASSIST", are controlled by the PLL IC (X58-521: IC300) and the MCU (X53-458: IC20) and the output frequency changes continuously according to the applied voltage.

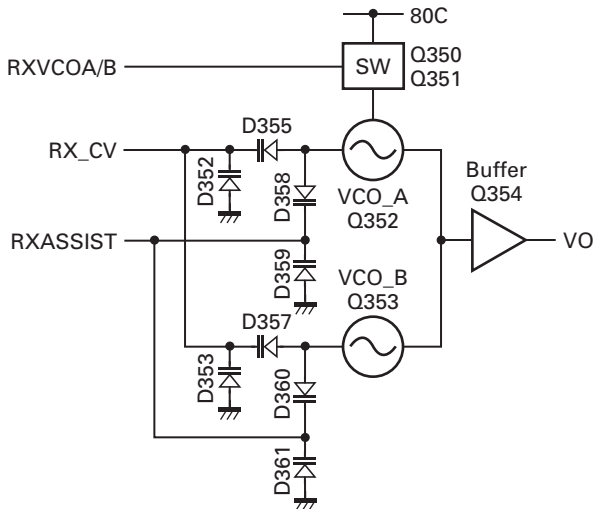

Fig. 9 Receiver VCO circuit

■ PLL IC (X58-521: IC300)

PLL IC compares the differences in phases of the VCO oscillation frequency and the VCTCXO reference frequency, returns the difference to the VCO CV terminal and realizes the "Phase Locked Loop" for the return control. This allows the VCO oscillation frequency to accurately match (lock) the desired frequency.

When the frequency is controlled by the PLL, the frequency convergence time increases as the frequency difference increases when the set frequency is changed. To supplement this, the MCU is used before control by the PLL IC to bring the VCO oscillation frequency close to the desired frequency. As a result, the VCO CV voltage does not change and is always stable at approx. 3.0V.

The desired frequency is set for the PLL IC by the MCU (X53-458: IC20) through the 3-line "SPSD0", "SPSCLK0", "/RXPCS_TR" serial bus. Whether the PLL IC is locked or not is monitored by the MCU through the "LDR" signal line. If the VCO is not the desired frequency (unlock), the "LDR" logic is low.

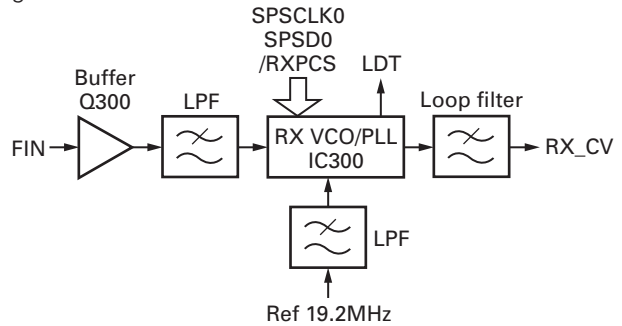

Fig. 10 Receiver PLL circuit

2-9. AVR circuit

The Power Source (+B) is provided through the Connector (CN701) from the Final unit (X45-402). +B is connected to the FET switch (Q702, Q703) and CN700. Q702 and Q703 are controlled by the "SBC" signal from the MCU which is in the Control unit (X53-458). If "SBC" logic is high, Q702 and Q703 turn on. The power source (SB) which is turned on by Q702 and Q703 is provided to the 8V AVR IC (IC702) and CN700. CN700 is connected to the Control unit (X53-458) to provide the +B power source and the SB power source.

IC702 supplies 8V to the VCO, 15V DC/DC converter IC (IC701), AVR IC (IC700) and FET switches (Q700, Q701). IC701 is a step-up switching regulator. IC701 regulates 8V to 15V and supplies the 15V power source to the "assist circuit" and "front-end BPF tuning circuit". The FET switches (Q700, Q701) are controlled by the I/O expander IC (IC805). When Q700 and Q701 turn on, the 8V power source is provided to the receiver section.

IC700 regulates 5V to 8V. The output of IC700 is provided to the FET switches (Q705, Q706) and AVR IC (IC703). The FET switches (Q705, Q706) are controlled by the I/O expander IC (IC805). When Q705 and Q706 turn on, the 5V power source is provided to the receiver section, IF section and IC704. IC704 regulates 5V to 3V. The 3V power source is provided to the Mixer IC (IC300). IC703 regulates 5V to 3.3V. The output of IC703 is provided to the IF section.

CIRCUIT DESCRIPTION

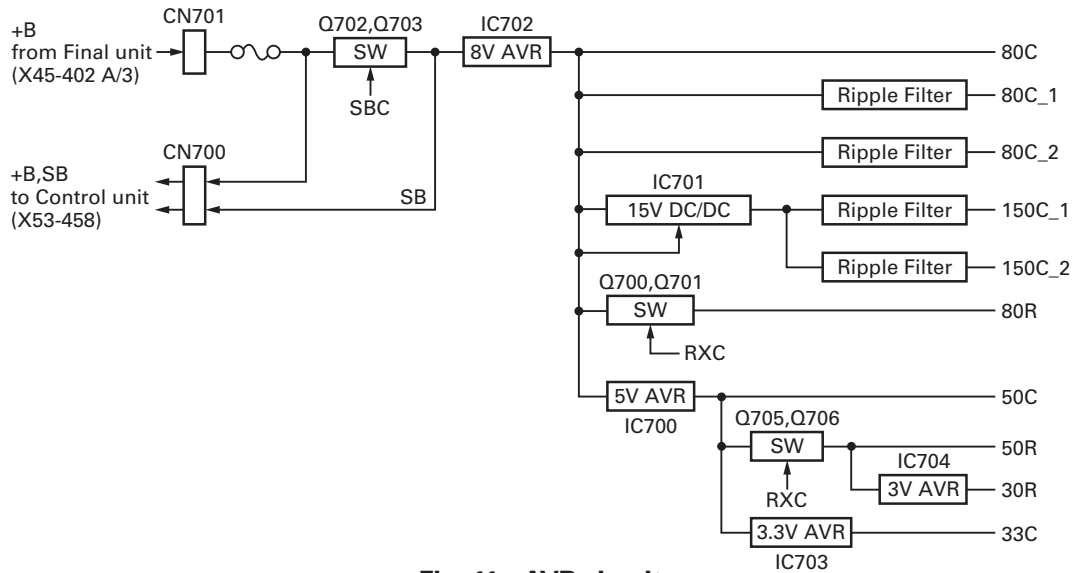

Fig. 11 AVR circuit

2-10. Other circuit

■ EEPROM

The EEPROM (IC802) has a data capacity of 2Kbit. It stores the tuning data in frequency adjustment.

■ Temperature sensor

The temperature sensor (IC800) monitors temperature around the VCTCXO (X500).

■ I/O expander

The I/O expander IC (IC805) controls the power sources, fan, analogue switches, and the transmit power control circuit. IC805 is controlled by the MCU which is in the Control unit (X53-458).

■ Electronic volume control IC

The Electronic volume control IC (IC804) adjusts the modulating signal, center frequency of the front-end BPF, and the power of the RF final amplifier. IC804 is controlled by the MCU which is in the Control unit.

3. Final unit

The RF final amplifier unit (X45-402) amplifies the transmitter power to a specified level.

This unit consists of the following circuits:

- (1) Driver and Final power amplifier circuit
- (2) CM coupler circuit
- (3) Filter circuit
- (4) APC circuit
- (5) High temperature detector circuit
- (6) FAN action control circuit
- (7) AVR circuit

3-1. Driver and Final power amplifier circuit

The transmit signal from the TX IN terminal CN1 of the Final unit (X45-402) is amplified by Q1, Q2 and Q3, and is passed to the final stage Q4. The signal amplified by the final stage Q4 passes through the CM coupler circuit and filter circuit, and is then fed to the antenna.

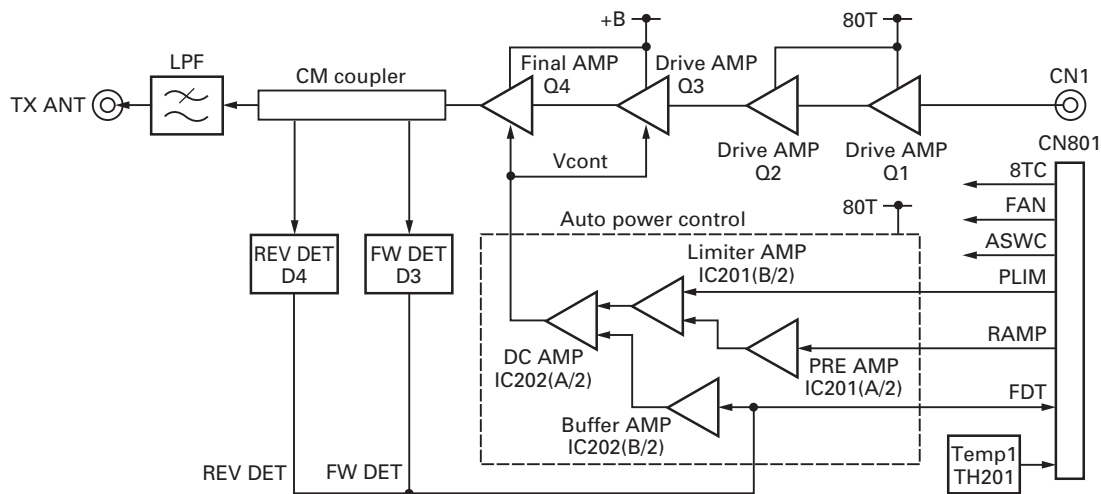

Fig. 12 Driver and Final power amplifier circuit

CIRCUIT DESCRIPTION

3-2. CM coupler circuit

The CM coupler circuit is a line for detecting forward wave and reflected wave. Forward wave is detected by D1, and is converted into DC voltage. If an abnormal antenna load is connected, reflected wave is detected by D3 and converted into DC voltage.

3-3. Filter circuit

This circuit removes harmonics from the transmitter output and sends filtered signals to the antenna.

3-4. APC circuit

The automatic transmission power control (APC) circuit stabilizes the transmitter output power at a pre-determined level. DC voltage from the CM coupler circuit is amplified by the DC amplifier IC202 (1/2). IC202 (2/2) compares the APC control voltage (RAMP) generated by the MCU (X53-458) and the DC amplifier IC201 (1/2, 2/2) with the output voltage from IC202 (1/2) to control the gate voltage for amplifier Q2, Q3 and final amplifier Q4.

3-5. High temperature detector circuit

To prevent thermal destruction of amplifier Q3 and final amplifier Q4, this circuit reduces the APC control voltage (RAMP) when the temperature of the amplifier Q3 and final amplifier Q4 rises. The MCU detects the temperature with the thermistor (TH201) and controls the APC voltage (RAMP).

3-6. FAN action control circuit

The FAN action control circuit consists of the FAN and switching transistor Q207. It is controlled by the MCU (X53-458). If the FAN action is set to "Temperature", the cooling fan is turned ON or OFF according to the temperature. If the FAN action is set to "Continuous", the cooling fan operates continuously, but Q207 stays ON.

3-7. AVR circuit

The power source (+B) is provided through connector CN201 to the Final unit (X45-402 A/3). +B is connected to CN203 to supply the 13.6V power source for the TX-RX unit (X57-897). +B is a power source for the "final amplifier", "drive amplifier" and fan. IC203 regulates the +B voltage to 8V. This 8V power source is connected to the FET switches Q203, Q204, Q205, and Q206. Q204 and Q206 are controlled by the "8TC" signal from the I/O expander IC which is in the TX-RX unit (X57-897). If "8TC" logic is high, Q204 and Q206 turn on and supply the 8V power source to the APC circuit and pre drive amplifiers. Q203 and Q205 are controlled by the "ASWC" signal from the I/O expander IC which is in the TX-RX unit (X57-897). If "ASWC" logic is high, Q203 and Q205 turn on and supply the 8V power source to the antenna switch circuit.

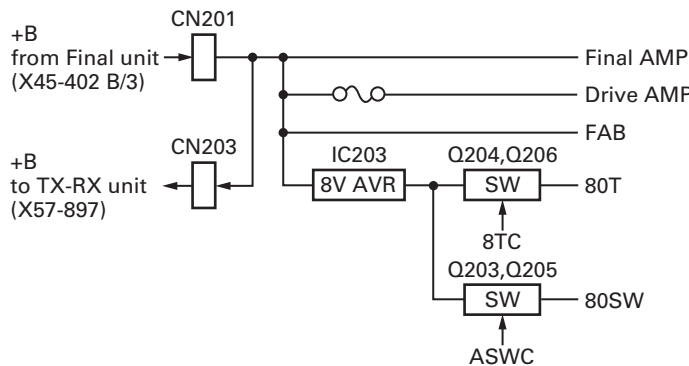

Fig. 13 AVR circuit

4. Control unit

The Control unit (X53-458) consists of the following circuits:

- (1) MCU circuit
- (2) Memory circuit
- (3) DSP circuit
- (4) Squelch circuit
- (5) Power supply circuit
- (6) Power Supply Voltage Monitoring Circuit
- (7) 18.432MHz clock circuit
- (8) Audio circuit
- (9) Other circuit

4-1. MCU circuit

The MCU (IC20) is a 32bit RISC processor, equipped with a peripheral function and ADC/DAC.

This MCU operates at a 18.432MHz clock and 3.3V/1.5V DC.

It controls the flash memory, SRAM, DSP, receive circuit, transmitter circuit, and control circuit.

CIRCUIT DESCRIPTION

4-2. Memory circuit

The Memory circuit consists of the MCU (IC20), the SRAM (IC9), and the flash memory (IC3).

The flash memory has a capacity of 32Mbit that contains the transceiver control program for the MCU and stores the data. It also stores the data for transceiver channels and operating parameters that are written by the FPU. This program can be easily written from external devices.

The SRAM has a capacity of 1Mbit that contains work area and data area.

■ Flash memory

Note: The flash memory stores the data that is written by the FPU, tuning data (Deviation, Squelch, etc.), and firmware program.

■ SRAM (static memory)

Note: The SRAM has a temporary data area and work area. When the power supply is off, it is backed up by an internal secondary lithium battery. Therefore, the saved data is not lost.

4-3. DSP circuit

The DSP circuit consists of a DSP (IC6) and processes the base band signal. The DSP operates on an external clock of 18.432MHz (the same as IC20). The I/O section operates at 3.3V and the core section operates at 1.6V. The DSP carries out the following processes:

■ Digital processing

- 4Level FSK and Baseband filter processing
- Vocoder processing between audio codec and modulation/demodulation
- CAI processing, such as error correction encoding/decoding and interleaving
- AFC loop control
- Frame synchronization and Time tracking
- Data scrambling

■ Analog FM processing

- Pre-emphasis/De-emphasis
- QT/DQT encoding/decoding
- DTMF encoding/decoding
- Compressor/Expander processing
- Voice scrambler processing

■ Audio or Modulation function

- Transmit/Receive audio filtering processing
- Microphone amplifier AGC processing
- Audio soft mute processing
- Modulation level processing
- Squelch Filtering

■ Other function

- Courtesy tone
- Repeater operating
- Analog/Digital Mixed mode

4-4. Squelch circuit

The Squelch circuit amplifies the demodulated noise signal from IC6 after filtering through the BPF circuit. The processed digital noise signal is applied to CODEC IC14, and is converted from digital to analog. The amplified signal is then converted to a DC signal by the detection circuit. The converted signal is fed back to IC20.

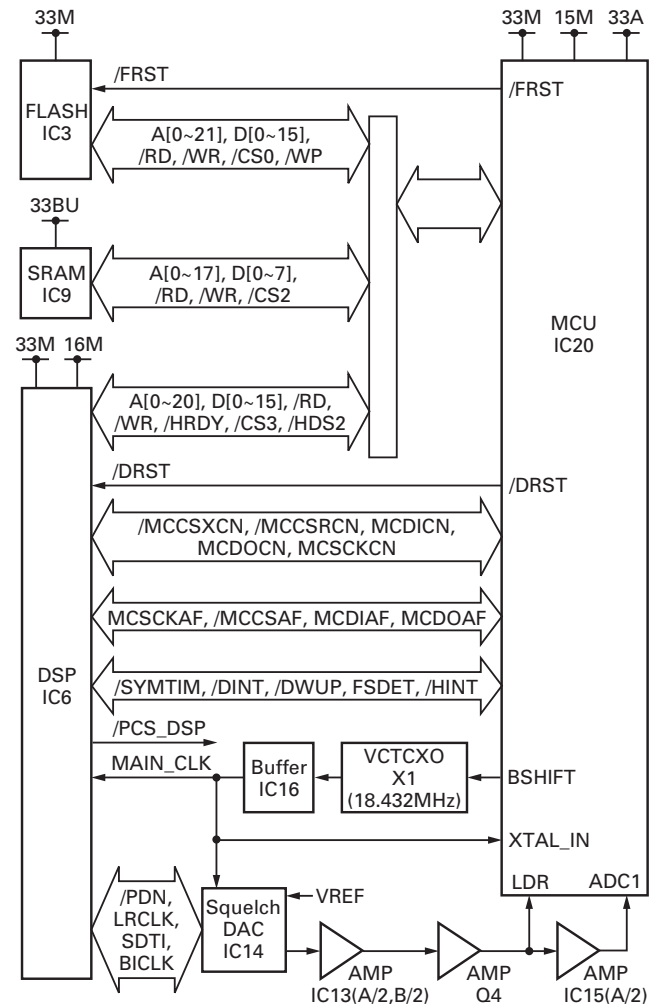

Fig. 14 Control circuit

4-5. Power supply circuit

The X53-458 circuit consists of IC301, IC302, IC303, IC304, IC305 and IC306.

IC301 is a DC/DC converter that converts 13.6V to 6.0V. This 13.6V voltage is supplied from TX-RX unit (X57-897).

IC302 is connected to IC301 and regulates the voltage to 5.0V. IC303, IC304, IC305 and IC306 are connected to IC301. IC303 and IC306 are 3.3V voltage regulators. IC304 is a 1.5V regulator IC, and IC305 is a 1.6V regulator IC.

CN302 is the connector for the lithium battery. The lithium battery is used to back up the SRAM and RTC data when no external DC power source is available.

CIRCUIT DESCRIPTION

4-6. Power supply voltage monitoring circuit

The X53-458 circuit consists of IC307, IC308, D303 and Q301.

IC308 is a voltage detect IC and is used to generate the "/RST" signal for the MCU (IC20).

This "/RST" signal is connected to the hardware reset pin of MCU (IC20).

IC307 is a voltage detect IC and is used to generate the "/BINT" signal for the MCU (IC20).

This "/BINT" signal is connected to the hardware interrupt pin of MCU (IC20). The software of the MCU (IC20) runs to the sleep-mode to use the "/BINT" signal.

D303 and Q301 are used to generate the "OVRB" signal for the MCU (IC20). The software of the MCU (IC20) runs to the sleep-mode to use the "OVRB" signal.

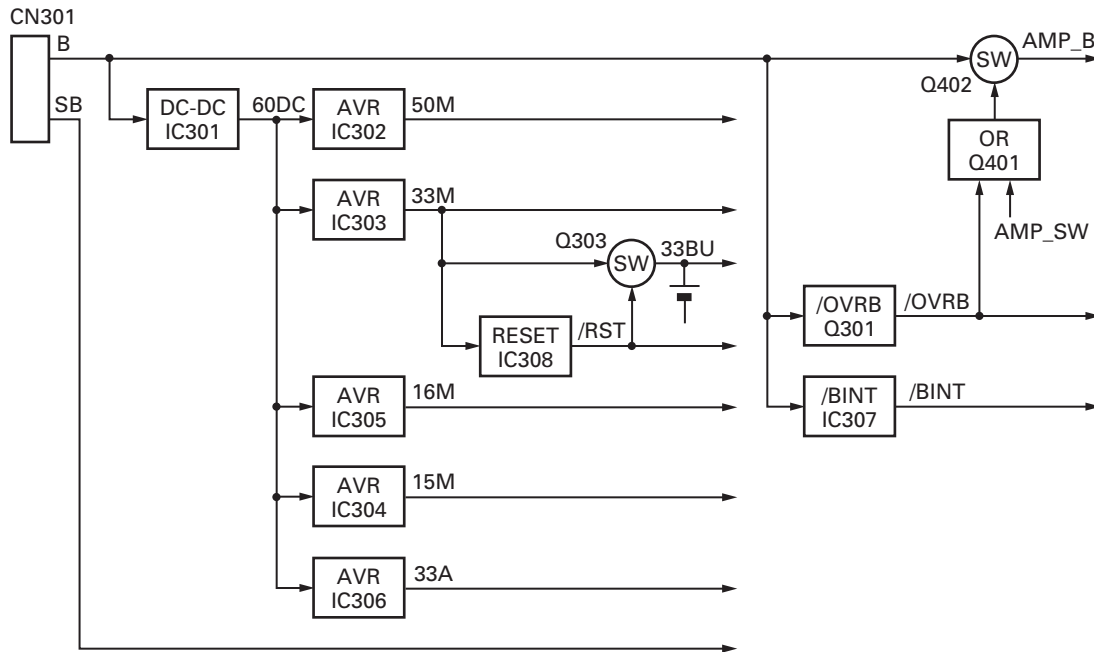

Fig. 15 Power supply circuit

4-7. 18.432MHz clock circuit

The 18.432MHz clock is provided to the MCU (IC20), DSP (IC6), and DAC (IC14) of the Squelch circuit.

4-8. Audio circuit

■ Audio amplifier circuit

The audio amplifier circuit is located in the control section of the Control unit (X53-458). The 4W output audio power is available from the pin 15 TEST/SPKR connector "SPO"; "SPG" on the rear panel to the external speaker in the case of a power supply voltage of 13.6V and a 4Ω load.

■ Microphone circuit

The signal from the microphone is passed through the AGC circuit located in the Display unit (X54-406 A/2) so that it may not saturate. This circuit consists of IC501, D501, D502, Q501, and Q502. The AGC controls the amplifier gains using the detected audio signal depending on the positive and negative peaks of the signal amplitude. The audio signal goes to the control section of the Control unit (X53-458) from the Display unit (X54-406 A/2).

■ Modulation circuit (Analog/Digital signal processing)

In the case of the Analog Signal Processing mode, the transmitting audio signal is amplified by IC405 (C/4), input to the MICADCO terminal of the MCU (IC20), and audio processed by DSP (IC6). The processed audio signal from the MODDAC terminal of IC20 is passed through an anti-aliasing filter at IC404 (A/2), and is then amplified to a sufficient level by IC404 (B/2), and amplified by the summing (TD) amplifier. The Digital Signal Processing mode is the same as the Analog Signal Processing mode.

4-9. Other circuit

■ Real-time clock

The clock function is based on a real-time clock IC (IC17). When the power supply is off, it is backed up by an internal secondary lithium battery.

CIRCUIT DESCRIPTION

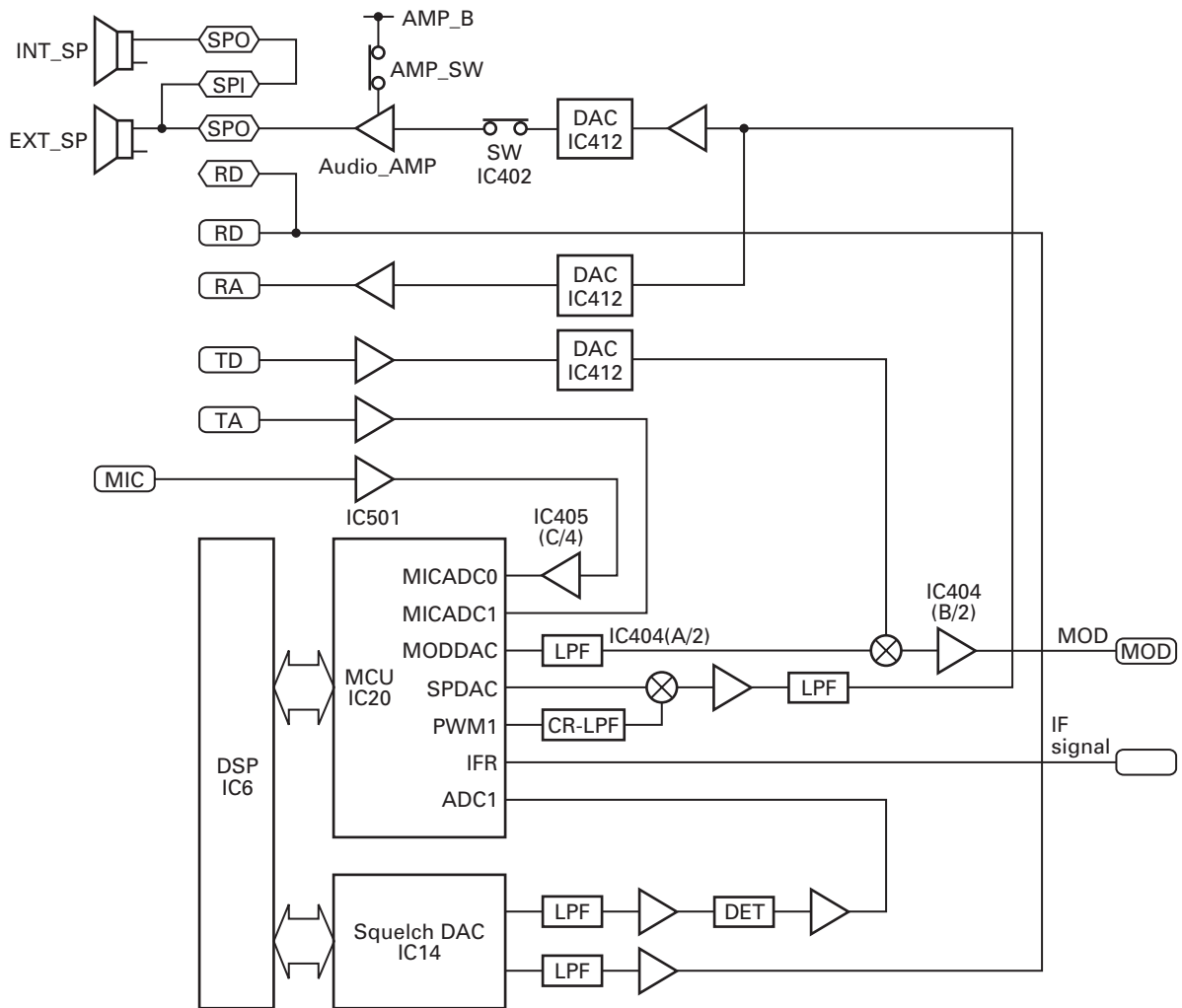

Fig. 16 Modulation circuit (Analog/Digital signal processing)

5. Display unit

The Display unit (X54-4060-20) is different from X54-3580-20 which is used in the TKR-750/850/751/851.

The Display unit (X54-4060-20) consists of the following circuits:

- (1) LED circuit
- (2) Key switch circuit
- (3) Power supply voltage detector

5-1. LED circuit

The display circuit consists of various types of LEDs: 7-segment type D506 and D507 (red), D503 (red: transmission), D504 (green: busy), D505 (green: power on).

IC502 to IC505 are shift registers that convert MCU serial data to parallel data and turn on the LEDs.

5-2. Key switch circuit

There are PF key 1 to PF key 6 on the Display unit. Using these key switches, mode settings are available.

The logic signals pushing these key switches are entered directly into the MCU (IC20).

5-3. Power supply voltage detector

The Display unit has a power supply voltage detector circuit.

The power supply voltage (SB) is divided through two resistors (R545 and R546).

The divided voltage is input to the MCU via the IC508.

COMPONENTS DESCRIPTION

FINAL UNIT (X45-4020-XX)

Ref. No.	Part Name	Description
IC201,202	IC	DC amplifier
IC203	IC	Voltage regulator
Q1	Transistor	RF amplifier
Q2	FET	RF amplifier
Q3	FET	TX drive amplifier
Q4	FET	Final amplifier
Q203~206	FET	DC switch
Q207	Transistor	DC switch
D1~3	Diode	RF detector
D4~7	Diode	RF switch
D8	Surge absorber	Surge protection
D201	Zener diode	Voltage reference
D202	Surge absorber	Surge protector
D203	Diode	Surge protector
D301	Diode	Protect of reverse connection

CONTROL UNIT (X53-4580-10)

Ref. No.	Part Name	Description
IC3	IC	Flash memory
IC4,5	IC	RS-485 transceiver
IC6	IC	DSP
IC7,8	IC	Buffer
IC9	IC	SRAM
IC10,11	IC	Buffer
IC12	IC	AND gate
IC13	IC	AF amplifier
IC14	IC	CODEC
IC15	IC	AF amplifier
IC16	IC	Buffer amplifier
IC17	IC	RTC IC
IC18,19	IC	Buffer
IC20	IC	MCU
IC21	IC	RS-232C driver/receiver
IC22	IC	I/O expander
IC23	IC	NAND gate
IC24	IC	AND gate
IC25	IC	OR gate
IC26	IC	AND gate
IC27,28	IC	AF amplifier
IC301	IC	DC/DC converter
IC302	IC	Voltage regulator
IC303~306	IC	Voltage regulator
IC307	IC	Voltage regulator
IC308	IC	Voltage regulator
IC401	IC	NAND gate

Ref. No.	Part Name	Description
IC402	IC	Analog switch
IC403	IC	AF power amplifier
IC404~406	IC	OP AMP
IC407	IC	Analog switch
IC411	IC	OP AMP
IC412	IC	DC/AC converter
Q4	Transistor	DC switch
Q5	FET	DC switch
Q6~10	Transistor	Buffer amplifier
Q301	Transistor	DC switch
Q302	FET	DC switch
Q303	Transistor	Power switch
Q401	Transistor	Power switch
Q402	FET	Power switch
Q403	Transistor	Power switch
Q404,405	Transistor	AF mute switch
D1,2	Diode	Detector
D3~12	Diode	Surge protector
D13	Zener diode	Surge protector
D14~16	Diode	Surge protector
D18	Diode	Surge protector
D20	Diode	Surge protector
D22,23	Diode	Surge protector
D24	Zener diode	Surge protector
D26	Diode	Surge protector
D28,29	Diode	Surge protector
D30	Zener diode	Surge protector
D31	Diode	Surge protector
D32	Zener diode	Surge protector
D35	Diode	Surge protector
D36	Zener diode	Surge protector
D37	Varistor	Current protector
D301,302	Diode	Surge protector
D303	Zener diode	Voltage reference
D304,305	Diode	Surge protector
D401	Diode	Diode switch

DISPLAY UNIT (X54-4060-20)

Ref. No.	Part Name	Description
IC501	IC	MIC amplifier
IC502~505	IC	Shift register
IC506,507	IC	Voltage regulator
IC508	IC	Analog switch
Q501,502	Transistor	Level controller
Q503,504	FET	DC switch
Q506	Transistor	DC switch

COMPONENTS DESCRIPTION

Ref. No.	Part Name	Description
Q507	FET	DC switch
Q508~511	Transistor	DC switch
Q512~514	FET	DC switch
Q516~519	FET	DC switch
Q521~525	FET	DC switch
D501,502	Diode	AF detector
D503~507	LED	LED
D508~514	Diode	Surge absorption
D601,602	Diode	Surge absorption
D603	Varistor	Current protector

TX-RX UNIT (X57-897K-XX)

Ref. No.	Part Name	Description
IC100,101	IC	OP AMP
IC200,201	IC	OP AMP
IC203	IC	Buffer
IC300	IC	Mixer
IC400	IC	IF amplifier
IC401	IC	Buffer amplifier
IC402	IC	OP AMP
IC403	IC	IF system
IC404	IC	IF amplifier
IC405~408	IC	Analog switch
IC409	IC	Buffer amplifier
IC500	IC	Buffer amplifier
IC501	IC	OP AMP
IC600,601	IC	Buffer
IC602	IC	16.8MHz PLL
IC603~607	IC	OP AMP
IC608	IC	AF amplifier
IC700~702	IC	Voltage regulator
IC703,704	IC	Voltage regulator
IC800	IC	Temperature sensor
IC801	IC	OP AMP
IC802	IC	EEPROM
IC803	IC	Buffer amplifier
IC804	IC	Digital potentiometer
IC805	IC	I/O expander
IC806	IC	Analog switch
Q100	Transistor	DC switch
Q101	Transistor	RF amplifier
Q200,201	Transistor	DC switch
Q202,203	Transistor	RF amplifier
Q300	FET	RF amplifier
Q301	Transistor	RF amplifier
Q500	FET	DC switch

Ref. No.	Part Name	Description
Q501	Transistor	RF amplifier
Q502,503	FET	RF amplifier
Q504	Transistor	RF amplifier
Q505~507	FET	DC switch
Q600	FET	DC switch
Q601	Transistor	DC switch
Q602,603	Transistor	RF amplifier
Q604,605	Transistor	DC switch
Q606	Transistor	RF amplifier
Q607	FET	DC switch
Q700~702	FET	DC switch
Q703	Transistor	DC switch
Q704~706	FET	DC switch
Q800	FET	DC switch
D100,101	Varicap	Frequency control
D103~108	Varicap	Frequency control
D200	Diode	DC switch
D500,501	Zener diode	Limiter
D503	Diode	Detector
D504,505	Diode	RF switch
D600	Diode	DC switch
D601	Diode	RF switch
D801	Diode	DC switch

RX VCO/PLL UNIT (X58-5210-XX)

Ref. No.	Part Name	Description
IC300	IC	PLL
Q300	Transistor	Buffer amplifier
Q350,351	FET	DC switch
Q352,353	FET	VCO OSC
Q354	Transistor	Buffer amplifier
D352,353	Varicap	Frequency control
D355	Varicap	Frequency control
D357~361	Varicap	Frequency control

TX VCO/PLL UNIT (X58-5220-XX)

Ref. No.	Part Name	Description
IC300	IC	PLL
Q300	Transistor	Buffer amplifier
Q350,351	FET	DC switch
Q352,353	FET	VCO OSC
Q354	Transistor	Buffer amplifier
D352,353	Varicap	Frequency control
D355	Varicap	Frequency control
D357~361	Varicap	Frequency control

PARTS LIST

CAPACITORS

$\frac{C}{1} \frac{C}{2} \frac{T}{3} \frac{H}{4} \frac{2}{5} \frac{2}{6} \frac{0}{6} \frac{J}{6}$

- 1 = Type ... ceramic, electrolytic, etc.
- 2 = Shape ... round, square, etc.
- 3 = Temp. coefficient
- 4 = Voltage rating
- 5 = Value
- 6 = Tolerance

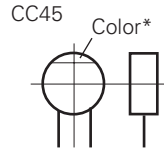

• Capacitor value

- 010 = 1pF
- 100 = 10pF
- 101 = 100pF
- 102 = 1000pF = 0.001μF
- 103 = 0.01μF

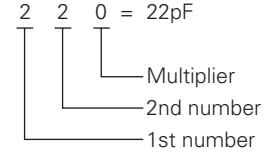

• Temperature coefficient

1st Word	C	L	P	R	S	T	U
Color*	Black	Red	Orange	Yellow	Green	Blue	Violet
ppm/°C	0	-80	-150	-220	-330	-470	-750

2nd Word	G	H	J	K	L
ppm/°C	±30	±60	±120	±250	±500

Example : CC45TH = -470±60ppm/°C

• Tolerance (More than 10pF)

Code	C	D	G	J	K	M	X	Z	P	No code
(%)	±0.25	±0.5	±2	±5	±10	±20	+40 -20	+80 -20	+100 -0	More than 10μF : -10~+50 Less than 4.7μF : -10~+75

(Less than 10pF)

Code	B	C	D	F	G
(pF)	±0.1	±0.25	±0.5	±1	±2

• Voltage rating

2nd word \ 1st word	A	B	C	D	E	F	G	H	J	K	V
0	1.0	1.25	1.6	2.0	2.5	3.15	4.0	5.0	6.3	8.0	-
1	10	12.5	16	20	25	31.5	40	50	63	80	35
2	100	125	160	200	250	315	400	500	630	800	-
3	1000	1250	1600	2000	2500	2150	4000	5000	6300	8000	-

• Chip capacitors

- (EX) $\frac{C}{1} \frac{C}{2} \frac{7}{3} \frac{F}{3} \frac{S}{4} \frac{L}{4} \frac{1}{5} \frac{H}{5} \frac{0}{6} \frac{0}{6} \frac{0}{6} \frac{J}{7}$ → Refer to the table above.
- (Chip) (CH, RH, UJ, SL)
- 1 = Type
 - 2 = Shape
 - 3 = Dimension
 - 4 = Temp. coefficient
 - 5 = Voltage rating
 - 6 = Value
 - 7 = Tolerance
- (EX) $\frac{C}{1} \frac{K}{2} \frac{7}{3} \frac{F}{3} \frac{F}{4} \frac{1}{5} \frac{H}{5} \frac{0}{6} \frac{0}{6} \frac{0}{6} \frac{Z}{7}$
- (Chip) (B, F)

• Dimension

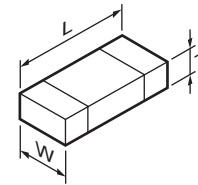

Chip capacitor

Code	L	W	T
Empty	5.6±0.5	5.0±0.5	Less than 2.0
A	4.5±0.5	3.2±0.4	Less than 2.0
B	4.5±0.5	2.0±0.3	Less than 2.0
C	4.5±0.5	1.25±0.2	Less than 1.25
D	3.2±0.4	2.5±0.3	Less than 1.5
E	3.2±0.2	1.6±0.2	Less than 1.25
F	2.0±0.3	1.25±0.2	Less than 1.25
G	1.6±0.2	0.8±0.2	Less than 1.0
H	1.0±0.05	0.5±0.05	0.5±0.05

Chip resistor

Code	L	W	T
E	3.2±0.2	1.6±0.2	1.0
F	2.0±0.3	1.25±0.2	1.0
G	1.6±0.2	0.8±0.2	0.5±0.1
H	1.0±0.05	0.5±0.05	0.35±0.05

RESISTORS

• Chip resistor (Carbon)

- (EX) $\frac{R}{1} \frac{D}{2} \frac{7}{3} \frac{E}{3} \frac{B}{4} \frac{2}{5} \frac{B}{5} \frac{0}{6} \frac{0}{6} \frac{0}{6} \frac{J}{7}$
- (Chip) (B, F)

• Carbon resistor (Normal type)

- (EX) $\frac{R}{1} \frac{D}{2} \frac{1}{3} \frac{4}{3} \frac{B}{4} \frac{B}{4} \frac{2}{5} \frac{C}{5} \frac{0}{6} \frac{0}{6} \frac{0}{6} \frac{J}{7}$

- 1 = Type
- 2 = Shape
- 3 = Dimension
- 4 = Temp. coefficient
- 5 = Rating wattage
- 6 = Value
- 7 = Tolerance

• Rating wattage

Code	Wattage	Code	Wattage	Code	Wattage
1J	1/16W	2C	1/6W	3A	1W
2A	1/10W	2E	1/4W	3D	2W
2B	1/8W	2H	1/2W		

PARTS LIST

△ indicates safety critical components.

Parts without **Parts No.** are not supplied.

Les articles non mentionnés dans le **Parts No.** ne sont pas fournis.

Teile ohne **Parts No.** werden nicht geliefert.

L : Scandinavia

Y : PX (Far East, Hawaii)

C : China

K : USA

T : England

X : Australia

P : Canada

E : Europe

M : Other Areas

TKR-D810 (K,K2)

FINAL UNIT (X45-4020-XX)

Ref. No.	Address	Parts No.	Description	Desti- nation
TKR-D810 (K,K2)				
1	3A	A62-0933-23	PANEL ASSY(INNER)	
2	1A	A62-1146-04	PANEL (TX-RX)	
3	1B	A62-1147-04	PANEL (FINAL)	
4	1D	A62-1148-03	PANEL (OUTER)	
5	3C	A6C-0002-00	PANEL ASSY	
6	2C	A82-0077-12	REAR PANEL	
8	1F	B10-2635-04	FRONT GLASS ACCESSORY	
9	1F	B11-1259-04	FILTER ACCESSORY	
10	1F	B5A-1121-00	INSTRUCTION MANUAL	
11	2C,3D	B4A-0602-00	MODEL NAME- PLATE	K
11	2C,3D	B4A-0603-00	MODEL NAME- PLATE	K2
13	1B	E30-3414-05	DC CORD(EXT DC IN)	
14	1C	E30-3418-25	ANTENNA CABLE (RX IN)	
15	1E	E30-3427-45	DC CORD ACCESSORY	
16	2D	E30-7528-25	ANTENNA CABLE (TX OUT)	
17	1A	E30-7689-05	TRUNK CABLE (X57-X53)	
18	1C	E30-7690-15	ANTENNA CABLE (REF IN)	
19	1E	E31-3228-05	15P PLUG ACCESSORY	
20	1B	E37-0902-15	LEAD WIRE WITH TERMINAL (DC+)	
21	1B	E37-0903-15	LEAD WIRE WITH TERMINAL (DC-)	
22	3A	E37-0905-15	LEAD WIRE WITH CONNECTOR (SP)	
23	3A	E37-0906-05	LEAD WIRE WITH CONNECTOR (X53-X54)	
24	3A,2B	E37-0908-05	LEAD WIRE WITH CONNECTOR (11P)	
25	3A,1B	E37-0911-05	LEAD WIRE WITH CONNECTOR (3P)	
27	2C	E37-0913-05	LEAD WIRE WITH CONNECTOR (ACC15P)	
28	2A	E37-1340-25	FLAT CABLE	
29	2C	E37-1376-05	LEAD WIRE WITH CONNECTOR (DSUB25P)	
26	2B	E37-1638-05	LEAD WIRE WITH MINIPIN PLUG	
33	2C	F09-0445-05	CAP (DSUB)	
34	1C	F09-0471-15	FANMOTOR	
36	1B	F10-3129-13	SHIELDING CASE (X45 FINAL PCB)	
32	1C,1E	F52-0042-05	BLADE FUSE (15A/32V) ACCESSORY	
37	2A,2B	G02-0576-14	FLAT SPRING	
38	2B	G02-0829-14	FLAT SPRING (RX VCO)	
39	2B	G02-0829-14	FLAT SPRING (RX VCO)	K
40	3A	G02-0885-23	EARTH SPRING (X54 DISPLAY PCB)	
41	1B	G02-0894-14	EARTH SPRING (X45:FINAL FET)	
42	2B	G02-1831-04	EARTH SPRING (REAR BOTTOM)	
43	1C	G02-1832-04	EARTH SPRING (REAR TOP)	
44	1B	G02-1855-14	FLAT SPRING(X45-AVR)	
46	2B,3B	G10-1263-04	FIBROUS SHEET (CHASSIS)	
47	3C,2D	G10-1264-04	FIBROUS SHEET (PANEL ASSY)	
48	3B	G10-1344-04	FIBROUS SHEET (EARTH SPRING,SHORT)	
49	3B	G10-1345-04	FIBROUS SHEET (EARTH SPRING,LONG)	
50	3A	G10-1377-04	FIBROUS SHEET (VOLUME)	
51	3A	G10-1821-04	FIBROUS SHEET (KNOB)	
52	1F	G13-1801-04	CUSHION (40X40X5) ACCESSORY	
53	1F	G13-1802-04	CUSHION (40X40X10) ACCESSORY	
54	2B	G13-1886-04	CUSHION(BNC)	
56	2F	H10-6656-01	PACKING FIXTURE (FRONT)	
58	2F	H12-4300-03	PACKING FIXTURE(BOX)	
57	2E	H12-4352-01	PACKING FIXTURE(REAR)	
59	1F	H13-1170-03	CARTON BOARD	
65	3F	H5A-0005-00	ITEM CARTON CASE	

Ref. No.	Address	Parts No.	Description	Desti- nation
67	1E	J02-0475-15	FOOT ACCESSORY	
68	1E	J02-0492-04	FOOT (RUBBER) ACCESSORY	
69	2B	J19-5540-03	HOLDER (TRUNK CABLE)	
70	1B	J21-8467-14	MOUNTING HARDWARE (X45:DRIVE FET)	
71	1F	J21-8559-04	MOUNTING HARDWARE ACCESSORY	
72	1E	J59-0302-05	GROMMET ACCESSORY	
73	1B,1E	J61-0307-05	BAND	
75	1E	K01-0418-15	HANDLE ACCESSORY	
76	3A	K29-5389-03	KNOB (VOLUME)	
77	3A	K29-9370-02	KEY TOP	
78	3A	K29-9454-04	KNOB(POWER)	
80	1E	L79-1419-05	LINE FILTER (ACCESSORY DC CORD)	
81	1B	L79-1854-05	LINE FILTER (DC CORD,DC+,DC-)	
82	1B	L79-1855-05	LINE FILTER (DC+,DC-)	
A	2C	N09-2292-05	HEXAGON HEAD SCREW(D-SUB)	
B	1C,2C,2D	N30-2606-48	PAN HEAD MACHINE SCREW (ANT)	
C	2A,1E	N30-4006-48	PAN HEAD MACHINE SCREW (CHAS,ACC)	
D	2B,2C	N30-4014-48	PAN HEAD MACHINE SCREW (CHASSIS)	
E	1C	N30-4020-43	PAN HEAD MACHINE SCREW (FAN)	
F	1C,2C	N32-3006-48	FLAT HEAD MACHINE SCREW (R PANEL)	
G	3B	N32-4008-43	FLAT HEAD MACHINE SCREW (F PANEL)	
H	1A,1B,1E	N35-3006-43	BINDING HEAD MACHINE SCREW (TOP,ACC)	
J	1C	N35-4006-43	BINDING HEAD MACHINE SCREW (TOP)	
K	1B,3B	N67-3008-48	PAN HEAD SEMS SCREW (X53:AUDIO IC)	
L	1C,2C	N80-2608-43	PAN HEAD TAPTITE SCREW (FUSE)	
M	3A	N87-3005-43	BRAZIER HEAD TAPTITE SCREW (SP)	
N	3A,1B,2B	N87-3006-48	BRAZIER HEAD TAPTITE SCREW (PCB)	
84	3A	T07-0770-45	SPEAKER	
86	3A	W09-0971-05	LITHIUM CELL	
-		X45-4020-10	FINAL UNIT	K2
-		X45-4020-11	FINAL UNIT	K
-		X53-4582-71	SERVICE CONTROL UNIT	
-		X54-4060-20	DISPLAY UNIT	
-		X57-897K-02	TX-RX UNIT	K
-		X57-897K-03	TX-RX UNIT	K2
-		X58-5210-10	RX VCO/PLL UNIT	K2
-		X58-5210-11	RX VCO/PLL UNIT	K
-		X58-5220-10	TX VCO/PLL UNIT	K2
-		X58-5220-11	TX VCO/PLL UNIT	K
-		490-0174-05	ADHESIVE TAPE	
FINAL UNIT (X45-4020-XX) -10:K2 -11:K				
101	2C	E37-1473-05	LEAD WIRE WITH CONNECTOR (X45-X53)	
C1		CK73GB1H471K	CHIP C 470PF K	
C2		CC73GCH1H060D	CHIP C 6.0PF D	
C3		CK73GB1H471K	CHIP C 470PF K	
C4		CK73GB1H104K	CHIP C 0.1UF K	

PARTS LIST

FINAL UNIT (X45-4020-XX)

Ref. No.	Address	Parts No.	Description	Desti- nation	Ref. No.	Address	Parts No.	Description	Desti- nation
C5		CK73GB1H471K	CHIP C 470PF K		C68		CK73GB1H471K	CHIP C 470PF K	
C6		CK73GB1H471K	CHIP C 470PF K		C74		CK73GB1H471K	CHIP C 470PF K	
C8		CC73GCH1H470J	CHIP C 47PF J	K	C76		C93-0572-05	CHIP C 100PF J	
C8		CK73GB1H471K	CHIP C 470PF K	K2	C77		CC73FCH1H030B	CHIP C 3.0PF B	
C9		CC73GCH1H080D	CHIP C 8.0PF D		C79		C93-0551-05	CHIP C 1.5PF C	
C10		CC73GCH1H050B	CHIP C 5.0PF B	K	C80		C93-0551-05	CHIP C 1.5PF C	
C10		CC73GCH1H120J	CHIP C 12PF J	K2	C82		C93-0554-05	CHIP C 4.0PF C	
C11		CC73GCH1H040B	CHIP C 4.0PF B	K	C86		C93-1771-05	CHIP C 7PF C	K
C12		CK73GB1H471K	CHIP C 470PF K		C86		C93-1776-05	CHIP C 9.0PF C	K2
C13		CK73GB1H104K	CHIP C 0.1UF K		C87		CK73GB1H471K	CHIP C 470PF K	
C14		CK73GB1H104K	CHIP C 0.1UF K		C89		C93-1773-05	CHIP C 8.0PF C	K
C16		CK73GB1H471K	CHIP C 470PF K		C89		C93-1778-05	CHIP C 10PF J	K2
C17		CK73GB1H471K	CHIP C 470PF K		C91		C93-0553-05	CHIP C 3.0PF C	
C18		CK73GB1H471K	CHIP C 470PF K		C92		C93-0560-05	CHIP C 10PF D	K
C20		CK73FB1H471K	CHIP C 470PF K		C92		C93-0562-05	CHIP C 15PF J	K2
C22		CC73FCH1H080D	CHIP C 8.0PF D	K	C93		C93-1786-05	CHIP C 22PF J	K
C22		CC73FCH1H120J	CHIP C 12PF J	K2	C94		CC73FCH1H010B	CHIP C 1.0PF B	K
C23		CK73FB1H471K	CHIP C 470PF K		C201		CK73GB1H471K	CHIP C 470PF K	
C24		CC73GCH1H470J	CHIP C 47PF J	K	C204		CK73GB1H471K	CHIP C 470PF K	
C25		CC73GCH1H470J	CHIP C 47PF J	K	C206		CK73GB1H104K	CHIP C 0.1UF K	
C26		CC73GCH1H470J	CHIP C 47PF J	K	C207		CK73GB1H471K	CHIP C 470PF K	
C27		CC73FCH1H060B	CHIP C 6.0PF B	K2	C213		CK73GB1H471K	CHIP C 470PF K	
C27		CK73FB1H471K	CHIP C 470PF K	K	C215		CK73GB1H104K	CHIP C 0.1UF K	
C28		CC73FCH1H060B	CHIP C 6.0PF B	K2	C216		CK73GB1H471K	CHIP C 470PF K	
C28		CC73FCH1H090B	CHIP C 9.0PF B	K	C217		CD04AZ1V100M	ELECTRO 10UF 35WV	
C29		C93-0566-05	CHIP C 33PF J		C218		CK73GB1H471K	CHIP C 470PF K	
C31		C93-0599-05	CHIP C 470PF K		C219		CK73GB1H471K	CHIP C 470PF K	
C32		CK73GB1H471K	CHIP C 470PF K		C220		CD04AZ1V102M	ELECTRO 1000UF 35WV	
C33		C93-0599-05	CHIP C 470PF K		C221		CK73GB1H471K	CHIP C 470PF K	
C34		CC73GCH1H101J	CHIP C 100PF J		C222		CK73GB1H104K	CHIP C 0.1UF K	
C35		CC73FCH1H470J	CHIP C 47PF J	K	C223		CK73GB1H471K	CHIP C 470PF K	
C36		C93-1784-05	CHIP C 18PF J	K	C224		CK73GB1H104K	CHIP C 0.1UF K	
C36		C93-1792-05	CHIP C 39PF J	K2	C225		CK73GB1H471K	CHIP C 470PF K	
C37		CK73GB1H104K	CHIP C 0.1UF K		C226		CK73GB1H471K	CHIP C 470PF K	
C40		CK73GB1H471K	CHIP C 470PF K		C227		CK73GB1H471K	CHIP C 470PF K	
C41		CC73GCH1H220J	CHIP C 22PF J		C228		CK73GB1H471K	CHIP C 470PF K	
C42		C93-1784-05	CHIP C 18PF J	K	C229		CK73GB1H471K	CHIP C 470PF K	
C42		C93-1792-05	CHIP C 39PF J	K2	C230		CK73GB1H471K	CHIP C 470PF K	
C43		C93-0599-05	CHIP C 470PF K		C231		CK73GB1H471K	CHIP C 470PF K	
C44		CC73GCH1H820J	CHIP C 82PF J		C232		CK73GB1H471K	CHIP C 470PF K	
C45		C93-1784-05	CHIP C 18PF J	K	C233		CK73GB1H471K	CHIP C 470PF K	
C45		C93-1792-05	CHIP C 39PF J	K2	C234		CD04BQ1H101M	ELECTRO 100UF 50WV	
C48		C93-1786-05	CHIP C 22PF J	K	C235		CC73GCH1H220J	CHIP C 22PF J	
C48		C93-1789-05	CHIP C 30PF J	K2	C236		CC73GCH1H101J	CHIP C 100PF J	
C49		CC73GCH1H101J	CHIP C 100PF J		C237		CK73GB1H471K	CHIP C 470PF K	
C50		C93-0599-05	CHIP C 470PF K		C238		CK73GB1H471K	CHIP C 470PF K	
C51		C93-1786-05	CHIP C 22PF J	K	C239		CC73GCH1H220J	CHIP C 22PF J	
C51		C93-1788-05	CHIP C 27PF J	K2	C240		CK73GB1H104K	CHIP C 0.1UF K	
C52		CK73GB1H104K	CHIP C 0.1UF K		C241		CK73GB1H471K	CHIP C 470PF K	
C53		CC73FCH1H050C	CHIP C 5.0PF C	K	C242		CK73GB1H471K	CHIP C 470PF K	
C54		C93-1782-05	CHIP C 15PF J		C244		CK73GB1H471K	CHIP C 470PF K	
C56		C93-1771-05	CHIP C 7PF C	K	C245		CK73GB1H471K	CHIP C 470PF K	
C56		C93-1778-05	CHIP C 10PF J	K2	C246		CK73GB1H471K	CHIP C 470PF K	
C57		CC73GCH1H220J	CHIP C 22PF J		C247		CK73GB1H471K	CHIP C 470PF K	
C58		C93-1768-05	CHIP C 6.0PF C		C301		CC73GCH1H470J	CHIP C 47PF J	
C60		CC73GCH1H820J	CHIP C 82PF J		C302		CC73GCH1H220J	CHIP C 22PF J	
C61		C93-0572-05	CHIP C 100PF J	K2	C303		CC73GCH1H150J	CHIP C 15PF J	
C61		C93-0599-05	CHIP C 470PF K	K	C304		CC73GCH1H101J	CHIP C 100PF J	
C62		CK73GB1H471K	CHIP C 470PF K		CN1		E04-0491-05	PIN SOCKET	
C67		C93-0599-05	CHIP C 470PF K		CN3		E23-1262-05	TERMINAL	

PARTS LIST

FINAL UNIT (X45-4020-XX)

Ref. No.	Address	Parts No.	Description	Desti- nation	Ref. No.	Address	Parts No.	Description	Desti- nation
CN4		E23-1330-05	TERMINAL		R1		RK73GB2A181J	CHIP R 180 J 1/10W	K2
CN5		E23-1330-05	TERMINAL		R1		RK73GB2A271J	CHIP R 270 J 1/10W	K
CN6		E23-1330-05	TERMINAL		R2		RK73GB2A180J	CHIP R 18 J 1/10W	K
CN7		E23-1330-05	TERMINAL		R2		RK73GB2A270J	CHIP R 27 J 1/10W	K2
CN8		E23-1262-05	TERMINAL		R3		RK73GB2A181J	CHIP R 180 J 1/10W	K2
CN9		E23-1262-05	TERMINAL		R3		RK73GB2A271J	CHIP R 270 J 1/10W	K
CN10		E23-1262-05	TERMINAL		R4		RK73FB2B151J	CHIP R 150 J 1/8W	
CN11		E23-1330-05	TERMINAL		R5		RK73GB2A392J	CHIP R 3.9K J 1/10W	
CN201		E23-0462-05	TERMINAL		R6		RK73GB2A332J	CHIP R 3.3K J 1/10W	
CN202		E23-0462-05	TERMINAL		R7		RK73GB2A221J	CHIP R 220 J 1/10W	
CN203		E41-2672-05	PIN ASSY		R8		RK73GB2A180J	CHIP R 18 J 1/10W	
CN204		E41-2743-05	PIN ASSY		R10		RK73GB2A123J	CHIP R 12K J 1/10W	
CN205		E41-1682-05	PIN ASSY		R11		RK73FB2B221J	CHIP R 220 J 1/8W	
D1		HSM88AS-E	DIODE		R12		RK73GB2A103J	CHIP R 10K J 1/10W	
D2		MA2S111-F	DIODE		R13		RK73RB2H100J	CHIP R 10 J 1/2W	
D3		HSM88AS-E	DIODE		R14		RK73FB2B221J	CHIP R 220 J 1/8W	
D4		L8103R	DIODE		R16		RK73RB2H821J	CHIP R 820 J 1/2W	
D5		L8103R	DIODE		R17		RK73RB2H5R6J	CHIP R 5.6 J 1/2W	
D6		L8103R	DIODE		R18		RK73RB2H821J	CHIP R 820 J 1/2W	
D7		L8103R	DIODE		R19		RK73FB2B103J	CHIP R 10K J 1/8W	
D8		CSA70-401L	SURGE ABSORBER		R20		RK73EB2E221J	CHIP R 220 J 1/4W	
D9		HVC131	DIODE	K	R21		RK73FB2B123J	CHIP R 12K J 1/8W	
D201		02DZ6.2F-Y	ZENER DIODE		R22		RK73GB2A000J	CHIP R 0.0 J 1/10W	
D202		22ZR-10D	SURGE ABSORBER		R23		RK73GB2A000J	CHIP R 0.0 J 1/10W	
D203		1SS355	DIODE		R24		RK73GB2A000J	CHIP R 0.0 J 1/10W	
D301		DSA3A1	DIODE		R25		RK73GB2A000J	CHIP R 0.0 J 1/10W	
F1		F53-0392-05	FUSE (3A)		R26		RK73FB2B103J	CHIP R 10K J 1/8W	
102	2B	G02-1856-14	EARTH SPRING		R27		RK73RB2H101J	CHIP R 100 J 1/2W	K2
103	2C	J21-8616-24	MOUNTING		R27		RK73RB2H221J	CHIP R 220 J 1/2W	K
CN301		J13-0071-05	FUSE HOLDER		R28		RK73FB2B103J	CHIP R 10K J 1/8W	
IC201		TA75W01FUF	BIPOLAR IC		R29		RK73FB2B000J	CHIP R 0.0 J 1/8W	
IC202		TA75W01FUF	BIPOLAR IC		R30		RK73FB2B750J	CHIP R 75 J 1/8W	
IC203		NJM78M08FA-ZB	ANALOGUE IC		R31		RK73GB2A000J	CHIP R 0.0 J 1/10W	
J401		E58-0533-05	MODULAR JACK		R32		RK73FB2B181J	CHIP R 180 J 1/8W	
J402		E58-0533-05	MODULAR JACK		R33		RK73GB2A274J	CHIP R 270K J 1/10W	
L1		L41-1578-14	SMALL FIXED INDUCTOR (15NH)		R34		RK73GB2A000J	CHIP R 0.0 J 1/10W	
L2		L41-8268-14	SMALL FIXED INDUCTOR (8.2NH)		R35		RK73GB2A000J	CHIP R 0.0 J 1/10W	
L3		L41-1578-14	SMALL FIXED INDUCTOR (15NH)		R36		RK73FB2B000J	CHIP R 0.0 J 1/8W	
L4		LR7920DA8NOG	SMALL FIXED INDUCTOR (8NH)		R37		RK73FB2B000J	CHIP R 0.0 J 1/8W	
L5		L34-4556-05	AIR-CORE COIL		R38		RK73FB2B750J	CHIP R 75 J 1/8W	K
L6		L34-4520-05	AIR-CORE COIL		R38		RK73FB2B820J	CHIP R 82 J 1/8W	K2
L7		L41-1085-14	SMALL FIXED INDUCTOR (100NH)		R39		RK73PB2H121J	CHIP R 120 J 1/2W	
L8		L41-1085-14	SMALL FIXED INDUCTOR(100NH)		R40		RK73GB2A000J	CHIP R 0.0 J 1/10W	
L9		L3E-0023-00	AIR CORE COIL		R41		RK73FB2B224J	CHIP R 220K J 1/8W	
L10		L34-4743-05	AIR CORE COIL	K	R201		RK73GB2A273J	CHIP R 27K J 1/10W	
L10		L34-4758-05	AIR-CORE COIL	K2	R202		RK73GB2A104J	CHIP R 100K J 1/10W	
L11		L34-4517-05	AIR-CORE COIL		R203		RK73GB2A683J	CHIP R 68K J 1/10W	
L12		L34-4517-05	AIR-CORE COIL		R204		RK73GB2A473J	CHIP R 47K J 1/10W	
L13		L34-4517-05	AIR-CORE COIL		R205		RK73GB2A104J	CHIP R 100K J 1/10W	
L14		L41-4763-14	SMALL FIXED INDUCTOR (4.7NH)		R206		RK73GB2A104J	CHIP R 100K J 1/10W	
L15		LB73Z0AF-001	CHIP FERRITE BEADS		R207		RK73GB2A154J	CHIP R 150K J 1/10W	
Q1		2SC5092-F	TRANSISTOR		R209		RK73GB2A104J	CHIP R 100K J 1/10W	K2
Q2		RD01MUS1-T113	FET		R209		RK73GB2A334J	CHIP R 330K J 1/10W	K
Q3	2B	PD55008S-E	FET		R211		RK73GB2A101J	CHIP R 100 J 1/10W	
Q4	2B	RD60HUF1-101	FET		R213		RK73GB2A334J	CHIP R 330K J 1/10W	
Q203		2SJ484	FET		R215		RK73GB2A332J	CHIP R 3.3K J 1/10W	
Q204		2SJ484	FET		R217		RK73GB2A333J	CHIP R 33K J 1/10W	
Q205		SSM3K15TE(F)	FET		R218		RK73GB2A104J	CHIP R 100K J 1/10W	
Q206		SSM3K15TE(F)	FET		R219		RK73GB2A104J	CHIP R 100K J 1/10W	
Q207		PDTD123ET	DIGITAL TRANSISTOR		R220		RK73GB2A224J	CHIP R 220K J 1/10W	

If a part reference number is listed in a shaded box, that part does not come with the PCB.

PARTS LIST

FINAL UNIT (X45-4020-XX)

CONTROL UNIT (X53-4580-10)

Ref. No.	Address	Parts No.	Description	Desti-nation	Ref. No.	Address	Parts No.	Description	Desti-nation
R222		RK73GB2A123J	CHIP R 12K J 1/10W	K	C45		CK73HBB1A104K	CHIP C 0.1UF K	
R222		RK73GB2A473J	CHIP R 47K J 1/10W	K2	C46		CK73HB1A105K	CHIP C 1.0UF K	
R225		RK73GB2A000J	CHIP R 0.0 J 1/10W		C47		CK73HBB1H102K	CHIP C 1000PF K	
R226		RK73GB2A332J	CHIP R 3.3K J 1/10W		C49		CK73HB1A105K	CHIP C 1.0UF K	
R228		RK73GB2A473J	CHIP R 47K J 1/10W		C50		CK73HBB1A104K	CHIP C 0.1UF K	
R229		RK73GB2A473J	CHIP R 47K J 1/10W		C51		CK73HB1A105K	CHIP C 1.0UF K	
R230		RK73GB2A472J	CHIP R 4.7K J 1/10W		C52		CC73HCH1H270J	CHIP C 27PF J	
R231		RK73GB2A472J	CHIP R 4.7K J 1/10W		C56		CK73HBB1A104K	CHIP C 0.1UF K	
R232		RK73GB2A474J	CHIP R 470K J 1/10W		C57		CK73HBB1A104K	CHIP C 0.1UF K	
R233		RK73GB2A474J	CHIP R 470K J 1/10W		C58		CK73HBB1H681K	CHIP C 680PF K	
R235		RK73PB2H100J	CHIP R 10 J 1/2W		C60		CK73HBB1H102K	CHIP C 1000PF K	
R236		RK73PB2H100J	CHIP R 10 J 1/2W		C61		CK73HBB1H102K	CHIP C 1000PF K	
R237		RK73GB2A274J	CHIP R 270K J 1/10W		C62		CK73FBOJ106K	CHIP C 10UF K	
R351		RK73GB2A000J	CHIP R 0.0 J 1/10W	K2	C63		CK73FBOJ106K	CHIP C 10UF K	
R352		RK73GB2A000J	CHIP R 0.0 J 1/10W	K	C64		CK73HB1A105K	CHIP C 1.0UF K	
R355		RK73GB2A000J	CHIP R 0.0 J 1/10W		C65		CK73HBB1H102K	CHIP C 1000PF K	
TH201		S1R103J440H	THERMISTOR		C66		CK73HBB1E103K	CHIP C 0.01UF K	
R355		RK73GB2A000J	CHIP R 0.0 J 1/10W		C67		CK73HBB1A104K	CHIP C 0.1UF K	
TH201		S1R103J440H	THERMISTOR		C68		CK73HBB1E103K	CHIP C 0.01UF K	
					C69		CK73HBB1H102K	CHIP C 1000PF K	
CONTROL UNIT (X53-4580-10)					C70		CK73HB1A224K	CHIP C 0.22UF K	
C7		CC73HCH1H101J	CHIP C 100PF J		C72		CK73HB1A224K	CHIP C 0.22UF K	
C8		CC73HCH1H101J	CHIP C 100PF J		C73		CC73HCH1H470J	CHIP C 47PF J	
C9		CC73HCH1H101J	CHIP C 100PF J		C74		CC73HCH1H101J	CHIP C 100PF J	
C10		CC73HCH1H101J	CHIP C 100PF J		C75		CK73GBB1C104K	CHIP C 0.1UF K	
C11		CK73HB1A105K	CHIP C 1.0UF K		C76		CC73HCH1H470J	CHIP C 47PF J	
C12		CC73HCH1H101J	CHIP C 100PF J		C77		CK73HBB1A104K	CHIP C 0.1UF K	
C13		CC73HCH1H101J	CHIP C 100PF J		C79		CK73HBB1E103K	CHIP C 0.01UF K	
C14		CC73HCH1H101J	CHIP C 100PF J		C80		CK73HBB1E103K	CHIP C 0.01UF K	
C15		CC73HCH1H101J	CHIP C 100PF J		C81		CK73HBB1H102K	CHIP C 1000PF K	
C18		CK73GBB1C104K	CHIP C 0.1UF K		C82		CC73HCH1H101J	CHIP C 100PF J	
C19		CK73GBB1C104K	CHIP C 0.1UF K		C83		CC73HCH1H101J	CHIP C 100PF J	
C20		CK73HB1A105K	CHIP C 1.0UF K		C84		CK73HB1H682K	CHIP C 6800PF K	
C21		CK73GBB1C104K	CHIP C 0.1UF K		C85		CK73HB1H682K	CHIP C 6800PF K	
C22		CK73GBB1C104K	CHIP C 0.1UF K		C86		CK73HB1H682K	CHIP C 6800PF K	
C23		CK73HBB1A104K	CHIP C 0.1UF K		C87		CK73HBB1H102K	CHIP C 1000PF K	
C24		CK73HBB1A104K	CHIP C 0.1UF K		C88		CK73GBB1C104K	CHIP C 0.1UF K	
C25		CK73HBB1A104K	CHIP C 0.1UF K		C89		CK73HBB1H102K	CHIP C 1000PF K	
C26		CK73HBB1A104K	CHIP C 0.1UF K		C90		CK73GBB1C104K	CHIP C 0.1UF K	
C27		CK73HBB1A104K	CHIP C 0.1UF K		C91		CK73HBB1A104K	CHIP C 0.1UF K	
C28		CK73HBB1A104K	CHIP C 0.1UF K		C92		CK73HBB1E103K	CHIP C 0.01UF K	
C29		CK73HBB1A104K	CHIP C 0.1UF K		C93		CS77MPOJ100M	CHIP TNTL 10UF 6.3WV	
C30		CK73HBB1A104K	CHIP C 0.1UF K		C94		CK73HBB1A104K	CHIP C 0.1UF K	
C31		CK73HBB1H102K	CHIP C 1000PF K		C95		CC73HCH1H020C	CHIP C 2.0PF C	
C32		CK73HBB1A104K	CHIP C 0.1UF K		C96		CC73HCH1H020C	CHIP C 2.0PF C	
C33		CK73HBB1A104K	CHIP C 0.1UF K		C97		CK73HBB1H102K	CHIP C 1000PF K	
C34		CK73HB1A105K	CHIP C 1.0UF K		C98		CK73HBB1A104K	CHIP C 0.1UF K	
C35		CK73GBB1C104K	CHIP C 0.1UF K		C99		CK73HBB1A104K	CHIP C 0.1UF K	
C36		CK73GBB1C104K	CHIP C 0.1UF K		C100		CK73GB1E104K	CHIP C 0.10UF K	
C38		CK73HBB1H102K	CHIP C 1000PF K		C101		CK73HBB1E103K	CHIP C 0.01UF K	
C39		CK73HBB1A104K	CHIP C 0.1UF K		C102		CK73HB1A105K	CHIP C 1.0UF K	
C40		CK73HB1A105K	CHIP C 1.0UF K		C103		CK73HBB1H102K	CHIP C 1000PF K	
C41		CK73HBB1A104K	CHIP C 0.1UF K		C104		CK73GBB1C104K	CHIP C 0.1UF K	
C42		CK73HBB1A104K	CHIP C 0.1UF K		C105		CK73GB1E104K	CHIP C 0.10UF K	
C43		CK73HBB1A104K	CHIP C 0.1UF K		C106		CK73GB1E104K	CHIP C 0.10UF K	
C44		CK73HBB1A104K	CHIP C 0.1UF K		C107		CK73GBB1C104K	CHIP C 0.1UF K	
					C108		CC73HCH1H020C	CHIP C 2.0PF C	
					C109		CS77MPOJ100M	CHIP TNTL 10UF 6.3WV	
					C110		CC73HCH1H101J	CHIP C 100PF J	
					C111		CC73HCH1H101J	CHIP C 100PF J	

PARTS LIST

CONTROL UNIT (X53-4580-10)

Ref. No.	Address	Parts No.	Description	Desti- nation	Ref. No.	Address	Parts No.	Description	Desti- nation
C112		CK73HBB1A104K	CHIP C 0.1UF K		C184		CK73HBB1H102K	CHIP C 1000PF K	
C114		CC73HCH1H101J	CHIP C 100PF J		C185		CK73HBB1H102K	CHIP C 1000PF K	
C115		CK73HBB1A104K	CHIP C 0.1UF K		C186		CC73HCH1H101J	CHIP C 100PF J	
C116		CK73HBB1A104K	CHIP C 0.1UF K		C187		CK73HBB1H102K	CHIP C 1000PF K	
C117		CK73HBB1A104K	CHIP C 0.1UF K		C188		CC73HCH1H101J	CHIP C 100PF J	
C118		CK73HBB1A104K	CHIP C 0.1UF K		C189		CK73HBB1H102K	CHIP C 1000PF K	
C119		CK73HBB1A104K	CHIP C 0.1UF K		C190		CC73HCH1H101J	CHIP C 100PF J	
C120		CK73HB1A105K	CHIP C 1.0UF K		C191		CK73HBB1H102K	CHIP C 1000PF K	
C121		CK73HBB1H102K	CHIP C 1000PF K		C192		CK73HBB1E103K	CHIP C 0.01UF K	
C122		CK73HBB1A104K	CHIP C 0.1UF K		C193		CC73HCH1H101J	CHIP C 100PF J	
C123		CK73HBB1A104K	CHIP C 0.1UF K		C194		CK73HBB1H102K	CHIP C 1000PF K	
C124		CK73HBB1A104K	CHIP C 0.1UF K		C195		CK73HBB1H102K	CHIP C 1000PF K	
C125		CK73HBB1A104K	CHIP C 0.1UF K		C196		CK73HBB1H102K	CHIP C 1000PF K	
C126		CK73HBB1A104K	CHIP C 0.1UF K		C197		CK73HBB1H102K	CHIP C 1000PF K	
C127		CK73HBB1E103K	CHIP C 0.01UF K		C198		CC73HCH1H101J	CHIP C 100PF J	
C128		CK73HB1A105K	CHIP C 1.0UF K		C199		CK73HBB1E103K	CHIP C 0.01UF K	
C129		CK73HBB1H102K	CHIP C 1000PF K		C200		CC73HCH1H101J	CHIP C 100PF J	
C130		CK73HBB1A104K	CHIP C 0.1UF K		C201		CK73HBB1H102K	CHIP C 1000PF K	
C131		CK73HBB1A104K	CHIP C 0.1UF K		C202		CC73HCH1H101J	CHIP C 100PF J	
C132		CK73HBB1E103K	CHIP C 0.01UF K		C203		CK73HBB1H102K	CHIP C 1000PF K	
C133		CK73HBB1H102K	CHIP C 1000PF K		C205		CK73HBB1H102K	CHIP C 1000PF K	
C134		CK73HBB1E103K	CHIP C 0.01UF K		C206		CC73HCH1H101J	CHIP C 100PF J	
C135		CK73HBB1H102K	CHIP C 1000PF K		C207		CK73HBB1E103K	CHIP C 0.01UF K	
C136		CK73HBB1H102K	CHIP C 1000PF K		C209		CK73HBB1H102K	CHIP C 1000PF K	
C137		CK73HBB1E103K	CHIP C 0.01UF K		C210		CK73HBB1H102K	CHIP C 1000PF K	
C138		CC73HCH1H101J	CHIP C 100PF J		C211		CK73HBB1H102K	CHIP C 1000PF K	
C139		CK73HBB1E103K	CHIP C 0.01UF K		C212		CK73HBB1H102K	CHIP C 1000PF K	
C140		CK73GBB1C104K	CHIP C 0.1UF K		C213		CK73HBB1E103K	CHIP C 0.01UF K	
C141		CK73HBB1H102K	CHIP C 1000PF K		C215		CK73HBB1H102K	CHIP C 1000PF K	
C142		CK73HBB1H102K	CHIP C 1000PF K		C216		CK73HBB1H102K	CHIP C 1000PF K	
C143		CK73HBB1E103K	CHIP C 0.01UF K		C218		CC73HCH1H101J	CHIP C 100PF J	
C144		CK73HBB1H102K	CHIP C 1000PF K		C219		CK73HBB1H102K	CHIP C 1000PF K	
C145		CK73HBB1H102K	CHIP C 1000PF K		C220		CK73HBB1H102K	CHIP C 1000PF K	
C146		CK73HBB1H102K	CHIP C 1000PF K		C221		CK73HBB1H102K	CHIP C 1000PF K	
C147		CK73HBB1E103K	CHIP C 0.01UF K		C222		CK73HBB1H102K	CHIP C 1000PF K	
C148		CK73HB1H122K	CHIP C 1200PF K		C223		CK73HBB1H102K	CHIP C 1000PF K	
C149		CK73HBB1H102K	CHIP C 1000PF K		C224		CC73HCH1H101J	CHIP C 100PF J	
C150		CK73HBB1E103K	CHIP C 0.01UF K		C225		CK73HBB1H102K	CHIP C 1000PF K	
C151		CK73HBB1H102K	CHIP C 1000PF K		C226		CC73HCH1H101J	CHIP C 100PF J	
C152		CK73HBB1H102K	CHIP C 1000PF K		C227		CC73HCH1H101J	CHIP C 100PF J	
C153		CK73HBB1H102K	CHIP C 1000PF K		C228		CK73HBB1H102K	CHIP C 1000PF K	
C154		CC73HCH1H101J	CHIP C 100PF J		C229		CK73HBB1H102K	CHIP C 1000PF K	
C155		CK73HBB1H102K	CHIP C 1000PF K		C230		CC73HCH1H101J	CHIP C 100PF J	
C156		CC73HCH1H221J	CHIP C 220PF J		C232		CC73HCH1H101J	CHIP C 100PF J	
C157		CC73HCH1H101J	CHIP C 100PF J		C233		CC73HCH1H101J	CHIP C 100PF J	
C158		CK73HBB1A104K	CHIP C 0.1UF K		C235		CK73HBB1E103K	CHIP C 0.01UF K	
C159		CK73HBB1E103K	CHIP C 0.01UF K		C237		CC73HCH1H101J	CHIP C 100PF J	
C160		CC73HCH1H101J	CHIP C 100PF J		C239		CC73HCH1H101J	CHIP C 100PF J	
C161		CK73HBB1H102K	CHIP C 1000PF K		C240		CK73HBB1H102K	CHIP C 1000PF K	
C162		CC73HCH1H101J	CHIP C 100PF J		C241		CK73HBB1H102K	CHIP C 1000PF K	
C164		CK73HBB1H102K	CHIP C 1000PF K		C242		CK73HBB1H102K	CHIP C 1000PF K	
C166		CK73HBB1E103K	CHIP C 0.01UF K		C243		CC73HCH1H101J	CHIP C 100PF J	
C167		CC73HCH1H101J	CHIP C 100PF J		C244		CK73HBB1H102K	CHIP C 1000PF K	
C170		CK73HBB1H102K	CHIP C 1000PF K		C245		CC73HCH1H101J	CHIP C 100PF J	
C171		CK73HBB1H102K	CHIP C 1000PF K		C246		CC73HCH1H101J	CHIP C 100PF J	
C175		CK73HBB1H102K	CHIP C 1000PF K		C247		CK73HBB1H102K	CHIP C 1000PF K	
C176		CK73HBB1H102K	CHIP C 1000PF K		C249		CK73HBB1H102K	CHIP C 1000PF K	
C179		CK73HBB1H102K	CHIP C 1000PF K		C250		CC73HCH1H101J	CHIP C 100PF J	
C180		CK73HBB1H102K	CHIP C 1000PF K		C252		CK73HBB1H102K	CHIP C 1000PF K	
C182		CK73HBB1H102K	CHIP C 1000PF K		C254		CC73HCH1H101J	CHIP C 100PF J	

TKR-D810

PARTS LIST

CONTROL UNIT (X53-4580-10)

Ref. No.	Address	Parts No.	Description	Desti- nation	Ref. No.	Address	Parts No.	Description	Desti- nation
C256		CC73HCH1H101J	CHIP C 100PF J		C423		CK73HBB1H471K	CHIP C 470PF K	
C257		CK73HBB1H102K	CHIP C 1000PF K		C424		CC73HCH1H331J	CHIP C 330PF J	
C258		CC73HCH1H101J	CHIP C 100PF J		C425		CD04AY1E470M	ELECTRO 47UF 25WV	
C259		CK73HBB1A104K	CHIP C 0.1UF K		C426		CK73HBB1A104K	CHIP C 0.1UF K	
C260		CK73HBB1A104K	CHIP C 0.1UF K		C427		CK73HBB1H471K	CHIP C 470PF K	
C301		C92-0905-05	OS-CON 47UF 35WV		C428		CK73HB1A105K	CHIP C 1.0UF K	
C302		C92-0905-05	OS-CON 47UF 35WV		C429		CK73HBB1A104K	CHIP C 0.1UF K	
C303		C93-1810-05	CHIP C 4.7UF K		C430		CD04CK1E102M	ELECTRO 1000UF M	
C304		C93-1810-05	CHIP C 4.7UF K		C432		CK73HBB1A104K	CHIP C 0.1UF K	
C306		CK73HBB1H471K	CHIP C 470PF K		C433		CC73HCH1H181J	CHIP C 180PF J	
C308		CK73EBB1H474K	CHIP C 0.47UF K		C434		CC73HCH1H101J	CHIP C 100PF J	
C310		CE32AU1C330M	CHIP EL 33UF 6WV		C435		CC73HCH1H101J	CHIP C 100PF J	
C311		CE32AU1C330M	CHIP EL 33UF 16WV		C436		CC73HCH1H221J	CHIP C 220PF J	
C312		CE32BM1E470M	CHIP EL 47UF 25WV		C438		C93-1824-05	CHIP C 100UF M	
C313		CK73HBB1E223K	CHIP C 0.022UF K		C441		C93-1824-05	CHIP C 100UF M	
C314		CK73HBB1H102K	CHIP C 1000PF K		C442		CK73HB1A105K	CHIP C 1.0UF K	
C315		CE32BM1E470M	CHIP EL 47UF 25WV		C443		CK73HBB1A104K	CHIP C 0.1UF K	
C316		CE32BM1E470M	CHIP EL 47UF 25WV		C445		CK73HB1A105K	CHIP C 1.0UF K	
C317		CE32BM1E470M	CHIP EL 47UF 25WV		C446		CK73HBB1A104K	CHIP C 0.1UF K	
C318		CK73HBB1H102K	CHIP C 1000PF K		C450		CK73HB1A105K	CHIP C 1.0UF K	
C319		CK73HBB1H102K	CHIP C 1000PF K		C451		CK73HB1A105K	CHIP C 1.0UF K	
C320		CK73HBB1H102K	CHIP C 1000PF K		C455		CC73HCH1H101J	CHIP C 100PF J	
C321		CK73HBB1H102K	CHIP C 1000PF K		C456		CC73HCH1H221J	CHIP C 220PF J	
C322		CE32BM1E470M	CHIP EL 47UF 25WV		C457		CK73HB1A105K	CHIP C 1.0UF K	
C323		CK73HBB1H102K	CHIP C 1000PF K		C459		CC73HCH1H221J	CHIP C 220PF J	
C324		CE32BM1E470M	CHIP EL 47UF 25WV		C460		CK73HBB1A104K	CHIP C 0.1UF K	
C325		CK73HBB1H102K	CHIP C 1000PF K		C461		CK73HBB1A104K	CHIP C 0.1UF K	
C326		CK73HBB1H102K	CHIP C 1000PF K		C462		CK73HBB1A104K	CHIP C 0.1UF K	
C327		CE32BM1E470M	CHIP EL 47UF 25WV		C463		CC73HCH1H331J	CHIP C 330PF J	
C328		CE32BM1E470M	CHIP EL 47UF 25WV		C464		CC73HCH1H101J	CHIP C 100PF J	
C329		CE32BM1E470M	CHIP EL 47UF 25WV		C465		CK73HBB1H152K	CHIP C 1500PF K	
C330		CK73HBB1H102K	CHIP C 1000PF K		C466		CK73HB1A105K	CHIP C 1.0UF K	
C331		CK73HBB1H102K	CHIP C 1000PF K		C469		CK73HB1A105K	CHIP C 1.0UF K	
C332		CE32BM1E470M	CHIP EL 47UF 25WV		C470		CK73HBB1H102K	CHIP C 1000PF K	
C333		CK73HBB1A104K	CHIP C 0.1UF K		C471		CK73HBB1H102K	CHIP C 1000PF K	
C334		CK73HBB1E103K	CHIP C 0.01UF K		C472		CK73HBB1E103K	CHIP C 0.01UF K	
C335		CK73HBB1H471K	CHIP C 470PF K		C473		CK73HBB1E103K	CHIP C 0.01UF K	
C336		CK73HBB1E103K	CHIP C 0.01UF K		C474		CK73HBB1H102K	CHIP C 1000PF K	
C337		CK73HBB1H102K	CHIP C 1000PF K		C610		CK73GB1E104K	CHIP C 0.10UF K	
C401		CK73HBB1E103K	CHIP C 0.01UF K		C611		CK73GB1E104K	CHIP C 0.10UF K	
C402		CC73HCH1H101J	CHIP C 100PF J		C612		CK73HB1H103K	CHIP C 10000PF K	
C403		CK73HB1A105K	CHIP C 1.0UF K		C613		CK73GB1E105K	CHIP C 1.0UF K	
C404		C90-4120-05	ELECTRO 470UF 35WV		C614		CK73HBB1H102K	CHIP C 1000PF K	
C405		CK73HBB1A104K	CHIP C 0.1UF K		CN5		E41-1481-05	PIN ASSY	
C406		CK73HB1A105K	CHIP C 1.0UF K		CN38		E40-6656-05	PIN ASSY	
C407		CK73HB1A105K	CHIP C 1.0UF K		CN39		E04-0193-05	PIN SOCKET	
C408		C93-1824-05	CHIP C 100UF M		CN40		E40-6102-05	PIN ASSY	
C409		C93-1824-05	HIP C 100UF M		CN41		E41-3086-05	PIN ASSY	
C410		CK73HB1A105K	CHIP C 1.0UF K		CN42		E41-3090-05	PIN ASSY	
C412		CK73FB0J106K	CHIP C 10UF K		CN43		E41-2671-05	PIN ASSY	
C413		CK73HBB1H102K	CHIP C 1000PF K		CN44		E40-5960-05	PIN ASSY	
C414		CK73HB1A105K	CHIP C 1.0UF K		CN301		E41-2672-05	PIN ASSY	
C415		CD04AY1E470M	ELECTRO 47UF 25WV		CN302		J19-5386-05	HOLDER	
C416		CK73HBB1H102K	CHIP C 1000PF K		CP1		RK74HB1J334J	CHIP-COM 330K J 1/16W	
C417		CK73HBB1H222K	CHIP C 0.022UF K		CP2		RK74HB1J334J	CHIP-COM 330K J 1/16W	
C418		CC73HCH1H391J	CHIP C 390PF J		CP3		RK74HB1J334J	CHIP-COM 330K J 1/16W	
C419		CK73HBB1H152K	CHIP C 1500PF K		CP4		RK74HB1J334J	CHIP-COM 330K J 1/16W	
C420		CC73HCH1H221J	CHIP C 220PF J		CP5		RK74HB1J334J	CHIP-COM 330K J 1/16W	
C421		CK73FB0J106K	CHIP C 10UF K		CP6		RK74HB1J334J	CHIP-COM 330K J 1/16W	
C422		CD04AY1E470M	ELECTRO 47UF 25WV		CP7		RK74HB1J334J	CHIP-COM 330K J 1/16W	

PARTS LIST

CONTROL UNIT (X53-4580-10)

Ref. No.	Address	Parts No.	Description	Desti- nation	Ref. No.	Address	Parts No.	Description	Desti- nation
CP8		RK74HB1J334J	CHIP-COM 330K J 1/16W		IC26		TC7SET08FU-F	MOS-IC	
D1		KDR731	DIODE		IC27		TC75W51FK (F)	MOS-IC	
D2		MA2S111-F	DIODE		IC28		TC75S51FE (F)	MOS-IC	
D3		1SS388F	DIODE		IC301		LT3685EMSE	ANALOGUE IC	
D4		DA204U	MULTIPLE DIODE		IC302		XC6201P502P-G	MOS-IC	
D5		DA204U	MULTIPLE DIODE		IC303		NJM2830U133ZB	ANALOGUE IC	
D6		DA204U	MULTIPLE DIODE		IC304		XC6205B152P-G	MOS-IC	
D7		DA204U	MULTIPLE DIODE		IC305		XC6205B162P-G	MOS-IC	
D8		DA204U	MULTIPLE DIODE		IC306		XC6204B332P-G	MOS-IC	
D9		DA204U	MULTIPLE DIODE		IC307		XC61CN2702N-G	MOS-IC	
D10		DA204U	MULTIPLE DIODE		IC308		XC6109C29AN-G	MOS-IC	
D11		DA204U	MULTIPLE DIODE		IC401		TC7SH00FU-F	MOS-IC	
D12		1SS355	DIODE		IC402		TC7S66FUF	MOS-IC	
D13		DZ2J180 (M)	ZENER DIODE		IC403	3B	LA4422-E	BI-POLAR IC	
D14		DA204U	MULTIPLE DIODE		IC404		NJM2732V	BIPOLAR IC	
D15		DA204U	MULTIPLE DIODE		IC405		NJM2734V	BI-POLAR IC	
D16		DA204U	MULTIPLE DIODE		IC406		NJM2732V	BIPOLAR IC	
D18		DA204U	MULTIPLE DIODE		IC407		TC7W53FKF	MOS-IC	
D20		DA204U	MULTIPLE DIODE		IC411		NJM2734V	BI-POLAR IC	
D22		DA204U	MULTIPLE DIODE		IC412		M62364FP-F	MOS-IC	
D23		1SS355	DIODE		L1		LB73G0AK-001	CHIP FERRITE BEADS	
D24		DZ2J180 (M)	ZENER DIODE		L2		L33-1500-05	CHOKE COIL	
D26		DA204U	MULTIPLE DIODE		L3		L33-1500-05	CHOKE COIL	
D28		DA204U	MULTIPLE DIODE		L4		LB73G0AK-001	CHIP FERRITE BEADS	
D29		1SS355	DIODE		L5		LB73H0AV-002	CHIP FERRITE BEADS	
D30		DZ2J180 (M)	ZENER DIODE		L6		LB73H0AV-002	CHIP FERRITE BEADS	
D31		1SS355	DIODE		L7		LB73H0AV-002	CHIP FERRITE BEADS	
D32		DZ2J180 (M)	ZENER DIODE		L8		LB73G0AM-004	CHIP FERRITE BEADS	
D35		1SS355	DIODE		L9		LB73G0AK-001	CHIP FERRITE BEADS	
D36		DZ2J180 (M)	ZENER DIODE		L10		LB73G0AK-001	CHIP FERRITE BEADS	
D37		SMD185F-2	VARISTOR		L11		LB73G0AK-001	CHIP FERRITE BEADS	
D301		SMAB33L-P	DIODE		L14		LB73G0AK-001	CHIP FERRITE BEADS	
D302		1SS388F	DIODE		L15		LB73G0AK-001	CHIP FERRITE BEADS	
D303		DZ2J180 (M)	ZENER DIODE		L16		LB73G0AK-001	CHIP FERRITE BEADS	
D304		1SS388F	DIODE		L17		LB73G0AM-004	CHIP FERRITE BEADS	
D305		1SS388F	DIODE		L18		LB73H0AV-002	CHIP FERRITE BEADS	
D401		1SS388F	DIODE		L20		LB73H0AV-002	CHIP FERRITE BEADS	
IC3		E29PL032A70TI	ROM IC		L22		L92-0171-05	BEADS CORE	
IC4		ISL8485EIBZ	MOS-IC		L23		L92-0171-05	BEADS CORE	
IC5		ISL8485EIBZ	MOS-IC		L301		LB73G0AM-004	CHIP FERRITE BEADS	
IC6		Note 1 (BGA)	MPU IC		L302		LB73G0AM-004	CHIP FERRITE BEADS	
IC7		TC7WT125FUF	MOS-IC		L303		LB73G0AM-004	CHIP FERRITE BEADS	
IC8		TC7WT125FUF	MOS-IC		L304		LB73G0AM-004	CHIP FERRITE BEADS	
IC9		Note 1 (BGA)	SRAM IC		L305		L33-1541-05	SMALL FIXED INDUCTOR (10UH)	
IC10		TC7SH125FU-F	MOS-IC		L306		LB73G0AK-001	CHIP FERRITE BEADS	
IC11		TC7SH125FU-F	MOS-IC		L307		LB73G0AK-001	CHIP FERRITE BEADS	
IC12		TC7SH08FU-F	MOS-IC		L308		LB73G0AK-001	CHIP FERRITE BEADS	
IC13		TC75W51FK (F)	MOS-IC		L309		LB73G0AK-001	CHIP FERRITE BEADS	
IC14		AK4386VTP	MOS-IC		L311		LB73H0AV-002	CHIP FERRITE BEADS	
IC15		TC75W51FK (F)	MOS-IC		L312		LB73G0AK-001	CHIP FERRITE BEADS	
IC16		SM5023CNDH-G	MOS-IC		L313		LB73G0AM-004	CHIP FERRITE BEADS	
IC17		R2023T	MOS-IC		L314		LB73G0AM-004	CHIP FERRITE BEADS	
IC18		TC74VHCT244AFK	MOS-IC		L315		LB73G0AK-001	CHIP FERRITE BEADS	
IC19		TC7MBD3245AFK	MOS-IC		L316		LB73G0AK-001	CHIP FERRITE BEADS	
IC20		Note 1 (BGA)	MOS-IC		L317		LB73G0AK-001	CHIP FERRITE BEADS	
IC21		ADM202EARUZ	MOS-IC		Q4		2SC4617/S/	TRANSISTOR	
IC22		MCP23017TE/ML	MOS-IC		Q5		SSM3K15TE(F)	FET	
IC23		TC7WT125FUF	MOS-IC		Q6		2SD2114K(W)	TRANSISTOR	
IC24		TC7SH08FU-F	MOS-IC		Q7		2SD2114K(W)	TRANSISTOR	
IC25		TC7SH32FU-F	MOS-IC		Q8		2SD2114K(W)	TRANSISTOR	

**Note 1: This part cannot be replaced. Therefore, this part is not supplied as a service part.
If a part reference number is listed in a shaded box, that part does not come with the PCB.**

TKR-D810

PARTS LIST

CONTROL UNIT (X53-4580-10)

Ref. No.	Address	Parts No.	Description	Desti- nation	Ref. No.	Address	Parts No.	Description	Desti- nation
Q9		2SD2114K(W)	TRANSISTOR		R59		RK73HB1J000J	CHIP R 0.0 J 1/16W	
Q10		2SD2114K(W)	TRANSISTOR		R60		RK73HB1J000J	CHIP R 0.0 J 1/16W	
Q301		LTC044EEBFS8	DIGITAL TRANSISTOR		R61		RK73HB1J000J	CHIP R 0.0 J 1/16W	
Q302		SSM3K15TE (F)	FET		R62		RK73HB1J101J	CHIP R 100 J 1/16W	
Q303		2SA1955A-F	TRANSISTOR		R63		RK73HB1J000J	CHIP R 0.0 J 1/16W	
Q401		RT1N141M-T111	TRANSISTOR		R68		RK73HB1J000J	CHIP R 0.0 J 1/16W	
Q402		2SJ506-E (S)	FET		R69		RK73HB1J000J	CHIP R 0.0 J 1/16W	
Q403		LTC044EUBFS8	DIGITAL TRANSISTOR		R70		RK73HB1J000J	CHIP R 0.0 J 1/16W	
Q404		RT1N141M-T111	TRANSISTOR		R71		RK73HB1J000J	CHIP R 0.0 J 1/16W	
Q405		KRC401-P	DIGITAL TRANSISTOR		R72		RK73HB1J000J	CHIP R 0.0 J 1/16W	
Q602		RT1N141M-T111	TRANSISTOR		R73		RK73HB1J000J	CHIP R 0.0 J 1/16W	
R3		RK73HB1J104J	CHIP R 100K J 1/16W		R74		RK73HB1J104J	CHIP R 100K J 1/16W	
R4		RK73HB1J104J	CHIP R 100K J 1/16W		R75		RK73HB1J104J	CHIP R 100K J 1/16W	
R5		RK73HB1J104J	CHIP R 100K J 1/16W		R77		RK73HB1J151J	CHIP R 150 J 1/16W	
R6		RK73HB1J104J	CHIP R 100K J 1/16W		R78		RK73HB1J102J	CHIP R 1.0K J 1/16W	
R7		RK73HB1J104J	CHIP R 100K J 1/16W		R79		RK73HB1J000J	CHIP R 0.0 J 1/16W	
R8		RK73HB1J104J	CHIP R 100K J 1/16W		R80		RK73HB1J823J	CHIP R 82K J 1/16W	
R9		RK73HB1J104J	CHIP R 100K J 1/16W		R81		RK73HB1J104J	CHIP R 100K J 1/16W	
R10		RK73EB2E101J	CHIP R 100 J 1/4W		R82		RK73HB1J104J	CHIP R 100K J 1/16W	
R11		RK73EB2E101J	CHIP R 100 J 1/4W		R83		RK73HB1J104J	CHIP R 100K J 1/16W	
R12		RK73EB2E101J	CHIP R 100 J 1/4W		R85		RK73HB1J103J	CHIP R 10K J 1/16W	
R13		RK73EB2E101J	CHIP R 100 J 1/4W		R87		RK73HB1J334J	CHIP R 330K J 1/16W	
R14		RK73HB1J000J	CHIP R 0.0 J 1/16W		R88		RK73HB1J100J	CHIP R 10 J 1/16W	
R15		RK73HB1J104J	CHIP R 100K J 1/16W		R89		RK73HB1J332J	CHIP R 3.3K J 1/16W	
R18		RK73HB1J104J	CHIP R 100K J 1/16W		R90		RK73HB1J471J	CHIP R 470 J 1/16W	
R22		RK73HB1J104J	CHIP R 100K J 1/16W		R92		RK73HB1J104J	CHIP R 100K J 1/16W	
R23		RK73HB1J104J	CHIP R 100K J 1/16W		R93		RK73HB1J104J	CHIP R 100K J 1/16W	
R24		RK73HB1J000J	CHIP R 0.0 J 1/16W		R94		RK73HB1J104J	CHIP R 100K J 1/16W	
R25		RK73HB1J103J	CHIP R 10K J 1/16W		R95		RK73HB1J220J	CHIP R 22 J 1/16W	
R26		RK73HB1J103J	CHIP R 10K J 1/16W		R99		RK73HB1J104J	CHIP R 100K J 1/16W	
R27		RK73HB1J473J	CHIP R 47K J 1/16W		R100		RK73HB1J104J	CHIP R 100K J 1/16W	
R28		RK73HB1J473J	CHIP R 47K J 1/16W		R101		RK73HB1J103J	CHIP R 10K J 1/16W	
R29		RK73HB1J000J	CHIP R 0.0 J 1/16W		R102		RK73HB1J104J	CHIP R 100K J 1/16W	
R30		RK73HB1J474J	CHIP R 470K J 1/16W		R103		RK73HB1J104J	CHIP R 100K J 1/16W	
R32		RK73HB1J472J	CHIP R 4.7K J 1/16W		R104		RK73HB1J393J	CHIP R 39K J 1/16W	
R33		RK73HB1J472J	CHIP R 4.7K J 1/16W		R105		RK73HB1J334J	CHIP R 330K J 1/16W	
R34		RK73HB1J104J	CHIP R 100K J 1/16W		R106		RK73HB1J100J	CHIP R 10 J 1/16W	
R35		RK73HB1J104J	CHIP R 100K J 1/16W		R107		RK73HB1J103J	CHIP R 10K J 1/16W	
R36		RK73HB1J104J	CHIP R 100K J 1/16W		R108		RK73HB1J184J	CHIP R 180K J 1/16W	
R37		RK73HB1J103J	CHIP R 10K J 1/16W		R109		RK73HB1J104J	CHIP R 100K J 1/16W	
R38		RK73HB1J104J	CHIP R 100K J 1/16W		R110		RK73HB1J682J	CHIP R 6.8K J 1/16W	
R40		RK73HB1J104J	CHIP R 100K J 1/16W		R111		RK73HB1J104J	CHIP R 100K J 1/16W	
R41		RK73HB1J104J	CHIP R 100K J 1/16W		R112		RK73HB1J104J	CHIP R 100K J 1/16W	
R42		RK73HB1J104J	CHIP R 100K J 1/16W		R113		RK73HB1J102J	CHIP R 1.0K J 1/16W	
R43		RK73HB1J000J	CHIP R 0.0 J 1/16W		R114		RK73HB1J220J	CHIP R 22 J 1/16W	
R44		RK73HB1J000J	CHIP R 0.0 J 1/16W		R115		RK73HB1J220J	CHIP R 22 J 1/16W	
R45		RK73HB1J000J	CHIP R 0.0 J 1/16W		R116		RK73HB1J472J	CHIP R 4.7K J 1/16W	
R46		RK73HB1J000J	CHIP R 0.0 J 1/16W		R117		RK73HB1J472J	CHIP R 4.7K J 1/16W	
R47		RK73HB1J000J	CHIP R 0.0 J 1/16W		R118		RK73HB1J000J	CHIP R 0.0 J 1/16W	
R48		RK73HB1J000J	CHIP R 0.0 J 1/16W		R119		RK73HB1J474J	CHIP R 470K J 1/16W	
R49		RK73HB1J000J	CHIP R 0.0 J 1/16W		R121		RK73HB1J104J	CHIP R 100K J 1/16W	
R50		RK73HB1J000J	CHIP R 0.0 J 1/16W		R122		RK73HB1J103J	CHIP R 10K J 1/16W	
R51		RK73HB1J104J	CHIP R 100K J 1/16W		R123		RK73HB1J473J	CHIP R 47K J 1/16W	
R52		RK73HB1J220J	CHIP R 22 J 1/16W		R124		RK73HB1J103J	CHIP R 10K J 1/16W	
R53		RK73HB1J104J	CHIP R 100K J 1/16W		R125		RK73GB2A564J	CHIP R 560K J 1/10W	
R54		RK73HB1J104J	CHIP R 100K J 1/16W		R126		RK73HB1J104J	CHIP R 100K J 1/16W	
R55		RK73HB1J104J	CHIP R 100K J 1/16W		R127		RK73HB1J102J	CHIP R 1.0K J 1/16W	
R56		RK73HB1J104J	CHIP R 100K J 1/16W		R128		RK73HB1J104J	CHIP R 100K J 1/16W	
R57		RK73HB1J104J	CHIP R 100K J 1/16W		R129		RK73HB1J101J	CHIP R 100 J 1/16W	
R58		RK73HB1J101J	CHIP R 100 J 1/16W		R130		RK73HB1J101J	CHIP R 100 J 1/16W	

PARTS LIST

CONTROL UNIT (X53-4580-10)

Ref. No.	Address	Parts No.	Description	Desti- nation	Ref. No.	Address	Parts No.	Description	Desti- nation
R131		RK73HB1J472J	CHIP R 4.7K J 1/16W		R207		RK73HB1J102J	CHIP R 1.0K J 1/16W	
R132		RK73HB1J102J	CHIP R 1.0K J 1/16W		R208		RK73HB1J102J	CHIP R 1.0K J 1/16W	
R133		RK73HB1J472J	CHIP R 4.7K J 1/16W		R209		RK73HB1J121J	CHIP R 120 J 1/16W	
R135		RK73HB1J104J	CHIP R 100K J 1/16W		R210		RK73HB1J102J	CHIP R 1.0K J 1/16W	
R137		RK73HB1J104J	CHIP R 100K J 1/16W		R211		RK73HB1J101J	CHIP R 100 J 1/16W	
R138		RK73HB1J104J	CHIP R 100K J 1/16W		R212		RK73HB1J101J	CHIP R 100 J 1/16W	
R141		RK73HB1J104J	CHIP R 100K J 1/16W		R213		RK73HB1J101J	CHIP R 100 J 1/16W	
R142		RK73HB1J104J	CHIP R 100K J 1/16W		R214		RK73HB1J102J	CHIP R 1.0K J 1/16W	
R143		RK73HB1J000J	CHIP R 0.0 J 1/16W		R215		RK73HB1J101J	CHIP R 100 J 1/16W	
R144		RK73HB1J000J	CHIP R 0.0 J 1/16W		R216		RK73HB1J102J	CHIP R 1.0K J 1/16W	
R145		RK73HB1J104J	CHIP R 100K J 1/16W		R217		RK73HB1J102J	CHIP R 1.0K J 1/16W	
R146		RK73HB1J101J	CHIP R 100 J 1/16W		R218		RK73HB1J102J	CHIP R 1.0K J 1/16W	
R147		RK73HB1J101J	CHIP R 100 J 1/16W		R219		RK73HB1J102J	CHIP R 1.0K J 1/16W	
R148		RK73HB1J563J	CHIP R 56K J 1/16W		R220		RK73HB1J471J	CHIP R 470 J 1/16W	
R149		RK73HB1J104J	CHIP R 100K J 1/16W		R221		RK73HB1J102J	CHIP R 1.0K J 1/16W	
R150		RK73HB1J104J	CHIP R 100K J 1/16W		R222		RK73HB1J101J	CHIP R 100 J 1/16W	
R151		RK73HB1J104J	CHIP R 100K J 1/16W		R223		RK73HB1J102J	CHIP R 1.0K J 1/16W	
R152		RK73HB1J102J	CHIP R 1.0K J 1/16W		R224		RK73HB1J121J	CHIP R 120 J 1/16W	
R153		RK73HB1J473J	CHIP R 47K J 1/16W		R225		RK73HB1J102J	CHIP R 1.0K J 1/16W	
R154		RK73HB1J104J	CHIP R 100K J 1/16W		R226		RK73HB1J103J	CHIP R 10K J 1/16W	
R155		RK73HB1J104J	CHIP R 100K J 1/16W		R227		RK73HB1J122J	CHIP R 1.2K J 1/16W	
R156		RK73HB1J474J	CHIP R 470K J 1/16W		R228		RK73HB1J122J	CHIP R 1.2K J 1/16W	
R157		RK73HB1J474J	CHIP R 470K J 1/16W		R229		RK73HB1J122J	CHIP R 1.2K J 1/16W	
R158		RK73HB1J474J	CHIP R 470K J 1/16W		R230		RK73HB1J122J	CHIP R 1.2K J 1/16W	
R159		RK73HB1J103J	CHIP R 10K J 1/16W		R231		RK73HB1J000J	CHIP R 0.0 J 1/16W	
R160		RK73HB1J101J	CHIP R 100 J 1/16W		R232		RK73HB1J000J	CHIP R 0.0 J 1/16W	
R161		RK73HB1J103J	CHIP R 10K J 1/16W		R233		RK73HB1J000J	CHIP R 0.0 J 1/16W	
R162		RK73HB1J104J	CHIP R 100K J 1/16W		R234		RK73HB1J000J	CHIP R 0.0 J 1/16W	
R163		RK73HH1J334D	CHIP R 330K D 1/16W		R235		RK73HB1J000J	CHIP R 0.0 J 1/16W	
R164		RK73HH1J104D	CHIP R 100K D 1/16W		R236		RK73HB1J000J	CHIP R 0.0 J 1/16W	
R165		RK73HB1J104J	CHIP R 100K J 1/16W		R237		RK73HB1J000J	CHIP R 0.0 J 1/16W	
R166		RK73HB1J104J	CHIP R 100K J 1/16W		R238		RK73HB1J000J	CHIP R 0.0 J 1/16W	
R167		RK73HB1J473J	CHIP R 47K J 1/16W		R241		RK73HB1J000J	CHIP R 0.0 J 1/16W	
R168		RK73HB1J473J	CHIP R 47K J 1/16W		R242		RK73HB1J000J	CHIP R 0.0 J 1/16W	
R169		RK73HB1J473J	CHIP R 47K J 1/16W		R243		RK73HB1J000J	CHIP R 0.0 J 1/16W	
R170		RK73HH1J124D	CHIP R 120K D 1/16W		R244		RK73HB1J000J	CHIP R 0.0 J 1/16W	
R171		RK73HB1J473J	CHIP R 47K J 1/16W		R245		RK73HB1J000J	CHIP R 0.0 J 1/16W	
R172		RK73HB1J103J	CHIP R 10K J 1/16W		R246		RK73HB1J000J	CHIP R 0.0 J 1/16W	
R173		RK73HB1J473J	CHIP R 47K J 1/16W		R247		RK73HB1J000J	CHIP R 0.0 J 1/16W	
R174		RK73HB1J473J	CHIP R 47K J 1/16W		R248		RK73HB1J000J	CHIP R 0.0 J 1/16W	
R175		RK73HB1J683J	CHIP R 68K J 1/16W		R249		RK73HB1J000J	CHIP R 0.0 J 1/16W	
R176		RK73HB1J473J	CHIP R 47K J 1/16W		R250		RK73HB1J000J	CHIP R 0.0 J 1/16W	
R177		RK73HB1J473J	CHIP R 47K J 1/16W		R251		RK73HB1J000J	CHIP R 0.0 J 1/16W	
R178		RK73HB1J473J	CHIP R 47K J 1/16W		R252		RK73HB1J000J	CHIP R 0.0 J 1/16W	
R179		RK73HB1J000J	CHIP R 0.0 J 1/16W		R253		RK73HB1J000J	CHIP R 0.0 J 1/16W	
R181		RK73HB1J473J	CHIP R 47K J 1/16W		R254		RK73HB1J103J	CHIP R 10K J 1/16W	
R183		RK73HB1J473J	CHIP R 47K J 1/16W		R255		RK73HB1J000J	CHIP R 0.0 J 1/16W	
R184		RK73HB1J000J	CHIP R 0.0 J 1/16W		R256		RK73HB1J000J	CHIP R 0.0 J 1/16W	
R185		RK73HB1J473J	CHIP R 47K J 1/16W		R257		RK73HB1J000J	CHIP R 0.0 J 1/16W	
R186		RK73HB1J103J	CHIP R 10K J 1/16W		R258		RK73HB1J000J	CHIP R 0.0 J 1/16W	
R187		RK73HB1J473J	CHIP R 47K J 1/16W		R259		RK73HB1J000J	CHIP R 0.0 J 1/16W	
R190		RK73HB1J000J	CHIP R 0.0 J 1/16W		R260		RK73HB1J000J	CHIP R 0.0 J 1/16W	
R191		RK73HB1J474J	CHIP R 470K J 1/16W		R261		RK73HB1J000J	CHIP R 0.0 J 1/16W	
R194		RK73HB1J103J	CHIP R 10K J 1/16W		R262		RK73HB1J000J	CHIP R 0.0 J 1/16W	
R196		RK73HB1J103J	CHIP R 10K J 1/16W		R263		RK73HB1J103J	CHIP R 10K J 1/16W	
R197		RK73HB1J103J	CHIP R 10K J 1/16W		R265		RK73HB1J471J	CHIP R 470 J 1/16W	
R199		RK73HB1J103J	CHIP R 10K J 1/16W		R266		RK73HB1J471J	CHIP R 470 J 1/16W	
R204		RK73HB1J103J	CHIP R 10K J 1/16W		R267		RK73HB1J103J	CHIP R 10K J 1/16W	
R205		RK73HB1J102J	CHIP R 1.0K J 1/16W		R268		RK73HB1J000J	CHIP R 0.0 J 1/16W	
R206		RK73HB1J102J	CHIP R 1.0K J 1/16W		R269		RK73HB1J103J	CHIP R 10K J 1/16W	

PARTS LIST

CONTROL UNIT (X53-4580-10)

Ref. No.	Address	Parts No.	Description	Desti- nation	Ref. No.	Address	Parts No.	Description	Desti- nation
R270		RK73HB1J101J	CHIP R 100 J 1/16W		R425		RK73HB1J223J	CHIP R 22K J 1/16W	
R271		RK73HB1J101J	CHIP R 100 J 1/16W		R426		RK73HB1J103J	CHIP R 10K J 1/16W	
R272		RK73HB1J101J	CHIP R 100 J 1/16W		R430		RK73HB1J2R7J	CHIP R 2.7 J 1/16W	
R273		RK73HB1J101J	CHIP R 100 J 1/16W		R431		RK73HB1J000J	CHIP R 0.0 J 1/16W	
R274		RK73HB1J101J	CHIP R 100 J 1/16W		R432		RK73HB1J333J	CHIP R 33K J 1/16W	
R275		RK73HB1J101J	CHIP R 100 J 1/16W		R433		RK73HB1J104J	CHIP R 100K J 1/16W	
R276		RK73HB1J471J	CHIP R 470 J 1/16W		R435		RK73HB1J473J	CHIP R 47K J 1/16W	
R277		RK73HB1J101J	CHIP R 100 J 1/16W		R436		RK73HB1J124J	CHIP R 120K J 1/16W	
R278		RK73HB1J471J	CHIP R 470 J 1/16W		R437		RK73HB1J333J	CHIP R 33K J 1/16W	
R279		RK73HB1J471J	CHIP R 470 J 1/16W		R438		RK73HB1J104J	CHIP R 100K J 1/16W	
R280		RK73HB1J101J	CHIP R 100 J 1/16W		R439		RK73HB1J473J	CHIP R 47K J 1/16W	
R281		RS14KB3D5R6J	FL-PROOF RS 5.6 J 2W		R441		RK73HB1J104J	CHIP R 100K J 1/16W	
R282		RK73HB1J104J	CHIP R 100K J 1/16W		R442		RK73HB1J683J	CHIP R 68K J 1/16W	
R301		RK73HB1J000J	CHIP R 0.0 J 1/16W		R443		RK73HB1J000J	CHIP R 0.0 J 1/16W	
R302		RK73HB1J000J	CHIP R 0.0 J 1/16W		R444		RK73HB1J333J	CHIP R 33K J 1/16W	
R303		RK73HB1J104J	CHIP R 100K J 1/16W		R445		RK73HB1J333J	CHIP R 33K J 1/16W	
R304		RK73HB1J223J	CHIP R 22K J 1/16W		R446		RK73HB1J224J	CHIP R 220K J 1/16W	
R305		RK73HB1J183J	CHIP R 18K J 1/16W		R450		RK73HB1J473J	CHIP R 47K J 1/16W	
R306		RK73HH1J184D	CHIP R 180K D 1/16W		R451		RK73HB1J104J	CHIP R 100K J 1/16W	
R307		RK73HH1J273D	CHIP R 27K D 1/16W		R452		RK73HB1J473J	CHIP R 47K J 1/16W	
R308		RK73HB1J473J	CHIP R 47K J 1/16W		R457		RK73HB1J000J	CHIP R 0.0 J 1/16W	
R309		RK73PB2H220J	CHIP R 22 J 1/2W		R458		RK73HB1J101J	CHIP R 100 J 1/16W	
R310		RK73GB2A220J	CHIP R 22 J 1/10W		R459		RK73HB1J101J	CHIP R 100 J 1/16W	
R312		RK73HB1J104J	CHIP R 100K J 1/16W		R460		RK73HB1J101J	CHIP R 100 J 1/16W	
R313		RK73HH1J822D	CHIP R 8.2K D 1/16W		R461		RK73HB1J223J	CHIP R 22K J 1/16W	
R314		RK73HH1J332D	CHIP R 3.3K D 1/16W		R462		RK73HB1J223J	CHIP R 22K J 1/16W	
R315		RK73HB1J471J	CHIP R 470 J 1/16W		R463		RK73HB1J223J	CHIP R 22K J 1/16W	
R316		RK73HB1J000J	CHIP R 0.0 J 1/16W		R464		RK73HB1J104J	CHIP R 100K J 1/16W	
R317		RK73HB1J472J	CHIP R 4.7K J 1/16W		R465		RK73HB1J104J	CHIP R 100K J 1/16W	
R318		RK73HB1J472J	CHIP R 4.7K J 1/16W		R466		RK73HB1J000J	CHIP R 0.0 J 1/16W	
R319		RK73HB1J103J	CHIP R 10K J 1/16W		R467		RK73HB1J000J	CHIP R 0.0 J 1/16W	
R320		RK73HB1J101J	CHIP R 100 J 1/16W		R502		RK73HB1J000J	CHIP R 0.0 J 1/16W	
R321		RK73HH1J272D	CHIP R 2.7K D 1/16W		R508		RK73HB1J103J	CHIP R 10K J 1/16W	
R322		RK73HH1J473D	CHIP R 47K D 1/16W		R509		RK73HB1J223J	CHIP R 22K J 1/16W	
R323		RK73HB1J102J	CHIP R 1.0K J 1/16W		R510		RK73HB1J103J	CHIP R 10K J 1/16W	
R324		RK73GB2A000J	CHIP R 0.0 J 1/10W		R511		RK73HB1J000J	CHIP R 0.0 J 1/16W	
R401		RK73HB1J473J	CHIP R 47K J 1/16W		R606		RK73HB1J103J	CHIP R 10K J 1/16W	
R402		RK73HB1J472J	CHIP R 4.7K J 1/16W		R607		RK73HB1J103J	CHIP R 10K J 1/16W	
R403		RK73HB1J473J	CHIP R 47K J 1/16W		R608		RK73HB1J102J	CHIP R 1.0K J 1/16W	
R404		RK73HB1J472J	CHIP R 4.7K J 1/16W		R609		RK73HB1J000J	CHIP R 0.0 J 1/16W	
R405		RK73HB1J473J	CHIP R 47K J 1/16W		R610		RK73HB1J104J	CHIP R 100K J 1/16W	
R406		RK73HB1J104J	CHIP R 100K J 1/16W		R612		RK73HB1J104J	CHIP R 100K J 1/16W	
R407		RK73HB1J104J	CHIP R 100K J 1/16W		R626		RK73HB1J000J	CHIP R 0.0 J 1/16W	
R408		RK73HB1J103J	CHIP R 10K J 1/16W		R627		RK73HB1J102J	CHIP R 1.0K J 1/16W	
R409		RK73HB1J103J	CHIP R 10K J 1/16W		R628		RK73HB1J102J	CHIP R 1.0K J 1/16W	
R410		RK73HB1J104J	CHIP R 100K J 1/16W		R629		RK73HB1J473J	CHIP R 47K J 1/16W	
R411		RK73HB1J472J	CHIP R 4.7K J 1/16W		R630		RK73HB1J473J	CHIP R 47K J 1/16W	
R412		RK73HB1J123J	CHIP R 12K J 1/16W		R634		RK73HB1J000J	CHIP R 0.0 J 1/16W	
R413		RK73HB1J223J	CHIP R 22K J 1/16W		R635		RK73HB1J000J	CHIP R 0.0 J 1/16W	
R414		RK73HB1J153J	CHIP R 15K J 1/16W		R636		RK73HB1J000J	CHIP R 0.0 J 1/16W	
R415		RK73HB1J123J	CHIP R 12K J 1/16W		R637		RK73HB1J000J	CHIP R 0.0 J 1/16W	
R416		RK73HB1J224J	CHIP R 220K J 1/16W		R638		RK73HB1J000J	CHIP R 0.0 J 1/16W	
R417		RK73HB1J104J	CHIP R 100K J 1/16W		R639		RK73HB1J000J	CHIP R 0.0 J 1/16W	
R418		RK73HB1J104J	CHIP R 100K J 1/16W		R640		RK73HB1J104J	CHIP R 100K J 1/16W	
R419		RK73HB1J105J	CHIP R 1.0M J 1/16W		R641		RK73HB1J103J	CHIP R 10K J 1/16W	
R420		RK73HB1J000J	CHIP R 0.0 J 1/16W		R648		RK73GB2A000J	CHIP R 0.0 J 1/10W	
R421		RK73HB1J393J	CHIP R 39K J 1/16W		R649		RK73GB2A000J	CHIP R 0.0 J 1/10W	
R422		RK73HB1J223J	CHIP R 22K J 1/16W		R656		RK73HB1J000J	CHIP R 0.0 J 1/16W	
R423		RK73HB1J471J	CHIP R 470 J 1/16W		R657		RK73HB1J000J	CHIP R 0.0 J 1/16W	
R424		RK73HB1J153J	CHIP R 15K J 1/16W		R658		RK73HB1J000J	CHIP R 0.0 J 1/16W	

PARTS LIST

CONTROL UNIT (X53-4580-10)
DISPLAY UNIT (X54-4060-20)

Ref. No.	Address	Parts No.	Description	Desti- nation	Ref. No.	Address	Parts No.	Description	Desti- nation
R659		RK73HB1J103J	CHIP R 10K J 1/16W		D502		HSM88AS-E	DIODE	
R662		RK73HB1J000J	CHIP R 0.0 J 1/16W		D503		B30-2151-05	LED (RED/GREEN)	
R664		RK73HB1J000J	CHIP R 0.0 J 1/16W		D504		B30-2151-05	LED (RED/GREEN)	
R665		RK73HB1J104J	CHIP R 100K J 1/16W		D505		B30-2151-05	LED (RED/GREEN)	
R666		RK73GB2A000J	CHIP R 0.0 J 1/10W		D506		LA-501DD	LED	
R667		RK73GB2A000J	CHIP R 0.0 J 1/10W		D507		LA-501DD	LED	
TH1		ERTJ0V104H	NEGATIVE TEMP THERMISTOR		D508		DA204U	MULTIPLE DIODE	
X1		L77-3015-05	TCXO (18.432MHZ)		D509		DA204U	MULTIPLE DIODE	
X2		L77-1802-05	CRYSTAL RESONATOR (32768HZ)		D510		DA204U	MULTIPLE DIODE	
					D511		DA204U	MULTIPLE DIODE	
					D512		DA204U	MULTIPLE DIODE	
					D513		DA204U	MULTIPLE DIODE	
					D514		DA204U	MULTIPLE DIODE	
					D601		DA204U	MULTIPLE DIODE	
					D602		DA204U	MULTIPLE DIODE	
DISPLAY UNIT (X54-4060-20)									
-		J31-0543-05	COLLAR (LH-5-1.5)		D603		MINISMD020F	VARISTOR	
C501		CS77BA1A100M	CHIP TNL 10UF 10WV		IC501		NJM4558E-ZB	BIPOLAR IC	
C502		CS77MA1D1R5M	CHIP TNL 1.5UF 20WV		IC502		BU4094BCFV	MOS-IC	
C503		CS77MA1D1R5M	CHIP TNL 1.5UF 20WV		IC503		BU4094BCFV	MOS-IC	
C504		CK73GBB1C104K	CHIP C 0.1UF K		IC504		BU4094BCFV	MOS-IC	
C505		CK73GBB1C104K	CHIP C 0.1UF K		IC505		BU4094BCFV	MOS-IC	
C506		CC73GCH1H470J	CHIP C 47PF J		IC506		TA78L05FF	BIPOLAR IC	
C507		CK73GBB1C104K	CHIP C 0.1UF K		IC507		TA78L05FF	BIPOLAR IC	
C508		CK73GBB1C104K	CHIP C 0.1UF K		IC508		TC7W53FU-F	HYBRID IC	
C509		CK73GBB1H103K	CHIP C 0.01UF K		J601		E58-0558-05	MODULAR JACK	
C510		CS77BA1A100M	CHIP TNL 10UF 10WV		Q501		2SC4116(Y)F	TRANSISTOR	
C511		CK73GB1E103K	CHIP C 0.01UF K		Q502		2SA1586(Y,GR)F	TRANSISTOR	
C512		CK73GB1E103K	CHIP C 0.01UF K		Q503		UPA672T-A	FET	
C513		CC73GCH1H101J	CHIP C 100PF J		Q504		UPA672T-A	FET	
C514		CC73GCH1H101J	CHIP C 100PF J		Q506		LTA014EUBFS8	DIGITAL TRANSISTOR	
C515		CC73GCH1H101J	CHIP C 100PF J		Q507		UPA672T-A	FET	
C516		CC73GCH1H101J	CHIP C 100PF J		Q508		LTA014EUBFS8	DIGITAL TRANSISTOR	
C517		CC73GCH1H101J	CHIP C 100PF J		Q509		LTA014EUBFS8	DIGITAL TRANSISTOR	
C518		CC73GCH1H101J	CHIP C 100PF J		Q510		LTA014EUBFS8	DIGITAL TRANSISTOR	
C519		CK73GB1E103K	CHIP C 0.01UF K		Q511		LTA014EUBFS8	DIGITAL TRANSISTOR	
C520		CK73GB1E103K	CHIP C 0.01UF K		Q512		UPA672T-A	FET	
C521		CS77BA1A100M	CHIP TNL 10UF 10WV		Q513		UPA672T-A	FET	
C522		CK73GBB1C104K	CHIP C 0.1UF K		Q514		UPA672T-A	FET	
C523		CK73FB1E334K	CHIP C 0.33UF K		Q516		UPA672T-A	FET	
C524		CS77BA1A100M	CHIP TNL 10UF 10WV		Q517		UPA672T-A	FET	
C525		CK73GBB1C104K	CHIP C 0.1UF K		Q518		UPA672T-A	FET	
C526		CK73FB1E334K	CHIP C 0.33UF K		Q519		UPA672T-A	FET	
C527		CK73GBB1H102K	CHIP C 1000PF K		Q521		UPA672T-A	FET	
C528		CK73GBB1H103K	CHIP C 0.01UF K		Q522		UPA672T-A	FET	
C532		CK73GBB1H102K	CHIP C 1000PF K		Q523		UPA672T-A	FET	
C533		CC73GCH1H101J	CHIP C 100PF J		Q524		UPA672T-A	FET	
C534		CK73GBB1H102K	CHIP C 1000PF K		Q525		2SK1824-A	FET	
C601		CC73GCH1H101J	CHIP C 100PF J		R502		RK73GB2A000J	CHIP R 0.0 J 1/10W	
C602		CK73GBB1H102K	CHIP C 1000PF K		R503		RK73GB2A000J	CHIP R 0.0 J 1/10W	
C603		CC73GCH1H101J	CHIP C 100PF J		R505		RK73GB2A683J	CHIP R 68K J 1/10W	
C606		CC73GCH1H101J	CHIP C 100PF J		R506		RK73GB2A103J	CHIP R 10K J 1/10W	
C607		CK73GBB1C104K	CHIP C 0.1UF K		R507		RK73GB2A682J	CHIP R 6.8K J 1/10W	
CN501		E41-2743-05	PIN ASSY		R508		RK73GB2A102J	CHIP R 1.0K J 1/10W	
CN502		E40-6102-05	PIN ASSY		R509		RK73GB2A103J	CHIP R 10K J 1/10W	
CN601		E41-2751-05	PIN ASSY		R510		RK73GB2A224J	CHIP R 220K J 1/10W	
CP51		RK75GB1J471J	CHIP-COM 470 J 1/16W		R511		RK73GB2A103J	CHIP R 10K J 1/10W	
CP52		RK75GB1J471J	CHIP-COM 470 J 1/16W		R512		RK73GB2A103J	CHIP R 10K J 1/10W	
CP53		RK75GB1J471J	CHIP-COM 470 J 1/16W		R513		RK73GB2A104J	CHIP R 100K J 1/10W	
CP54		RK75GB1J471J	CHIP-COM 470 J 1/16W		R514		RK73GB2A154J	CHIP R 150K J 1/10W	
D501		HSM88AS-E	DIODE		R516		RK73PB2H102J	CHIP R 1.0K J 1/2W	

TKR-D810

PARTS LIST

DISPLAY UNIT (X54-4060-20)

TX-RX UNIT (X57-897K-XX)

Ref. No.	Address	Parts No.	Description	Desti- nation	Ref. No.	Address	Parts No.	Description	Desti- nation
R517		RK73PB2H821J	CHIP R 820 J 1/2W		C108		CC73HCH1H120G	CHIP C 12PF G	K2
R518		RK73PB2H102J	CHIP R 1.0K J 1/2W		C109		CK73HBB1H471K	CHIP C 470PF K	
R519		RK73PB2H102J	CHIP R 1.0K J 1/2W		C110		CS77MA1V2R2M	CHIP TNTL 2.2UF 35WV	
R520		RK73PB2H821J	CHIP R 820 J 1/2W		C111		CC73HCH1H050B	CHIP C 5.0PF B	K
R521		RK73PB2H821J	CHIP R 820 J 1/2W		C111		CC73HCH1H090B	CHIP C 9.0PF B	K2
R522		RK73PB2H821J	CHIP R 820 J 1/2W		C112		CC73HCH1H100B	CHIP C 10PF B	K
R523		RK73PB2H821J	CHIP R 820 J 1/2W		C112		CC73HCH1H180G	CHIP C 18PF G	K2
R524		RK73PB2H821J	CHIP R 820 J 1/2W		C113		CC73HCH1H080B	CHIP C 8.0PF B	K
R525		RK73PB2H821J	CHIP R 820 J 1/2W		C113		CC73HCH1H100B	CHIP C 10PF B	K2
R526		RK73PB2H821J	CHIP R 820 J 1/2W		C114		CK73HBB1H471K	CHIP C 470PF K	
R529		RK73GB2A102J	CHIP R 1.0K J 1/10W		C115		CC73HCH1H050B	CHIP C 5.0PF B	K
R530		RK73GB2A102J	CHIP R 1.0K J 1/10W		C115		CC73HCH1H090B	CHIP C 9.0PF B	K2
R531		RK73GB2A102J	CHIP R 1.0K J 1/10W		C116		CK73HBB1H471K	CHIP C 470PF K	
R532		RK73GB2A102J	CHIP R 1.0K J 1/10W		C117		CC73HCH1H020B	CHIP C 2.0PF B	K
R533		RK73GB2A102J	CHIP R 1.0K J 1/10W		C117		CC73HCH1H050B	CHIP C 5.0PF B	K2
R534		RK73GB2A102J	CHIP R 1.0K J 1/10W		C118		CC73HCH1H120G	CHIP C 12PF G	
R535		RK73GB2A102J	CHIP R 1.0K J 1/10W		C119		CK73HB1E104K	CHIP C 0.10UF K	
R536		RK73GB2A102J	CHIP R 1.0K J 1/10W		C120		CK73HBB1H471K	CHIP C 470PF K	
R537		RK73GB2A102J	CHIP R 1.0K J 1/10W		C121		CC73HCH1H030B	CHIP C 3.0PF B	K
R538		RK73GB2A102J	CHIP R 1.0K J 1/10W		C121		CC73HCH1H060B	CHIP C 6.0PF B	K2
R539		RK73GB2A102J	CHIP R 1.0K J 1/10W		C122		CK73HBB1H471K	CHIP C 470PF K	
R540		RK73GB2A102J	CHIP R 1.0K J 1/10W		C123		CK73HB1E104K	CHIP C 0.10UF K	K2
R541		RK73GB2A103J	CHIP R 10K J 1/10W		C123		CK73HBB1H471K	CHIP C 470PF K	K
R542		RK73GB2A103J	CHIP R 10K J 1/10W		C124		CC73HCH1H080B	CHIP C 8.0PF B	
R543		RK73GB2A103J	CHIP R 10K J 1/10W		C125		CK73HBB1H471K	CHIP C 470PF K	
R544		RK73GB2A103J	CHIP R 10K J 1/10W		C126		CK73HB1E104K	CHIP C 0.10UF K	
R545		RK73GH2A472D	CHIP R 4.7K D 1/10W		C127		CK73HBB1H471K	CHIP C 470PF K	
R546		RK73GH2A153D	CHIP R 15K D 1/10W		C129		CC73HCH1H080B	CHIP C 8.0PF B	
R547		RK73GB2A103J	CHIP R 10K J 1/10W		C130		CC73HCH1H100B	CHIP C 10PF B	
R550		RK73GB2A472J	CHIP R 4.7K J 1/10W		C131		CK73HB1E104K	CHIP C 0.10UF K	
R601		RK73GB2A681J	CHIP R 680 J 1/10W		C134		CK73HBB1H471K	CHIP C 470PF K	
R604		RK73GB2A102J	CHIP R 1.0K J 1/10W		C135		CC73HCH1H030B	CHIP C 3.0PF B	K
R605		RK73GB2A102J	CHIP R 1.0K J 1/10W		C135		CC73HCH1H050B	CHIP C 5.0PF B	K2
R606		RK73GB2A473J	CHIP R 47K J 1/10W		C136		CC73HCH1H100B	CHIP C 10PF B	K
S501		S70-0502-05	TACT SWITCH		C136		CC73HCH1H120G	CHIP C 12PF G	K2
S502		S70-0502-05	TACT SWITCH		C137		CK73HBB1H471K	CHIP C 470PF K	
S503		S70-0502-05	TACT SWITCH		C138		CC73HCH1H070B	CHIP C 7.0PF B	K
S504		S70-0502-05	TACT SWITCH		C138		CC73HCH1H090B	CHIP C 9.0PF B	K2
S505		S70-0502-05	TACT SWITCH		C139		CK73HBB1H471K	CHIP C 470PF K	
S506		S70-0502-05	TACT SWITCH		C140		CC73HCH1H100B	CHIP C 10PF B	K
S507		S68-0430-05	PUSH SWITCH		C140		CC73HCH1H180G	CHIP C 18PF G	K2
VR501		R32-0689-05	SEMI FIXED VARIABLE RESISTOR(10K)		C141		CC73HCH1H080B	CHIP C 8.0PF B	K
VR601		R31-0630-05	VARIABLE RESISTOR (10K)		C141		CC73HCH1H100B	CHIP C 10PF B	K2
TX-RX UNIT (X57-897K-XX) -02:K -03:K2					C142		CK73HBB1H471K	CHIP C 470PF K	
-		F10-2409-14	SHIELDING CASE		C143		CC73HCH1H070B	CHIP C 7.0PF B	K
C100		CC73HCH1H050B	CHIP C 5.0PF B		C143		CC73HCH1H090B	CHIP C 9.0PF B	K2
C101		CC73HCH1H150G	CHIP C 15PF G	K	C144		CC73HCH1H100C	CHIP C 10PF C	K2
C101		CC73HCH1H560J	CHIP C 56PF J	K2	C144		CC73HCH1H120G	CHIP C 12PF G	K
C102		CC73HCH1H010B	CHIP C 1.0PF B	K	C145		CC73HCH1H080B	CHIP C 8.0PF B	K
C102		CC73HCH1H060B	CHIP C 6.0PF B	K2	C145		CC73HCH1H120G	CHIP C 12PF G	K2
C103		CC73HCH1H120G	CHIP C 12PF G	K	C146		CK73HBB1H471K	CHIP C 470PF K	
C103		CC73HCH1H150G	CHIP C 15PF G	K2	C147		CC73HCH1H070B	CHIP C 7.0PF B	K
C104		CK73HBB1H471K	CHIP C 470PF K		C147		CC73HCH1H090B	CHIP C 9.0PF B	K2
C105		CC73HCH1H050B	CHIP C 5.0PF B	K	C148		CK73HBB1H471K	CHIP C 470PF K	
C105		CC73HCH1H090B	CHIP C 9.0PF B	K2	C149		CC73HCH1H040B	CHIP C 4.0PF B	
C106		CK73HBB1H471K	CHIP C 470PF K		C150		CC73HCH1H090B	CHIP C 9.0PF B	K
C107		CC73HCH1H090B	CHIP C 9.0PF B	K	C150		CC73HCH1H150G	CHIP C 15PF G	K2
C107		CC73HCH1H120G	CHIP C 12PF G	K2	C151		CC73HCH1H050B	CHIP C 5.0PF B	K2
C108		CC73HCH1H080B	CHIP C 8.0PF B	K	C151		CC73HCH1H060B	CHIP C 6.0PF B	K
					C152		CC73HCH1H050B	CHIP C 5.0PF B	

PARTS LIST

TX-RX UNIT (X57-897K-XX)

Ref. No.	Address	Parts No.	Description	Desti- nation	Ref. No.	Address	Parts No.	Description	Desti- nation
C154		CC73HCH1H050B	CHIP C 5.0PF B		C222		CK73HB1H103K	CHIP C 10000PF K	
C155		CC73HCH1H010B	CHIP C 1.0PF B		C223		CK73HB1H103K	CHIP C 10000PF K	
C156		CC73HCH1H050B	CHIP C 5.0PF B		C224		CK73HBB1H471K	CHIP C 470PF K	
C157		CC73HCH1H560J	CHIP C 56PF J		C225		CC73HCH1H100D	CHIP C 10PF D	
C158		CC73HCH1H050B	CHIP C 5.0PF B	K	C226		CC73HCH1H680J	CHIP C 68PF J	
C158		CC73HCH1H080B	CHIP C 8.0PF B	K2	C227		CK73HB1E104K	CHIP C 0.10UF K	
C159		CC73HCH1H060B	CHIP C 6.0PF B		C228		CC73HCH1H101J	CHIP C 100PF J	
C160		CK73HBB1H471K	CHIP C 470PF K		C229		CK73HBB1H471K	CHIP C 470PF K	
C161		CC73HCH1H150G	CHIP C 15PF G	K	C230		CC73HCH1H680J	CHIP C 68PF J	
C161		CK73HB1H561K	CHIP C 560PF K	K2	C231		CK73HBB1H471K	CHIP C 470PF K	
C162		CC73HCH1H050B	CHIP C 5.0PF B	K2	C232		CC73HCH1H020B	CHIP C 2.0PF B	K
C162		CC73HCH1H3R5B	CHIP C 3.5PF B	K	C233		CC73HCH1H330J	CHIP C 33PF J	K
C163		CC73HCH1H030B	CHIP C 3.0PF B	K	C233		CC73HCH1H470J	CHIP C 47PF J	K2
C163		CC73HCH1H050B	CHIP C 5.0PF B	K2	C234		CC73HCH1H330J	CHIP C 33PF J	K
C164		CC73HCH1H030B	CHIP C 3.0PF B	K	C234		CC73HCH1H470J	CHIP C 47PF J	K2
C164		CC73HCH1H060B	CHIP C 6.0PF B	K2	C235		CK73HBB1H471K	CHIP C 470PF K	
C165		CC73HCH1H050B	CHIP C 5.0PF B	K2	C236		CK73HBB1H471K	CHIP C 470PF K	
C165		CC73HCH1H3R5B	CHIP C 3.5PF B	K	C237		CC73HCH1H080B	CHIP C 8.0PF B	K2
C166		CC73HCH1H050B	CHIP C 5.0PF B		C237		CC73HCH1H100B	CHIP C 10PF B	K
C167		CC73HCH1H050B	CHIP C 5.0PF B	K	C239		CC73HCH1H070B	CHIP C 7.0PF B	K
C167		CC73HCH1H060B	CHIP C 6.0PF B	K2	C240		CK73HBB1H471K	CHIP C 470PF K	K2
C168		CC73HCH1H050B	CHIP C 5.0PF B	K	C241		CC73HCH1H080B	CHIP C 8.0PF B	K2
C168		CC73HCH1H060B	CHIP C 6.0PF B	K2	C241		CC73HCH1H120J	CHIP C 12PF J	K
C169		CC73HCH1H050B	CHIP C 5.0PF B	K	C242		CC73HCH1H020B	CHIP C 2.0PF B	K2
C169		CC73HCH1H060B	CHIP C 6.0PF B	K2	C243		CC73HCH1H120J	CHIP C 12PF J	
C170		CC73HCH1H220G	CHIP C 22PF G	K	C244		CC73HCH1H010B	CHIP C 1.0PF B	K2
C170		CC73HCH1H560J	CHIP C 56PF J	K2	C245		CC73HCH1H060D	CHIP C 6.0PF D	
C171		CC73HCH1H040B	CHIP C 4.0PF B	K	C246		CK73HB1H103K	CHIP C 10000PF K	
C171		CC73HCH1H060B	CHIP C 6.0PF B	K2	C247		CK73HBB1H471K	CHIP C 470PF K	
C172		CC73HCH1H060B	CHIP C 6.0PF B	K2	C248		CK73HBB1H471K	CHIP C 470PF K	K
C172		CC73HCH1H070B	CHIP C 7.0PF B	K	C249		CC73HCH1H101J	CHIP C 100PF J	K
C173		CC73HCH1H030B	CHIP C 3.0PF B	K2	C300		CC73HCH1H270J	CHIP C 27PF J	
C173		CC73HCH1H3R5B	CHIP C 3.5PF B	K	C301		CK73HBB1H471K	CHIP C 470PF K	
C174		CC73HCH1H040B	CHIP C 4.0PF B	K2	C302		CK73HB1H103K	CHIP C 10000PF K	
C174		CC73HCH1H1R5B	CHIP C 1.5PF B	K	C303		CK73HB1H103K	CHIP C 10000PF K	
C175		CC73HCH1H050B	CHIP C 5.0PF B	K2	C304		CK73HB1H103K	CHIP C 10000PF K	
C175		CC73HCH1H1R5B	CHIP C 1.5PF D	K	C305		CK73HB1H103K	CHIP C 10000PF K	
C176		CK73GB1H471K	CHIP C 470PF K		C306		CC73HCH1H020B	CHIP C 2.0PF B	
C200		CS77MA1V2R2M	CHIP TNL 2.2UF 5WV		C318		CC73HCH1H270G	CHIP C 27PF G	
C201		CS77MA1V2R2M	CHIP TNL 2.2UF 35WV		C322		CK73HBB1H471K	CHIP C 470PF K	
C202		CC73HCH1H100D	CHIP C 10PF D		C323		CE32CL1E4R7M	CHIP EL 4.7UF 25WV	
C203		CK73HBB1H471K	CHIP C 470PF K		C325		CK73HB1E104K	CHIP C 0.10UF K	
C204		CC73HCH1H101J	CHIP C 100PF J		C326		CC73HCH1H220G	CHIP C 22PF G	K
C205		CK73HB1E104K	CHIP C 0.10UF K		C326		CC73HCH1H330G	CHIP C 33PF G	K2
C206		CC73HCH1H470J	CHIP C 47PF J		C328		CC73HCH1H010B	CHIP C 1.0PF B	K
C207		CS77ABE1D100M	CHIP C 10UF M		C328		CC73HCH1H020B	CHIP C 2.0PF B	K2
C208		CS77ABE1D100M	CHIP C 10UF M		C329		CK73HB1H103K	CHIP C 10000PF K	
C209		CK73HBB1H471K	CHIP C 470PF K		C331		CK73HBB1H471K	CHIP C 470PF K	
C210		CE32CL1V100M	CHIP EL 10UF 35WV		C332		CC73HCH1H150J	CHIP C 15PF J	
C211		CK73HBB1H471K	CHIP C 470PF K		C333		CC73HCH1H090B	CHIP C 9.0PF B	K
C212		CK73HB1H103K	CHIP C 10000PF K		C333		CC73HCH1H120J	CHIP C 12PF J	K2
C213		CC73HCH1H080B	CHIP C 8.0PF B	K	C334		CK73HB1H103K	CHIP C 10000PF K	K,K2
C213		CC73HCH1H100B	CHIP C 10PF B	K2	C335		CC73HCH1H820J	CHIP C 82PF J	
C214		CC73HCH1H030B	CHIP C 3.0PF B	K	C336		CC73HCH1H270J	CHIP C 27PF J	
C214		CC73HCH1H050B	CHIP C 5.0PF B	K2	C337		CK73HB1H103K	CHIP C 10000PF K	
C216		CC73HCH1H030B	CHIP C 3.0PF B	K	C338		CK73HB1H103K	CHIP C 10000PF K	
C216		CC73HCH1H050B	CHIP C 5.0PF B	K2	C339		CC73HCH1H471J	CHIP C 470PF J	
C219		CC73HCH1H100D	CHIP C 10PF D		C341		CK73HB1H103K	CHIP C 10000PF K	
C220		CK73HB1H103K	CHIP C 10000PF K		C342		CC73HCH1H180J	CHIP C 18PF J	
C221		CK73HB1H103K	CHIP C 10000PF K		C343		CK73HB1H103K	CHIP C 10000PF K	

PARTS LIST

TX-RX UNIT (X57-897K-XX)

Ref. No.	Address	Parts No.	Description	Desti- nation	Ref. No.	Address	Parts No.	Description	Desti- nation
C344		CK73HB1H103K	CHIP C 10000PF K		C512		CK73HB1E104K	CHIP C 0.10UF K	
C345		CK73HBB1H471K	CHIP C 470PF K		C514		CK73HB1H103K	CHIP C 10000PF K	
C346		CC73HCH1H180J	CHIP C 18PF J	K2	C515		CK73HB1E104K	CHIP C 0.10UF K	
C346		CC73HCH1H220J	CHIP C 22PF J	K	C517		CK73HB1H103K	CHIP C 10000PF K	
C347		CC73HCH1H150G	CHIP C 15PF G		C518		CK73HB1E104K	CHIP C 0.10UF K	
C349		CK73HB1H103K	CHIP C 10000PF K		C519		CK73HB1H103K	CHIP C 10000PF K	
C350		CK73HB1E104K	CHIP C 0.10UF K		C520		CK73HB1E104K	CHIP C 0.10UF K	
C352		CC73HCH1H080B	CHIP C 8.0PF B	K	C521		CC73HCH1H180J	CHIP C 18PF J	
C352		CC73HCH1H100D	CHIP C 10PF D	K2	C522		CC73HCH1H101J	CHIP C 100PF J	
C353		CC73HCH1H070B	CHIP C 7.0PF B	K	C523		CC73HCH1H331J	CHIP C 330PF J	
C353		CC73HCH1H180J	CHIP C 18PF J	K2	C524		CC73HCH1H180J	CHIP C 18PF J	
C354		CC73HCH1H070B	CHIP C 7.0PF B	K	C525		CC73HCH1H470J	CHIP C 47PF J	
C354		CC73HCH1H090B	CHIP C 9.0PF B	K2	C526		CC73HCH1H471J	CHIP C 470PF J	
C355		CC73HCH1H060B	CHIP C 6.0PF B	K	C528		CC73HCH1H121J	CHIP C 120PF J	
C356		CC73HCH1H100D	CHIP C 10PF D		C529		CC73HCH1H221J	CHIP C 220PF J	
C358		CC73HCH1H100D	CHIP C 10PF D	K2	C530		CK73HB1E104K	CHIP C 0.10UF K	
C358		CC73HCH1H120G	CHIP C 12PF G	K	C531		CK73HB1E104K	CHIP C 0.10UF K	
C400		CK73HB1E104K	CHIP C 0.10UF K		C532		CK73HB1E104K	CHIP C 0.10UF K	
C401		CK73HB1E104K	CHIP C 0.10UF K		C533		CK73HB1E104K	CHIP C 0.10UF K	
C403		CK73HB1E104K	CHIP C 0.10UF K		C534		CC73HCH1H050C	CHIP C 5.0PF C	
C404		CC73HCH1H100D	CHIP C 10PF D		C535		CK73HB1H103K	CHIP C 10000PF K	
C405		CK73HB1E104K	CHIP C 0.10UF K		C536		CK73HB1E104K	CHIP C 0.10UF K	
C407		CK73HBB1H471K	CHIP C 470PF K		C537		CK73HB1E104K	CHIP C 0.10UF K	
C408		CK73HB1E104K	CHIP C 0.10UF K		C538		CK73HB1H103K	CHIP C 10000PF K	
C410		CK73HBB1H471K	CHIP C 470PF K		C539		CC73HCH1H820J	CHIP C 82PF J	
C411		CK73GB1E105K	CHIP C 1.0UF K		C540		CK73HB1H103K	CHIP C 10000PF K	
C412		CK73HBB1H471K	CHIP C 470PF K		C541		CK73HB1E104K	CHIP C 0.10UF K	
C413		CK73GB1E105K	CHIP C 1.0UF K		C542		CK73FB1A106K	CHIP C 10UF K	
C414		CK73HBB1H471K	CHIP C 470PF K		C543		CK73HB1E104K	CHIP C 0.10UF K	
C415		CK73HB1E104K	CHIP C 0.10UF K		C544		CK73HB1E104K	CHIP C 0.10UF K	
C416		CK73HB1H103K	CHIP C 10000PF K		C545		CK73HB1E104K	CHIP C 0.10UF K	
C417		CK73HB1E104K	CHIP C 0.10UF K		C546		CC73HCH1H390J	CHIP C 39PF J	
C418		CK73HBB1H102K	CHIP C 1000PF K		C547		CC73HCH1H100D	CHIP C 10PF D	
C419		CK73HBB1H471K	CHIP C 470PF K		C548		CC73HCH1H100D	CHIP C 10PF D	
C421		CK73HBB1H102K	CHIP C 1000PF K		C549		CK73HB1E104K	CHIP C 0.10UF K	
C422		CK73HB1E104K	CHIP C 0.10UF K		C550		CK73HB1H103K	CHIP C 10000PF K	
C423		CK73HB1H103K	CHIP C 10000PF K		C551		CC73HCH1H100D	CHIP C 10PF D	K
C424		CK73HB1E104K	CHIP C 0.10UF K		C600		CK73FB1A106K	CHIP C 10UF K	
C425		CK73HB1E104K	CHIP C 0.10UF K		C601		CK73FB1A106K	CHIP C 10UF K	
C426		CK73HB1E104K	CHIP C 0.10UF K		C602		CK73HB1E104K	CHIP C 0.10UF K	
C427		CK73HB1E104K	CHIP C 0.10UF K		C603		CK73HB1E104K	CHIP C 0.10UF K	
C428		CK73HB1E104K	CHIP C 0.10UF K		C604		CK73HB1E104K	CHIP C 0.10UF K	
C429		CK73HB1E104K	CHIP C 0.10UF K		C605		CK73HB1H103K	CHIP C 10000PF K	
C430		CK73HB1E104K	CHIP C 0.10UF K		C606		CK73FB1A106K	CHIP C 10UF K	
C437		CK73HB1E104K	CHIP C 0.10UF K		C607		CK73FB1A106K	CHIP C 10UF K	
C438		CK73HB1E104K	CHIP C 0.10UF K		C608		CK73HB1H103K	CHIP C 10000PF K	
C439		CK73HB1E104K	CHIP C 0.10UF K		C610		CK73HB1H103K	CHIP C 10000PF K	
C440		CK73HB1E104K	CHIP C 0.10UF K		C611		CK73HB1H103K	CHIP C 10000PF K	
C500		CK73HB1E104K	CHIP C 0.10UF K		C612		CK73HB1H103K	CHIP C 10000PF K	
C501		CK73HB1E104K	CHIP C 0.10UF K		C613		CK73HB1H103K	CHIP C 10000PF K	
C502		CK73HB1E104K	CHIP C 0.10UF K		C614		CS77ABE1D100M	CHIP C 10UF M	
C503		CK73HB1E104K	CHIP C 0.10UF K		C615		CC73HCH1H181J	CHIP C 180PF J	
C504		CK73HBB1H471K	CHIP C 470PF K		C616		CC73HCH1H470J	CHIP C 47PF J	
C505		CK73HB1E104K	CHIP C 0.10UF K		C618		CS77BB21A470M	CHIP TNL 47UF 10WV	
C506		CK73HB1E104K	CHIP C 0.10UF K		C619		CC73HCH1H331J	CHIP C 330PF J	
C507		CK73HB1E104K	CHIP C 0.10UF K		C620		CC73HCH1H180J	CHIP C 18PF J	
C508		CK73HB1H103K	CHIP C 10000PF K		C621		CS77BB21A470M	CHIP TNL 47UF 10WV	
C509		CK73HB1E104K	CHIP C 0.10UF K		C622		CC73HCH1H221J	CHIP C 220PF J	
C510		CK73HB1E104K	CHIP C 0.10UF K		C623		CK73HB1H103K	CHIP C 10000PF K	
C511		CK73HB1E104K	CHIP C 0.10UF K		C624		CK73HB1E104K	CHIP C 0.10UF K	

PARTS LIST

TX-RX UNIT (X57-897K-XX)

Ref. No.	Address	Parts No.	Description	Desti- nation	Ref. No.	Address	Parts No.	Description	Desti- nation
C625		CK73HB1H103K	CHIP C 10000PF K		C702		CK73GB1E105K	CHIP C 1.0UF K	
C626		CS77ABE1D100M	CHIP C 10UF M		C703		CK73HBB1H471K	CHIP C 470PF K	
C627		CK73HB1H103K	CHIP C 10000PF K		C704		CK73GB1E105K	CHIP C 1.0UF K	
C628		CC73HCH1H100D	CHIP C 10PF D		C705		CK73HBB1H471K	CHIP C 470PF K	
C629		CK73HB1H103K	CHIP C 10000PF K		C706		C92-0765-05	CHIP TNL 4.7UF 16WV	
C630		CK73HB1H103K	CHIP C 10000PF K		C707		CE32CL1V100M	CHIP EL 10UF 35WV	
C631		CC73HCH1H100D	CHIP C 10PF D		C708		CK73HB1E104K	CHIP C 0.10UF K	
C632		CK73HB1E104K	CHIP C 0.10UF K		C709		CK73HB1H103K	CHIP C 10000PF K	
C633		CK73HB1H103K	CHIP C 10000PF K		C710		CK73HBB1H471K	CHIP C 470PF K	
C634		CK73HB1H103K	CHIP C 10000PF K		C711		CK73HBB1H471K	CHIP C 470PF K	
C635		CC73HCH1H100D	CHIP C 10PF D		C712		CK73GB1E105K	CHIP C 1.0UF K	
C636		CK73HB1H103K	CHIP C 10000PF K		C713		CK73HBB1H471K	CHIP C 470PF K	
C637		CK73HB1H103K	CHIP C 10000PF K		C714		CC73HCH1H181J	CHIP C 180PF J	
C638		CK73GB1E105K	CHIP C 1.0UF K		C715		CK73HBB1H471K	CHIP C 470PF K	
C639		CK73HB1H103K	CHIP C 10000PF K		C716		CE32CL1V100M	CHIP EL 10UF 35WV	
C641		CK73HB1H103K	CHIP C 10000PF K		C717		CC73HCH1H220J	CHIP C 22PF J	
C642		CK73HB1E104K	CHIP C 0.10UF K		C718		CK73HBB1H471K	CHIP C 470PF K	
C643		CS77ABE1D100M	CHIP C 10UF M		C719		CK73GB1E105K	CHIP C 1.0UF K	
C644		CC73HCH1H100D	CHIP C 10PF D		C720		CK73HB1E104K	CHIP C 0.10UF K	
C645		CK73GB1E105K	CHIP C 1.0UF K		C721		CK73GB1E105K	CHIP C 1.0UF K	
C647		CS77MA1V2R2M	CHIP TNL 2.2UF 35WV		C722		CK73HB1E104K	CHIP C 0.10UF K	
C648		CS77MA1V2R2M	CHIP TNL 2.2UF 35WV		C723		CK73HB1E104K	CHIP C 0.10UF K	
C649		CK73HB1E104K	CHIP C 0.10UF K		C724		CK73GB1E105K	CHIP C 1.0UF K	
C650		CK73HBB1H471K	CHIP C 470PF K		C725		CK73GB1E105K	CHIP C 1.0UF K	
C651		CC73HCH1H101J	CHIP C 100PF J		C726		CK73HB1H103K	CHIP C 10000PF K	
C652		CC73HCH1H100D	CHIP C 10PF D		C727		CK73GB1E105K	CHIP C 1.0UF K	
C653		CS77ABE1D100M	CHIP C 10UF M		C728		CK73HBB1H471K	CHIP C 470PF K	
C654		CS77ABE1D100M	CHIP C 10UF M		C729		CK73HBB1H471K	CHIP C 470PF K	
C655		CK73HBB1H471K	CHIP C 470PF K		C814		CC73HCH1H101J	CHIP C 100PF J	
C656		CE32CL1V100M	CHIP EL 10UF 35WV		C815		CK73HB1H103K	CHIP C 10000PF K	
C657		CC73HCH1H330J	CHIP C 33PF J		C817		CK73HB1E104K	CHIP C 0.10UF K	
C658		CK73HBB1H471K	CHIP C 470PF K		C818		CK73HB1E104K	CHIP C 0.10UF K	
C660		CC73HCH1H100D	CHIP C 10PF D		C819		CK73HB1H103K	CHIP C 10000PF K	
C661		CK73HB1E104K	CHIP C 0.10UF K		C820		CK73HBB1H471K	CHIP C 470PF K	
C662		CC73HCH1H050C	CHIP C 5.0PF C	K	C821		CK73HB1E104K	CHIP C 0.10UF K	
C662		CC73HCH1H070B	CHIP C 7.0PF B	K2	C822		CC73HCH1H100D	CHIP C 10PF D	
C663		CK73HB1H103K	CHIP C 10000PF K		C823		CK73HB1E104K	CHIP C 0.10UF K	
C664		CC73HCH1H3R5B	CHIP C 3.5PF B	K2	C825		C93-1824-05	CHIP C 100UF M	
C665		CC73HCH1H030B	CHIP C 3.0PF B	K	C826		CK73GB1E105K	CHIP C 1.0UF K	
C668		CC73HCH1H030B	CHIP C 3.0PF B	K	C827		CK73HBB1H471K	CHIP C 470PF K	
C671		CC73HCH1H010B	CHIP C 1.0PF B	K	C828		CK73HB1E104K	CHIP C 0.10UF K	
C671		CC73HCH1H040B	CHIP C 4.0PF B	K2	C831		CK73HB1E104K	CHIP C 0.10UF K	
C672		CK73HBB1H471K	CHIP C 470PF K		C832		CC73HCH1H050B	CHIP C 5.0PF B	
C673		CK73HBB1H471K	CHIP C 470PF K		C842		CK73HBB1H471K	CHIP C 470PF K	K
C674		CC73HCH1H030B	CHIP C 3.0PF B	K	C843		CK73HBB1H471K	CHIP C 470PF K	K
C674		CC73HCH1H040B	CHIP C 4.0PF B	K2	C844		CK73HBB1H471K	CHIP C 470PF K	K
C677		CC73HCH1H060B	CHIP C 6.0PF B	K2	C845		CC73HCH1H101J	CHIP C 100PF J	K
C677		CC73HCH1H100D	CHIP C 10PF D	K	C846		CC73HCH1H101J	CHIP C 100PF J	K
C679		CK73HBB1H471K	CHIP C 470PF K		CF400		L72-1028-05	CERAMIC FILTER	
C680		CK73HBB1H471K	CHIP C 470PF K		CF401		L72-1028-05	CERAMIC FILTER	
C683		CK73HBB1H471K	CHIP C 470PF K		CF402		L72-1027-05	CERAMIC FILTER	
C684		CK73HBB1H471K	CHIP C 470PF K		CF403		L72-1041-05	CERAMIC FILTER	
C685		CK73HBB1H471K	CHIP C 470PF K		CN101		E04-0491-05	PIN SOCKET	
C686		CK73HBB1H471K	CHIP C 470PF K		CN102		E23-1330-05	TERMINAL	
C687		CK73HBB1H471K	CHIP C 470PF K		CN103		E23-1330-05	TERMINAL	K
C688		CK73HBB1H471K	CHIP C 470PF K		CN106		E23-1330-05	TERMINAL	
C690		CK73HBB1H471K	CHIP C 470PF K	K	CN500		E04-0491-05	PIN SOCKET	
C691		CK73HBB1H471K	CHIP C 470PF K	K	CN610		E04-0491-05	PIN SOCKET	
C700		CK73HB1H103K	CHIP C 10000PF K		CN700		E41-2672-05	PIN ASSY	
C701		C92-0905-05	OS-CON 47UF 35WV		CN701		E41-2672-05	PIN ASSY	

PARTS LIST

TX-RX UNIT (X57-897K-XX)

Ref. No.	Address	Parts No.	Description	Destination	Ref. No.	Address	Parts No.	Description	Destination
CN800		E40-6656-05	PIN ASSY		IC801		TC75S51FE(F)	MOS-IC	
CN801		E41-2743-05	PIN ASSY		IC802		M24C02-RMN6TP	ROM IC	
CN802		E04-0193-05	PIN SOCKET		IC803		BU7242NUX	MOS-IC	
CN807		E23-1278-05	TERMINAL		IC804		M62364FP-F	MOS-IC	
CN808		E23-1278-05	TERMINAL		IC805		MCP23S08TE/ML	MOS-IC	
CN809		E23-1278-05	TERMINAL		IC806		TC7W53FKF	MOS-IC	
CN811		E23-1278-05	TERMINAL		L100		LR79Z0DD21N9J	SMALL FIXED INDUCTOR (21.9NH)	
CN812		E23-1278-05	TERMINAL		L101		LR79Z0DD21N9J	SMALL FIXED INDUCTOR (21.9NH)	
CN813		E23-1278-05	TERMINAL		L103		LR79Z0DD21N9J	SMALL FIXED INDUCTOR (21.9NH)	
D100		1SV283F	VARIABLE CAPACITANCE DIODE		L104		LR79Z0DD21N9J	SMALL FIXED INDUCTOR (21.9NH)	
D101		1SV283F	VARIABLE CAPACITANCE DIODE		L106		LB73G0AK-001	CHIP FERRITE BEADS	
D103		1SV283F	VARIABLE CAPACITANCE DIODE		L107		L41-1078-14	SMALL FIXED INDUCTOR (10NH)	K
D104		1SV283F	VARIABLE CAPACITANCE DIODE		L107		L41-1278-14	SMALL FIXED INDUCTOR (12NH)	K2
D105		1SV283F	VARIABLE CAPACITANCE DIODE		L109		L41-5668-14	SMALL FIXED INDUCTOR (5.6NH)	K
D106		1SV283F	VARIABLE CAPACITANCE DIODE		L109		L41-6868-14	SMALL FIXED INDUCTOR (6.8NH)	K2
D107		1SV283F	VARIABLE CAPACITANCE DIODE		L111		LR79Z0DD21N9J	SMALL FIXED INDUCTOR (21.9NH)	
D108		1SV283F	VARIABLE CAPACITANCE DIODE		L112		LR79Z0DD21N9J	SMALL FIXED INDUCTOR (21.9NH)	
D200		KDS123E-P	DIODE		L114		LR79Z0DD21N9J	SMALL FIXED INDUCTOR (21.9NH)	
D500		UDZS3.0B	ZENER DIODE		L115		LR79Z0DD21N9J	SMALL FIXED INDUCTOR (21.9NH)	
D501		UDZS3.0B	ZENER DIODE		L116		LR79Z0DD21N9J	SMALL FIXED INDUCTOR (21.9NH)	
D503		HSM88AS-E	DIODE		L117		LR79Z0DD21N9J	SMALL FIXED INDUCTOR (21.9NH)	
D504		JDP4P02AT	DIODE		L118		LR79Z0DD21N9J	SMALL FIXED INDUCTOR (21.9NH)	
D505		JDP4P02AT	DIODE		L119		L34-4616-05	AIR-CORE COIL	
D600		KDS123E-P	DIODE		L120		L41-1578-14	SMALL FIXED INDUCTOR (15NH)	K
D601		RN142S	DIODE		L120		L41-1878-14	SMALL FIXED INDUCTOR (18NH)	K2
D801		1SS388F	DIODE		L121		L41-1578-14	SMALL FIXED INDUCTOR (15NH)	K
F700		F53-0328-15	FUSE (5A)		L121		L41-1878-14	SMALL FIXED INDUCTOR (18NH)	K2
IC100		LMC7101BIM5	MOS-IC		L200		L41-2278-14	SMALL FIXED INDUCTOR (22NH)	K
IC101		LMC7101BIM5	MOS-IC		L200		L41-2778-14	SMALL FIXED INDUCTOR (27NH)	K2
IC200		BU7242NUX	MOS-IC		L201		L41-2278-14	SMALL FIXED INDUCTOR (22NH)	K
IC201		LMC7101BIM5	MOS-IC		L201		L41-2778-14	SMALL FIXED INDUCTOR (27NH)	K2
IC203		TC7SH126FU-F	MOS-IC		L203		L41-5685-14	SMALL FIXED INDUCTOR (560NH)	
IC300		ADL5350ACPZ	MOS-IC		L205		L41-4778-14	SMALL FIXED INDUCTOR (47NH)	
IC400		AD8051ART	ANALOGUE IC		L206		L41-1085-33	SMALL FIXED INDUCTOR (0.1UH)	K2
IC401		BU7242NUX	MOS-IC		L206		L41-1585-33	SMALL FIXED INDUCTOR (0.15UH)	K
IC402		LMC7101BIM5	MOS-IC		L207		L41-2278-14	SMALL FIXED INDUCTOR (22NH)	
IC403		NJM2287V	MOS-IC		L208		L41-1275-33	SMALL FIXED INDUCTOR (0.012UH)	K
IC404		MCP6021-E/OT	MOS-IC		L209		L41-1275-33	SMALL FIXED INDUCTOR (0.012UH)	K
IC405		TC7W53FKF	MOS-IC		L209		L41-1575-33	SMALL FIXED INDUCTOR (0.015UH)	K2
IC406		TC7W53FKF	MOS-IC		L210		L41-1275-33	SMALL FIXED INDUCTOR (0.012UH)	K
IC407		TC7W53FKF	MOS-IC		L210		L41-1875-33	SMALL FIXED INDUCTOR (0.018UH)	K2
IC408		TC7W53FKF	MOS-IC		L211		L41-3378-14	SMALL FIXED INDUCTOR (33NH)	
IC409		BU7242NUX	MOS-IC		L212		LB73G0AK-001	CHIP FERRITE BEADS	
IC500		BU7242NUX	MOS-IC		L214		LB73G0AK-001	CHIP FERRITE BEADS	
IC501		TC75S59F-F	MOS-IC		L215		LB73H0AV-003	CHIP FERRITE BEADS	
IC600		TC7WH126FU-F	MOS-IC		L300		LB73G0AK-001	CHIP FERRITE BEADS	
IC601		TC7WH126FU-F	MOS-IC		L301		LK73G0AQR33K	SMALL FIXED INDUCTOR (330NH)	
IC602		ADF4001BRUZ	MOS-IC		L302		L41-5685-47	SMALL FIXED INDUCTOR (560NH)	
IC603		BU7465HFV	MOS-IC		L303		L41-3385-47	SMALL FIXED INDUCTOR (330NH)	K2
IC604		LMC7101BIM5	MOS-IC		L303		L41-3985-47	SMALL FIXED INDUCTOR (390NH)	K
IC605		BU7465HFV	MOS-IC		L304		L41-1578-14	SMALL FIXED INDUCTOR (15NH)	
IC606		LMC7101BIM5	MOS-IC		L305		L41-1578-14	SMALL FIXED INDUCTOR (15NH)	
IC607		LMC7101BIM5	MOS-IC		L308		L41-1878-14	SMALL FIXED INDUCTOR (18NH)	K
IC608		BU7242NUX	MOS-IC		L308		L41-2278-14	SMALL FIXED INDUCTOR (22NH)	K2
IC700		NJM78M05DL1AZB	ANALOGUE IC		L309		L41-6878-14	SMALL FIXED INDUCTOR (68NH)	
IC701		XC9101D09AK-G	MOS-IC		L310		L41-2785-47	SMALL FIXED INDUCTOR (270NH)	K
IC702		NJM78M08FA-ZB	ANALOGUE IC		L310		L41-3385-47	SMALL FIXED INDUCTOR (330NH)	K2
IC703		TK71733S	BI-POLAR IC		L312		L41-1078-14	SMALL FIXED INDUCTOR (10NH)	
IC704		TK11230CMCL-G	BI-POLAR IC		L313		LK73G0AF82NJ	SMALL FIXED INDUCTOR (82NH)	
IC800		LM73CIMKX-0	MOS-IC		L315		L41-1078-14	SMALL FIXED INDUCTOR (10NH)	

PARTS LIST

TX-RX UNIT (X57-897K-XX)

Ref. No.	Address	Parts No.	Description	Desti- nation	Ref. No.	Address	Parts No.	Description	Desti- nation
L316		LK73G0AFR27J	SMALL FIXED INDUCTOR (270NH)		Q506		EM6M2	FET	
L317		L41-1095-33	SMALL FIXED INDUCTOR (1.0UH)		Q507		UPA672T-A	FET	
L320		LK73G0AFR18J	SMALL FIXED INDUCTOR (180NH)		Q600		SSM3K15AMFVF	FET	
L500		L41-3395-33	SMALL FIXED INDUCTOR (3.3UH)		Q601		KTA2014E-P(GR)	TRANSISTOR	
L501		L41-4795-33	SMALL FIXED INDUCTOR (4.7UH)		Q602		KTC4075E-P(GR)	TRANSISTOR	
L502		L41-6885-33	SMALL FIXED INDUCTOR (0.68UH)		Q603		KTC4075E-P(GR)	TRANSISTOR	
L503		L41-5685-33	SMALL FIXED INDUCTOR (0.56UH)		Q604		DSC90010(S)	TRANSISTOR	
L504		L41-2295-33	SMALL FIXED INDUCTOR (2.2UH)		Q605		DSC90010(S)	TRANSISTOR	
L505		L41-1295-33	SMALL FIXED INDUCTOR (1.2UH)		Q606		2SC4725	TRANSISTOR	K
L506		L41-1295-33	SMALL FIXED INDUCTOR (1.2UH)		Q606		2SC5636	TRANSISTOR	K2
L507		L41-3305-33	SMALL FIXED INDUCTOR (33UH)		Q607		SSM3K15AMFVF	FET	
L508		L41-3305-33	SMALL FIXED INDUCTOR (33UH)		Q700		CPH3317	FET	
L600		L41-1005-33	SMALL FIXED INDUCTOR (10UH)		Q701		SSM3K15AMFVF	FET	
L601		L41-1005-33	SMALL FIXED INDUCTOR (10UH)		Q702		2SJ506-E(S)	FET	
L602		LB73G0AK-001	CHIP FERRITE BEADS		Q703		LTC014EUBFS8	DIGITAL TRANSISTOR	
L603		L41-1005-33	SMALL FIXED INDUCTOR (10UH)		Q704		SSM5H01TU-F	FET	
L604		L41-3385-39	SMALL FIXED INDUCTOR (330NH)		Q705		CPH3317	FET	
L605		L41-3985-39	SMALL FIXED INDUCTOR (390NH)		Q706		SSM3K15AMFVF	FET	
L606		L41-1095-39	SMALL FIXED INDUCTOR (1.0UH)		Q800		SSM3K15AMFVF	FET	
L607		L41-1878-14	SMALL FIXED INDUCTOR (18NH)	K2	R100		RK73GB2A102J	CHIP R 1.0K J 1/10W	
L607		L41-2278-14	SMALL FIXED INDUCTOR (22NH)	K	R101		RK73HB1J000J	CHIP R 0.0 J 1/16W	
L608		L41-1878-14	SMALL FIXED INDUCTOR (18NH)	K2	R105		RK73HB1J104J	CHIP R 100K J 1/16W	
L608		L41-2278-14	SMALL FIXED INDUCTOR (22NH)	K	R106		RK73HB1J104J	CHIP R 100K J 1/16W	
L609		L41-1078-14	SMALL FIXED INDUCTOR (10NH)	K	R107		RK73HB1J103J	CHIP R 10K J 1/16W	
L609		L41-1278-14	SMALL FIXED INDUCTOR (12NH)	K2	R109		RK73HB1J104J	CHIP R 100K J 1/16W	
L610		L41-2278-14	SMALL FIXED INDUCTOR (22NH)	K	R110		RK73HB1J104J	CHIP R 100K J 1/16W	
L610		L41-2778-14	SMALL FIXED INDUCTOR (27NH)	K2	R111		RK73HB1J101J	CHIP R 100 J 1/16W	
L611		L41-1578-14	SMALL FIXED INDUCTOR (15NH)	K2	R112		RK73HB1J104J	CHIP R 100K J 1/16W	
L611		L41-2278-14	SMALL FIXED INDUCTOR (22NH)	K	R113		RK73HB1J103J	CHIP R 10K J 1/16W	
L613		LB73G0AM-004	CHIP FERRITE BEADS		R114		RK73HB1J101J	CHIP R 100 J 1/16W	
L614		LB73G0AM-004	CHIP FERRITE BEADS		R115		RK73FB2B121J	CHIP R 120 J 1/8W	
L615		LB73G0AK-001	CHIP FERRITE BEADS		R116		RK73HB1J103J	CHIP R 10K J 1/16W	
L616		LB73G0AK-001	CHIP FERRITE BEADS		R117		RK73HB1J100J	CHIP R 10 J 1/16W	
L617		LB73G0AK-001	CHIP FERRITE BEADS		R118		RK73HB1J274J	CHIP R 270K J 1/16W	
L619		LB73H0AV-003	CHIP FERRITE BEADSK		R119		RK73HB1J393J	CHIP R 39K J 1/16W	
L700		L33-1462-05	SMALL FIXED INDUCTOR (68UH)		R120		RK73HB1J122J	CHIP R 1.2K J 1/16W	
L701		L41-1005-33	SMALL FIXED INDUCTOR (10UH)		R121		RK73HB1J102J	CHIP R 1.0K J 1/16W	
L702		L41-1005-33	SMALL FIXED INDUCTOR (10UH)		R122		RK73HB1J221J	CHIP R 220 J 1/16W	
L800		LB73G0AK-001	CHIP FERRITE BEADS		R125		RK73HB1J000J	CHIP R 0.0 J 1/16W	
L801		LB73G0AK-001	CHIP FERRITE BEADS		R126		RK73HB1J103J	CHIP R 10K J 1/16W	
L803		LB73H0AV-002	CHIP FERRITE BEADS		R128		RK73HB1J000J	CHIP R 0.0 J 1/16W	
L804		L41-1285-14	SMALL FIXED INDUCTOR (120NH)		R129		RK73HB1J000J	CHIP R 0.0 J 1/16W	
L805		LB73G0AK-001	CHIP FERRITE BEADS		R130		RK73HB1J274J	CHIP R 270K J 1/16W	
L806		LB73G0AK-001	CHIP FERRITE BEADS		R131		RK73HB1J393J	CHIP R 39K J 1/16W	
Q100		DSC90010(S)	TRANSISTOR		R132		RK73HB1J104J	CHIP R 100K J 1/16W	
Q101		2SC5337	TRANSISTOR		R133		RK73HB1J104J	CHIP R 100K J 1/16W	
Q200		DSC90010(S)	TRANSISTOR		R134		RK73HB1J104J	CHIP R 100K J 1/16W	
Q201		DSC90010(S)	TRANSISTOR		R135		RK73HB1J104J	CHIP R 100K J 1/16W	
Q202		2SC5108F/Y/	TRANSISTOR	K	R136		RK73HB1J104J	CHIP R 100K J 1/16W	
Q202		2SC5636	TRANSISTOR	K2	R137		RK73HB1J4R7J	CHIP R 4.7 J 1/16W	
Q203		2SC5108F/Y/	TRANSISTOR	K	R138		RK73HB1J000J	CHIP R 0.0 J 1/16W	
Q203		2SC5636	TRANSISTOR	K2	R139		RK73HB1J000J	CHIP R 0.0 J 1/16W	
Q300		3SK294-FP	FET		R140		RK73HB1J220J	CHIP R 22 J 1/16W	
Q301		2SC5337	TRANSISTOR		R200		RK73HB1J223J	CHIP R 22K J 1/16W	
Q500		EM6M2	FET		R201		RK73HB1J103J	CHIP R 10K J 1/16W	
Q501		KTC4075E-P(GR)	TRANSISTOR		R202		RK73HB1J103J	CHIP R 10K J 1/16W	
Q502		2SK3737-5	FET		R203		RK73HB1J000J	CHIP R 0.0 J 1/16W	
Q503		3SK294-FP	FET		R204		RK73HB1J224J	CHIP R 220K J 1/16W	
Q504		KTC4075E-P(GR)	TRANSISTOR		R205		RK73HB1J102J	CHIP R 1.0K J 1/16W	
Q505		SSM3K15AMFVF	FET		R206		RK73HB1J334J	CHIP R 330K J 1/16W	

PARTS LIST

TX-RX UNIT (X57-897K-XX)

Ref. No.	Address	Parts No.	Description	Desti- nation	Ref. No.	Address	Parts No.	Description	Desti- nation
R207		RK73HB1J393J	CHIP R 39K J 1/16W		R404		RK73HB1J000J	CHIP R 0.0 J 1/16W	
R208		RK73HB1J000J	CHIP R 0.0 J 1/16W		R405		RK73HB1J103J	CHIP R 10K J 1/16W	
R209		RK73HB1J102J	CHIP R 1.0K J 1/16W		R406		RK73HB1J220J	CHIP R 22 J 1/16W	
R210		RK73HB1J124J	CHIP R 120K J 1/16W		R407		RK73HB1J474J	CHIP R 470K J 1/16W	
R211		RK73HB1J333J	CHIP R 33K J 1/16W		R409		RK73HB1J473J	CHIP R 47K J 1/16W	
R212		RK73HB1J394J	CHIP R 390K J 1/16W		R410		RK73HB1J473J	CHIP R 47K J 1/16W	
R213		RK73HB1J106J	CHIP R 10M J 1/16W		R411		RK73HB1J473J	CHIP R 47K J 1/16W	
R214		RK73HB1J000J	CHIP R 0.0 J 1/16W		R412		RK73HB1J101J	CHIP R 100 J 1/16W	
R215		RK73HB1J102J	CHIP R 1.0K J 1/16W		R413		RK73HB1J000J	CHIP R 0.0 J 1/16W	
R216		RK73HB1J102J	CHIP R 1.0K J 1/16W		R415		RK73HB1J223J	CHIP R 22K J 1/16W	
R220		RK73HB1J101J	CHIP R 100 J 1/16W		R416		RK73HB1J222J	CHIP R 2.2K J 1/16W	
R221		RK73HB1J101J	CHIP R 100 J 1/16W		R417		RK73HB1J220J	CHIP R 22 J 1/16W	
R223		RK73HB1J181J	CHIP R 180 J 1/16W	K	R418		RK73HB1J220J	CHIP R 22 J 1/16W	
R223		RK73HB1J331J	CHIP R 330 J 1/16W	K2	R419		RK73HB1J472J	CHIP R 4.7K J 1/16W	
R224		RK73HB1J220J	CHIP R 22 J 1/16W		R420		RK73HB1J470J	CHIP R 47 J 1/16W	
R225		RK73HB1J334J	CHIP R 330K J 1/16W		R421		RK73HB1J562J	CHIP R 5.6K J 1/16W	
R227		RK73HB1J220J	CHIP R 22 J 1/16W		R422		RK73HB1J101J	CHIP R 100 J 1/16W	
R228		RK73HB1J000J	CHIP R 0.0 J 1/16W		R425		RK73HB1J183J	CHIP R 18K J 1/16W	
R229		RK73HB1J000J	CHIP R 0.0 J 1/16W		R426		RK73HB1J822J	CHIP R 8.2K J 1/16W	
R230		RK73HB1J271J	CHIP R 270 J 1/16W		R427		RK73HB1J473J	CHIP R 47K J 1/16W	
R231		RK73HB1J180J	CHIP R 18 J 1/16W		R428		RK73HB1J473J	CHIP R 47K J 1/16W	
R232		RK73HB1J271J	CHIP R 270 J 1/16W		R429		RK73HB1J220J	CHIP R 22 J 1/16W	
R233		RK73HB1J472J	CHIP R 4.7K J 1/16W		R431		RK73HB1J000J	CHIP R 0.0 J 1/16W	
R234		RK73HB1J182J	CHIP R 1.8K J 1/16W		R433		RK73HB1J000J	CHIP R 0.0 J 1/16W	
R235		RK73HB1J220J	CHIP R 22 J 1/16W		R434		RK73HB1J000J	CHIP R 0.0 J 1/16W	
R236		RK73HB1J102J	CHIP R 1.0K J 1/16W		R435		RK73HB1J000J	CHIP R 0.0 J 1/16W	
R237		RK73HB1J680J	CHIP R 68 J 1/16W		R436		RK73HB1J152J	CHIP R 1.5K J 1/16W	
R238		RK73HB1J000J	CHIP R 0.0 J 1/16W		R437		RK73HB1J152J	CHIP R 1.5K J 1/16W	
R239		RK73HB1J000J	CHIP R 0.0 J 1/16W		R438		RK73HB1J152J	CHIP R 1.5K J 1/16W	
R243		RK73HB1J271J	CHIP R 270 J 1/16W		R442		RK73HB1J821J	CHIP R 820 J 1/16W	
R244		RK73HB1J180J	CHIP R 18 J 1/16W		R443		RK73HB1J821J	CHIP R 820 J 1/16W	
R245		RK73HB1J271J	CHIP R 270 J 1/16W		R444		RK73HB1J122J	CHIP R 1.2K J 1/16W	K2
R246		RK73HB1J221J	CHIP R 220 J 1/16W	K2	R444		RK73HB1J821J	CHIP R 820 J 1/16W	K
R246		RK73HB1J331J	CHIP R 330 J 1/16W	K	R447		RK73HB1J000J	CHIP R 0.0 J 1/16W	
R247		RK73HB1J103J	CHIP R 10K J 1/16W		R448		RK73HB1J334J	CHIP R 330K J 1/16W	
R300		RK73HB1J331J	CHIP R 330 J 1/16W		R449		RK73HB1J334J	CHIP R 330K J 1/16W	
R301		RK73HB1J101J	CHIP R 100 J 1/16W		R450		RK73HB1J563J	CHIP R 56K J 1/16W	
R302		RK73HB1J473J	CHIP R 47K J 1/16W		R451		RK73HB1J104J	CHIP R 100K J 1/16W	
R303		RK73HB1J220J	CHIP R 22 J 1/16W		R452		RK73HB1J224J	CHIP R 220K J 1/16W	
R304		RK73HB1J104J	CHIP R 100K J 1/16W		R453		RK73HB1J220J	CHIP R 22 J 1/16W	
R305		RK73HB1J123J	CHIP R 12K J 1/16W		R454		RK73HB1J000J	CHIP R 0.0 J 1/16W	
R306		RK73HB1J103J	CHIP R 10K J 1/16W		R500		RK73HB1J104J	CHIP R 100K J 1/16W	
R310		RK73HB1J122J	CHIP R 1.2K J 1/16W		R501		RK73HB1J104D	CHIP R 100K D 1/16W	
R311		RK73GB2A100J	CHIP R 10 J 1/10W	K2	R502		RK73HB1J104D	CHIP R 100K D 1/16W	
R311		RK73GB2A220J	CHIP R 22 J 1/10W	K	R503		RK73HB1J101J	CHIP R 100 J 1/16W	
R312		RK73HB1J100J	CHIP R 10 J 1/16W	K2	R504		RK73HB1J220J	CHIP R 22 J 1/16W	
R312		RK73HB1J220J	CHIP R 22 J 1/16W	K	R505		RK73HB1J124J	CHIP R 120K J 1/16W	
R313		RK73HB1J272J	CHIP R 2.7K J 1/16W		R506		RK73HB1J471J	CHIP R 470 J 1/16W	
R314		RK73HB1J103J	CHIP R 10K J 1/16W		R507		RK73HB1J220J	CHIP R 22 J 1/16W	
R315		RK73GB2A101J	CHIP R 100 J 1/10W		R509		RK73HB1J183J	CHIP R 18K J 1/16W	
R316		RK73GB2A100J	CHIP R 10 J 1/10W		R510		RK73HB1J223J	CHIP R 22K J 1/16W	
R318		RK73HB1J220J	CHIP R 22 J 1/16W		R511		RK73HB1J220J	CHIP R 22 J 1/16W	
R320		RK73HB1J100J	CHIP R 10 J 1/16W		R512		RK73HB1J223J	CHIP R 22K J 1/16W	
R323		RK73HB1J151J	CHIP R 150 J 1/16W	K2	R513		RK73HB1J471J	CHIP R 470 J 1/16W	
R323		RK73HB1J181J	CHIP R 180 J 1/16W	K	R514		RK73HB1J220J	CHIP R 22 J 1/16W	
R332		RK73HB1J470J	CHIP R 47 J 1/16W		R515		RK73HB1J272J	CHIP R 2.7K J 1/16W	
R400		RK73HB1J224J	CHIP R 220K J 1/16W		R516		RK73HB1J000J	CHIP R 0.0 J 1/16W	
R401		RK73HB1J220J	CHIP R 22 J 1/16W		R518		RK73HB1J102J	CHIP R 1.0K J 1/16W	
R402		RK73HB1J101J	CHIP R 100 J 1/16W		R519		RK73HB1J181J	CHIP R 180 J 1/16W	
R403		RK73HB1J000J	CHIP R 0.0 J 1/16W		R520		RK73HB1J394J	CHIP R 390K J 1/16W	

PARTS LIST

TX-RX UNIT (X57-897K-XX)

Ref. No.	Address	Parts No.	Description	Desti- nation	Ref. No.	Address	Parts No.	Description	Desti- nation
R521		RK73HB1J154J	CHIP R 150K J 1/16W	K2 K	R631		RK73HB1J822J	CHIP R 8.2K J 1/16W	
R522		RK73HB1J333J	CHIP R 33K J 1/16W		R632		RK73HB1J182J	CHIP R 1.8K J 1/16W	
R523		RK73HB1J000J	CHIP R 0.0 J 1/16W		R633		RK73HB1J220J	CHIP R 22 J 1/16W	
R524		RK73HB1J151J	CHIP R 150 J 1/16W		R634		RK73HB1J473J	CHIP R 47K J 1/16W	
R525		RK73HB1J104J	CHIP R 100K J 1/16W	R635		RK73GB2A2R2J	CHIP R 2.2 J 1/10W		
R525		RK73HB1J000J	CHIP R 0.0 J 1/16W	R636		RK73HB1J104J	CHIP R 100K J 1/16W		
R527		RK73HB1J104J	CHIP R 100K J 1/16W	R637		RK73HB1J473J	CHIP R 47K J 1/16W		
R528		RK73HB1J224J	CHIP R 220K J 1/16W	R638		RK73HB1J220J	CHIP R 22 J 1/16W		
R529		RK73HB1J104J	CHIP R 100K J 1/16W	R639		RK73HB1J000J	CHIP R 0.0 J 1/16W		
R530		RK73HB1J471J	CHIP R 470 J 1/16W	R640		RK73HB1J102J	CHIP R 1.0K J 1/16W		
R531		RK73HB1J103J	CHIP R 10K J 1/16W	R641		RK73HB1J000J	CHIP R 0.0 J 1/16W		
R532		RK73HB1J103J	CHIP R 10K J 1/16W	R642		RK73HB1J104J	CHIP R 100K J 1/16W		
R533		RK73HB1J220J	CHIP R 22 J 1/16W	R643		RK73HB1J104J	CHIP R 100K J 1/16W		
R534		RK73HB1J682J	CHIP R 6.8K J 1/16W	R644		RK73HB1J103J	CHIP R 10K J 1/16W		
R535		RK73HB1J104J	CHIP R 100K J 1/16W	R645		RK73HB1J220J	CHIP R 22 J 1/16W		
R536		RK73HB1J272J	CHIP R 2.7K J 1/16W	R646		RK73HB1J000J	CHIP R 0.0 J 1/16W		
R537		RK73HB1J102J	CHIP R 1.0K J 1/16W	R647		RK73HB1J102J	CHIP R 1.0K J 1/16W		
R538		RK73HB1J221J	CHIP R 220 J 1/16W	R648		RK73HB1J274J	CHIP R 270K J 1/16W		
R539		RK73HB1J104J	CHIP R 100K J 1/16W	R649		RK73HB1J000J	CHIP R 0.0 J 1/16W		
R540		RK73HB1J104J	CHIP R 100K J 1/16W	R650		RK73HB1J102J	CHIP R 1.0K J 1/16W		
R541		RK73HB1J101J	CHIP R 100 J 1/16W	R651		RK73HB1J102J	CHIP R 1.0K J 1/16W		
R542		RK73HB1J104J	CHIP R 100K J 1/16W	R652		RK73HB1J102J	CHIP R 1.0K J 1/16W		
R543		RK73HB1J221J	CHIP R 220 J 1/16W	R653		RK73HB1J124J	CHIP R 120K J 1/16W		
R544		RK73HB1J104J	CHIP R 100K J 1/16W	R654		RK73HB1J333J	CHIP R 33K J 1/16W		
R545		RK73HB1J120J	CHIP R 12 J 1/16W	R655		RK73HB1J394J	CHIP R 390K J 1/16W		
R546		RK73HB1J120J	CHIP R 12 J 1/16W	R656		RK73HB1J106J	CHIP R 10M J 1/16W		
R547		RK73HB1J182J	CHIP R 1.8K J 1/16W	R657		RK73HB1J223J	CHIP R 22K J 1/16W		
R548		RK73HB1J182J	CHIP R 1.8K J 1/16W	R658		RK73HB1J103J	CHIP R 10K J 1/16W		
R549		RK73HB1J182J	CHIP R 1.8K J 1/16W	R659		RK73HB1J224J	CHIP R 220K J 1/16W		
R550		RK73HB1J182J	CHIP R 1.8K J 1/16W	R660		RK73HB1J334J	CHIP R 330K J 1/16W		
R551		RK73HB1J101J	CHIP R 100 J 1/16W	R661		RK73HB1J393J	CHIP R 39K J 1/16W		
R552		RK73HB1J102J	CHIP R 1.0K J 1/16W	R663		RK73HB1J000J	CHIP R 0.0 J 1/16W	K2	
R602		RK73HB1J101J	CHIP R 100 J 1/16W	R665		RK73HB1J000J	CHIP R 0.0 J 1/16W		
R604		RK73HB1J104J	CHIP R 100K J 1/16W	R666		RK73HB1J101J	CHIP R 100 J 1/16W		
R605		RK73HB1J000J	CHIP R 0.0 J 1/16W	R668		RK73HB1J472J	CHIP R 4.7K J 1/16W		
R606		RK73HB1J104J	CHIP R 100K J 1/16W	R669		RK73HB1J182J	CHIP R 1.8K J 1/16W		
R607		RK73HB1J104J	CHIP R 100K J 1/16W	R670		RK73HB1J181J	CHIP R 180 J 1/16W		
R608		RK73HB1J104J	CHIP R 100K J 1/16W	R671		RK73HB1J220J	CHIP R 22 J 1/16W		
R609		RK73HB1J472J	CHIP R 4.7K J 1/16W	R680		RK73HB1J821J	CHIP R 820 J 1/16W		
R610		RK73HB1J000J	CHIP R 0.0 J 1/16W	R681		RK73HB1J586J	CHIP R 5.6 J 1/16W		
R611		RK73HB1J101J	CHIP R 100 J 1/16W	R682		RK73HB1J821J	CHIP R 820 J 1/16W		
R612		RK73HB1J470J	CHIP R 47 J 1/16W	R683		RK73HB1J000J	CHIP R 0.0 J 1/16W		
R613		RK73HB1J000J	CHIP R 0.0 J 1/16W	R684		RK73HB1J000J	CHIP R 0.0 J 1/16W		
R614		RK73HB1J223J	CHIP R 22K J 1/16W	R685		RK73HB1J000J	CHIP R 0.0 J 1/16W		
R615		RK73HB1J273J	CHIP R 27K J 1/16W	R686		RK73HB1J472J	CHIP R 4.7K J 1/16W		
R616		RK73HB1J103J	CHIP R 10K J 1/16W	R687		RK73HB1J472J	CHIP R 4.7K J 1/16W		
R617		RK73HB1J154J	CHIP R 150K J 1/16W	R688		RK73HB1J330J	CHIP R 33 J 1/16W	K2	
R618		RK73HB1J101J	CHIP R 100 J 1/16W	R688		RK73HB1J680J	CHIP R 68 J 1/16W	K	
R619		RK73HB1J221J	CHIP R 220 J 1/16W	R689		RK73HB1J101J	CHIP R 100 J 1/16W	K	
R620		RK73HB1J000J	CHIP R 0.0 J 1/16W	R689		RK73HB1J181J	CHIP R 180 J 1/16W	K2	
R621		RK73HB1J220J	CHIP R 22 J 1/16W	R690		RK73HB1J101J	CHIP R 100 J 1/16W	K	
R622		RK73HB1J103J	CHIP R 10K J 1/16W	R690		RK73HB1J181J	CHIP R 180 J 1/16W	K2	
R623		RK73HB1J562J	CHIP R 5.6K J 1/16W	R700		RK73HB1J330J	CHIP R 33 J 1/16W		
R624		RK73HB1J104J	CHIP R 100K J 1/16W	R701		RK73HB1J100J	CHIP R 10 J 1/16W		
R625		RK73HB1J221J	CHIP R 220 J 1/16W	R702		RK73HB1J473J	CHIP R 47K J 1/16W		
R626		RK73HB1J472J	CHIP R 4.7K J 1/16W	R703		RK73HB1J000J	CHIP R 0.0 J 1/16W		
R627		RK73HB1J220J	CHIP R 22 J 1/16W	R704		RK73HB1J472J	CHIP R 4.7K J 1/16W		
R628		RK73HB1J471J	CHIP R 470 J 1/16W	R705		RK73HB1J104J	CHIP R 100K J 1/16W		
R629		RK73HB1J104J	CHIP R 100K J 1/16W	R706		RK73HB1J102J	CHIP R 1.0K J 1/16W		
R630		RK73HB1J104J	CHIP R 100K J 1/16W	R707		RK73HB1J154J	CHIP R 150K J 1/16W		

TKR-D810

PARTS LIST

TX-RX UNIT (X57-897K-XX)

RX-VCO/PLL UNIT (X58-5210-XX)

Ref. No.	Address	Parts No.	Description	Desti-nation	Ref. No.	Address	Parts No.	Description	Desti-nation
R708		RK73HB1J473J	CHIP R 47K J 1/16W		R857		RK73HB1J000J	CHIP R 0.0 J 1/16W	K
R709		RK73HB1J473J	CHIP R 47K J 1/16W		R859		RK73HB1J000J	CHIP R 0.0 J 1/16W	
R710		RK73HB1J472J	CHIP R 4.7K J 1/16W		R861		RK73HB1J000J	CHIP R 0.0 J 1/16W	K2
R711		RK73HB1J123J	CHIP R 12K J 1/16W		X500		L77-3034-05	TCXO (19.2MHZ)	
R712		RK73HB1J474J	CHIP R 470K J 1/16W		X600		L77-1960-15	VCXO (16.8MHZ/1.5PPM)	
R713		RK73HH1J334D	CHIP R 330K D 1/16W		XF300		L71-0649-05	MCF(58.05MHZ)	
R714		RK73HH1J223D	CHIP R 22K D 1/16W		RX VCO/PLL UNIT (X58-5210-XX) -10:K2 -11:K				
R715		RK73HB1J000J	CHIP R 0.0 J 1/16W		-		F10-2377-14	SHIELDING CASE	
R716		RK73HB1J000J	CHIP R 0.0 J 1/16W		C300		CS77MA1VR15M	CHIP TNL 0.15UF 35WV	
R717		RK73HB1J000J	CHIP R 0.0 J 1/16W		C303		CS77ABE1D100M	CHIP C 10UF M	
R800		RK73HB1J000J	CHIP R 0.0 J 1/16W		C304		CC73GCH1H100C	CHIP C 10PF C	
R801		RK73HB1J000J	CHIP R 0.0 J 1/16W		C306		CC73GCH1H100C	CHIP C 10PF C	
R802		RK73HB1J000J	CHIP R 0.0 J 1/16W		C307		CS77MA1V0R1M	CHIP TNL 0.1UF 35WV	
R803		RK73HB1J000J	CHIP R 0.0 J 1/16W		C308		CK73HBB1E103K	CHIP C 0.01UF K	
R806		RK73HB1J000J	CHIP R 0.0 J 1/16W		C309		CK73HBB1E103K	CHIP C 0.01UF K	
R807		RK73HB1J000J	CHIP R 0.0 J 1/16W		C310		CK73HBB1E103K	CHIP C 0.01UF K	
R808		RK73HB1J000J	CHIP R 0.0 J 1/16W		C311		CK73HBB1H471K	CHIP C 470PF K	
R809		RK73HB1J000J	CHIP R 0.0 J 1/16W		C312		CC73GCH1H060B	CHIP C 6.0PF B	K
R810		RK73HB1J000J	CHIP R 0.0 J 1/16W		C312		CC73GCH1H070B	CHIP C 7.0PF B	K2
R811		RK73HB1J000J	CHIP R 0.0 J 1/16W		C313		CC73HCH1H101J	CHIP C 100PF J	
R812		RK73HB1J000J	CHIP R 0.0 J 1/16W		C314		CS77BA1E010M	CHIP TNL 1.0UF 25WV	
R813		RK73HB1J000J	CHIP R 0.0 J 1/16W		C315		CC73HCH1H101J	CHIP C 100PF J	
R814		RK73HB1J000J	CHIP R 0.0 J 1/16W		C316		CC73HCH1H101J	CHIP C 100PF J	
R815		RK73HB1J000J	CHIP R 0.0 J 1/16W		C317		CK73HBB1E103K	CHIP C 0.01UF K	
R816		RK73HB1J101J	CHIP R 100 J 1/16W		C318		CC73HCH1H101J	CHIP C 100PF J	
R817		RK73HB1J101J	CHIP R 100 J 1/16W		C320		CC73HCH1H101J	CHIP C 100PF J	
R818		RK73HB1J102J	CHIP R 1.0K J 1/16W		C321		CC73HCH1H101J	CHIP C 100PF J	
R819		RK73HB1J683J	CHIP R 68K J 1/16W		C322		CC73HCH1H101J	CHIP C 100PF J	
R820		RK73HB1J473J	CHIP R 47K J 1/16W		C324		CC73HCH1H101J	CHIP C 100PF J	
R821		RK73HB1J394J	CHIP R 390K J 1/16W		C325		CC73GCH1H100C	CHIP C 10PF C	K
R822		RK73HB1J104J	CHIP R 100K J 1/16W		C325		CC73GCH1H120G	CHIP C 12PF G	K2
R824		RK73HB1J101J	CHIP R 100 J 1/16W		C326		CC73HCH1H101J	CHIP C 100PF J	
R825		RK73HB1J101J	CHIP R 100 J 1/16W		C328		CC73GCH1H060B	CHIP C 6.0PF B	K
R826		RK73HB1J562J	CHIP R 5.6K J 1/16W		C328		CC73GCH1H070B	CHIP C 7.0PF B	K2
R827		RK73HB1J103J	CHIP R 10K J 1/16W		C329		CK73HBB1H471K	CHIP C 470PF K	
R828		RK73HB1J224J	CHIP R 220K J 1/16W		C330		CC73HCH1H040B	CHIP C 4.0PF B	
R829		RK73HB1J220J	CHIP R 22 J 1/16W		C331		CK73HBB1H471K	CHIP C 470PF K	
R830		RK73HB1J334J	CHIP R 330K J 1/16W		C332		CC73HCH1H100C	CHIP C 10PF C	
R831		RK73HB1J563J	CHIP R 56K J 1/16W		C333		CK73HBB1E103K	CHIP C 0.01UF K	
R832		RK73HB1J683J	CHIP R 68K J 1/16W		C335		CC73HCH1H101J	CHIP C 100PF J	
R833		RK73HB1J101J	CHIP R 100 J 1/16W		C352		CC73HCH1H101J	CHIP C 100PF J	
R834		RK73HB1J101J	CHIP R 100 J 1/16W		C353		CC73HCH1H101J	CHIP C 100PF J	
R835		RK73HB1J101J	CHIP R 100 J 1/16W		C354		CC73GCH1H390J	CHIP C 39PF J	
R837		RK73HB1J000J	CHIP R 0.0 J 1/16W		C355		CC73GCH1H390J	CHIP C 39PF J	
R838		RK73HB1J101J	CHIP R 100 J 1/16W		C356		CK73HBB1H471K	CHIP C 470PF K	
R840		RK73HB1J101J	CHIP R 100 J 1/16W		C357		CK73HBB1H471K	CHIP C 470PF K	
R841		RK73HB1J101J	CHIP R 100 J 1/16W		C358		CK73HBB1E103K	CHIP C 0.01UF K	
R842		RK73HB1J104J	CHIP R 100K J 1/16W		C359		CK73HBB1E103K	CHIP C 0.01UF K	
R843		RK73HB1J104J	CHIP R 100K J 1/16W		C360		CK73HBB1H471K	CHIP C 470PF K	
R844		RK73HB1J104J	CHIP R 100K J 1/16W		C361		CK73HBB1H471K	CHIP C 470PF K	
R845		RK73HB1J104J	CHIP R 100K J 1/16W		C362		CC73GCH1H150J	CHIP C 15PF J	K
R846		RK73HB1J104J	CHIP R 100K J 1/16W		C362		CC73GCH1H270J	CHIP C 27PF J	K2
R847		RK73HB1J104J	CHIP R 100K J 1/16W		C363		CC73GCH1H100C	CHIP C 10PF C	K
R848		RK73HB1J104J	CHIP R 100K J 1/16W		C363		CC73GCH1H180G	CHIP C 18PF G	K2
R849		RK73HB1J104J	CHIP R 100K J 1/16W		C364		CC73GCH1H030B	CHIP C 3.0PF B	K
R850		RK73HB1J000J	CHIP R 0.0 J 1/16W		C364		CC73GCH1H060B	CHIP C 6.0PF B	K2
R851		RK73HB1J000J	CHIP R 0.0 J 1/16W		C365		CC73GCH1H040B	CHIP C 4.0PF B	K2
R853		RK73HB1J000J	CHIP R 0.0 J 1/16W						
R855		RK73HB1J000J	CHIP R 0.0 J 1/16W						
R856		RK73GB2A220J	CHIP R 22 J 1/10W						

PARTS LIST

RX-VCO/PLL UNIT (X58-5210-XX)

Ref. No.	Address	Parts No.	Description	Desti- nation	Ref. No.	Address	Parts No.	Description	Desti- nation
C365		CC73GCH1H2R5B	CHIP C 2.5PF B	K	L357		L41-1095-33	SMALL FIXED INDUCTOR (1.0UH)	
C366		CK73HBB1H471K	CHIP C 470PF K		L358		L34-4607-15	AIR-CORE COIL	
C367		CK73HBB1H471K	CHIP C 470PF K		L359		L34-4607-15	AIR-CORE COIL	
C368		CC73GCH1H080B	CHIP C 8.0PF B	K	L360		L41-1098-40	SMALL FIXED INDUCTOR (1000NH)	
C368		CC73GCH1H100C	CHIP C 10PF C	K2	L361		L41-1098-40	SMALL FIXED INDUCTOR (1000NH)	
C369		CC73GCH1H070B	CHIP C 7.0PF B	K	L362		L41-1095-33	SMALL FIXED INDUCTOR (1.0UH)	
C369		CC73GCH1H080B	CHIP C 8.0PF B	K2	L363		L41-1095-33	SMALL FIXED INDUCTOR (1.0UH)	
C370		CC73GCH1H060B	CHIP C 6.0PF B	K2	L364		L41-2275-33	SMALL FIXED INDUCTOR (0.022UH)	
C370		CC73GCH1H070B	CHIP C 7.0PF B	K	L364		L41-3975-33	SMALL FIXED INDUCTOR (0.039UH)	K
C371		CC73GCH1H050B	CHIP C 5.0PF B	K2	L365		LB73H0AV-003	CHIP FERRITE BEADS	
C371		CC73GCH1H060B	CHIP C 6.0PF B	K	L366		LB73H0AV-003	CHIP FERRITE BEADS	
C372		CC73GCH1H040B	CHIP C 4.0PF B	K2	Q300		2SC5636	TRANSISTOR	
C372		CC73GCH1H050B	CHIP C 5.0PF B	K	Q350		SSM6L05FU-F	FET	
C373		CC73GCH1H030B	CHIP C 3.0PF B	K2	Q351		SSM6L05FU-F	FET	
C373		CC73GCH1H040B	CHIP C 4.0PF B	K	Q352		MCH3914-H/8/	FET	
C374		CC73GCH1H0R5B	CHIP C 0.5PF B		Q353		MCH3914-H/8/	FET	
C375		CC73GCH1H0R5B	CHIP C 0.5PF B		Q354		2SC5108F/Y/	TRANSISTOR	K
C376		CK73HBB1H471K	CHIP C 470PF K		Q354		2SC5636	TRANSISTOR	K2
C377		CK73HBB1H471K	CHIP C 470PF K		R301		RK73GB2A391J	CHIP R 390 J 1/16W	
C378		CC73HCH1H030B	CHIP C 3.0PF B	K	R302		RK73GB2A151J	CHIP R 150 J 1/10W	
C378		CC73HCH1H040C	CHIP C 4.0PF C	K2	R303		RK73GB2A000J	CHIP R 0.0 J 1/10W	
C379		CC730AD1H104J	CHIP C 100PF J		R304		RK73HB1J472J	CHIP R 4.7K J 1/16W	
C380		CC73GCH1H010B	CHIP C 1.0PF B	K	R305		RK73GB2A000J	CHIP R 0.0 J 1/10W	
C380		CC73GCH1H020B	CHIP C 2.0PF B	K2	R306		RK73HB1J100J	CHIP R 10 J 1/16W	
C381		CC73GCH1H020B	CHIP C 2.0PF B	K2	R307		RK73HB1J470J	CHIP R 47 J 1/16W	
C382		CC73GCH1H040B	CHIP C 4.0PF B	K	R308		RK73HB1J100J	CHIP R 10 J 1/16W	
C382		CC73GCH1H050B	CHIP C 5.0PF B	K2	R310		RK73HB1J102J	CHIP R 1.0K J 1/16W	
C383		CC73GCH1H040B	CHIP C 4.0PF B	K	R311		RK73HB1J100J	CHIP R 10 J 1/16W	
C383		CC73GCH1H050B	CHIP C 5.0PF B	K2	R312		RK73HB1J330J	CHIP R 33 J 1/16W	
CN303		E40-5816-05	PIN ASSY		R313		RK73HB1J103J	CHIP R 10K J 1/16W	
CN350		E40-6860-05	PIN ASSY		R314		RK73HB1J472J	CHIP R 4.7K J 1/16W	
CN351		E40-6098-05	PIN ASSY		R315		RK73HB1J101J	CHIP R 100 J 1/16W	
D352		1SV325F	VARIABLE CAPACITANCE DIODE		R316		RK73HB1J100J	CHIP R 10 J 1/16W	
D353		1SV325F	VARIABLE CAPACITANCE DIODE		R317		RK73HB1J101J	CHIP R 100 J 1/16W	
D355		1SV282-F	VARIABLE CAPACITANCE DIODE		R318		RK73HB1J121J	CHIP R 120 J 1/16W	K2
D357		1SV282-F	VARIABLE CAPACITANCE DIODE		R319		RK73HB1J151J	CHIP R 150 J 1/16W	
D358		1SV282-F	VARIABLE CAPACITANCE DIODE		R320		RK73HB1J223J	CHIP R 22K J 1/16W	
D359		1SV282-F	VARIABLE CAPACITANCE DIODE		R321		RK73HB1J103J	CHIP R 10K J 1/16W	
D360		1SV282-F	VARIABLE CAPACITANCE DIODE		R322		RK73HB1J8R2J	CHIP R 8.2 J 1/16W	
D361		1SV282-F	VARIABLE CAPACITANCE DIODE		R323		RK73HB1J151J	CHIP R 150 J 1/16W	
IC300		SKY72310362LF	MOS-IC		R324		RK73HB1J8R2J	CHIP R 8.2 J 1/16W	
L300		LB73H0AV-003	CHIP FERRITE BEADS		R325		RK73GB2A000J	CHIP R 0.0 J 1/10W	K2
L303		L41-1295-33	SMALL FIXED INDUCTOR(1.2UH)		R326		RK73GB2A000J	CHIP R 0.0 J 1/10W	K
L305		LB73H0AV-003	CHIP FERRITE BEADS		R327		RK73GB2A000J	CHIP R 0.0 J 1/10W	
L306		LB73H0AV-003	CHIP FERRITE BEADS		R331		RK73GB2A000J	CHIP R 0.0 J 1/10W	
L309		L41-1878-14	SMALL FIXED INDUCTOR (18NH)	K	R333		RK73HB1J000J	CHIP R 0.0 J 1/16W	
L309		L41-2278-14	SMALL FIXED INDUCTOR (22NH)	K2	R350		RK73HB1J474J	CHIP R 470K J 1/16W	
L310		LB73H0AV-003	CHIP FERRITE BEADS		R351		RK73HB1J474J	CHIP R 470K J 1/16W	
L312		LB73H0AV-003	CHIP FERRITE BEADS		R352		RK73HB1J000J	CHIP R 0.0 J 1/16W	
L313		LB73H0AV-003	CHIP FERRITE BEADS		R354		RK73HB1J474J	CHIP R 470K J 1/16W	
L315		L41-3378-14	SMALL FIXED INDUCTOR (33NH)		R357		RK73HB1J000J	CHIP R 0.0 J 1/16W	
L316		L41-1878-14	SMALL FIXED INDUCTOR (18NH)	K	R358		RK73HB1J000J	CHIP R 0.0 J 1/16W	
L316		L41-2278-14	SMALL FIXED INDUCTOR (22NH)	K2	R361		RN73GH1J330D	CHIP R 33 D 1/16W	
L350		L41-1095-33	SMALL FIXED INDUCTOR (1.0UH)		R362		RN73GH1J330D	CHIP R 33 D 1/16W	
L351		L41-1095-33	SMALL FIXED INDUCTOR (1.0UH)		R363		RN73GH1J271D	CHIP R 270 D 1/16W	
L352		L41-1095-33	SMALL FIXED INDUCTOR (1.0UH)		R364		RN73GH1J271D	CHIP R 270 D 1/16W	
L353		L41-1095-33	SMALL FIXED INDUCTOR (1.0UH)		R365		RN73GH1J470D	CHIP R 47 D 1/16W	
L354		L41-1095-33	SMALL FIXED INDUCTOR (1.0UH)		R366		RN73GH1J470D	CHIP R 47 D 1/16W	
L355		L41-1095-33	SMALL FIXED INDUCTOR (1.0UH)		R367		RK73HB1J330J	CHIP R 33 J 1/16W	
L356		L41-1095-33	SMALL FIXED INDUCTOR (1.0UH)		R368		RN73GH1J333D	CHIP R 33K D 1/16W	

PARTS LIST

RX-VCO/PLL UNIT (X58-5210-XX)

TX VCO/PLL UNIT (X58-5220-XX)

Ref. No.	Address	Parts No.	Description	Destination	Ref. No.	Address	Parts No.	Description	Destination
R369		RN73GH1J103D	CHIP R 10K D 1/16W		C362		CC73GCH1H120J	CHIP C 12PF J	
R370		RK73HB1J101J	CHIP R 100 J 1/16W		C363		CC73GCH1H090B	CHIP C 9.0PF B	K
R372		RK73HB1J000J	CHIP R 0.0 J 1/16W		C363		CC73GCH1H120J	CHIP C 12PF J	K2
R374		RK73GB2A000J	CHIP R 0.0 J 1/10W	K2	C364		CC73GCH1H020B	CHIP C 2.0PF B	K
R375		RK73GB2A000J	CHIP R 0.0 J 1/10W	K	C364		CC73GCH1H0R5B	CHIP C 0.5PF B	K2
R377		RK73GB2A000J	CHIP R 0.0 J 1/10W		C365		CC73GCH1H010B	CHIP C 1.0PF B	K2
R379		RK73HB1J000J	CHIP R 0.0 J 1/16W		C365		CC73GCH1H1R5B	CHIP C 1.5PF B	K
TX VCO/PLL UNIT (X58-5220-XX) -10:K2 -11:K					C366		CK73HBB1H471K	CHIP C 470PF K	
-		F10-2377-14	SHIELDING CASE		C367		CK73HBB1H471K	CHIP C 470PF K	
C300		C93-1906-05	CHIP FILM 0.047U 35V	K2	C368		CC73GCH1H060B	CHIP C 6.0PF B	K2
C300		CS77MA1VR15M	CHIP TNL 0.15UF 35WV	K	C369		CC73GCH1H050B	CHIP C 5.0PF B	
C303		CS77ABE1D100M	CHIP C 10UF M		C370		CC73GCH1H050B	CHIP C 5.0PF B	K2
C304		CC73GCH1H100C	CHIP C 10PF C		C370		CC73GCH1H070B	CHIP C 7.0PF B	K
C306		CC73GCH1H100C	CHIP C 10PF C		C371		CC73GCH1H040B	CHIP C 4.0PF B	K
C307		CS77MA1VR15M	CHIP TNL 0.15UF 35WV	K2	C371		CC73GCH1H050B	CHIP C 5.0PF B	K2
C307		CS77MA1VR15M	CHIP TNL 0.15UF 35WV	K	C372		CC73GCH1H050B	CHIP C 5.0PF B	K2
C308		CK73HBB1E103K	CHIP C 0.01UF K		C372		CC73GCH1H060B	CHIP C 6.0PF B	K
C309		CK73HBB1E103K	CHIP C 0.01UF K		C373		CC73GCH1H030B	CHIP C 3.0PF B	K
C310		CK73HBB1E103K	CHIP C 0.01UF K		C373		CC73GCH1H050B	CHIP C 5.0PF B	K2
C311		CK73HBB1H471K	CHIP C 470PF K		C374		CC73GCH1H0R5B	CHIP C 0.5PF B	
C312		CC73GCH1H050B	CHIP C 5.0PF B	K	C375		CC73GCH1H0R5B	CHIP C 0.5PF B	
C312		CC73GCH1H120G	CHIP C 12PF G	K2	C376		CK73HBB1H471K	CHIP C 470PF K	
C313		CC73HCH1H101J	CHIP C 100PF J		C377		CK73HBB1H471K	CHIP C 470PF K	
C314		CS77BA1E010M	CHIP TNL 1.0UF 25WV		C378		CC73HCH1H040C	CHIP C 4.0PF C	
C315		CC73HCH1H101J	CHIP C 100PF J		C379		CC730AD1H104J	CHIP C 100PF J	
C316		CC73HCH1H101J	CHIP C 100PF J		C382		CC73GCH1H030B	CHIP C 3.0PF B	K
C317		CK73HBB1E103K	CHIP C 0.01UF K		C382		CC73GCH1H050B	CHIP C 5.0PF B	K2
C318		CC73HCH1H101J	CHIP C 100PF J		C383		CC73GCH1H030B	CHIP C 3.0PF B	K2
C320		CC73HCH1H101J	CHIP C 100PF J		C383		CC73GCH1H050B	CHIP C 5.0PF B	K
C321		CC73HCH1H101J	CHIP C 100PF J		CN303		E40-5816-05	PIN ASSY	
C322		CC73HCH1H101J	CHIP C 100PF J		CN350		E40-6860-05	PIN ASSY	
C323		CC73GCH1H030B	CHIP C 3.0PF B	K2	CN351		E40-6098-05	PIN ASSY	
C324		CC73HCH1H101J	CHIP C 100PF J		D352		1SV325F	VARIABLE CAPACITANCE DIODE	K
C325		CC73GCH1H080B	CHIP C 8.0PF B	K	D352		1SV278F	VARIABLE CAPACITANCE DIODE	K2
C326		CC73HCH1H101J	CHIP C 100PF J		D353		1SV325F	VARIABLE CAPACITANCE DIODE	K
C328		CC73GCH1H050B	CHIP C 5.0PF B	K	D353		1SV278F	VARIABLE CAPACITANCE DIODE	K2
C328		CC73GCH1H120G	CHIP C 12PF G	K2	D355		1SV278F	VARIABLE CAPACITANCE DIODE	K
C329		CK73HBB1H471K	CHIP C 470PF K		D355		1SV282-F	VARIABLE CAPACITANCE DIODE	K2
C330		CC73HCH1H040C	CHIP C 4.0PF C	K	D357		1SV278F	VARIABLE CAPACITANCE DIODE	K
C330		CC73HCH1H3R5B	CHIP C 3.5PF B	K2	D357		1SV282-F	VARIABLE CAPACITANCE DIODE	K2
C331		CK73HBB1H471K	CHIP C 470PF K		D358		1SV278F	VARIABLE CAPACITANCE DIODE	
C332		CC73HCH1H100C	CHIP C 10PF C	K	D359		1SV278F	VARIABLE CAPACITANCE DIODE	
C332		CK73HBB1H471K	CHIP C 470PF K	K2	D360		1SV278F	VARIABLE CAPACITANCE DIODE	
C333		CK73HBB1E103K	CHIP C 0.01UF K		D361		1SV278F	VARIABLE CAPACITANCE DIODE	
C335		CC73HCH1H101J	CHIP C 100PF J		IC300		SKY72310362LF	MOS-IC	
C350		CC730AD1H104J	CHIP C 100PF J		L300		LB73H0AV-003	CHIP FERRITE BEADS	
C352		CC73HCH1H101J	CHIP C 100PF J	K	L303		L41-1295-33	SMALL FIXED INDUCTOR (1.2UH)	
C353		CC73HCH1H101J	CHIP C 100PF J	K	L305		LB73H0AV-003	CHIP FERRITE BEADS	
C354		CC73GCH1H470J	CHIP C 47PF J	K	L306		LB73H0AV-003	CHIP FERRITE BEADS	
C354		CK73GB1H471K	CHIP C 470PF K	K2	L307		L41-1078-14	SMALL FIXED INDUCTOR (10NH)	K2
C355		CC73GCH1H270J	CHIP C 27PF J	K	L308		L41-1578-14	SMALL FIXED INDUCTOR (15NH)	K
C355		CK73GB1H471K	CHIP C 470PF K	K2	L309		L41-1578-14	SMALL FIXED INDUCTOR (15NH)	K
C356		CK73HBB1H471K	CHIP C 470PF K		L309		L41-4778-14	SMALL FIXED INDUCTOR (47NH)	K2
C357		CK73HBB1H471K	CHIP C 470PF K		L310		LB73H0AV-003	CHIP FERRITE BEADS	
C358		CK73HBB1E103K	CHIP C 0.01UF K		L312		LB73H0AV-003	CHIP FERRITE BEADS	
C359		CK73HBB1E103K	CHIP C 0.01UF K		L313		LB73H0AV-003	CHIP FERRITE BEADS	
C360		CK73HBB1H471K	CHIP C 470PF K		L314		L41-1078-14	SMALL FIXED INDUCTOR (10NH)	K2
C361		CK73HBB1H471K	CHIP C 470PF K		L315		L41-2278-14	SMALL FIXED INDUCTOR (22NH)	K
					L315		L41-3978-14	SMALL FIXED INDUCTOR (39NH)	K2

PARTS LIST

TX VCO/PLL UNIT (X58-5220-XX)

Ref. No.	Address	Parts No.	Description	Desti- nation	Ref. No.	Address	Parts No.	Description	Desti- nation
L350		L41-1005-33	SMALL FIXED INDUCTOR (10UH)	K	R333		RK73HB1J000J	CHIP R 0.0 J 1/16W	
L350		L41-1095-33	SMALL FIXED INDUCTOR (1.0UH)	K2	R350		RK73HB1J474J	CHIP R 470K J 1/16W	
L351		L41-1005-33	SMALL FIXED INDUCTOR (10UH)	K	R351		RK73HB1J474J	CHIP R 470K J 1/16W	
L351		L41-1095-33	SMALL FIXED INDUCTOR (1.0UH)	K2	R353		RK73HB1J000J	CHIP R 0.0 J 1/16W	
L352		L41-1095-33	SMALL FIXED INDUCTOR (1.0UH)		R354		RK73HB1J474J	CHIP R 470K J 1/16W	
L353		L41-1095-33	SMALL FIXED INDUCTOR (1.0UH)		R355		RK73HB1J103J	CHIP R 10K J 1/16W	
L354		L41-1095-33	SMALL FIXED INDUCTOR (1.0UH)		R356		RK73HB1J220J	CHIP R 22 J 1/16W	K2
L355		L41-1095-33	SMALL FIXED INDUCTOR (1.0UH)		R356		RK73HB1J270J	CHIP R 27 J 1/16W	K
L356		L41-1095-33	SMALL FIXED INDUCTOR (1.0UH)		R357		RK73HB1J000J	CHIP R 0.0 J 1/16W	
L357		L41-1095-33	SMALL FIXED INDUCTOR (1.0UH)		R358		RK73HB1J000J	CHIP R 0.0 J 1/16W	
L358		L34-4607-15	AIR-CORE COIL	K	R361		RN73GH1J330D	CHIP R 33 D 1/16W	
L358		LR79Z0CM22NG	SMALL FIXED INDUCTOR (22NH)	K2	R362		RN73GH1J330D	CHIP R 33 D 1/16W	
L359		L34-4607-15	AIR-CORE COIL	K,K2	R363		RN73GH1J271D	CHIP R 270 D 1/16W	
L360		L41-1005-33	SMALL FIXED INDUCTOR (10UH)	K2	R364		RN73GH1J271D	CHIP R 270 D 1/16W	
L361		L41-1005-33	SMALL FIXED INDUCTOR (10UH)	K2	R365		RN73GH1J470D	CHIP R 47 D 1/16W	
L362		L41-1095-33	SMALL FIXED INDUCTOR (1.0UH)		R366		RN73GH1J470D	CHIP R 47 D 1/16W	
L363		L41-1095-33	SMALL FIXED INDUCTOR (1.0UH)		R367		RK73HB1J330J	CHIP R 33 J 1/16W	
L364		L41-1875-33	SMALL FIXED INDUCTOR (0.018UH)		R368		RN73GH1J333D	CHIP R 33K D 1/16W	
L365		LB73H0AV-003	CHIP FERRITE BEADS		R369		RN73GH1J103D	CHIP R 10K D 1/16W	
L366		LB73H0AV-003	CHIP FERRITE BEADS		R370		RK73HB1J820J	CHIP R 82 J 1/16W	
L367		L41-1098-40	SMALL FIXED INDUCTOR (1000NH)	K	R372		RK73HB1J000J	CHIP R 0.0 J 1/16W	
L368		L41-1098-40	SMALL FIXED INDUCTOR (1000NH)	K	R373		RK73HB1J474J	CHIP R 470K J 1/16W	
Q300		2SC5636	TRANSISTOR		R374		RK73GB2A000J	CHIP R 0.0 J 1/10W	K2
Q350		SSM6L05FU-F	FET		R375		RK73GB2A000J	CHIP R 0.0 J 1/10W	K
Q351		SSM6L05FU-F	FET		R377		RK73GB2A000J	CHIP R 0.0 J 1/10W	K,K2
Q352		MCH3914-H/8/	FET		R379		RK73HB1J000J	CHIP R 0.0 J 1/16W	K,K2
Q353		MCH3914-H/8/	FET						
Q354		2SC5108F/Y/	TRANSISTOR	K					
Q354		2SC5636	TRANSISTOR	K2					
R301		RK73GB2A391J	CHIP R 390 J 1/16W	K,K2					
R302		RK73GB2A121J	CHIP R 120 J 1/16W	K					
R302		RK73GB2A151J	CHIP R 150 J 1/10W	K2					
R303		RK73GB2A000J	CHIP R 0.0 J 1/10W						
R305		RK73GB2A000J	CHIP R 0.0 J 1/10W						
R306		RK73HB1J100J	CHIP R 10 J 1/16W						
R307		RK73HB1J560J	CHIP R 56 J 1/16W						
R308		RK73HB1J100J	CHIP R 10 J 1/16W						
R310		RK73HB1J102J	CHIP R 1.0K J 1/16W						
R311		RK73HB1J100J	CHIP R 10 J 1/16W						
R312		RK73HB1J330J	CHIP R 33 J 1/16W	K					
R312		RK73HB1J470J	CHIP R 47 J 1/16W	K2					
R313		RK73HB1J473J	CHIP R 47K J 1/16W						
R315		RK73HB1J101J	CHIP R 100 J 1/16W						
R316		RK73HB1J100J	CHIP R 10 J 1/16W						
R317		RK73HB1J101J	CHIP R 100 J 1/16W						
R318		RK73HB1J121J	CHIP R 120 J 1/16W	K					
R318		RK73HB1J222J	CHIP R 2.2K J 1/16W	K2					
R319		RK73HB1J151J	CHIP R 150 J 1/16W	K					
R319		RK73HB1J391J	CHIP R 390 J 1/16W	K2					
R320		RK73HB1J103J	CHIP R 10K J 1/16W	K2					
R320		RK73HB1J223J	CHIP R 22K J 1/16W	K					
R321		RK73HB1J103J	CHIP R 10K J 1/16W	K					
R321		RK73HB1J562J	CHIP R 5.6K J 1/16W	K2					
R322		RK73HB1J220J	CHIP R 22 J 1/16W						
R323		RK73HB1J470J	CHIP R 47 J 1/16W						
R324		RK73HB1J220J	CHIP R 22 J 1/16W						
R325		RK73GB2A000J	CHIP R 0.0 J 1/10W	K2					
R326		RK73GB2A000J	CHIP R 0.0 J 1/10W	K					
R327		RK73GB2A000J	CHIP R 0.0 J 1/10W						
R331		RK73GB2A000J	CHIP R 0.0 J 1/10W						

TKR-D810

EXPLODED VIEW

A		: N09-2292-05
B	M2.6 x 6	: N30-2606-48
C	M4 x 6	: N30-4006-48
D	M4 x 14	: N30-4014-48
E	M4 x 20	: N30-4020-43
F	M3 x 6	: N32-3006-48
G	M4 x 8	: N32-4008-43
H	M3 x 6	: N35-3006-43
J	M4 x 6	: N35-4006-43
K	M3 x 8	: N67-3008-48
L	∅2.6 x 8	: N80-2608-43
M	∅3 x 5	: N87-3005-43
N	∅3 x 6	: N87-3006-48

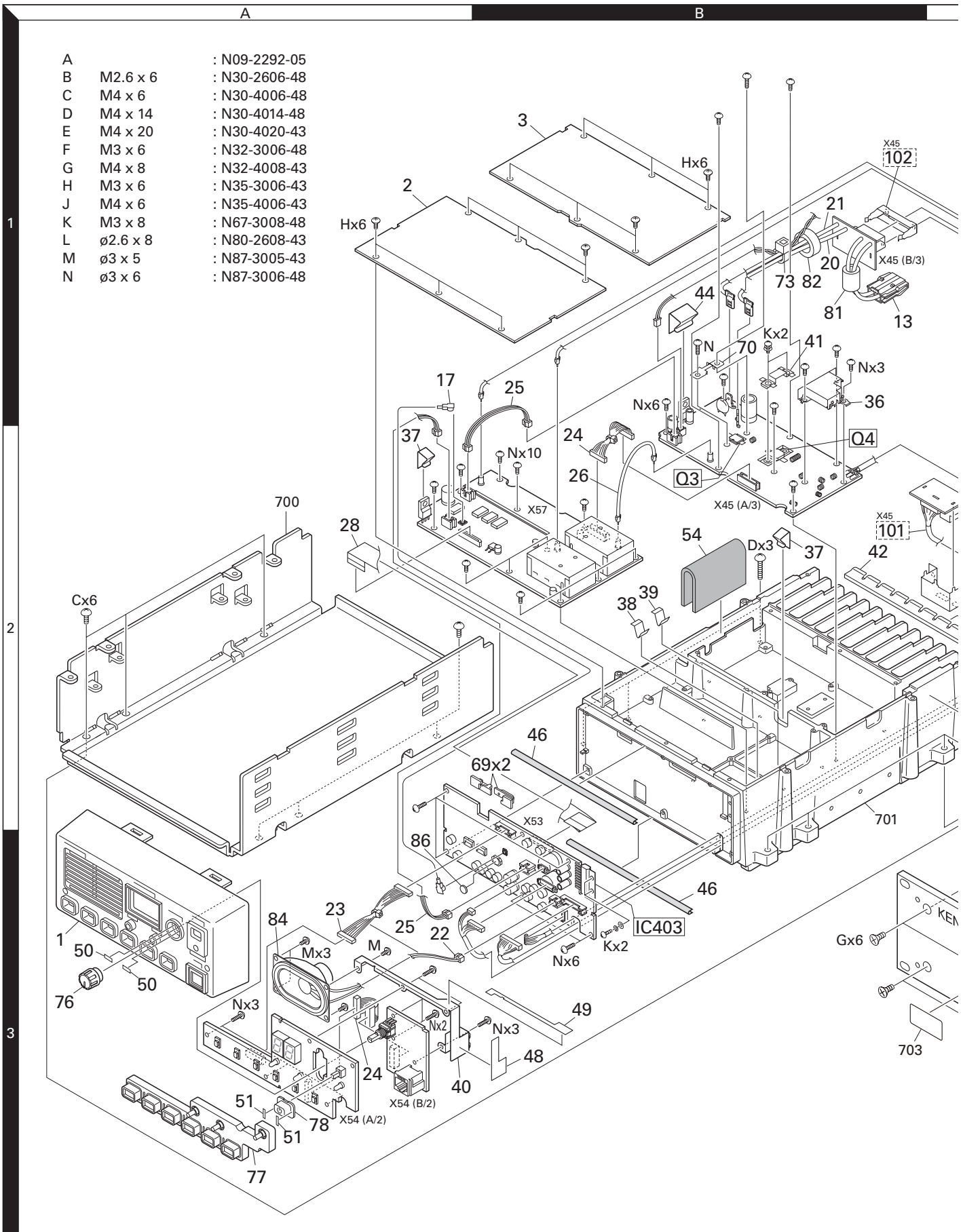

46 Parts with the exploded numbers larger than 700 are not supplied.
 If a part reference number is listed in a box on the exploded view of the PCB, that part does not come with the PCB.
 These parts must be ordered separately.

EXPLODED VIEW

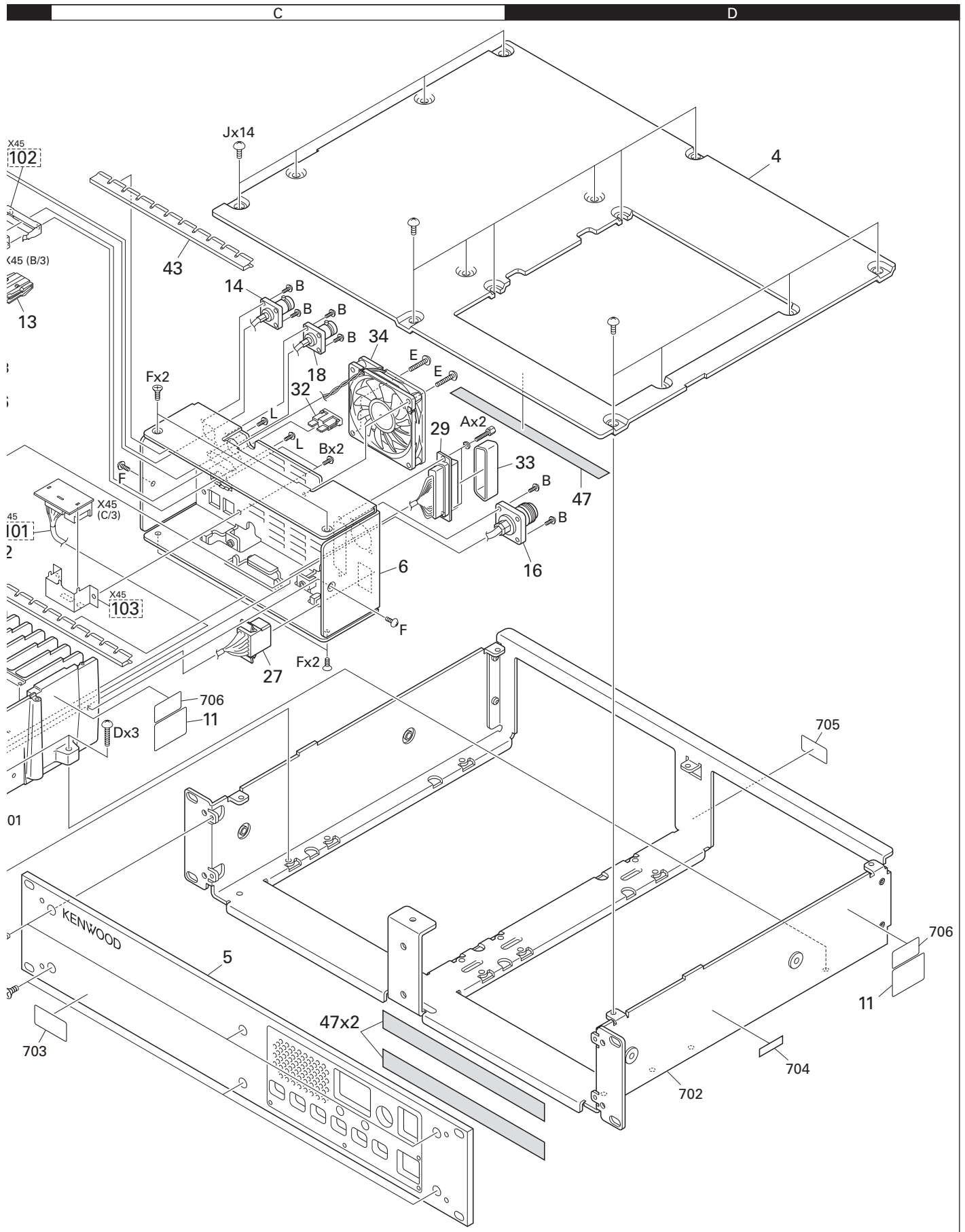

Parts with the exploded numbers larger than 700 are not supplied.
 If a part reference number is listed in a box on the exploded view of the PCB, that part does not come with the PCB. These parts must be ordered separately.

TKR-D810

PACKING

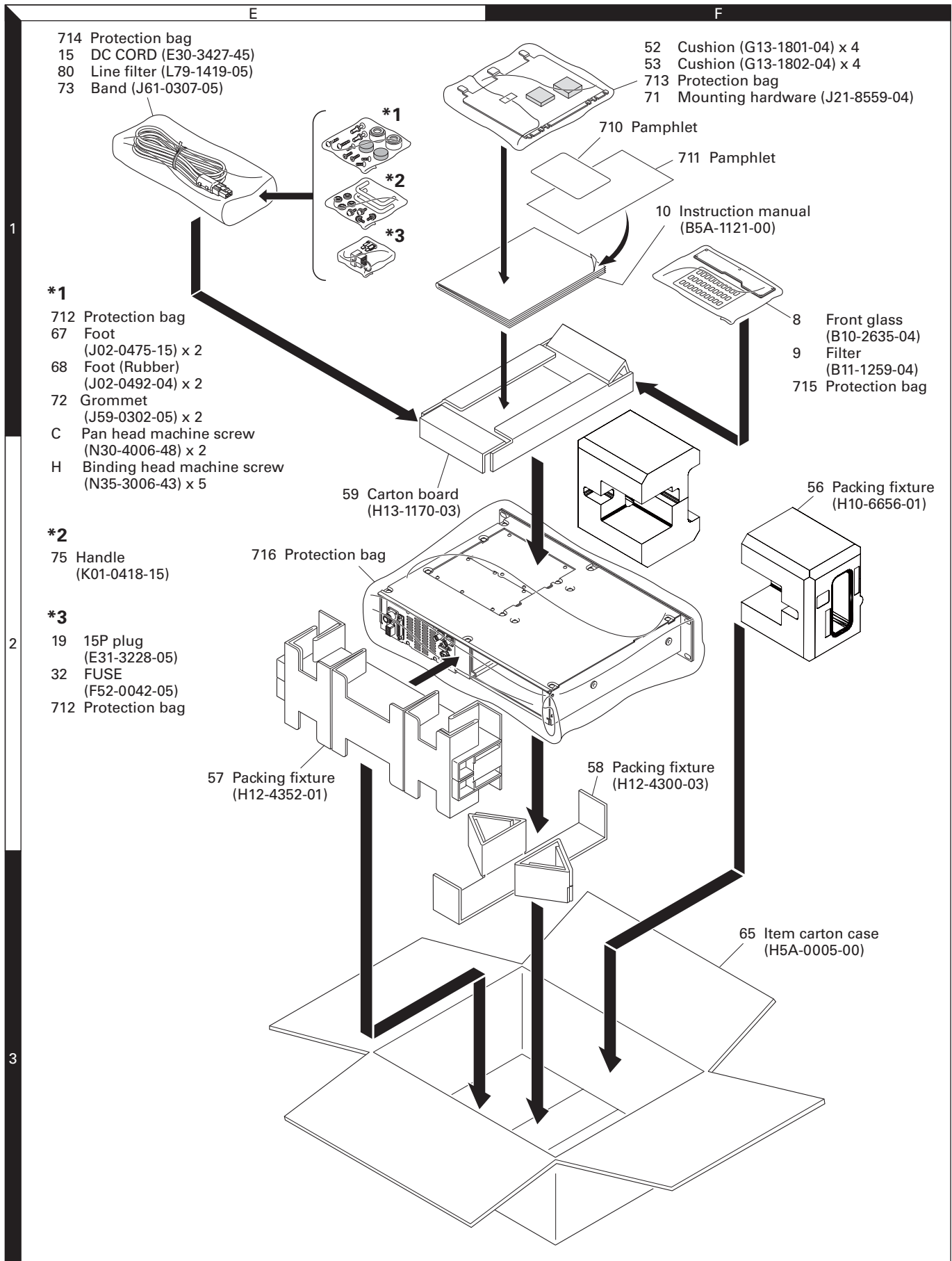

Parts with the exploded numbers larger than 700 are not supplied.

TROUBLE SHOOTING

1. Fault Diagnosis of the BGA (Ball Grid Array) IC

■ Overview

A flowchart for determining whether or not the transceiver can be powered on (**the Display does not function even if the power switch is turned on**) due to broken BGA parts.

■ BGA parts

ASIC (IC20), DSP (IC6), SRAM (IC9)

● Checking power supply voltage

Checking voltage	
Points to be checked	Normal voltage
33M IC303 (5 pin)	3.3V
16M IC305 (5 pin)	1.6V
15M IC304 (5 pin)	1.5V
33A IC306 (5 pin)	3.3V
33BU Q303 (Collector Side)	3.3V

Power supply of each device is connected through the coil.
[ASIC]
33M: L20 and L308, 15M: L309
[DSP]
33M: L4 and L308, 16M: R324
[SRAM]
33BU: L5

When an abnormal value is confirmed.

Checking for an abnormal point

33M has an abnormal voltage.
[ASIC]
Remove L20 to check the voltage of the 33M.
If the voltage becomes normal, the ASIC is broken.
[DSP]
Remove L4 to check the voltage of the 33M.
If the voltage becomes normal, the DSP is broken.

16M has an abnormal voltage.
[DSP]
Remove R324 to check the voltage of the 16M.
If the voltage becomes normal, the DSP is broken.

15M has an abnormal voltage.
[ASIC]
Remove L309 to check the voltage of the 15M.
If the voltage becomes normal, the ASIC is broken.

33A has an abnormal voltage.
[ASIC]
Remove L316 to check the voltage of the 33A.
If the voltage becomes normal, the ASIC is broken.

33BU has an abnormal voltage.
[SRAM]
Remove L5 to check the voltage of the 33BU.
If the voltage becomes normal, the SRAM is broken.

If the voltage is not corrected, there is a problem other than the BGA parts.

● Checking the clock

Checking the frequency and the magnitude voltage.	
Points to be checked	Normal Freq. and Magnitude
18.432MHz R115 (ASIC side)	18.432MHz 3.3V
R52 (DSP side)	18.432MHz 3.3V
32.768 kHz IC17 (1 pin)	32.768kHz 3.3V

When an abnormal value is confirmed.

[18.432MHz]
Remove the R115 and R52. If it oscillates normally, the DSP and ASIC may be broken.
[32.768kHz]
Exchange IC17(RTC). If it oscillates normally, the ASIC may be broken.

● Checking the Reset/Control signal

Checking the reset and control signal input to the ASIC	
Points to be checked	Normal voltage
RESET R511	3.3V
/BINT IC307 (1 pin)	3.3V
/OVRB Q301 (Collector side)	3.3V

When an abnormal value is confirmed.

The BGA parts are not broken.

Checking the ASIC input switch signal	
*Each signal is not masked by the setting of the FPU. The POWER key is pressed and held.	
Points to be checked	Confirmed voltage
/PSW R271 (ASIC Side)	0V

When an abnormal value is confirmed.

● Checking the output signal from the ASIC

Points to be checked	Normal voltage
/FRST IC3 (12 pin)	3.3V

When an abnormal value is confirmed.

If the /FRST is always 0V, the ASIC is broken.

When a normal value is confirmed.

TROUBLE SHOOTING

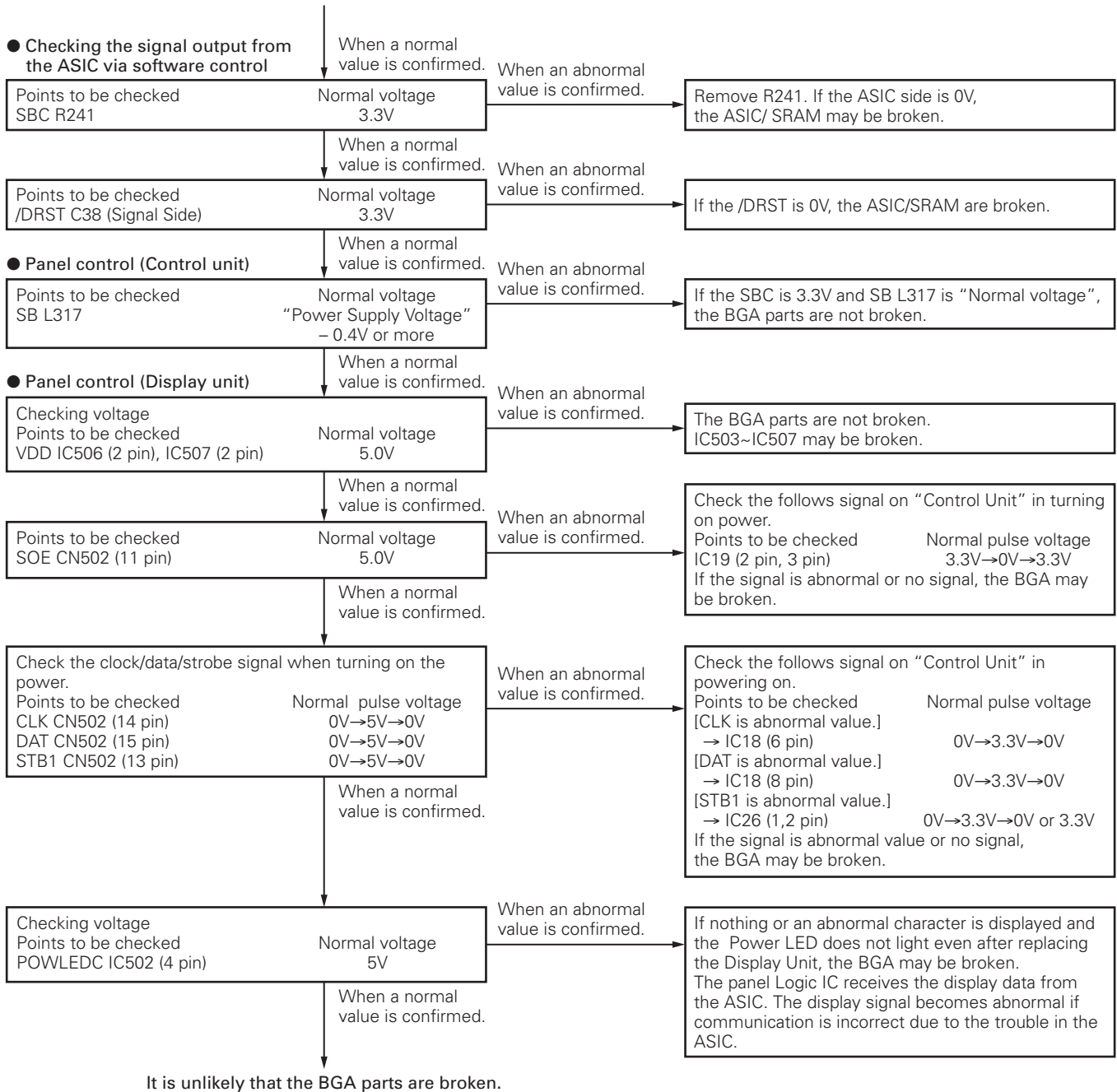

● **When an error display appears on the LED segment indicator.**

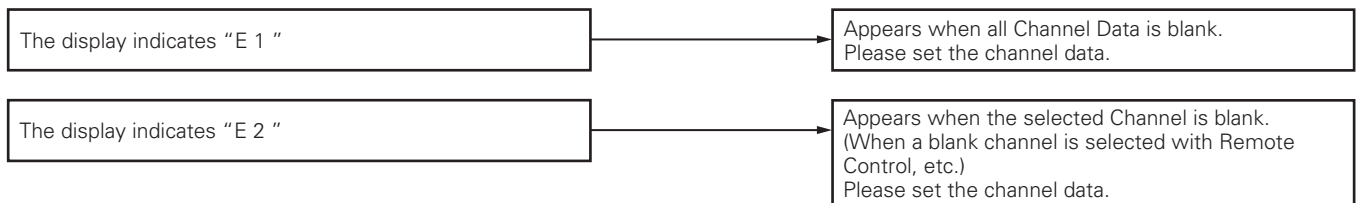

TROUBLE SHOOTING

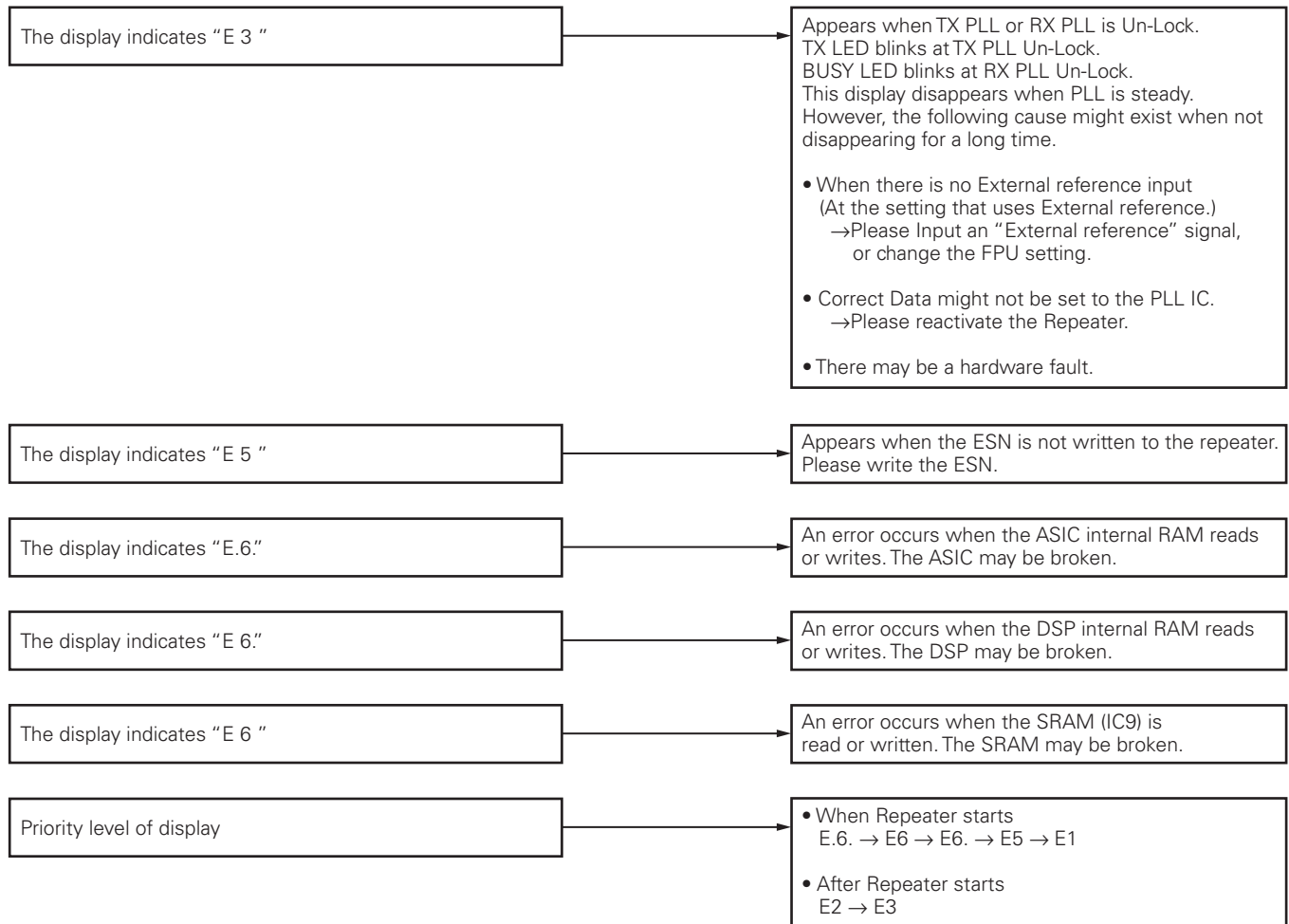

2. If normal power is not obtained, please follow the steps below

- Switch off the repeater.
The impedance of the Final FET (Q4) and Drive FET (Q3) can be measured easily using a DVM (Digital Volt Meter) ohm mode.
Normal condition – Gate: > 5kohm
The above impedance values are rough estimations.
- Switch on the repeater. Check the voltage at F1 output point.
The voltage is around 13.6V during reception.
The voltage will be 13.0V~ during transmission.
If this point measures 0V, then F1 is damaged.
- Remove C27.
- Connect a 50ohm load to the ANT terminal.
Transmit and check the current drain in High power mode.
If the current drain is less than 1.0A, then the Final FET is damaged.
If the current drain is less than 5.0A, short the Drive FET gate to ground, and check the current drain.
If the current drain is not 0.1A less than the original value, then the Drive FET is damaged.
- Check the input power level at the Drive FET gate location.
Connect the wire to [RF] location. (A join of R17 and R18)
Confirm that it is about 0.3W.
If power found is considerably lower than 0.3W, check the circuit before the Drive FET.

TROUBLE SHOOTING

■ Replacing the Final FET (Q4)

- 1) The X45 (final) PCB must be shifted to the left after placing it into the chassis.
Insert a board of just 1mm between the PCB and the case.
- 2) The FET (RD60HUF1-101) must be shifted to the right during mounting.

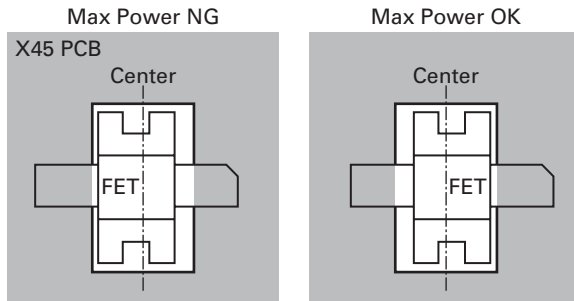

- 3) Apply solder to cover the entire FET terminal. (Both input and output terminals of the FET (Q3,Q4)).

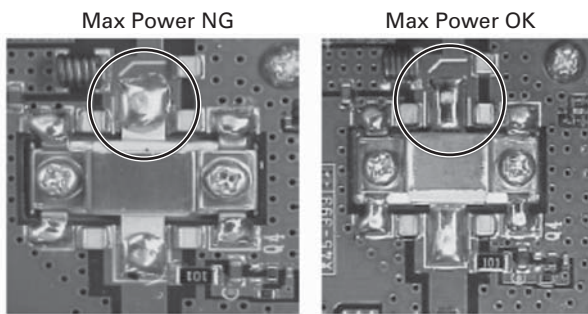

3. Replacing Control Unit

3-1. Control Unit Information

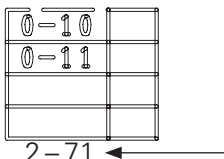
Original Control Unit	Control Unit (Service Unit)	Difference between Original Unit and Service Unit
X53-4580-10	X53-4582-71	As for the Service unit, "2-71" is stamped on the PCB. 

3-2. Supplied Accessories

Item (Including Part Number)	Quantity
Control Unit (X53-458)	1
KENWOOD ESN Label	3

3-3. Printed Circuit Board Data

The following data is written on the printed circuit board:

Data Type	Description
Firmware	TKR-D710/D810 Firmware
FPU Data (PC programming mode)	TKR-D710 E type data.
Various Adjustment Data (PC test mode)	General adjustment values for the TKR-D710.
KENWOOD ESN	Model Name: TKR-D710810S Type: E The same number as the KENWOOD ESN label is written.

3-4. After Changing the PCB

1. After changing the printed circuit board, write the up-to-date Firmware following the instructions in the "REALIGNMENT 4. Firmware Programming Mode".
2. Using the KPG-174D, select your desired item (Model Name and Frequency) from the Model > Product Information menu, then use Program > Write Data to the repeater to write the FPU data (PC Programming mode). When writing to the repeater, a Warning Message, corresponding to the item selected, appears. Click [OK] to continue writing the data.
3. Enter Program > Test mode, then adjust the various adjustment data (PC Test mode) as described in the "ADJUSTMENT".
4. For the X53-458, attach the new labels corresponding to the new printed circuit board. (Refer to the images on page 51 for label placement.)
5. If necessary, write the FPU data used by the customer with the KPG-174D.

Note:

- When a new printed circuit board is used, the KENWOOD ESN changes, as does the Repeater Information display of the KPG-174D, but this does not have any effect on the operation of the transceiver.
- If changing to the original KENWOOD ESN, please contact our service center.
- Re-installing other parts from original unit to Service unit is not required after changing to Service unit.

TROUBLE SHOOTING

3-5. ESN Label Layout

The following labels are provided in the service unit package.

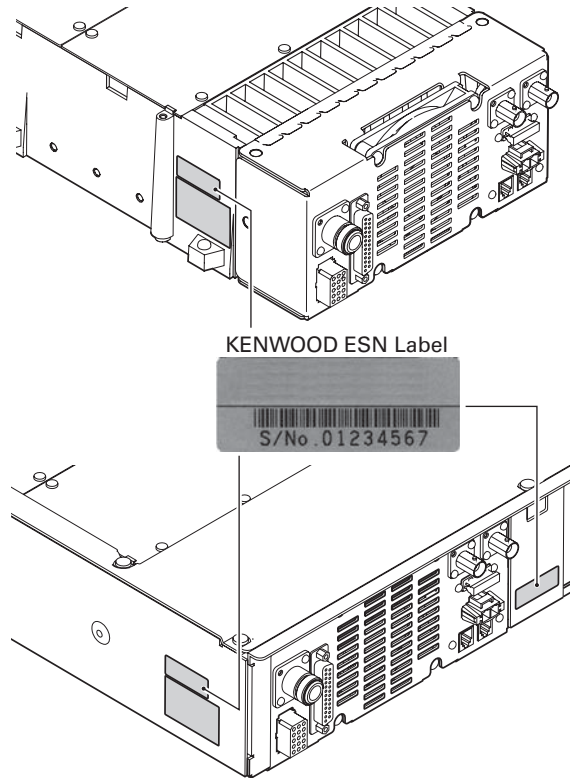
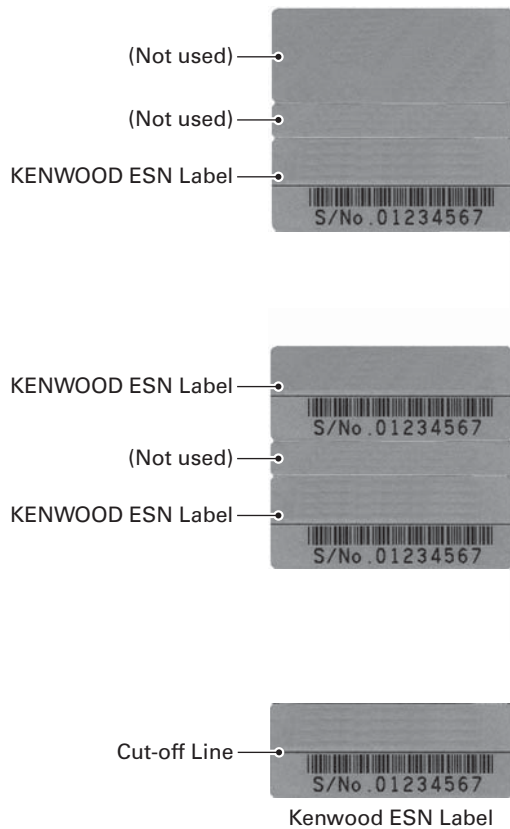

Note: For the X53-458, a UPC code and UPC barcode is not printed on the KENWOOD ESN Label. If necessary, cut the label at the cut-off line and attach only the serial number.

ADJUSTMENT

Test Equipment Required for Alignment

Test Equipment	Major Specifications
1. Standard Signal Generator (SSG)	Frequency Range 400 to 520MHz Modulation Frequency modulation and external modulation Output $-127\text{dBm}/0.1\mu\text{V}$ to greater than $-20\text{dBm}/22.4\text{mV}$ When performing the Frequency adjustment, the following accuracy is necessary. • 0.001ppm Use a standard oscillator for adjustments, if necessary.
2. Power Meter	Input Impedance 50Ω Operation Frequency 400 to 520MHz or more Measurement Capability Vicinity of 100W
3. Deviation Meter	Frequency Range 400 to 520MHz
4. Digital Volt Meter (DVM)	Measuring Range 1V to 20V DC Input Impedance High input impedance for minimum circuit loading
5. Oscilloscope	DC through 30MHz
6. High Sensitivity Frequency Counter	Frequency Range 10Hz to 600MHz Frequency Stability 0.2ppm or less
7. Ammeter	15A or more
8. AF Volt Meter (AF V.M)	Frequency Range 50Hz to 10kHz Voltage Range 3mV to 3V
9. Audio Generator (AG)	Frequency Range 50Hz to 5kHz Output 0 to 1V
10. Distortion Meter	Capability 3% or less at 1kHz Input Level 50mV to 10Vrms
11. Voltmeter	Measuring Range 10V to 1.5V DC or less Input Impedance $50\text{k}\Omega/\text{V}$ or greater
12. 4Ω Dummy Load	Approx. 4Ω , 5W

Test cable for microphone input (E30-3360-28)

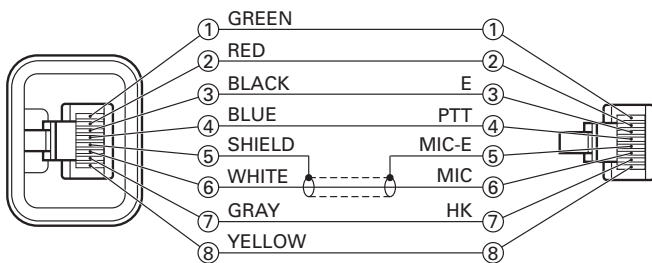

Tuning cable (E30-7754-05)

Adapter cable (E30-7754-05) is required for injecting an audio if PC tuning is used.

See "PC Mode" section for the connection.

Flat cable (36-pin) about 256mm

To connect the Control unit (CN38) to the TX-RX unit (CN800) while in servicing, you can use the 36-pin flat cable, E37-0979-05, which is available from the KENWOOD parts center.

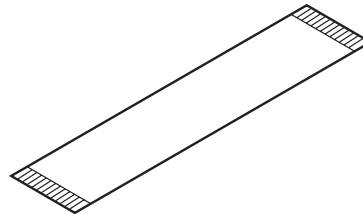

MIC connector (Front panel view)

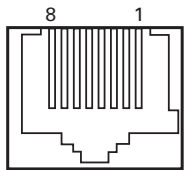

- 1: NC
- 2: SB
- 3: GND
- 4: PTT/TXD
(PC serial data from transceiver)
- 5: MIC GND
- 6: MIC
- 7: HOOK/RXD
(PC serial data to transceiver)
- 8: NC

ADJUSTMENT

Test Channel

No.	K		K2	
	RX (MHz)	TX (MHz)	RX (MHz)	TX (MHz)
1	485.050000	485.100000	435.050000	435.100000
2	450.050000	450.100000	400.050000	400.100000
3	519.950000	519.900000	469.950000	469.900000
4	485.000000	485.000000	435.000000	435.000000
5	485.200000	485.200000	435.200000	435.200000
6	485.400000	485.400000	435.400000	435.400000
7~16	-	-	-	-

Test Signaling (Analog)

No.	RX (Decode Signaling)	TX (Encode Signaling)
1	None	None
2	None	100Hz Square Wave
3	QT 67.0Hz	QT 67.0Hz
4	QT 151.4Hz	QT 151.4Hz
5	QT 210.7Hz	QT 210.7Hz
6	QT 254.1Hz	QT 254.1Hz
7	DQT D023N	DQT D023N
8	DQT D754I	DQT D754I
9	DTMF Decode (CODE: 159D)	DTMF Encode (CODE: 159D)
10	None	DTMF Encode (CODE: 9)
11	None	Test Tone Encode
12	None	Courtesy Tone
14	None	CW ID Encode (ID: VVV)

Test Signaling (DMR)

No.	RX (Decode Signaling)	TX (Encode Signaling)
1	CC00 Burst	CC00 Burst
2	None	PN 9 Continuous Pattern
3	None	Maximum Deviation Continuous Pattern
6	None	SYNC (Each Slot)+PN9 Burst Pattern

- Signaling number 1 is used for link test.
- Signaling number 2 is used for TX modulation signal quality test. i.e, TX adjacent channel power, FSK error, Occupied bandwidth, Emission mask, etc.
- Signaling number 3 is used for TX deviation test.

Adjustment Points

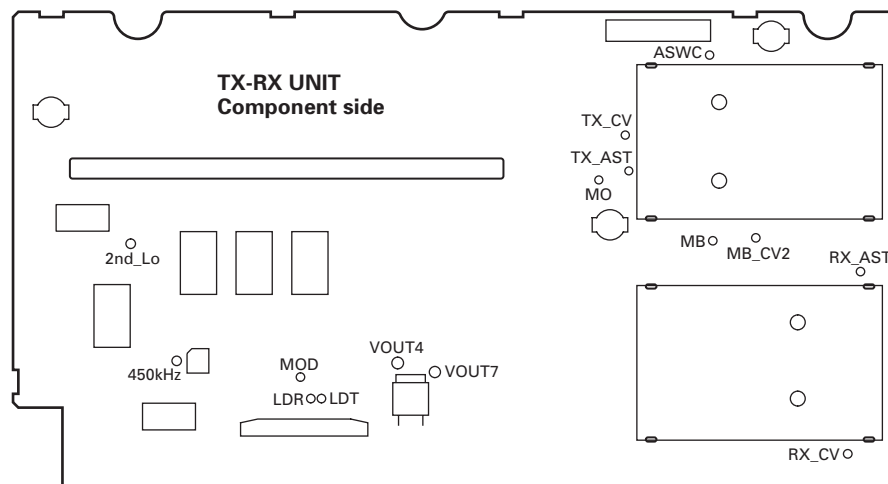

ADJUSTMENT

Common Section

Item	Condition	Measurement			Adjustment			Specifications / Remarks
		Test-equipment	Unit	Terminal	Unit	Parts	Method	
1. Setting	1) Connect the unit to a suitable power supply (13.6V). 2) Turn the power switch on after connecting a PC and FPU cable to the radio. 3) Start up the program for the adjustment.							
2. Receive Assist Adjust	FPU Test mode 1) Adjust Item: [Receive Assist] 2) Adjust Item: [A: Low], [A: Center], [A: High], [B: Low], [B: Center], [B: High]					PC ADJ	3.0V	±0.1V [V] indicator on the PC window shows "VCO lock voltage" Change the adjustment value to get "VCO lock voltage" within the limit of the specified voltage. Press [Apply All] button to store the adjustment value. Confirm the VCO lock voltage approximately 3 seconds after the adjustment value is changed.
	3) Adjust Item: [A: Low], [A: Center], [A: High], [B: Low], [B: Center], [B: High]	DVM	TX-RX	RX_CV			Check	3.0V±0.1V
3. Transmit Assist Adjust	FPU Test mode 1) Adjust Item: [Transmit Assist] 2) Adjust Item: [A: Low], [A: Center], [A: High], [B: Low], [B: Center], [B: High] Press [Transmit] button.					PC ADJ	3.0V	±0.1V [V] indicator on the PC window shows "VCO lock voltage" Change the adjustment value to get "VCO lock voltage" within the limit of the specified voltage. Press [Apply All] button to store the adjustment value. Confirm the VCO lock voltage approximately 3 seconds after the adjustment value is changed.
	3) Adjust Item: [A: Low], [A: Center], [A: High], [B: Low], [B: Center], [B: High] Press [Transmit] button.	DVM	TX-RX	TX_CV			Check	3.0V±0.1V
4. Sensitivity 1 Adjust	FPU Test mode 1) Adjust Item: [Sensitivity 1] 2) Adjust Item: [Low], [Low'], [Center], [High'], [High]					PC ADJ	Write the value as followings (typical value) [Low] = 20(K), 25(K2) [Low'] = 70(K), 70(K2) [Center] = 105(K), 103(K2) [High'] = 150(K), 145(K2) [High] = 210(K), 213(K2)	Press [Apply All] button to store the adjustment value. Variable-Capacitor Tune voltage is adjusted. (Output voltage is adjustment of BPF)

ADJUSTMENT

Item	Condition	Measurement			Adjustment			Specifications / Remarks
		Test-equipment	Unit	Terminal	Unit	Parts	Method	
5. Sensitivity 2 Adjust	FPU Test mode 1) Adjust Item: [Sensitivity 2] 2) Adjust Item: [Low], [Low'], [Center], [High'], [High]					PC ADJ	Write the value as followings (typical value) [Low] = 35(K), 25(K2) [Low'] = 70(K), 70(K2) [Center] = 110(K), 103(K2) [High'] = 150(K), 145(K2) [High] = 190(K), 213(K2)	Press [Apply All] button to store the adjustment value. Variable-Capacitor Tune voltage is adjusted. (Output voltage is adjustment of BPF)
6. RX Gain Adjustment [Analog Narrow]	FPU Test mode 1) Adjust Item: [RX Gain (Analog Narrow)] 2) Adjust Item: [Low], [Low'], [Center], [High'], [High]						Write the value as followings (typical value) [Low] = 1280 [Low'] = 1280 [Center] = 1280 [High'] = 1280 [High] = 1280	Press [Apply All] button to store the adjustment value.
7. RX Gain Adjustment [Analog Wide]	FPU Test mode 1) Adjust Item: [RX Gain (Analog Wide)] 2) Adjust Item: [Low], [Low'], [Center], [High'], [High]							
8. RX Gain Adjustment [DMR]	FPU Test mode 1) Adjust Item: [RX Gain (DMR Narrow)] 2) Adjust Item: [Low], [Low'], [Center], [High'], [High]							
9. Frequency Adjust	FPU Test mode 1) Adjust Item: [Frequency] Connect the SSG to the RX ANT. CH: 1 (Analog Narrow) SSG Output: -47dBm (1mV) (CW (without modulation)) Caution: Perform the frequency adjustment under the following condition. <ul style="list-style-type: none"> Temperature range of +23°C to +27°C (+73.4°F to +80.6°F). (The temperature is displayed on the frequency adjustment screen of the KPG-174D.) Use an accuracy of 0.001ppm for the SSG. (Use a standard oscillator if necessary.) 	SSG	Rear	RX ANT		PC ADJ		Press [Start] button of [Auto Tuning]. Press [Apply] Button to store the adjustment value after the automatic adjustment was finished.

ADJUSTMENT

Receiver Section

Item	Condition	Measurement			Adjustment			Specifications / Remarks		
		Test-equipment	Unit	Terminal	Unit	Parts	Method			
1. Open Squelch Adjust [Analog Wide]	FPU Test mode 1) Adjust Item: [Open Squelch (Analog Wide)] Connect the SSG to the RX ANT. SSG setting Frequency: [Low], [Low'] [Center], [High'], [High] Output : 12dB SINAD level -1dB MOD: 1.0kHz DEV: ±3.0kHz	SSG Audio analyzer Oscilloscope	Rear	RX ANT		PC ADJ		Press [Apply] button to store the adjustment value. Note: Write the fixed value of "33" when the adjustment value is 27 or less.		
					Check		The squelch shall be closed.			
2. SSG output: OFF										
2. Open Squelch Adjust [Analog Narrow]	FPU Test mode 1) Adjust Item: [Open Squelch (Analog Narrow)] Connect the SSG to the RX ANT. SSG setting Frequency: [Low], [Low'] [Center], [High'], [High] Output : 12dB SINAD level -1dB MOD: 1.0kHz DEV: ±1.5kHz							PC ADJ		Press [Apply] button to store the adjustment value. Note: Write the fixed value of "30" when the adjustment value is 24 or less.
									Check	The squelch shall be closed.
2) SSG output: OFF										
3. Tight Squelch Adjust [Analog Wide]	FPU Test mode 1) Adjust Item: [Tight Squelch (Analog Wide)] Connect the SSG to the RX ANT. SSG setting Frequency: [Low], [Low'] [Center], [High'], [High] Output : 12dB SINAD level +6dB MOD: 1.0kHz DEV: ±3.0kHz				PC ADJ		Press [Apply] button to store the adjustment value.			
						Check	The squelch shall be closed.			
2) SSG output: OFF										
4. Tight Squelch Adjust [Analog Narrow]	FPU Test mode 1) Adjust Item: [Tight Squelch (Analog Narrow)] Connect the SSG to the RX ANT. SSG setting Frequency: [Low], [Low'] [Center], [High'], [High] Output : 12dB SINAD level +6dB MOD: 1.0kHz DEV: ±1.5kHz				PC ADJ		Press [Apply] button to store the adjustment value.			
						Check	The squelch shall be closed.			
2) SSG output: OFF										

ADJUSTMENT

Item	Condition	Measurement			Adjustment			Specifications / Remarks
		Test-equipment	Unit	Terminal	Unit	Parts	Method	
5. Low RSSI Adjust [Analog Wide]	FPU Test mode 1) Adjust Item: [Low RSSI (Analog Wide)] Connect the SSG to the RX ANT. SSG setting Frequency: [Low], [Low'], [Center], [High'], [High] Output: -118dBm (0.28μV) MOD: 1.0kHz DEV: ±3.0kHz	SSG	Rear	RX ANT		PC ADJ		Press [Apply] button to store the adjustment value.
6. Low RSSI Adjust [Analog Narrow]	FPU Test mode 1) Adjust Item: [Low RSSI (Analog Narrow)] Connect the SSG to the RX ANT. SSG setting Frequency: [Low], [Low'], [Center], [High'], [High] Output: -118dBm (0.28μV) MOD: 1.0kHz DEV: ±1.5kHz							
7. High RSSI Adjust [Analog Wide]	FPU Test mode 1) Adjust Item: [High RSSI (Analog Wide)] Connect the SSG to the RX ANT. SSG setting Frequency: [Low], [Low'] [Center], [High'], [High] Output: -70dBm (70.7μV) MOD: 1.0kHz DEV: ±3.0kHz							Press [Apply] button to store the adjustment value.
8. High RSSI Adjust [Analog Narrow]	FPU Test mode 1) Adjust Item: [High RSSI (Analog Narrow)] Connect the SSG to the RX ANT. SSG setting Frequency: [Low], [Low'] [Center], [High'], [High] Output: -70dBm (70.7μV) MOD: 1.0kHz DEV: ±1.5kHz							
9. Receiver Sensitivity Check [Analog Wide]	1) Connect the SSG to the RX ANT. SSG setting Frequency: Desired Frequency Output: -53dBm (501μV) MOD: 1.0kHz DEV: ±3.0kHz AF: 0.45V/4Ω	SSG Audio analyzer	Rear	RX ANT			Check	-115dBm (0.4μV) or Less
[Analog Narrow]	2) SSG setting DEV: ±1.5kHz	Oscilloscope		TEST/ SPKR Jack pin 12 4Ω load				

ADJUSTMENT

Transmitter Section

Item	Condition	Measurement			Adjustment			Specifications / Remarks
		Test-equipment	Unit	Terminal	Unit	Parts	Method	
1. High Transmit Power Limit Adjust	FPU Test mode 1) Adjust Item: [High Transmit Power Limit] Frequency: [Low], [Low'], [Center], [High'], [High] Press [Transmit] button.	Power meter	Rear	TX ANT		PC ADJ	43W±1.5W	Press [Apply] button to store the adjustment value.
2. High Transmit Power Adjust	FPU Test mode 1) Adjust Item: [High Transmit Power] Frequency: [Low], [Low'], [Center], [High'], [High] Press [Transmit] button.						40W±0.5W	
3. Low Transmit Power Limit Adjust	FPU Test mode 1) Adjust Item: [Low Transmit Power Limit] Frequency: [Low], [Low'], [Center], [High'], [High] Press [Transmit] button.						28W±1.5W	
4. Low Transmit Power Adjust	FPU Test mode 1) Adjust Item: [Low Transmit Power] Frequency: [Low], [Low'], [Center], [High'], [High] Press [Transmit] button.						25W±0.5W	
5. RF Power Down Detection Adjust [High]	FPU Test mode 1) Adjust Item: [RF Power Down Detection (High)] Frequency: Desired Frequency Press [Transmit] button.						20W±0.5W	
6. RF Power Down Detection Adjust [Low]	FPU Test mode 1) Adjust Item: [RF Power Down Detection (Low)] Frequency: Desired Frequency Press [Transmit] button.						10W±0.5W	
7. Maximum Deviation Adjust [DMR Narrow]	FPU Test mode 1) Adjust Item: [Maximum Deviation (DMR Narrow)]					PC ADJ	Write the value as followings (typical value) [Maximum Deviation (DMR Narrow)] = 212	Press [Apply] button to store the adjustment value.
8. Maximum Deviation Adjust [Analog Wide]	FPU Test mode 1) Adjust Item: [Maximum Deviation (Analog Wide)]						Write the value as followings (typical value) [Maximum Deviation (Analog Wide)] = 212	
9. Maximum Deviation Adjust [Analog Narrow]	FPU Test mode 1) Adjust Item: [Maximum Deviation (Analog Narrow)]						Write the value as followings (typical value) [Maximum Deviation (Analog Narrow)] = 211	

ADJUSTMENT

Item	Condition	Measurement			Adjustment			Specifications / Remarks
		Test-equipment	Unit	Terminal	Unit	Parts	Method	
10. Balance Adjust [20Hz Adjustment]	FPU Test mode 1) Adjust Item: [Balance] Connect the Deviation Meter to the TX ANT end via the ATT. Deviation Meter setting LPF: 3kHz HPF: OFF De-emphasis: OFF 2) Adjust Item: [A: Low], [A: Center], [A: High], [B: Low], [B: Center], [B: High] Press [Transmit] button. 20Hz is transmitted.	Deviation meter Oscilloscope	Rear	TX ANT		PC ADJ	The Deviation of 20Hz frequency is fixed to 2.05kHz Deviation. Change the 2kHz adjustment value to become the same deviation to 20Hz within the specified range.	2kHz Tone deviation is within $\pm 1.0\%$ of 20Hz tone deviation. Press [Apply All] button to store the adjustment value after all adjustment point was adjusted.
[2.0kHz Adjustment]	FPU Test mode 1) Adjust Item: [Balance] [2kHz Sine Wave] check box is checked. 2) Adjust Item: [A: Low], [A: Center], [A: High], [B: Low], [B: Center], [B: High] Press [Transmit] button. Check while transmitting change to 2kHz.							
11. Standard Modulation Check [Analog Wide]	1) Connect the Deviation Meter to the TX ANT end via the ATT. Deviation Meter setting LPF: 15kHz HPF: OFF De-emphasis: OFF Detector: (p-p)/2 2) Connect the AG to the MIC Terminal of MIC connector. AG Frequency : 1kHz (Sine Wave) AG Output level: Adjust to become the 3kHz Deviation.	Deviation meter Oscilloscope AG DVM	Rear Front	TX ANT MIC			Check	5.0mV \pm 1.5mV
[Analog Narrow]	1) Connect the Deviation Meter to the TX ANT end via the ATT. Deviation Meter setting LPF: 15kHz HPF: OFF De-emphasis: OFF Detector: (p-p)/2 2) Connect the AG to the MIC Terminal of MIC connector. AG Frequency : 1kHz (Sine Wave) AG Output level: Adjust to become the 1.5kHz Deviation.							

ADJUSTMENT

Item	Condition	Measurement			Adjustment			Specifications / Remarks
		Test-equipment	Unit	Terminal	Unit	Parts	Method	
12. QT Deviation Adjust [Analog Wide]	FPU Test mode 1) Adjust Item: [QT Deviation (Analog Wide)] Connect the Deviation Meter to the TX ANT end via the ATT. Deviation Meter setting LPF: 3kHz, HPF: OFF De-emphasis: OFF Detector: p-p/2 Press [Transmit] button.	Deviation meter Oscilloscope	Rear	TX ANT		PC ADJ	0.75kHz Deviation	±0.05kHz Press [Apply] button to store the adjustment value.
13. QT Deviation Adjust [Analog Narrow]	FPU Test mode 1) Adjust Item: [QT Deviation (Analog Narrow)] Connect the Deviation Meter to the TX ANT end via the ATT. Deviation Meter setting LPF: 3kHz, HPF: OFF De-emphasis: OFF Detector: p-p/2 Press [Transmit] button.						0.35kHz Deviation	±0.05kHz Press [Apply] button to store the adjustment value.
14. DQT Deviation Adjust [Analog Wide]	FPU Test mode 1) Adjust Item: [DQT Deviation (Analog Wide)] Connect the Deviation Meter to the TX ANT end via the ATT. Deviation Meter setting LPF: 3kHz, HPF: OFF De-emphasis: OFF Detector: Peak hold Press [Transmit] button.						0.75kHz Deviation	±0.05kHz Press [Apply] button to store the adjustment value.
15. DQT Deviation Adjust [Analog Narrow]	FPU Test mode 1) Adjust Item: [DQT Deviation (Analog Narrow)] Connect the Deviation Meter to the TX ANT end via the ATT. Deviation Meter setting LPF: 3kHz, HPF: OFF De-emphasis: OFF Detector: Peak hold Press [Transmit] button.						0.35kHz Deviation	±0.05kHz Press [Apply] button to store the adjustment value.
16. DTMF Deviation Adjust [Analog Wide]	FPU Test mode 1) Adjust Item: [DTMF Deviation (Analog Wide)] Connect the Deviation Meter to the TX ANT end via the ATT. Deviation Meter setting LPF: 15kHz, HPF: OFF HPF: OFF De-emphasis: OFF Press [Transmit] button.						3.0kHz Deviation	±0.1kHz Press [Apply] button to store the adjustment value.
17. DTMF Deviation Adjust [Analog Narrow]	FPU Test mode 1) Adjust Item: [DTMF Deviation (Analog Narrow)] Connect the Deviation Meter to the TX ANT end via the ATT. Deviation Meter setting LPF: 15kHz, HPF: OFF De-emphasis: OFF Press [Transmit] button.						1.5kHz Deviation	±0.05kHz Press [Apply] button to store the adjustment value.

ADJUSTMENT

Item	Condition	Measurement			Adjustment			Specifications / Remarks
		Test-equipment	Unit	Terminal	Unit	Parts	Method	
18. Test Tone Deviation Adjust [Analog Wide]	FPU Test mode 1) Adjust Item: [Test Tone Deviation (Analog Wide)] Connect the Deviation Meter to the TX ANT end via the ATT. Deviation Meter setting LPF: 15kHz HPF: OFF De-emphasis: OFF Press [Transmit] button.	Deviation meter Oscilloscope	Rear	TX ANT		PC ADJ	3.0kHz Deviation	±0.1kHz Press [Apply] button to store the adjustment value.
19. Test Tone Deviation Adjust [Analog Narrow]	FPU Test mode 1) Adjust Item: [Test Tone Deviation (Analog Narrow)] Connect the Deviation Meter to the TX ANT end via the ATT. Deviation Meter setting LPF: 15kHz HPF: OFF De-emphasis: OFF Press [Transmit] button.						1.5kHz Deviation	±0.05kHz Press [Apply] button to store the adjustment value.
20. CW ID Deviation Adjust [Analog Wide]	FPU Test mode 1) Adjust Item: [CW ID Deviation (Analog Wide)] Connect the Deviation Meter to the TX ANT end via the ATT. Deviation Meter setting LPF: 15kHz HPF: OFF De-emphasis: OFF Press [Transmit] button.						2.0kHz Deviation	±0.1kHz Press [Apply] button to store the adjustment value.
21. CW ID Deviation Adjust [Analog Narrow]	FPU Test mode 1) Adjust Item: [CW ID Deviation (Analog Narrow)] Connect the Deviation Meter to the TX ANT end via the ATT. Deviation Meter setting LPF: 15kHz HPF: OFF De-emphasis: OFF Press [Transmit] button.						1.0kHz Deviation	±0.05kHz Press [Apply] button to store the adjustment value.
22. Courtesy Tone Deviation Adjust [Analog Wide]	FPU Test mode 1) Adjust Item: [Courtesy Tone Deviation (Analog Wide)] Connect the Deviation Meter to the TX ANT end via the ATT. Deviation Meter setting LPF: 15kHz HPF: OFF De-emphasis: OFF Press [Transmit] button.						1.0kHz Deviation	±0.05kHz Press [Apply] button to store the adjustment value.
23. Courtesy Tone Deviation Adjust [Analog Narrow]	FPU Test mode 1) Adjust Item: [Courtesy Tone Deviation (Analog Narrow)] Connect the Deviation Meter to the TX ANT end via the ATT. Deviation Meter setting LPF: 15kHz HPF: OFF De-emphasis: OFF Press [Transmit] button.						0.5kHz Deviation	±0.05kHz Press [Apply] button to store the adjustment value.

ADJUSTMENT

Item	Condition	Measurement			Adjustment			Specifications / Remarks
		Test-equipment	Unit	Terminal	Unit	Parts	Method	
24. Repeat Gain Adjust [Analog Wide]	FPU Test mode 1) Adjust Item: [Repeat Gain (Analog Wide)] Connect the Deviation Meter to the TX ANT end via the ATT. Deviation Meter setting LPF: 15kHz HPF: OFF De-emphasis: OFF 2) Connect the SSG to the RX ANT. SSG setting Frequency: Desired Frequency Output: -53dBm (501μV) MOD: 1.0kHz DEV: ±1.0kHz	Deviation meter Oscilloscope SSG	Rear	TX ANT RX ANT		PC ADJ	1.0kHz Deviation	±0.1kHz Press [Apply] button to store the adjustment value.
25. Repeat Gain Adjust [Analog Narrow]	FPU Test mode 1) Adjust Item: [Repeat Gain (Analog Narrow)] Connect the Deviation Meter to the TX ANT end via the ATT. Deviation Meter setting LPF: 15kHz HPF: OFF De-emphasis: OFF 2) Connect the SSG to the RX ANT. SSG setting Frequency: Desired Frequency Output: -53dBm (501μV) MOD: 1.0kHz DEV: ±1.0kHz							

Confirmation and Alignment of Set-up to Prevent Receiver Desensitization

1. Confirmation of Duplexer alignment

The duplexer allows the Repeater to simultaneously transmit and receive. To accomplish this, in the programmed receive frequency, the transmit frequency must be notched or suppressed by 75dB or more. Additionally, on the programmed transmit frequency, the receive frequency must be notched or suppressed by 75dB or more. The following figures are examples of Duplexer alignment using a spectrum analyzer.

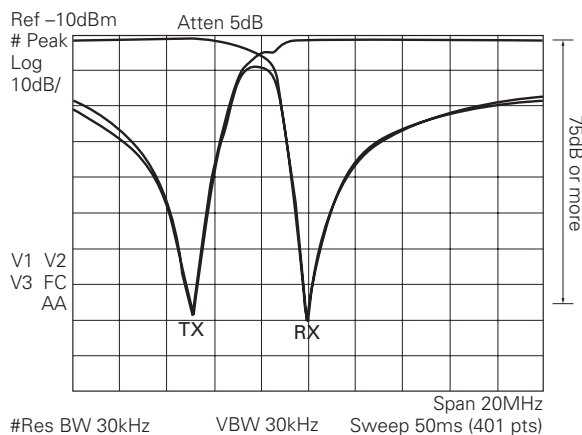

2. Confirmation of Repeater Desensitization

The following figure is a Test set-up for Repeater Desensitization.

After this Test set-up is completed, confirm the Repeater Desensitization as mentioned below.

- 1) Disable the repeater mode.
- 2) Adjust the level of the RF generator until 12dB SINAD is reached.
- 3) Increase the output of the RF generator by 1dB. (This increases the SINAD.)
- 4) Enable the repeater mode.
- 5) Read the SINAD level. It should not drop below 12dB SINAD. If the SINAD is less than 12dB, check the tightness of the connectors and the tuning of duplexer.

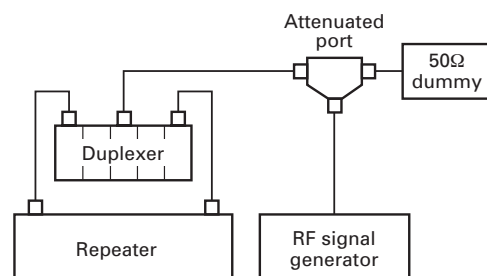

TERMINAL FUNCTION

Final Unit (X45-4020-XX) (A/3)

Pin No.	Name	I/O	Function
CN1 (To X57-897 CN610)			
1	TX IN	I	TX driver input signal (Coaxial)
CN201 (To X45-402 B/3 +B)			
1	+B	I	Power supply input
CN202 (To X45-402 B/3 GND)			
1	GND	-	Ground
CN203 (To X57-897 CN701)			
1	GND	-	Ground
2	+B	O	Power supply output
3	+B	O	Power supply output
CN204 (To X57-897 CN801)			
1	GND	-	Ground
2	8TC	I	8V power supply control
3	RAMP	I	RF power control voltage
4	ASWC	I	ANT switch control
5	FAN	I	FAN control
6	FDT	O	Coupler input voltage
7	TMP2	O	Temperature of X45 Final unit
8	TMP1	O	Temperature of X45 Final unit
9	PLIM	I	Power limit control
10	H/L	I	Power control
11	HVV2	O	Hardware version detect
CN205 (To FAN)			
1	FAB	O	FAN power supply
2	FAG	-	FAN ground

Final Unit (X45-4020-XX) (B/3)

Pin No.	Name	I/O	Function
+B (To X45-402 A/3 CN201)			
1	+B	O	Power supply output
GND (To X45-402 A/3 CN202)			
1	GND	-	Ground
+B1 (To MAIN DC)			
1	+B	I	Power supply input
GND (To MAIN DC)			
1	GND	-	Ground

Final Unit (X45-4020-XX) (C/3)

Pin No.	Name	I/O	Function
N_SYNC1, 2 (To X53-458 CN5)			
1	N_SYNC1_B	I/O	RS-485 differential signal 1-B
2	N_SYNC1_A	I/O	RS-485 differential signal 1-A
3	N_SYNC2_B	I/O	RS-485 differential signal 2-B
4	N_SYNC2_A	I/O	RS-485 differential signal 2-A
5	N_SYNC1_B	I/O	RS-485 differential signal 1-B
6	N_SYNC1_A	I/O	RS-485 differential signal 1-A
7	N_SYNC2_B	I/O	RS-485 differential signal 2-B
8	N_SYNC2_A	I/O	RS-485 differential signal 2-A
J401, 402 (N_SYNC1, 2 jack)			
1	N_SYNC2_A	I/O	RS-485 differential signal 2-A
2	N_SYNC2_B	I/O	RS-485 differential signal 2-B
3	N_SYNC1_A	I/O	RS-485 differential signal 1-A
4	N_SYNC1_B	I/O	RS-485 differential signal 1-B

Control Unit (X53-4580-10)

Pin No.	Name	I/O	Function
CN5 (To X45-402 C/3)			
1	N_SYNC1_B	I/O	RS-485 differential signal 1-B
2	N_SYNC1_A	I/O	RS-485 differential signal 1-A
3	N_SYNC2_B	I/O	RS-485 differential signal 2-B
4	N_SYNC2_A	I/O	RS-485 differential signal 2-A
5	N_SYNC1_B	I/O	RS-485 differential signal 1-B
6	N_SYNC1_A	I/O	RS-485 differential signal 1-A
7	N_SYNC2_B	I/O	RS-485 differential signal 2-B
8	N_SYNC2_A	I/O	RS-485 differential signal 2-A
CN38 (To X57-897 CN800)			
1	TMP1	I	Temperature of X45 Final unit
2	TMP2	I	Temperature of X45 Final unit
3	RAMP	O	RF power control voltage
4	FWD	I	RF power monitor voltage
5	TXASSIST	O	TX PLL assist voltage
6	RXASSIST	O	RX PLL assist voltage
7	TX_CV	I	TX VCO lock voltage
8	RX_CV	I	RX VCO lock voltage
9	GND	-	Ground
10	GND	-	Ground
11	TXVCOB	O	TX VCO B control signal
12	RXVCOA/B	O	RX VCO control signal to A or B
13	TXVCOA	O	TX VCO A control signal

TERMINAL FUNCTION

Pin No.	Name	I/O	Function
14	/RXPCS_TR	O	RX PLL chip select signal
15	LDT	I	TX PLL lock detect signal
16	/16_8PCS	O	Reference clock PLL chip select signal
17	LDR	I	RX PLL lock detect signal
18	/TXPCS	O	TX PLL chip select signal
19	SPSCLK0	O	Serial clock
20	SPSD0	O	Serial data
21	SBC	O	Switched +B control signal
22	GND	-	Ground
23	MOD	O	Audio signal for TX modulation
24	GND	-	Ground
25	RSSI	I	RSSI voltage
26	AGC	O	Auto gain control voltage
27	33A	O	3.3V voltage
28	/EWP	O	EEPROM write control signal
29	HVV1	I	Hardware version signal
30	I2CCK	O	Serial clock
31	SPSCLK1	O	Serial clock
32	I2CDA	I/O	Serial data
33	SPSD1	O	Serial data
34	/IOCS	I	IO expander chip select signal
35	/EVCS	O	DA converter chip select signal
36	NC	-	No connection
CN39			
IN	IF_SIG	I	450kHz IF signal
OUT	GND	-	Ground
CN40 (To X54-406 CN502)			
1	SB	O	Power supply input
2	SB	O	Power supply input
3	GND	-	Ground
4	NC	-	No connection
5	DAT	O	Serial data
6	PSW	I	Power switch signal
7	STB1	O	Data latch signal
8	CLK	O	Serial clock
9	SOE	O	Output enable signal
10	TXD1	I/O	MIC PTT, UART TX data
11	K1	I	Key scan input
12	RXD1	I	Hook detect signal, UART TX data
13	K2	I	Key scan input
14	K3	I	Key scan input

Pin No.	Name	I/O	Function
15	K4	O	Key scan output
16	K5	O	Key scan output
17	VLI	I	Speaker audio level control voltage
18	5C	O	5V voltage
19	MIG	-	MIC ground
20	MIC	I	MIC signal
CN41 (To TEST/SPKR 15pin Connector)			
1	SB	O	Power supply output
2	SB	O	Power supply input
3	GND	-	Ground
4	GND	-	Ground
CN42 (To TEST/SPKR 15pin Connector)			
1	AO5	O	Auxiliary output 5
2	AO4	O	Auxiliary output 4
3	AO3	O	Auxiliary output 3
4	SPO	O	Speaker AF output
5	SPO	O	Speaker AF output
6	AO2	O	Auxiliary output 2
7	AO1	O	Auxiliary output 1
8	SPI	I	Internal speaker AF input
9	RSI	O	RSSI voltage
10	NC	-	No connection
11	SPG	-	Speaker ground
12	SPG	-	Speaker ground
CN43 (To INT SPKR)			
1	SPO	O	Internal speaker AF output
2	SPG	-	Speaker ground
CN44 (To Control I/O 25pin D-sub Connector)			
1	NC	-	No connection
2	NC	-	No connection
3	SPM_D25	I	Speaker mute signal input
4	IO6_D25	I/O	Programmable function input/output 6
5	RXG	-	RX signal ground for RA,RD
6	IO5_D25	I/O	Programmable function input/output 5
7	NC	-	No connection
8	IO4_D25	I/O	Programmable function input/output 4
9	NC	-	No connection
10	IO3_D25	I/O	Programmable function input/output 3
11	NC	-	No connection
12	IO2_D25	I/O	Programmable function input/output 2
13	NC	-	No connection

TERMINAL FUNCTION

Pin No.	Name	I/O	Function
14	IO1_D25	I/O	Programmable function input/output 1
15	DG	-	Control line ground
16	TXG	-	TX signal ground for TA,TD
17	AI3_D25	I	Programmable function input 3
18	BER_DATA_D25	O	Bit error rate data
19	AI2_D25	I	Programmable function input 2
20	SC_D25	O	Squelch control output
21	AI1_D25	I	Programmable function input 1
22	NC	-	No connection
23	TXD0_D25	O	UART TX data
24	EXT_MON_D25	I	External monitor signal
25	RXD0_D25	I	UART RX data
26	BER_CLK_D25	O	Bit error rate clock
27	NC (RSSI)		No connection (RSSI)
28	NC	-	No connection
29	NC	-	No connection
30	NC	-	No connection
CN301 (To X57-897 CN700)			
1	GND	-	Ground
2	+B	I	Power supply input
3	SB	I	Power supply input

Display Unit (X54-4060-20) (A/2)

Pin No.	Name	I/O	Function
CN501 (To X54-406 B/2 CN601)			
1	HK	I	Hook detection input/ RXD input
2	MIC	I	MIC signal input
3	MIG	-	MIC ground
4	PTT	I/O	PTT input/TDX output
5	GND	-	Ground
6	NC	-	No connection
7	SB	O	Power supply output after power switch
8	NC	-	No connection
9	GND	-	Ground
10	5M	O	Common 5V output
11	VLI	I	Volume control input for AF signal
CN502 (To X53-458 CN40)			
1	MIG	-	MIC ground
2	MIC	O	MIC signal output
3	VLI	O	Volume control output for AF signal
4	5C	I	Common 5V output

Pin No.	Name	I/O	Function
5	K4	I	KEY input 4
6	K5	I	KEY input 5
7	K2	O	KEY input 2
8	K3	O	KEY input 3
9	K1	O	KEY input 1
10	HK/RXD	O	Hook detection output/ RXD input
11	SOE	I	Output enable for shift register
12	PTT/TXD	I/O	PTT output/TDX input
13	STB1	I	Strobe data for shift register
14	CLK	I	Clock data input
15	DAT	I	Serial data input
16	PSW	O	Power switch output
17	GND	-	Ground
18	NC	-	No connection
19	SB	I	Power supply output after power switch
20	SB	I	Power supply output after power switch

Display Unit (X54-4060-20) (B/2)

Pin No.	Name	I/O	Function
CN601 (To X54-406 A/2 CN501)			
1	VLI	O	Volume control output for AF signal
2	5M	I	Common 5V input
3	GND	-	Ground
4	NC	-	No connection
5	SB	I	Power supply output after power switch
6	NC	-	No connection
7	GND	-	Ground
8	PTT	I/O	PTT output/TDX input
9	MIG	-	MIC ground
10	MIC	O	MIC signal output
11	HK	O	Hook detection output/ RXD output
J601 (MIC jack)			
1	NC	-	No connection
2	SB	O	Power supply output after power switch
3	GND	-	Ground
4	PTT/TXD	I/O	PTT input/TDX output
5	MIG	-	MIC ground
6	MIC	I	MIC signal input
7	HOOK/RXD	I	Hook detection input/ RXD input
8	NC	-	No connection

TERMINAL FUNCTION

TX-RX Unit (X57-897K-XX)

Pin No.	Name	I/O	Function
CN101 (To RX ANT)			
1	RX_SIGNAL	I	Receive signal input (Coaxial)
CN202 (To X58-521 CN350)			
1	GND	-	Ground
2	NC	-	No connection
3	80C_2	O	8V power supply
4	RXVCOA/B	O	VCO select
5	RX_CV	I	Control voltage input
6	NC	-	No connection
7	RXASSIST	O	Assist voltage output
CN203 (To X58-521 CN351)			
1	VO	I	VCO input
2	GND	-	Ground
CN204 (To X58-521 CN303)			
1	FIN	O	VCO output
2	SPSCLK0	O	PLL clock output
3	/RXPCS_TR	O	PLL chip select output
4	SPSD0	O	PLL data output
5	33C	O	3.3V power supply
6	50C	O	5V power supply
7	LDR	I	PLL lock detect input
8	REF	O	19.2MHz reference clock output
CN500 (To Ext IN)			
1	REF IN	I	External reference input (Coaxial)
CN605 (To X58-522 CN350)			
1	GND	-	Ground
2	TXVCOB	O	VCOB select
3	80C_1	O	8V power supply
4	TXVCOA	O	VCOA select
5	TX_CV	I	Control voltage input
6	MO	O	Modulation output
7	TXASSIST	O	Assist voltage output
CN608 (To X58-522 CN351)			
1	VO	I	VCO input
2	GND	-	Ground
CN609 (To X58-522 CN303)			
1	FIN	O	VCO output
2	SPSCLK0	O	PLL clock output
3	/TXPCS	O	PLL chip select output
4	SPSD0	O	PLL data output

Pin No.	Name	I/O	Function
5	33C	O	3.3V power supply
6	50C	O	5V power supply
7	LDT	I	PLL lock detect input
8	REF	O	16.8MHz reference clock output
CN610 (To X45-402 A/3 CN1)			
1	TX OUT	O	TX driver output signal (Coaxial)
CN700 (To X53-458 CN301)			
1	GND	-	Ground
2	+B	O	Power supply output
3	SB	O	Power supply output
CN701 (To X45-402 A/3 CN203)			
1	GND	-	Ground
2	+B	I	Power supply input
3	+B	I	Power supply input
CN800 (To X53-458 CN38)			
1	NC	-	No connection
2	/EVCS	I	DA converter chip select signal
3	/IOCS	O	IO expander chip select signal
4	SPSD1	I	Serial data
5	I2CDA	I/O	Serial data
6	SPSCLK1	I	Serial clock
7	I2CCK	I	Serial clock
8	HWW1	O	Hardware version signal
9	/EWP	I	EEPROM write control signal
10	33A	I	3.3V voltage
11	AGC	I	Auto gain control voltage
12	RSSI	O	RSSI voltage
13	GND	-	Ground
14	MOD	I	Audio signal for TX modulation
15	GND	-	Ground
16	SBC	I	Switched +B control signal
17	SPSD0	I	Serial data
18	SPSCLK0	I	Serial clock
19	/TXPCS	I	TX PLL chip select signal
20	LDR	O	RX PLL lock detect signal
21	/16_8PCS	I	Reference clock PLL chip select signal
22	LDT	O	TX PLL lock detect signal
23	/RXPCS_TR	I	RX PLL chip select signal
24	TXVCOA	I	TX VCO A control signal
25	RXVCOA/B	I	RX VCO control signal to A or B
26	TXVCOB	I	TX VCO B control signal

TERMINAL FUNCTION

Pin No.	Name	I/O	Function
27	GND	-	Ground
28	GND	-	Ground
29	RX_CV	O	RX VCO lock voltage
30	TX_CV	O	TX VCO lock voltage
31	RXASSIST	I	RX PLL assist voltage
32	TXASSIST	I	TX PLL assist voltage
33	FWD	O	RF power monitor voltage
34	RAMP	I	RF power control voltage
35	TMP2	O	Temperature of X45 Final unit
36	TMP1	O	Temperature of X45 Final unit
CN801 (To X45-402 A/3 CN204)			
1	HVV2	I	Hardware version detect
2	H/L	O	Power control
3	PLIM	O	Power limit control
4	TMP1	I	Temperature of X45 Final unit
5	TMP2	I	Temperature of X45 Final unit
6	FDT	I	Coupler input voltage
7	FAN	O	FAN control
8	ASWC	O	ANT switch control
9	RAMP	O	RF power control voltage
10	8TC	O	8V power supply control
11	GND	-	Ground
CN802 (To X53-458 CN39)			
1	IF_SIG	O	450kHz IF signal (Coaxial)

RX VCO/PLL Unit (X58-5210-XX)

Pin No.	Name	I/O	Function
CN303 (To X57-897 CN204)			
1	FIN	I	VCO input
2	SPSCLK0	I	PLL clock input
3	/RXPCS_TR	I	PLL chip select input
4	SPSD0	I	PLL data input
5	33C	I	3.3V power supply
6	50C	I	5V power supply
7	LDR	O	PLL Lock detect output
8	REF	I	19.2MHz reference clock input

Pin No.	Name	I/O	Function
CN350 (To X57-897 CN202)			
1	GND	-	Ground
2	NC	-	No connection
3	80C_2	I	8V power supply
4	RXVCOA/B	I	VCO select
5	RX_CV	O	Control voltage output
6	NC	-	No connection
7	RXASSIST	I	Assist voltage input
CN351 (To X57-897 CN203)			
1	VO	O	VCO output
2	GND	-	Ground

TX VCO/PLL Unit (X58-5220-XX)

Pin No.	Name	I/O	Function
CN303 (To X57-897 CN609)			
1	FIN	I	VCO input
2	SPSCLK0	I	PLL clock input
3	/TXPCS	I	PLL chip select input
4	SPSD0	I	PLL data input
5	33C	I	3.3V power supply
6	50C	I	5V power supply
7	LDT	O	PLL lock detect output
8	REF	I	16.8MHz reference clock input
CN350 (To X57-897 CN605)			
1	GND	-	Ground
2	TXVCOB	I	VCOB select
3	80C_1	I	8V power supply
4	TXVCOA	I	VCOA select
5	TX_CV	O	Control voltage output
6	MO	I	Modulation input
7	TXASSIST	I	Assist voltage input
CN351 (To X57-897 CN608)			
1	VO	O	VCO output
2	GND	-	Ground

TERMINAL FUNCTION

CONTROL I/O 25 pin D-sub Connector

Pin No	Pin Name	I/O	Signal Type	Signal Summary	Specification	Min	Typ	Max	Unit	Remarks
1	NC (RSSI)	-	-	-	-	-	-	-	-	
2	RXD 2	I	Digital	Asynchronous Receive Data	-	-15	-	+15	V	conform to RS-232C
3	TXD 2	O	Digital	Asynchronous Send Data	-	±5.0	±9.0		V	RL=3kΩ conform to RS-232C
4	AI1	I	Digital	Programmable Function Input 1 /CMOS	VIH	0.8Vcc		Vcc	V	Vcc=5V±2%
					VIL	VSS		0.2Vcc	V	
					Input impedance		47k		Ohm	47k ohm PU to Vcc
5	AI2	I	Digital	Programmable Function Input 2 /CMOS	VIH	0.8Vcc		Vcc	V	Vcc=5V±2%
					VIL	VSS		0.2Vcc	V	
					Input impedance		47k		Ohm	47k ohm PU to Vcc
6	AI3	I	Digital	Programmable Function Input 3 /CMOS	VIH	0.8Vcc		Vcc	V	Vcc=5V±2%
					VIL	VSS		0.2Vcc	V	
					Input impedance		47k		Ohm	47k ohm PU to Vcc
7	DG	-	GND	Digital GND	-	-	-	-	-	
8	TD	-	-	Non-use	-	-	-	-	-	
9	TA	-	-	Non-use	-	-	-	-	-	
10	RD	-	-	Non-use	-	-	-	-	-	
11	RA	-	-	Non-use	-	-	-	-	-	
12	RXG	-	GND	RX Signal GND	-	-	-	-	-	
13	SPM	I	Digital	Speaker Mute /CMOS	VIH	0.7Vcc1	-	5.5	V	Vcc1=3.3V±2%
					VIL	-	-	0.3Vcc1	V	
					Input impedance		47k		Ohm	
14	BER_CLK	O	Digital	for Bit Error Rate Clock	VOH (IO=-20μA)	4.4	4.5		V	47k ohm PU to Vcc
					VOL (IO=20μA)		0	0.1	V	
15	EMON	-	-	Non-use	-	-	-	-	-	
16	EPTT	-	-	Non-use	-	-	-	-	-	
17	SC	O	Digital	Squelch Control /CMOS	VOH (IO=-0.5mA)	4.4	4.5	4.6	V	47k ohm PU to Vcc
					VOL (IO=0.5mA)			1.1	V	
18	BER_DAT	O	Digital	for Bit Error Rate Data	VOH (IO=-20μA)	4.4	4.5		V	
					VOL (IO=20μA)		0	0.1	V	

TERMINAL FUNCTION

Pin No	Pin Name	I/O	Signal Type	Signal Summary	Specification	Min	Typ	Max	Unit	Remarks
19	TXG	-	GND	TX Signal GND	-	-	-	-	-	
20	IO1	I	Digital	Programmable Function I/O 1	VIH	0.8Vcc		Vcc	V	Vcc=5V±2%
					VIL	VSS		0.2Vcc	V	
		O			Input impedance		47k		Ohm	47k ohm PU to Vcc
					VOH (IO=-0.5mA)	4.4	4.5	4.6	V	
					VOL (IO=0.5mA)			1.1	V	
21	IO2	I	Digital	Programmable Function I/O 2	VIH	0.8Vcc		Vcc	V	Vcc=5V±2%
					VIL	VSS		0.2Vcc	V	
		O			Input impedance		47k		Ohm	47k ohm PU to Vcc
					VOH (IO=-0.5mA)	4.4	4.5	4.6	V	
					VOL (IO=0.5mA)			1.1	V	
22	IO3	I	Digital	Programmable Function I/O 3	VIH	0.8Vcc		Vcc	V	Vcc=5V±2%
					VIL	VSS		0.2Vcc	V	
		O			Input impedance		47k		Ohm	47k ohm PU to Vcc
					VOH (IO=-0.5mA)	4.4	4.5	4.6	V	
					VOL (IO=0.5mA)			1.1	V	
23	IO4	I	Digital	Programmable Function I/O 4	VIH	0.8Vcc		Vcc	V	Vcc=5V±2%
					VIL	VSS		0.2Vcc	V	
		O			Input impedance		47k		Ohm	47k ohm PU to Vcc
					VOH (IO=-0.5mA)	4.4	4.5	4.6	V	
					VOL (IO=0.5mA)			1.1	V	
24	IO5	I	Digital	Programmable Function I/O 5	VIH	0.8Vcc		Vcc	V	Vcc=5V±2%
					VIL	VSS		0.2Vcc	V	
		O			Input impedance		47kΩ		V	47k ohm PU to Vcc
					VOH (IO=-0.5mA)	4.4	4.5	4.6	V	
					VOL (IO=0.5mA)			1.1	V	
25	IO6	I	Digital	Programmable Function I/O 6	VIH	0.8Vcc		Vcc	V	Vcc=5V±2%
					VIL	VSS		0.2Vcc	V	
		O			Input impedance		47kΩ		V	47k ohm PU to Vcc
					VOH (IO=-0.5mA)	4.4	4.5	4.6	V	
					VOL (IO=0.5mA)			1.1	V	

TERMINAL FUNCTION

TEST/SPKR 15 pin Connector

Pin No.	Pin Name	I/O	Signal Type	Configuration Change	Signal Summary	Specification	Min	Typ	Max	Unit	Remarks
1	SB	-	-	No	Power Supply	Voltage value	10.8	13.6	15.6	V	
						Supply current			1	A	
2	SB	-	-	No	Power Supply	Voltage value	10.8	13.6	15.6	V	
						Supply current			1	A	
3	NC	-	-	-	-	-					
4	GND	-	GND	No	Digital GND						
5	GND	-	GND	No	Digital GND						
6	SPG	-	GND	No	Speaker GND						
7	RD	-	-	-	Non-use	-	-	-	-	-	
8	RSSI	O	Analog	No	RSSI Output	Amplitude value	0		3.3	V	
						Allowable Load value	10k			Ohm	
9	SPI	I	Analog	No	Internal Speaker Input		-	-	-		
10	AO1	O	Digital	default	Auxiliary Output 1 Open collector	External voltage value			16	V	
						Supply current			200	mA	
				R203	Auxiliary Output 1 Open collector with PU	PU resistor	4.7k	47k		Ohm	Vcc=5V±2%
						VOL (IO=0mA)			0.1	V	
11	AO2	O	Digital	default	Auxiliary Output 2 Open collector	External Voltage value			16	V	
						Supply current			200	mA	
				R202	Auxiliary Output 2 Open collector with PU	PU resistor	4.7k	47k		Ohm	Vcc=5V±2%
						VOL (IO=0mA)			0.1	V	
12	SPO	O	Analog	No	External Speaker Output	Output level			4	W	
13	AO3	O	Digital	default	Auxiliary Output 3 Open collector	External voltage value			16	V	
						Supply current			200	mA	
				R201	Auxiliary Output 3 Open collector with PU	PU resistor	4.7k	47k		Ohm	Vcc=5V±2%
						VOL (IO=0mA)			0.1	V	
14	AO4	O	Digital	default	Auxiliary Output 4 Open collector	External voltage value			16	V	
						Supply current			200	mA	
				R200	Auxiliary Output 4 Open collector with PU	PU resistor	4.7k	47k		Ohm	Vcc=5V±2%
						VOL (IO=0mA)			0.1	V	
15	AO5	O	Digital	default	Auxiliary Output 5 Open collector	External voltage value			16	V	
						Supply current			200	mA	
				R198	Auxiliary Output 5 Open collector with PU	PU resistor	4.7k	47k		Ohm	Vcc=5V±2%
						VOL (IO=0mA)			0.1	V	

MEMO

TKR-D810 PC BOARD

FINAL UNIT (X45-4020-10(TKR-D810K2),X45-4020-11(TKR-D810K))
Component side view (J79-0264-19)

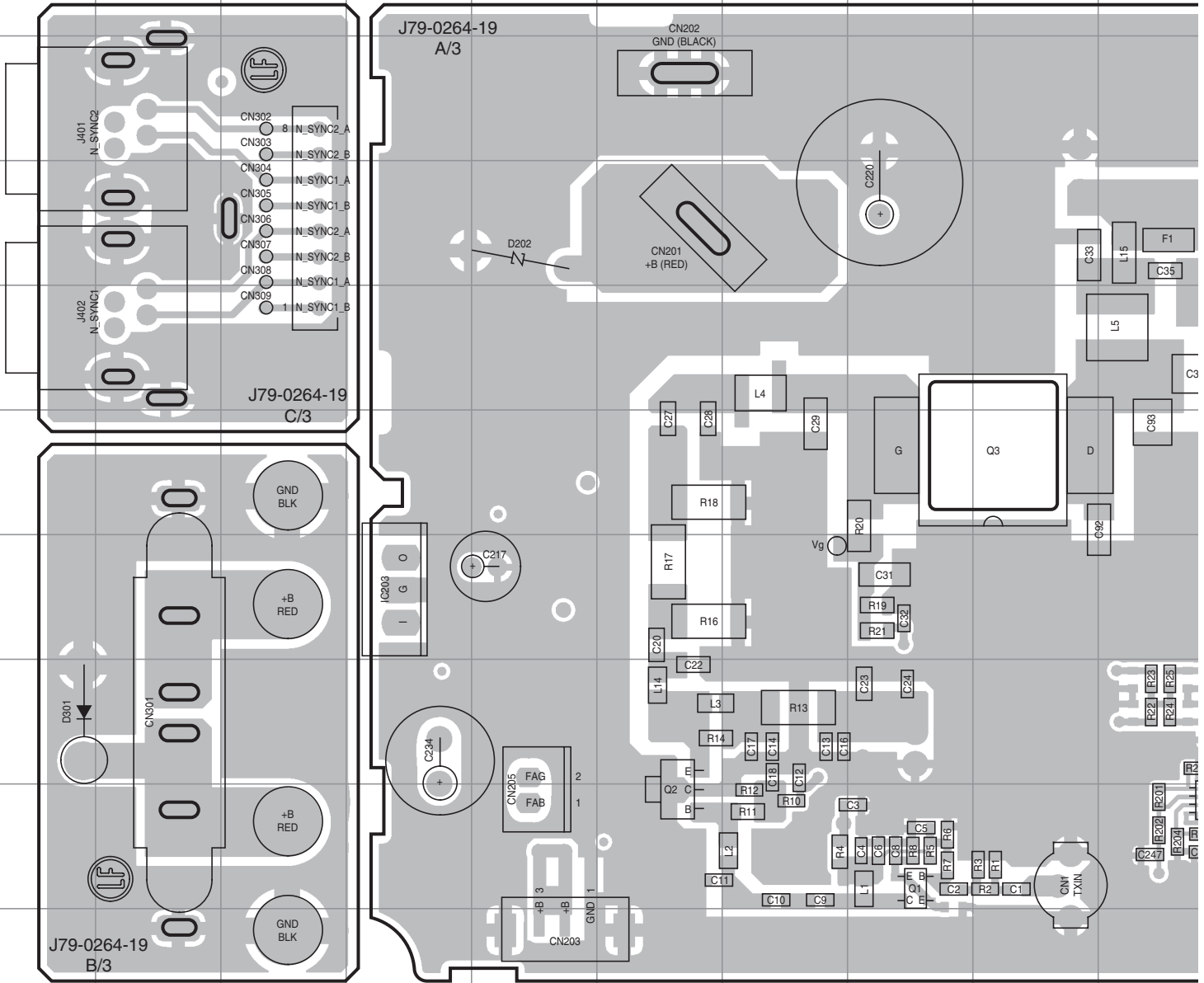

Ref. No.	Address	Ref. No.	Address
IC201	9J	D1	8Q
IC202	8L	D2	8M
IC203	7D	D3	9Q
Q1	9H	D8	4Q
Q2	9F	D201	8K
Q3	6I	D202	4E
Q4	5L	D301	8A

PC BOARD TKR-D810

FINAL UNIT (X45-4020-10(TKR-D810K2),X45-4020-11(TKR-D810K))
Component side view (J79-0264-19)

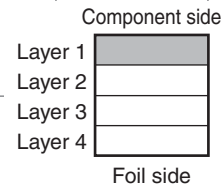
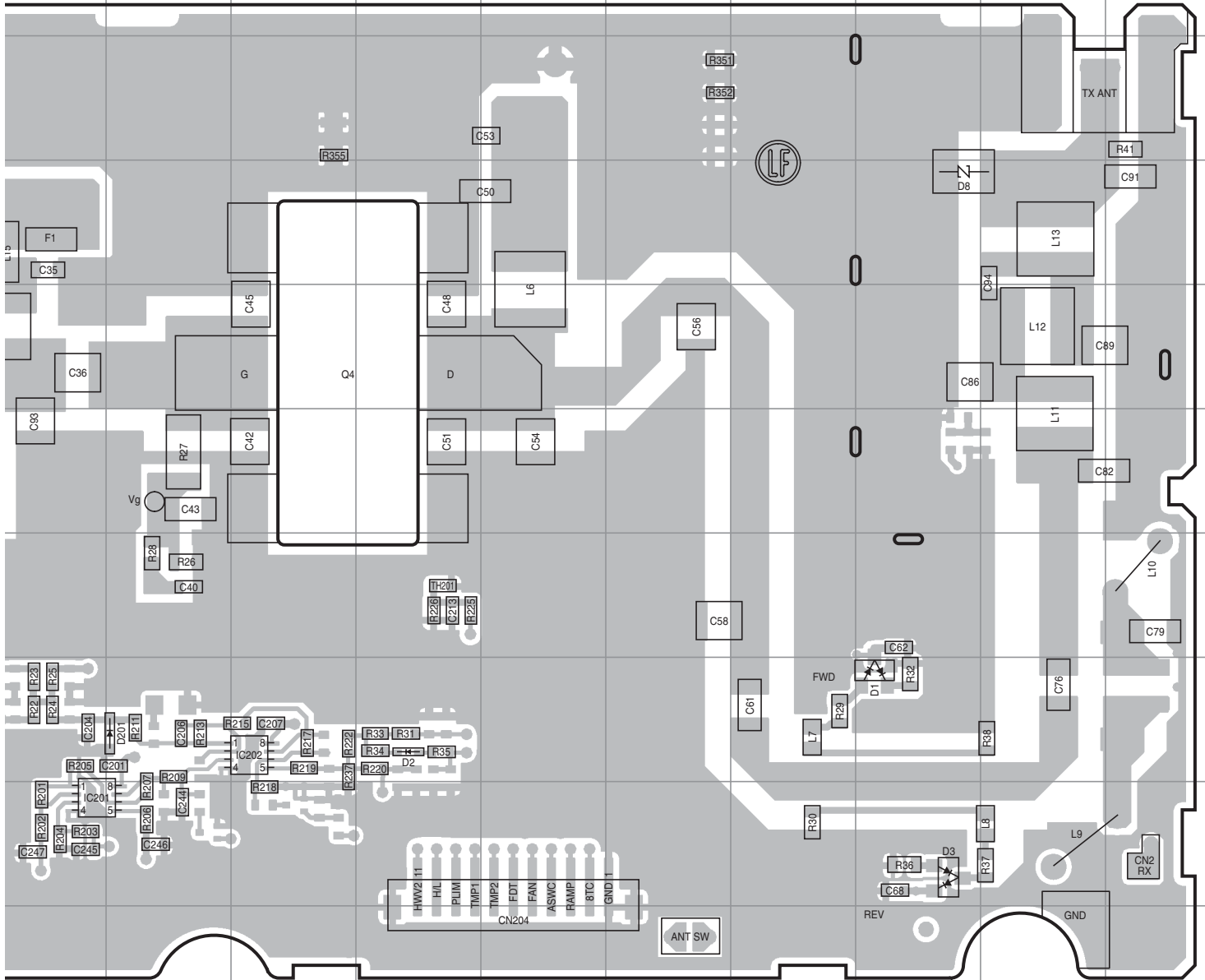

TKR-D810 PC BOARD

FINAL UNIT (X45-4020-10(TKR-D810K2),X45-4020-11(TKR-D810K))
Foil side view (J79-0264-19)

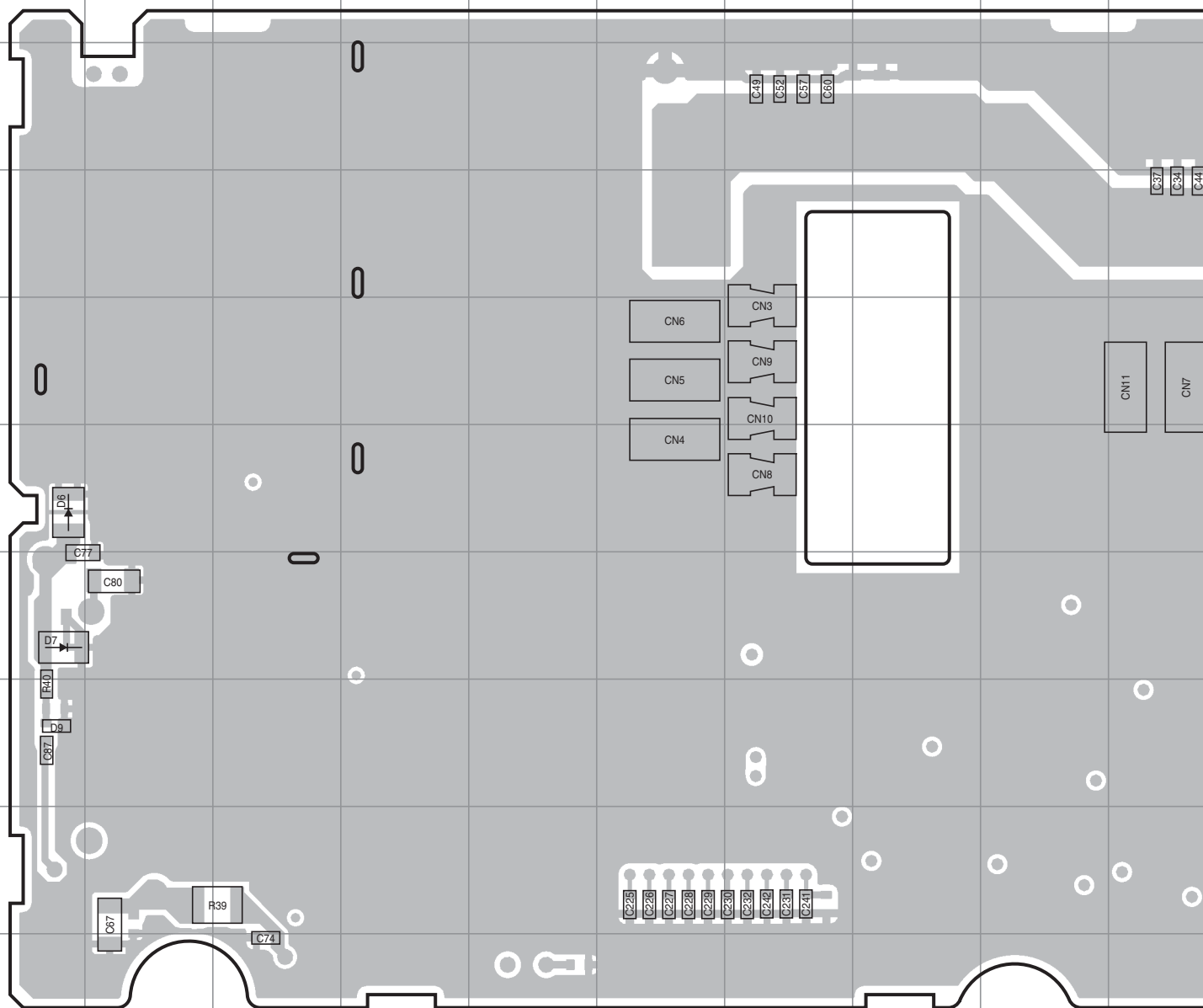

Ref. No.	Address
Q203	7O
Q204	6O
Q205	7P
Q206	6P
Q207	9O
D6	6A
D7	7A
D203	9O

PC BOARD TKR-D810

FINAL UNIT (X45-4020-10(TKR-D810K2),X45-4020-11(TKR-D810K))
Foil side view (J79-0264-19)

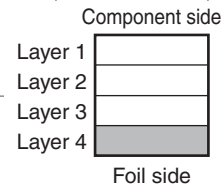
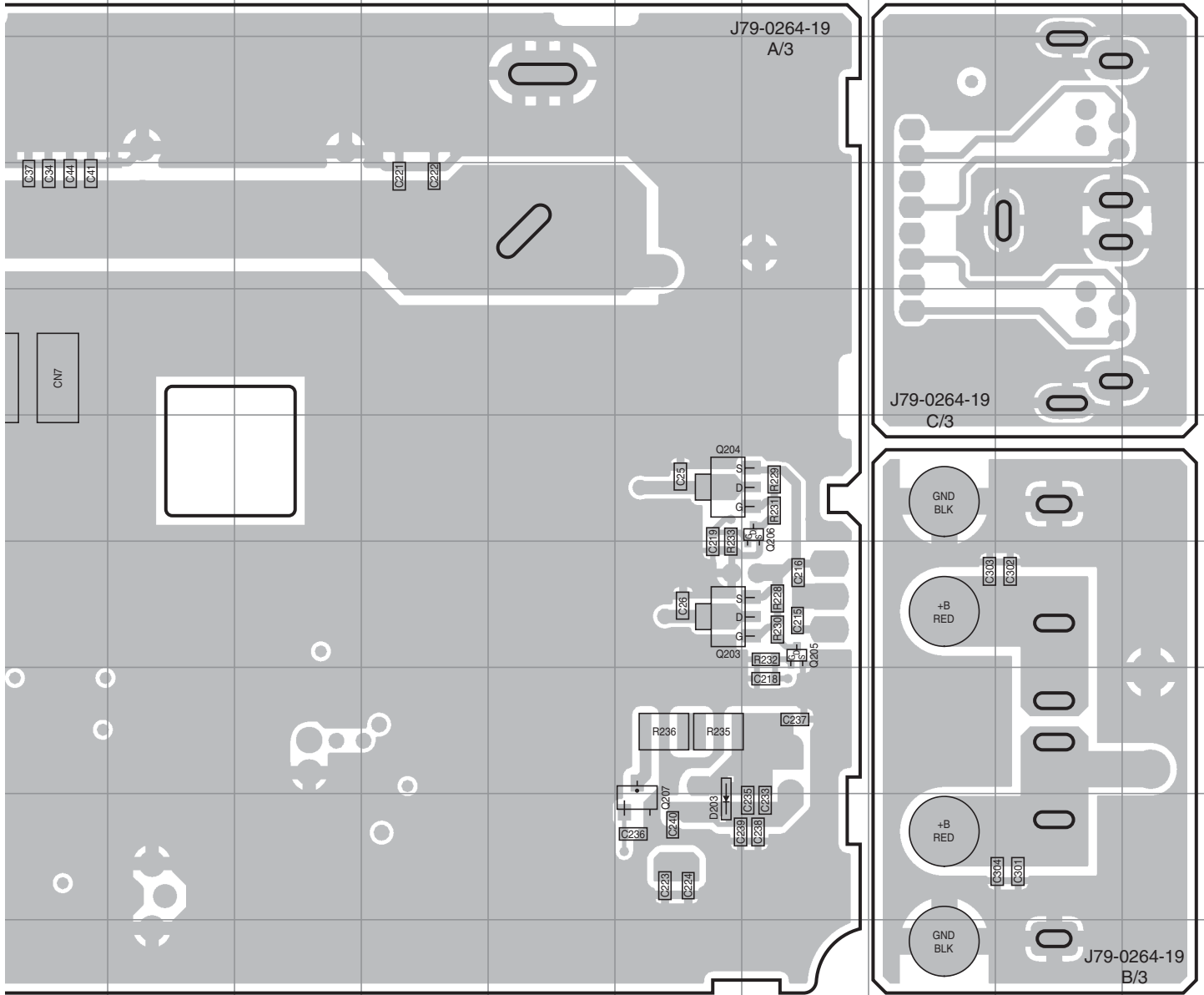

TKR-D810 PC BOARD

CONTROL UNIT (X53-4580-10) Component side view (J79-0277-19)

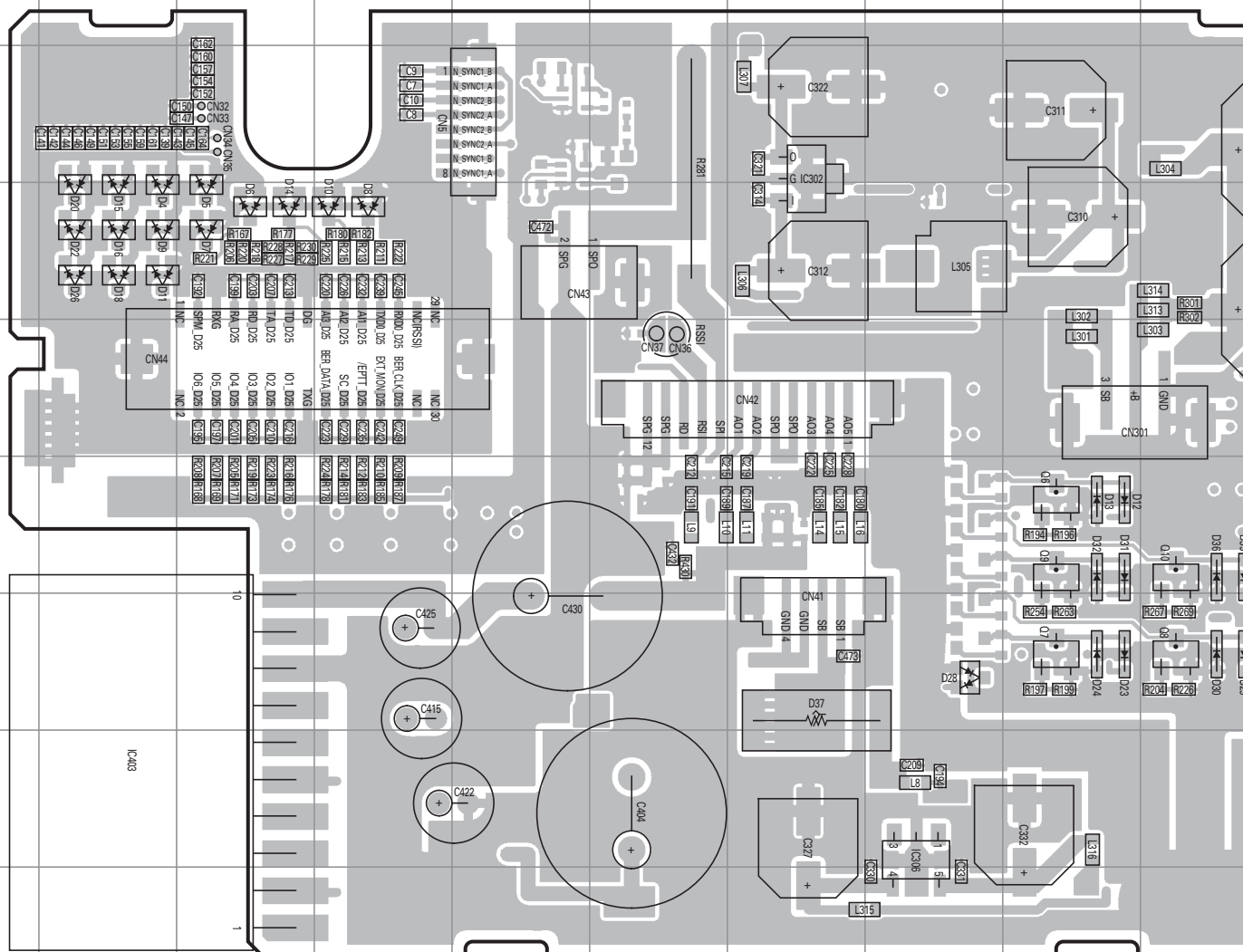

Ref. No.	Address	Ref. No.	Address	Ref. No.	Address	Ref. No.	Address	Ref. No.	Address
IC25	8N	Q6	6I	D7	4C	D18	4B	D32	6I
IC26	8N	Q7	7I	D8	4D	D20	4B	D35	6J
IC27	8M	Q8	7J	D9	4B	D22	4B	D36	6J
IC28	8M	Q9	6I	D10	4D	D23	7I	D37	7G
IC302	3G	Q10	6J	D11	4B	D24	7I	D302	4N
IC303	4M	Q302	5L	D12	6I	D26	4B	D304	5L
IC304	4N	Q303	5L	D13	6I	D28	7H	D305	5L
IC305	4R	D4	4B	D14	4C	D29	7J		
IC306	8H	D5	4C	D15	4B	D30	7J		
IC403	8B	D6	4C	D16	4B	D31	6I		

PC BOARD TKR-D810

CONTROL UNIT (X53-4580-10)
Component side view (J79-0277-19)

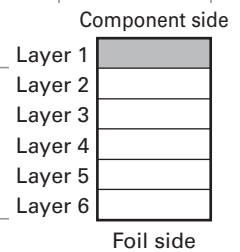
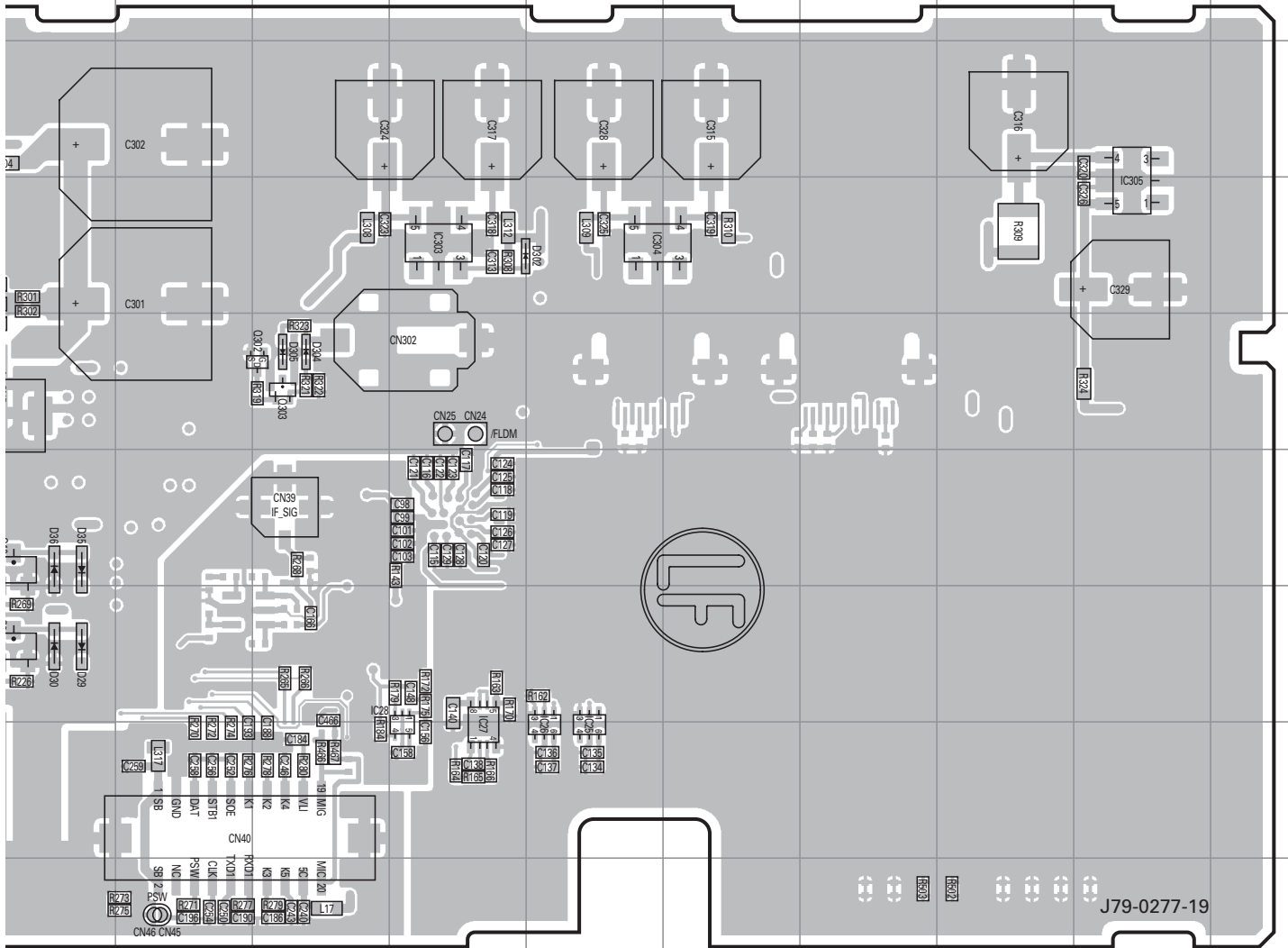

TKR-D810 PC BOARD

CONTROL UNIT (X53-4580-10) Foil side view (J79-0277-19)

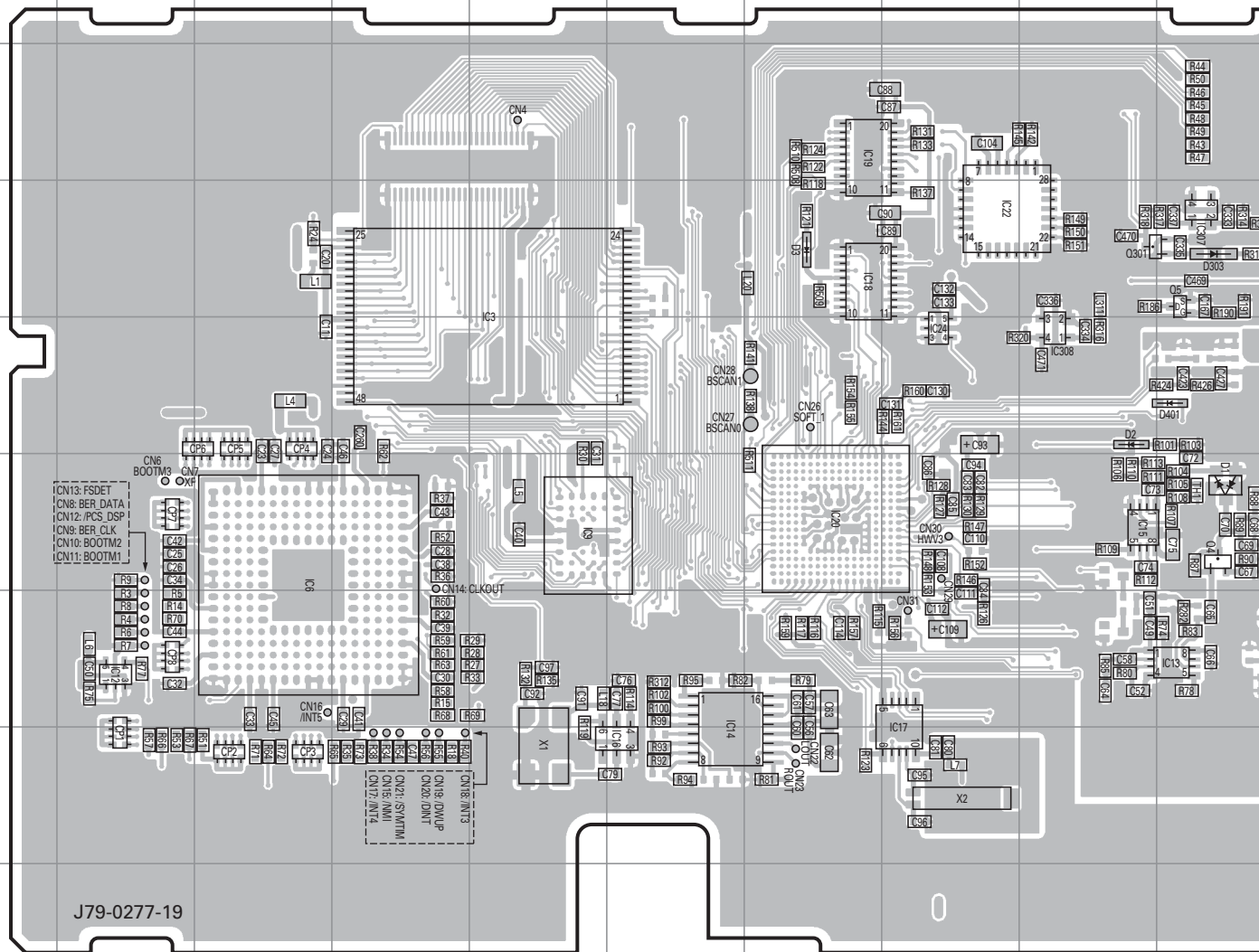

Ref. No.	Address	Ref. No.	Address	Ref. No.	Address	Ref. No.	Address	Ref. No.	Address
IC3	4E	IC13	7J	IC23	5K	IC407	7M	Q405	8Q
IC4	3O	IC14	8F	IC24	5H	IC411	6M	D1	6J
IC5	4O	IC15	6I	IC301	3L	IC412	5O	D2	5I
IC6	6C	IC16	8F	IC307	4J	Q4	6J	D3	4G
IC7	3N	IC17	8H	IC308	5I	Q5	4J	D301	4M
IC8	4N	IC18	4G	IC401	7N	Q301	4I	D303	4J
IC9	6E	IC19	3G	IC402	7N	Q401	7O	D401	5J
IC10	3M	IC20	6G	IC404	7L	Q402	8O		
IC11	4M	IC21	5K	IC405	5Q	Q403	8P		
IC12	7B	IC22	4H	IC406	5M	Q404	8N		

PC BOARD TKR-D810

CONTROL UNIT (X53-4580-10)
Foil side view (J79-0277-19)

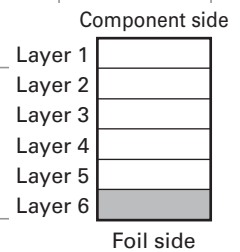
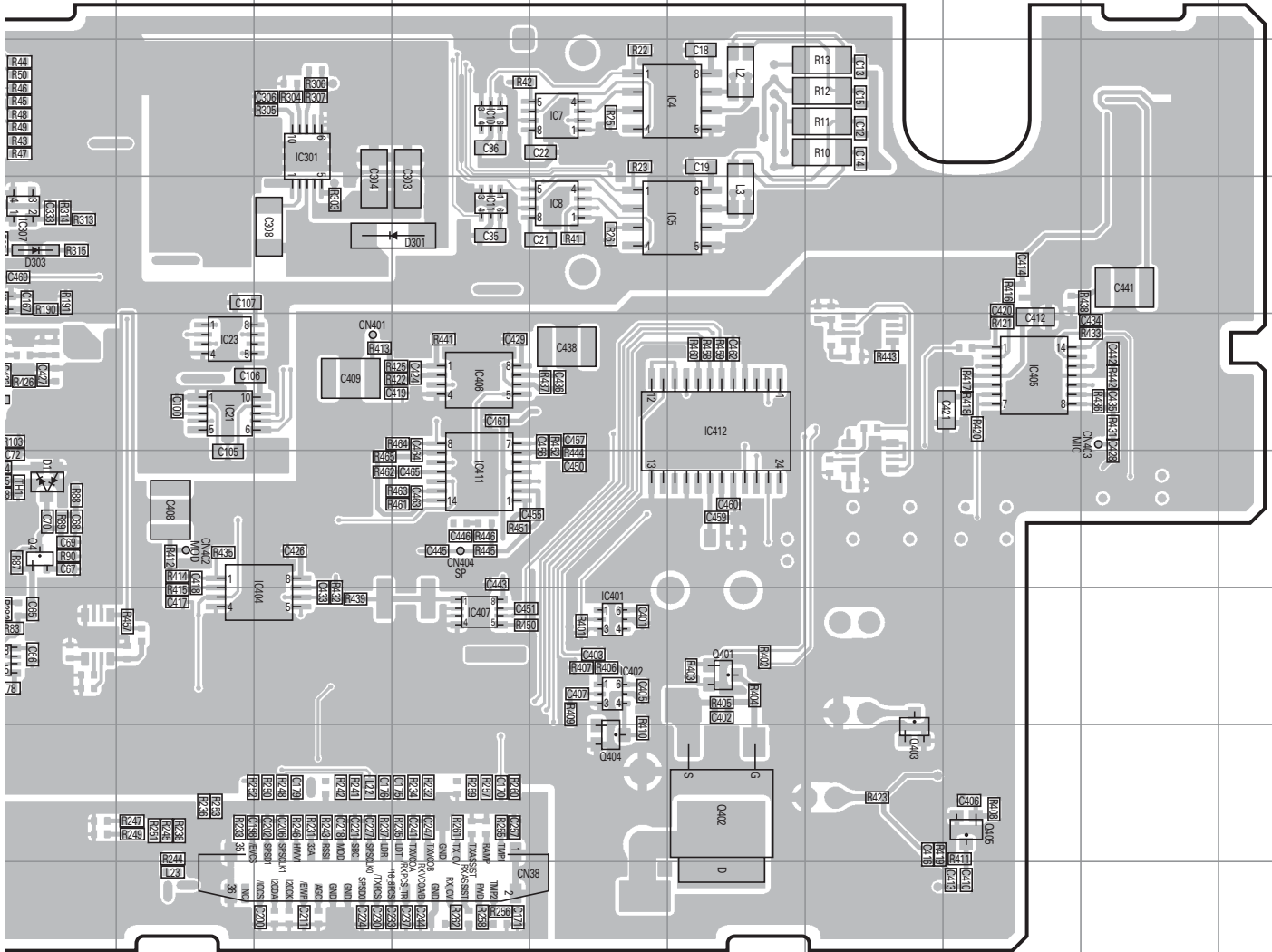

TKR-D810 PC BOARD

DISPLAY UNIT (X54-4060-20) Component side view (J79-0295-09)

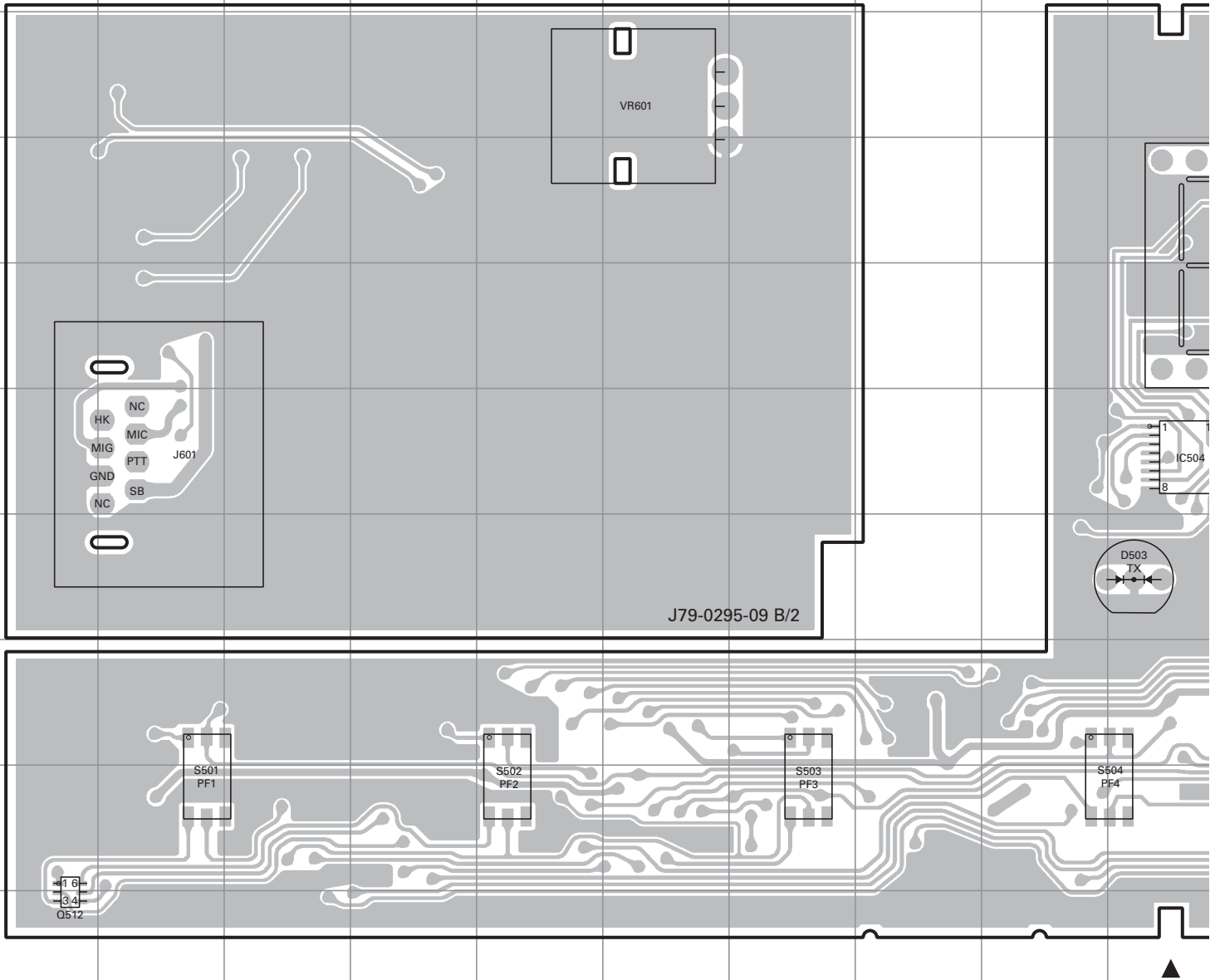

PC BOARD TKR-D810

DISPLAY UNIT (X54-4060-20) Component side view (J79-0295-09)

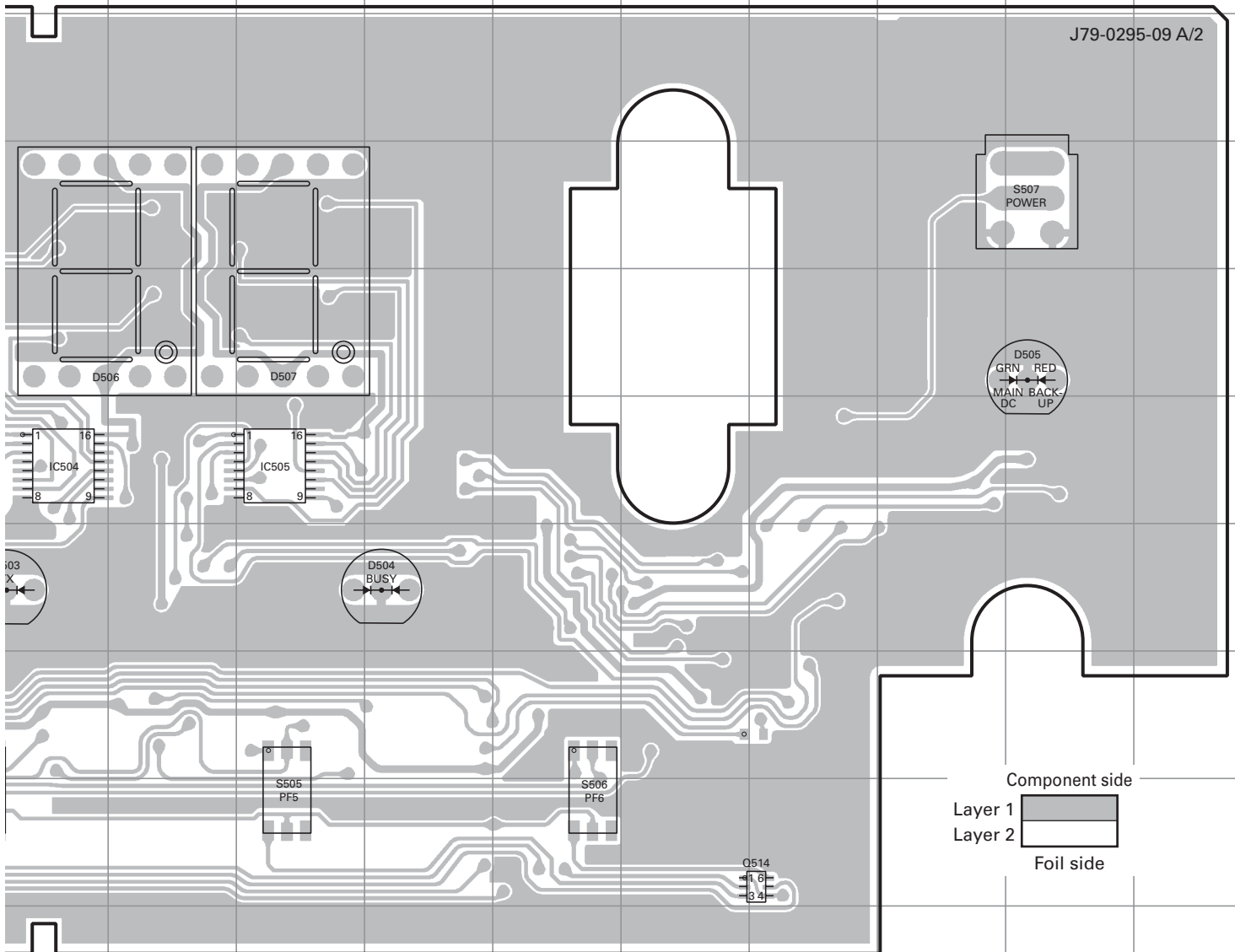

Ref. No.	Address
IC504	6J
IC505	6L
Q512	10A
Q514	9P
D503	7J
D504	7M
D505	5R
D506	5J
D507	5L

TKR-D810 PC BOARD

DISPLAY UNIT (X54-4060-20) Foil side view (J79-0295-09)

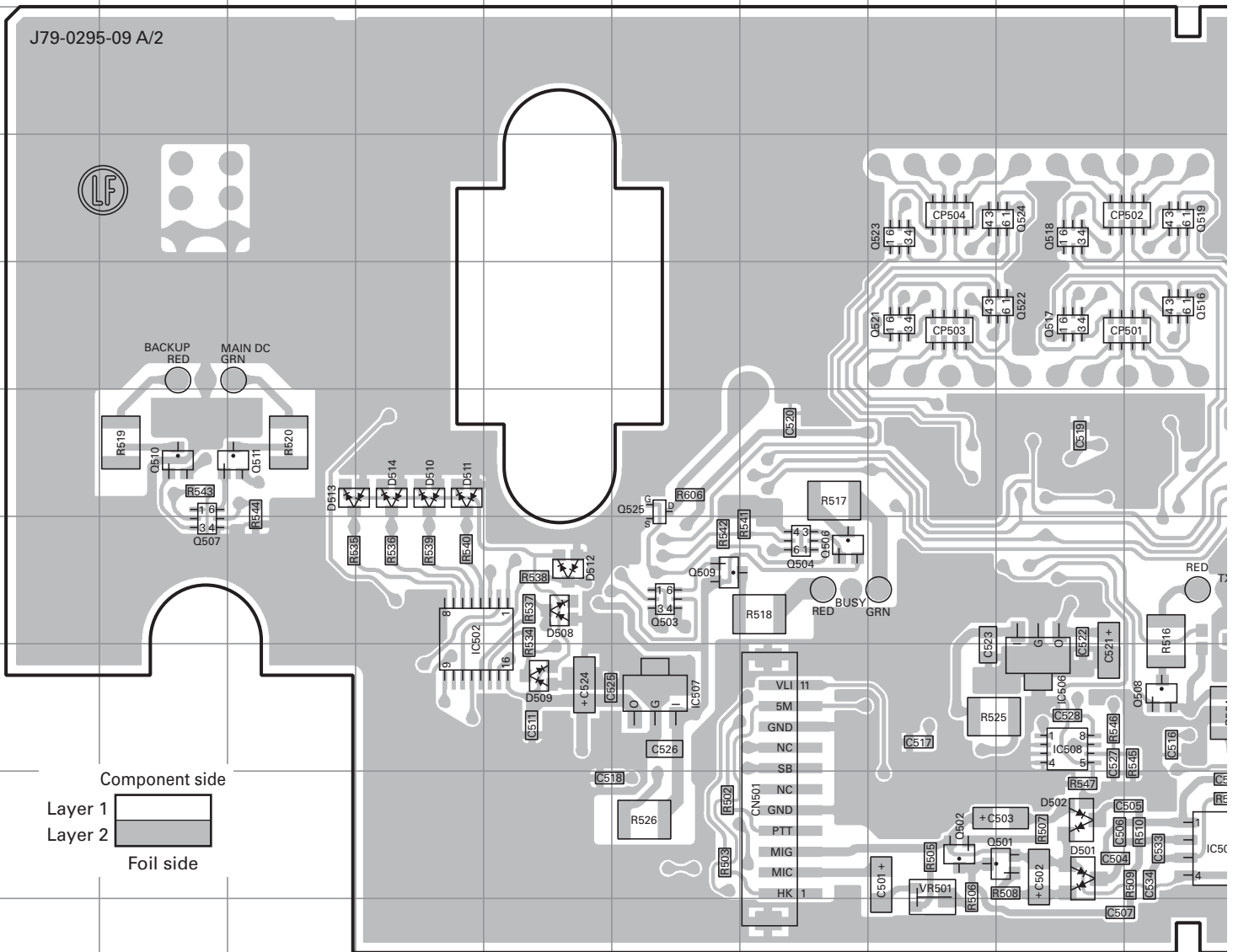

Ref. No.	Address	Ref. No.	Address	Ref. No.	Address	Ref. No.	Address
IC501	9J	Q506	7G	Q519	4J	D510	6D
IC502	7D	Q507	7B	Q521	5H	D511	6D
IC503	9P	Q508	8J	Q522	5I	D512	7E
IC506	8I	Q509	7F	Q523	4H	D513	6C
IC507	8F	Q510	6B	Q524	4I	D514	6D
IC508	8I	Q511	6C	Q525	6F	D601	5R
Q501	9I	Q513	9N	D501	9I	D602	4R
Q502	9H	Q516	5J	D502	9I	D603	4R
Q503	7F	Q517	5I	D508	7E		
Q504	7G	Q518	4I	D509	8E		

PC BOARD TKR-D810

DISPLAY UNIT (X54-4060-20) Foil side view (J79-0295-09)

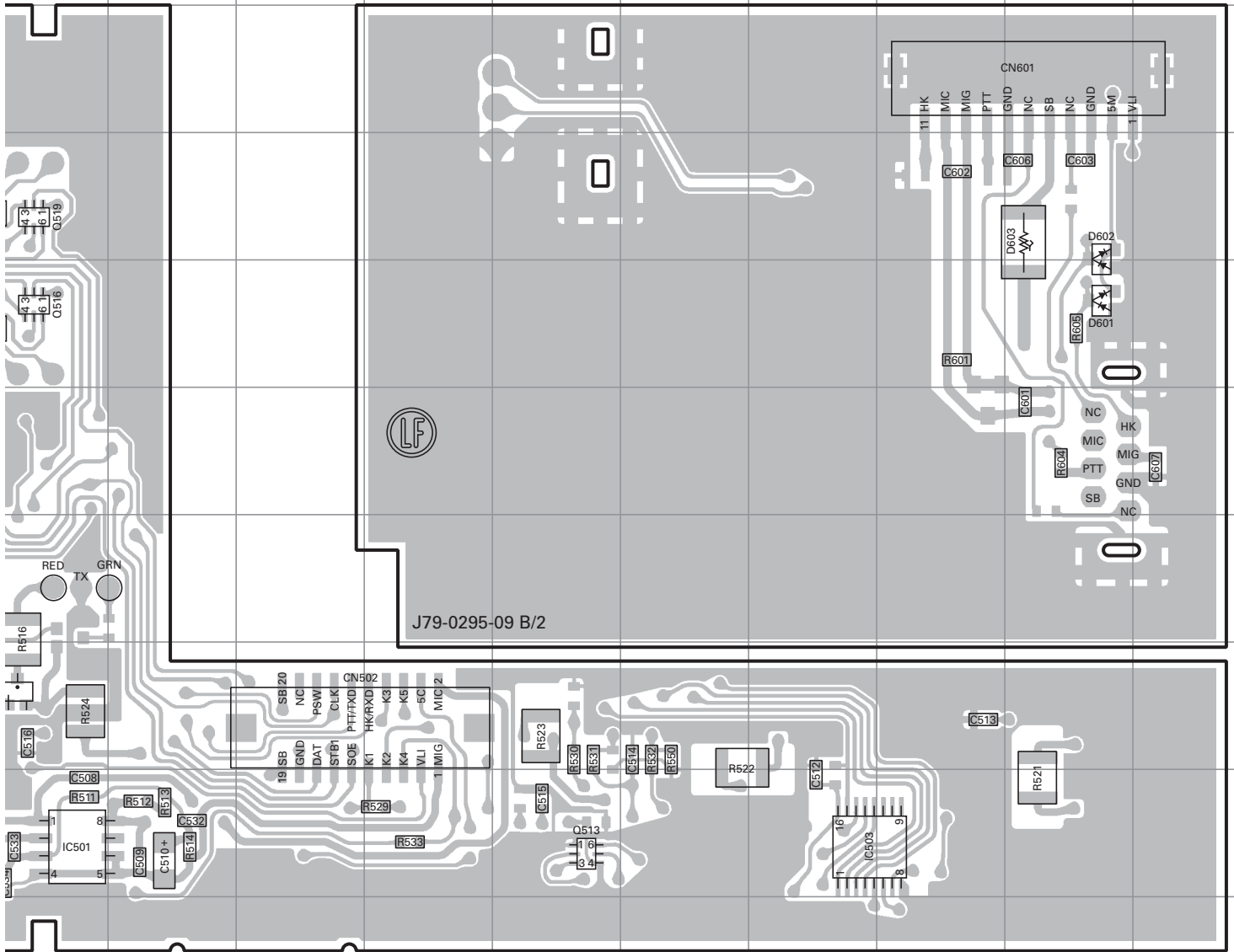

TKR-D810 PC BOARD

TX-RX UNIT (X57-897K-03(TKR-D810(K2),X57-897K-02(TKR-D810(K))
Component side view (J7C-0066-00)

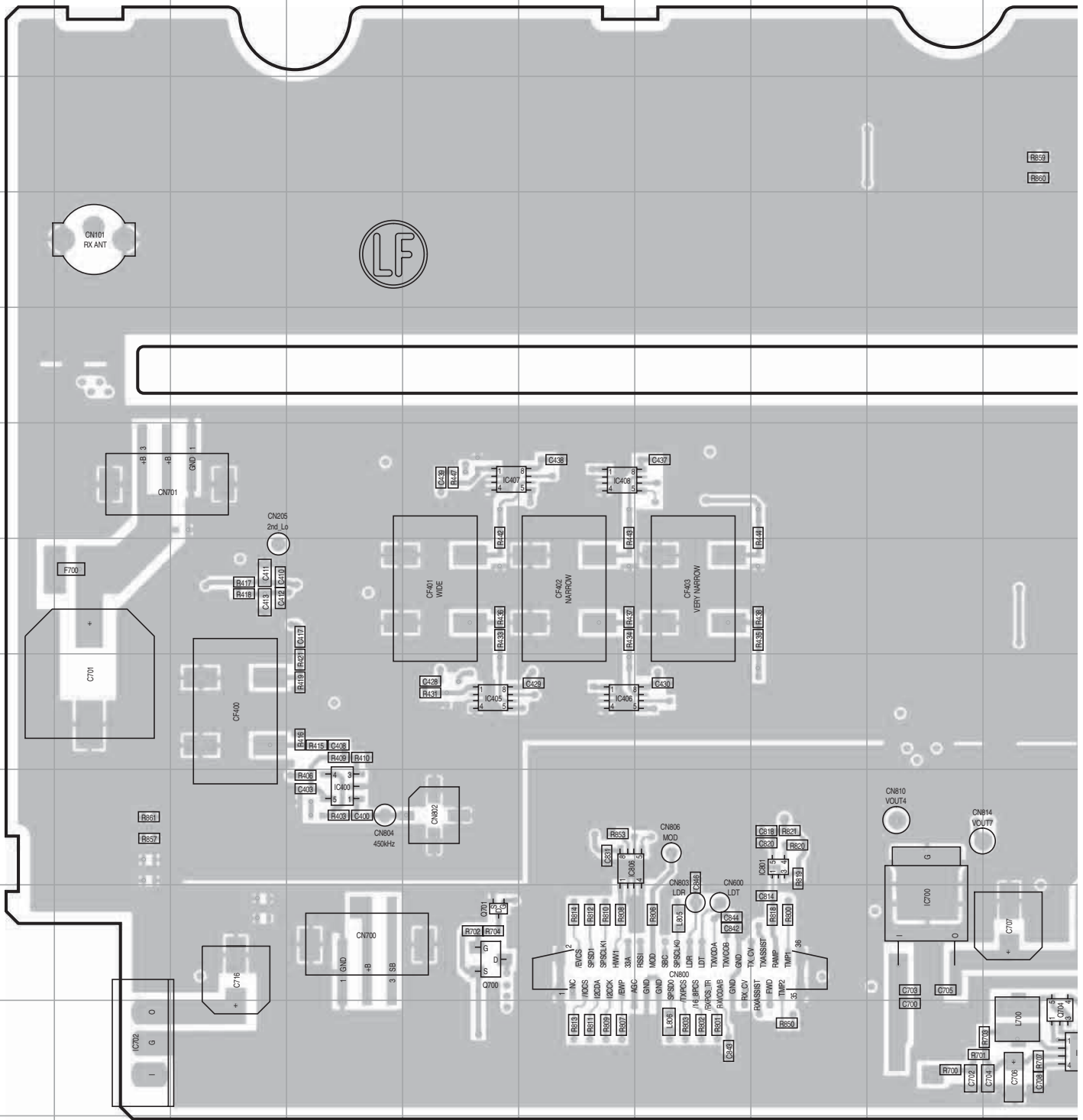

Ref. No.	Address	Ref. No.	Address	Ref. No.	Address	Ref. No.	Address
IC203	9M	IC603	6O	IC701	11J	Q701	10E
IC400	9D	IC604	6P	IC702	11B	Q704	11J
IC405	8E	IC605	6M	IC703	10K	Q705	10K
IC406	8F	IC606	5M	IC801	9H	Q706	9K
IC407	6E	IC608	5M	IC806	9F		
IC408	6F	IC700	10I	Q700	10E		

PC BOARD TKR-D810

TX-RX UNIT (X57-897K-03(TKR-D810(K)), X57-897K-02(TKR-D810(K))
Component side view (J7C-0066-00)

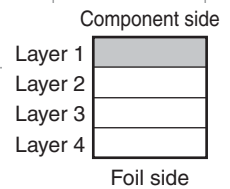
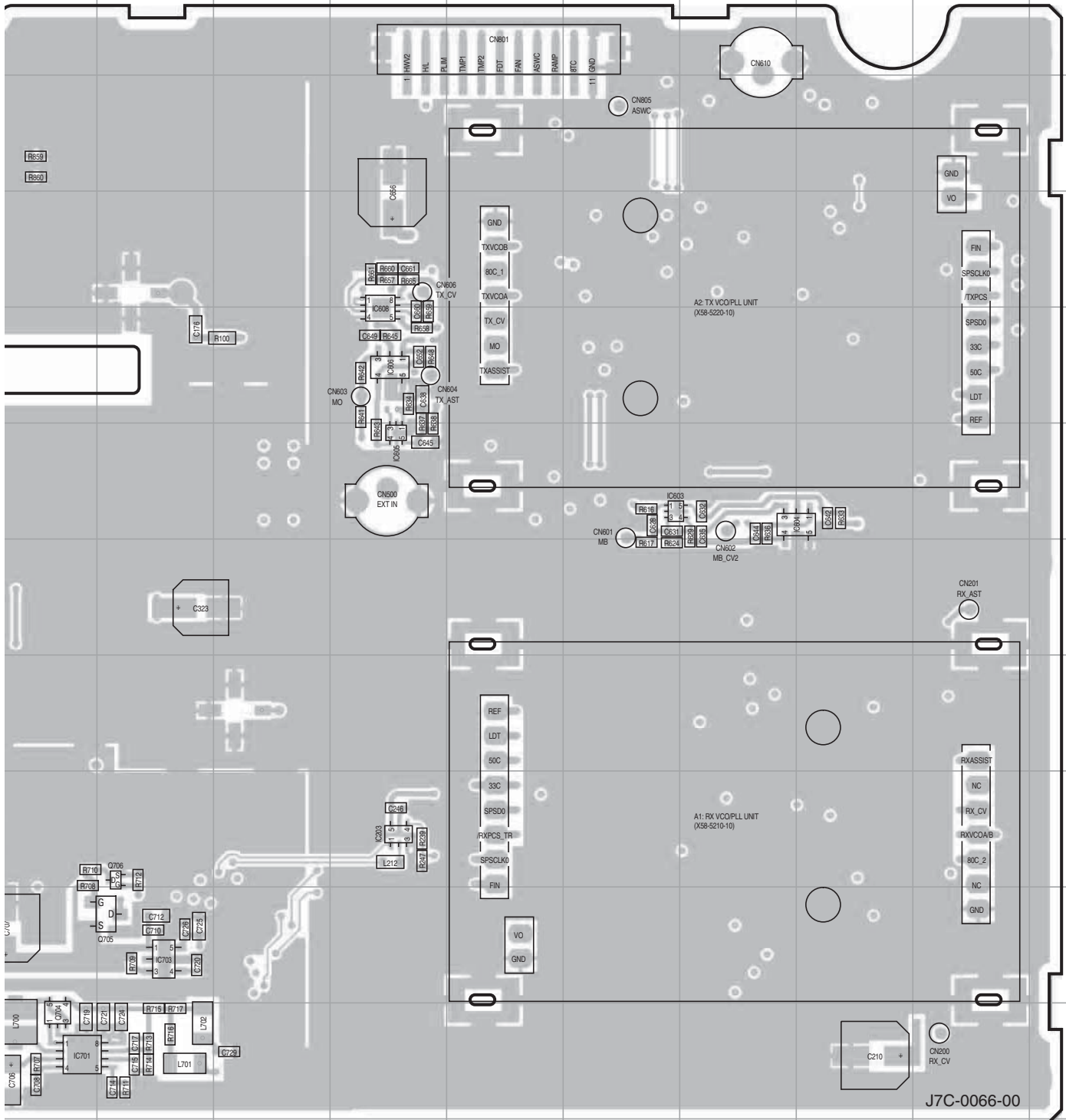

TKR-D810 PC BOARD

TX-RX UNIT (X57-897K-03(TKR-D810(K2),X57-897K-02(TKR-D810(K))
 Foil side view (J7C-0066-00)

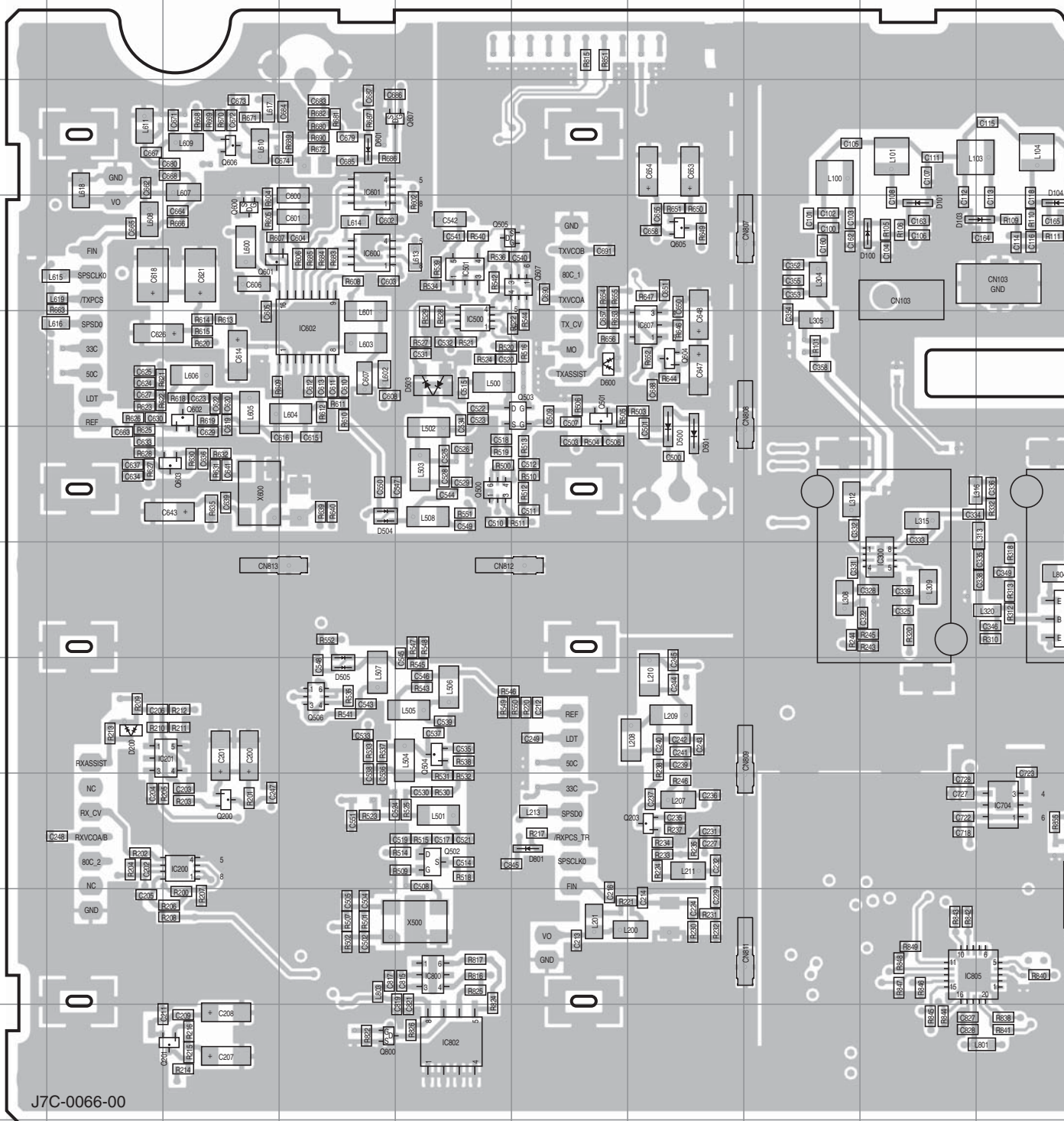

Ref. No.	Address	Ref. No.	Address	Ref. No.	Address	Ref. No.	Address	Ref. No.	Address	Ref. No.	Address	Ref. No.	Address	Ref. No.	Address
IC100	4P	IC402	8P	IC600	4D	IC802	11E	Q200	9C	Q500	6E	Q506	8D	Q604	
IC101	4O	IC403	7P	IC601	3D	IC803	10L	Q201	11C	Q501	5F	Q507	4F	Q605	
IC200	9C	IC404	8O	IC602	5D	IC804	10K	Q202	6P	Q502	9E	Q600	4C	Q606	
IC201	8C	IC409	7Q	IC607	5G	IC805	10I	Q203	9G	Q503	5F	Q601	4C	Q607	
IC300	7I	IC500	5E	IC704	9J	Q100	4Q	Q300	7O	Q504	8E	Q602	5C	Q702	
IC401	7Q	IC501	4E	IC800	10E	Q101	3K	Q301	7J	Q505	4E	Q603	6C	Q703	

TKR-D810 PC BOARD

RX VCO/PLL UNIT (X58-5210-10(TKR-D810(K2)),X58-5210-11(TKR-D810(K))
 Component side view (J79-0269-09) Foil side view (J79-0269-09)

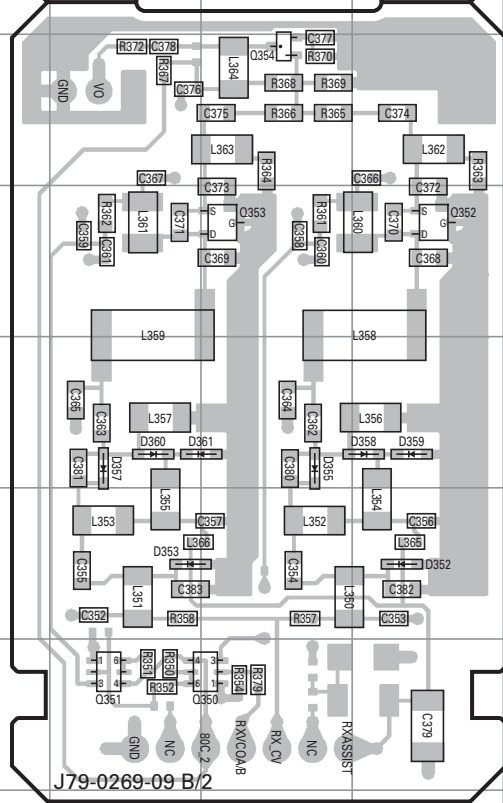
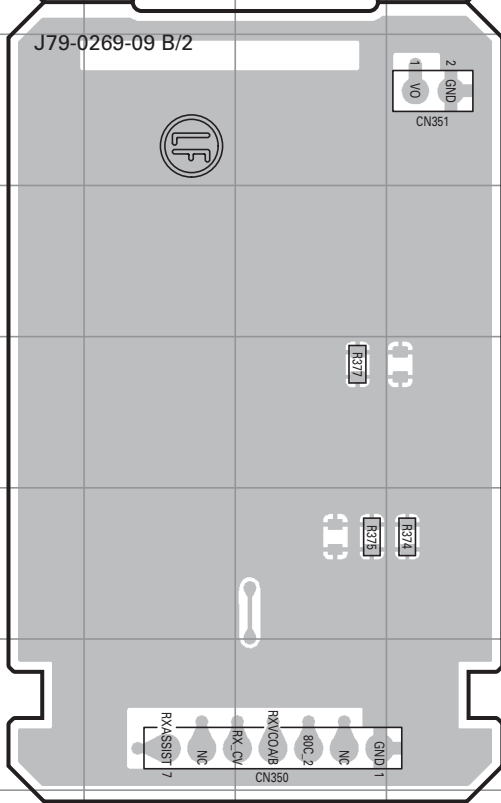
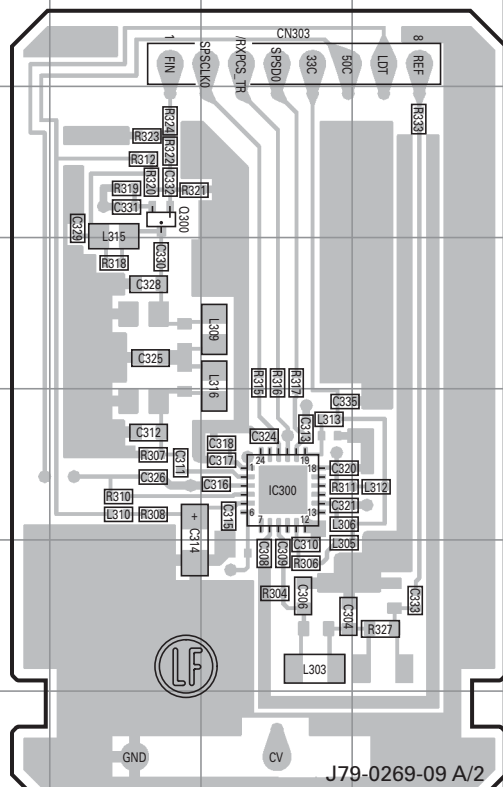
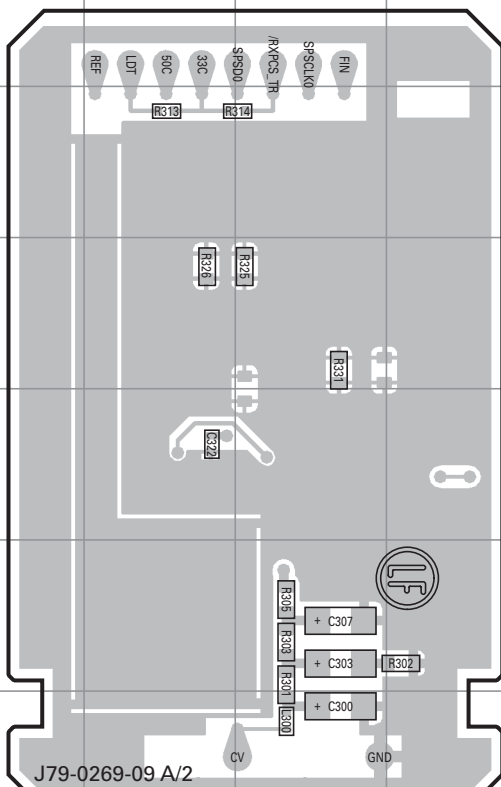

Ref. No.	Address
IC300	5G
Q300	3F
Q350	12G
Q351	12F
Q352	9H
Q353	9G
Q354	8G
D352	11H
D353	11F
D355	10G
D357	10F
D358	10H
D359	10H
D360	10F
D361	10G

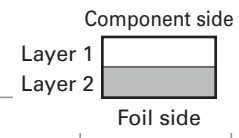
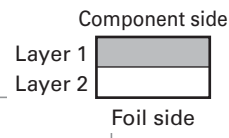

PC BOARD TKR-D810

TX VCO/PLL UNIT (X58-5220-10(TKR-D810(K2)),X58-5220-11(TKR-D810(K))
 Component side view (J79-0270-09) Foil side view (J79-0270-09)

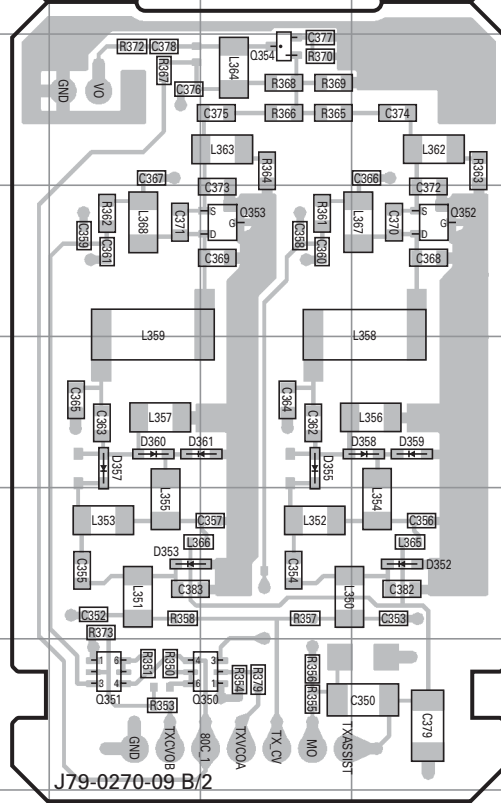
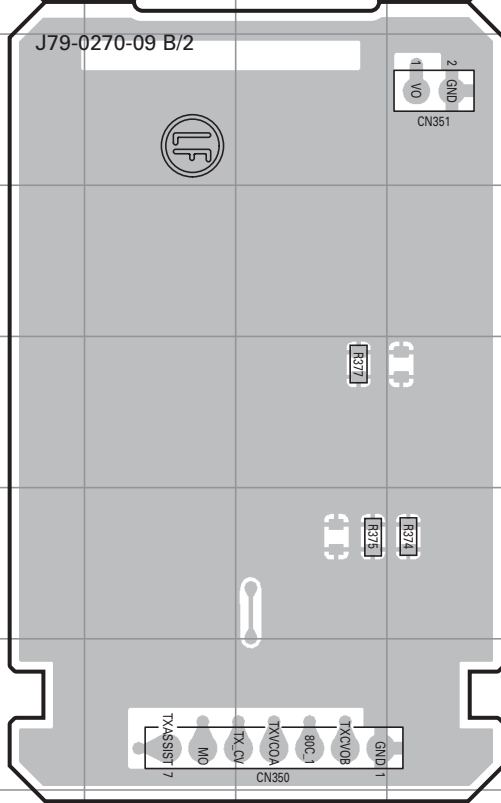
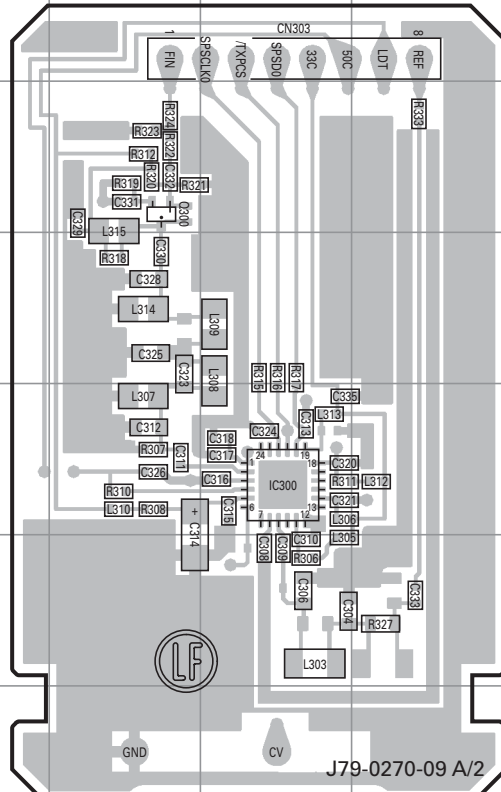
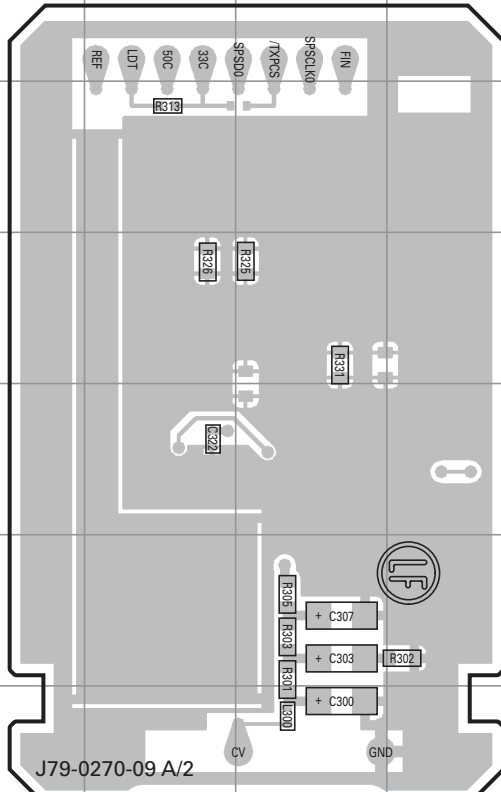

Ref. No.	Address
IC300	5G
Q300	3F
Q350	12G
Q351	12F
Q352	9H
Q353	9G
Q354	8G
D352	11H
D353	11F
D355	10G
D357	10F
D358	10H
D359	10H
D360	10F
D361	10G

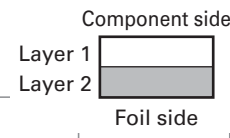
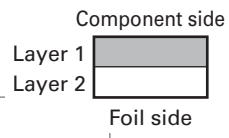

TKR-D810 INTERCONNECTION DIAGRAM

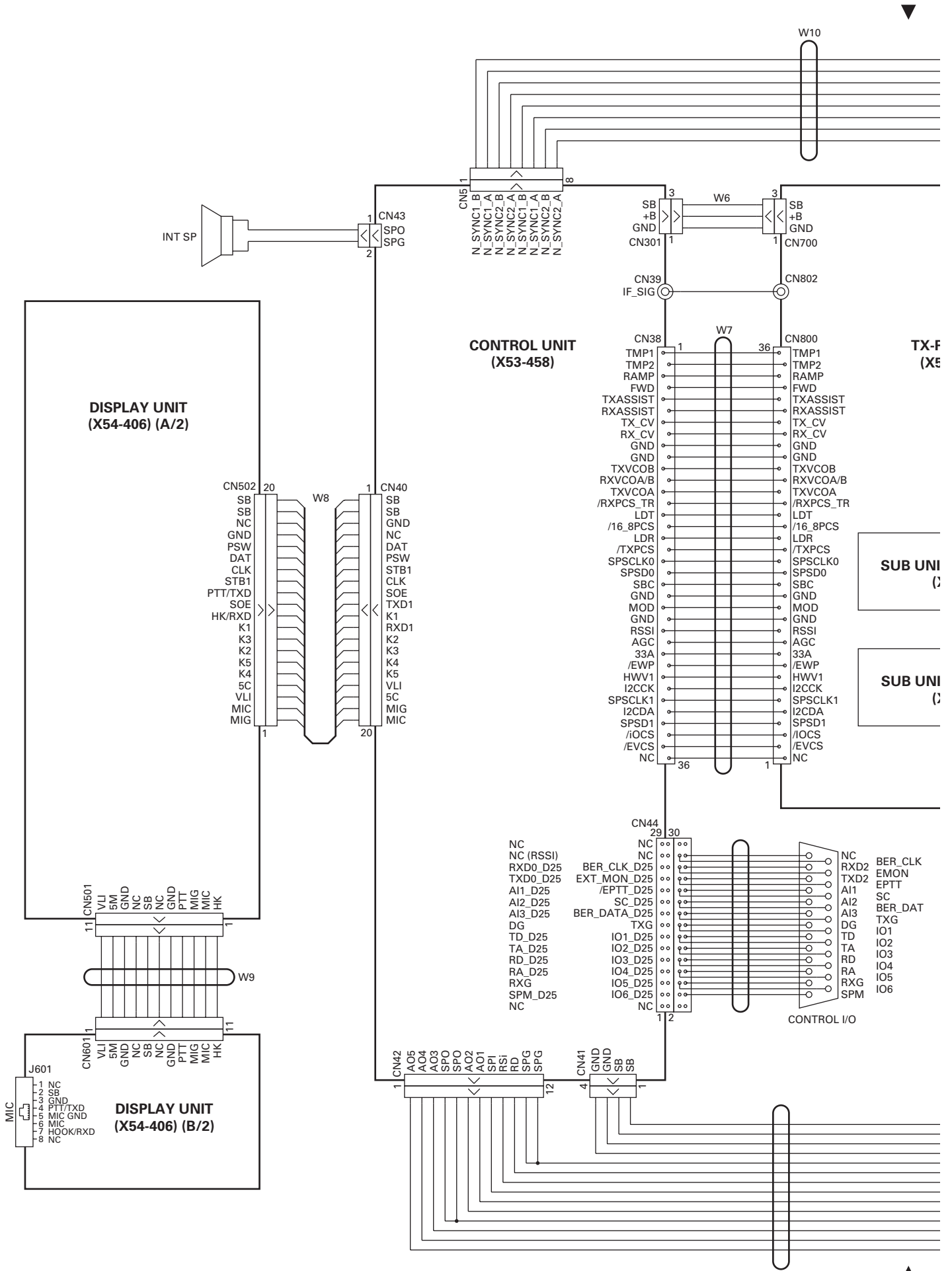

INTERCONNECTION DIAGRAM TKR-D810

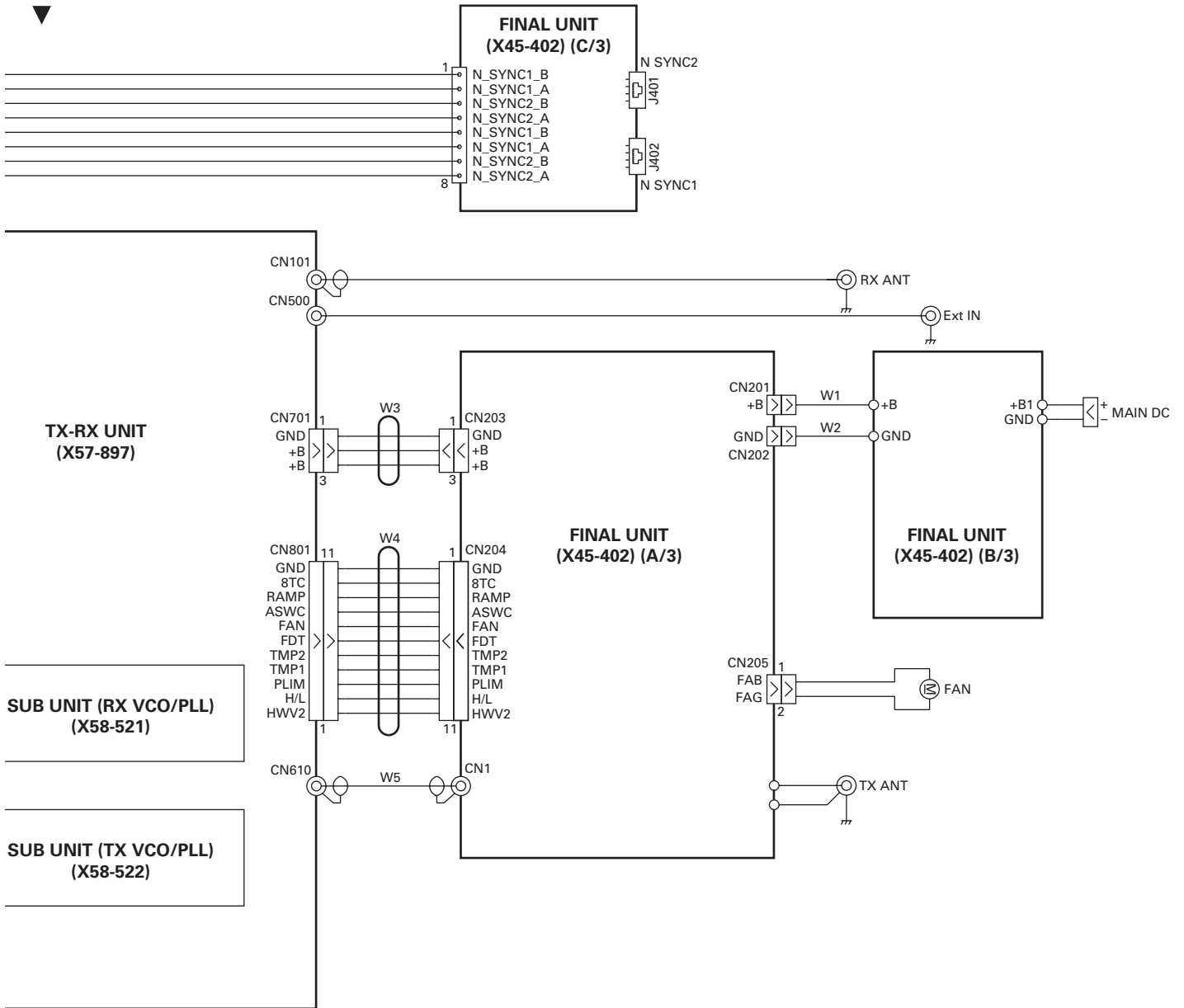

- 3ER_CLK
- EMON
- EPTT
- 3C
- 3ER_DAT
- IXG
- O1
- O2
- O3
- O4
- O5
- O6

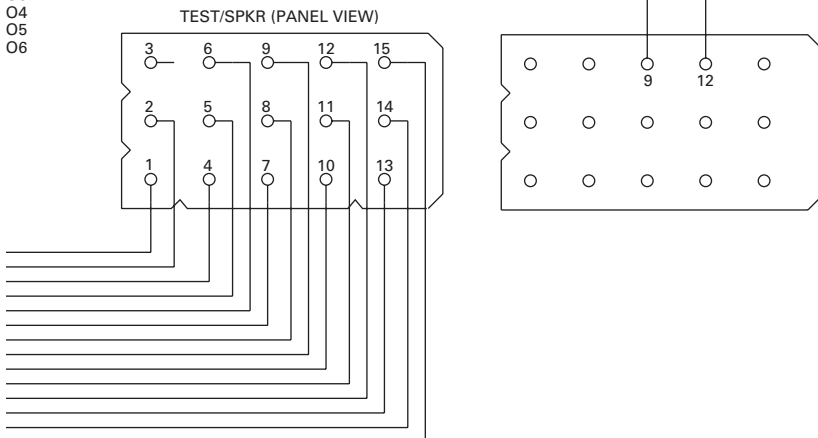

TKR-D810 SCHEMATIC DIAGRAM

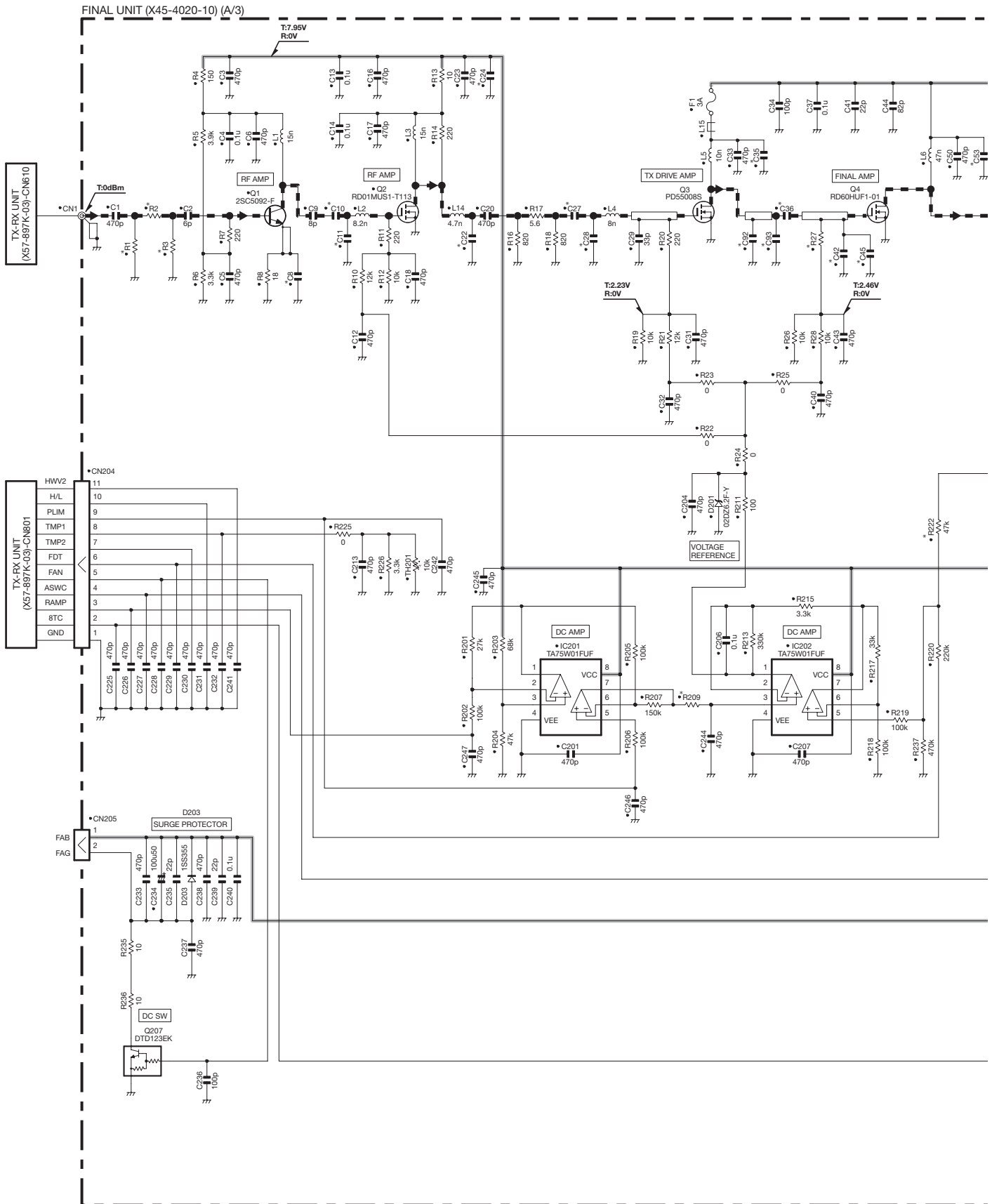

SCHEMATIC DIAGRAM TKR-D810

FINAL UNIT (X45-4020-10) (A/3)

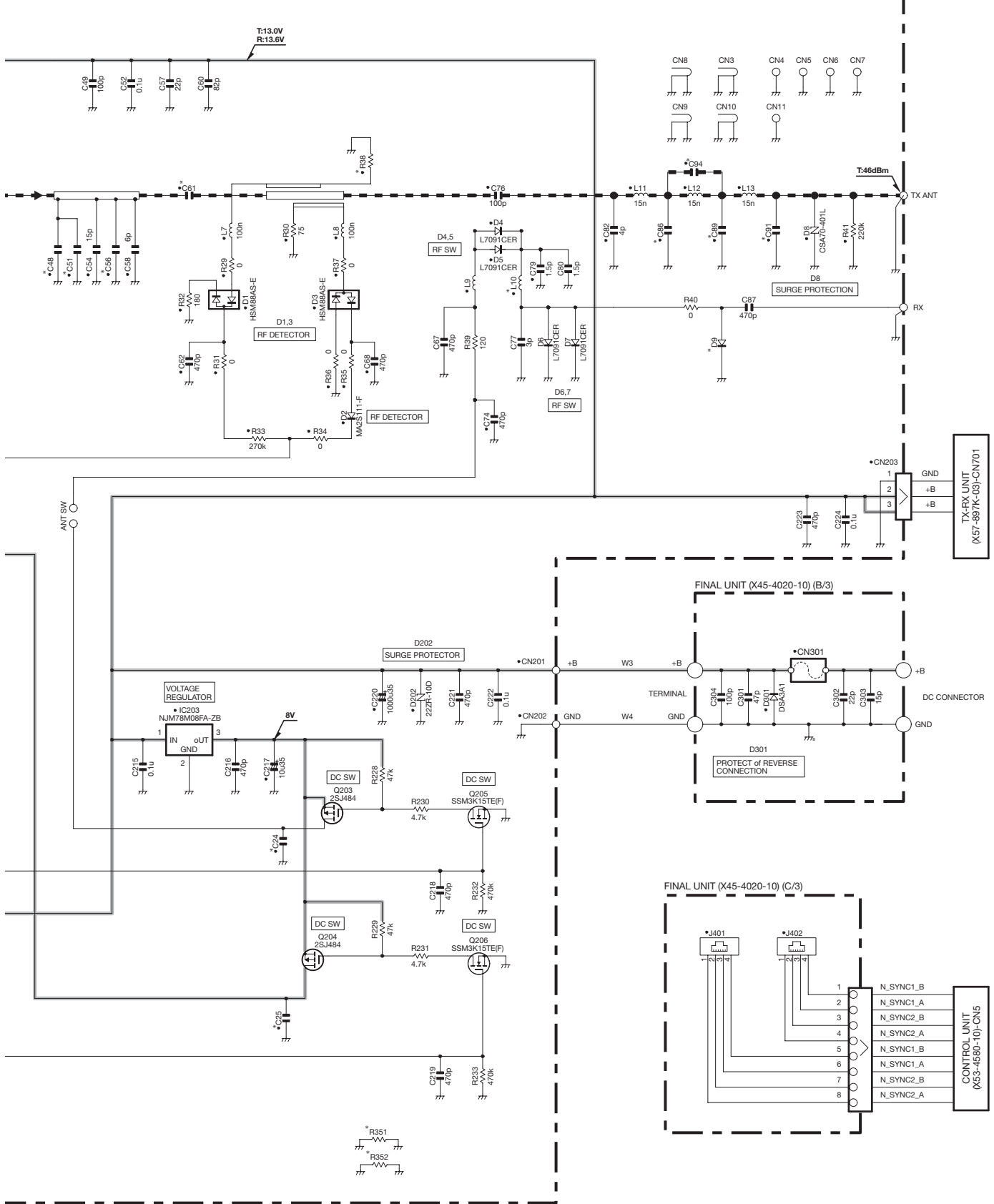

Note : The components marked with a dot (•) are parts of layer 1.

TKR-D810 SCHEMATIC DIAGRAM

DISPLAY UNIT (X54-4060-20) (A/2)

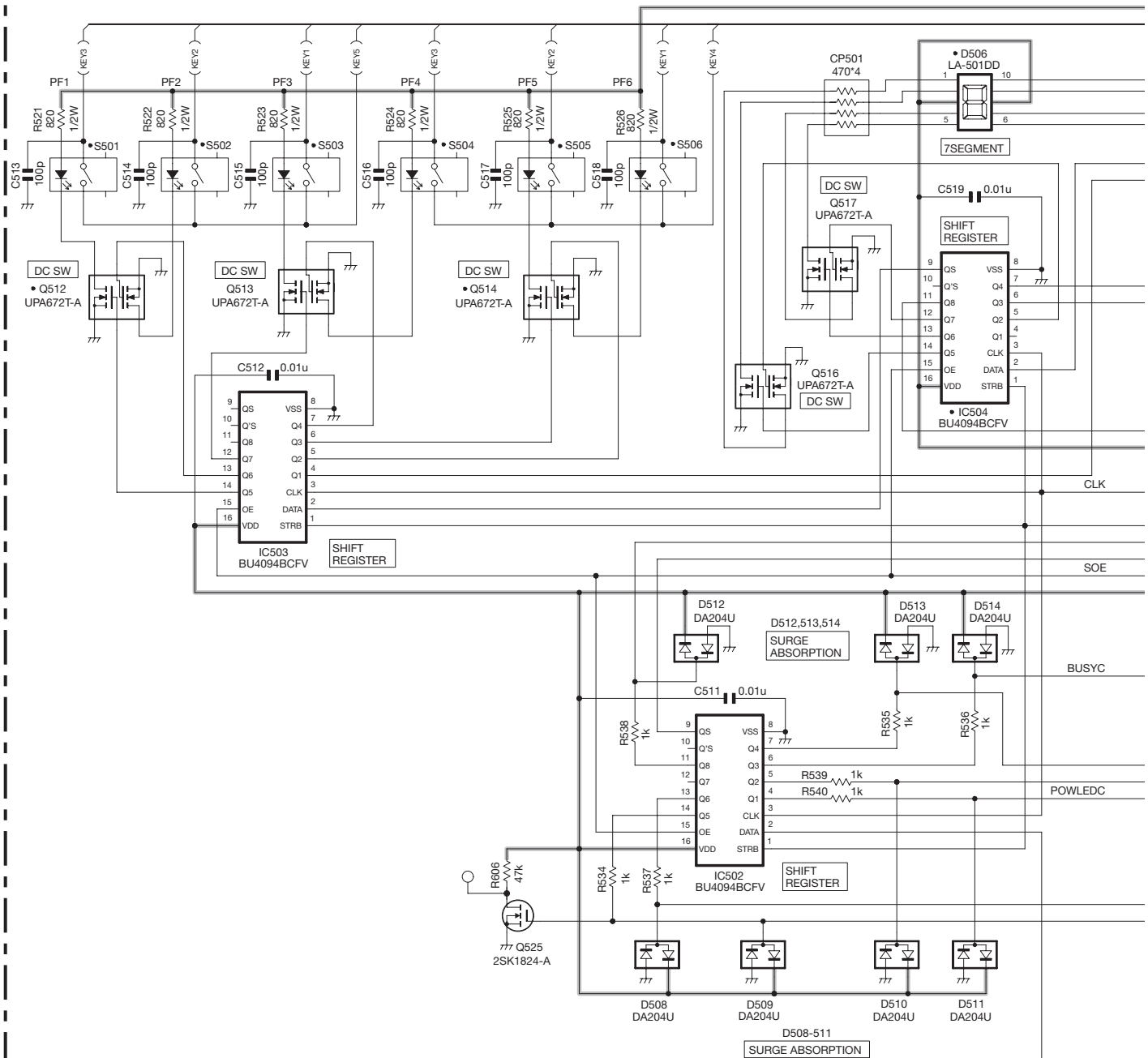

DISPLAY UNIT (X54-4060-20) (B/2)

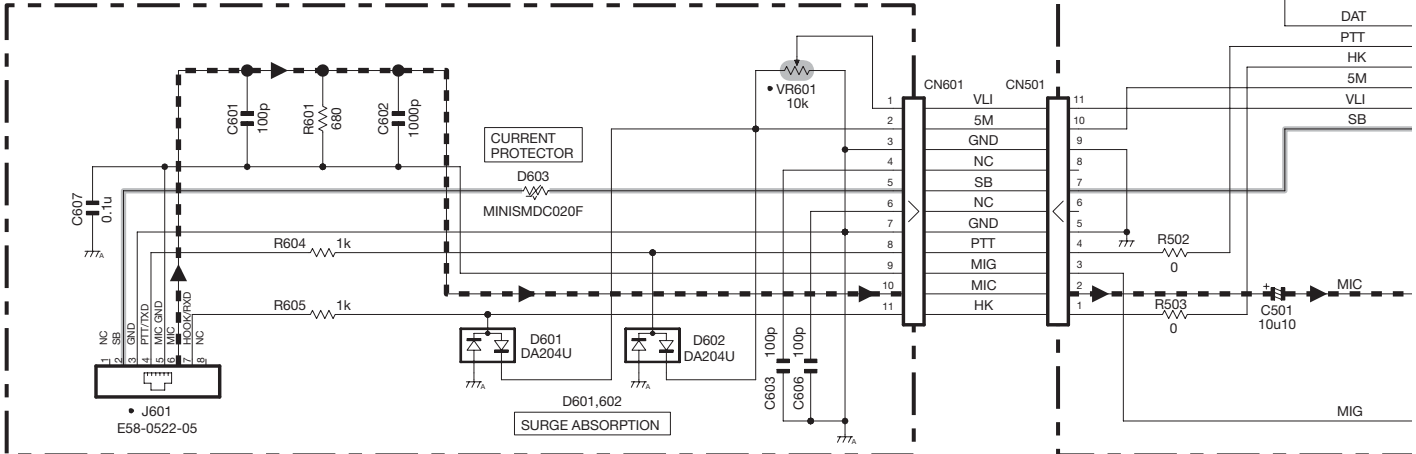

SCHEMATIC DIAGRAM TKR-D810

DISPLAY UNIT (X54-4060-20) (A/2)

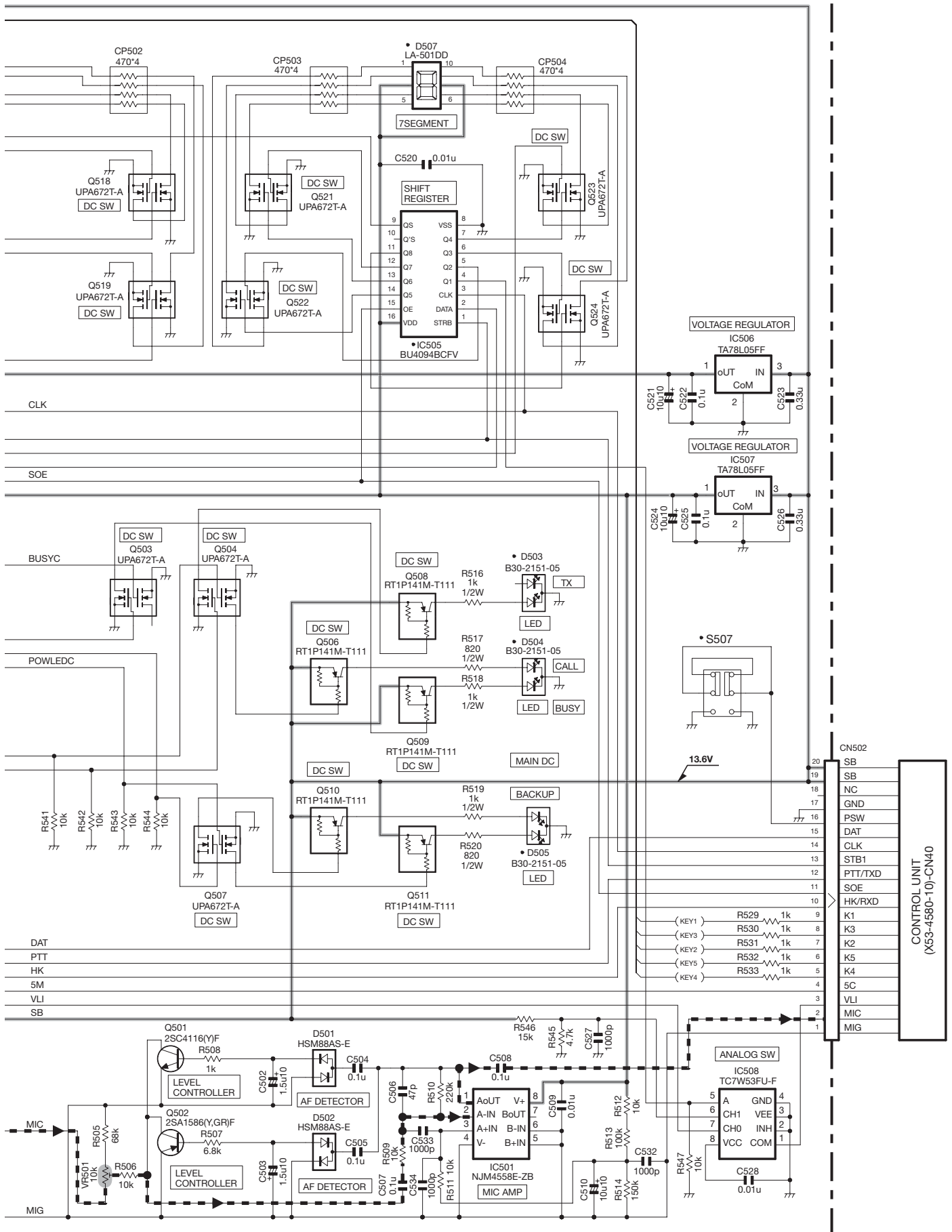

Note : The components marked with a dot (•) are parts of layer 1.

TKR-D810 SCHEMATIC DIAGRAM

TX-RX UNIT (X57-897K-03)

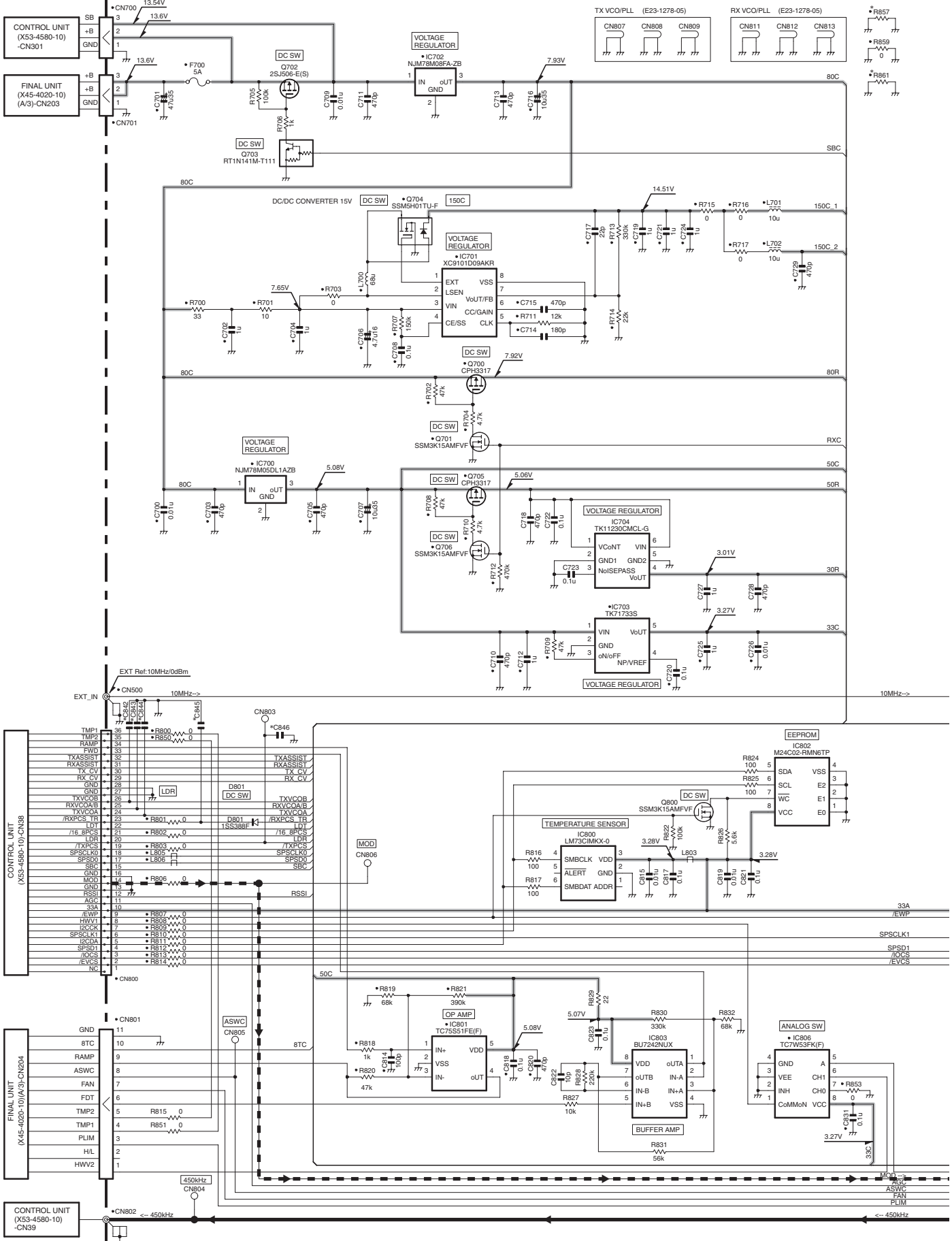

SCHEMATIC DIAGRAM TKR-D810

TX-RX UNIT (X57-897K-03)

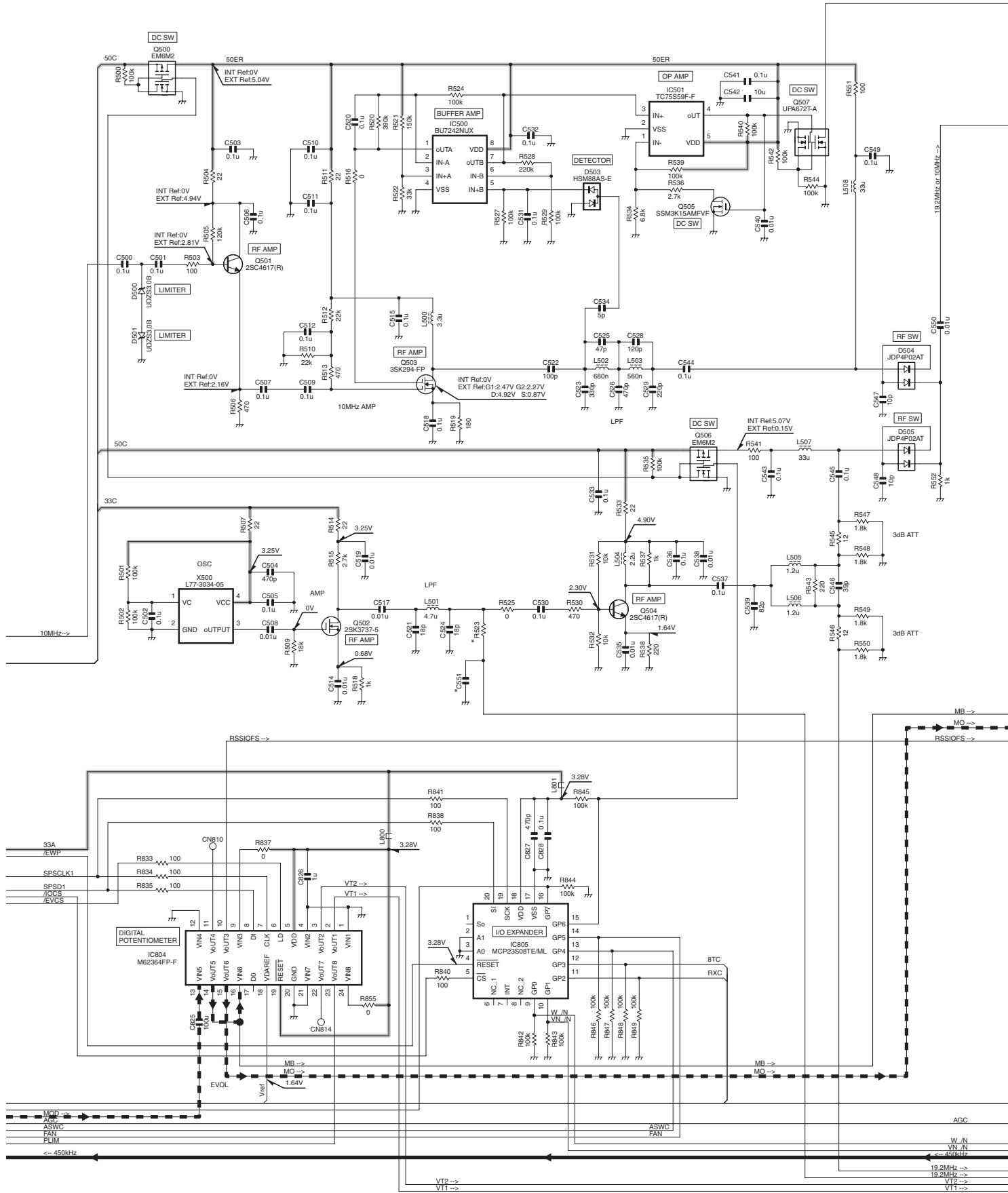

TKR-D810 SCHEMATIC DIAGRAM

TX-RX UNIT (X57-897K-03)

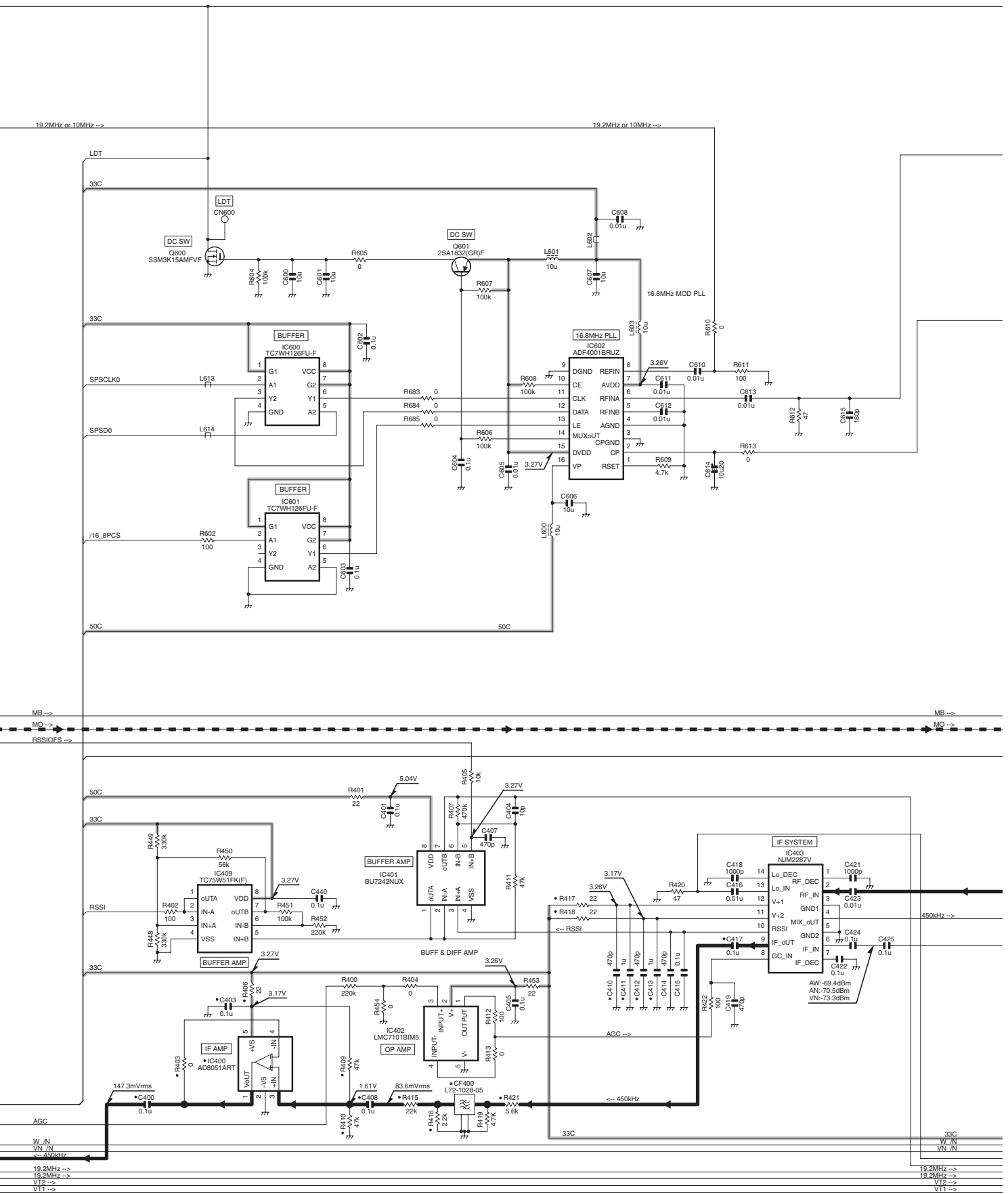

SCHEMATIC DIAGRAM TKR-D810

TX-RX UNIT (X57-897K-03)

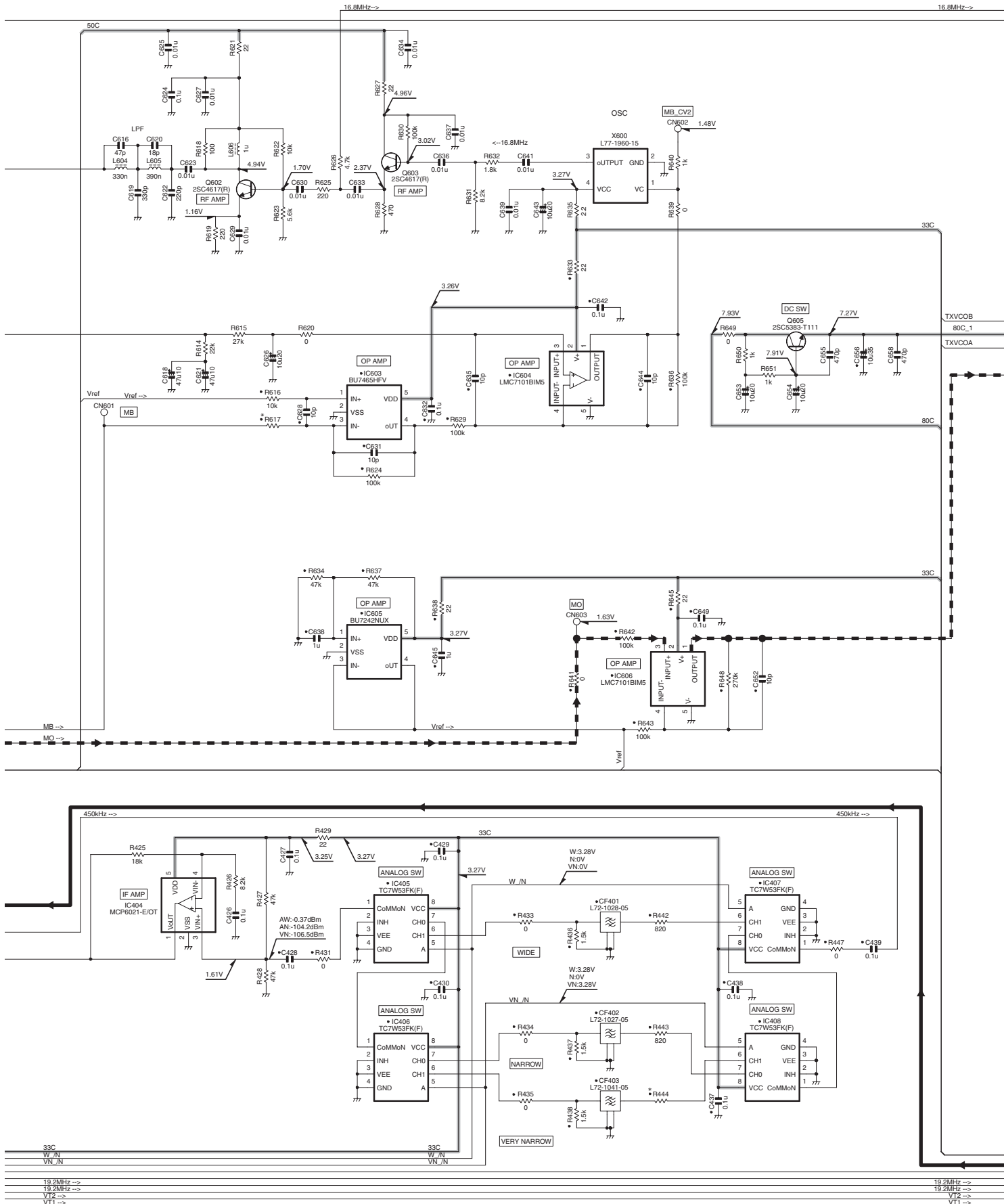

TKR-D810 SCHEMATIC DIAGRAM

TX-RX UNIT (X57-897K-03)

SUB UNIT (TX VCO/PLL) (X58-522X-XX) (B/2)

	C352	C353	C354	C355	C363	C364	C365	C368	C369	C370	C371	C372	C373	C382	C383	D352	D353	D355	D357
0-10	-	-	470p	470p	12p	0.5p(B)	1p(B)	6p(B)	5p(B)	5p(B)	5p(B)	5p(B)	3p(B)	5p(B)	5p(B)	1SV278F	1SV278F	1SV282-F	1SV282-F
0-11	100p	100p	47p	27p	9p(B)	2p(B)	1.5p(B)	4p(B)	5p(B)	7p(B)	4p(B)	6p(B)	3p(B)	5p(B)	5p(B)	1SV325F	1SV325F	1SV278F	1SV278F

	L350	L351	L358	L359	L360	L361	L367	L368	Q354	R356	R374	R375
0-10	1u	1u	22n	17.5n	10u	10u	-	-	2SC5636	22	0	-
0-11	10u	10u	17.5n	17.5n	-	-	1u	1u	2SC5108(F)	27	-	0

SUB UNIT (TX VCO/PLL) (X58-522X-XX) (B/2)

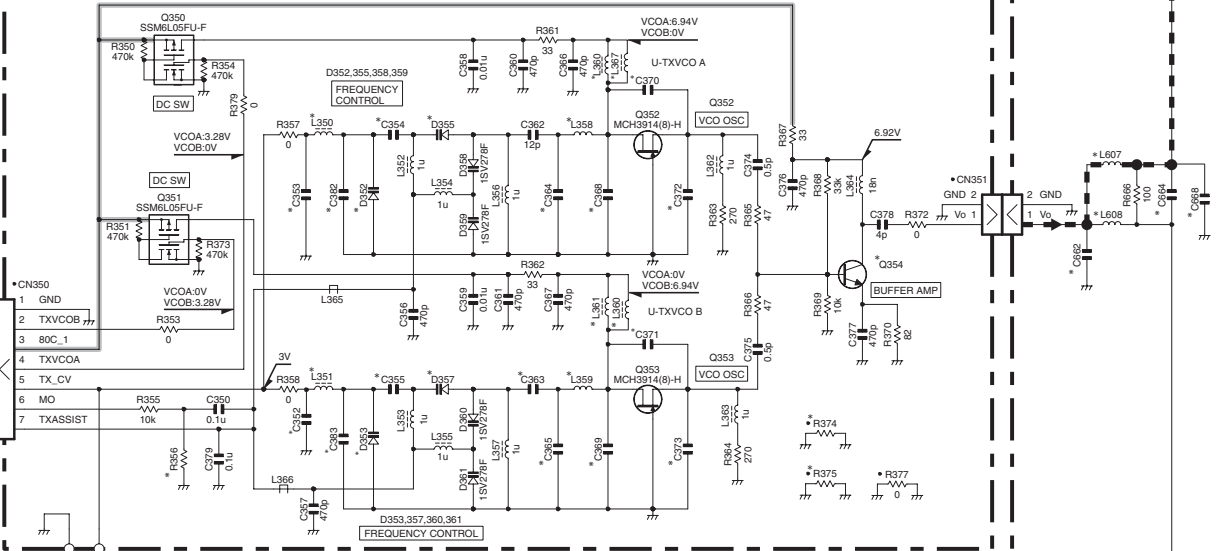

SUB UNIT (TX VCO/PLL) (X58-522X-XX) (A/2)

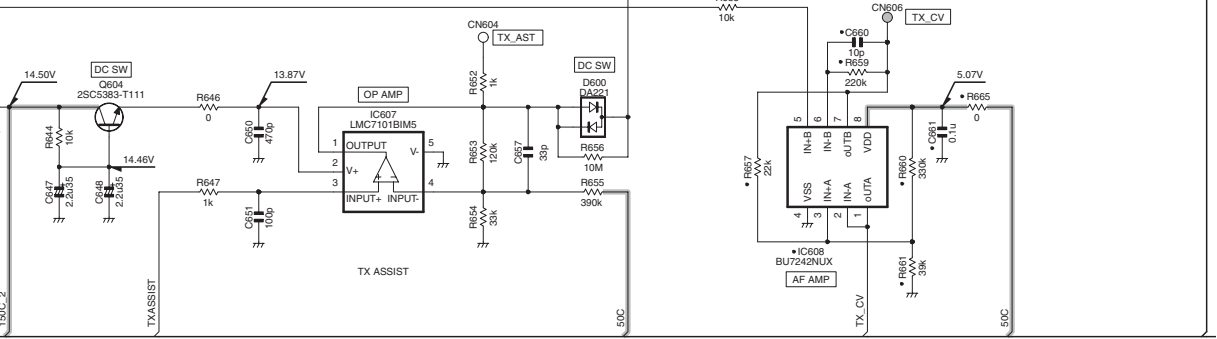
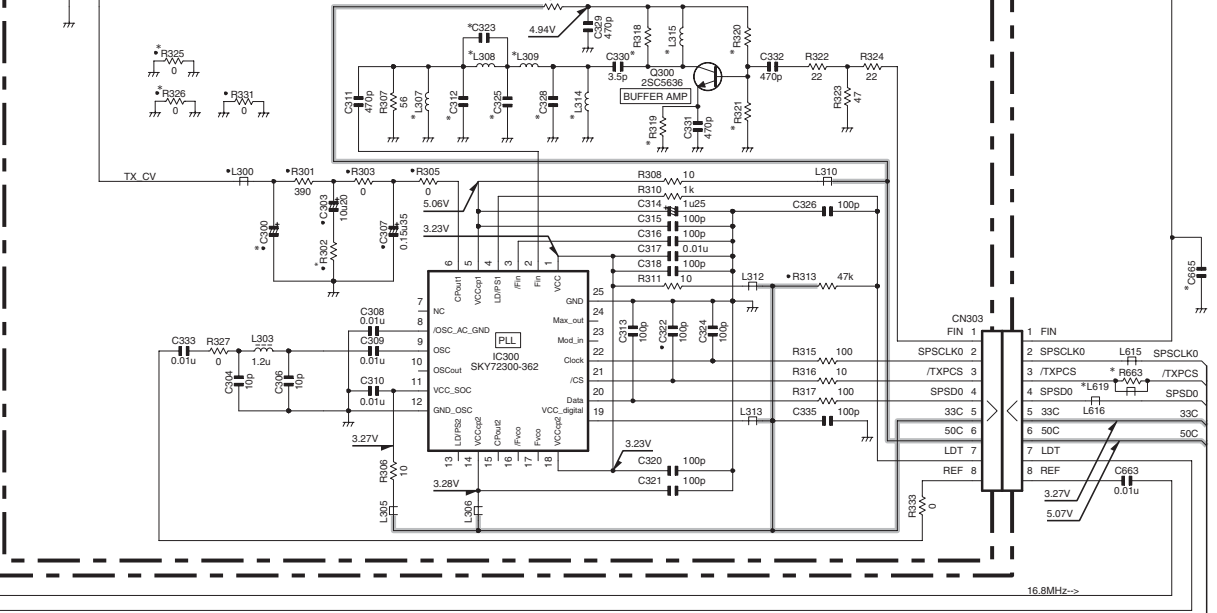

19.2MHz -> 19.2MHz -> 19.2MHz -> 19.2MHz -> 19.2MHz -> 19.2MHz ->

SCHEMATIC DIAGRAM TKR-D810

TX-RX UNIT (X57-897K-03)

SUB UNIT (TX VCO/PLL) (X58-522X-XX) (A/2)

0-10	C300	C312	C323	C325	C328	C330	C332	L307	L308	L309	L314	L315	R302	R312	R318	R319	R320	R321	R325	R326	
	0.047u	16	12p(G)	3p(B)	-	12p(G)	470p	10n	-	47n	10n	39n	150	47	2.2k	390	10k	5.6k	0	-	0
0-11	0.15u	35	5p(B)	-	5p(B)	4p	10p	-	15n	15n	-	22n	120	33	120	150	22k	10k	-	-	0

SUB UNIT (RX VCO/PLL) (X58-521X-XX) (B/2)

0-12	C323	C325	C328	L308	L309	R325	R326
	10p	10p	10p	10n	10n	25C2698	0
0-13	5p(B)	5p(B)	5p(B)	22n	22n	25C2698	0
0-14	10p	10p	10p	18n	18n	25C2698	0

SUB UNIT (RX VCO/PLL) (X58-521X-XX) (A/2)

0-15	7p(B)	12p	7p(B)	22n	22n	100	0	-	0
0-16	5p(B)	10p	5p(B)	18n	18n	-	-	-	0

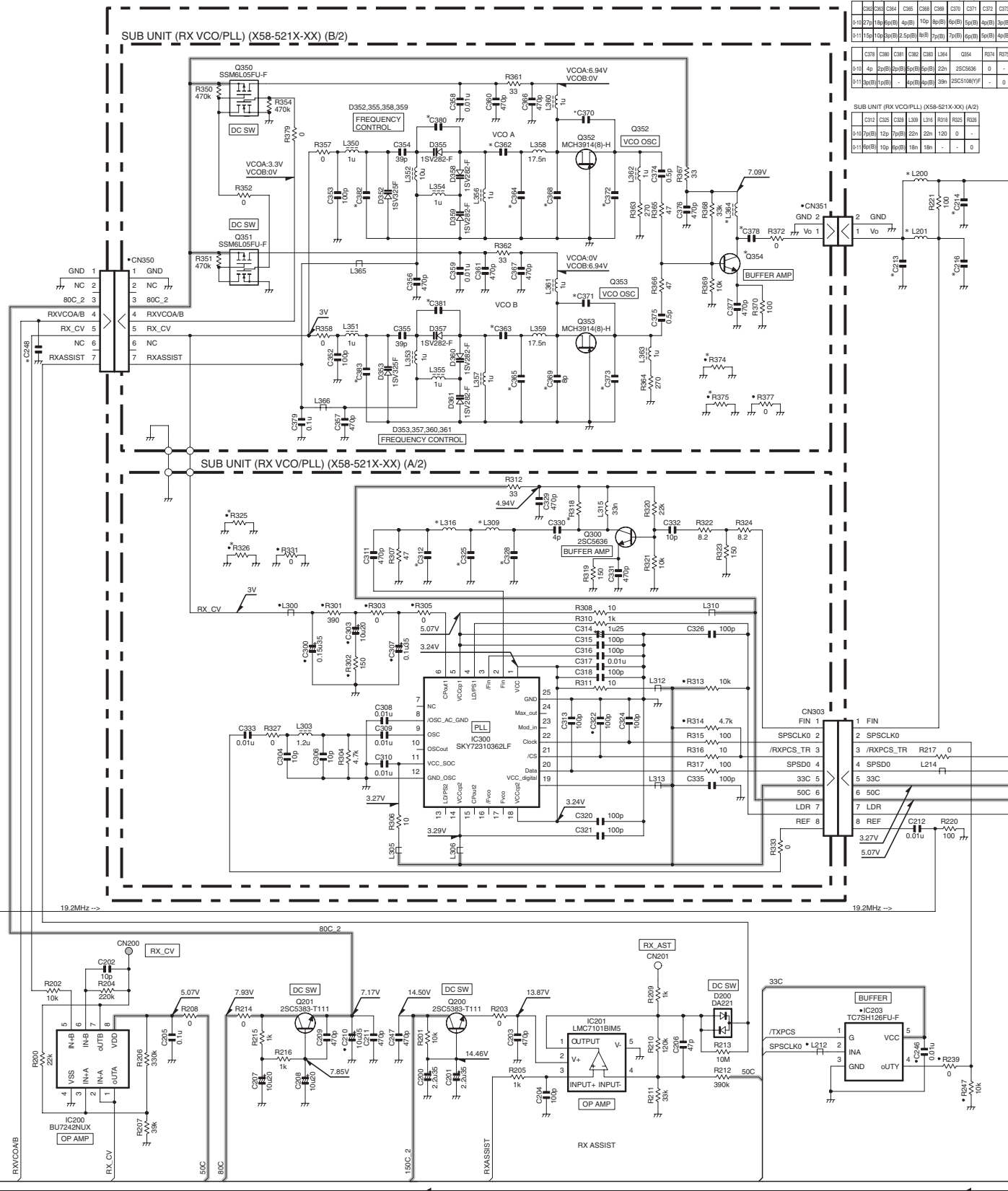

TKR-D810 SCHEMATIC DIAGRAM

TX-RX UNIT (X57-897K-03)

TX-RX UNIT (X57-897K-XX)

C101	C102	C103	C105	C107	C108	C111	C112	C113	C115	C117	C121	C123	C135	C136	C138	C140	C141	C143	C144	C145	C147	C150	C151	C158	C161	C162	C163	C164	C165	C167	C168	C169	C170	C171	C172	C173
K-03	56p	6p(B)	15p(G)	8p(B)	12p(G)	12p(G)	9p(B)	18p(G)	10p(B)	9p(B)	5p(B)	6p(B)	0.1u	5p(B)	12p(G)	18p(G)	10p(G)	10p(G)	9p(B)	12p(G)	12p(G)	9p(B)	15p(G)	5p(B)	8p(B)	560p	5p(B)	5p(B)	6p(B)	5p(B)	6p(B)	6p(B)	56p	6p(B)	6p(B)	3p(B)
K-02	3.5p(B)	1.5p(B)	1.5p(B)	8p(B)	3p(B)	3p(B)	33p	33p	10p(B)	7p(B)	-	12p	-	-	-	470p	100p	22p(G)	1p(B)	9p(B)	22p	8p(B)	7p(B)	6p(B)	12p(G)	10p	5p	-	-	-	-	22p(G)	4p(B)	7p(B)	3.5p(B)	

C173	C174	C175	C213	C214	C216	C232	C233	C234	C237	C239	C340	C241	C242	C244	C248	C249	C326	C328	C333	C346	C352	C353	C354	C355	C358	C551	C662	C664	C665	C668	C671	C674	C677	C690	C691	
K-03	3p(B)	4p(B)	5p(B)	10p(B)	5p(B)	5p(B)	-	47p	47p	8p(B)	-	470p	8p(B)	2p(B)	1p(B)	-	-	33p(G)	2p(B)	12p	18p	10p	18p	9p(B)	-	10p	-	7p(B)	3.5p(B)	-	-	4p(B)	4p(B)	6p(B)	-	-
K-02	3.5p(B)	1.5p(B)	1.5p(B)	8p(B)	3p(B)	3p(B)	2p(B)	33p	33p	10p(B)	7p(B)	-	12p	-	-	-	470p	100p	22p(G)	1p(B)	9p(B)	22p	8p(B)	7p(B)	6p(B)	12p(G)	10p	5p	-	-	-	-	22p(G)	4p(B)	7p(B)	3.5p(B)

C842	C843	C844	C845	C846	CN103	L107	L109	L120	L121	L200	L201	L206	L208	L209	L210	L303	L308	L310	L607	L608	L609	L610	L611	L619	Q202	Q203	Q606		
K-03	-	-	-	-	-	12n	6.8n	18n	18n	27n	27n	100n	-	15n	18n	330n	22n	330n	18n	18n	12n	27n	15n	-	-	2SC5636	2SC5636	2SC5636	
K-02	470p	470p	470p	100p	100p	E23-1330-05	10n	5.6n	15n	15n	22n	22n	150n	12n	12n	12n	390n	18n	270n	22n	22n	15n	22n	-	-	L92-0163-05	2SC5108(Y)F	2SC5108(Y)F	2SC4725

R223	R246	R311	R312	R323	R444	R523	R617	R663	R688	R689	R690	R857	R861	
K-03	330	220	10	10	150	1.2k	0	150k	0	33	180	180	-	0
K-02	180	330	22	22	180	820	150	150k	-	68	100	100	0	-

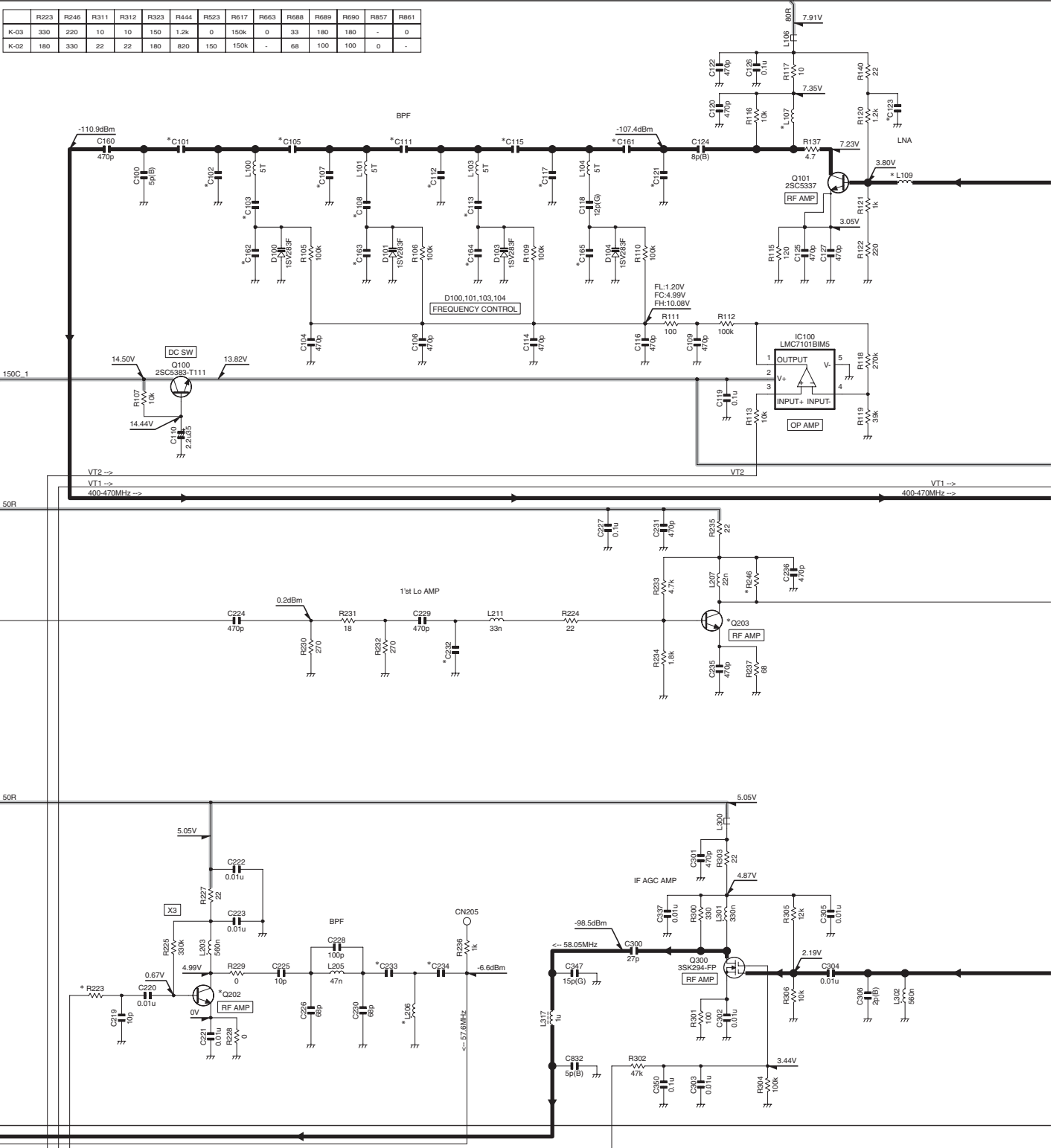

SCHEMATIC DIAGRAM TKR-D810

TX-RX UNIT (X57-897K-03)

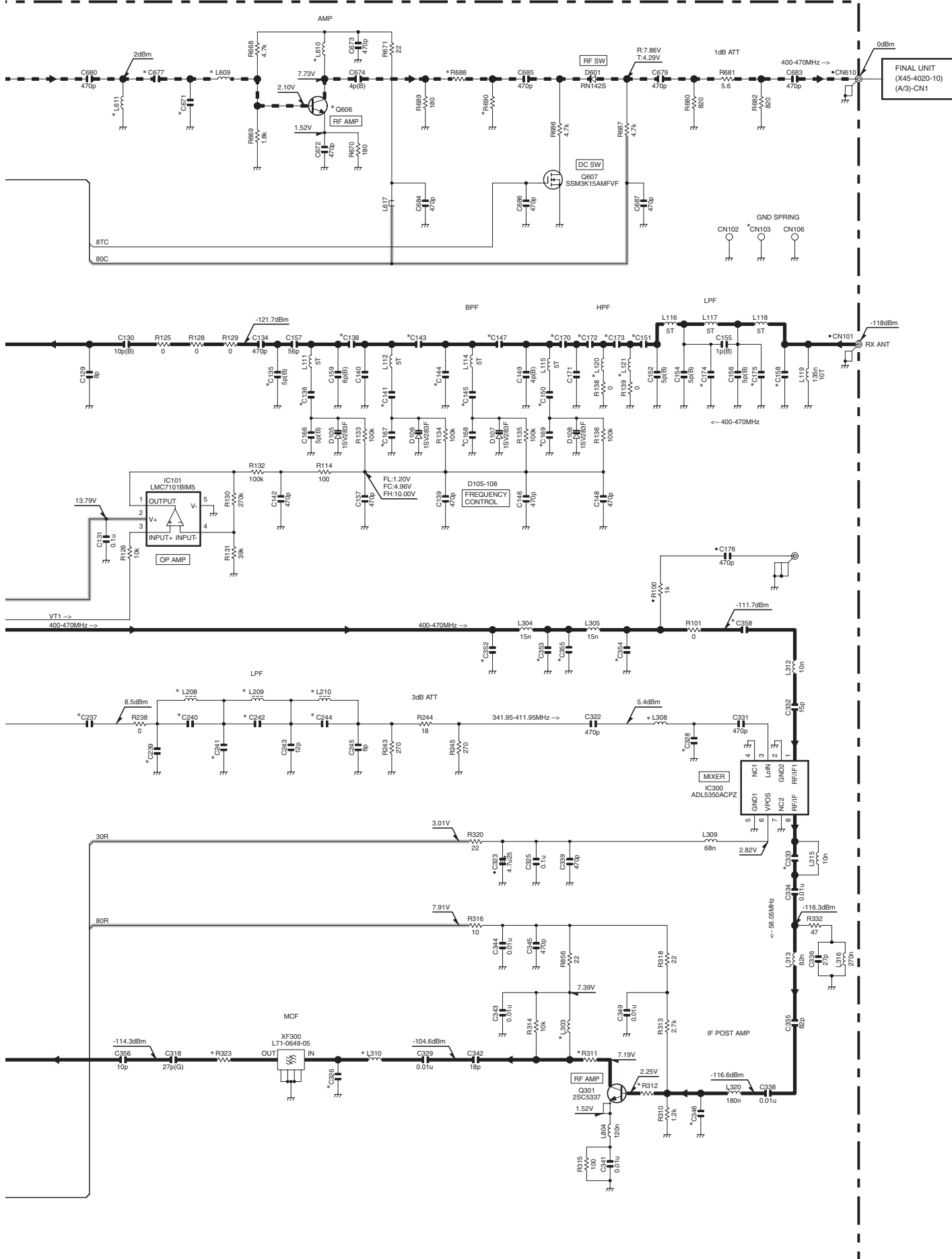

Note : The components marked with a dot (●) are parts of layer 1.

TKR-D810 BLOCK DIAGRAM

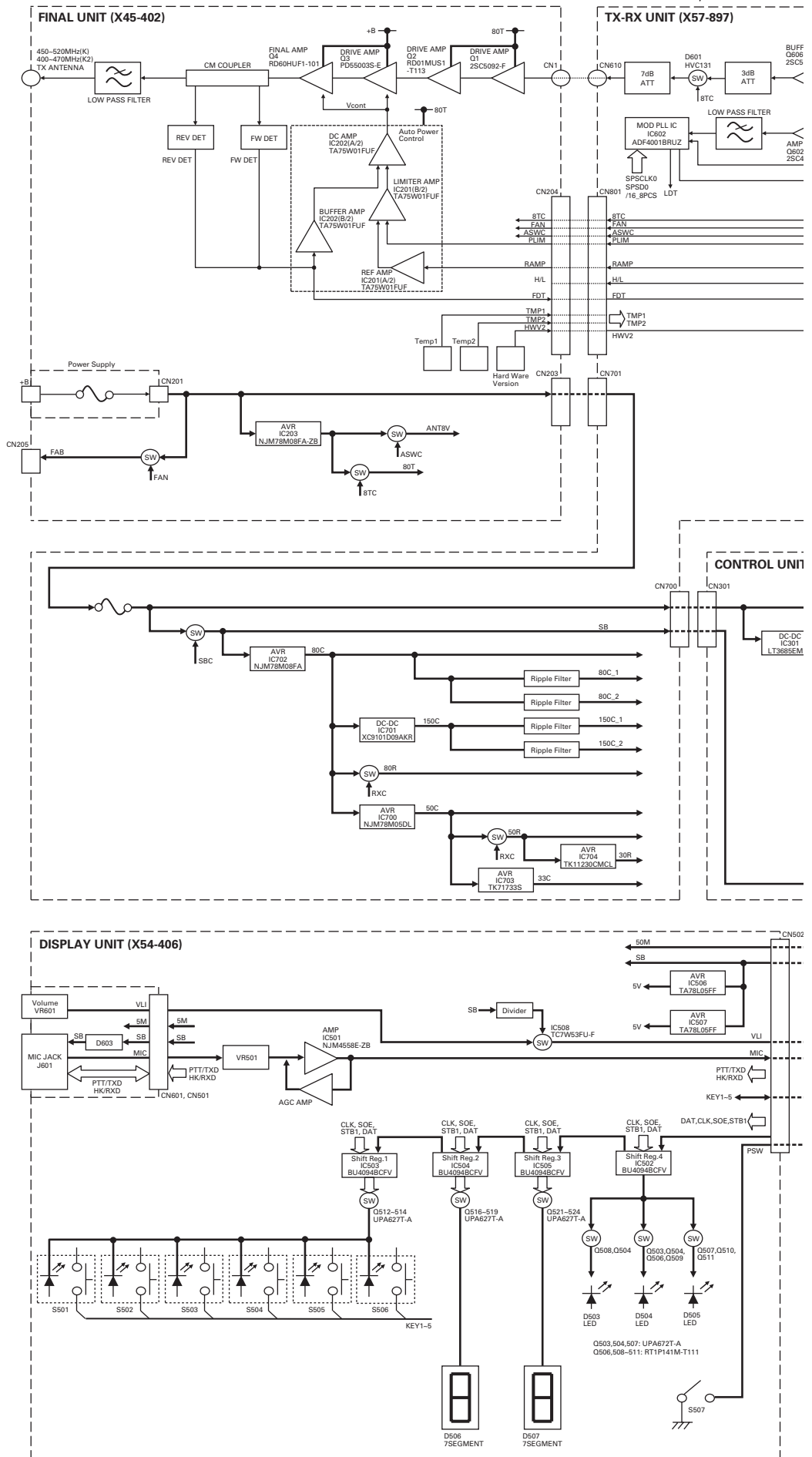

BLOCK DIAGRAM TKR-D810

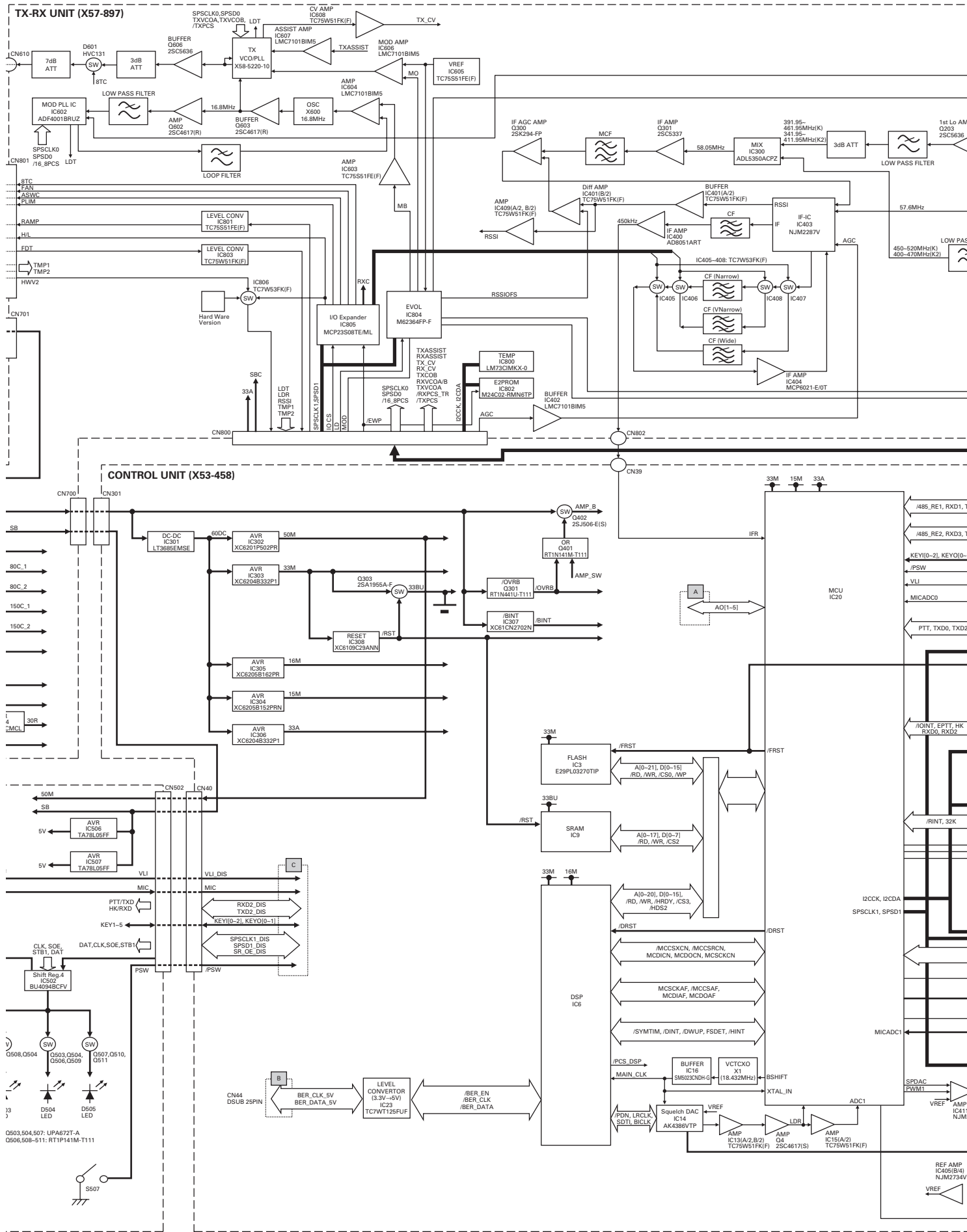

TKR-D810 BLOCK DIAGRAM

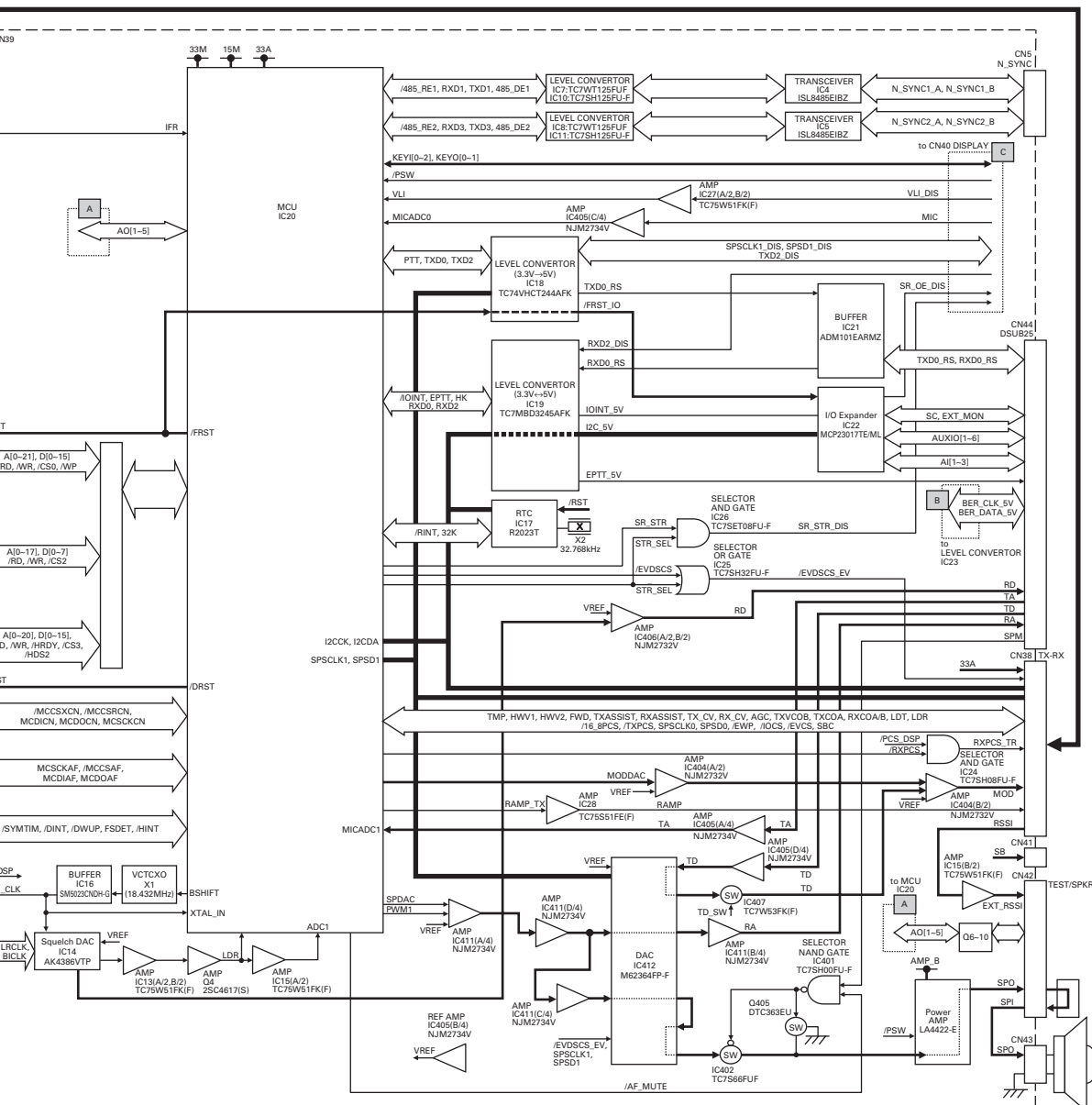
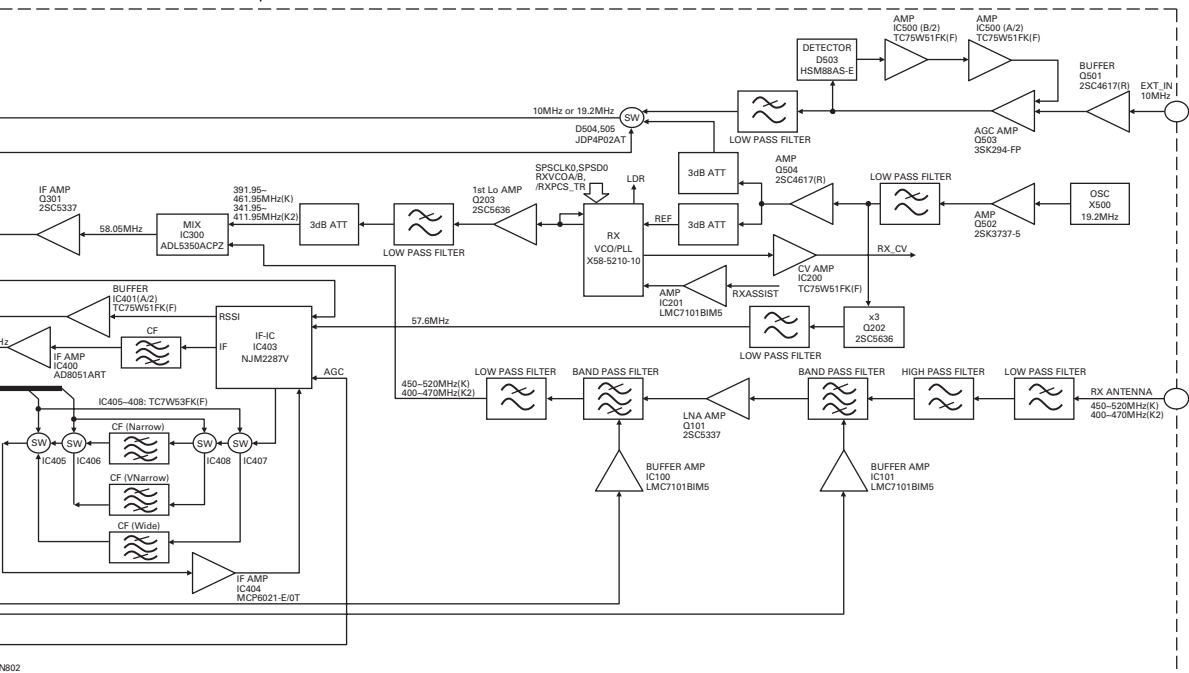

OPTIONAL ACCESSORIES: KES-5 (EXTERNAL SPEAKER)

When Using an External Speaker

1. Make sure the unit's power is tuned off.
2. When using the external speaker, remove the jumper lead from the connector, and attach the speaker cable.
3. When not using the external speaker, replace the jumper lead and insert the connector into the speaker jack (pin 9 and 12).

Specifications

Maximum input power	40W
Impedance	4Ω
Dimensions (W x H x D) projection not included	129 x 129 x 77 mm
Weight	820g

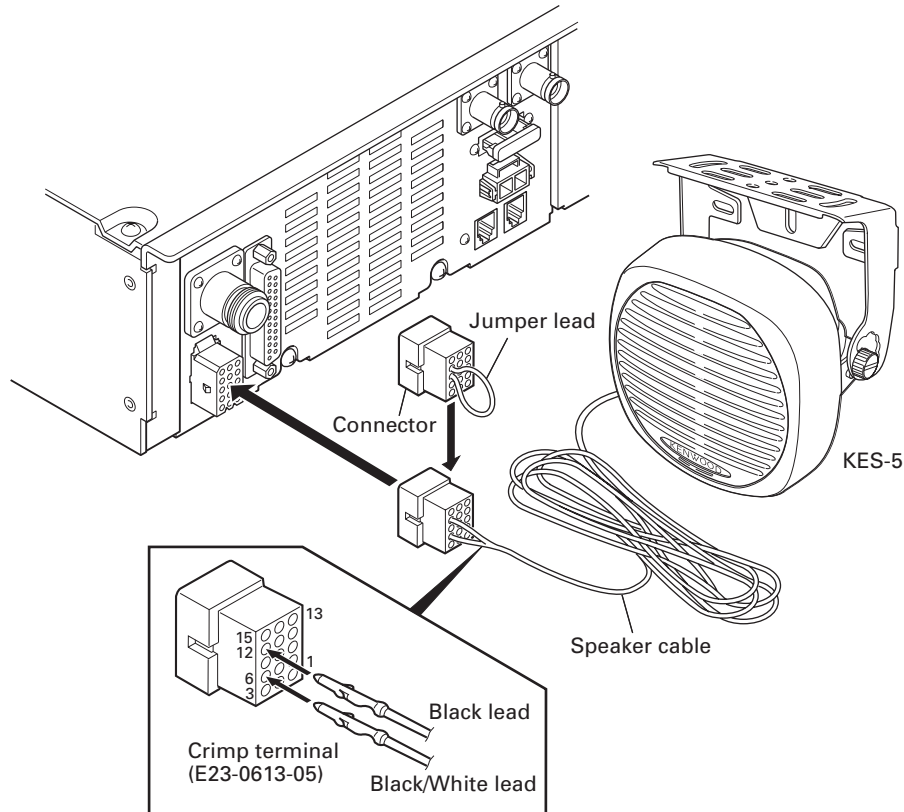

SPECIFICATIONS

General

Frequency Ranges	450~520MHz(K), 400~470MHz(K2)
Number of Channels.....	30
Channel Spacing	
Analogue	12.5/ 25kHz
Digital.....	12.5kHz
PLL Channel Step.....	3.125/ 5kHz
Antenna Impedance	50Ω
Operating Voltage	13.6V DC (10.8~15.6V DC)
Current Drain	
Standby.....	0.5A
Receive	1.0A
Transmit.....	11.0A
Duty Cycle (TX, RX)	100% at 25W, 50% at maximum power
Operating Temperature Range	-30°C~+60°C
Frequency Stability	±1.0ppm
Dimension (W x H x D) (Projections not included).....	482.6 x 88 x 340 mm
Weight (net).....	9.7kg

Receiver

Sensitivity (Analogue)	
EIA 12dB SINAD	0.28μV
Sensitivity (Digital)	
5% BER	12.5kHz: 0.25μV
1% BER	12.5kHz: -3dBμV (0.35μV)
Adjacent Channel Selectivity (Analogue)	25kHz: 80dB, 12.5kHz: 74dB
Intermodulation (Analogue)	80dB
Spurious Respons Rejection (Analogue).....	90dB
Audio Distortion.....	Less than 2.5% at 1000Hz
Audio Output	4W (at 4Ω, less than 5% distortion)

Transmitter

RF Power Output.....	5~40W
Modulation Limiting (Analogue).....	±5.0kHz at 25kHz, ±2.5kHz at 12.5kHz
Spurious Emission	80dB
FM Noise (EIA) (Analogue)	25kHz: 55dB, 12.5kHz: 50dB
Modulation Distortion	Less than 1% at 1000Hz
Modulation.....	16K0F3E, 11K0F3E, 7K60FXE, 7K60FXD

Analog measurements made per TIA/EIA 603 and specifications shown are typical.

JVC KENWOOD Corporation reserves the right to change specifications without prior notice or obligation.



KENWOOD

JVKENWOOD Corporation
Communications Systems Business Operation

TKR-D810 PC BOARD

PC BOARD TKR-D810

FINAL UNIT (X45-4020-10(TKR-D810K2),X45-4020-11(TKR-D810K))
Component side view (J79-0264-19)

FINAL UNIT (X45-4020-10(TKR-D810K2),X45-4020-11(TKR-D810K))
Component side view (J79-0264-19)

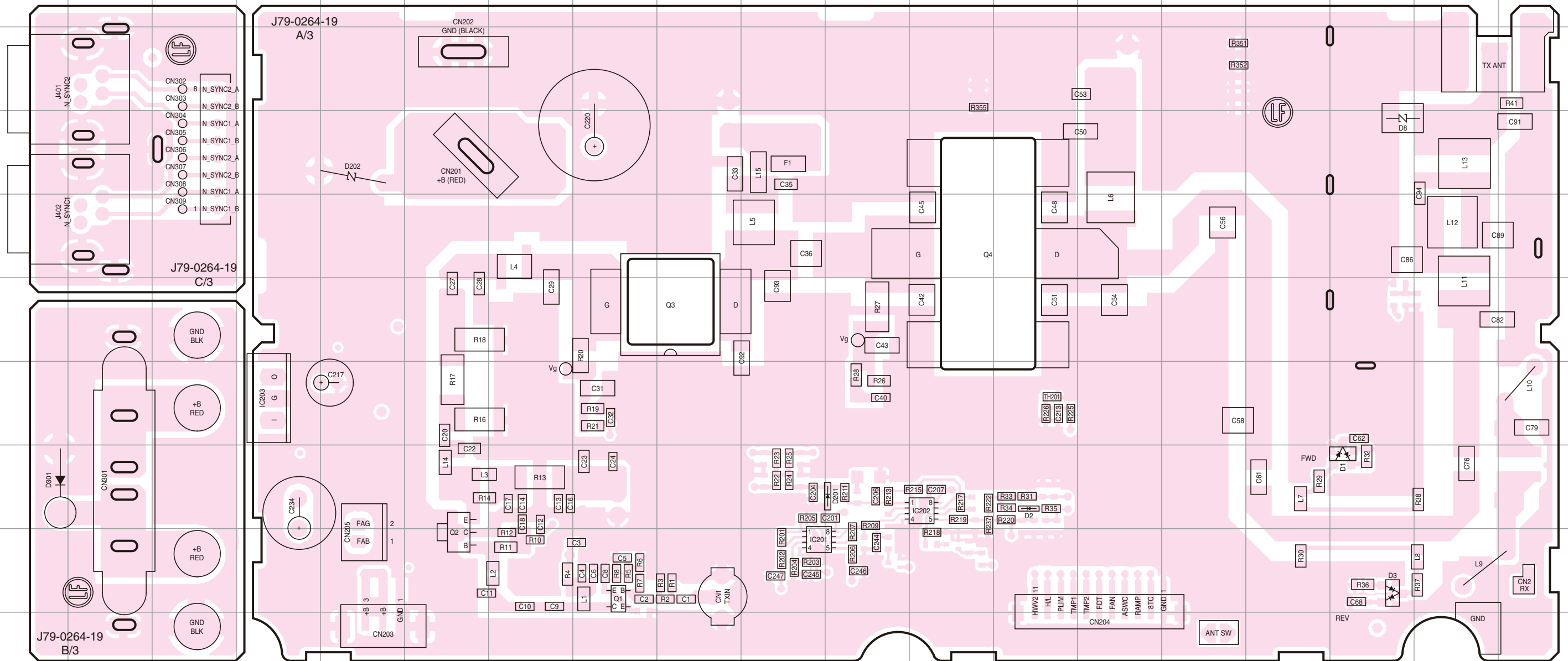

Ref. No.	Address	Ref. No.	Address
IC201	9J	D1	8Q
IC202	8L	D2	8M
IC203	7D	D3	9Q
Q1	9H	D8	4Q
Q2	9F	D201	8K
Q3	6I	D202	4E
Q4	5L	D301	8A

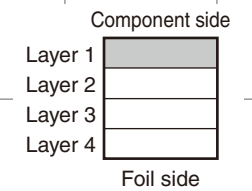

TKR-D810 PC BOARD

PC BOARD TKR-D810

FINAL UNIT (X45-4020-10(TKR-D810K2),X45-4020-11(TKR-D810K))
Foil side view (J79-0264-19)

FINAL UNIT (X45-4020-10(TKR-D810K2),X45-4020-11(TKR-D810K))
Foil side view (J79-0264-19)

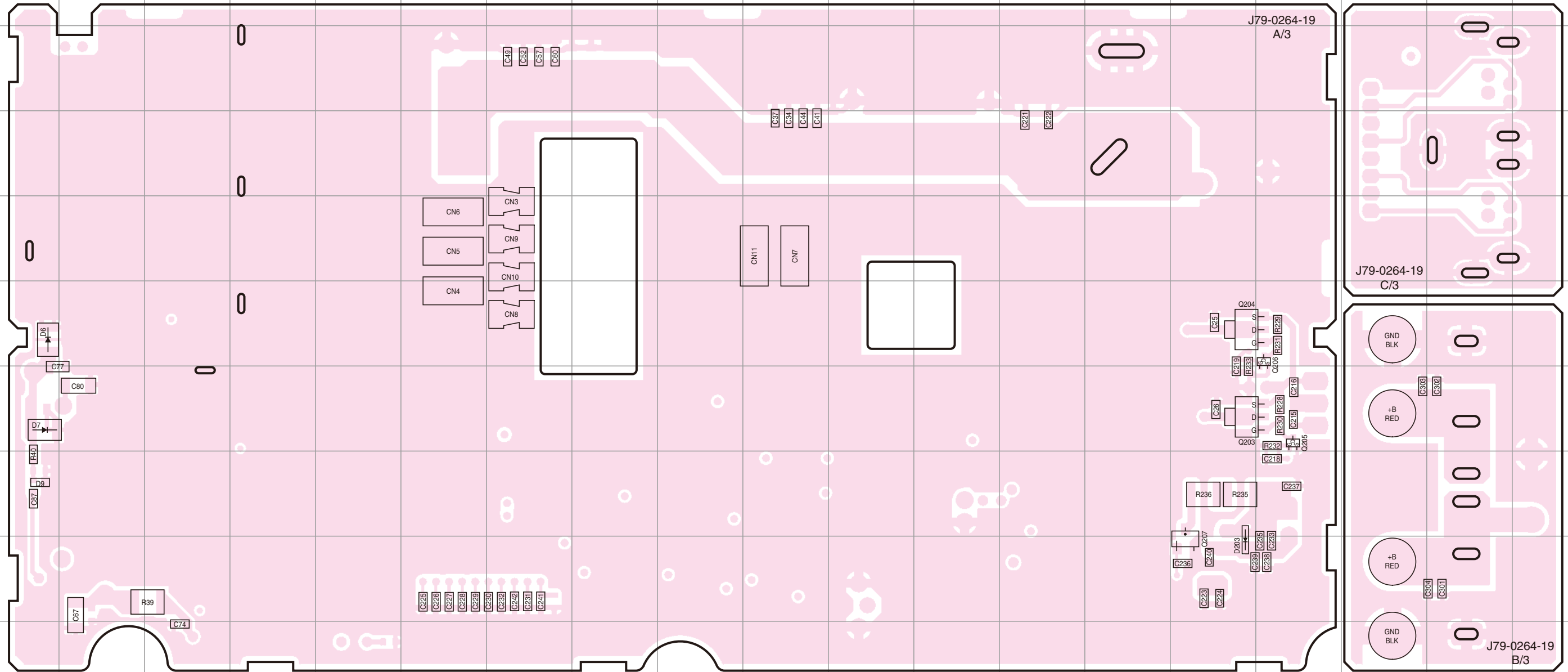

Ref. No.	Address
Q203	7O
Q204	6O
Q205	7P
Q206	6P
Q207	9O
D6	6A
D7	7A
D203	9O

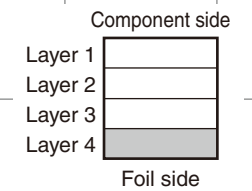

TKR-D810 PC BOARD

PC BOARD TKR-D810

CONTROL UNIT (X53-4580-10)
Component side view (J79-0277-19)

CONTROL UNIT (X53-4580-10)
Component side view (J79-0277-19)

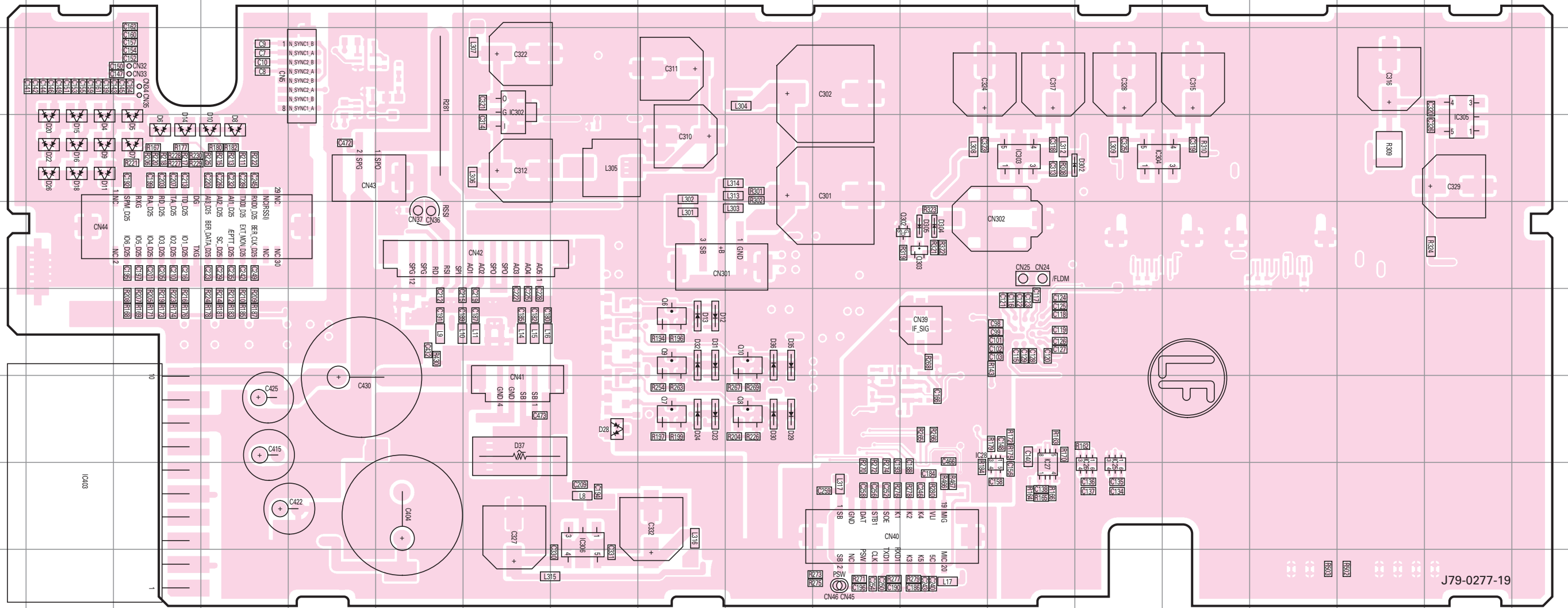

Ref. No.	Address	Ref. No.	Address	Ref. No.	Address	Ref. No.	Address	Ref. No.	Address
IC25	8N	Q6	6I	D7	4C	D18	4B	D32	6I
IC26	8N	Q7	7I	D8	4D	D20	4B	D35	6J
IC27	8M	Q8	7J	D9	4B	D22	4B	D36	6J
IC28	8M	Q9	6I	D10	4D	D23	7I	D37	7G
IC302	3G	Q10	6J	D11	4B	D24	7I	D302	4N
IC303	4M	Q302	5L	D12	6I	D26	4B	D304	5L
IC304	4N	Q303	5L	D13	6I	D28	7H	D305	5L
IC305	4R	D4	4B	D14	4C	D29	7J		
IC306	8H	D5	4C	D15	4B	D30	7J		
IC403	8B	D6	4C	D16	4B	D31	6I		

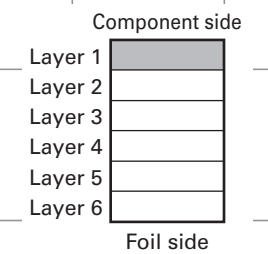

TKR-D810 PC BOARD

PC BOARD TKR-D810

CONTROL UNIT (X53-4580-10)
Foil side view (J79-0277-19)

CONTROL UNIT (X53-4580-10)
Foil side view (J79-0277-19)

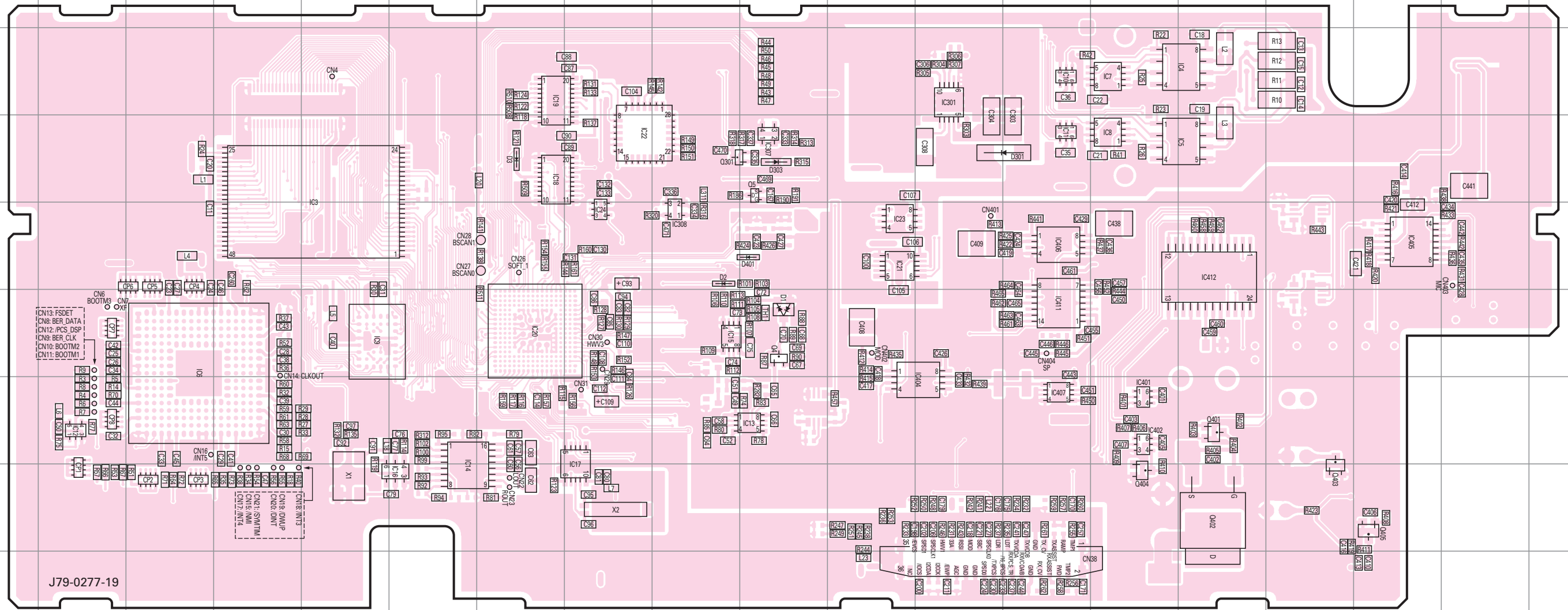

Ref. No.	Address	Ref. No.	Address	Ref. No.	Address	Ref. No.	Address	Ref. No.	Address
IC3	4E	IC13	7J	IC23	5K	IC407	7M	Q405	8Q
IC4	3O	IC14	8F	IC24	5H	IC411	6M	D1	6J
IC5	4O	IC15	6I	IC301	3L	IC412	5O	D2	5I
IC6	6C	IC16	8F	IC307	4J	Q4	6J	D3	4G
IC7	3N	IC17	8H	IC308	5I	Q5	4J	D301	4M
IC8	4N	IC18	4G	IC401	7N	Q301	4I	D303	4J
IC9	6E	IC19	3G	IC402	7N	Q401	7O	D401	5J
IC10	3M	IC20	6G	IC404	7L	Q402	8O		
IC11	4M	IC21	5K	IC405	5Q	Q403	8P		
IC12	7B	IC22	4H	IC406	5M	Q404	8N		

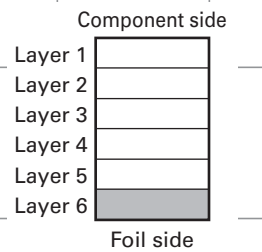

TKR-D810 PC BOARD

PC BOARD TKR-D810

DISPLAY UNIT (X54-4060-20) Component side view (J79-0295-09)

DISPLAY UNIT (X54-4060-20) Component side view (J79-0295-09)

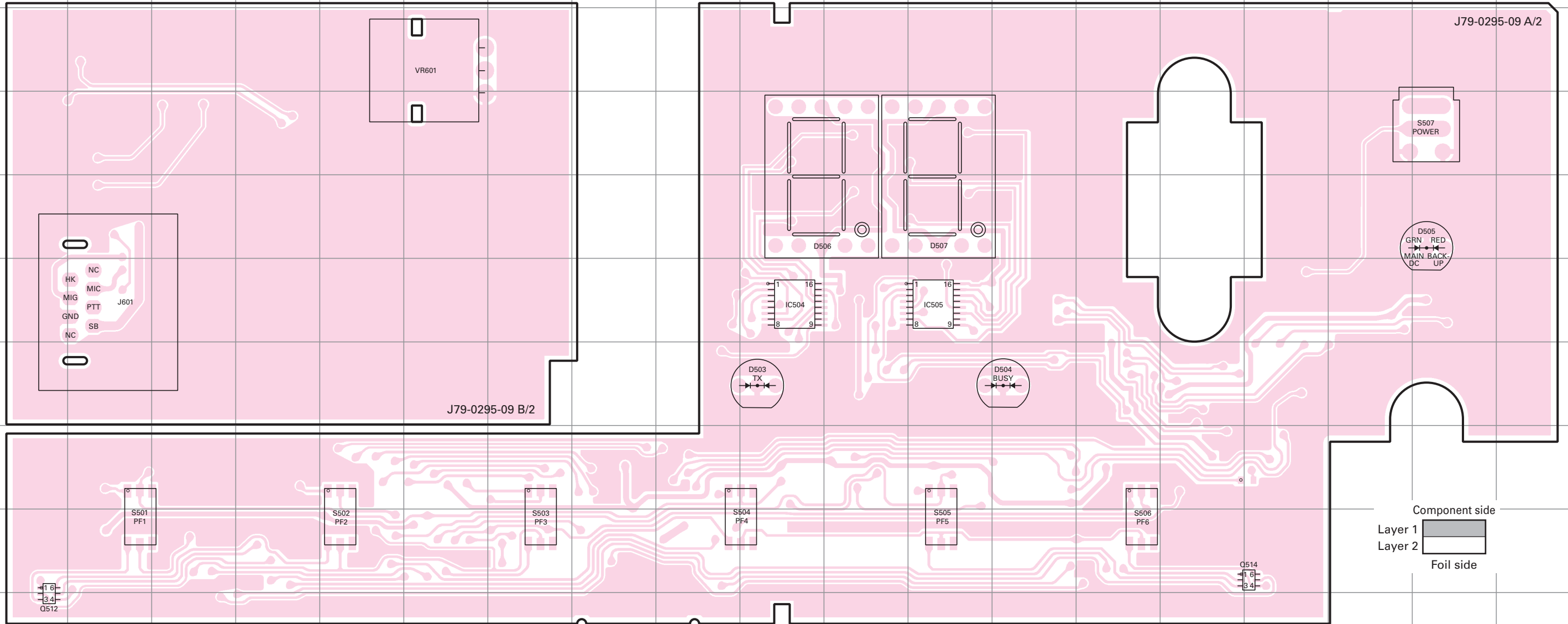

Component side
 Layer 1
 Layer 2
 Foil side

Ref. No.	Address
IC504	6J
IC505	6L
Q512	10A
Q514	9P
D503	7J
D504	7M
D505	5R
D506	5J
D507	5L

DISPLAY UNIT (X54-4060-20) Foil side view (J79-0295-09)

DISPLAY UNIT (X54-4060-20) Foil side view (J79-0295-09)

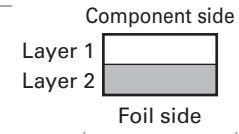
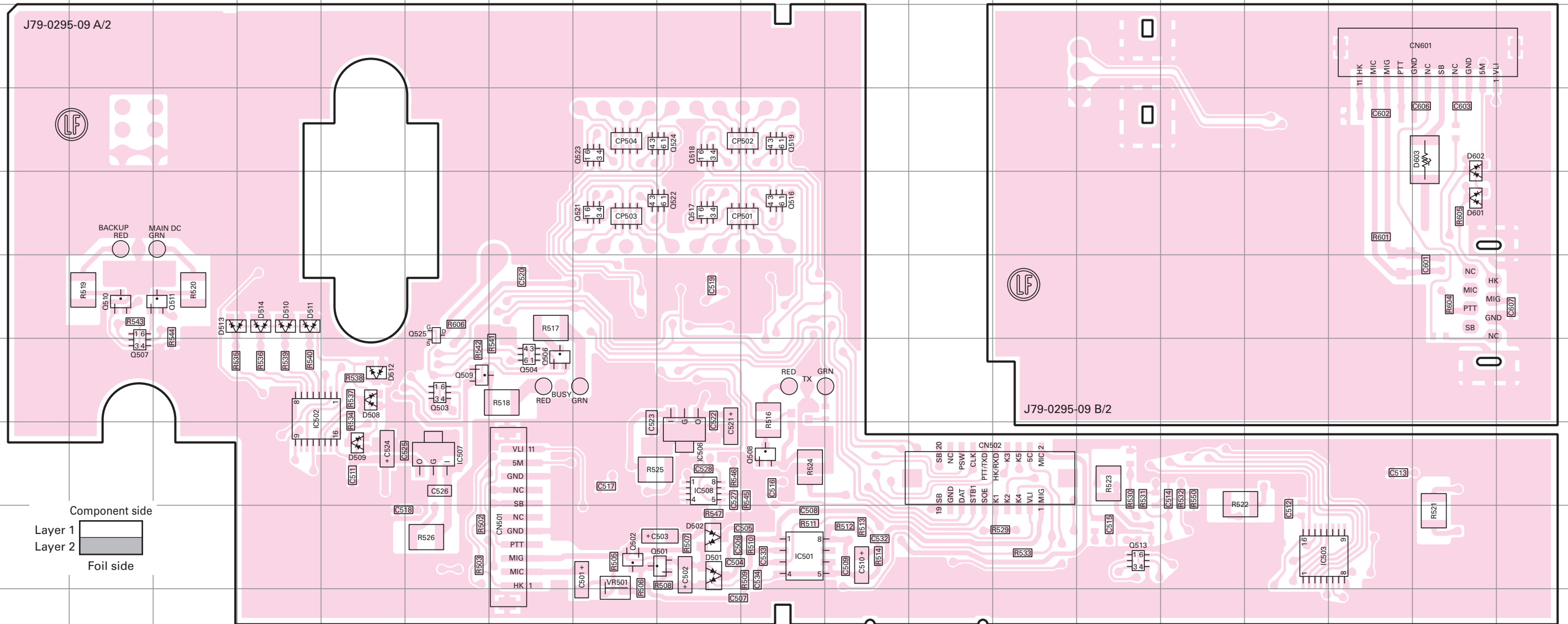

Ref. No.	Address	Ref. No.	Address	Ref. No.	Address	Ref. No.	Address
IC501	9J	Q506	7G	Q519	4J	D510	6D
IC502	7D	Q507	7B	Q521	5H	D511	6D
IC503	9P	Q508	8J	Q522	5I	D512	7E
IC506	8I	Q509	7F	Q523	4H	D513	6C
IC507	8F	Q510	6B	Q524	4I	D514	6D
IC508	8I	Q511	6C	Q525	6F	D601	5R
Q501	9I	Q513	9N	D501	9I	D602	4R
Q502	9H	Q516	5J	D502	9I	D603	4R
Q503	7F	Q517	5I	D508	7E		
Q504	7G	Q518	4I	D509	8E		

TKR-D810 PC BOARD

PC BOARD TKR-D810

TX-RX UNIT (X57-897K-03(TKR-D810(K2)),X57-897K-02(TKR-D810(K))
Component side view (J7C-0066-00)

TX-RX UNIT (X57-897K-03(TKR-D810(K2)),X57-897K-02(TKR-D810(K))
Component side view (J7C-0066-00)

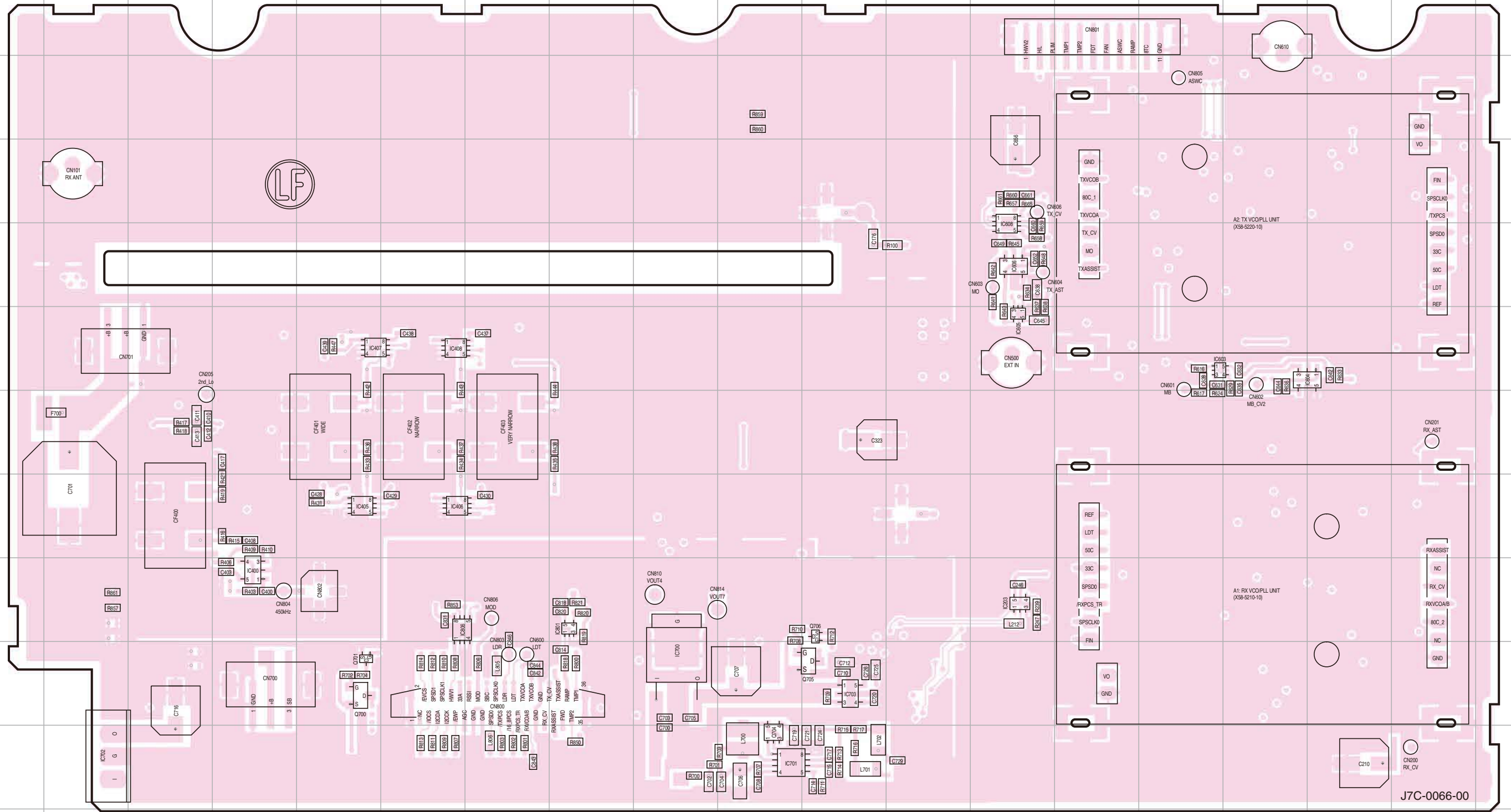

Ref. No.	Address	Ref. No.	Address	Ref. No.	Address	Ref. No.	Address
IC203	9M	IC603	6O	IC701	11J	Q701	10E
IC400	9D	IC604	6P	IC702	11B	Q704	11J
IC405	8E	IC605	6M	IC703	10K	Q705	10K
IC406	8F	IC606	5M	IC801	9H	Q706	9K
IC407	6E	IC608	5M	IC806	9F		
IC408	6F	IC700	10I	Q700	10E		

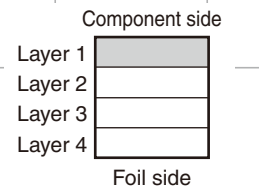

TKR-D810 PC BOARD

PC BOARD TKR-D810

TX-RX UNIT (X57-897K-03(TKR-D810(K2)),X57-897K-02(TKR-D810(K))
Foil side view (J7C-0066-00)

TX-RX UNIT (X57-897K-03(TKR-D810(K2)),X57-897K-02(TKR-D810(K))
Foil side view (J7C-0066-00)

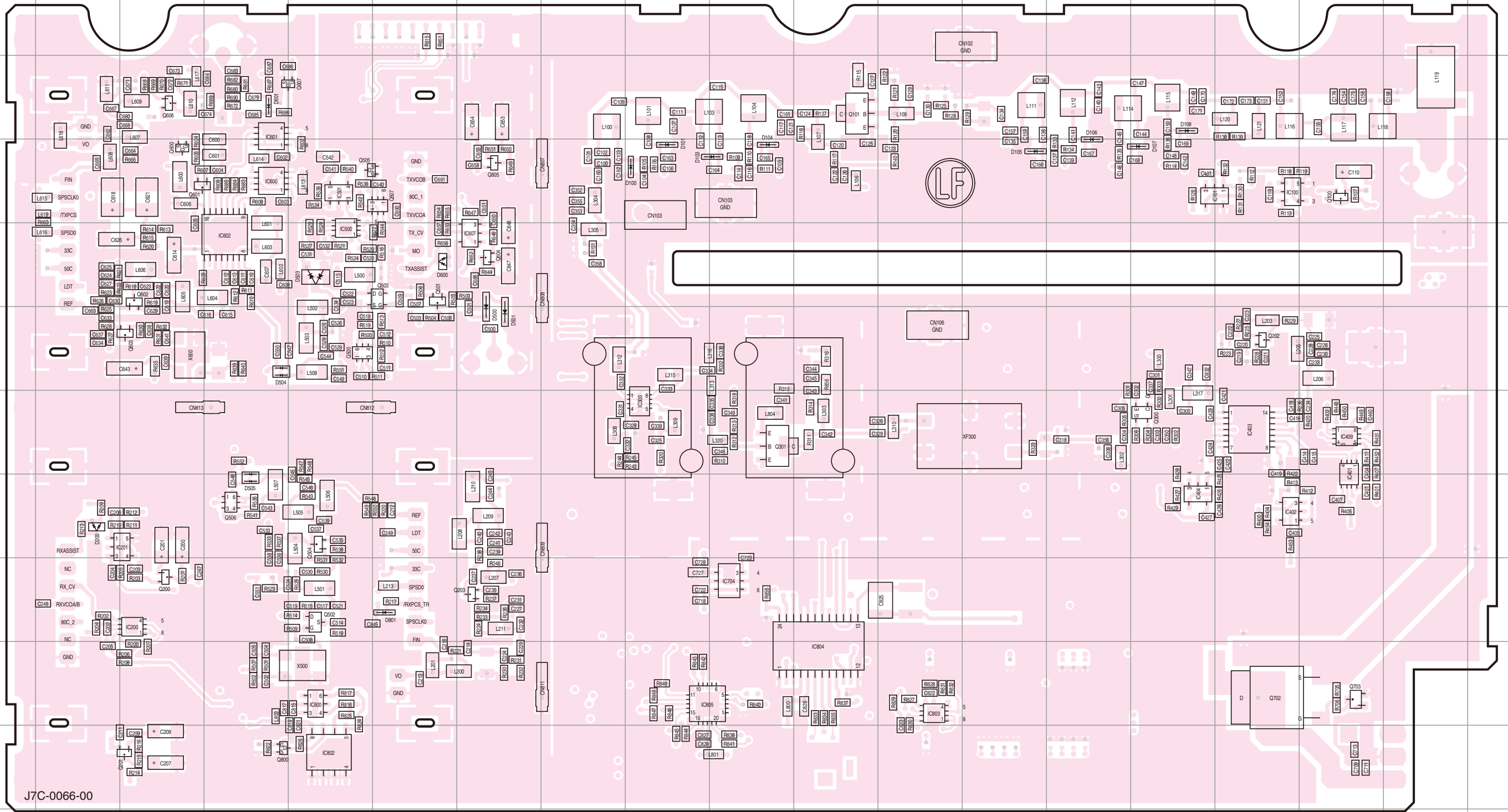

J7C-0066-00

Ref. No.	Address	Ref. No.	Address	Ref. No.	Address	Ref. No.	Address	Ref. No.	Address	Ref. No.	Address	Ref. No.	Address	Ref. No.	Address	Ref. No.	Address	Ref. No.	Address		
IC100	4P	IC402	8P	IC600	4D	IC802	11E	Q200	9C	Q500	6E	Q506	8D	Q604	5G	Q800	11D	D106	3N	D503	5E
IC101	4O	IC403	7P	IC601	3D	IC803	10L	Q201	11C	Q501	5F	Q507	4F	Q605	4G	D100	4I	D107	4O	D504	6D
IC200	9C	IC404	8O	IC602	5D	IC804	10K	Q202	6P	Q502	9E	Q600	4C	Q606	3C	D101	4I	D108	3O	D505	8D
IC201	8C	IC409	7Q	IC607	5G	IC805	10I	Q203	9G	Q503	5F	Q601	4C	Q607	3E	D103	4I	D200	8B	D600	5F
IC300	7I	IC500	5E	IC704	9J	Q100	4Q	Q300	7O	Q504	8E	Q602	5C	Q702	10P	D104	3J	D500	6G	D601	3D
IC401	7Q	IC501	4E	IC800	10E	Q101	3K	Q301	7J	Q505	4E	Q603	6C	Q703	10Q	D105	4M	D501	6G	D801	9F

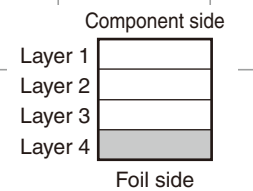

TKR-D810 PC BOARD

RX VCO/PLL UNIT (X58-5210-10(TKR-D810(K2)),X58-5210-11(TKR-D810(K))
 Component side view (J79-0269-09) Foil side view (J79-0269-09)

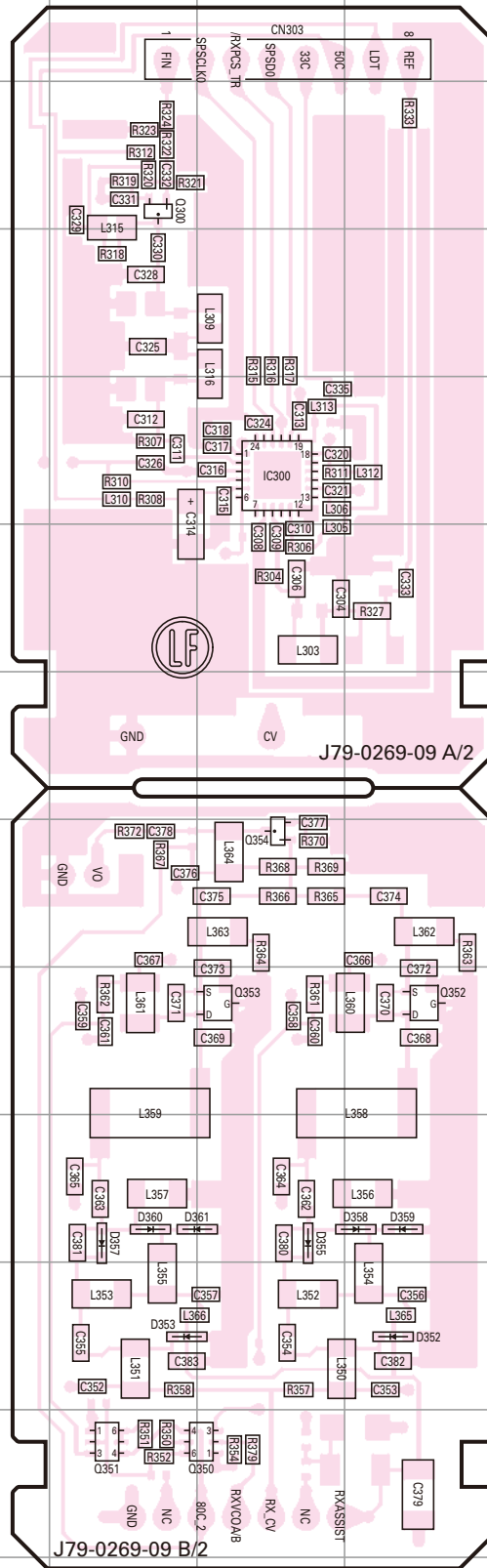
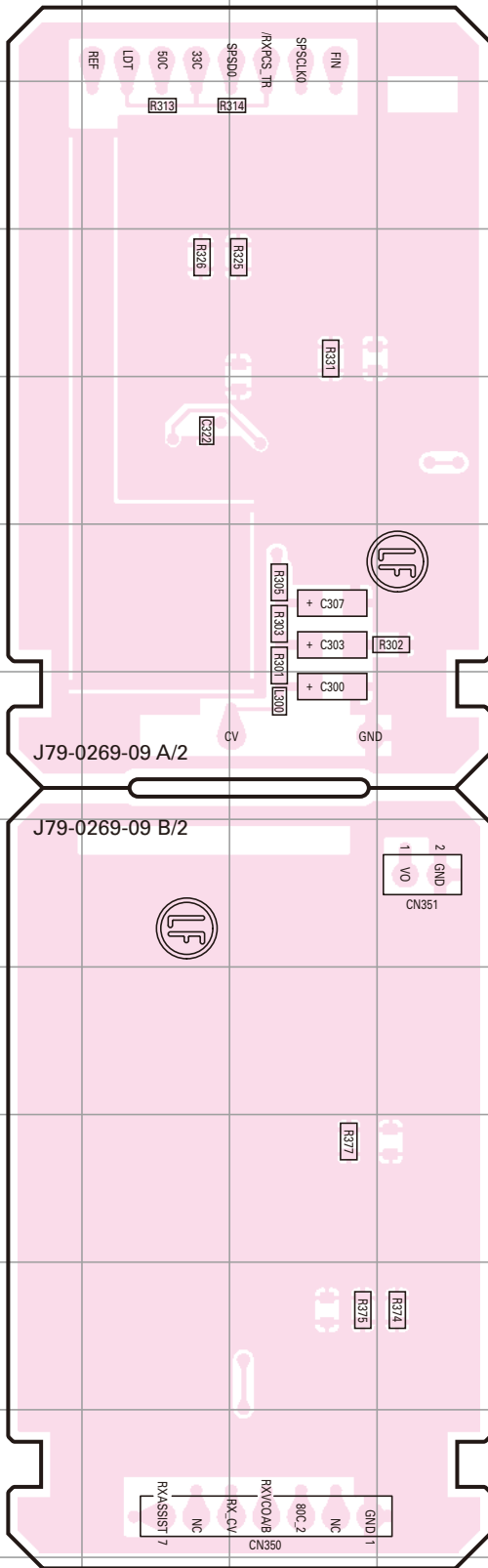

Ref. No.	Address
IC300	5G
Q300	3F
Q350	12G
Q351	12F
Q352	9H
Q353	9G
Q354	8G
D352	11H
D353	11F
D355	10G
D357	10F
D358	10H
D359	10H
D360	10F
D361	10G

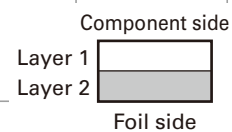
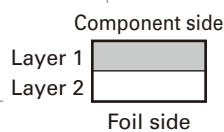

PC BOARD TKR-D810

TX VCO/PLL UNIT (X58-5220-10(TKR-D810(K2),X58-5220-11(TKR-D810(K))
 Component side view (J79-0270-09) Foil side view (J79-0270-09)

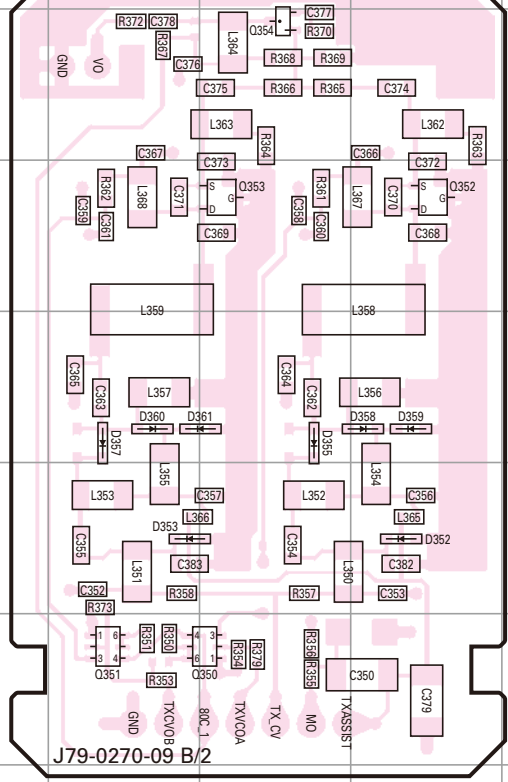
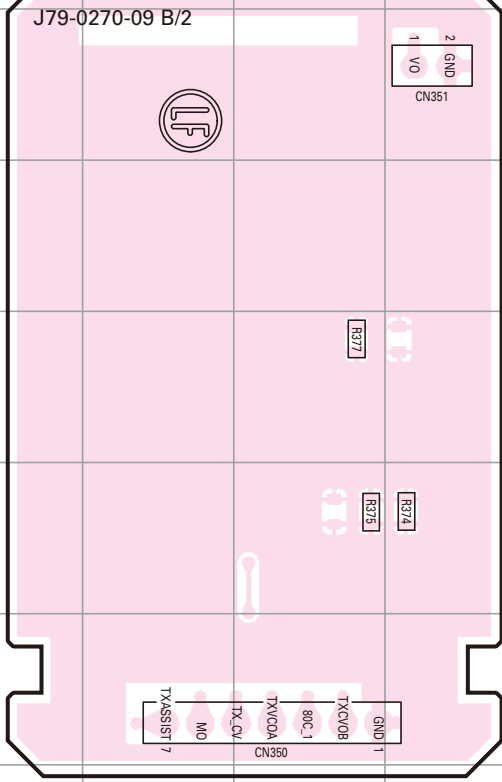
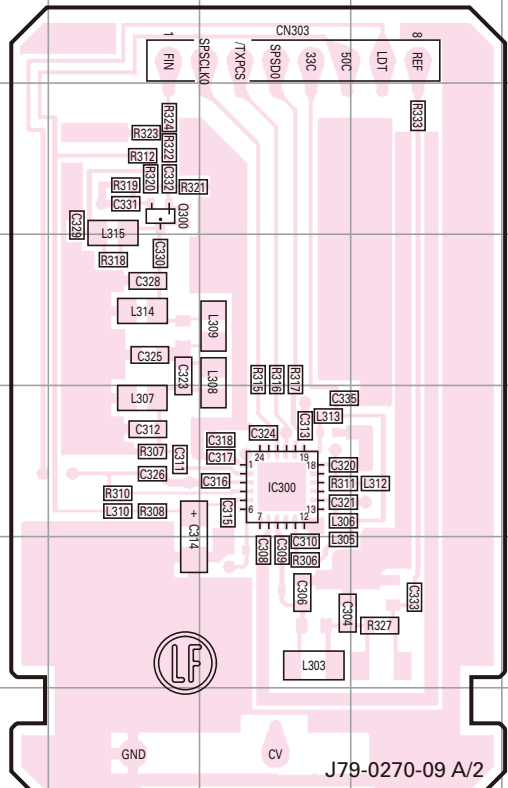
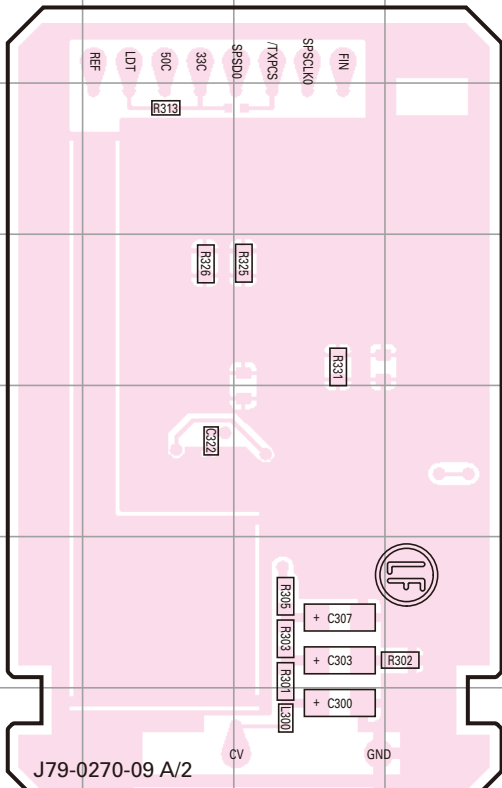

Ref. No.	Address
IC300	5G
Q300	3F
Q350	12G
Q351	12F
Q352	9H
Q353	9G
Q354	8G
D352	11H
D353	11F
D355	10G
D357	10F
D358	10H
D359	10H
D360	10F
D361	10G

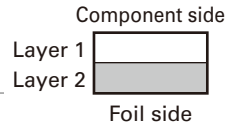
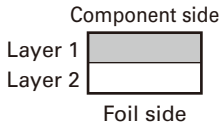

FINAL UNIT (X45-4020-10) (A/3)

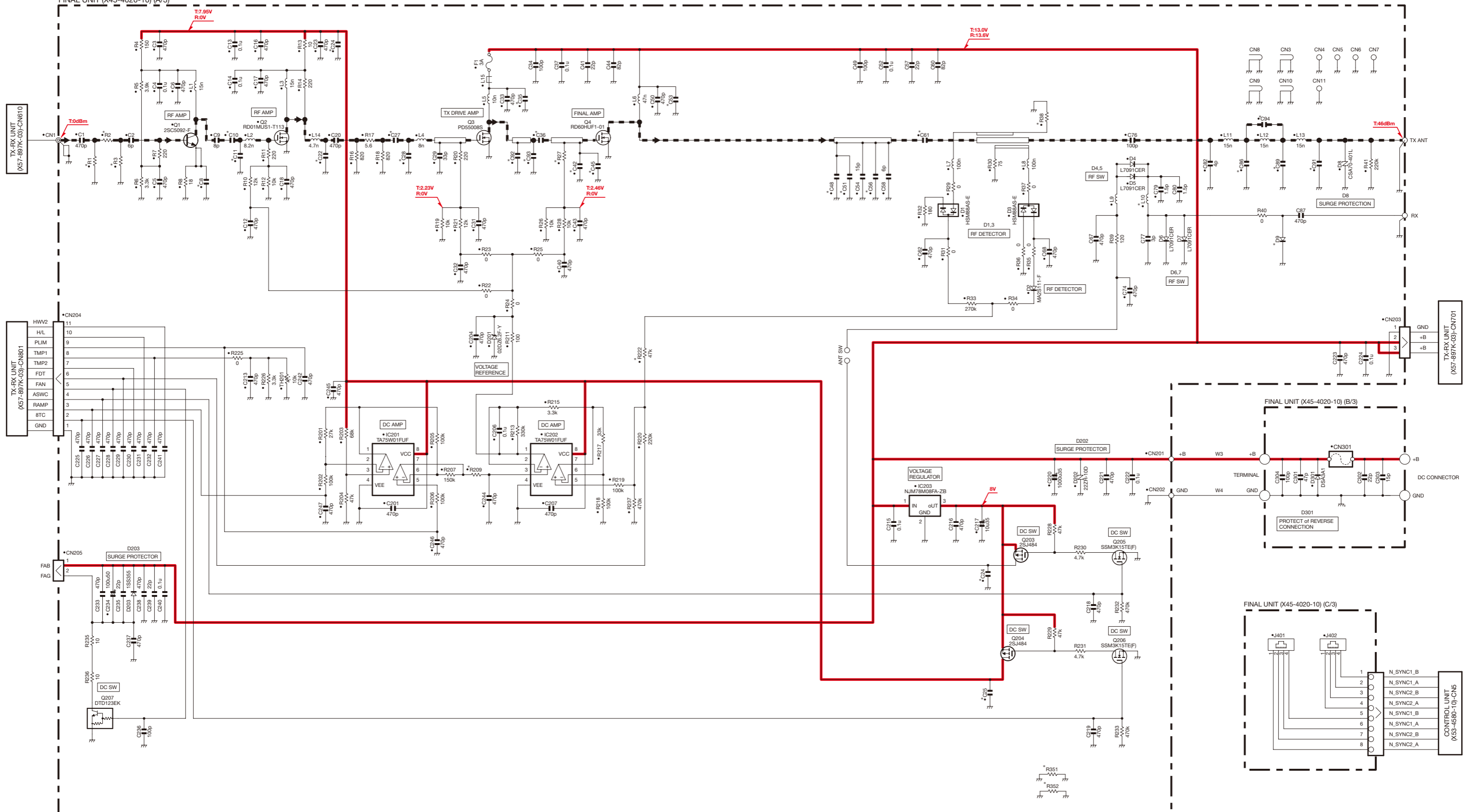

FINAL UNIT (X45-4020-10) (B/3)

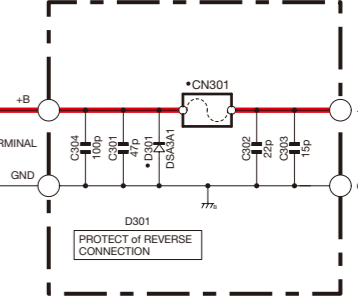

FINAL UNIT (X45-4020-10) (C/3)

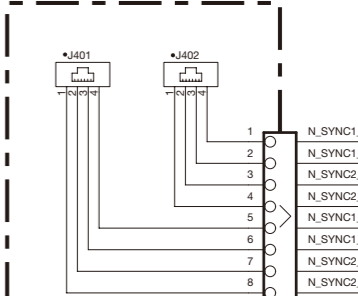

DISPLAY UNIT (X54-4060-20) (A/2)

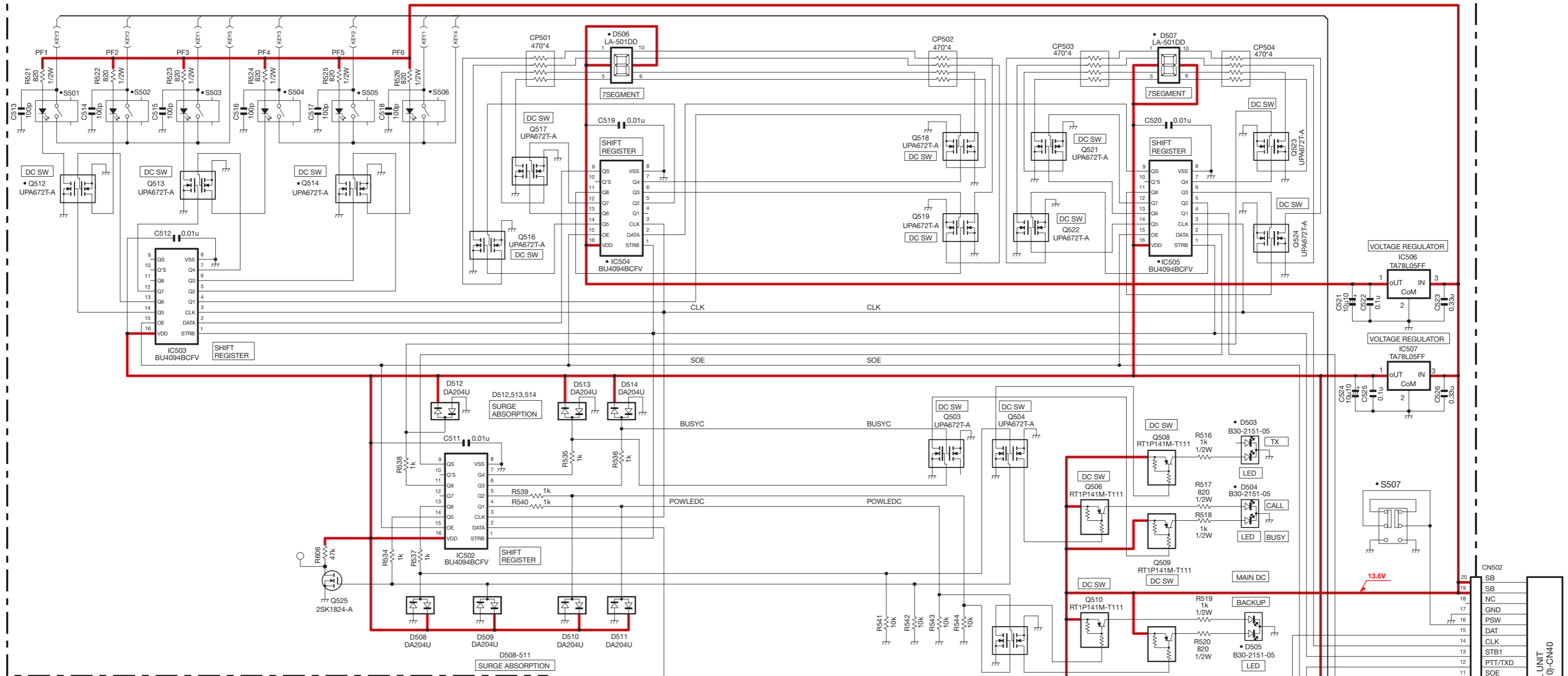

DISPLAY UNIT (X54-4060-20) (B/2)

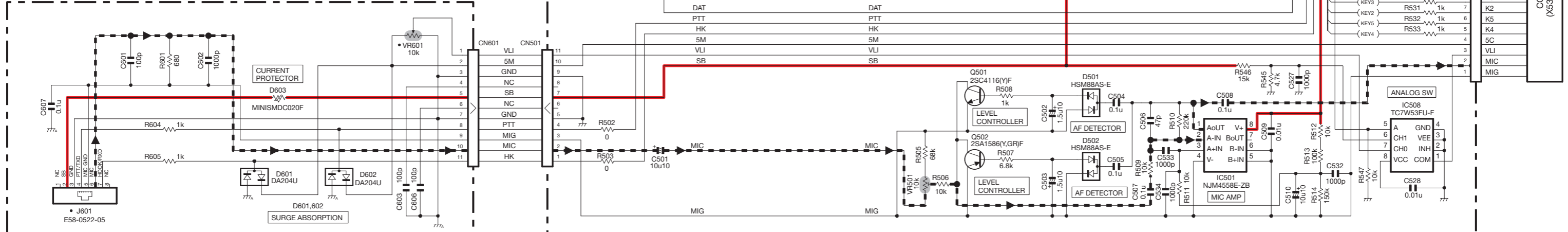

- | | | |
|---|----------|---------------|
| A | : | N09-2292-05 |
| B | M2.6 x 6 | : N30-2606-48 |
| C | M4 x 6 | : N30-4006-48 |
| D | M4 x 14 | : N30-4014-48 |
| E | M4 x 20 | : N30-4020-43 |
| F | M3 x 6 | : N32-3006-48 |
| G | M4 x 8 | : N32-4008-43 |
| H | M3 x 6 | : N35-3006-43 |
| J | M4 x 6 | : N35-4006-43 |
| K | M3 x 8 | : N67-3008-48 |
| L | ø2.6 x 8 | : N80-2608-43 |
| M | ø3 x 5 | : N87-3005-43 |
| N | ø3 x 6 | : N87-3006-48 |

