

TM-281A

SERVICE MANUAL

KENWOOD

Kenwood Corporation

© 2011-8 PRINTED IN JAPAN
B51-8988-00 (N) 217

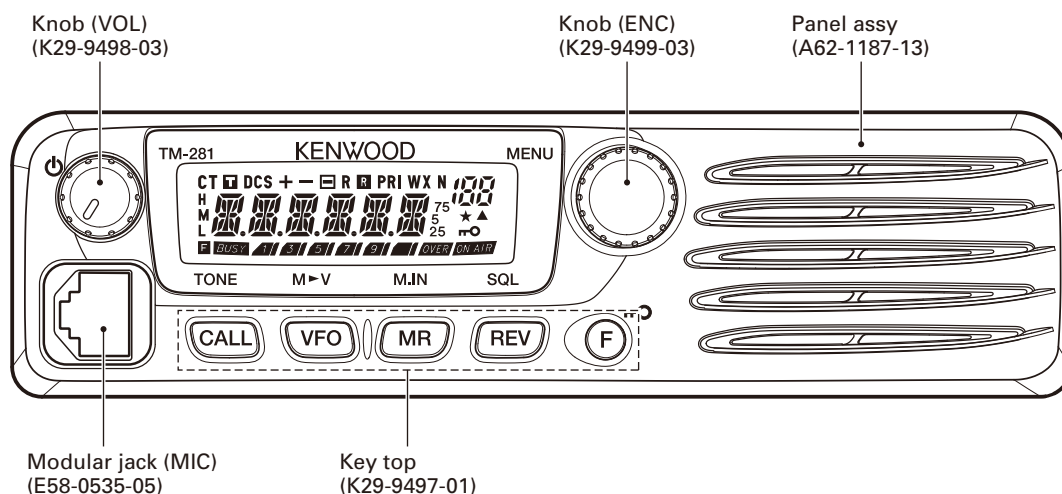

CONTENTS

DISASSEMBLY FOR REPAIR	2	TERMINAL FUNCTION	29
CIRCUIT DESCRIPTION	5	PC BOARD	
COMPONENTS DESCRIPTION.....	9	TX-RX UNIT (X57-8130-XX).....	30
SEMICONDUCTOR DATA.....	11	SCHEMATIC DIAGRAM	36
PARTS LIST	12	BLOCK DIAGRAM	40
EXPLODED VIEW	18	LEVEL DIAGRAM	42
PACKING.....	19	SPECIFICATIONS	BACK COVER
ADJUSTMENT	20		

TM-281A

Document Copyrights

Copyright 2011 by Kenwood Corporation. All rights reserved.

No part of this manual may be reproduced, translated, distributed, or transmitted in any form or by any means, electronic, mechanical, photocopying, recording, or otherwise, for any purpose without the prior written permission of Kenwood.

Disclaimer

While every precaution has been taken in the preparation of this manual, Kenwood assumes no responsibility for errors or omissions. Neither is any liability assumed for damages resulting from the use of the information contained herein. Kenwood reserves the right to make changes to any products herein at any time for improvement purposes.

DISASSEMBLY FOR REPAIR

1. Disassembly Procedure

1. When removing the cabinet, first remove the two screws from the right and left with a phillips screwdriver. Then, hook your finger on the edge of the cabinet and pull it out until it is over the chassis protrusion. Remove the cabinet by prying the cabinet as shown below.

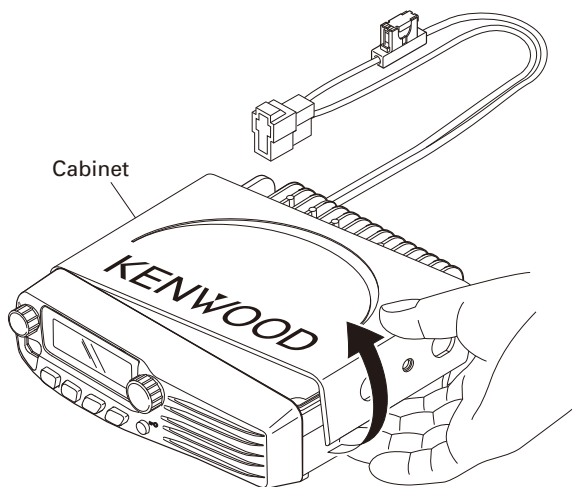

2. To remove the panel assembly, first turn the transceiver upside down. Then, insert a flat-head screwdriver into the holes of the chassis and tilt it in the direction as shown by the arrow.

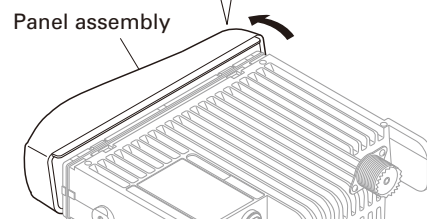
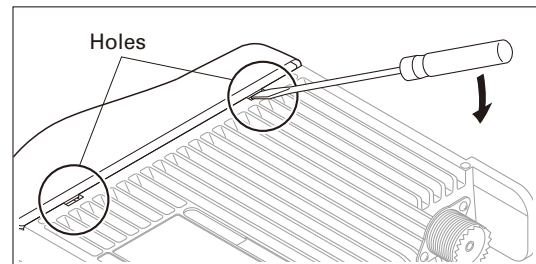

DISASSEMBLY FOR REPAIR

3. Disconnect the flat cable from the connector of the panel assembly.

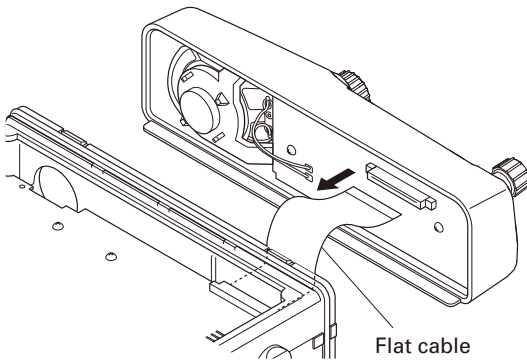

4. To remove the Display PCB, first remove the volume knob ①. Then, remove the encoder knob ②. Remove the two screws ③ from the Display PCB using a phillips screwdriver. Remove the speaker holder of the key top from the speaker. ④ Remove the Display PCB with the speaker from the panel assembly. ⑤

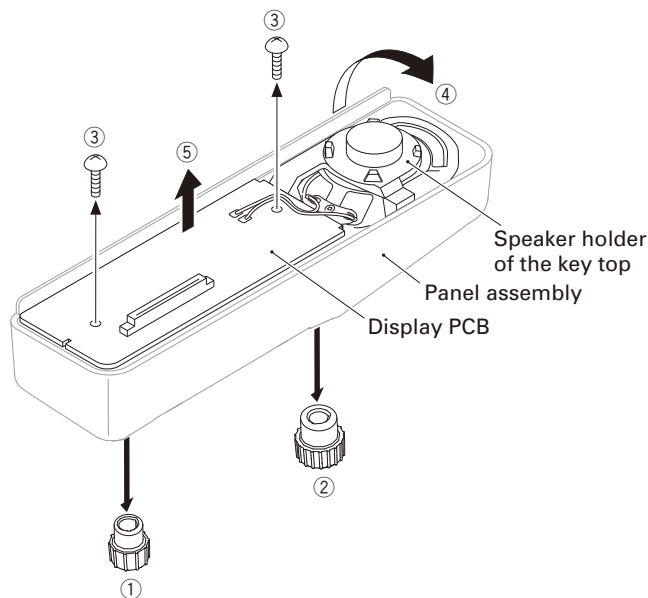

5. When removing the TX-RX PCB, first remove the solder of the antenna hot pin and positive terminal of the DC cord.

Then, remove the 15 screws from the TX-RX PCB, power module, and audio amp.

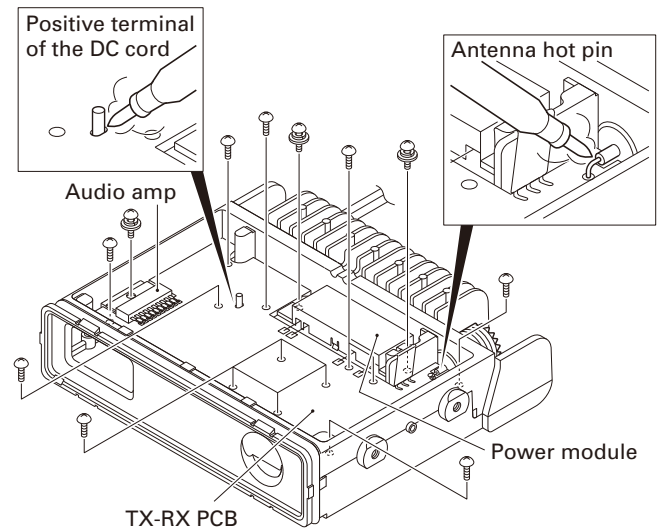

Note:

When you supply power to the TX-RX PCB after removing the TX-RX PCB from the chassis, solder the positive and ground terminals of the DC cord (recommendation: E30-3448-25) to the +B and GND terminals of the TX-RX PCB.

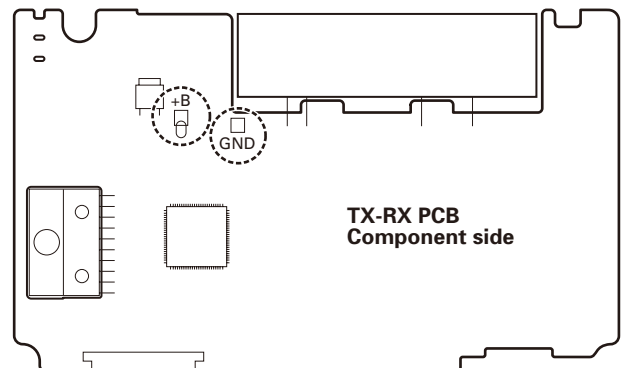

DISASSEMBLY FOR REPAIR

6. Pull it out behind the chassis by rotating the bush ③ of the DC cord 90 degrees in the direction of the arrow after the screw ① in the negative terminal is removed, and the positive terminal ② is removed from the chassis.

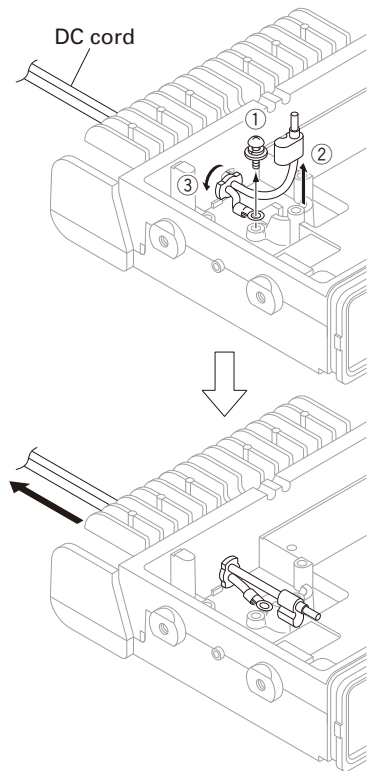

2. When mounting the panel assembly, pass the flat cable through the hole of the chassis as shown below, then connect the flat cable to connector of the panel assembly.

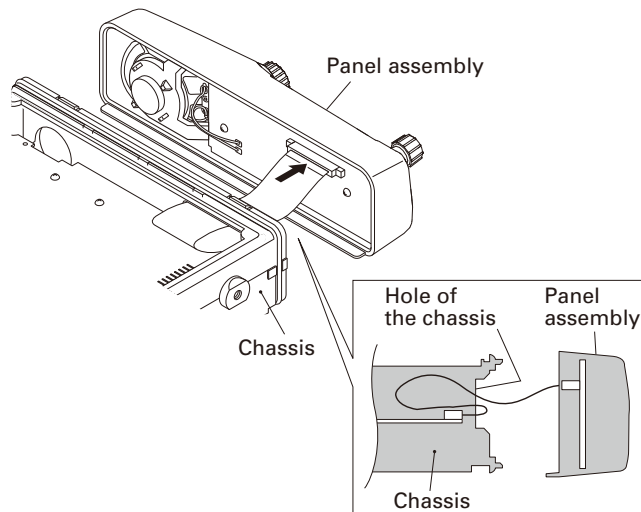

3. Fit the panel assembly into the two tabs of the chassis top side first. Then, fit the panel assembly into the two tabs of the chassis bottom side by turning the panel assembly.

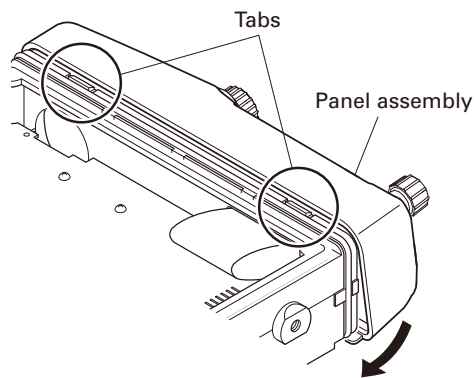

2. Precautions for Reassembly

1. Mount the key top and speaker onto the panel assembly. Then, tighten the two screws ① of the Display PCB. Insert the protrusion area of the key top into the groove area of the panel assembly using a flat-head screwdriver. ② Then, mount the encoder knob ③ and volume knob ④.

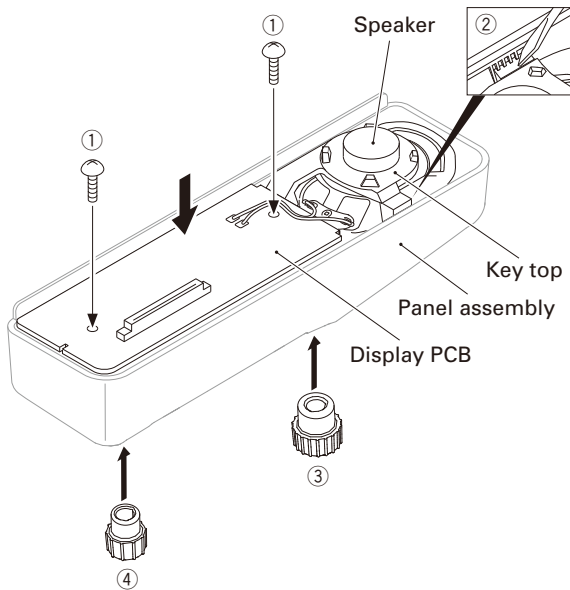

3. How to Mount the AF PA IC (IC715)

Solder it onto the TX-RX unit (A/2) so that the AF PA IC part number label "LA4600" is on the reverse side.

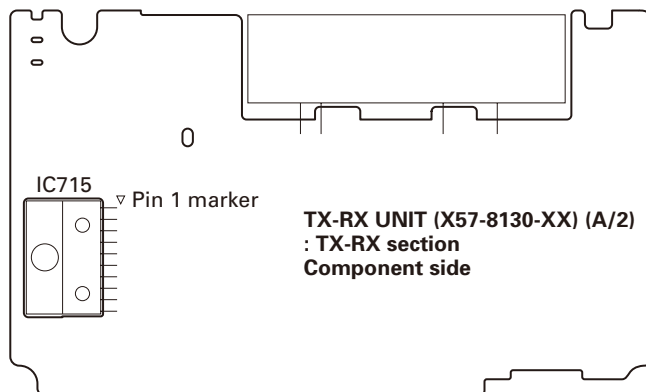

CIRCUIT DESCRIPTION

Frequency Configuration

The receiver utilizes double conversion. The first IF is 49.95MHz and the second IF is 450kHz. The first local oscillator signal is supplied from the PLL circuit.

The PLL circuit in the transmitter generates the necessary frequencies. Figure 1 shows the frequencies.

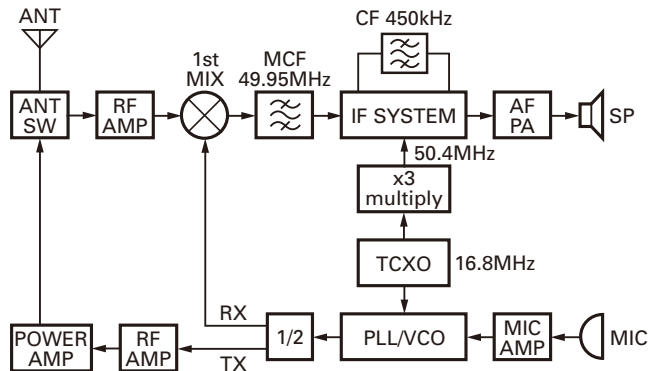

Fig. 1 Frequency configuration

Receiver System

The receiver is a double conversion superheterodyne. The frequency configuration is shown in Figure 1.

■ Front-end RF Amplifier

An incoming signal from the antenna is applied to an RF amplifier (Q505) after passing through a transmit/receive switch circuit (D309, D311, D306 and D307 are off) and a band pass filter (L515, L514 and varactor diodes: D509, D508). After the signal is amplified, the signal is filtered through a band pass filter (L511, L510 and varactor diodes: D506, D505) to eliminate unwanted signals before it is passed to the first mixer.

The voltage of these diodes are controlled by tracking the MCU (IC707) center frequency of the band pass filter. (See Fig. 2.)

■ First Mixer

The signal from the RF amplifier is heterodyned with the first local oscillator signal from the PLL frequency synthesizer circuit at the first mixer (Q504) to create a 49.95MHz first intermediate frequency (1st IF) signal. The first IF signal is then fed through the monolithic crystal filter (MCF: XF501) to further remove spurious signals.

■ IF Amplifier

The first IF signal is amplified by Q503, and then goes to IC501 (FM processing IC). The signal is heterodyned again with a second local oscillator signal within IC501 to create a 450kHz second IF signal. The second IF signal is then fed through a 450kHz ceramic filter (Wide: CF501, Narrow: CF502) to further eliminate unwanted signals before it is amplified and FM detected in IC501.

Item	Rating
Nominal center frequency	49.95MHz
Pass bandwidth	±4.0kHz or more at 3dB
50dB stop bandwidth	±25.0kHz or less
Ripple	1.0dB or less
Insertion loss	5.0dB or less
Guaranteed attenuation	80dB or more at $f_o \pm 900\text{kHz}$
Spurious	50dB or more at $f_o \pm 1\text{MHz}$
Terminating impedance	270Ω / 8.5pF

Table 1 Crystal filter (L71-0655-05): XF501

Item	Rating
Nominal center frequency	450kHz
6dB bandwidth	±7.5kHz or more
50dB bandwidth	±15.0kHz or less
Ripple	2.0dB or less
Insertion loss	6.0dB or less
Guaranteed attenuation	35.0dB or more within $f_o \pm 100\text{kHz}$
I/O matching impedance	1.5kΩ

Table 2 Ceramic filter (L72-1034-05): CF501

Item	Rating
Nominal center frequency	450kHz
6dB bandwidth	±4.5kHz or more
50dB bandwidth	±10.0kHz or less
Ripple	2.0dB or less
Insertion loss	6.0dB or less
Guaranteed attenuation	60.0dB or more within $f_o \pm 100\text{kHz}$
I/O matching impedance	2.0kΩ

Table 3 Ceramic filter (L72-0999-05): CF502

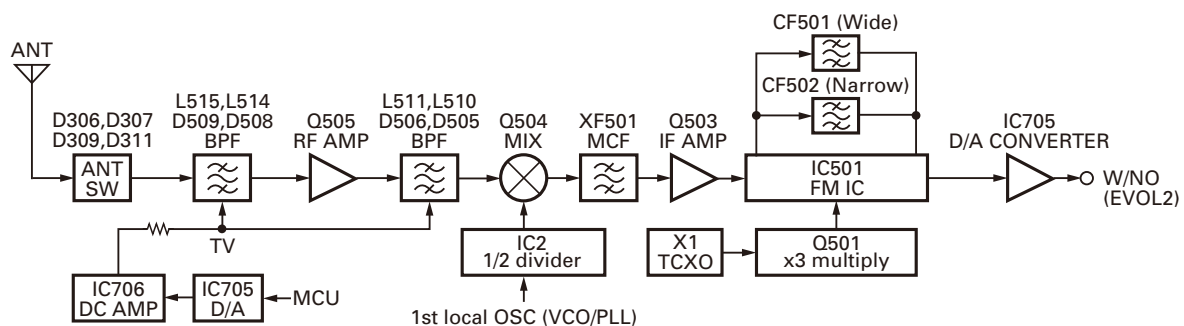

Fig. 2 Receiver system

CIRCUIT DESCRIPTION

Wide/Narrow Switching Circuit

The Wide port (pin 65) and Narrow port (pin 64) of the MCU is used to switch between ceramic filters. When the Wide port is high, the ceramic filter SW diodes (D501, D502) cause CF501 to turn on to receive a Wide signal.

When the Narrow port is high, the ceramic filter SW diodes (D501, D502) cause CF502 to turn on to receive a Narrow signal. (See Fig. 3.)

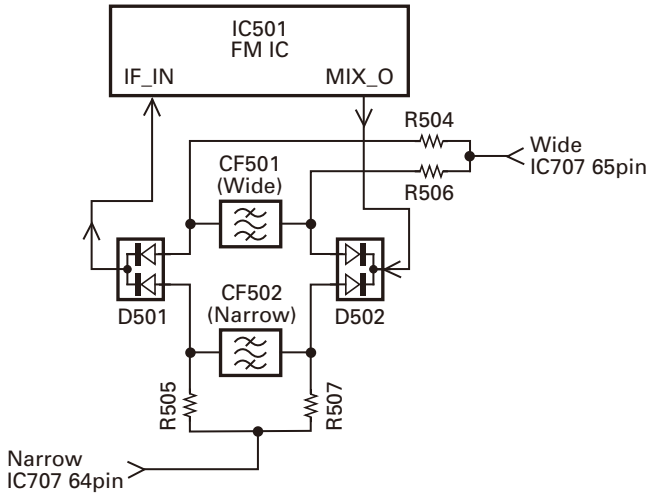

Fig. 3 Wide/Narrow switching circuit

AF Signal System

The detection signal from the FM IC (IC501) goes to the D/A converter (IC705) to adjust the gain and is output to the AF filter (IC709) for characterizing the signal. The AF signal output from IC709 and the DTMF signal, BEEP signal are summed and the resulting signal goes to the D/A converter (IC705). The AFO output level is adjusted by the D/A converter. The signal output from the D/A converter is input to the audio power amplifier (IC715). The AF signal from IC715 switches between the internal speaker and the speaker jack (J701) output. (See Fig. 4.)

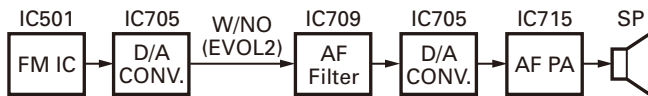

Fig. 4 AF signal system

Squelch Circuit

The detection output from the FM IC (IC501) passes through a noise amplifier (Q502) to detect noise. A voltage is applied to the MCU (IC707). The MCU controls the squelch according to the voltage (SQIN) level. The signal from the RSSI pin of IC501 is used for the S-meter. The electric field strength of the receive signal can be known before the SQIN voltage is input to the MCU, and the scan stop speed is improved.

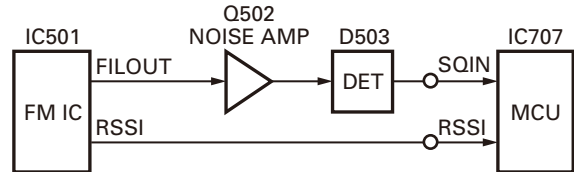

Fig. 5 Squelch circuit

PLL Frequency Synthesizer

The PLL circuit generates the first local oscillator signal for reception and the RF signal for transmission.

PLL

The frequency step of the PLL circuit is 5 or 6.25kHz. A 16.8MHz reference oscillator signal is divided at IC1 by a fixed counter to produce the 5 or 6.25kHz reference frequency. The voltage controlled oscillator (VCO) output signal is buffer amplified by Q9, then divided in IC1 by a dual-module programmable counter. The divided signal is compared in phase with the 5 or 6.25kHz reference signal in the phase comparator in IC1. The output signal from the phase comparator is filtered through a low-pass filter and passed to the VCO to control the oscillator frequency. (See Fig. 6.)

VCO

Double the operating frequency is generated by Q6 in transmit mode and Q4 in receive mode. The oscillator frequency is controlled by applying the VCO control voltage, obtained from the phase comparator, to the varactor diodes (D4 and D6 in transmit mode and D3 and D5 in receive mode). The TX/RX pin is set high in receive mode causing Q7 and Q5 to turn Q6 off, and turn Q4 on. The TX/RX pin is set low in transmit mode. The outputs from Q4 and Q6 are amplified by Q9 and sent to the RF amplifiers through a 1/2 divider (IC2). (See Fig. 6.)

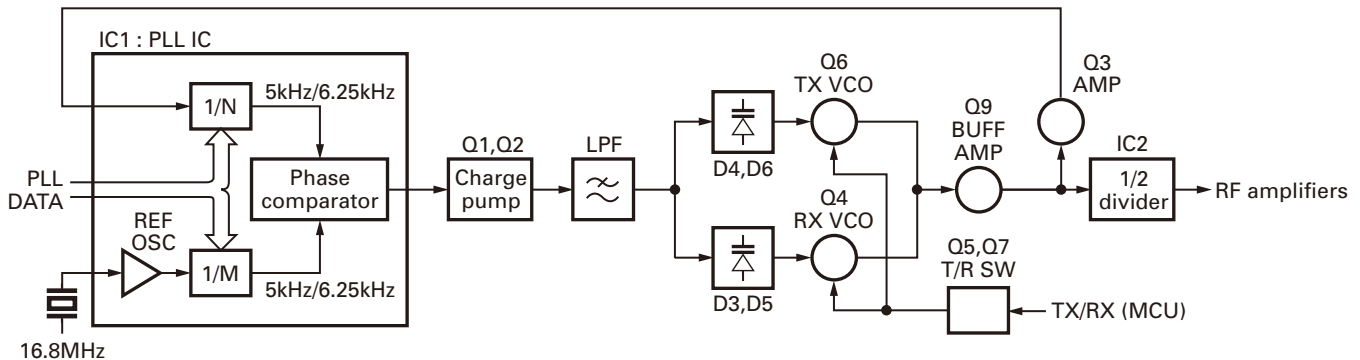

Fig. 6 PLL circuit

CIRCUIT DESCRIPTION

■ Unlock Circuit

During reception, the 8RC signal goes high, the 8TC signal goes low, and Q708 turns on. Q710 turns on and a voltage is applied to 8R. During transmission, the 8RC signal goes low, the 8TC signal goes high and Q709 turns on. Q711 turns on and a voltage is applied to 8T.

The MCU monitors the PLL IC (IC1) LD signal directly. When the PLL is unlocked during transmission, the PLL LD signal goes low. The MCU detects this signal and makes the 8TC signal low. When the 8TC signal goes low, no voltage is applied to 8T, and no signal is transmitted. (See Fig. 7.)

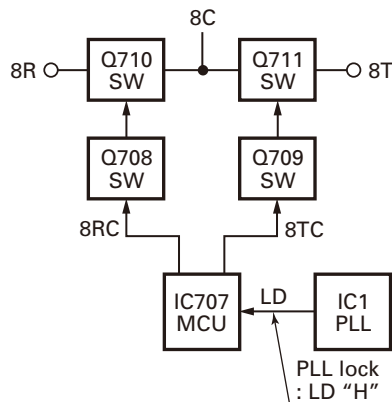

Fig. 7 Unlock circuit

Transmitter System

■ Outline

The transmitter circuit produces and amplifies the desired frequency directly. It FM-modulates the carrier signal by means of a varicap diode.

■ Power Amplifier Circuit

The transmit output signal from the VCO passes through a 1/2 divider (IC2) and the transmission/reception selection diode (D9, D10) and is amplified by Q303. The amplified signal goes to the power module (IC302) through a low-pass filter. The low-pass filter removes unwanted high-frequency harmonic components, and the resulting signal is transmitted through the antenna terminal. (See Fig. 8.)

■ APC Circuit

The automatic transmission power control (APC) circuit detects part of a final amplifier output with a diode (D313, D314) and applies a voltage to IC303. IC303 compares the APC control voltage (PC) generated by the D/A converter (IC705) and DC amplifier (IC706) with the detection output voltage. IC303 generates the voltage to control the V_{gg} of IC302 and stabilizes the transmission output.

The APC circuit is configured to protect over current of IC302 due to fluctuations of the load at the antenna end and to stabilize transmission output at voltage and temperature variations. (See Fig. 9.)

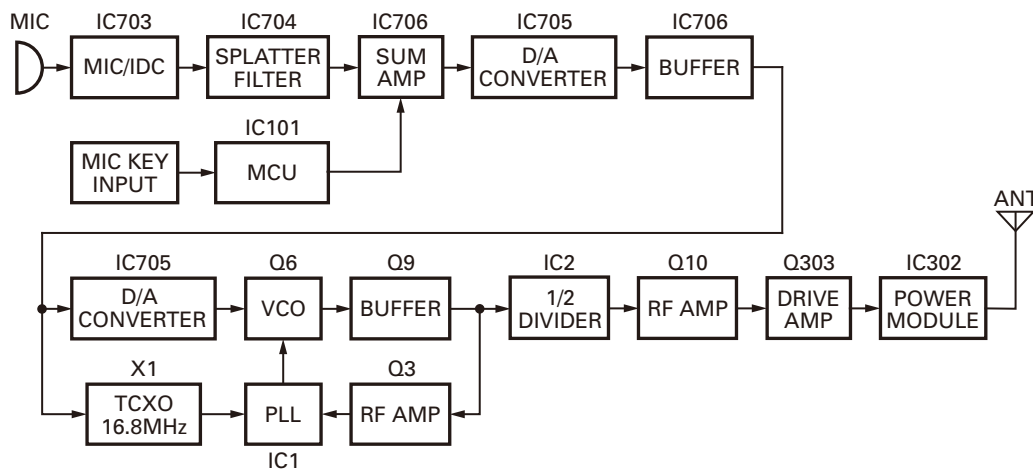

Fig. 8 Transmitter system

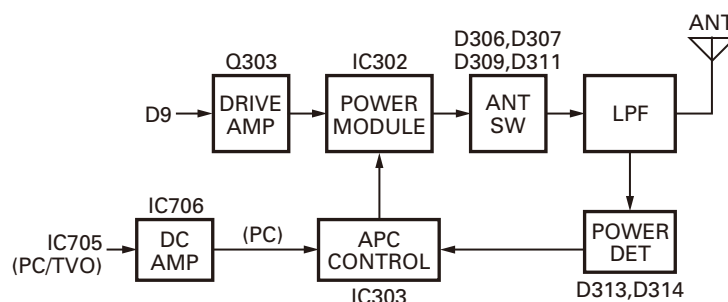

Fig. 9 APC circuit

CIRCUIT DESCRIPTION

Control Circuit

The MCU carries out the following tasks (See Fig. 10.):

- 1) Controls the WIDE, NARROW, and TX/RX outputs.
- 2) Controls the display circuit.
- 3) Controls the PLL IC (IC1).
- 4) Controls the D/A converter (IC705) and adjusts the volume, modulation and transmission power.

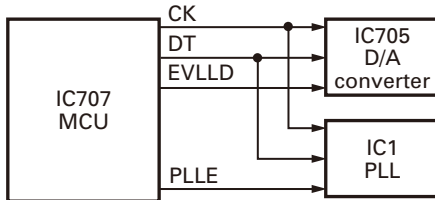

Fig. 10 Control circuit

Memory Circuit

The transceiver has an 64k-bit EEPROM (IC708). The EEPROM contains adjustment data. The MCU (IC707) controls the EEPROM through three serial data lines. (See Fig. 11.)

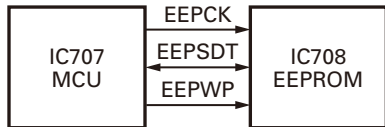

Fig. 11 Memory circuit

Display Circuit

The MCU (IC707) controls the display LCD and LEDs. When power is on, the LCD driver will use the BL line to control the LCD illumination and key backlight LEDs.

The brightness function is controlled by switch Q904. The LCD driver (IC901) and MCU (IC707) communicate through the CE, CL, DI, and DO lines. (See Fig. 12.)

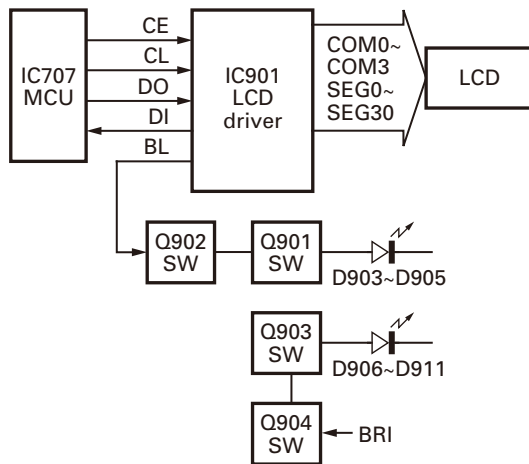

Fig. 12 Display circuit

Key Matrix Circuit

The front panel has function keys. Each of them is connected to a cross point of a matrix of the KI1 to KI3 and KS1 to KS2 ports of the LCD driver.

The LCD driver monitors the status of the KI1 to KI3 and KS1 to KS2 ports. If the state of one of the ports changes, the LCD driver assumes that the key at the matrix point corresponding to that port has been pressed.

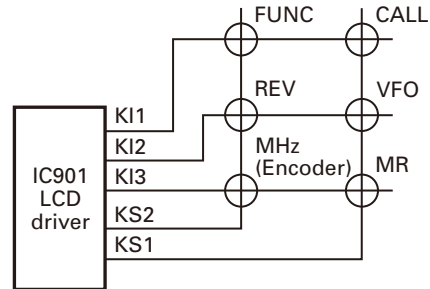

Fig. 13 Key matrix circuit

Encode

The CTCSS and DCS signals are output from TONE of the MCU (IC707). The DTMF signal is output from DTMF of the MCU (IC707). These signals are summed with a MIC signal by the summing amplifier (IC706), and the resulting signal goes to the D/A converter (IC705) to adjust the MOD level, and then goes to the buffer amplifier (IC706).

Part of the signal goes to the TCXO, and the rest goes to the D/A converter (IC705) in order to adjust the modulation balance between the VCO and TCXO.

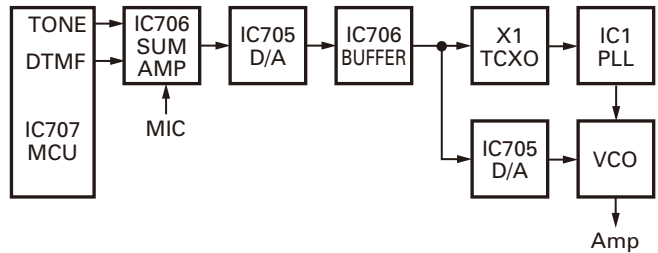

Fig. 14 Encode

Decode

• CTCSS/DCS

The signal (W/NO (EVOL2)) goes to DTMF IN (pin 95) of the MCU (IC707) through the amplifier (IC709). The CTCSS/DCS signal will pass through the low-pass filters in the MCU (IC707) and be decoded within the MCU (IC707).

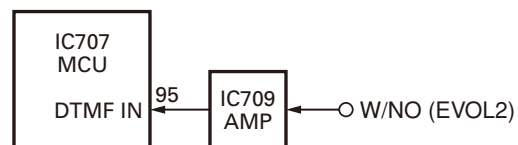

Fig. 15 Decode

CIRCUIT DESCRIPTION

■ D/A Converter

The D/A converter (IC705) is used to adjust the MO modulation, AF volume, TV voltage, FC reference voltage, and PC POWER CONTROL voltage level.

Adjustment values are sent from the MCU as serial data. The D/A converter has a resolution of 256 and the following relationship is valid:

$$\text{D/A output} = (\text{Vin} - \text{VDAref}) / 256 \times n + \text{VDAref}$$

Vin: Analog input

VDAref: D/A reference voltage (Approx. 2.2V)

n: Serial data value from the microprocessor (MCU)

Power Supply Circuit

When the power switch on the display unit is pressed, the power port on the display unit which is connected to port 17 (POWER), goes low, then port 82 (SBC) goes high, Q713 turns on, SB SW (Q714) turns on and power (SB) is supplied to the radio.

When the DC power is supplied to the radio, the voltage regulator IC (IC713) is supplied to the MCU VDD and reset voltage detect IC (IC714). IC714 will generate a signal (RESET) into the reset terminal of the MCU (IC707) to carry out a power ON reset. If DC power is less than approximately 9.5V, the radio is unable to power on.

When the DC power voltage decreases from the normal voltage, the INT voltage detector IC (IC712) will set to high

on MCU port 18 (INT) if B line becomes less than approximately 9.5V. The MCU will then send the backup data to the EEPROM (IC708) and enter stop mode.

This circuit has an overvoltage protection circuit. If a DC voltage of 18V or higher is applied to the base of Q707, this voltage turns Q707 on and will set to high on MCU port 18 (INT). The MCU will then send the backup data to the EEPROM (IC708) and enter stop mode. (See Fig. 16.)

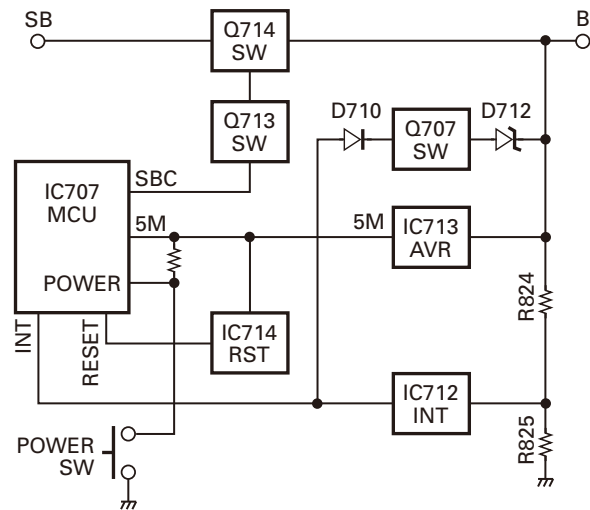

Fig. 16 Power supply circuit

COMPONENTS DESCRIPTION

TX-RX UNIT (X57-8130-XX)

Ref. No.	Use / Function	Operation / Condition / Compatibility
IC1	PLL IC	Frequency control
IC2	Divider	Frequency divider
IC302	Power module	TX final amplifier
IC303	APC controller	TX power control
IC501	FM IC	FM detector/ 2nd mixer/ RSSI/ Noise amplifier
IC703	OP amplifier	MIC amplifier/ IDC
IC704	OP amplifier	Splatter filter
IC705	Digital potentiometer	Frequency adjustment Modulation balance adjustment AF level adjustment Backlight control Modulation limit adjustment TX power/ BPF control RX signal level control

Ref. No.	Use / Function	Operation / Condition / Compatibility
IC706	OP amplifier	Buffer amplifier/ SUM amplifier/ DC amplifier/ 1/2 VCC
IC707	MCU	
IC708	EEPROM	Tuning data/ Memory data
IC709	OP amplifier	Audio filter
IC710	5V AVR	5C
IC711	8V AVR	8C
IC712	Voltage detection	MCU INT voltage detection
IC713	5V AVR	5M
IC714	Voltage detection	MCU reset voltage detection
IC715	Audio amplifier	Audio final amplifier
IC901	LCD driver	Display control
Q1,2	Switching	Charge pump
Q3	RF amplifier	PLL Fin

COMPONENTS DESCRIPTION

Ref. No.	Use / Function	Operation / Condition / Compatibility
Q4	Oscillator	RX VCO
Q5	T/R switch	On when RX
Q6	Oscillator	TX VCO
Q7	T/R switch	
Q8	Ripple filter	
Q9	Buffer amplifier	Output of VCO
Q10	RF amplifier	Output of VCO
Q303	Drive amplifier	TX driver
Q501	Tripler	16.8MHz × 3
Q502	SQL amplifier	Noise amplifier
Q503	IF amplifier	
Q504	Mixer	1st mixer
Q505	RF amplifier	LNA
Q506	PC/TV switch	On when TX
Q701	AGC/ MIC mute	
Q702,703	Beat shift switch	Active while beat shift is ON
Q704,705	AF mute	Active while AFM is "H"
Q706	Buffer amplifier	RX audio
Q707	Over voltage detection	Active when PS voltage is more than 18V
Q708	DC switch (8R)	Active while RX
Q709	DC switch (8T)	Active while TX
Q710	DC switch (8R)	Active while RX
Q711	DC switch (8T)	Active while TX
Q712	AF mute	Active while SPM is "H"
Q713,714	DC switch (SB)	Active when power is ON
Q715	AF mute	Active while AMPSW is "H"
Q901	Key backlight switch	
Q902	DC switch	
Q903	LCD backlight switch	
Q904	Brightness function switch	
D1	Voltage dropped	
D2	Ripple filter	
D3	VCO frequency control	RX
D4	VCO frequency control	TX

Ref. No.	Use / Function	Operation / Condition / Compatibility
D5	VCO frequency control	RX
D6	VCO frequency control	TX
D7	VCO modulation	
D8	Ripple filter	
D9,10	RF switch	TX/RX
D301	Voltage protection	5.1V Zener diode
D305	Protection	PC/TV
D306,307	ANT switch	On when TX
D309	ANT switch	On when TX
D311	ANT switch	On when TX
D312	Temperature compensation	
D313,314	APC voltage detect	
D316	Protection	
D501,502	IF switch	Wide/Narrow
D503	Detection	Noise squelch
D504	Protection	
D505,506	RF BPF tuning	
D508,509	RF BPF tuning	
D702	Surge absorption	CM
D704	Surge absorption	MIC key
D705	Surge absorption	RXD
D706	Surge absorption	PTT
D708	MIC mute	
D709	Detection	AGC
D710	Protection	
D711	Limiter	
D712	Over voltage detection	On when PS voltage is more than 18V
D714	Reverse connection protection	
D901	Reverse connection protection	
D902	Surge absorption	6.2V Zener diode
D903~905	LED	Key backlight
D906~911	LED	LCD backlight

SEMICONDUCTOR DATA

MCU: 30622MEP540GU (TX-RX unit IC707)

Pin No.	Name	I/O	Function
1	TONE	O	CTCSS/DCS output
2	DTMF	O	DTMF/BEEP/1750Hz output
3	PLLE	O	PLL IC chip select
4,5	NC	I	Not used
6	GND	-	GND
7	CNVSS	-	Not used
8	EVLLD	O	D/A converter chip select
9	BSHIFT	O	Beat shift
10	RESET	I	Reset
11	XOUT	O	X'tal (8MHz)
12	VSS	-	GND
13	XIN	I	X'tal (8MHz)
14	VCC	-	+5V
15	GND	-	GND
16	NC	I	Not used
17	POWER	I	Power key input
18	INT	I	MCU stop
19	NC	I	Not used
20	TX/RX	O	TX/RX
21	UL	I	PLL unlock detect
22,23	NC	I	Not used
24	EEPSDT	I/O	EEPROM data
25	EEPCK	O	EEPROM clock
26	EEPWP	O	EEPROM write protect
27,28	NC	I	(Nch open drain)
29	TXD1	O	Not used
30	RXD1	I	Not used
31	CLKFLS	I	Not used
32	BSYFLS	O	Not used
33	TXD	O	To PC
34	RXD	I	From PC
35	PTT	I	PTT input
36~38	NC	I	Not used
39	EMPFLS	I/O	Not used
40~43	NC	I	Not used
44	CEFLS	I/O	Not used
45~49	NC	I	Not used
50	AFM	O	AF mute
51	SPM	O	Speaker mute
52	AMPSW	O	AF AMP switch

Pin No.	Name	I/O	Function
53	DT	O	Common data
54	CK	O	Common clock
55	NC	I	Not used
56	DST1	I	Destination 1
57~59	DST2~DST4	I	Destination 2~4
60	VCC	-	+5V
61	NC	I	Not used
62	VSS	-	GND
63	ADJ	I	For adjustment mode
64	NARROW	O	Narrow
65	WIDE	O	Wide
66,67	NC	I	Not used
68	CL	O	Clock for LCD
69	CE	O	Chip enable for LCD
70	DO	O	Output data to LCD
71	DI	I	Input data from LCD
72	NC	I	Not used
73	ENCB	I	Encoder input B
74	ENCA	I	Encoder input A
75,76	NC	O	Not used
77	MICMT	O	MIC mute
78	NC	I	Not used
79	8RC	O	8R control
80	8TC	O	8T control
81	NC	I	Not used
82	SBC	O	Battery switch
83~85	NC	I	Not used
86	CM	I	MIC key check
87	MICKEY2	I	For AMR DTMF keypad MIC
88	MICKEY	I	For AMR DTMF keypad MIC
89	VOL	I	Volume encoder
90	TEMP2	I	Temperature 2
91	TEMP1	I	Temperature 1
92	RSSI	I	RSSI input
93	SQIN	I	Squelch input
94	AVSS	-	GND
95	DTMF IN	I	CTCSS/DCS/1050Hz input
96	VREF	-	+5V
97	AVCC	-	+5V
98~100	NC	I	Not used

TM-281A

PARTS LIST

* New Parts. Δ indicates safety critical components.

Parts without **Parts No.** are not supplied.

Les articles non mentionnés dans le **Parts No.** ne sont pas fournis.

Teile ohne **Parts No.** werden nicht geliefert.

L : Scandinavia

K : USA

P : Canada

Y : PX (Far East, Hawaii)

T : England

E : Europe

C : China

X : Australia

M : Other Areas

TM-281A

TX-RX UNIT (X57-8130-XX)

Ref. No.	Address	New parts	Parts No.	Description	Destination	Ref. No.	Address	New parts	Parts No.	Description	Destination	
TM-281A						C16			CK73HB1H102K	CHIP C	1000PF	K
1	1B	*	A02-4156-01	PLASTIC CABINET		C17			CK73HB1H103K	CHIP C	0.010UF	K
2	2B	*	A10-4152-01	CHASSIS		C18			CK73HB1E104K	CHIP C	0.10UF	K
3	3A	*	A62-1187-13	PANEL ASSY		C20,21			CK73HB1H471K	CHIP C	470PF	K
						C23			CK73HB1H471K	CHIP C	470PF	K
5	3A		B11-1809-03	ILLUMINATION GUIDE (LCD)		C25			C92-0863-05	CHIP TNTL	0.047UF	35WV
6	3A		B38-0885-15	LCD		C27			C92-0588-05	CHIP TNTL	1.5UF	16WV
7	3C	*	B62-2347-10	INSTRUCTION MANUAL	K,M2	C28			CK73HB1H471K	CHIP C	470PF	K
7	3C	*	B62-2348-10	INSTRUCTION MANUAL	M3	C29			CS77CA1V0R1M	CHIP TNTL	0.1UF	35WV
7	3C	*	B62-2349-10	INSTRUCTION MANUAL	M4	C34			CK73HB1H102K	CHIP C	1000PF	K
10	2B		E04-0167-15	RF COAXIAL RECEPTACLE (M)		C35			CC73HCH1H820J	CHIP C	82PF	J
11	2B		E23-1346-04	GROUND TERMINAL (CLIP)		C36			CC73HCH1H300J	CHIP C	30PF	J
12	3A		E29-1201-04	INTER CONNECTOR (LCD)		C38			CC73HCH1H100C	CHIP C	10PF	C
13	2B	*	E30-7743-05	DC CORD		C39			CC73HCH1H080B	CHIP C	8.0PF	B
14	1C	*	E30-7744-05	DC CORD ACCESSORY		C41			CC73HCH1H0R5B	CHIP C	0.5PF	B
15	2A	*	E37-1542-05	FLAT CABLE		C42,43			CK73HB1H471K	CHIP C	470PF	K
16	3A	*	E37-1545-05	PARALLEL CORD (SP)		C45			CC73HCH1H010B	CHIP C	1.0PF	B
						C46			CC73HCH1H0R5B	CHIP C	0.5PF	B
18	1C		F52-0024-05	FUSE (BLADE TYPE) 15A ACCESSORY		C48			CK73HB1H102K	CHIP C	1000PF	K
19	3A	*	G13-2370-04	CUSHION (LCD)		C49			CC73HCH1H4R5B	CHIP C	4.5PF	B
20	3A	*	G53-1878-03	PACKING (PANEL)		C50			CC73HCH1H100C	CHIP C	10PF	C
						C51			CC73HCH1H050B	CHIP C	5.0PF	B
22	1D	*	H12-4330-02	PACKING FIXTURE (RADIO)		C52			CC73HCH1H110G	CHIP C	11PF	G
23	2D	*	H12-4331-02	PACKING FIXTURE		C53			CK73HB1H102K	CHIP C	1000PF	K
24	2D	*	H52-2503-02	ITEM CARTON CASE	K	C54			CC73HCH1H0R3B	CHIP C	0.3PF	B
26	1C		J19-1584-15	HOLDER (MIC) ACCESSORY		C55			CC73HCH1H0R5B	CHIP C	0.5PF	B
27	3A		J21-9463-03	MOUNTING HARDWARE (LCD)		C56			CS77BB21C220M	CHIP TNTL	22UF	16WV
28	2C		J29-0726-03	BRACKET ACCESSORY		C57			CK73HB1H471K	CHIP C	470PF	K
30	3A	*	K29-9497-01	KEY TOP		C58			CK73HB1H102K	CHIP C	1000PF	K
31	3A	*	K29-9498-03	KNOB (VOL)		C59			CK73HB1H471K	CHIP C	470PF	K
32	3A	*	K29-9499-03	KNOB (ENC)		C60			CC73HCH1H060B	CHIP C	6.0PF	B
A	1A,1B		N35-2604-43	BINDING HEAD MACHINE SCREW		C61			CC73HCH1H030B	CHIP C	3.0PF	B
B	1A,1B,2B		N67-3008-48	PAN HEAD SEMS SCREW		C62			CC73HCH1H020B	CHIP C	2.0PF	B
C	3A		N80-2008-48	PAN HEAD TAPTITE SCREW		C63			CK73HB1H102K	CHIP C	1000PF	K
D	1B,2B		N87-2608-48	BRAZIER HEAD TAPTITE SCREW		C64			CC73HCH1H221J	CHIP C	220PF	J
34	2C	*	N99-2082-05	SCREW SET ACCESSORY		C65,66			CK73HB1H102K	CHIP C	1000PF	K
36	3A		T07-0779-05	SPEAKER		C67			CC73HCH1H180J	CHIP C	18PF	J
37	1C		T91-0624-65	MICROPHONE ACCESSORY	M2	C68-70			CK73HB1H102K	CHIP C	1000PF	K
37	1C	*	T91-0641-75	MICROPHONE (DTMF) ACCESSORY	K,M3,M4	C71			CC73HCH1H390J	CHIP C	39PF	J
						C72			CC73HCH1H180J	CHIP C	18PF	J
						C306			CK73HB1H102K	CHIP C	1000PF	K
						C308			CK73HB1H122K	CHIP C	1200PF	K
						C309			CC73HCH1H060B	CHIP C	6.0PF	B
						C310			CC73HCH1H080B	CHIP C	8.0PF	B
						C312			CC73HCH1H120J	CHIP C	12PF	J
TX-RX UNIT (X57-8130-XX) -10: K -21: M2 -22: M3 -23: M4						C318			CK73HB1H102K	CHIP C	1000PF	K
D903-911			B30-2337-05	LED (YELLOW)		C328			CC73HCH1H130J	CHIP C	13PF	J
C1			CK73FB0J226M	CHIP C	22UF	M			CK73HB1H102K	CHIP C	1000PF	K
C3,4			CC73HCH1H101J	CHIP C	100PF	J			CC73HCH1H2R5B	CHIP C	2.5PF	B
C5,6			CK73HB1H102K	CHIP C	1000PF	K			CK73HB1E223K	CHIP C	0.022UF	K
C7			CC73HCH1H101J	CHIP C	100PF	J						
C9			CK73HB1E104K	CHIP C	0.10UF	K						
C10			CC73HCH1H680J	CHIP C	68PF	J			CC73HCH1H151J	CHIP C	150PF	J
C11			CK73HB1E104K	CHIP C	0.10UF	K			CK73FB1A475K	CHIP C	4.7UF	K
C12			CK73FB1A106K	CHIP C	10UF	K			CK73HB1H102K	CHIP C	1000PF	K
C14			CK73HB1E104K	CHIP C	0.10UF	K			CK73HB1H102K	CHIP C	1000PF	K
C15			CK73FB1A106K	CHIP C	10UF	K			CC73HCH1H221J	CHIP C	220PF	J

PARTS LIST

TX-RX UNIT (X57-8130-XX)

Ref. No.	Address	New parts	Parts No.	Description	Destination	Ref. No.	Address	New parts	Parts No.	Description	Destination
C342			CC73HCH1H101J	CHIP C 100PF J		C538			CK73HB1H103K	CHIP C 0.010UF K	
C343			CK73HB1H102K	CHIP C 1000PF K		C539			CC73HCH1H020B	CHIP C 2.0PF B	
C344,345			CC73HCH1H101J	CHIP C 100PF J		C541			CK73HB1H102K	CHIP C 1000PF K	
C347			CK73HB1E104K	CHIP C 0.10UF K		C544			CK73HB1E104K	CHIP C 0.10UF K	
C348			CK73HB1H102K	CHIP C 1000PF K		C545			CC73HCH1H130J	CHIP C 13PF J	
C350			CK73HB1H102K	CHIP C 1000PF K		C546			CC73HCH1H270J	CHIP C 27PF J	
C354			CC73HCH1H220J	CHIP C 22PF J		C547			CK73HB1H102K	CHIP C 1000PF K	
C355			CC73HCH1H470J	CHIP C 47PF J		C548			CK73HB1H103K	CHIP C 0.010UF K	
C356			CC73HCH1H220J	CHIP C 22PF J		C549,550			CK73HB1H102K	CHIP C 1000PF K	
C365			C93-0556-05	CHIP C 6.0PF D		C551			CC73HCH1H101J	CHIP C 100PF J	
C394			CK73HB1E104K	CHIP C 0.10UF K		C552			CK73HB1H102K	CHIP C 1000PF K	
C395			CK73HB1H102K	CHIP C 1000PF K		C553			CC73HCH1H030B	CHIP C 3.0PF B	
C397			CK73HB1H102K	CHIP C 1000PF K		C554			CC73HCH1H240J	CHIP C 24PF J	
C399			CK73HB1H103K	CHIP C 0.010UF K		C555			CC73HCH1H010B	CHIP C 1.0PF B	
C400,401			CK73HB1H102K	CHIP C 1000PF K		C556			CK73HB1H102K	CHIP C 1000PF K	
C402			CK73HB1H103K	CHIP C 0.010UF K		C557			CC73HCH1H050B	CHIP C 5.0PF B	
C403			CC73GCH1H270J	CHIP C 27PF J		C558			CC73HCH1H330J	CHIP C 33PF J	
C404			C93-0563-05	CHIP C 18PF J		C559-562			CK73HB1H102K	CHIP C 1000PF K	
C405,406			C93-0603-05	CHIP C 1000PF K		C565-567			CK73HB1H102K	CHIP C 1000PF K	
C407			CK73HB1H102K	CHIP C 1000PF K		C568			CC73HCH1H101J	CHIP C 100PF J	
C408			CC73GCH1H0R5B	CHIP C 0.5PF B		C569			CK73HB1H102K	CHIP C 1000PF K	
C409			CC73GCH1H040B	CHIP C 4.0PF B		C570			CC73HCH1H010B	CHIP C 1.0PF B	
C410			C93-0563-05	CHIP C 18PF J		C571			CC73HCH1H180J	CHIP C 18PF J	
C412			CK73HB1H102K	CHIP C 1000PF K		C572			CK73HB1H102K	CHIP C 1000PF K	
C413			C93-0552-05	CHIP C 2.0PF C		C573			CC73HCH1H040B	CHIP C 4.0PF B	
C415			C93-0564-05	CHIP C 22PF J		C574			CC73HCH1H1R5B	CHIP C 1.5PF B	
C416			CK73HB1H102K	CHIP C 1000PF K		C575			CK73HB1H102K	CHIP C 1000PF K	
C417			CC73GCH1H0R5B	CHIP C 0.5PF B		C576			CC73HCH1H180J	CHIP C 18PF J	
C418			CC73GCH1H040B	CHIP C 4.0PF B		C577			CK73HB1H102K	CHIP C 1000PF K	
C420			C93-0554-05	CHIP C 4.0PF C		C578			CC73HCH1H390J	CHIP C 39PF J	
C421			C93-0563-05	CHIP C 18PF J		C579			CK73HB1H102K	CHIP C 1000PF K	
C422			CK73HB1H102K	CHIP C 1000PF K		C581			CC73HCH1H330J	CHIP C 33PF J	
C502			CK73HB1H103K	CHIP C 0.010UF K		C582			CC73HCH1H010B	CHIP C 1.0PF B	
C503			CC73HCH1H271J	CHIP C 270PF J		C583			CC73HCH1H040B	CHIP C 4.0PF B	
C504			CC73HCH1H560J	CHIP C 56PF J		C584-587			CK73HB1E104K	CHIP C 0.10UF K	
C505			CC73HCH1H680J	CHIP C 68PF J		C702,703			CK73HB1A473K	CHIP C 0.047UF K	
C506			CC73HCH1H470J	CHIP C 47PF J		C713			CK73HB1H102K	CHIP C 1000PF K	
C507			CK73HB1H103K	CHIP C 0.010UF K		C718-720			CK73HB1H102K	CHIP C 1000PF K	
C508,509			CK73HB1A105K	CHIP C 1.0UF K		C722			CK73HB1H102K	CHIP C 1000PF K	
C510			CK73HB1H103K	CHIP C 0.010UF K		C724			CK73FB1A106K	CHIP C 10UF K	
C511			CK73FB1A106K	CHIP C 10UF K		C725			CK73HB1E104K	CHIP C 0.10UF K	
C513			CC73HCH1H331J	CHIP C 330PF J		C726			CK73HB1A393K	CHIP C 0.039UF K	K,M2,M3
C514,515			CK73HB1E104K	CHIP C 0.10UF K		C726			CK73HB1A683K	CHIP C 0.068UF K	M4
C516			CC73HCH1H331J	CHIP C 330PF J		C727			CK73HB1H102K	CHIP C 1000PF K	
C517			CK73HB1E104K	CHIP C 0.10UF K		C728			CK73GB0J225K	CHIP C 2.2UF K	
C518			CC73HCH1H101J	CHIP C 100PF J		C729			CK73FB1A106K	CHIP C 10UF K	
C519			CK73FB1A106K	CHIP C 10UF K		C731			CK73HB1H103K	CHIP C 0.010UF K	
C520			CK73HB1H102K	CHIP C 1000PF K		C732			CK73HB1H102K	CHIP C 1000PF K	K,M2,M3
C521			CK73HB1H103K	CHIP C 0.010UF K		C732			CK73HB1H681K	CHIP C 680PF K	M4
C522			CC73HCH1H270J	CHIP C 27PF J		C733			CK73HB1E104K	CHIP C 0.10UF K	
C523			CK73HB1E562K	CHIP C 5600PF K		C734			CK73HB1A393K	CHIP C 0.039UF K	M4
C524			CK73HB1E104K	CHIP C 0.10UF K		C734			CK73HB1C223K	CHIP C 0.022UF K	K,M2,M3
C525			CK73HB1A224K	CHIP C 0.22UF K		C735			CC73HCH1H680J	CHIP C 68PF J	
C527			CC73HCH1H050B	CHIP C 5.0PF B		C736			CK73FB1A106K	CHIP C 10UF K	
C528			CK73HB1H103K	CHIP C 0.010UF K		C737			CK73HB1H102K	CHIP C 1000PF K	
C530			CK73HB1E223K	CHIP C 0.022UF K		C738			CK73HB1E104K	CHIP C 0.10UF K	
C533			CC73HCH1H060B	CHIP C 6.0PF B		C739			CK73HB1H102K	CHIP C 1000PF K	
C534			CK73HB1A393K	CHIP C 0.039UF K		C740			CK73HB1E104K	CHIP C 0.10UF K	
C535			CK73HB1H102K	CHIP C 1000PF K		C742			CK73HB1H821K	CHIP C 820PF K	
C537			CC73HCH1H200J	CHIP C 20PF J		C743			CK73HB1H102K	CHIP C 1000PF K	

PARTS LIST

TX-RX UNIT (X57-8130-XX)

Ref. No.	Address	New parts	Parts No.	Description	Destination	Ref. No.	Address	New parts	Parts No.	Description	Destination
C744			CK73FB1A106K	CHIP C 10UF K		C828			CK73HB1H102K	CHIP C 1000PF K	
C745			CC73HCH1H390J	CHIP C 39PF J		C829			CK73HB1H103K	CHIP C 0.010UF K	
C746			CK73HB1E104K	CHIP C 0.10UF K		C830			CK73HB1H102K	CHIP C 1000PF K	
C747			CK73FB1A106K	CHIP C 10UF K		C831			CE32CL1C470M	ELECTRO 47UF 16WV	
C748			CK73HB1H102K	CHIP C 1000PF K		C832			CK73HB1E104K	CHIP C 0.10UF K	
C749			CK73HB1H103K	CHIP C 0.010UF K		C833-835			CK73HB1H102K	CHIP C 1000PF K	
C750			CC73HCH1H151J	CHIP C 150PF J		C836			C90-4129-05	ELECTRO 330UF 25WV	
C751			CK73GB1A105K	CHIP C 1.0UF K		C837			CK73HB1H103K	CHIP C 0.010UF K	
C752			CK73HB1H392K	CHIP C 3900PF K		C838			CK73HB1H102K	CHIP C 1000PF K	
C753			CK73HB1E472K	CHIP C 4700PF K		C839			C90-4129-05	ELECTRO 330UF 25WV	
C754			CK73FB1A106K	CHIP C 10UF K		C840			CK73HB1E104K	CHIP C 0.10UF K	
C757,758			CK73FB1A106K	CHIP C 10UF K		C844			CK73HB1H102K	CHIP C 1000PF K	
C761			CK73HB1E104K	CHIP C 0.10UF K		C847			CK73HB1H102K	CHIP C 1000PF K	
C763			CC73HCH1H030B	CHIP C 3.0PF B		C848-851			CK73FB1A106K	CHIP C 10UF K	
C764			CC73HCH1H050B	CHIP C 5.0PF B		C853,854			CK73FB0J226M	CHIP C 22UF M	
C765			CK73HB1H102K	CHIP C 1000PF K		C901-903			CK73HB1A104K	CHIP C 0.10UF K	
C766			CC73HCH1H050B	CHIP C 5.0PF B		C910			CK73HB1H102K	CHIP C 1000PF K	
C767			CC73HCH1H030B	CHIP C 3.0PF B		C912			CK73HB1H102K	CHIP C 1000PF K	
C768			CK73HB1E104K	CHIP C 0.10UF K		C915			CC73HCH1H101J	CHIP C 100PF J	
C769			CK73HB1H102K	CHIP C 1000PF K		C916-918			CK73HB1H102K	CHIP C 1000PF K	
C771			CK73HB1H102K	CHIP C 1000PF K		C920			CK73HB1H471K	CHIP C 470PF K	
C772			CK73HB1E104K	CHIP C 0.10UF K		C921			CK73GB1A105K	CHIP C 1.0UF K	
C774			CK73HB1H182K	CHIP C 1800PF K		C922			CK73HB1H102K	CHIP C 1000PF K	
C775			CK73HB1H392K	CHIP C 3900PF K		C924			CK73HB1A104K	CHIP C 0.10UF K	
C776			CK73HB1H102K	CHIP C 1000PF K		C926,927			CC73HCH1H101J	CHIP C 100PF J	
C777			CK73HB1A474K	CHIP C 0.47UF K		C928			CK73HB1H681K	CHIP C 680PF K	
C778			CK73GB1A105K	CHIP C 1.0UF K		C929			CK73HB1H102K	CHIP C 1000PF K	
C779			CK73HB1E104K	CHIP C 0.10UF K		TC1			C05-0245-05	CERAMIC TRIMMER CAPACITOR (10PF)	
C781			CK73HB1H102K	CHIP C 1000PF K		TC2			C05-0399-05	CERAMIC TRIMMER CAPACITOR (6PF)	
C782			CK73HB1E104K	CHIP C 0.10UF K		CN501			E23-1325-05	TERMINAL	
C783			CK73GB1A105K	CHIP C 1.0UF K		CN702		*	E40-6898-05	FLAT CABLE CONNECTOR (22P)	
C784,785			CK73HB1H103K	CHIP C 0.010UF K		CN901		*	E40-6897-05	FLAT CABLE CONNECTOR (22P)	
C786			CK73HB1A393K	CHIP C 0.039UF K		J701	2B		E11-0425-05	3.5D PHONE JACK (EXT SP)	
C787			CK73HB1E103K	CHIP C 0.010UF K		J901			E58-0535-05	MODULAR JACK (MIC)	
C788			CK73HB1H103K	CHIP C 0.010UF K		F701			F53-0327-15	FUSE (4A)	
C789,790			CK73HB1C333K	CHIP C 0.033UF K		CD501			L79-1914-05	TUNING COIL	
C793			CK73HB1C183K	CHIP C 0.018UF K		CF501			L72-1034-05	CERAMIC FILTER (450KHZ/WIDE)	
C794			CK73HB1C822K	CHIP C 8200PF K		CF502			L72-0999-05	CERAMIC FILTER (450KHZ/NARROW)	
C795			CK73HB1A224K	CHIP C 0.22UF K		L1		*	L92-0622-15	CHIP FERRITE	
C796			CK73HB1H122K	CHIP C 1200PF K		L2			L41-1005-08	SMALL FIXED INDUCTOR (10UH)	
C797			CC73HCH1H390J	CHIP C 39PF J		L3		*	L92-0621-15	CHIP FERRITE	
C798			CK73HB1A224K	CHIP C 0.22UF K		L5		*	L92-0620-15	CHIP FERRITE	
C799			CK73GB0J475K	CHIP C 4.7UF K		L6-9			L40-2785-92	SMALL FIXED INDUCTOR (270NH)	
C800,801			CK73HB1H102K	CHIP C 1000PF K		L10		*	L92-0622-15	CHIP FERRITE	
C802			CK73FB1A106K	CHIP C 10UF K		L11			L41-4778-14	SMALL FIXED INDUCTOR (47NH)	
C804			CK73HB1H103K	CHIP C 0.010UF K		L12			L41-3378-14	SMALL FIXED INDUCTOR (33NH)	
C805			CK73HB1H102K	CHIP C 1000PF K		L13-16			L40-2702-86	SMALL FIXED INDUCTOR (27UH)	
C806,807			CK73FB1A106K	CHIP C 10UF K		L17		*	L92-0622-15	CHIP FERRITE	
C808,809			CK73GB1A105K	CHIP C 1.0UF K		L18			L40-3375-71	SMALL FIXED INDUCTOR (33NH)	
C810,811			CK73HB1E104K	CHIP C 0.10UF K		L19		*	L92-0622-15	CHIP FERRITE	
C814			CK73FB1A106K	CHIP C 10UF K		L20			L40-1085-71	SMALL FIXED INDUCTOR (100NH)	
C815			CK73HB1E104K	CHIP C 0.10UF K		L21			L40-3975-71	SMALL FIXED INDUCTOR (39NH)	
C816			CK73HB1A224K	CHIP C 0.22UF K		L302			L40-2275-71	SMALL FIXED INDUCTOR (22NH)	
C817			CK73HB1H102K	CHIP C 1000PF K		L305			L40-1075-71	SMALL FIXED INDUCTOR (10NH)	
C818			CK73FB0J226M	CHIP C 22UF M		L308			L40-8265-92	SMALL FIXED INDUCTOR (8.2NH)	
C820-823			CK73HB1H102K	CHIP C 1000PF K		L309			L40-1285-92	SMALL FIXED INDUCTOR (120NH)	
C824			CK73HB1E104K	CHIP C 0.10UF K		L310			L40-4775-92	SMALL FIXED INDUCTOR (47NH)	
C825			CK73FB0J226M	CHIP C 22UF M		L312-314			L92-0179-05	CHIP FERRITE	
C826			CK73HB1H102K	CHIP C 1000PF K		L315,316			L34-4902-05	AIR-CORE COIL (9.5T)	
C827			CK73FB1E475K	CHIP C 4.7UF K							

PARTS LIST

TX-RX UNIT (X57-8130-XX)

Ref. No.	Address	New parts	Parts No.	Description	Desti- nation	Ref. No.	Address	New parts	Parts No.	Description	Desti- nation
L317			L34-1039-05	AIR-CORE COIL (1.5T)		R336			RK73HB1J470J	CHIP R 47 J 1/16W	
L318-320			L34-4903-05	AIR-CORE COIL (5T)		R337			RK73HB1J101J	CHIP R 100 J 1/16W	
L502-504			L40-3381-86	SMALL FIXED INDUCTOR (0.33UH)		R338			RK73HB1J154J	CHIP R 150K J 1/16W	
L505			L40-3391-86	SMALL FIXED INDUCTOR (3.3UH)		R339			RK73HB1J103J	CHIP R 10K J 1/16W	
L506,507			L41-3998-14	SMALL FIXED INDUCTOR (390NH)		R340			RK73HB1J223J	CHIP R 22K J 1/16W	
L508			L40-4775-71	SMALL FIXED INDUCTOR (47NH)		R341			RK73HB1J154J	CHIP R 150K J 1/16W	
L510,511			L41-6878-14	SMALL FIXED INDUCTOR (68NH)		R342			RK73HB1J152J	CHIP R 1.5K J 1/16W	
L512			L41-3385-14	SMALL FIXED INDUCTOR (330NH)		R344,345			RK73HB1J104J	CHIP R 100K J 1/16W	
L514,515			L41-6878-14	SMALL FIXED INDUCTOR (68NH)		R346			RK73EB2E221J	CHIP R 220 J 1/4W	
L701,702		*	L92-0622-15	CHIP FERRITE		R347			RK73HB1J152J	CHIP R 1.5K J 1/16W	
L901		*	L92-0621-15	CHIP FERRITE		R348			RK73HB1J153J	CHIP R 15K J 1/16W	
X1			L77-1944-05	TCXO (16.8MHZ)		R349			RK73EB2E221J	CHIP R 220 J 1/4W	
X701		*	L78-1427-05	RESONATOR (8.00MHZ)		R350			RK73HB1J100J	CHIP R 10 J 1/16W	
XF501			L71-0655-05	MCF (49.95MHZ)		R351			RK73HB1J473J	CHIP R 47K J 1/16W	
CP901			RK75GB1J102J	CHIP-COM 1.0K J 1/16W		R377,378			RK73HB1J103J	CHIP R 10K J 1/16W	
R1			RK73HB1J104J	CHIP R 100K J 1/16W		R380	2B		R92-1061-05	JUMPER REST 0 OHM	
R2-4			RK73HB1J102J	CHIP R 1.0K J 1/16W		R501			RK73HB1J124J	CHIP R 120K J 1/16W	
R5			RK73HB1J103J	CHIP R 10K J 1/16W		R502			RK73HB1J101J	CHIP R 100 J 1/16W	
R6			RK73HB1J152J	CHIP R 1.5K J 1/16W		R503			RK73HB1J682J	CHIP R 6.8K J 1/16W	
R7			RK73HB1J100J	CHIP R 10 J 1/16W		R504-507			RK73HB1J103J	CHIP R 10K J 1/16W	
R8			RK73HB1J104J	CHIP R 100K J 1/16W		R508			RK73HB1J682J	CHIP R 6.8K J 1/16W	
R9			RK73HB1J471J	CHIP R 470 J 1/16W		R509			RK73HB1J000J	CHIP R 0.0 J 1/16W	
R10			RK73HB1J822J	CHIP R 8.2K J 1/16W		R510			RK73HB1J102J	CHIP R 1.0K J 1/16W	
R11			RK73HB1J103J	CHIP R 10K J 1/16W		R511			RK73HB1J223J	CHIP R 22K J 1/16W	
R12			RK73HB1J562J	CHIP R 5.6K J 1/16W		R512			RK73HB1J564J	CHIP R 560K J 1/16W	
R13			RK73HB1J103J	CHIP R 10K J 1/16W		R514,515			RK73HB1J472J	CHIP R 4.7K J 1/16W	
R15			RK73HB1J102J	CHIP R 1.0K J 1/16W		R517			RK73HB1J182J	CHIP R 1.8K J 1/16W	
R16			RK73HB1J000J	CHIP R 0.0 J 1/16W		R519			RK73HB1J103J	CHIP R 10K J 1/16W	
R17			RK73HB1J471J	CHIP R 470 J 1/16W		R520			RK73HB1J474J	CHIP R 470K J 1/16W	
R18			RK73HB1J000J	CHIP R 0.0 J 1/16W		R521			RK73HB1J102J	CHIP R 1.0K J 1/16W	
R19			RK73HB1J272J	CHIP R 2.7K J 1/16W		R522			RK73HB1J101J	CHIP R 100 J 1/16W	
R20			RK73HB1J102J	CHIP R 1.0K J 1/16W		R523			RK73HB1J000J	CHIP R 0.0 J 1/16W	
R21			RK73HB1J152J	CHIP R 1.5K J 1/16W		R524			RK73HB1J394J	CHIP R 390K J 1/16W	
R22			RK73HB1J223J	CHIP R 22K J 1/16W		R525			RK73HB1J271J	CHIP R 270 J 1/16W	
R23			RK73HB1J103J	CHIP R 10K J 1/16W		R526			RK73HB1J000J	CHIP R 0.0 J 1/16W	
R24			RK73HB1J104J	CHIP R 100K J 1/16W		R527			RK73HB1J474J	CHIP R 470K J 1/16W	
R25-27			RK73HB1J473J	CHIP R 47K J 1/16W		R528			RK73HB1J102J	CHIP R 1.0K J 1/16W	
R28			RK73HB1J221J	CHIP R 220 J 1/16W		R529			RK73HB1J394J	CHIP R 390K J 1/16W	
R29			RK73HB1J471J	CHIP R 470 J 1/16W		R531			RK73HB1J101J	CHIP R 100 J 1/16W	
R30			RK73HB1J104J	CHIP R 100K J 1/16W		R532			RK73HB1J000J	CHIP R 0.0 J 1/16W	
R31			RK73HB1J472J	CHIP R 4.7K J 1/16W		R534			RK73HB1J221J	CHIP R 220 J 1/16W	
R32			RK73HB1J221J	CHIP R 220 J 1/16W		R535			RK73HB1J000J	CHIP R 0.0 J 1/16W	
R33			RK73HB1J101J	CHIP R 100 J 1/16W		R536			RK73HB1J561J	CHIP R 560 J 1/16W	
R34			RK73HB1J102J	CHIP R 1.0K J 1/16W		R537			RK73HB1J474J	CHIP R 470K J 1/16W	
R35			RK73HB1J124J	CHIP R 120K J 1/16W		R538			RK73HB1J224J	CHIP R 220K J 1/16W	
R37			RK73HB1J000J	CHIP R 0.0 J 1/16W		R539			RK73HB1J181J	CHIP R 180 J 1/16W	
R38			RK73HB1J101J	CHIP R 100 J 1/16W		R540			RK73HB1J473J	CHIP R 47K J 1/16W	
R40			RK73HB1J102J	CHIP R 1.0K J 1/16W		R541			RK73HB1J333J	CHIP R 33K J 1/16W	
R41			RK73HB1J103J	CHIP R 10K J 1/16W		R542			RK73HB1J000J	CHIP R 0.0 J 1/16W	
R42			RK73HB1J822J	CHIP R 8.2K J 1/16W		R543,544			RK73HB1J104J	CHIP R 100K J 1/16W	
R43-45			RK73HB1J101J	CHIP R 100 J 1/16W		R545			RK73HB1J102J	CHIP R 1.0K J 1/16W	
R46			RK73HB1J222J	CHIP R 2.2K J 1/16W		R546			RK73HB1J101J	CHIP R 100 J 1/16W	
R304			RK73HB1J102J	CHIP R 1.0K J 1/16W		R547			RK73HB1J000J	CHIP R 0.0 J 1/16W	
R307			RK73HB1J000J	CHIP R 0.0 J 1/16W		R549			RK73HB1J151J	CHIP R 150 J 1/16W	
R312			RK73HB1J472J	CHIP R 4.7K J 1/16W		R550			RK73HB1J103J	CHIP R 10K J 1/16W	
R314			RK73HB1J223J	CHIP R 22K J 1/16W		R551			RK73HB1J104J	CHIP R 100K J 1/16W	
R326			RK73HB1J123J	CHIP R 12K J 1/16W		R552			RK73HB1J473J	CHIP R 47K J 1/16W	
R331,332			RK73HB1J100J	CHIP R 10 J 1/16W		R553			RK73HB1J273J	CHIP R 27K J 1/16W	
R333,334			RK73HB1J101J	CHIP R 100 J 1/16W		R554,555			RK73HB1J104J	CHIP R 100K J 1/16W	
						R556			RK73FB2B000J	CHIP R 0.0 J 1/8W	

PARTS LIST

TX-RX UNIT (X57-8130-XX)

Ref. No.	Address	New parts	Parts No.	Description	Destination	Ref. No.	Address	New parts	Parts No.	Description	Destination
R557			RK73HB1J104J	CHIP R 100K J 1/16W		R771			RK73HB1J473J	CHIP R 47K J 1/16W	
R558			RK73HB1J473J	CHIP R 47K J 1/16W		R772			RK73HB1J103J	CHIP R 10K J 1/16W	
R559			RK73HB1J273J	CHIP R 27K J 1/16W		R773			RK73HB1J000J	CHIP R 0.0 J 1/16W	
R560			RK73HB1J000J	CHIP R 0.0 J 1/16W		R774			RK73HB1J472J	CHIP R 4.7K J 1/16W	
R701			RK73HB1J000J	CHIP R 0.0 J 1/16W		R775			RK73HB1J102J	CHIP R 1.0K J 1/16W	
R702,703			RK73HB1J101J	CHIP R 100 J 1/16W		R776			RK73HB1J152J	CHIP R 1.5K J 1/16W	
R704,705			RK73HB1J102J	CHIP R 1.0K J 1/16W		R777,778			RK73HB1J103J	CHIP R 10K J 1/16W	
R706			RK73HB1J000J	CHIP R 0.0 J 1/16W		R779-781			RK73HB1J473J	CHIP R 47K J 1/16W	
R707			RK73HB1J102J	CHIP R 1.0K J 1/16W		R782			RK73HB1J102J	CHIP R 1.0K J 1/16W	
R708			RK73HB1J000J	CHIP R 0.0 J 1/16W		R783			RK73HB1J393J	CHIP R 39K J 1/16W	
R710,711			RK73GH2A153D	CHIP R 15K D 1/10W		R784			RK73HB1J153J	CHIP R 15K J 1/16W	
R713			RK73HB1J821J	CHIP R 820 J 1/16W		R785			RK73HB1J123J	CHIP R 12K J 1/16W	
R714			RK73HB1J104J	CHIP R 100K J 1/16W		R786			RK73HB1J154J	CHIP R 150K J 1/16W	
R715			RK73HB1J681J	CHIP R 680 J 1/16W		R787			RK73HB1J124J	CHIP R 120K J 1/16W	
R716			RK73HB1J101J	CHIP R 100 J 1/16W		R789			RK73HB1J224J	CHIP R 220K J 1/16W	
R717			RK73HB1J103J	CHIP R 10K J 1/16W	M4	R790			RK73HB1J123J	CHIP R 12K J 1/16W	
R717			RK73HB1J183J	CHIP R 18K J 1/16W	K,M2,M3	R791			RK73GH2A124D	CHIP R 120K D 1/10W	
R718			RK73HB1J152J	CHIP R 1.5K J 1/16W		R792			RK73GH2A562D	CHIP R 5.6K D 1/10W	
R719			RK73HB1J122J	CHIP R 1.2K J 1/16W		R793			RK73GH2A913D	CHIP R 91K D 1/10W	
R721			RK73HB1J105J	CHIP R 1.0M J 1/16W	M4	R794			RK73HB1J124J	CHIP R 120K J 1/16W	
R721			RK73HB1J754J	CHIP R 750K J 1/16W	K,M2,M3	R795			RK73GH2A562D	CHIP R 5.6K D 1/10W	
R722			RK73HB1J152J	CHIP R 1.5K J 1/16W		R796			RK73HB1J183J	CHIP R 18K J 1/16W	
R723			RK73HB1J912J	CHIP R 9.1K J 1/16W		R797			RK73HB1J272J	CHIP R 2.7K J 1/16W	
R724			RK73HB1J682J	CHIP R 6.8K J 1/16W		R799			RK73HB1J474J	CHIP R 470K J 1/16W	
R725		*	RK73HB1J244J	CHIP R 240K J 1/16W		R800			RK73HB1J562J	CHIP R 5.6K J 1/16W	
R726			RK73HB1J183J	CHIP R 18K J 1/16W		R801			RK73HB1J000J	CHIP R 0.0 J 1/16W	
R727			RK73HB1J334J	CHIP R 330K J 1/16W		R802			RK73HB1J473J	CHIP R 47K J 1/16W	
R728			RK73HB1J823J	CHIP R 82K J 1/16W		R803			RK73HB1J392J	CHIP R 3.9K J 1/16W	
R729			RK73HB1J124J	CHIP R 120K J 1/16W		R804			RK73HB1J123J	CHIP R 12K J 1/16W	
R730			RK73HB1J823J	CHIP R 82K J 1/16W		R805			RK73HB1J562J	CHIP R 5.6K J 1/16W	
R733			RK73HB1J684J	CHIP R 680K J 1/16W		R806			RK73HB1J272J	CHIP R 2.7K J 1/16W	
R734			RK73HB1J224J	CHIP R 220K J 1/16W		R807			RK73HB1J105J	CHIP R 1.0M J 1/16W	
R735			RK73HB1J274J	CHIP R 270K J 1/16W		R808			RK73HB1J153J	CHIP R 15K J 1/16W	
R736,737			RK73HB1J103J	CHIP R 10K J 1/16W		R809			RK73HB1J471J	CHIP R 470 J 1/16W	
R738			RK73HB1J683J	CHIP R 68K J 1/16W		R810			RK73HB1J153J	CHIP R 15K J 1/16W	
R739			RK73HB1J223J	CHIP R 22K J 1/16W		R811			RK73HB1J000J	CHIP R 0.0 J 1/16W	
R740			RK73HB1J683J	CHIP R 68K J 1/16W		R812			RK73HB1J222J	CHIP R 2.2K J 1/16W	
R741			RK73HB1J154J	CHIP R 150K J 1/16W		R813			RK73HB1J473J	CHIP R 47K J 1/16W	
R742			RK73HB1J124J	CHIP R 120K J 1/16W		R814			RK73HB1J152J	CHIP R 1.5K J 1/16W	
R743-745			RK73HB1J102J	CHIP R 1.0K J 1/16W		R815			RK73HB1J472J	CHIP R 4.7K J 1/16W	
R746			RK73HB1J823J	CHIP R 82K J 1/16W		R816,817			RK73HB1J473J	CHIP R 47K J 1/16W	
R747			RK73HB1J104J	CHIP R 100K J 1/16W		R818			RK73HB1J683J	CHIP R 68K J 1/16W	
R748			RK73HB1J223J	CHIP R 22K J 1/16W		R819			RK73HB1J123J	CHIP R 12K J 1/16W	
R749			RK73HB1J562J	CHIP R 5.6K J 1/16W		R820			RK73HB1J221J	CHIP R 220 J 1/16W	
R750,751			RK73HB1J102J	CHIP R 1.0K J 1/16W		R821			RK73HB1J473J	CHIP R 47K J 1/16W	
R752-755			RK73HB1J473J	CHIP R 47K J 1/16W		R822			RK73HB1J334J	CHIP R 330K J 1/16W	
R756			RK73HB1J103J	CHIP R 10K J 1/16W		R823			RK73HB1J391J	CHIP R 390 J 1/16W	
R757			RK73HB1J473J	CHIP R 47K J 1/16W		R824			RK73HB1J474J	CHIP R 470K J 1/16W	
R758			RK73HB1J000J	CHIP R 0.0 J 1/16W		R825			RK73HB1J394J	CHIP R 390K J 1/16W	
R759			RK73HB1J102J	CHIP R 1.0K J 1/16W		R826			RK73HB1J473J	CHIP R 47K J 1/16W	
R760,761			RK73HB1J473J	CHIP R 47K J 1/16W		R827			RK73HB1J334J	CHIP R 330K J 1/16W	
R762			RK73HB1J103J	CHIP R 10K J 1/16W		R828,829			RK73HB1J000J	CHIP R 0.0 J 1/16W	
R763			RK73HB1J000J	CHIP R 0.0 J 1/16W		R830-833			RK73FB2B000J	CHIP R 0.0 J 1/8W	
R764			RK73GB2A000J	CHIP R 0.0 J 1/10W		R834			RK73HB1J102J	CHIP R 1.0K J 1/16W	
R765			RK73HB1J102J	CHIP R 1.0K J 1/16W		R835			RK73HB1J000J	CHIP R 0.0 J 1/16W	K
R766-768			RK73GB2A000J	CHIP R 0.0 J 1/10W	K	R836			RK73HB1J000J	CHIP R 0.0 J 1/16W	M2
R767,768			RK73GB2A000J	CHIP R 0.0 J 1/10W	M4	R837			RK73HB1J000J	CHIP R 0.0 J 1/16W	M3
R768			RK73GB2A000J	CHIP R 0.0 J 1/10W	M3	R838			RK73HB1J000J	CHIP R 0.0 J 1/16W	M4
R769			RK73HB1J102J	CHIP R 1.0K J 1/16W		R841,842			RK73HB1J103J	CHIP R 10K J 1/16W	
R770			RK73HB1J000J	CHIP R 0.0 J 1/16W		R843			RK73HB1J473J	CHIP R 47K J 1/16W	

PARTS LIST

TX-RX UNIT (X57-8130-XX)

Ref. No.	Address	New parts	Parts No.	Description	Destination	Ref. No.	Address	New parts	Parts No.	Description	Destination
R844			RK73HB1J103J	CHIP R 10K J 1/16W		IC710			XC6209B502P-G	MOS-IC	
R901			RK73HB1J000J	CHIP R 0.0 J 1/16W		IC711		*	TA7808F-NQ	ANALOGUE IC	
R902,903			RK73HB1J472J	CHIP R 4.7K J 1/16W		IC712			XC61CN4002MR	MOS-IC	
R904-906			RK73HB1J000J	CHIP R 0.0 J 1/16W		IC713			TA7805F-NQ	MOS-IC	
R908			RK73HB1J101J	CHIP R 100 J 1/16W		IC714		*	XC61CN3202MR	MOS-IC	
R909			RK73HB1J102J	CHIP R 1.0K J 1/16W		IC715	1A		LA4600	BI-POLAR IC	
R910-912			RK73HB1J103J	CHIP R 10K J 1/16W		IC901			PT6554LQ	MOS-IC	
R913			RK73HB1J563J	CHIP R 56K J 1/16W		Q1			2SA1832(GR)F	TRANSISTOR	
R914			RK73HB1J102J	CHIP R 1.0K J 1/16W		Q2			2SC4738(GR)F	TRANSISTOR	
R915			RK73HB1J152J	CHIP R 1.5K J 1/16W		Q3			2SC4649(N,P)	TRANSISTOR	
R916			RK73HB1J183J	CHIP R 18K J 1/16W		Q4			MCH3914(7)-H	FET	
R917			RK73HB1J392J	CHIP R 3.9K J 1/16W		Q5			2SJ347F	FET	
R918			RK73HB1J821J	CHIP R 820 J 1/16W		Q6			MCH3914(7)-H	FET	
R919			RK73HB1J272J	CHIP R 2.7K J 1/16W		Q7			UMC4N	TRANSISTOR	
R920			RK73HB1J183J	CHIP R 18K J 1/16W		Q8			KTC4075E(Y,GR)	TRANSISTOR	
R921			RK73HB1J104J	CHIP R 100K J 1/16W		Q9,10			2SC5108(Y)F	TRANSISTOR	
R922-924			RK73HB1J331J	CHIP R 330 J 1/16W		Q303			RD00HVS1-T113	FET	
VR901			R31-0662-05	VARIABLE RESISTOR		Q501			KTC4080E-P	TRANSISTOR	
D1			HZU5ALL	DIODE		Q502			2SC4617(S)	TRANSISTOR	
D2			DA2S101	DIODE		Q503			KTC4080E-P	TRANSISTOR	
D3-6		*	HVC359	VARIABLE CAPACITANCE DIODE		Q504			3SK318	FET	
D7			1SV278F	VARIABLE CAPACITANCE DIODE		Q505			3SK294-FP	FET	
D8			DA2S101	DIODE		Q506			2SK1830F	FET	
D9,10			HSC277	DIODE		Q701-703			2SC4919-S	TRANSISTOR	
D301			UDZW5.1(B)	ZENER DIODE		Q704,705			2SK3019	FET	
D305			DA2S101	DIODE		Q706			2SC2412K	TRANSISTOR	
D306,307			L407CDB	DIODE (50V/1W)		Q707-709			RT1N141U-T111	TRANSISTOR	
D309		*	JDP2S12CR	DIODE		Q710,711			2SB1694	TRANSISTOR	
D311		*	JDP2S12CR	DIODE		Q712			DTC363EU	DIGITAL TRANSISTOR	
D312			RB521S-30	DIODE		Q713			RT1N141U-T111	TRANSISTOR	
D313,314			HSB88AS-E	DIODE		Q714			2SJ645	FET	
D316			RB521S-30	DIODE		Q715			RT1N141U-T111	TRANSISTOR	
D501,502			MC2858-T111	DIODE		Q901			RT1P141U-T111	TRANSISTOR	
D503			HSB88AS-E	DIODE		Q902			RT1N141U-T111	TRANSISTOR	
D504			DA2S101	DIODE		Q903			2SB1132(Q,R)	TRANSISTOR	
D505,506			1SV325F	VARIABLE CAPACITANCE DIODE		Q904			UMG3N	TRANSISTOR	
D508,509			1SV325F	VARIABLE CAPACITANCE DIODE		TH501			NCP18WWM474J0S	THERMISTOR	
D702			MC2850	DIODE		TH702,703			NCP18WF104J03	THERMISTOR	
D704-706			MC2850	DIODE		S901			W02-3704-05	ENCODER	
D708			DA2S101	DIODE							
D709			1SS372F	DIODE							
D710			DA2S101	DIODE							
D711			1SS372F	DIODE							
D712			UDZW18(B)	ZENER DIODE							
D714			Z5W27V	SURGE ABSORBER							
D901			1SS355	DIODE							
D902			UDZW6.2(B)	ZENER DIODE							
IC1			MB15A02PFV2E1	MOS-IC							
IC2			UPB1509GV	BI-POLAR IC							
IC302	1B	*	RA60H1317M231	MOS-IC (POWER MODULE)							
IC303			NJM12904RB1	MOS-IC							
IC501			UA31136L	MOS-IC							
IC703			NJM2100V-ZB	MOS-IC							
IC704			NJM12904RB1	MOS-IC							
IC705			M62363FP-F	MOS-IC							
IC706			BA10324AFV	MOS-IC							
IC707			30622MEP540GU	MICROCONTROLLER IC							
IC708			EX24064ASAS0A	ROM IC							
IC709			BA10324AFV	MOS-IC							

If a part reference number is listed in a shaded box, that part does not come with the PCB.

TM-281A

EXPLODED VIEW

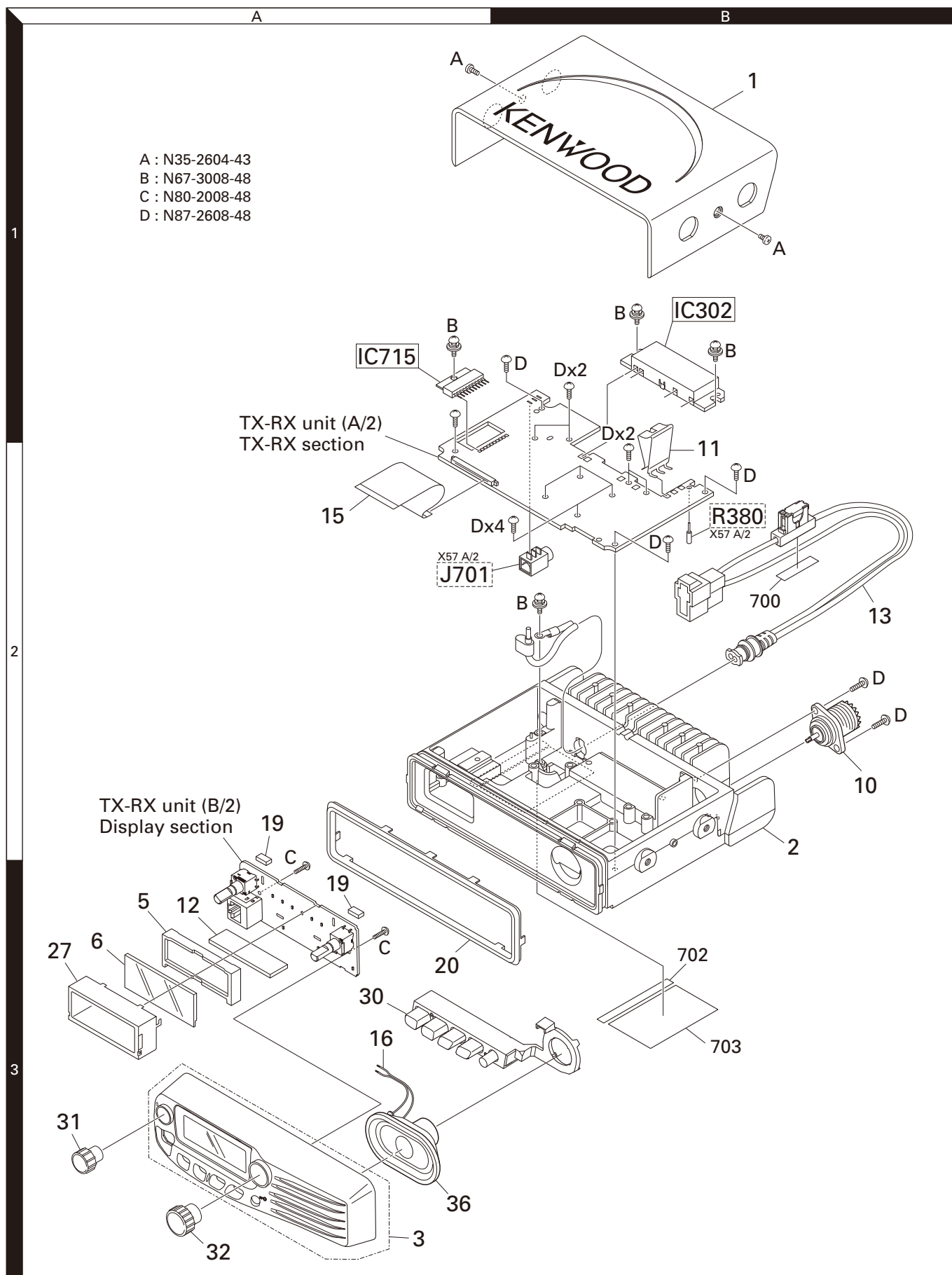

18 Parts with the exploded numbers larger than 700 are not supplied.
If a part reference number is listed in a box on the exploded view of the PCB, that part does not come with the PCB.
These parts must be ordered separately.

PACKING

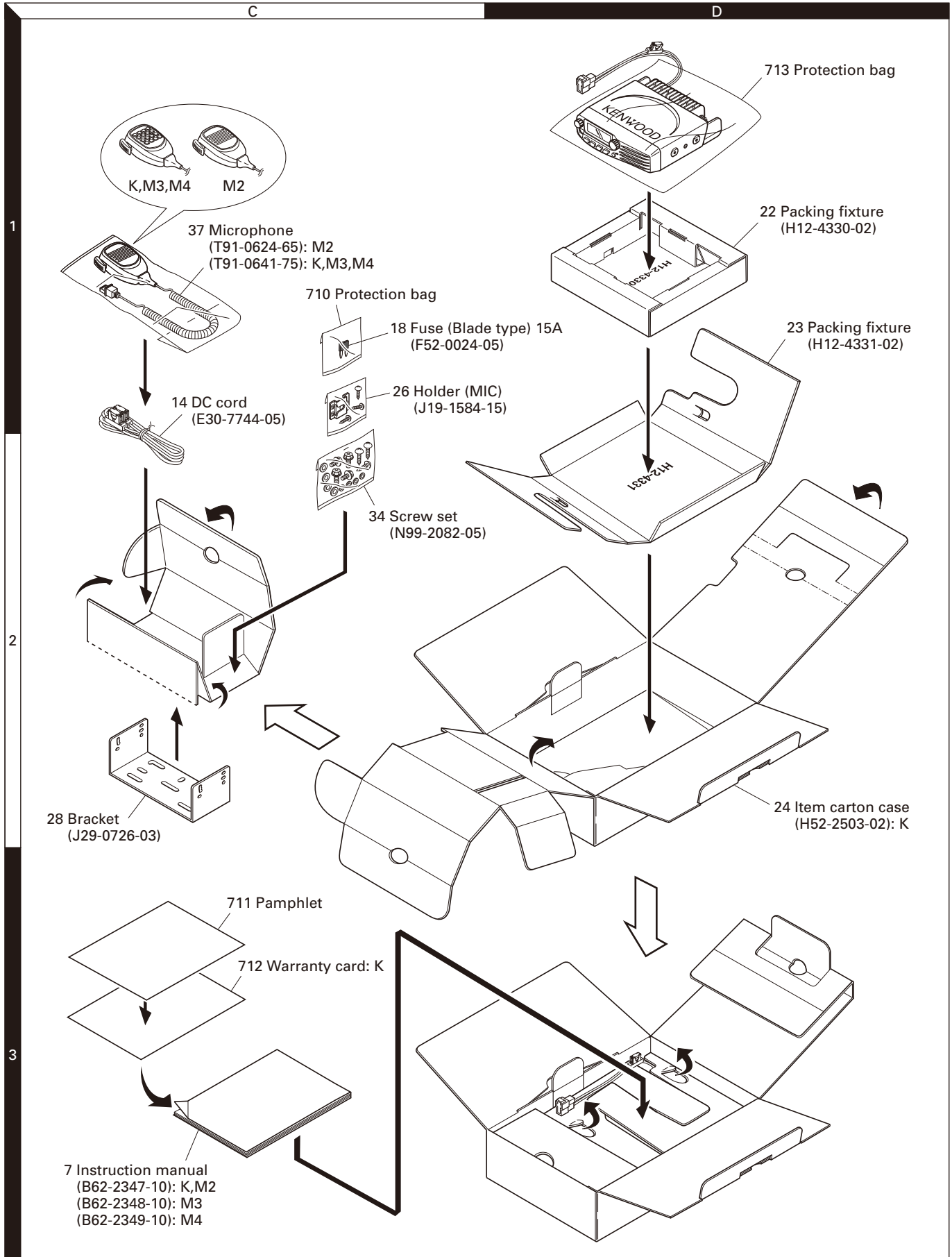

Parts with the exploded numbers larger than 700 are not supplied.

ADJUSTMENT

Measuring Equipment for Alignment

1. Digital voltmeter (DVM)

Input impedance: High

2. RF voltmeter (RF VM)

Input impedance: $1M\Omega$ or more, 2pF or less

Voltage range: Full scale=10mV to 300V

Measurable frequency range: Up to 200MHz

3. Frequency counter (f.counter)

Input sensitivity: About 50mV

Frequency range: 10Hz to 1000MHz

4. DC power supply

Voltage: Variable in the range 9 to 17V

Current: 14A or more

5. Power meter

Measurement power: 65W, 25W

Impedance: 50Ω

Measurable frequency: Up to 200MHz

6. AF voltmeter (AF VM)

Input impedance: $1M\Omega$ or more

Voltage range: Full scale=1mV to 30V

Measurable frequency range: 50Hz to 10kHz

7. AF generator (AG)

Output frequency: 100Hz to 10kHz

Output voltage: 0.5mV to 1V

8. Linear detector

Measurable frequency: Up to 200MHz

9. Spectrum analyzer

Measuring range: 10kHz to 1GHz or more

10. Oscilloscope

High sensitivity with horizontal input terminal

11. Standard signal generator (SSG)

Frequency range: 136 to 174MHz

Output: -133dBm ($0.05\mu\text{V}$) to greater than -13dBm (50mV)

12. Dummy load (for AF)

8Ω , about 5W

13. Sweep generator

The sweep generator must be able to sweep the frequency range of 30 to 300MHz.

14. Tracking generator

Output voltage: 100mV or more

Preparation

- Set the controls and switches to the positions listed below unless otherwise specified.

Volume control : Fully counterclockwise

Power switch : OFF

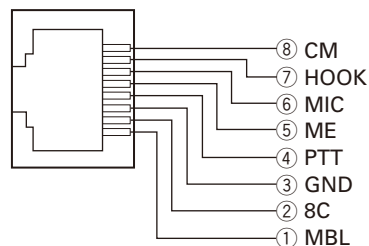

Microphone socket
(as viewed from the front of the transceiver)

- To protect the signal generator, never connect the microphone to the microphone socket when the receiver section is adjusted.
- Before the power cord is connected, make sure the power switch is off.
- Without specification of SSG, standard modulation is applied (MOD: 1kHz, DEV: $\pm 3\text{kHz}$)

ADJUSTMENT

Adjustment Mode

This mode is used to replace or readjust the EEPROM (IC708). In Adjustment Mode, the transceiver can be adjusted using its panel keys.

■ Items that can be adjusted in Adjustment Mode

- | | |
|----------------------------|------------------------|
| 1. Frequency Tune | 8. DTMF Fine Deviation |
| 2. Transmit High Power *1 | 9. Band Pass Tuning *3 |
| 3. Transmit Low Power *1 | 10. Squelch Tight *4 |
| 4. DCS Balance *2 | 11. Squelch Open *4 |
| 5. Max Deviation *2 | 12. S-Meter S1 Level |
| 6. CTCSS Fine Deviation *2 | 13. S-Meter Full Level |
| 7. DCS Fine Deviation *2 | |

Note:

- *1: Adjusted in 5 points in the transmission operating frequency range.
- *2: Adjusted in 3 points for the Wide bandwidth in the transmission operating frequency range.
Adjusted in 1 point for the Narrow bandwidth.
- *3: Adjusted in 3 points in the reception operating frequency range.
- *4: Adjusted in 3 points for the Wide bandwidth in the reception operating frequency range.
Adjusted in 1 point for the Narrow bandwidth.

■ How to Enter Adjustment Mode

To perform adjustments with the transceiver panel keys, the transceiver must be set to "Adjustment Mode".

While shorting two lands (GND, ADJ) on the component side of the TX-RX unit (A/2) using a pair of tweezers or similar tool, turn the transceiver power ON to enter Adjustment Mode.

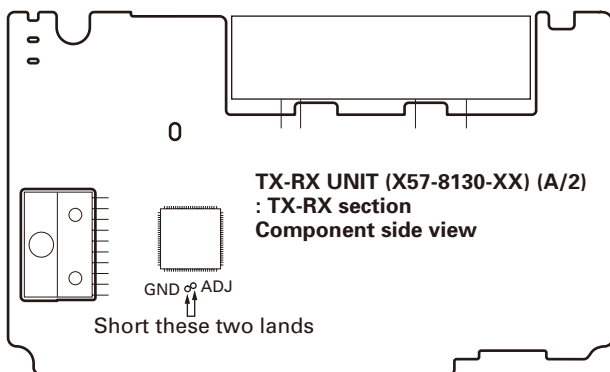

■ LCD Display in Adjustment Mode

Example of Frequency Tune. See "Table 1" for an LCD display list.

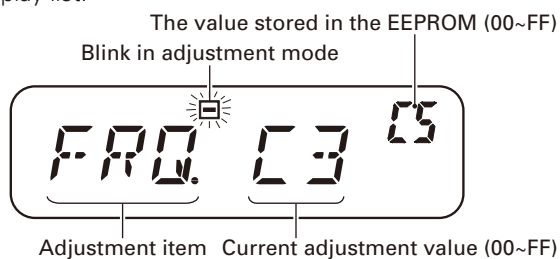

■ Panel Key Operation Method in Adjustment Mode

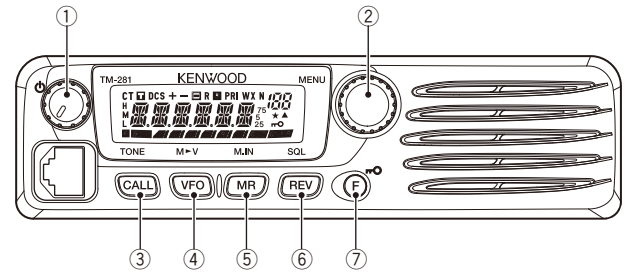

- ① Power switch/Volume control
- ② When the Tuning control is pressed once, the adjustment value display blinks. (Select an adjustment item with the [VFO] or [MR] key before performing the operation. It cannot be performed while transmitting.)
When the Tuning control is rotated while the adjustment display is blinking, the adjustment value changes. (Adjust transmission items while transmitting.)
When the Tuning control is pressed again, the adjustment value stops blinking and lights, and the adjustment value is saved in the memory of the transceiver. (For transmission item adjustment, enter receive mode before performing the operation.)
- ③ Changing between adjustment value display and frequency display
The display changes as follows: Adjustment value display → Transmit frequency display → Receive frequency display → Adjustment value display.
The frequency for adjustment can be confirmed.
- ④ Moves the adjustment item backward. (If it is operated when a frequency is displayed, the adjustment item display returns.)
- ⑤ Moves the adjustment item forward. (If it is operated when a frequency is displayed, the adjustment item display returns.)
- ⑥ If it is pressed before determining the adjustment value, the adjustment value of the Adjustment item returns to its original value.
- ⑦ Not used in Adjustment Mode.

Note:

If Max Power for transmission is low, check the DC cable. If the DC cable connector has poor contact due to rust or stain, a voltage drop may occur frequently and correct transmission power may not be supplied.

In this case, polish the DC cable connector. If the problem still persists, replace the DC cable with a new one.

ADJUSTMENT

No.	Adjustment Item	Adjustment Frequency Point	Display	Note	Transmit (MHz)	Receive (MHz)	Signaling
1	Frequency Tune	Center	<i>FPO</i>		155.100	155.050	
2	TX High Power	Low	<i>HPL</i>	"H" icon appear	136.100	136.050	
		Low'	<i>HPL I</i>		142.100	142.050	
		Center	<i>HPC</i>		150.100	150.050	
		High'	<i>HPH I</i>		156.100	156.050	
		High	<i>HPH</i>		173.900	173.950	
3	TX Low Power	Low	<i>LPL</i>	"L" icon appear	136.100	136.050	
		Low'	<i>LPL I</i>		142.100	142.050	
		Center	<i>LPC</i>		150.100	150.050	
		High'	<i>LPH I</i>		156.100	156.050	
		High	<i>LPH</i>		173.900	173.950	
4	DCS Balance	Low	<i>BALL</i>	"DCS" icon appear	136.100	136.050	DCS : 023N
		Center	<i>BALC</i>		155.100	155.050	
		High	<i>BALH</i>		173.900	173.950	
5	DCS Balance (Narrow)	Center	<i>BALC</i>	"DCS" and "N" icon appear	155.100	155.050	
6	Max Deviation	Low	<i>MAXL</i>		136.100	136.050	
		Center	<i>MAXC</i>		155.100	155.050	
		High	<i>MAXH</i>		173.900	173.950	
7	Max Deviation (Narrow)	Center	<i>MAXC</i>	"N" icon appear	155.100	155.050	
8	CTCSS Fine Deviation	Low	<i>DWL</i>	"CT" icon appear	136.100	136.050	CTCSS : 88.5Hz
		Center	<i>DWC</i>		155.100	155.050	
		High	<i>DWH</i>		173.900	173.950	
9	CTCSS Fine Deviation (Narrow)	Center	<i>DWC</i>	"CT" and "N" icon appear	155.100	155.050	
10	DCS Fine Deviation	Low	<i>DWL</i>	"DCS" icon appear	136.100	136.050	DCS : 023N
		Center	<i>DWC</i>		155.100	155.050	
		High	<i>DWH</i>		173.900	173.950	
11	DCS Fine Deviation (Narrow)	Center	<i>DWC</i>	"DCS" and "N" icons appear	155.100	155.050	
12	DTMF Fine Deviation	Center	<i>DT</i>		155.100	155.050	DTMF : 9
13	DTMF Fine Deviation (Narrow)	Center	<i>DT</i>	"N" icon appear	155.100	155.050	
14	Band Pass Tuning	Low	<i>BPL</i>	"BUSY" icon appear	136.100	136.050	
		Center	<i>BPC</i>		155.100	155.050	
		High	<i>BPH</i>		173.900	173.950	
15	Squelch Tight	Low	<i>SQTL</i>		136.100	136.050	
		Center	<i>SQTC</i>		146.100	146.050	
		High	<i>SQTH</i>		173.900	173.950	
16	Squelch Tight (Narrow)	Center	<i>SQTC</i>	"N" icon appear	146.100	146.050	
17	Squelch Open	Low	<i>SQOL</i>		136.100	136.050	
		Center	<i>SQOC</i>		146.100	146.050	
		High	<i>SQOH</i>		173.900	173.950	
18	Squelch Open (Narrow)	Center	<i>SQOC</i>	"N" icon appear	146.100	146.050	
19	S-Meter S1 Level	Center	<i>S 1</i>		146.100	146.050	
20	S-Meter Full Level	Center	<i>S 7</i>		146.100	146.050	

Table 1 Adjustment items, display and test frequency list

ADJUSTMENT

Adjustment Points

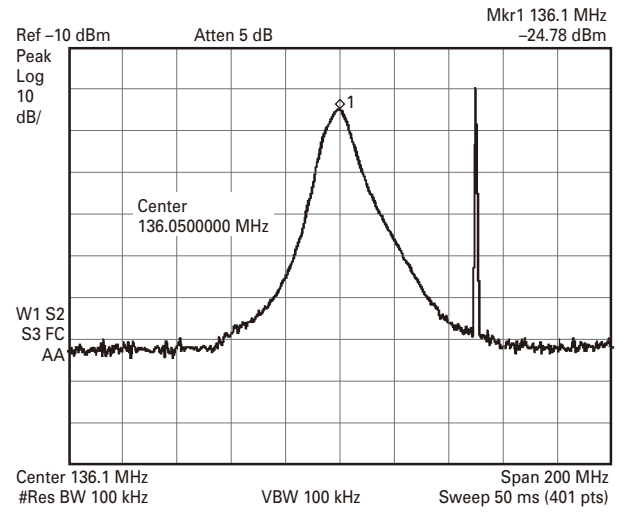
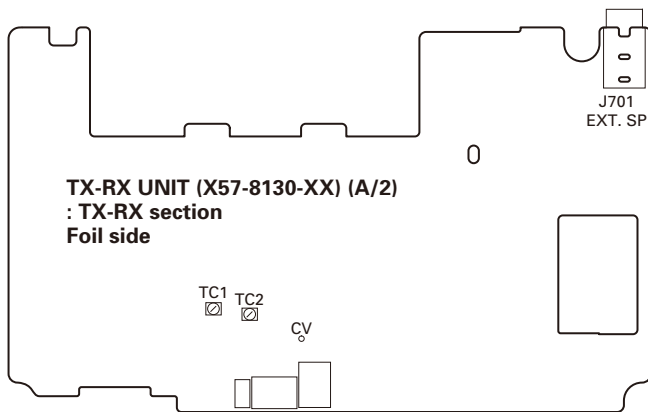
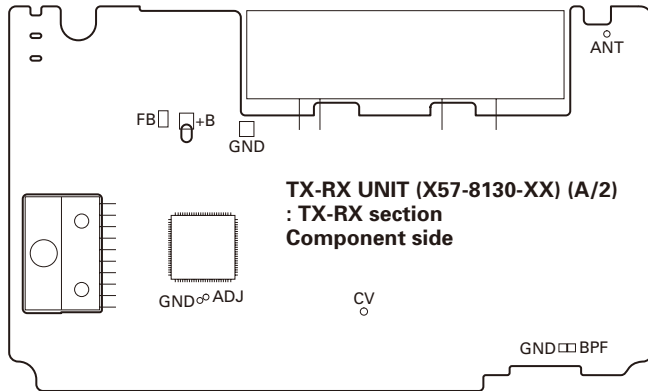

Fig. 1

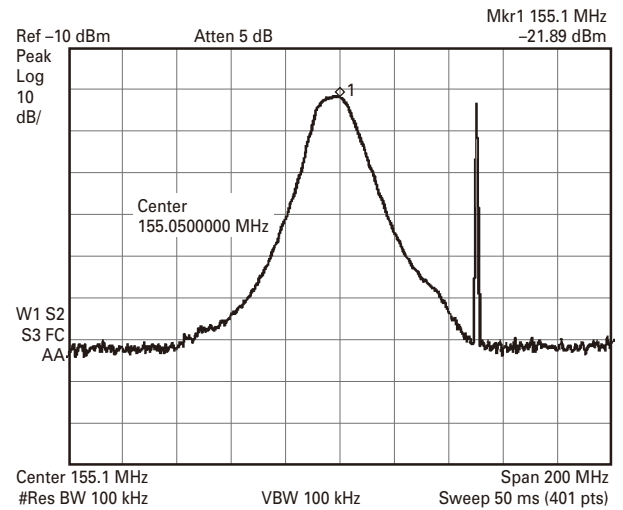

Fig. 2

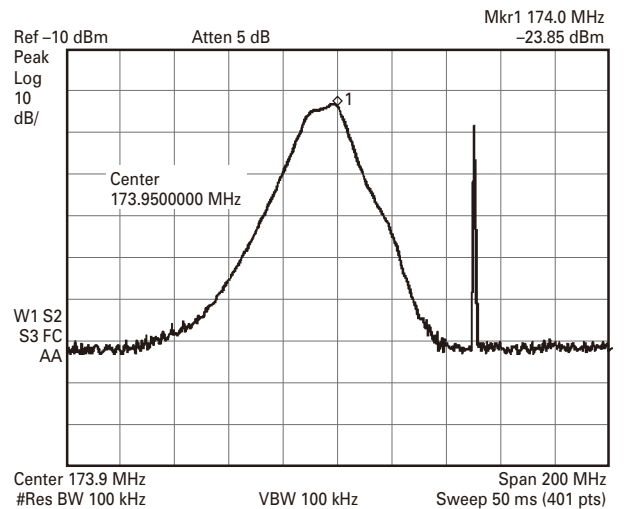



Fig. 3

ADJUSTMENT

Common Section

Item	Condition	Measurement			Adjustment			Specifications / Remarks
		Test-equipment	Unit	Terminal	Unit	Parts	Method	
1. Setting	1) Power supply voltage DC power supply terminal : 13.8V							
2. All LCD segments light check and full reset	<p>1) All LCD segments light check Turn the transceiver power ON by pressing the power switch while [F] key is pressed. While the [F] key is pressed, all LCD segments light.</p> <p>2) Full reset After confirming that all LCD segments have lighted described in the step 1 above, release the [F] key, "FL.RST?" appears on the display. Press the [F] key, "SURE ?" appears on the display. Press the [F] key again to perform the full reset.</p> <p>Note: When you do not want to remove data such as memory channel data, save the data using the MCP-1A (Memory control program) before performing the full reset, then write the data to the transceiver after performing the adjustment.</p>						<p>Confirm that all LCD segments light.</p> 	
3. VCO Lock voltage RX	1) Frequency: 173.950MHz	DVM	TX-RX (A/2)	CV	TX-RX (A/2)	TC2	5.5V	±0.1V
	2) Frequency: 136.050MHz						Check	0.5V or more
TX	3) Frequency: 173.900MHz 4) Transmit				TX-RX (A/2)	TC1	5.5V	±0.1V
	5) Frequency: 136.100MHz 6) Transmit						Check	0.5V or more

Transmitter Section (Refer to the Table 1 on page 22 for the frequencies which will apply in the adjustment mode.)

Item	Condition	Measurement			Adjustment			Specifications / Remarks	
		Test-equipment	Unit	Terminal	Unit	Parts	Method		
1. Frequency	1) Adj item: [FRQ.] Adjust: [**] 2) Transmit	f. counter	Rear panel	ANT	Front panel	Tuning control	Write	155.100MHz±50Hz	
2. High power [Low]	1) Adj item: [HPL.] Adjust: [**] 2) Transmit	Power meter						50W±1W	
	[Low']							3) Adj item: [HPL1.] Adjust: [**] 4) Transmit	65W±1W
	[Center]							5) Adj item: [HPC.] Adjust: [**] 6) Transmit	65W±1W
	[High']							7) Adj item: [HPH1.] Adjust: [**] 8) Transmit	50W±1W
	[High]							9) Adj item: [HPH.] Adjust: [**] 10) Transmit	50W±1W

ADJUSTMENT

Item	Condition	Measurement			Adjustment			Specifications / Remarks
		Test-equipment	Unit	Terminal	Unit	Parts	Method	
3. Low power [Low]	1) Adj item: [LPL .] Adjust: [**] 2) Transmit	Power meter	Rear panel	ANT	Front panel	Tuning control	Write	25W±1W
[Low']	3) Adj item: [LPL1.] Adjust: [**] 4) Transmit							
[Center]	5) Adj item: [LPC .] Adjust: [**] 6) Transmit							
[High']	7) Adj item: [LPH1.] Adjust: [**] 8) Transmit							
[High]	9) Adj item: [LPH .] Adjust: [**] 10) Transmit							
4. DCS balance	1) Adj item: [BALL.] Adjust: [**] Detector: +P HOLD LPF: 3kHz HPF: OFF De-emphasis: OFF 2) Transmit	Linear detector Oscilloscope					By turning the Tuning control, adjust the modulation wave until it becomes the square wave.	
• Wide [Low]	3) Adj item: [BALC.] Adjust: [**] 4) Transmit							
[Center]	5) Adj item: [BALH.] Adjust: [**] 6) Transmit							
• Narrow [Center]	7) Adj item: [BALC.] ("N" icon appear) Adjust: [**] 8) Transmit							
5. MAX deviation	1) Adj item: [MAXL.] Adjust: [**] AG: 1kHz/54mV K,M2,M3 AG: 1kHz/24mV M4 Detector: +P, -P LPF: 15kHz HPF: OFF De-emphasis: OFF 2) Transmit	Linear detector Oscilloscope	Rear panel	ANT			Write	4.0kHz±0.1kHz (According to the larger +P, -P)
• Wide [Low]	3) Adj item: [MAXC.] Adjust: [**] 4) Transmit							
[Center]	5) Adj item: [MAXH.] Adjust: [**] 6) Transmit							
• Narrow [Center]	7) Adj item: [MAXC.] ("N" icon appear) Adjust: [**] 8) Transmit							
		AG AF VM	Front panel	MIC				2.0kHz±0.05kHz (According to the larger +P, -P)

ADJUSTMENT

Item	Condition	Measurement			Adjustment			Specifications / Remarks
		Test-equipment	Unit	Terminal	Unit	Parts	Method	
6. MIC sensitivity (Narrow)	1) Frequency: 155.100MHz AG: 1kHz/5.4mV K,M2,M3 AG: 1kHz/2.4mV M4 Detector: P-P/2 LPF: 15kHz HPF: OFF De-emphasis: OFF 2) Transmit	Linear detector Oscilloscope	Rear panel	ANT			Check	±1.2~1.9kHz
		AG AF VM	Front panel	MIC				
7. CTCSS fine deviation	1) Adj item: [DVL.] ("CT" icon appear) Detector: P-P/2 LPF: 3kHz HPF: OFF De-emphasis: OFF 2) Transmit	Linear detector Oscilloscope	Rear panel	ANT	Front panel	Tuning control	Write	0.75kHz±0.05kHz
• Wide [Low]								
[Center]	3) Adj item: [DVC.] ("CT" icon appear) Adjust: [**] 4) Transmit							
[High]	5) Adj item: [DVH.] ("CT" icon appear) Adjust: [**] 6) Transmit							
• Narrow [Center]	7) Adj item: [DVC.] ("CT" and "N" icon appear) Adjust: [**] 8) Transmit							0.37kHz±0.05kHz
8. DCS fine deviation	1) Adj item: [DVL.] ("DCS" icon appear) Detector: P-P/2 LPF: 3kHz HPF: OFF De-emphasis: OFF 2) Transmit							0.75kHz±0.05kHz
• Wide [Low]								
[Center]	3) Adj item: [DVC.] ("DCS" icon appear) Adjust: [**] 4) Transmit							
[High]	5) Adj item: [DVH.] ("DCS" icon appear) Adjust: [**] 6) Transmit							
• Narrow [Center]	7) Adj item: [DVC.] ("DCS" and "N" icon appear) Adjust: [**] 8) Transmit							0.35kHz±0.05kHz
9. DTMF fine deviation	1) Adj item: [DT.] Detector: P-P/2 LPF: 15kHz HPF: OFF De-emphasis: OFF 2) Transmit							3.0kHz±0.1kHz
• Wide								
• Narrow	3) Adj item: [DT.] ("N" icon appear) Adjust: [**] 4) Transmit							1.5kHz±0.1kHz

ADJUSTMENT

Receiver Section (Refer to the Table 1 on page 22 for the frequencies which will apply in the adjustment mode.)

Item	Condition	Measurement			Adjustment			Specifications / Remarks	
		Test-equipment	Unit	Terminal	Unit	Parts	Method		
1. Band Pass Tuning [Low]	1) Adj item: [BPL.] Adjust: [**]	Spectrum analyzer	Rear panel	ANT	Front panel	Tuning control	By turning the Tuning control, adjust the band-pass filter waveform as shown.	Refer to Fig. 1 (page 23).	
	2) Spectrum analyzer setting Center-f: 136.050MHz Span: 200MHz RBW: 100kHz VBW: 100kHz ATT: 5dB	Tracking generator	TX-RX (A/2)	BPF					
	3) Tracking generator output : -30dBm								
[Center]	4) Adj item: [BPC.] Adjust: [**]							Refer to Fig. 2 (page 23).	
	5) Spectrum analyzer setting Center-f: 155.050MHz Span: 200MHz RBW: 100kHz VBW: 100kHz ATT: 5dB								
	6) Tracking generator output : -30dBm								
[High]	7) Adj item: [BPH.] Adjust: [**]							Refer to Fig. 3 (page 23).	
	8) Spectrum analyzer setting Center-f: 173.950MHz Span: 200MHz RBW: 100kHz VBW: 100kHz ATT: 5dB								
	9) Tracking generator output : -30dBm								
2. Squelch Tight • Wide [Low]	1) Adj item: [SCTL.] Adjust: [**]	SSG Oscilloscope	Rear panel	ANT		Write			
	2) SSG output : -116dBm (0.35μV) SSG MOD: 1kHz SSG DEV: 3kHz	AF VM Distortion meter		EXT. SP					
	[Center]	3) Adj item: [SQTC.] Adjust: [**]							
		4) SSG output : -116dBm (0.35μV)							
[High]	5) Adj item: [SQTH.] Adjust: [**]								
	6) SSG output : -116dBm (0.35μV)								
• Narrow [Center]	7) Adj item: [SQTC.] ("N" icon appear) Adjust: [**]								
	8) SSG output : -116dBm (0.35μV) SSG MOD: 1kHz SSG DEV: 1.5kHz								

ADJUSTMENT

Item	Condition	Measurement			Adjustment			Specifications / Remarks
		Test-equipment	Unit	Terminal	Unit	Parts	Method	
3. Squelch Open • Wide [Low]	1) Adj item: [SQOL.] 2) SSG output : -124dBm (0.14μV) SSG MOD: 1kHz SSG DEV: 3kHz	SSG Oscilloscope AF VM Distortion meter	Rear panel	ANT	Front panel	Tuning control	Write	
	[Center]			EXT. SP				
	[High]							
	• Narrow [Center]							
	3) Adj item: [SQOC.] Adjust: [**] 4) SSG output : -124dBm (0.14μV)							
	5) Adj item: [SQOH.] Adjust: [**] 6) SSG output : -124dBm (0.14μV)							
	7) Adj item: [SQOC.] ("N" icon apper) Adjust: [**] 8) SSG output : -124dBm (0.14μV) SSG MOD: 1kHz SSG DEV: 1.5kHz							
4. RSSI writing	1) Frequency: 155.050MHz 2) SSG output: -53dBm (501μV) SSG MOD: 1kHz SSG DEV: 3kHz						RSSI value writing is performed by the "Squelch open" item (center wide). SSG output level is changed and adjusted after Squelch adjustment. This adjustment should not turn the Tuning control.	
5. S-meter S1	1) Adj item: [S1.] Adjust: [**] 2) SSG output : -118dBm (0.28μV) SSG MOD: 1kHz SSG DEV: 3kHz						Write	
6. S-meter Full scale	1) Adj item: [S7.] Adjust: [**] 2) SSG output : -96dBm (3.54μV) SSG MOD: 1kHz SSG DEV: 3kHz							

TERMINAL FUNCTION

TX-RX unit (X57-8130-XX A/2) : TX-RX Section

Pin No.	Name	I/O	Function
CN702			
1	SPGND	-	AF GND
2	SPGND	-	AF GND
3	SPOUT	O	AF out
4	SPOUT	O	AF out
5	8C	O	8V DC supply
6	RXD	I	RXD/ PC serial data
7	PTT	I	PTT/ PC serial data
8	VOL	I	Volume
9	MICKEY	I	Microphone key
10	5C	O	5V DC supply
11	CM	I	Microphone key check
12	ENCA	I	Encoder A
13	ENCB	I	Encoder B
14	DI	I	Data from LCD driver
15	DO	O	Data for LCD driver
16	CE	O	Chip enable for LCD driver
17	CL	O	Clock for LCD driver
18	BRI	O	LCD brightness control
19	POWER	I	Power key
20	MIC	I	Microphone
21	ME	-	GND
22	GND	-	GND
J701 (EXT. SP jack)			
1	EXT SP	O	External speaker
2	GND	-	GND

TX-RX unit (X57-8130-XX B/2) : Display Section

Pin No.	Name	I/O	Function
CN901			
1	SPGND	-	AF GND
2	SPGND	-	AF GND
3	SPOUT	I	AF out
4	SPOUT	I	AF out
5	8C	I	8V DC supply
6	RXD	O	RXD/ PC serial data
7	PTT	O	PTT/ PC serial data
8	VOL	O	Volume
9	MICKEY	O	Microphone key
10	5C	I	5V DC supply
11	CM	O	Microphone key check
12	ENCA	O	Encoder A
13	ENCB	O	Encoder B
14	DI	O	Data from LCD driver
15	DO	I	Data for LCD driver
16	CE	I	Chip enable for LCD driver
17	CL	I	Clock for LCD driver
18	BRI	I	LCD brightness control
19	POWER	O	Power key
20	MIC	O	Microphone
21	ME	-	GND
22	GND	-	GND
J901 (MIC jack)			
1	MBL	O	Key detection
2	8C	O	Switched 8V for MIC
3	GND	-	GND
4	PTT	I	PTT/ PC serial data
5	ME	-	MIC GND
6	MIC	I	MIC signal input
7	HOOK	I	HOOK/ PC serial data
8	CM	I	MIC data detection

TM-281A PC BOARD

TX-RX UNIT (X57-8130-XX) (A/2): TX-RX SECTION

-10: K -21: M2 -22: M3 -23: M4

Component side view (J79-0316-09 A/2)

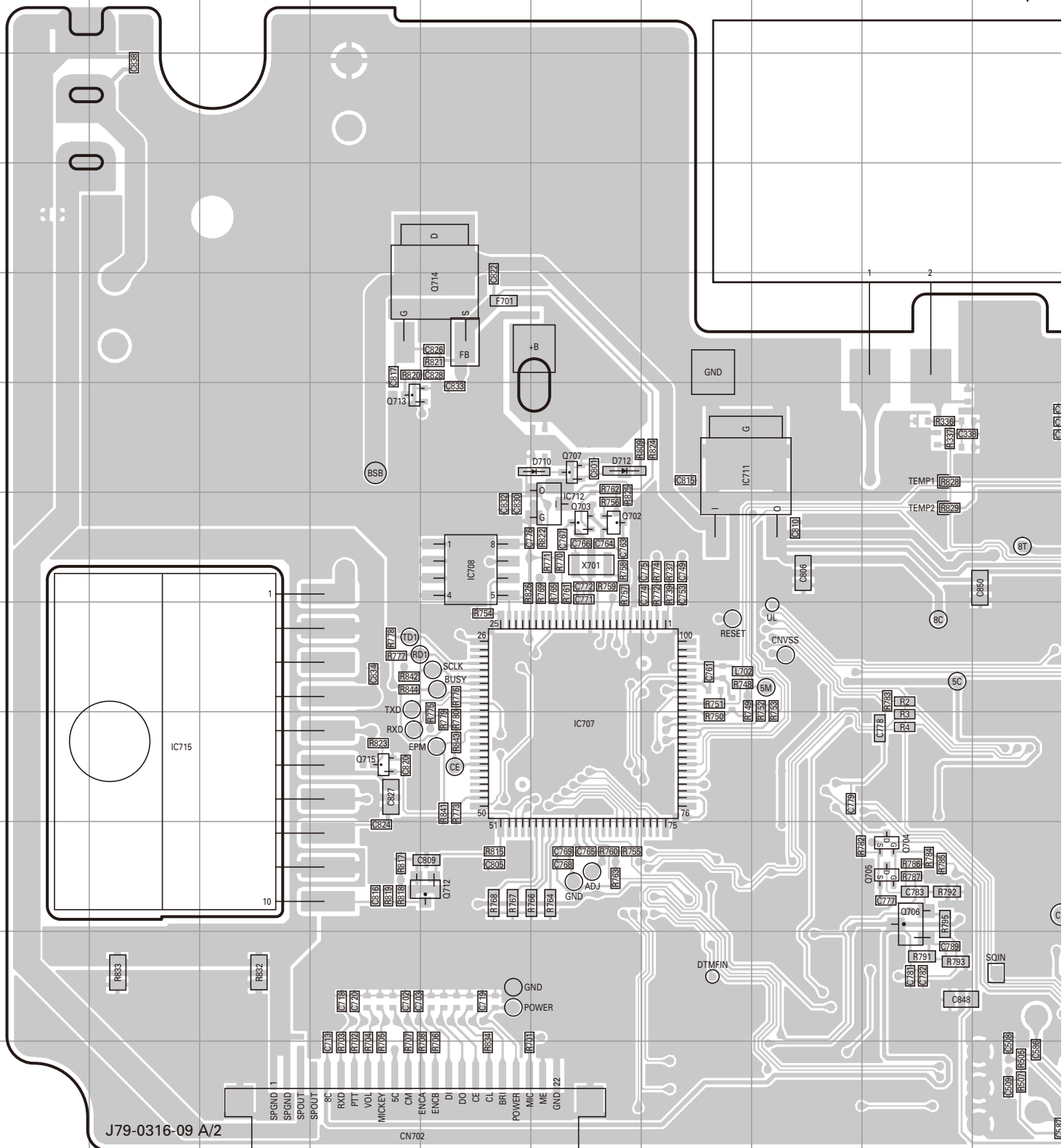

PC BOARD TM-281A

TX-RX UNIT (X57-8130-XX) (A/2): TX-RX SECTION
-10: K -21: M2 -22: M3 -23: M4
Component side view (J79-0316-09 A/2)

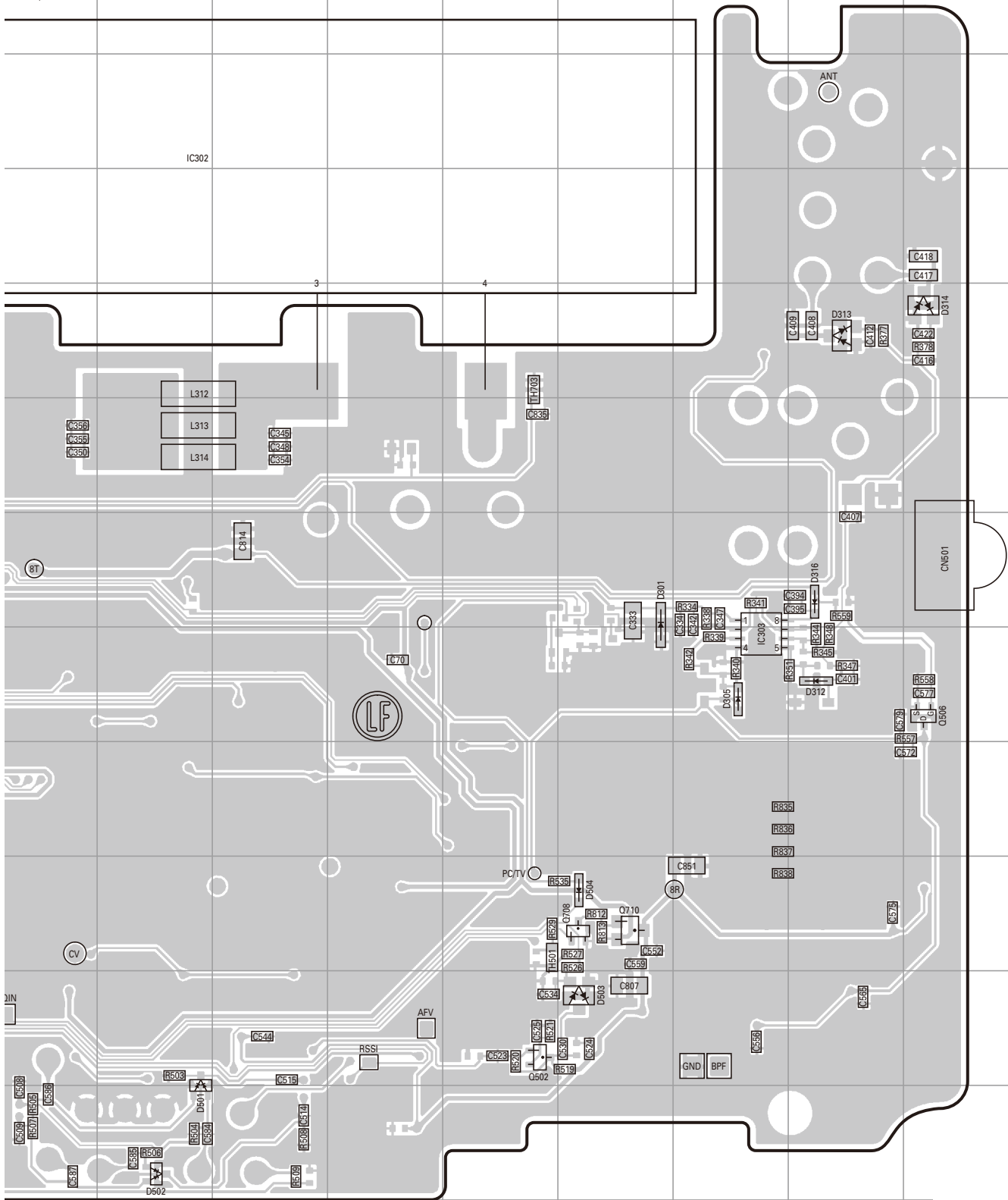

Ref. No.	Address
IC302	3K
IC303	8P
IC707	9F
IC708	7E
IC711	6G
IC712	7F
IC715	9B
Q502	11N
Q506	8R
Q702	7F
Q703	7F
Q704	10I
Q705	10I
Q706	10I
Q707	6F
Q708	10O
Q710	10O
Q712	10E
Q713	6D
Q714	5E
Q715	9D
D301	7O
D305	8P
D312	8Q
D313	5Q
D314	5R
D316	7Q
D501	12K
D502	12K
D503	11O
D504	10O
D710	6F
D712	6F

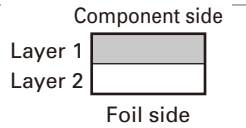

TM-281A PC BOARD

TX-RX UNIT (X57-8130-XX) (A/2): TX-RX SECTION

-10: K -21: M2 -22: M3 -23: M4

Foil side view (J79-0316-09 A/2)

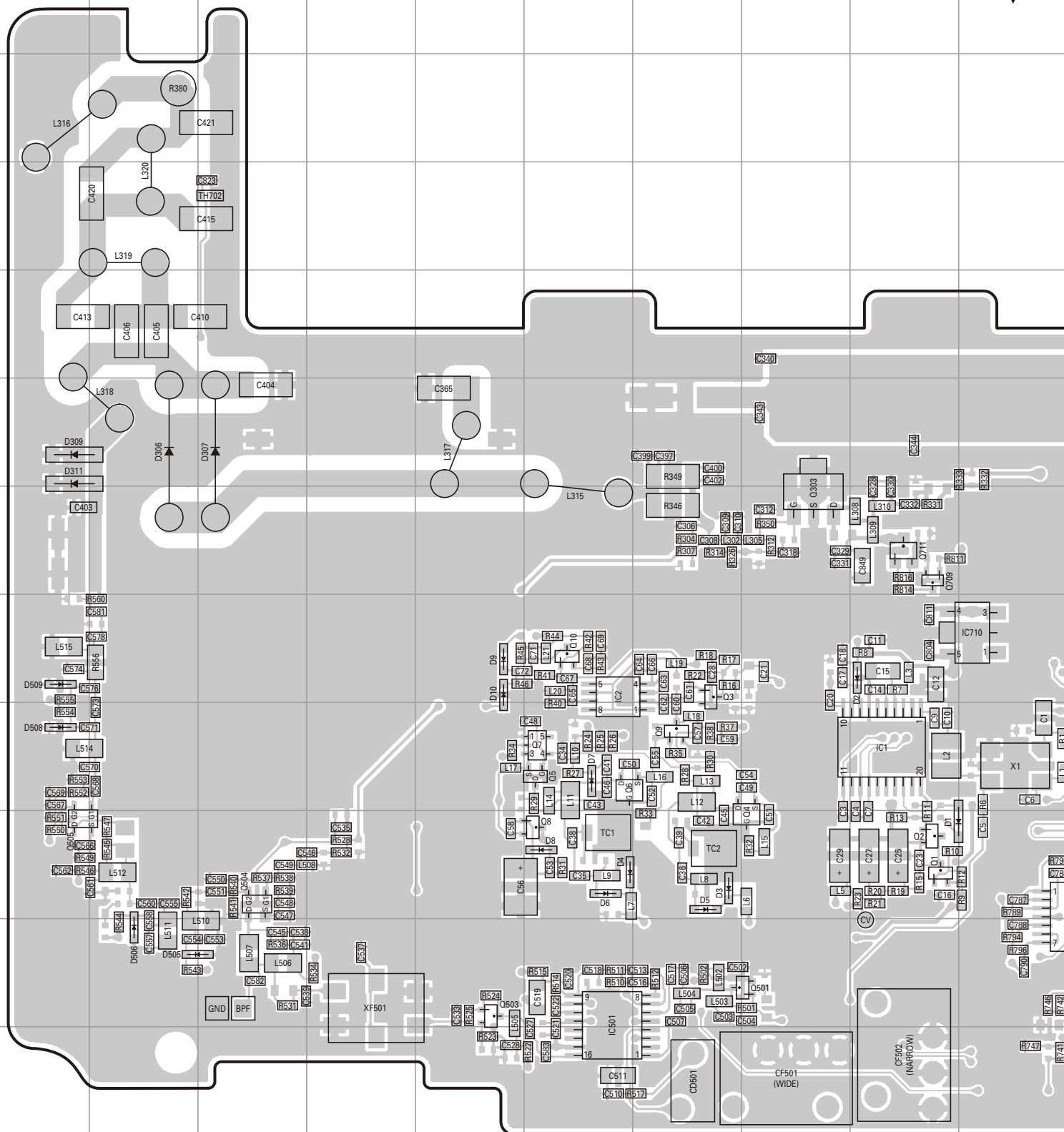

PC BOARD TM-281A

TX-RX UNIT (X57-8130-XX) (A/2): TX-RX SECTION
-10: K -21: M2 -22: M3 -23: M4
Foil side view (J79-0316-09 A/2)

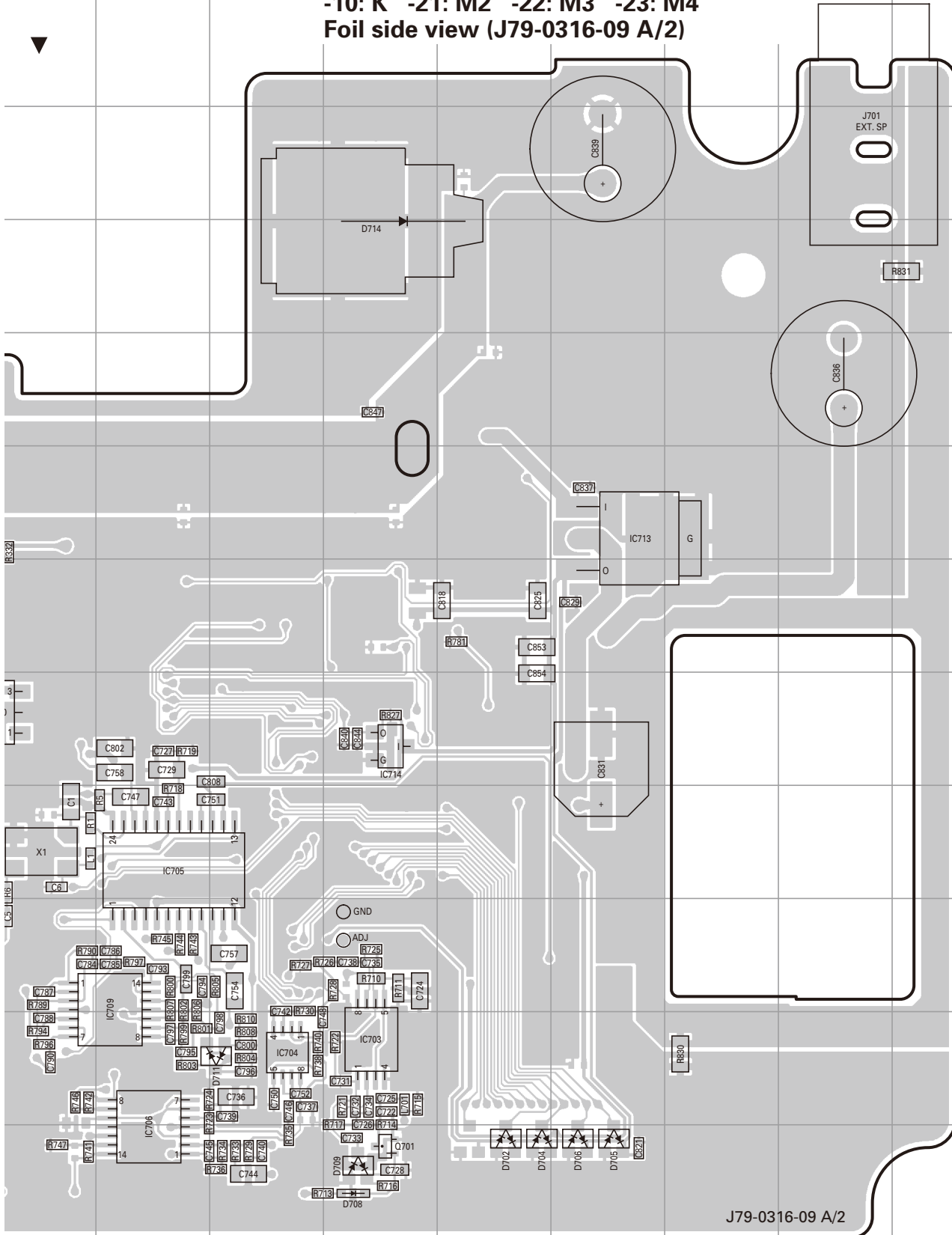

Ref. No.	Address
IC1	9I
IC2	8F
IC501	11F
IC703	11M
IC704	11L
IC705	9K
IC706	12K
IC709	10K
IC710	8J
IC713	6O
IC714	8M
Q1	10I
Q2	10I
Q3	8G
Q4	10H
Q5	9F
Q6	9F
Q7	9F
Q8	10F
Q9	9G
Q10	8F
Q303	7H
Q501	11H
Q503	11E
Q504	10C
Q505	10A
Q701	12M
Q709	7I
Q711	7I
D1	10I
D2	8I
D3	10G
D4	10F
D5	10G
D6	10F
D7	9F
D8	10F
D9	8E
D10	8E
D306	6B
D307	6C
D309	6A
D311	6A
D505	11B
D506	11B
D508	9A
D509	8A
D702	12N
D704	12N
D705	12O
D706	12O
D708	12M
D709	12M
D711	11L
D714	4M

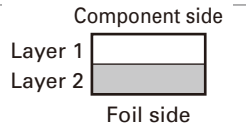

TM-281A PC BOARD

TX-RX UNIT (X57-8130-XX) (B/2): DISPLAY SECTION

-10: K -21: M2 -22: M3 -23: M4

Component side view (J79-0316-09 B/2)

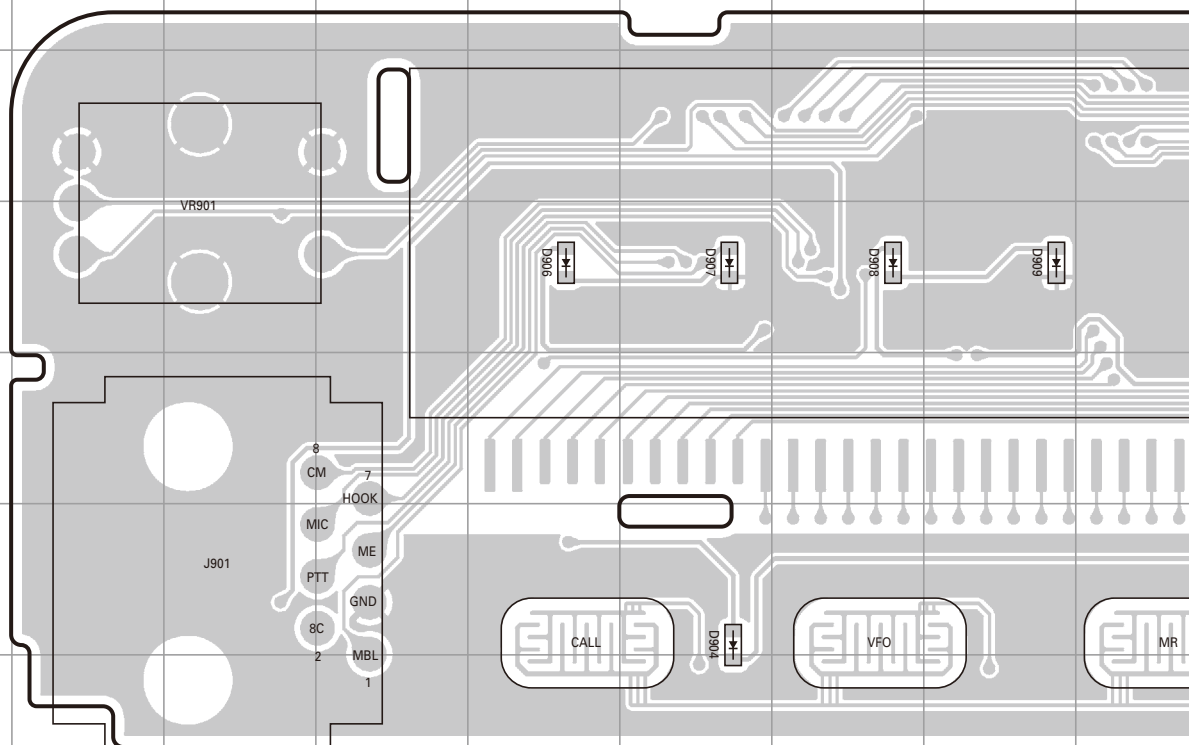

TX-RX UNIT (X57-8130-XX) (B/2): DISPLAY SECTION

-10: K -21: M2 -22: M3 -23: M4

Foil side view (J79-0316-09 B/2)

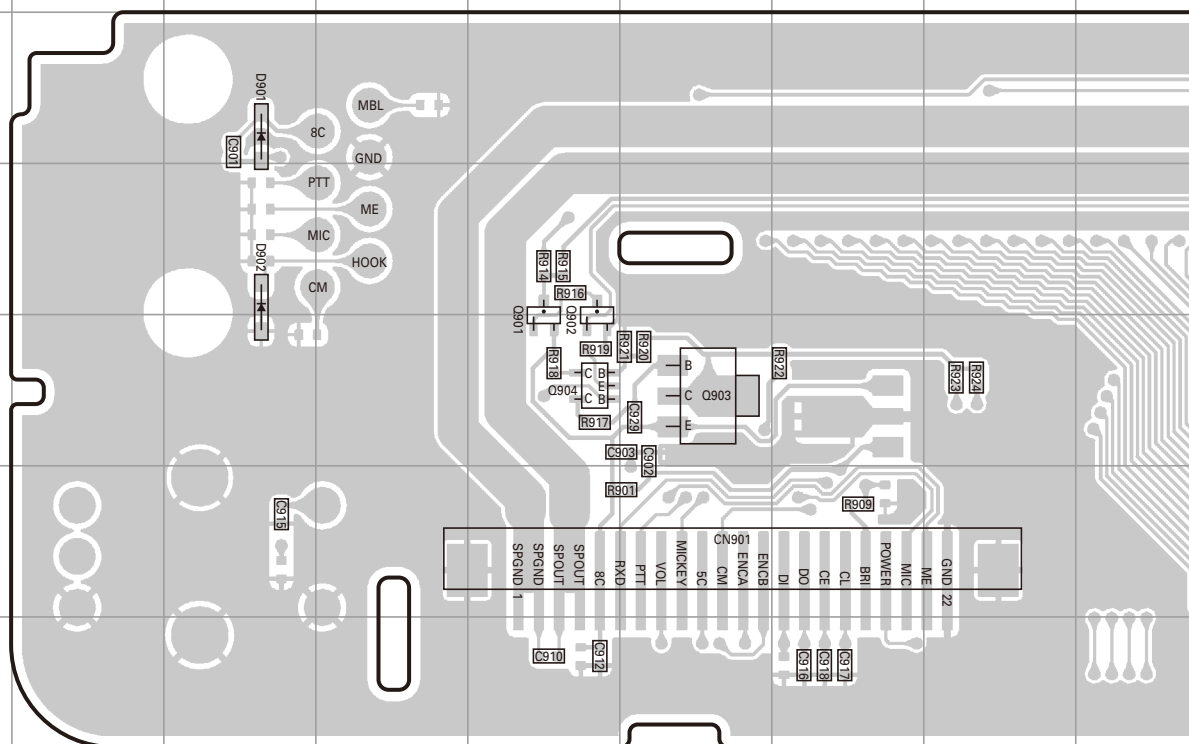

PC BOARD TM-281A

TX-RX UNIT (X57-8130-XX) (B/2): DISPLAY SECTION -10: K -21: M2 -22: M3 -23: M4 Component side view (J79-0316-09 B/2)

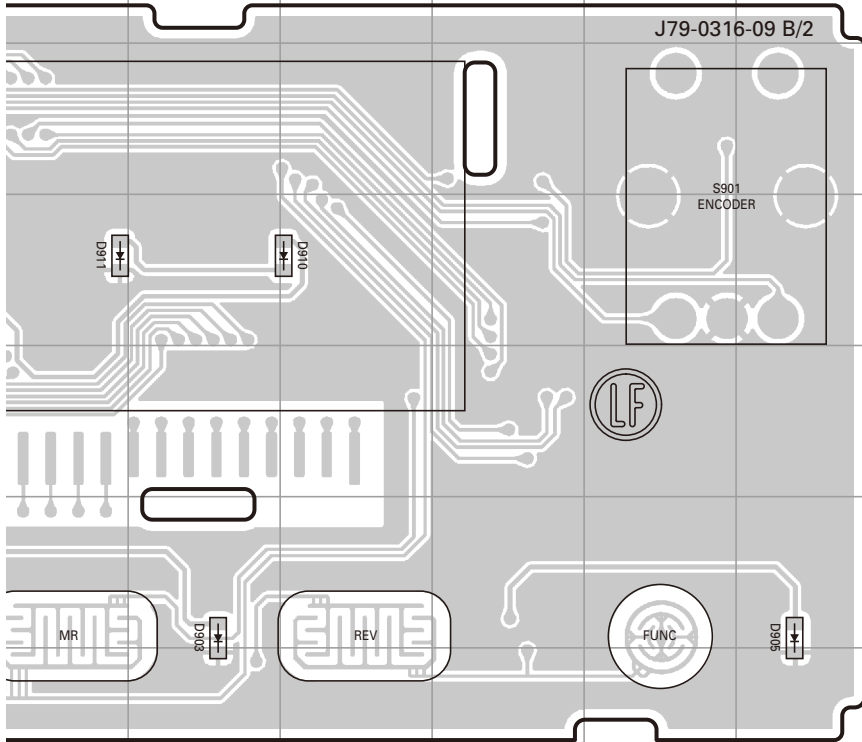

Ref. No.	Address
D903	6K
D904	6G
D905	6O
D906	4F
D907	4G
D908	4H
D909	4I
D910	4L
D911	4J

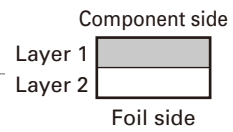

TX-RX UNIT (X57-8130-XX) (B/2): DISPLAY SECTION -10: K -21: M2 -22: M3 -23: M4 Foil side view (J79-0316-09 B/2)

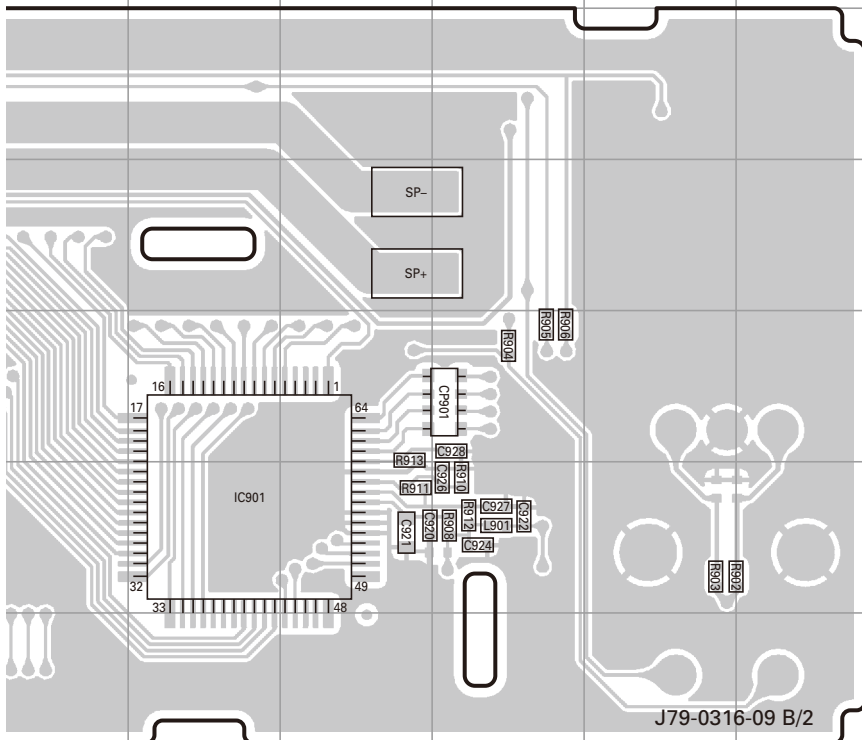

Ref. No.	Address
IC901	12K
Q901	11F
Q902	11F
Q903	11G
Q904	11F
D901	9D
D902	10D

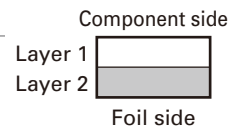

TM-281A SCHEMATIC DIAGRAM

TX-RX UNIT (X57-8130-XX)(A/2) : TX-RX SECTION

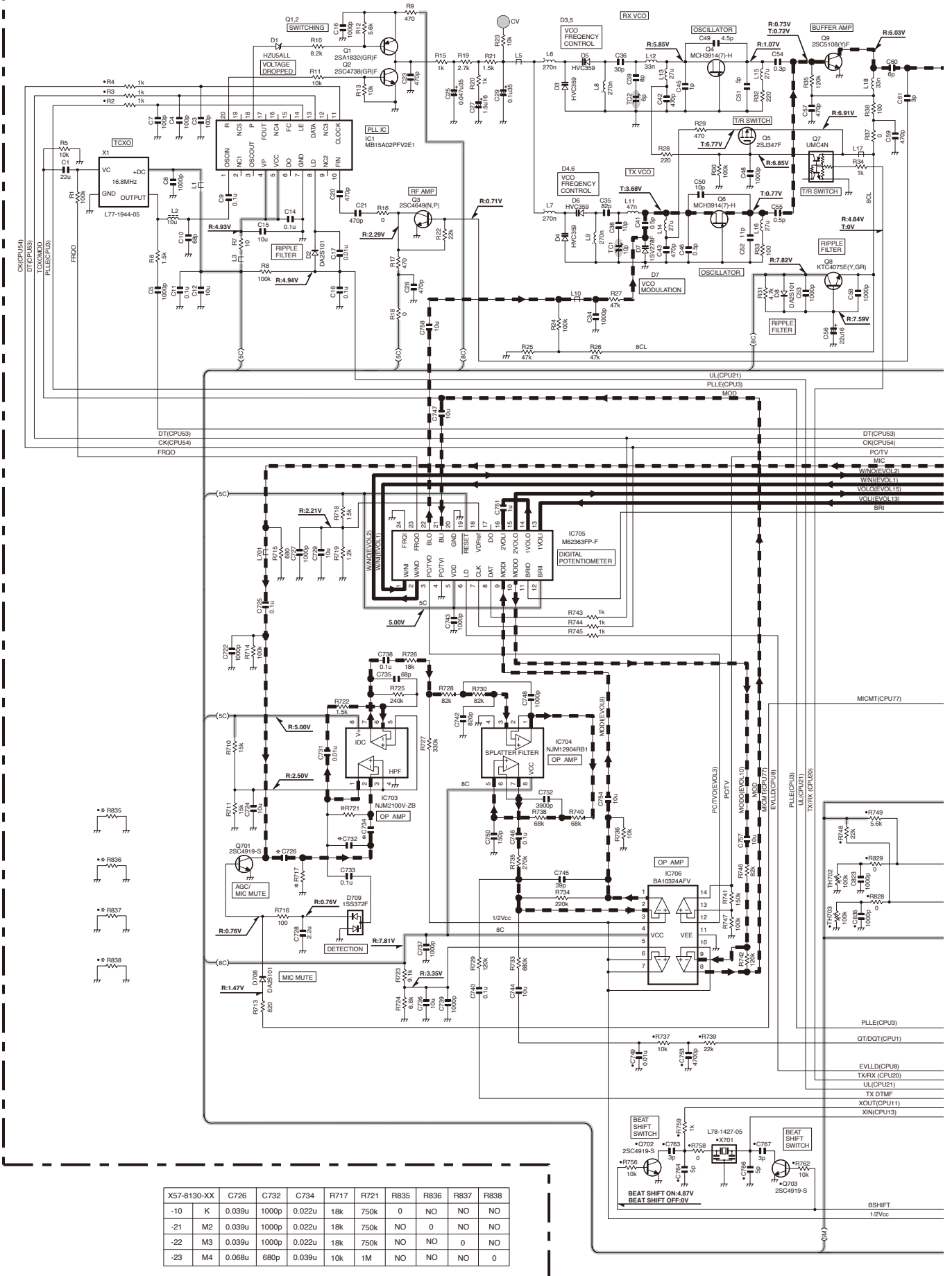

X57-8130-XX	C726	C732	C734	R717	R721	R835	R836	R837	R838
-10	K	0.039u	1000p	0.022u	18k	750k	0	NO	NO
-21	M2	0.039u	1000p	0.022u	18k	750k	NO	0	NO
-22	M3	0.039u	1000p	0.022u	18k	750k	NO	0	NO
-23	M4	0.068u	680p	0.039u	10k	1M	NO	NO	NO

SCHEMATIC DIAGRAM TM-281A

TX-RX UNIT (X57-8130-XX)(A/2): TX-RX SECTION

	X57-8130-XX	R766	R767	R768
-10	K	0	0	0
-21	M2	NO	NO	NO
-22	M3	NO	NO	0
-23	M4	NO	0	0

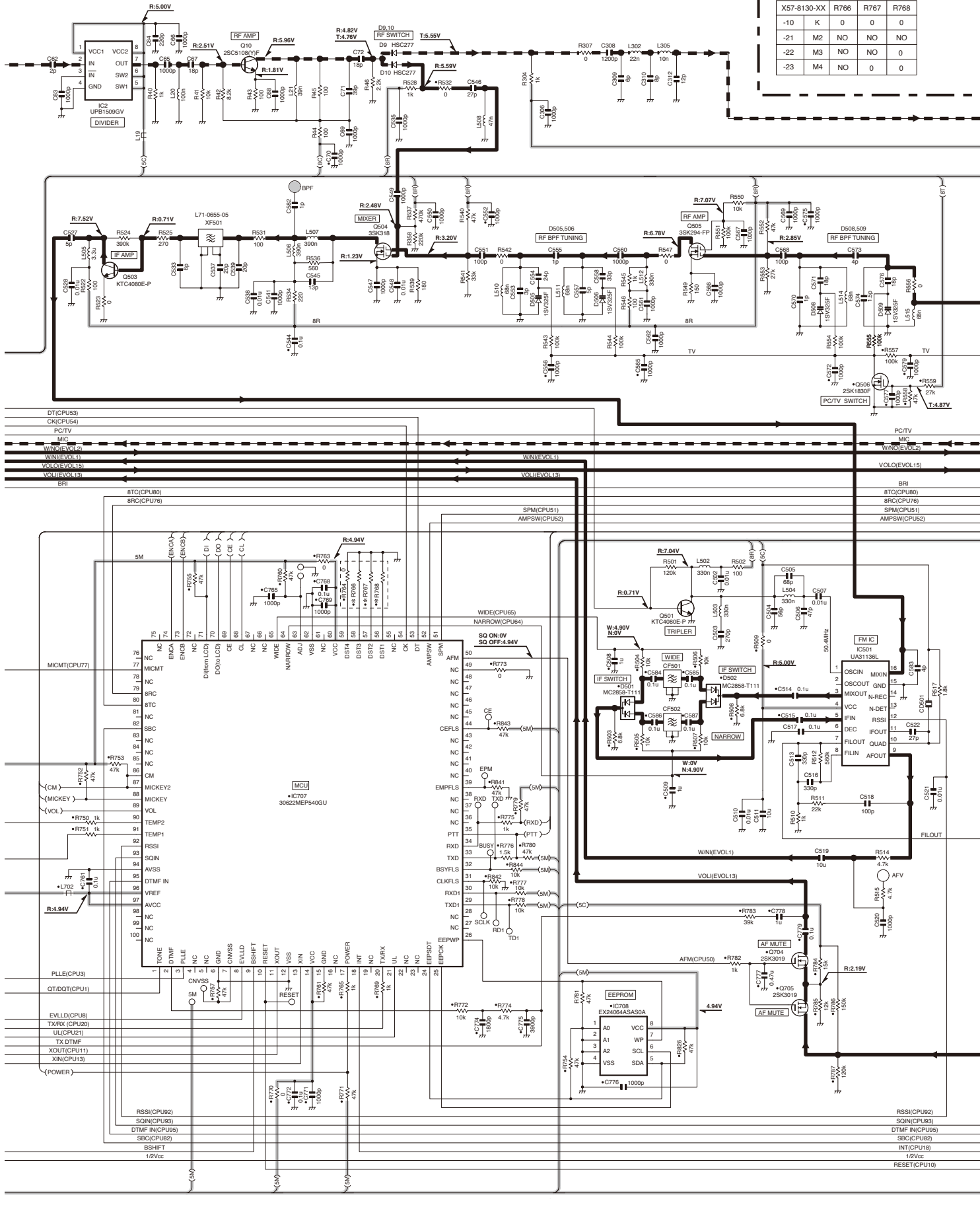

TM-281A SCHEMATIC DIAGRAM

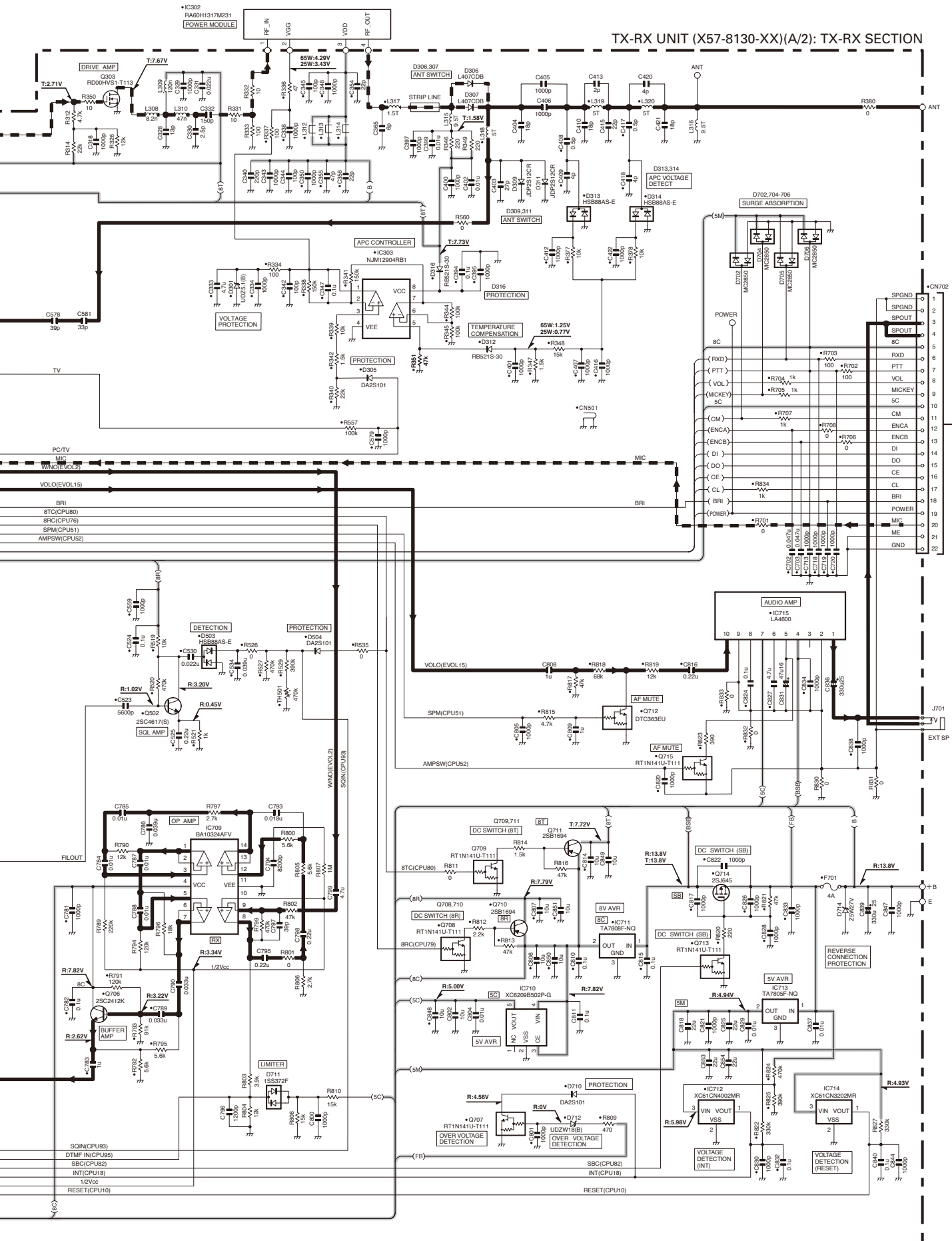

SCHEMATIC DIAGRAM TM-281A

TX-RX UNIT (X57-8130-XX)(B/2) : DISPLAY SECTION

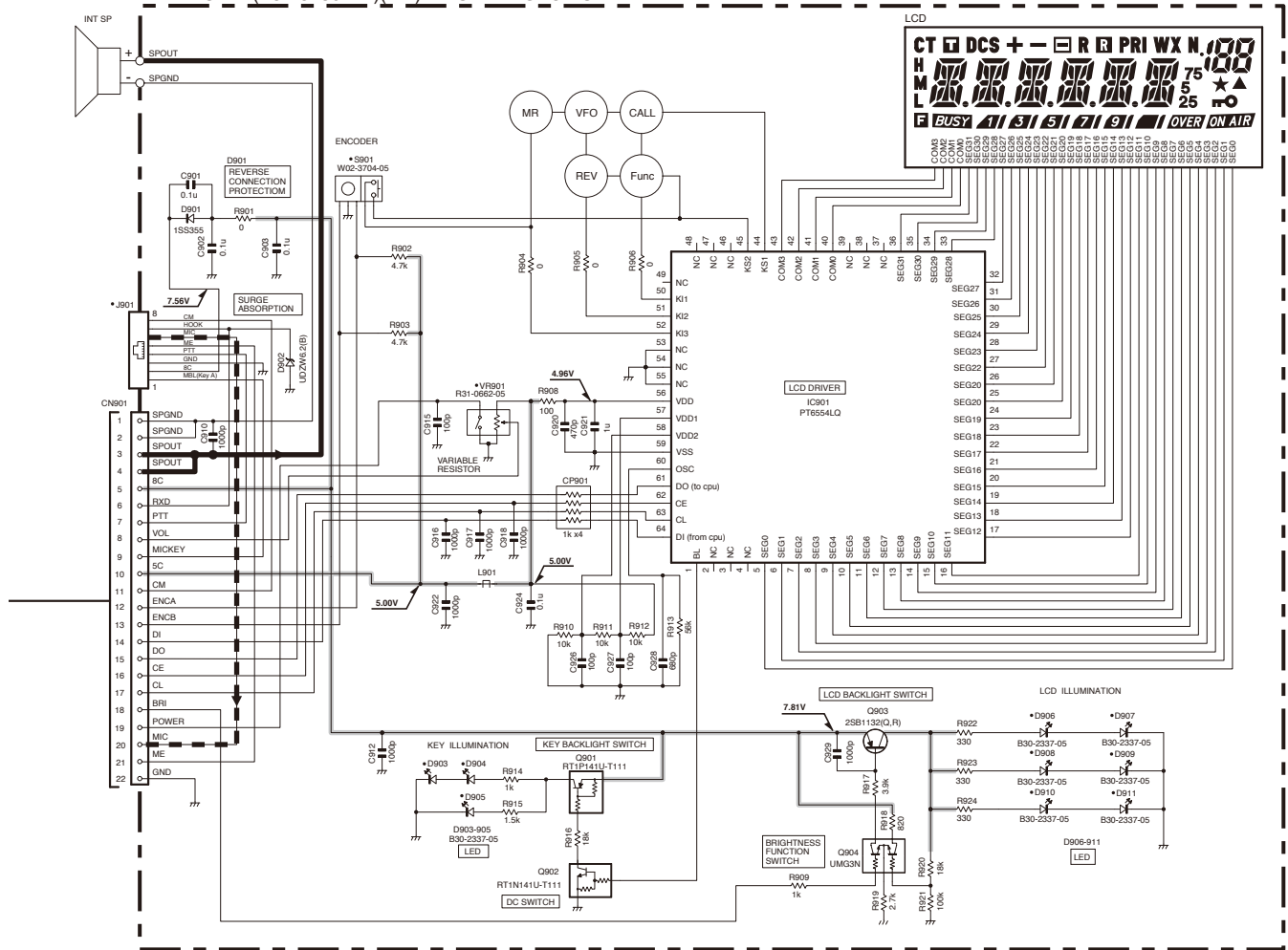

Note: The components marked with a dot (•) are parts of layer 1.

BLOCK DIAGRAM

TX-RX UNIT (X57-8130-XX B/2): Display section

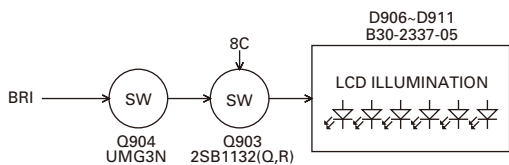
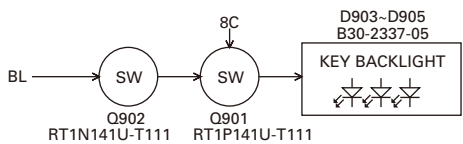
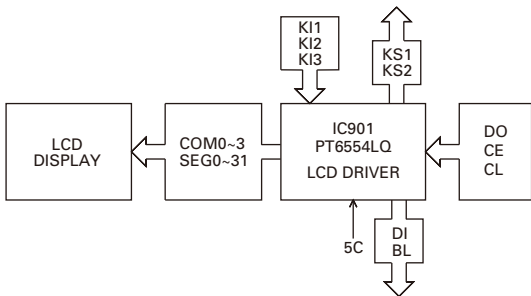
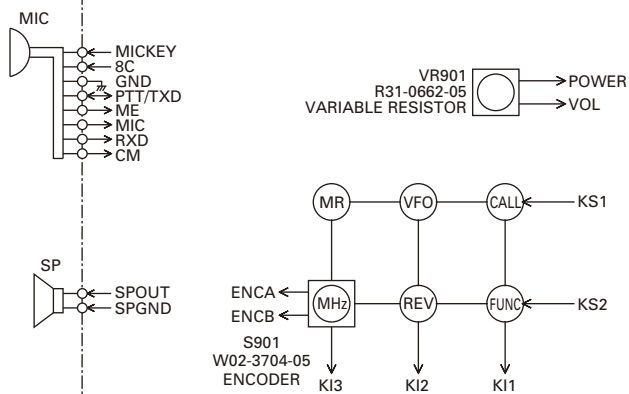

TX-RX UNIT (X57-8130-XX A/2): TX-RX section

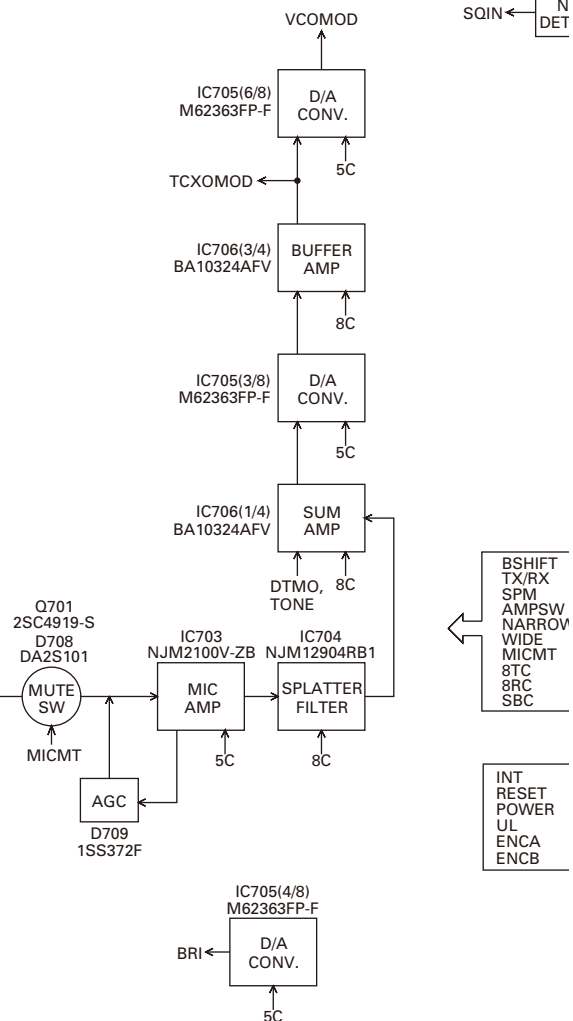
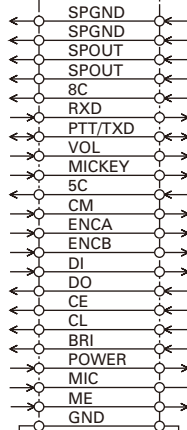
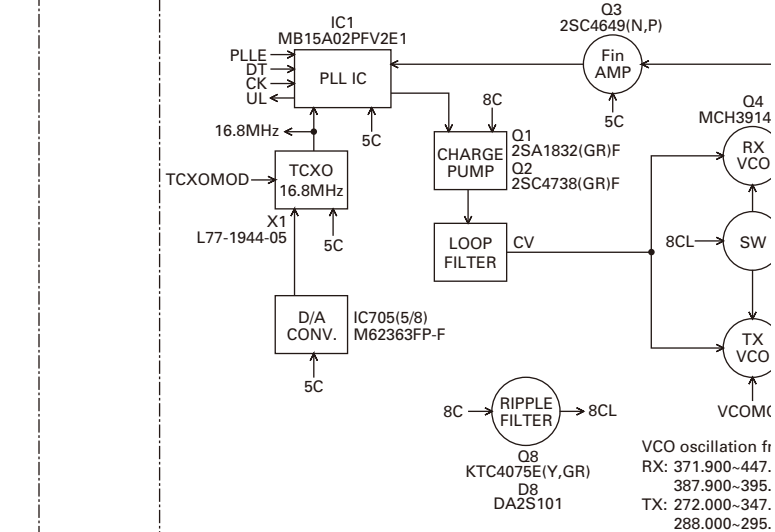

BLOCK DIAGRAM

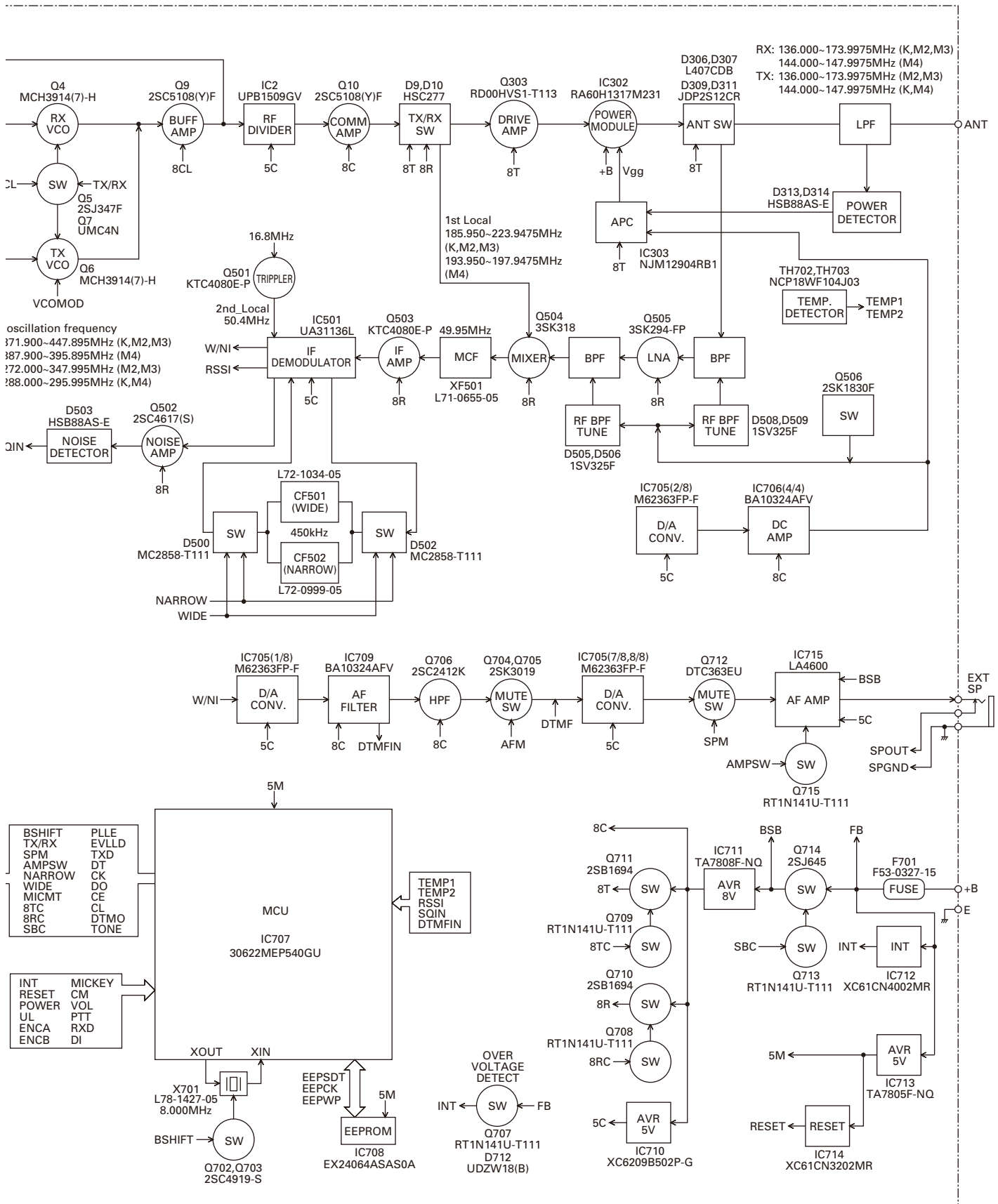

LEVEL DIAGRAM

Receiver Section

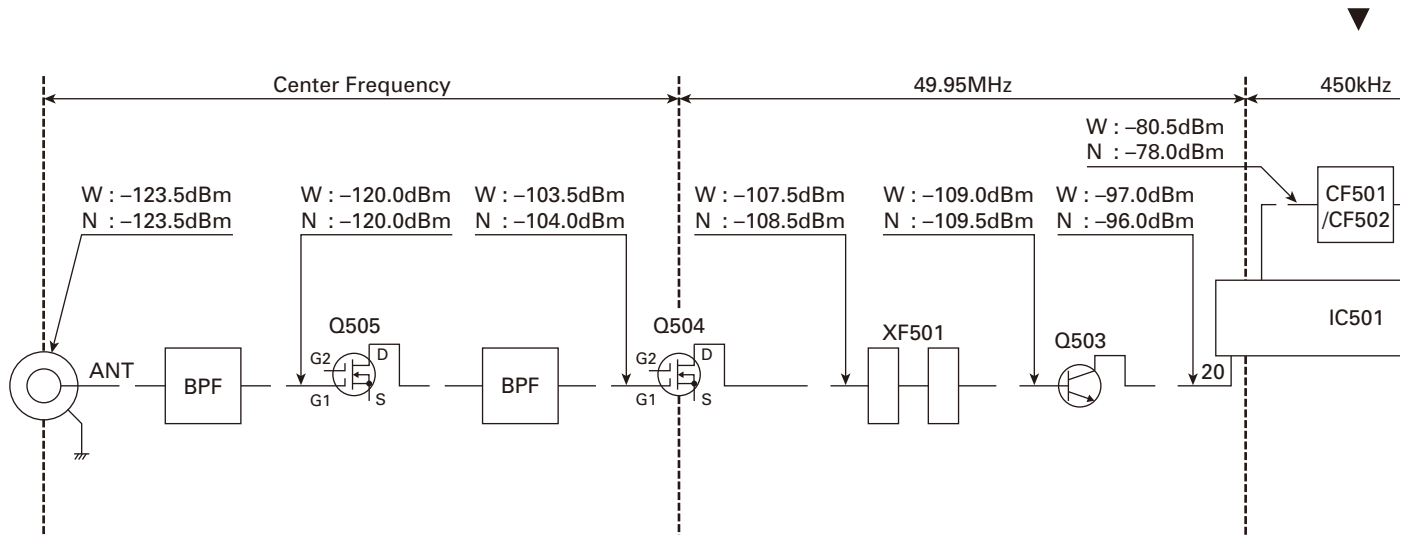

To make measurements in the RF section, connect the RF level meter in the RF section, use a 0.01 μ F coupling capacitor. (The display shows the SSG input value required to obtain 12dB SIN.)

Transmitter Section

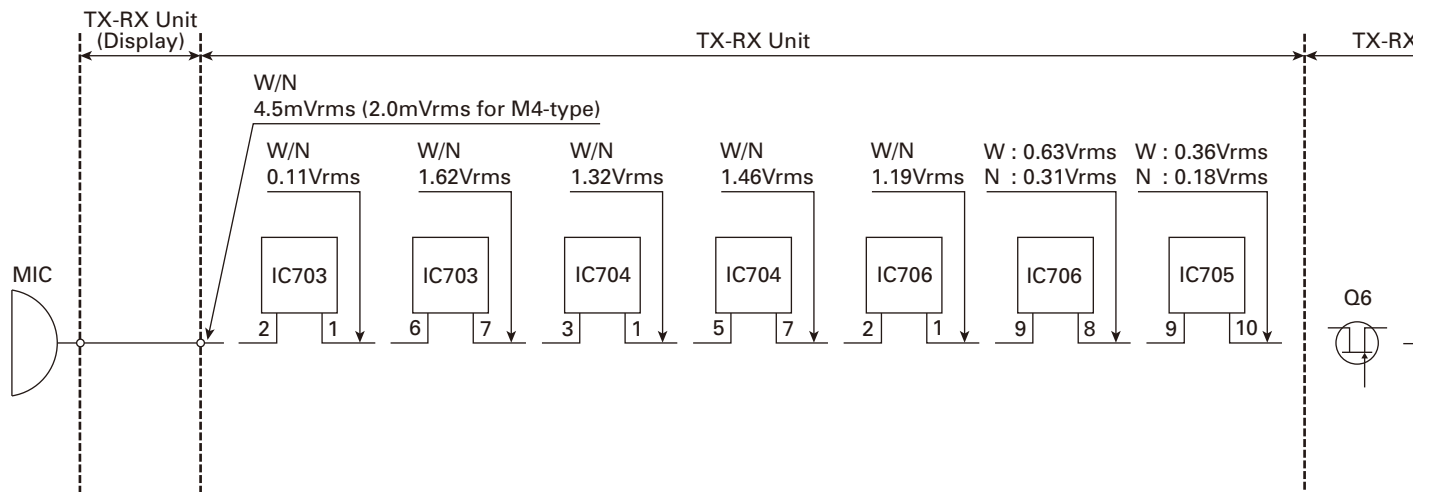

To make measurements in the AF section, connect the AC level meter. AG is set so that MIC input becomes 3kHz/1.5kHz (Wide/Narrow) DEV at 1kHz MOD.

To make

LEVEL DIAGRAM

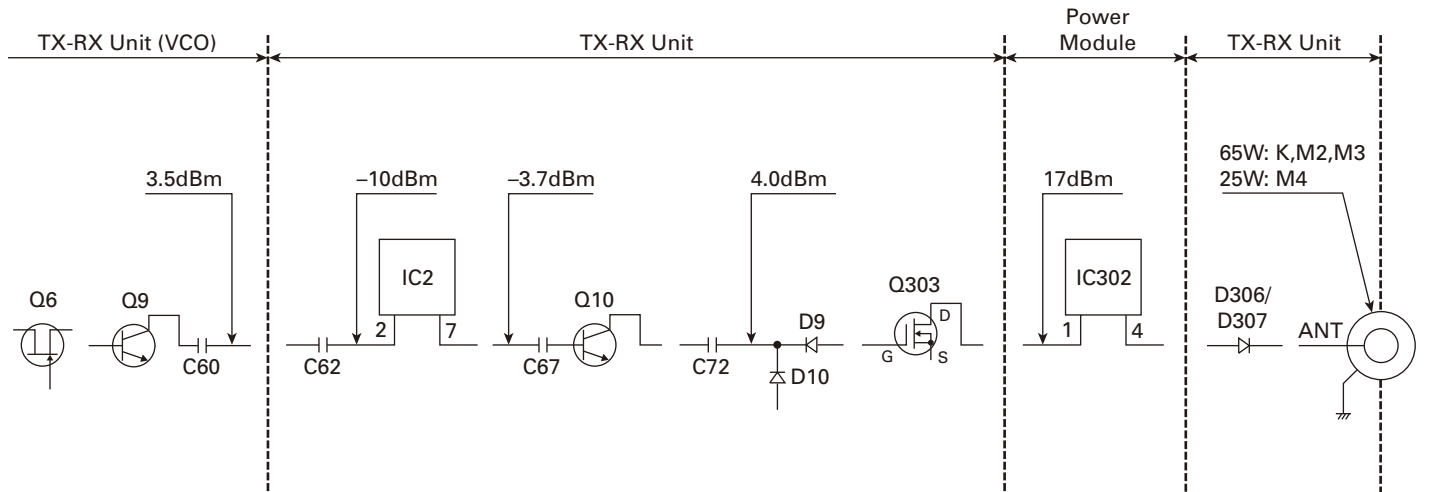
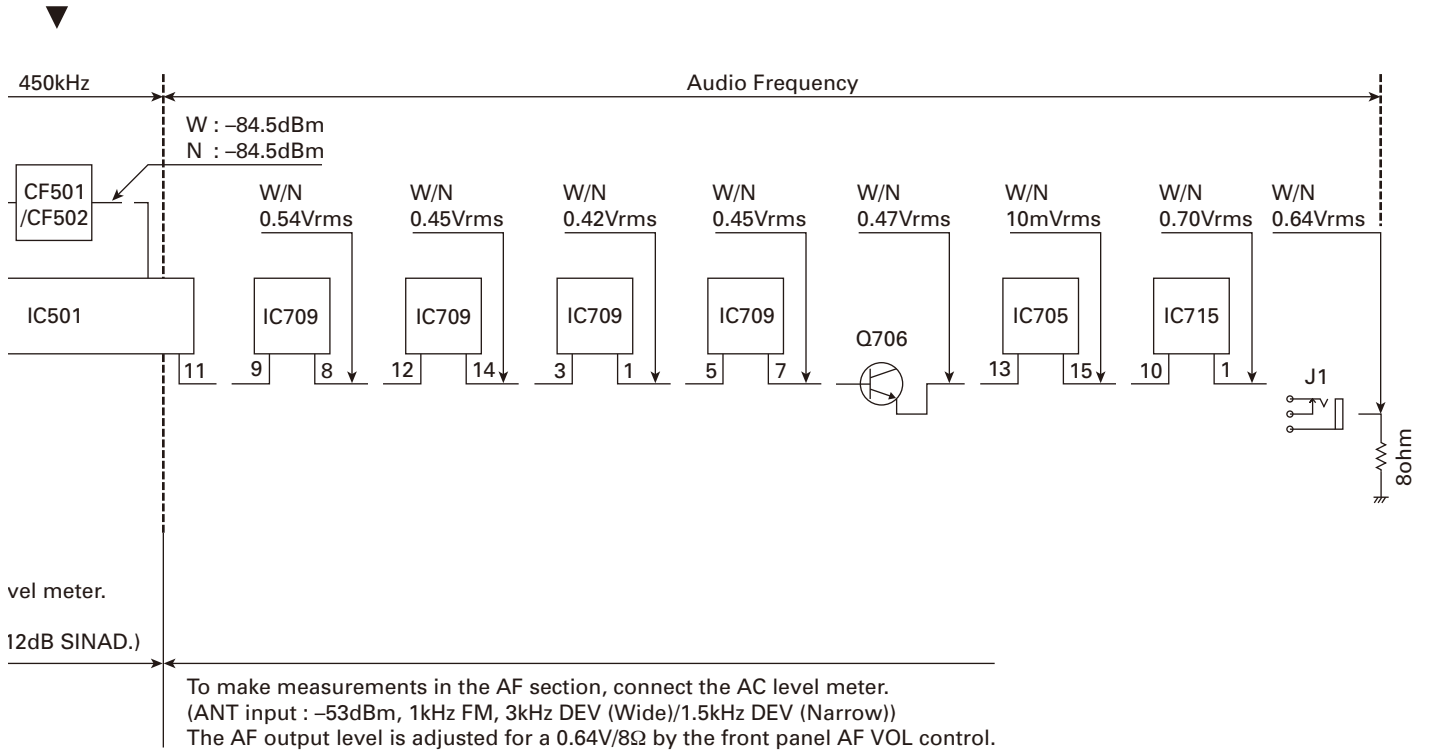

To make measurements in the RF section, connect the RF Wattmeter (50Ω).



SPECIFICATIONS

GENERAL

Frequency Range		
TX.....	K,M4: 144~148MHz	M2,M3: 136~174MHz
RX.....	K,M2,M3: 136~174MHz	M4: 144~148MHz
Mode.....	F3E (FM)	
Antenna Impedance.....	50Ω	
Usable Temperature Range.....	-20°C~+60°C (-4°F~+140°F)	
Power Supply.....	13.8V DC±15% (11.7~15.8V)	
Grounding Method.....	Negative ground	
Current		
Transmit (max.).....	K,M2,M3: 14A or less	M4: 8A or less
Receive (at 2W output).....	1.0A or less	
Frequency Stability (-20°C~+60°C).....	Within ±2.5ppm	
Dimensions (W x H x D projections not included).....	160 x 43 x 126 mm / 6.30 x 1.69 x 4.69 in	
Weight.....	Approx. 1.13kg / 2.5lb	

RECEIVER

Circuitry.....	Double conversion superheterodyne	
Intermediate Frequency (1st / 2nd).....	49.95MHz / 450kHz	
Sensitivity (12dB SINAD).....	Wide: 0.18μV or less	Narrow: 0.22μV or less
Selectivity		
-6dB.....	Wide: 12kHz or more	Narrow: 10kHz or more
-60dB.....	Wide: 30kHz or less	Narrow: 24kHz or less
Squelch Sensitivity.....	0.1μV or less	
Audio Output (8Ω, 5% distortion).....	2W or higher	
Audio Output Impedance.....	8Ω	

TRANSMITTER

Power Output		
High.....	K,M2,M3: 65W	M4: 25W
Low.....	K,M2,M3: Approx. 25W	
Modulation.....	Variable reactance modulation	
Spurious Emissions.....	-60dB or less	
Maximum Frequency Deviation.....	Wide: ±5kHz	Narrow: ±2.5kHz
Audio Distortion (at 60% modulation).....	3% or less	
Microphone Impedance.....	600Ω	

Note: All specifications (General, Transmitter and Receiver) are guaranteed within the amateur radio band.

Guaranteed frequency range..... 144~148MHz

Kenwood Corporation

2967-3, Ishikawa-machi, Hachioji-shi, Tokyo, 192-8525 Japan

Kenwood U.S.A. Corporation

P.O. BOX 22745, 2201 East Dominguez Street, Long Beach, CA 90801-5745, U.S.A.

Kenwood Electronics Canada Inc.

6070 Kestrel Road, Mississauga, Ontario, Canada L5T 1S8

Kenwood Electronics Deutschland GmbH

Rembrücker Str. 15, 63150 Heusenstamm, Germany

Kenwood Electronics Belgium N.V.

Leuvensesteenweg 248 J, 1800 Vilvoorde, Belgium

Kenwood Electronics France S.A.

L'Etoile Paris Nord 2, 50 Allée des Impressionnistes, Bp 58416 Villepinte, 95944 Roissy Ch De Gaulle Cedex

Kenwood Electronics UK Limited

KENWOOD House, Dwight Road, Watford, Herts., WD18 9EB United Kingdom

Kenwood Electronics Europe B.V.

Amsterdamseweg 37, 1422 AC Uithoorn, The Netherlands

Kenwood Electronics Italia S.p.A.

Via G. Sirtori, 7/9 20129 Milano, Italy

Kenwood Ibérica, S.A.

Carretera de Rubi, 88 Planta 1 A 08174 Sant Cugat del Vallès Barcelona, Spain

Kenwood Electronics Australia Pty. Ltd.

Talavera Business Park Building A, 4 Talavera Road, North Ryde NSW 2113 Australia

Kenwood Electronics (Hong Kong) Ltd.

Suite 2504, 25/F, Tower 2, Nina Tower, No. 8 Yeung Uk Road, Tsuen Wan, New Territories, Hong Kong

Kenwood Electronics Singapore Pte Ltd

1 Ang Mo Kio Street 63, Singapore 569110

TM-281A PC BOARD

PC BOARD TM-281A

TX-RX UNIT (X57-8130-XX) (A/2): TX-RX SECTION
-10: K -21: M2 -22: M3 -23: M4
Component side view (J79-0316-09 A/2)

TX-RX UNIT (X57-8130-XX) (A/2): TX-RX SECTION
-10: K -21: M2 -22: M3 -23: M4
Component side view (J79-0316-09 A/2)

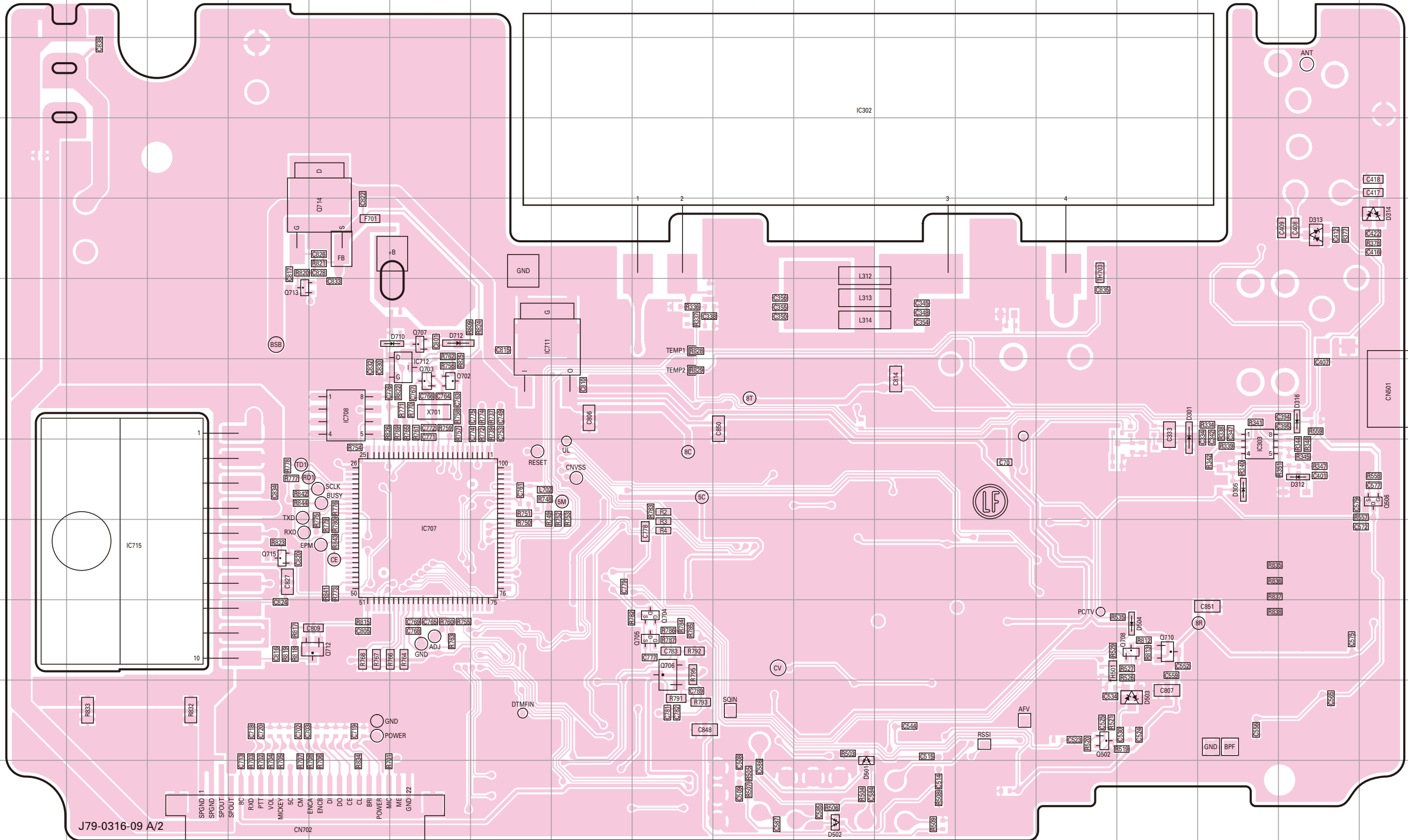

Ref. No.	Address
IC302	3K
IC303	8P
IC707	9F
IC708	7E
IC711	6G
IC712	7F
IC715	9B
Q502	11N
Q506	8R
Q702	7F
Q703	7F
Q704	10I
Q705	10I
Q706	10I
Q707	6F
Q708	100
Q710	100
Q712	10E
Q713	6D
Q714	5E
Q715	9D
D301	7O
D305	8P
D312	8Q
D313	5Q
D314	5R
D316	7Q
D501	12K
D502	12K
D503	11O
D510	100
D710	6F
D712	6F

J79-0316-09 A/2

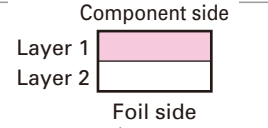
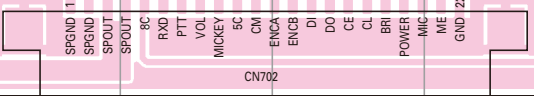

TM-281A PC BOARD

PC BOARD TM-281A

TX-RX UNIT (X57-8130-XX) (B/2): DISPLAY SECTION
-10: K -21: M2 -22: M3 -23: M4
Component side view (J79-0316-09 B/2)

TX-RX UNIT (X57-8130-XX) (B/2): DISPLAY SECTION
-10: K -21: M2 -22: M3 -23: M4
Component side view (J79-0316-09 B/2)

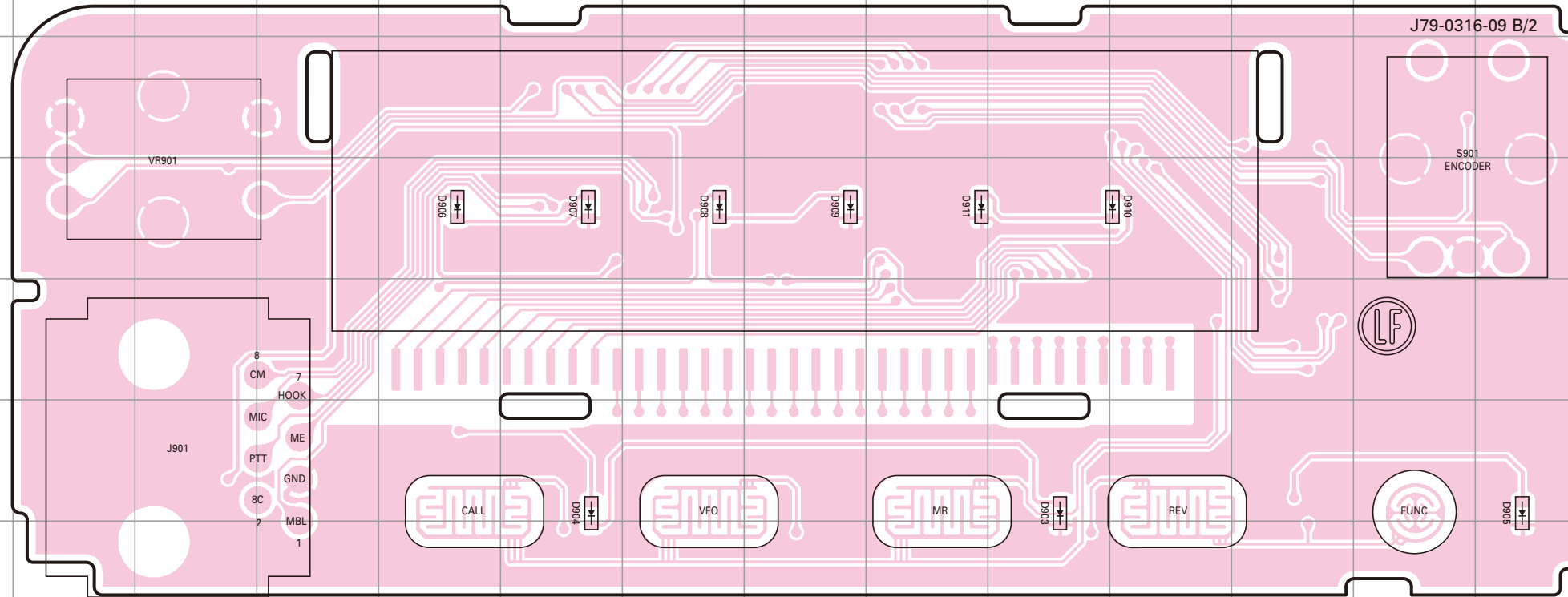

Ref. No.	Address
D903	6K
D904	6G
D905	6O
D906	4F
D907	4G
D908	4H
D909	4I
D910	4L
D911	4J

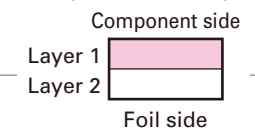

TX-RX UNIT (X57-8130-XX) (B/2): DISPLAY SECTION
-10: K -21: M2 -22: M3 -23: M4
Foil side view (J79-0316-09 B/2)

TX-RX UNIT (X57-8130-XX) (B/2): DISPLAY SECTION
-10: K -21: M2 -22: M3 -23: M4
Foil side view (J79-0316-09 B/2)

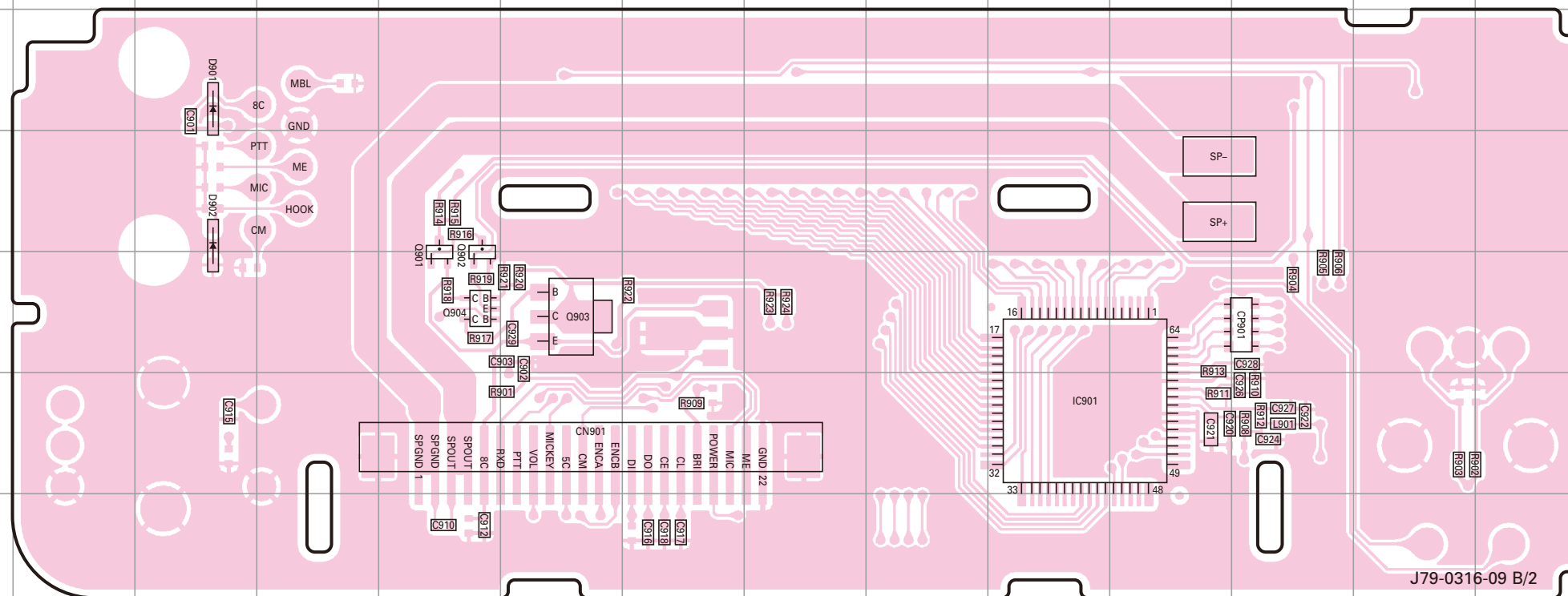

Ref. No.	Address
IC901	12K
Q901	11F
Q902	11F
Q903	11G
Q904	11F
D901	9D
D902	10D

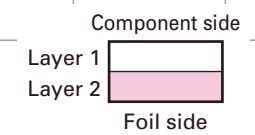

TX-RX UNIT (X57-8130-XX B/2): Display section

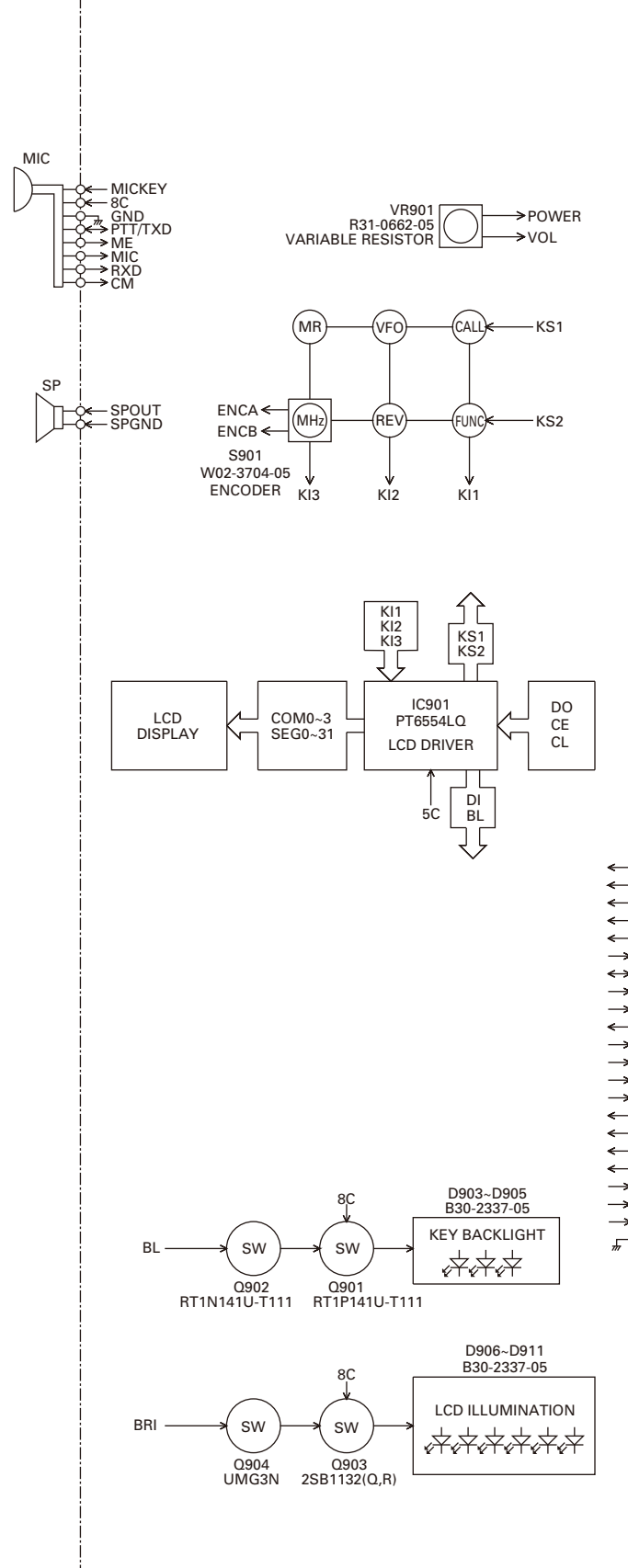

TX-RX UNIT (X57-8130-XX A/2): TX-RX section

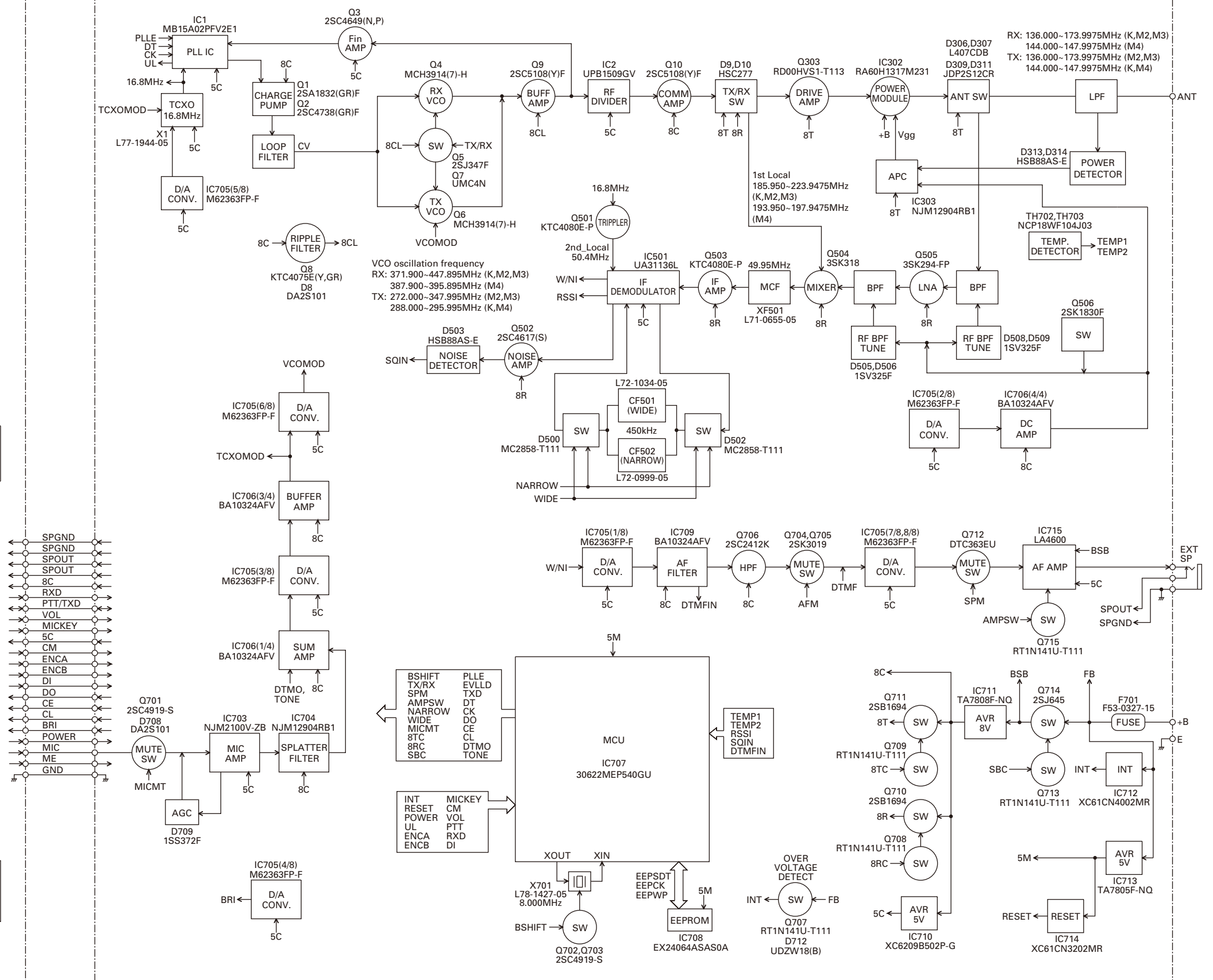

Receiver Section

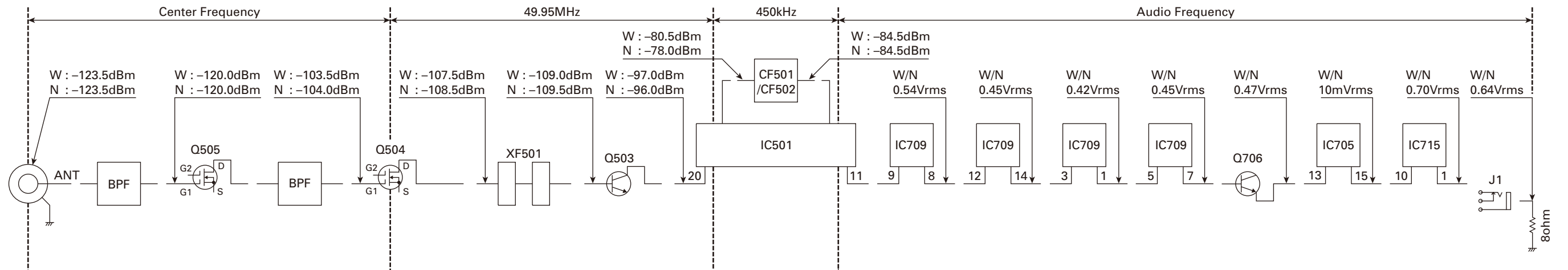

To make measurements in the RF section, connect the RF level meter.
In the RF section, use a 0.01 μ F coupling capacitor.
(The display shows the SSG input value required to obtain 12dB SINAD.)

To make measurements in the AF section, connect the AC level meter.
(ANT input : -53dBm, 1kHz FM, 3kHz DEV (Wide)/1.5kHz DEV (Narrow))
The AF output level is adjusted for a 0.64V/8 Ω by the front panel AF VOL control.

Transmitter Section

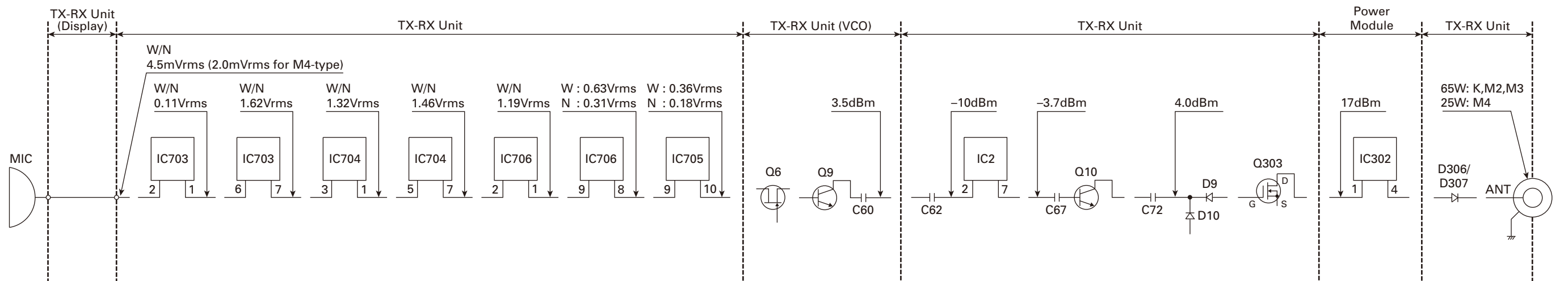

To make measurements in the AF section, connect the AC level meter.
AG is set so that MIC input becomes 3kHz/1.5kHz (Wide/Narrow) DEV at 1kHz MOD.

To make measurements in the RF section, connect the RF Wattmeter (50 Ω).