

## IMPORTANT WARRANTY INFORMATION! PLEASE READ

**Return Policy on Kits When *Not* Purchased Directly From Vectronics:** Before continuing any further with your VEC kit check with your Dealer about their return policy. If your Dealer allows returns, your kit must be returned *before* you begin construction.

**Return Policy on Kits When Purchased Directly From Vectronics:** Your VEC kit may be returned to the factory *in its pre-assembled condition only*. The reason for this stipulation is, once you begin installing and soldering parts, you essentially take over the role of the device's manufacturer. From this point on, neither Vectronics nor its dealers can reasonably be held accountable for the quality or the outcome of your work. Because of this, Vectronics cannot accept return of any kit-in-progress or completed work as a warranty item for any reason whatsoever. If you are a new or inexperienced kit builder, we urge you to read the manual carefully and determine whether or not you're ready to take on the job. If you wish to change your mind and return your kit, you may--but you must do it *before* you begin construction, and within ten (10) working days of the time it arrives.

**Vectronics Warrants:** Your kit contains each item specified in the parts list.

**Missing Parts:** If you determine, during your pre-construction inventory, that any part is missing, please contact Vectronics and we'll send the missing item to you free of charge. However, *before* you contact Vectronics, *please look carefully* to confirm you haven't misread the marking on one of the other items provided with the kit. Also, make certain an alternative part hasn't been substituted for the item you're missing. If a specific part is no longer available, or if Engineering has determined that an alternative component is more suitable, Vectronics reserves the right to make substitutions at any time. In most cases, these changes will be clearly noted in an addendum to the manual.

**Defective Parts:** Today's electronic parts are physically and electrically resilient, and defective components are rare. However, if you discover an item during your pre-construction inventory that's obviously broken or unserviceable, we'll replace it. Just return the part to Vectronics at the address below accompanied with an explanation. Upon receipt, we'll test it. If it's defective and appears unused, we'll ship you a new one right away at no charge.

**Missing or Defective Parts After You Begin Assembly:** Parts and materials lost or damaged *after construction begins* are not covered under the terms of this warranty. However, most parts supplied with VEC kits are relatively inexpensive and Vectronics can replace them for a reasonable charge. Simply contact the factory with a complete description. We'll process your order quickly and get you back on track.

**Factory Repair After You Begin Assembly:** *Kits-in progress and completed kits are specifically excluded from coverage by the Vectronics warranty.* However, as a service to customers, technicians are available to evaluate and repair malfunctioning kits for a minimum service fee of \$18.00 (½ hour rate) plus \$7.00 shipping and handling (prices subject to change). To qualify for repair service, your kit must be fully completed, unmodified, and the printed circuit board assembled using rosin-core solder. In the event your repair will require more than an hour to fix (or \$36.00, subject to change), our technicians will contact you in advance by telephone before performing the work. Defective units should be shipped prepaid to:

Vectronics  
1007 HWY 25 South  
Starkville, MS 39759

When shipping, pack your kit well and include the minimum payment plus shipping and handling charges (\$25.00 total). No work can be performed without pre-payment. Also, provide a valid UPS return address and a day time phone number where you may be reached.

## **INTRODUCTION**

Quickly and safely charge all types of NiCad or NiMH batteries; including cell phones, camcorders, lap-top computers, hand-held radios—many in less than an hour! Vectronics' exclusive **RapidBattery™** technology determines when your batteries are fully charged and its top-off feature keeps batteries at full-charge, without overcharging. Simple wall-chargers can fry expensive battery packs if used for weeks at a time. You set how many cells are to be charged, what charge rate to use and for how long, and the discharge rate. The smart integrated circuit chip then takes control—it senses the correct points for discharge and full-charge. After a full charge, the charger automatically keeps the battery at peak capacity with a periodic top-off charge.

NiCads can develop a memory effect making your batteries appear to be nearly dead or to have a shortened life. Vectronics's *discharge-before-charge feature* can recondition NiCads to near new operation by first fully discharging the cells, and then fully recharging the cells. After a few cycles, the memory effect will be reversed, making your expensive battery packs work like new!

Extend your battery's useful life. Save valuable time with the Vectronics **RapidBattery™** charger kit. No more waiting hours for poky trickle chargers, and an end to wasting your hard earned dough on new battery packs.

## **TOOLS AND SUPPLIES**

**Construction Area:** Kit construction requires a clean, smooth, and well-lighted area where you can easily organize and handle small parts without losing them. An inexpensive sheet of white poster board makes an excellent construction surface, while providing protection for the underlying table or desk. Well-diffused overhead lighting is a plus, and a supplemental high-intensity desk lamp will prove especially helpful for close-up work. Safety is an important consideration. Be sure to use a suitable high-temperature stand for your soldering iron, and keep the work area free of combustible clutter.

**Universal Kit-building Tools:** Although your particular kit may require additional items to complete, virtually all construction projects require a work area outfitted with the following tools and supplies:

- 30 to 60 Watt Soldering Iron
- High-temperature Iron Holder with Moist Cleaning Sponge
- Rosin-core Solder (thin wire-size preferred)
- Needle Nose Pliers or Surgical Hemostats
- Diagonal Cutters or "Nippy Cutters"

- Solder Sucker, Vacuum Pump, or Desoldering Braid
- Bright Desk Lamp
- Magnifying Glass
- Phillips screw driver

## **BEFORE YOU START BUILDING**

Experience shows there are *four common mistakes* builders make. Avoid these, and your kit will probably work on the first try! Here's what they are:

- 1. Installing the Wrong Part:** It always pays to double-check each step. A 1K and a 10K resistor may look *almost* the same, but they may act very differently in an electronic circuit! Same for capacitors--a device marked 102 (or .001 uF) may have very different operating characteristics from one marked 103 (or .01uF).
- 2. Installing Parts Backwards:** Always check the polarity of electrolytic capacitors to make sure the positive (+) lead goes in the (+) hole on the circuit board. Transistors have a flat side or emitter tab to help you identify the correct mounting position. ICs have a notch or dot at one end indicating the correct direction of insertion. Diodes have a banded end indicating correct polarity. Always double-check--especially before applying power to the circuit!
- 3. Faulty Solder Connections:** Inspect for cold solder joints and solder bridges. Cold solder joints happen when you don't fully heat the connection--or when metallic corrosion and oxide contaminate a component lead or pad. Solder bridges form when a trail of excess solder shorts pads or tracks together (see Solder Tips below).
- 4. Omitting or Misreading a Part:** This is easier to do than you might think! Always double-check to make sure you completed each step in an assembly sequence.

**Soldering Tips:** *Cleanliness* and good *heat distribution* are the two secrets of professional soldering. Before you install and solder each part, inspect leads or pins for oxidation. If the metal surface is dull, sand with fine emery paper until shiny. Also, clean the oxidation and excess solder from the soldering iron tip to ensure maximum heat transfer. Allow the tip of your iron to contact both the lead and pad for about one second (count "one-thousand-one") before feeding solder to the connection. Surfaces must become hot enough for solder to *flow smoothly*. Feed solder to the opposite side of the lead from your iron tip--solder will wick around the lead toward the tip, wetting all exposed surfaces. Apply

solder sparingly, and do not touch solder directly to the hot iron tip to promote rapid melting.

**Desoldering Tips:** If you make a mistake and need to remove a part, follow these instructions carefully! First, grasp the component with a pair of hemostats or needle-nose pliers. Heat the pad beneath the lead you intend to extract, and pull gently. The lead should come out. Repeat for the other lead. Solder may fill in behind the lead as you extract it--especially if you are working on a double-sided board with plate-through holes. Should this happen, try heating the pad again and inserting a common pin into the hole. Solder won't stick to the pin's chromium plating. When the pad cools, remove the pin and insert the correct component. For ICs or multi-pin parts, use desoldering braid to remove excess solder before attempting to extract the part. Alternatively, a low-cost vacuum-bulb or spring-loaded solder sucker may be used. Parts damaged or severely overheated during extraction should be replaced rather than reinstalled.

**Work Habits:** Kit construction requires the ability to follow detailed instructions and, in many cases, to perform new and unfamiliar tasks. To avoid making needless mistakes, work for short periods when you're fresh and alert. Recreational construction projects are more informative and more fun when you take your time. Enjoy!

**Sorting and Reading Resistors:** The electrical value of resistors is indicated by a color code (shown below). You don't have to memorize this code to work with resistors, but you do need to understand how it works:

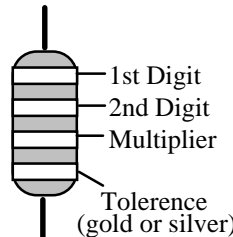
<b>Resistor Color Code</b>		
	Black = 0 (tens)	Blue = 6
	Brown = 1 (hundreds)	Violet = 7
	Red = 2 (K)	Gray = 8
	Orange = 3 (10K)	White = 9
	Yellow = 4 (100K)	Silver = 10%
	Green = 5 (1Meg)	Gold = 5%

When you look at a resistor, check its multiplier code first. Any resistor with a black multiplier band falls between 10 and 99 ohms in value. Brown designates a value between 100 and 999 ohms. Red indicates a value from 1000 to 9999 ohms, which is also expressed as 1.0K to 9.9K. An orange multiplier band designates 10K to 99K, etc. To sort and inventory resistors, first separate them into groups by multiplier band (make a pile of 10s, 100s, Ks, 10Ks, etc.). Next, sort each group by specific value (1K, 2.2K, 4.7K, etc.). This procedure makes the inventory easier, and also makes locating specific parts more convenient later.

on during construction. Some builders find it especially helpful to arrange resistors in ascending order along a strip of double-sided tape.

Some VEC kits may contain molded chokes which appear, at first glance, similar to resistors in both shape and band marking. However, a closer look will enable you to differentiate between the two--chokes are generally larger in diameter and fatter at the ends than resistors. When doing your inventory, separate out any chokes and consult the parts list for specific color-code information.

**Reading Capacitors:** Unlike resistors, capacitors no longer use a color code for value identification. Instead, the value, or a 3-number code, is printed on the body.

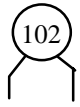
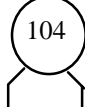
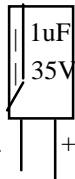
Value	Code				
10 pF	= 100				
100 pF	= 101				
1000 pF	= 102				
.001 uF	= 102*				
.01 uF	= 103				
.1 uF	= 104				
		Multilayer (270 pF)	Ceramic Discs (.001 uF)    (.1 uF)		Electrolytic 1 uF
					

As with resistors, it's helpful to sort capacitors by type, and then to arrange them in ascending order of value. Small-value capacitors are characterized in pF (or pico-Farads), while larger values are labeled in uF (or micro-Farads). The transition from pF to uF occurs at 1000 pF (or .001 uF)\*. Today, most monolithic and disc-ceramic capacitors are marked with a three-number code. The first two digits indicate a numerical value, while the last digit indicates a multiplier (same as resistors).

Electrolytic capacitors are always marked in uF. Electrolytics are polarized devices and must be oriented correctly during installation. If you become confused by markings on the case, remember the uncut negative lead is slightly shorter than the positive lead.

**Diodes:** Diodes are also polarized devices that must be installed correctly. Always look for the banded or cathode end when installing, and follow instructions carefully.

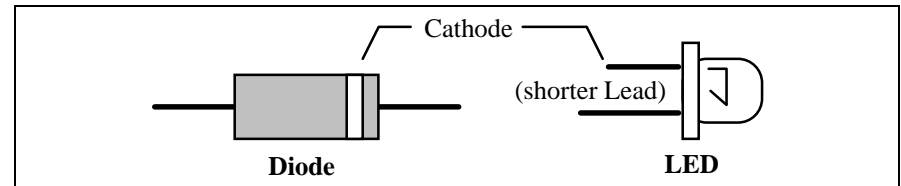

**Transistors:** If transistors are installed incorrectly, damage may result when power is applied. Transistors in metal cases have a small tab near the emitter lead to identify correct positioning. Semiconductors housed in small plastic cases (TO-92) have an easily-identified flat side to identify mounting orientation. Many specialized diodes and low-current voltage regulators also use this type packaging. Larger plastic transistors and voltage regulators use a case backed with a prominent metal tab to dissipate heat (T-220). Here orientation is indicated by the positioning of the cooling tab.

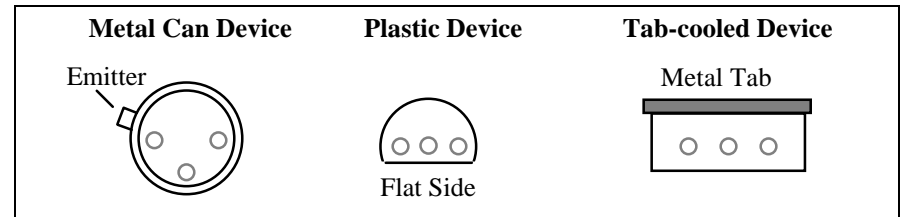

**Integrated Circuits:** Proper IC positioning is indicated by a dot or square marking located on one end of the device. A corresponding mark will be silk-screened on the PC board and printed on the kit's parts-placement diagram. To identify specific IC pin numbers for testing purposes, see the diagram below. Pin numbers always start at the keyed end of the case and progress counter-clockwise around the device, as shown:

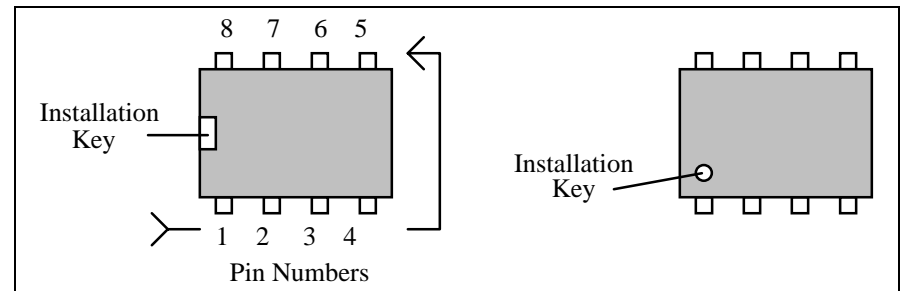

## **PARTS LIST**

Your package kit should contain all of the parts listed below. Please go through the parts bag to identify and inventory each item on the checklist before you start building. If any parts are missing or damaged, refer to the warranty section of this manual for replacement instructions. If you can't positively identify an unfamiliar item in the bag on the basis of the information given, set it aside until

all other items are checked off. You may then be able to identify it by process of elimination. Finally, your kit will go together more smoothly if parts are organized by type and arranged by value ahead of time. Use this inventory as an opportunity to sort and arrange parts so you can identify and find them quickly.

**Note:** Ignore the fourth color band when reading resistors, it denotes the tolerance value and is not needed for parts inventory or assembly directions.

**Resistors:**

<input checked="" type="checkbox"/>	Qty	Part Description	Designation
<input type="checkbox"/>	6	1.5-ohm 1/4 Watt (brown-green-gold)	R16,R22,R23,R24,R25, R26
<input type="checkbox"/>	2	18-ohm 1/2 Watt (brown-gray-black)	R21,R28
<input type="checkbox"/>	1	220-ohm 1/4 Watt (red-red-brown)	R1
<input type="checkbox"/>	1	820-ohm 2 Watt (gray-red-brown)	R20
<input type="checkbox"/>	3	1K-ohm 1/4 Watt (brown-black-red)	R3,R12,R17
<input type="checkbox"/>	1	27K-ohm 1/4Watt (red-violet-orange)	R5
<input type="checkbox"/>	11	47K-ohm 1/4Watt (yellow-violet-orange)	R2,R4,R6,R7,R8,R9,R10, R11,R14,R15,R18
<input type="checkbox"/>	2	100K-ohm 1/4 Watt (brown-black-yellow)	R19,R27
<input type="checkbox"/>	1	270K-ohm 1/4 Watt (red-violet-yellow)	R13

**Capacitors:**

<input checked="" type="checkbox"/>	Qty	Part Description	Designation
<input type="checkbox"/>	5	.1-uF disc ceramic (104 or .1)	C3,C4,C5,C6,C7
<input type="checkbox"/>	2	100-uF electrolytic	C1,C2

**Inductors:**

<input checked="" type="checkbox"/>	Qty	Part Description	Designation
<input type="checkbox"/>	1	500-uH choke	L1

**Semiconductors:**

<input checked="" type="checkbox"/>	Qty	Part Description	Designation
<input type="checkbox"/>	2	1N4001, diode rectifier	D1,D4



<input type="checkbox"/>	1	1N5822, diode Schottky	D2
<input type="checkbox"/>	1	1N5223B, 2.7 volt zener diode	D3
<input type="checkbox"/>	1	2N3055, power transistor (TO-3)	Q1
<input type="checkbox"/>	1	2N3904, transistor	Q2
<input type="checkbox"/>	1	IRF9530, power FET	Q3
<input type="checkbox"/>	1	BQ2003 IC (16-pin DIP package)	U1
<input type="checkbox"/>	1	78L05, +5Vdc voltage regulator	U2
<input type="checkbox"/>	1	LED, red	CR1
<input type="checkbox"/>	1	LED, yellow	CR2

**Switches/Jacks/Misc.:**

<input checked="" type="checkbox"/>	Qty	Part Description	Designation
<input type="checkbox"/>	1	2.1mm coaxial power jack	J1
<input type="checkbox"/>	1	Rotary switch 2 pole, 6 position	SW1
<input type="checkbox"/>	3	DPDT push-action switches	SW2,SW3,SW4
<input type="checkbox"/>	1	16-pin IC socket	For U1
<input type="checkbox"/>	6	3 position header	HD1,HD2,HD3,HD4,HD5, HD6
<input type="checkbox"/>	6	2 position shorting jumper	
<input type="checkbox"/>	1	20 AWG red-black cable	
<input type="checkbox"/>	3	4-40 phillips x 1/4" screw	
<input type="checkbox"/>	3	4-40 phillips hex nut	
<input type="checkbox"/>	1	PC board for VEC-412K	
<input type="checkbox"/>	1	VEC-412K Owner's Manual	

### PARTS PLACEMENT DIAGRAM

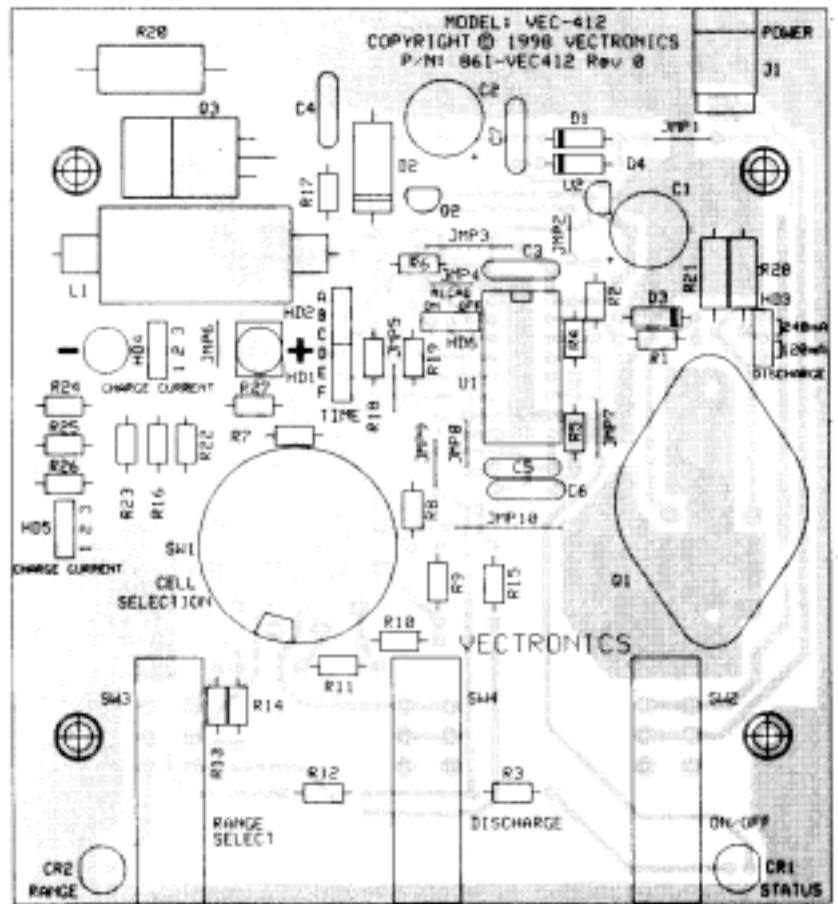

## **STEP-BY-STEP ASSEMBLY**

Before assembling your kit, please take time to read and understand the VEC kit warranty printed on the inside cover of this manual. Also, read through the assembly instructions to make sure the kit does not exceed your skill level. Once you begin construction, your kit will be non-returnable. Finally, if you haven't already done so, please verify that all parts listed in the inventory are included. If anything is missing or broken, refer to the warranty instructions for replacing missing or damaged parts.

Note that part designators, such as R1, C3, etc., appear on a silk-screened legend on the component-mounting side of the printed circuit board. This corresponds with the parts placement page in the manual. All parts will be inserted on the silk-screen side of the board.

If you have last-minute questions about tools and materials needed to build your kit, please refer back to the section titled "Before You Start Building". If you're ready to begin now, let's get started! The directions use two sets of check boxes. Check one when a step is complete and use the other for double-checking your work before operation.

**“Install”** When you are directed to *install* a part, this means to locate, identify, and insert the part into its mounting holes on the PC board. This includes pre-bending or straightening leads as needed so force is not required to seat the part. Once a component is mounted, bend each lead over to hold it in place. Make sure trimmed leads don't touch other pads and tracks, or a short circuit may result:



**“Solder”** When you are directed to *solder*, this means to solder the part's leads in place, and to inspect both (or all) solder connections for flaws or solder bridges. If no soldering problems are noted, nip off the excess protruding leads with a sharp pair of side cutters.

Notice that the directions use two check boxes. Check one when a step is complete and use the other for double-checking your work before operation.

### **¼-Watt Resistor Installation:**

You will begin assembly by installing the  $\frac{1}{4}$ -watt fixed resistors. Because these are all 5-percent tolerance ending with a fourth *gold* color band, you need only read the first three bands of the color code during the following steps. All resistor leads should be formed as shown below.

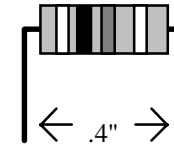

**Note:** The fourth resistor color band is for tolerance, and is not called out in the following steps.

Begin by finding the six 1.5-ohm resistors (brown-green-gold-gold). Install and solder at the following locations:

- 1. R16 1.5-ohm resistor (brown-green-gold)
- 2. R22 1.5-ohm resistor (brown-green-gold)
- 3. R23 1.5-ohm resistor (brown-green-gold)
- 4. R24 1.5-ohm resistor (brown-green-gold)
- 5. R25 1.5-ohm resistor (brown-green-gold)
- 6. R26 1.5-ohm resistor (brown-green-gold)
- 7. Locate the 220-ohm resistor (red-red-brown). Install and solder at location R1.

Locate the three 1,000-ohm (1K-ohm) resistors (brown-black-red). Install and solder at the following locations:

- 8. R3 1K-ohm (brown-black-red)
- 9. R12 1K-ohm (brown-black-red)
- 10. R17 1K-ohm (brown-black-red)
- 11. Locate the 27,000-ohm (27K-ohm) resistor (red-violet-orange). Install and solder at location R5.

Locate the eleven 47,000 ohm (47K-ohm) resistors (yellow-violet-orange). Install and solder at the following locations:

- 12. R2 47K-ohm (yellow-violet-orange)
- 13. R4 47K-ohm (yellow-violet-orange)
- 14. R6 47K-ohm (yellow-violet-orange)

- 15. R7 47K-ohm (yellow-violet-orange)
- 16. R8 47K-ohm (yellow-violet-orange)
- 17. R9 47K-ohm (yellow-violet-orange)
- 18. R10 47K-ohm (yellow-violet-orange)
- 19. R11 47K-ohm (yellow-violet-orange)
- 20. R14 47K-ohm (yellow-violet-orange)
- 21. R15 47K-ohm (yellow-violet-orange)
- 22. R18 47K-ohm (yellow-violet-orange)

Locate the two 100,000-ohm (100K-ohm) resistors (brown-black-yellow). Install and solder at the following locations:

- 23. R19 100K-ohm (brown-black-yellow)
- 24. R27 100K-ohm (brown-black-yellow)
- 25. Locate the 270,000-ohm (270K-ohm) resistor (red-violet-yellow). Install and solder at location R13.

Save the ¼-watt resistor lead clippings for the next phase of assembly.

#### **Installing of Larger-Wattage Resistors:**

Locate the two 18-ohm ½-watt resistors (brown-gray-black). Install and solder at the following locations:

- 1. 18-ohm resistor (brown-gray-black) at R21.
- 2. 18-ohm resistor (brown-gray-black) at R28.
- 3. Locate the 820-ohm 2-watt resistor (gray-red-brown). This resistor's body is much larger than the ¼-watt styles. Install and solder at location R20.

This completes the resistor installation. There should be no resistors left in the kit. Go back over each solder connection, and verify that all resistor are in the correct locations. Recheck each solder joint for bridges, and redo any suspect solder connections.

#### **Installation of Wire Jumpers:**

Use scrap resistor lead ends for use as jumper wires, as shown in the following diagram. Use needle-nose pliers to form each one to fit properly at each location, making sure each rests flat on the PC board when installed:

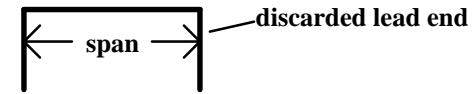

Install and solder wire jumpers at the following locations:

- 1. JMP1 jumper wire
- 2. JMP2 jumper wire
- 3. JMP3 jumper wire
- 4. JMP4 jumper wire
- 5. JMP5 jumper wire
- 6. JMP6 jumper wire
- 7. JMP7 jumper wire
- 8. JMP8 jumper wire
- 9. JMP9 jumper wire
- 10. JMP10 jumper wire

#### **Capacitor Installation:**

Locate the five .1-uF ceramic disc capacitors (104 or .1). Install and solder at the following locations:

- 1. C3 .1-uF ceramic disc capacitor (104 or .1)
- 2. C4 .1-uF ceramic disc capacitor (104 or .1)
- 3. C5 .1-uF ceramic disc capacitor (104 or .1)
- 4. C6 .1-uF ceramic disc capacitor (104 or .1)
- 5. C7 .1-uF ceramic disc capacitor (104 or .1)

Locate the two 100-uF electrolytic capacitors. Note that these are polarized devices—they must be installed with regard to lead polarity! Carefully observe the polarity markings on the board silk-screen, and the pictorial diagram before soldering! Install and solder at the following locations:

- 6. C1 100-uF electrolytic capacitor. Observe polarity!
- 7. C2 100-uF electrolytic capacitor. Observe polarity!

This completes installation of the capacitors. Recheck all work done so far and correct any misplaced components or bad solder joints.

#### Header Installation:

Locate the six 3-position headers. Install and solder at the following locations:

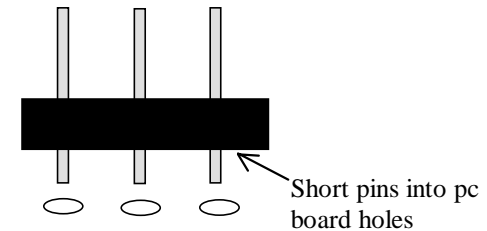

- 1. HD1 Three-position header
- 2. HD2 Three-position header
- 3. HD3 Three-position header
- 4. HD4 Three-position header
- 5. HD5 Three-position header
- 6. HD6 Three-position header

#### Semiconductor Installation:

**Note:** All semiconductors are polarized devices. They must be installed as directed. Use the pictorial drawing and the silk-screened legend on the pc board to verify proper installation of these devices!

Locate the two 1N4001 silicon rectifier diodes. Install and solder at the following locations—observe the orientation of the cathode lead:



- 1. D1 1N4001 diode, observe polarity!
- 2. D4 1N4001 diode, observe polarity!

- 3. Locate the 1N5822 diode (largest bodied diode in kit). While observing cathode lead orientation, insert and solder at location D2.
- 4. Locate the 1N5223B diode. While observing cathode lead orientation, insert and solder at location D3.

Locate the RED LED. Observe that the cathode lead is the shorter of the two device leads. The cathode lead is also indicated by a small flat area in the otherwise round base of the device.

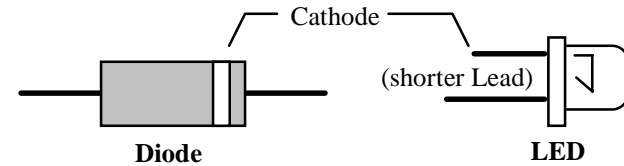

- 5. Install the RED LED at location CR1 on the PC board. Verify that the body outline corresponds to the PC board legend and pictorial diagram. Install the LED leads until the shouldered stops on the leads are flush to the PC board. Bend the leads so the LED is flush with the edge of the PC board. Solder.
- 6. Locate the YELLOW LED . Install and solder at location CR2 on the PC board. Observe polarity.
- 7. Locate the 2N3904 transistor. Install and solder at location Q2. Note the device has a rounded and flat side. Observe proper orientation using the PC board legend and pictorial diagram.

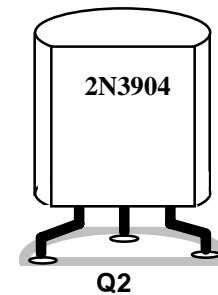

- 8. Locate the 78L05 three-terminal voltage regulator IC. Observing polarity, install and solder at location U2.



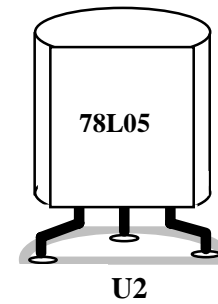

Locate the 16-pin DIP IC socket. Notice that the socket is “keyed” to show proper pin orientation.

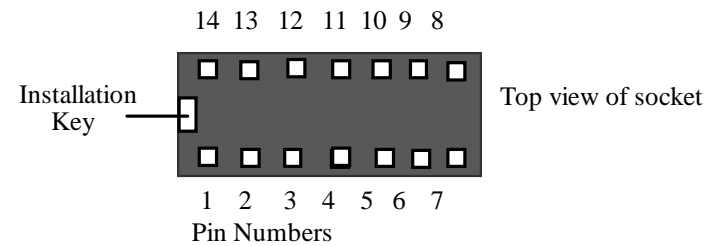

- □ 9. Install and solder the 14-pin IC socket at location U1. Observe that the key aligns with the legend outline on the pc board.

Locate the BQ2003 IC (14-pin DIP package).

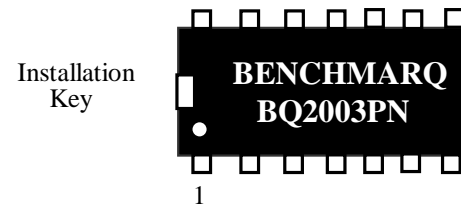

The IC body has a small notch, or *key*, molded at one end, indicating pins 1 and 14. A small dimple-like body-molding is often found adjacent to pin 1. Some IC packages may include both key indicators.

- □ 10. Align the key on the IC body so it corresponds with the key of socket U1. Loosely insert the pins of the BQ2003 into socket U1. All 14 pins should fit freely into the socket openings. If not, straighten the IC

pins until they do. Using firm and steady pressure, fully seat the IC into the socket.

Locate the 2N3055 silicon power transistor. Note that the emitter and base leads are not centered on the device body.

- 11. Install the 2N3055 transistor at location Q1. Note that the device leads must be inserted so that Q1's heatsink aligns properly with the PC board mounting holes.
- 12. Find two 4-40 ¼" screws and two 4-40 nuts. Mount Q1 to the PC board using the 4-40 hardware. The nuts should be on the foil side of the board. Tighten the hardware until snug—the hardware provides an electrical path for the collector of this transistor.
- 13. After the hardware is tightened, solder and trim the emitter and base leads of the 2N3055 transistor.

Locate the IFR9530 power FET.

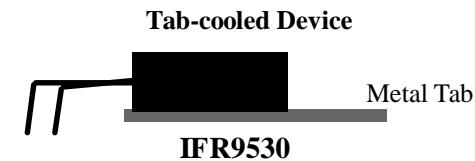

Temporarily place the IFR9530 at mounting location Q3. The device leads should be formed to align with three component lead holes, and the mounting hole on the heatsink tab should align with the mounting hole drilled in the PC board. Re-form leads as needed.

- 14. Install the IFR9530 at location Q3. Use the remaining 4-40 x ¼" screw and 4-40 nut supplied in the kit to mount the device (the nut should be placed on the IFR9530 heatsink tab). Tighten the hardware until snug (the hardware provides an electrical path). Solder and trim the component leads.

#### **Final Assembly:**

- 1. Locate the 500-uH wire-wound choke. Install and solder the choke at location L1.
- 2. Locate the 2.1mm coaxial style power connector jack. Install at location J1. Be sure the jack body is mounted flush to the board. Carefully bend over the solder-tabs for J1 so they are flush with the solder area on the PC board—this improves the mechanical strength of the solder connections. Solder the three tabs for J1.

Locate two of the DPDT push-action switches. Install and solder at the following locations (be sure switch body is mounted level to board before soldering):

**Important Note:** Do not install a push-action switch at location SW4 until directed to do so!

3. SW2 DPDT push-action switch

4. SW3 DPDT push-action switch

Locate the remaining DPDT push action switch. Activate the switch shaft several times and observe the off/on latching mechanism.

Reposition this clip for momentary operation

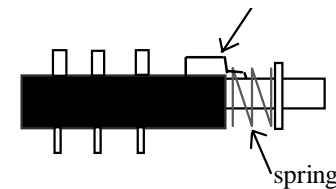

**Side view of SW4 switch**

This switch will be used at position SW4 to initiate a discharge cycle. The switch must be modified from latching action to momentary action. Note the clip shown in the diagram above. The front part of the clip (over the shaft and under the spring) holds the shaft from falling out of the switch body. The rear portion of the clip enters the switch body and sets the latching action. Carefully use a pair of tweezers or fine long-nosed pliers to lift the rear of the clip free of the switch body (do not lift the front end) and reposition the clip so it falls on the outside of the switch body (see the following diagram).

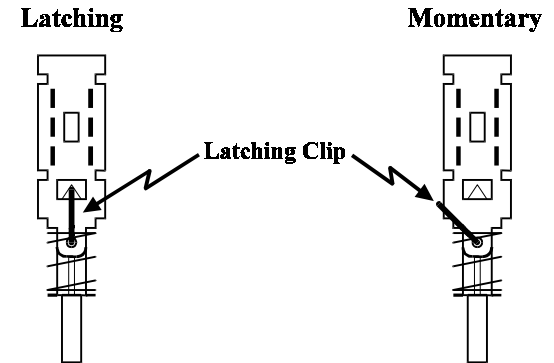

- 5. Install and solder the modified momentary-action switch at location SW4 (make sure the switch body remains level to the board while soldering).
- 6. Locate the 6-position double-pole rotary switch. Hold the switch, and rotate the shaft fully counterclockwise until the stop is reached. Rotate the switch clockwise counting the number of positions. There should be six positions. If not, rotate the shaft back to the fully counterclockwise position. Remove the mounting nut and lockwasher on the shaft bushing. This will reveal a second silver colored indexing-washer. This washer has a pin that corresponds to the desired stop position number etched on the switch body. If the washer pin is in a position other than position six, remove the pin, and try rotating the shaft counterclockwise. It may already be there, or the index pin may have been setting a false CCW stop. Realign the indexing washer pin into the proper pin sixth stop-position. Replace the lockwasher and mounting nut to hold the index washer in position. The switch should now have six positions.
- 7. Rotate the shaft of the 6-position switch fully counterclockwise. The “flat” of the shaft should now be aligned so it faces the small plastic post on the switch body.
- 8. Install the switch at location SW1—the flat of the shaft and plastic post should face the rear of the board, that is facing away from SW2 and SW4. Note that all pins of the switch must enter their respective solder holes. Straighten any bent pins before attempting insertion. With the switch body mounted flush to the board, solder all pins.
- 9. Locate the length of married RED/BLACK zip cable. At one end, carefully split the wires apart for a length of two inches. Remove ¼” of insulation from each wire.

- 10. Locate the legend for the negative battery wire ( - ) on the PC board. This is located in front of choke L1. Tightly twist the strands for the BLACK wire together, and insert in the opening marked ( - ). Solder and trim the black wire.
- 11. Locate the legend for the positive battery wire ( + ) on the PC board. Tightly twist the strands for the RED wire together, and insert in the opening marked ( + ). Solder and trim the red wire.

The other end of the married RED/BLACK cable will be used to connect the battery pack to the charger. At this time you may wish to provide a suitable connector to mate with the battery pack the charger is to be used with. The red lead connects to the positive battery termination, the black lead connects to the negative battery termination.

This completes the assembly of the VEC-412K Rapid Charger/Battery Conditioner. Before proceeding, please take some time for a quality-control inspection. Carefully verify that all parts are in the correct locations. Check each solder joint for unwanted bridges. Correct any poor solder joints.

## **TESTING**

Performing a test of the VEC-412K Rapid Charger/Battery Conditioner requires a good understanding of what the various switches and jumper settings are used for. We suggest reading the **Operating Instructions** on page 20 of the manual to become familiar with the unit's operation and setup procedures.

1. Select a battery pack that is known to be in good condition for the following tests. Power must be supplied from an external source—the current and voltage requirements are dependent on the battery pack to be tested. Set the shorting jumpers on headers HD1, HD2, HD3, HD4, HD5 and HD6 as directed in the **Operating Instructions**.
2. Set range switches SW3 and SW1 to correspond to the number of cells in the test battery pack (see Table 1).
3. Connect the RED battery charger lead to the positive battery terminal. Connect the BLACK battery charger lead to the negative battery terminal.
4. With the power supply connected, turn power switch SW2 on. The RED status LED (CR1) should indicate either **Fast Charging** or **Charger Pending**.

A **Charger Pending** status indication occurs when the battery pack is in a discharged condition (less than one volt per cell). At this point, the charger has initiated a trickle charge which will continue until each cell reaches a 1-volt charge. If the battery pack was charged before hand, and the Charge Pending

condition is shown, verify that the settings for range switches SW3 and SW1 correspond correctly with the number of cells in the battery pack. Refer to Table 4 for charge status.

A **Fast Charging** indication shows that the battery cells are each above 1-volt per cell, and fast charging has commenced. Pressing the momentary action **Discharge** switch SW4 should cause the charger to switch from fast charge to a discharging condition. This will drain the battery until each cell reaches the 1-volt discharge cut-off point. Fast charging will then resume automatically.

Status LED CR1 failing to light (or flash) indicates that the battery is:

1. Absent or open.
2. SW3 and SW1 range switches set for wrong number of cells.

You may place a milliamp meter in series with the battery to verify proper charge and discharge currents.

## **OPERATING INSTRUCTIONS**

**External power requirements:** The operating voltage and current requirements are determined by the battery being charged. Determine the number of cells in the battery pack (see Table 1). The supply voltage should be equal to or slightly greater than 2-volts per cell, plus another volt or two for headroom to compensate for the charger circuitry. For example, a 6-volt battery pack contains 5 cells. For this battery pack, the minimum external power supply voltage should be 11 or 12 volts. The supply voltage limits are 7 Vdc minimum and 21 Vdc maximum. Using voltages that greatly exceed the 2-volt-per-cell recommendation may result in saturation of the switching inductor L1 and improper charger operation. For packs with 10 or more cells, use a supply voltage of 21Vdc. For single cells, or battery packs with 3 or less cells, use a power supply voltage of about 8 Vdc.

The power supply should be capable of handling slightly more current than the Fast Charge current setting set by the jumpers in Table 2. A 1-amp, or greater, supply will meet all requirements. Power is supplied to the 2.1mm coaxial power jack J1. Center pin is positive. Push-action switch SW2 removes or applies power to the charger (OFF/ON switch).

**Setting the Range Switches:** Range switches SW3 and SW1 are set according to the cell count of the battery pack. This is determined by dividing the battery pack's rated voltage by 1.2. For example, an 8.4-volt battery pack contains 7 cells. Refer to Table 1.

Push-action switch SW3 determines if the battery pack contains between 1 to 6 cells (off) or 7 to 12 cells (on). The six-position rotary switch SW1 is set for 1

to 6 cells, or 7 to 12 cells—depending on the state of SW3. The yellow Range LED CR2 is lit when SW3 is off.

For battery packs containing **6 or less cells**, push-action range switch SW3 is set to **off** (shaft fully extended). When off, the YELLOW Range indicator LED CR2 will be lit. When SW3 is off the rotary range switch SW1 selects from 1 to 6 cells. Example: Rotary range switch SW1 is set to position 6 for a six-cell battery pack, and SW3 would be off (CR2 lit).

For battery packs containing **7 or more cells**, range switch SW3 must be **on**, or depressed. Yellow Range LED CR2 will be extinguished when SW3 is on. With SW3 on, the rotary switch SW1 selects from 7 (fully CCW at position 1) to 12 cells (fully CW, at position 6). Example: For a 9.6-volt battery pack containing 8 cells switch SW3 would be set to on (CR1 not lit) and range switch SW1 would be set to position 2.

Battery Pack Voltage	Number of cells	SW3 setting	SW1 setting
1.2	1	Off	1
2.4	2	Off	2
3.6	3	Off	3
4.8	4	Off	4
6	5	Off	5
7.2	6	Off	6
8.4	7	On	1 (7)
9.6	8	On	2 (8)
10.8	9	On	3 (9)
12	10	On	4 (10)
13.2	11	On	5 (11)
14.4	12	On	6 (12)

**Table 1.**

**Setting the Charge Rate Current:** The VEC-412K charger has three different charge rate currents: 250mA, 500mA and 1,000mA (1 amp). The Charge Current

is programmed by placing jumpers over Headers HD4 and HD5 as shown in Table 2.

Charge Rate Current	HD4	HD5
250 mA	1-2	2-3
500 mA	1-2	1-2
1,000 mA	2-3	1-2

**Table 2.**

How the shorting clip is placed over jumper pins:

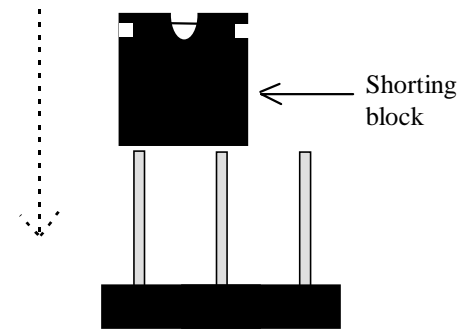

**Charge Rate Current** is set with the headers **HD4** and **HD5** labeled CHARGE CURRENT.

The Charge Rate Current is determined by the formula:

$$I_{cr} = \frac{\text{Capacity of Battery (mAh)}}{\text{Charge Time (hours)}}$$

**WARNING:** A too high charge current setting could cause cells to explode or rupture. Consult the battery manufacturer for the charging current specifications of your battery!

**Setting the Fast Charge Rate and Time Out:** Rechargeable batteries have a capacity, or C rating, associated with them. This value is defined in a milli-Amp hour rating, or mAh. The Fast Charge Rate is determined by the capacity C of the battery and by the time selected to charge the battery. The maximum Fast



Charge Rate recommended by the manufacturer should not be exceeded. Use the charge rate C/2 if this information is not available.

Fast Charge Rate	Time-Out	HD1	HD2
C/2	180 mins.	OPEN	AB
C	90 mins.	DE	BC
2C	45 mins.	DE	OPEN
4C	23 mins.	DE	AB

**Table 3. Fast charge rate Time-Out settings**

**Fast Charge Rate** and **Time Out** are set with headers HD2 and HD1.

For example, a 500-mAh battery may be safely fast-charged at the 2C Fast Charge Rating according to the manufacturer. The Charge Rate Current should be set to 2x the mAh rating, or 1000 mA (HD4 2-3, HD5 1-2). The Fast Charge Rate Time-Out should be set to 2C and 45 minutes (HD2 open, HD1 D-E).

**Battery Top Off:** Once a fast-charge cycle has completed, the charger will continue periodically charging the attach battery as needed, assuring the battery remains at full capacity. The Top Off charging current is a very low level and will not damage charged battery packs.

**Negative Increment of Voltage Detection Method:** This method of determining when a NiCd battery has reached full charge is controlled by the HD6 jumper position. When the jumper is in the ON position the *Negative Increment of Voltage Detection Method* is enabled.

#### **IMPORTANT INFORMATION!**

The *Negative Increment of Voltage Detection Method* can only be used for NiCad batteries. A large negative drop at the end of charge is characteristic of NiCads, and the charger senses this condition to determine the successful completion of a fast charge cycle. HD6 must be OFF when charging NiMH packs, as overcharging may result in dangerously high battery pack temperatures.

The *Negative Increment of Voltage Detection Method* is enabled by placing the jumper over the ON position of the HD6 header:

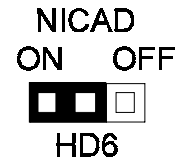

**HD6 must be OFF when fast charging NiMH battery packs!** NiMH batteries do not exhibit a voltage drop at full charge. NiMH battery temperatures can rapidly soar to dangerous levels if overcharged.

**Discharge-Before-Charge:** NiCad batteries can develop a so-called “memory” when seldom used and left charging for long periods of time. Activating momentary action switch SW4 will fully discharge the attached battery pack to the 1-volt-per-cell fully-discharged condition. NiCad battery packs should never be allowed to discharge below one-volt-per-cell or damage to the cells may occur. Allowing the pack to fully charge, and then performing a full discharge cycle by activating SW4 will exercise the cells, and help correct memory conditions. Several full charge/discharge cycles may be needed to fully erase a memory condition in troublesome battery packs. Note that once a discharge cycle has completed, the charger will automatically recharge the battery pack. Continued high charge and discharge rates will cause cell heating. Allow the battery time to cool between repeated memory cleansing cycles.

**Setting the Discharge Current:** Two discharge current rates are available: 120mA or 240mA. The jumper position on HD3 sets the discharge rate. Check the battery specifications for the maximum recommended discharge rate. A discharge rate equal to or less than the battery Capacity (C) is generally acceptable. Using the lowest discharge setting is advisable. The longer discharge time allows the cells to equalize their voltages, and gives the pack time to cool off after completion of a rapid charge.

**Starting the Discharge Cycle:** Providing the battery pack is above 1 volt-per-cell, depressing momentary-action switch SW4 will initiate a controlled discharge cycle until the 1 volt-per-cell discharge point is reached.

**STATUS Indicator LED CR1:** Observing the condition of Status LED CR1 will show the charger’s current activity. See Table 4.

Charger Status	Red status LED CR1 indication
Battery absent or wrong number of cells set-up	OFF

Charger Pending(trickle charge)	OFF for 1.375 sec and ON for 0.125 sec
Fast Charge	ON continuous
Discharge Cycle	ON for 1.375 sec and OFF for 0.125 sec
Charge complete and Top-Off	ON for 0.125 sec, OFF for 0.125 sec

**Table 4.**

The **status** of the controller is shown by the state of CR1, the red **Status** LED.

**Determining Full Charge:** For NiCd batteries, three methods of determining full charge are used: *Maximum Voltage Determination Method*, *Time-Out*, and a *Negative Increment of Voltage Detection Method*. The fast charging rate will cease if any of one of these three conditions are met.

The *Negative Increment of Voltage Detection Method* will not work on NiMH battery packs. During fast charge NiMH battery packs are monitored for maximum pack voltage, and the charging time is also limited by the Time Out setting.

**Maximum Voltage Determination Method:** When the battery pack reaches 1.82 volts-per-cell the charger concludes the fast charge cycle and enters the Top Off charging mode.

**Time Out:** See Table 3. When setting the Fast Charge Rate, a Time-Out setting is also determined. This is a fail-safe safety feature that prevents overcharging. If for some reason the battery fails the *Voltage Determination Method* or the *Negative Increment of Voltage Detection Method* for determining full charge, the Time-Out timer will end the fast charge cycle before battery damage occurs. The Time-Out timer allows sufficient time for a pack to reach a fully charged condition, unless defective.

**Getting the Best Charge:** NiCad battery capacity is reduced at very low or high temperatures. Do not charge batteries that are very warm or cold. Let batteries stabilize at room temperature before charging. Allow batteries a cooling off period between multiple charge/discharge memory cleansing cycles.

**Determining Battery Capacity:** Time how long it takes to fully discharge a charged battery pack. Multiply the number of hours by the discharge rate to find the mAh capacity of the battery. For example, a battery takes 2.3 hours to discharge at the 240 mA discharge setting.  $2.3 \text{ hours} \times 240 \text{ mA} = 552 \text{ mAh}$  (battery capacity C). Note: for best accuracy, use mA meter in series with the battery to find the exact discharge current.

**Battery Failure:** With proper care it is not unusual for NiCad battery packs to last 3, 4 or 5 years. Internal shorts often occur in older battery cells, or cells

may develop a very high internal resistance (open condition). These are failures, and can not be repaired by conditioning the battery. Battery packs that are discharged in heavy service beyond the 1 volt-per-cell discharge limit may have cells that became “reverse charged” and severely damaged in the process. Again, this damage cannot be repaired.

NiCads have a maximum number of discharge and charge cycles for their designed lifetime. Most NiCad damage occurs because NiCads are left charging for long periods of time—resulting in overheated cells or severe memory conditions. NiCads that do not respond to repeated cycling should be disposed of properly, they are considered to be a hazardous waste material. Your local landfill should have procedures in place to handle these materials.

Do not recharge primary cells (alkaline, etc.), or lead acid type batteries using the VEC-412K charger.

### **Glossary of Terms:**

**Battery Capacity:** Expressed as a fixed rate of current a battery can supply over a specified time interval, usually one hour, resulting in full discharge.

**Battery Pack:** An assembly containing two or more cells in series.

**Charge Current:** The current applied to a battery being charged.

**Charge Rate Current:** Capacity of battery in mAh divided by charge time in hours.

**Cycling:** Repeated and controlled charge/discharge cycling of a NiCd battery to remove a memory condition.

**Memory:** A condition where NiCd batteries lose capacity, mostly due to misuse.

**Negative Increment of Voltage Detection:** Sensing the voltage drop across a NiCd battery pack that occurs when it is fully charged as a method for ending the charge cycle.

**NiCad or NiCd:** Nickel Cadmium

**NiMH:** Nickel Metal Hydroxide

**Time Out:** A fail-safe timer setting that concludes the fast charge cycle after a set time interval lapses.

**Top Off:** A periodic charging cycle to keep a battery at its maximum charge capacity.

**A Practical Example:** Setting up the charger may appear to be a confusing task, but it is really much easier than it first appears.

Our example is a 6-volt 600-mA cordless phone battery. Table 1 shows this battery contains 5 individual cells. Since each cell requires 2-volts of supply

voltage, plus an extra 2-volts to compensate for losses in the charger circuitry, we will need a power supply capable of supplying 8 Vdc.

Since the cell count is between 1 and 6, Range Switch SW3 is set to the OFF position. Rotary Switch SW1 is set to position 5 as shown in Table 1 for a 5-cell battery pack.

We know the battery has a 600-mAh rating. What this means, in theory, is that the battery will supply 600-mA of current for one hour. Conversely, applying 600-mA of charging current for one hour should fully charge the battery. This is also theoretical. Charging involves losses, such as heat, and heat is wasted energy. Charging may require 70 or 80 minutes at a 600 mA charge rate current. Likewise, in reality a 600-mAh battery may be able to only deliver a maximum 300-mA current over a two-hour span.

The battery fast charge rate is not given on the battery label. To be safe, we will use the C/2 charge rate, 300 mA. Table 2 shows the closest Charge Rate Current is 250 mA. Table 3 shows for the C/2 fast charge rate the Time Out safety timer is 180 minutes, or 3 hours. 3 hours x 250 mA = 750 mAh. 150 mAh should provide enough margin to fully charge the 600 mAh battery.

At this point we also know our charger power supply must be rated for something greater than 250 mA.

For the 250-mA charge current, Table 2 shows a jumper must be placed on HD4 pins 1-2, and on HD5 pins 2-3.

For the C/2 fast charge rate, Table 3 shows HD2 has a jumper on A-B, and HD1 has no jumper applied (open).

We also don't know the maximum discharge rate specified for this battery. Since a discharge rate equal or less than the battery capacity C ( 600 mA) is acceptable, either the 120 mA or 240 mA discharge rate may be used. We will use the 240 mA discharge rate. The HD3 jumper is placed over the 240-mA position.

The battery label plainly identifies the battery as being a NiCd pack. The *Negative Increment of Voltage Detection* for NiCd packs is enabled by placing the jumper over the ON position of the HD6 header.

Attach the battery to the charger leads. The red charger lead is attached to the positive ( + ) battery terminal, the black charger lead is attached to the negative ( - ) battery terminal. With the power supply connected, the charger may be turned on using power switch SW2.

Upon turn on, the red Status LED CR1 will show the current charger activity. Refer to Table 4 to interpret the LED status indication.

## **IN CASE OF DIFFICULTY**

Only high-quality components and proven circuit designs are used in Vecronics kits. In very rare instances is a defective component the source of a problem. Replacement of defective parts is covered in the **Warranty** section. Ninety-five percent of the kits returned for factory repair are due to soldering problems or parts in the wrong locations. We advise repeating the assembly instructions step-by-step, looking for mistakes or soldering problems. Be especially wary of electrolytic capacitors and semiconductors. Kit builders often miss obvious mistakes. What is needed is a “fresh” set of eyes. Enlist a friend to go over your work.

*Always check the obvious!* Is the power supply plugged in? Is the power switch on?

Review the jumper configuration setups and double-check the settings.

Be sure that your power supply is able to handle the battery charging process of your cells.

Be absolutely sure the battery pack polarity is correct! Connect the battery's positive ( + ) lead to the **red** wire, and the battery's negative lead ( - ) to the **black** wire.

**Fast Charge Pending** status indication occurs while the battery voltage is outside the programmed limits. Double check the number of cells contained in your battery match with the settings on the range switch SW3 and rotary switch SW1.

If the charger is set for more cells than really are connected, the **STATUS** indicator LED will stay OFF.

If the charger (based on the **SW3** and **SW1** switch settings) reads a higher number of cells than the pack contains, it will read the battery as being discharged and then the **STATUS** indicator LED will stay on the **pending** mode. The **charger pending status** indicates that the battery cells voltage is below 1 V. This mode will occur with a discharged pack.

**Fuseable Run:** A short section of PC board foil near the 2.1mm power connector is designed to limit current flow by acting as a fuse. Excessive current will burn the foil run open. If this occurs, the cause of the catastrophic failure must be corrected before repairing the run and reapplying power.

**Enclosure:** When mounting the PC board in an enclosure, be careful that the mounting hardware does not accidentally bridge any nearby PC board foil runs. The clearance between the mounting holes and foil runs is minimal in some areas.

## **THEORY OF OPERATION AND SPECIFICATIONS**

### **Theory:**

The VEC-412K is a rapid battery charger and battery conditioner kit for NiCd (nickel cadmium) or NiMH (nickel-metal hydride) rechargeable batteries. The design incorporates a BQ2003 integrated circuit. This device is configured as a *Switch-Mode-Current-Regulator*—providing efficient energy transfer, reducing power dissipation and associated heating. It operates as a frequency modulated controller for switched regulation of the charging current. The unit uses three different fast-charging determination methods. For NiCd batteries a *maximum voltage*, *maximum time* or a *negative increment of voltage detection* are available. For Ni-MH batteries the drop in voltage as full charge is reached is not very big. In order to avoid overcharging NiMH batteries this method should be disabled via the HD6 jumper setting.

The charge controller uses the single cell voltage provided by this adjustable resistor divider network connected between the positive and the negative terminals on the battery. The divide count is controlled by range switch SW3 and rotary switch SW1. The BQ2003 IC views a battery pack as being a single “cell”. The range switches divide the pack voltage to that of a single cell for measurements. For example, to detect the 1 volt-per-cell full discharge point of a battery pack with ten cells, the battery pack voltage is divided by ten if the range switches are set properly. When the pack reaches 10 volts, or one volt per cell, the IC “sees” a 1 volt-per-cell reading for the pack.

The fast charge is only initiated if each cell in the pack is greater than 1 Vdc. If the cell voltage is less, the controller applies a trickle current until it senses the cells have reached 1 volt. The trickle charge is supplied to the battery through **R20** from the DC supply to the positive battery terminal.

During fast-charge the red status LED CR1 will be continuously ON. For the initial period of fast charge or hold-off, the voltage charge determination methods are disabled. The hold-off is a function of the charge rate selected by the Time-Out setting of the jumpers on **HD2** and **HD1**.

The maximum cell voltage (MCV) is set to 1.82V by the **R4-R5** divider network. Charging activity is halted if the cell voltage (BAT) is higher than the MCV. The BAT voltage is used to determine fast charge initiation and termination.

The discharge-before-charge function is used to condition NiCad batteries exhibiting a memory condition. The battery is discharged through a constant-current discharging circuit. The HD3 jumper sets the **DISCHARGE** rate to 120mA or 240mA.

**Specifications:**

Battery types.....	NiCad or NiMH
Charging current.....	250, 500 or 1,000 mA
Charging rate .....	C/2, C, 2C or 4C
Battery capacity.....	1 to 12 cell packs (1.2 to 14.4 Vdc)
Power requirements .....	7 to 21 Vdc, 1 amp max.
Discharge rates .....	120 or 240 mA
Indicators.....	LEDs, CR2 (pack size) CR1 (status)
PCB Dimensions .....	4.250" x 4.700"



**SCHEMATIC**

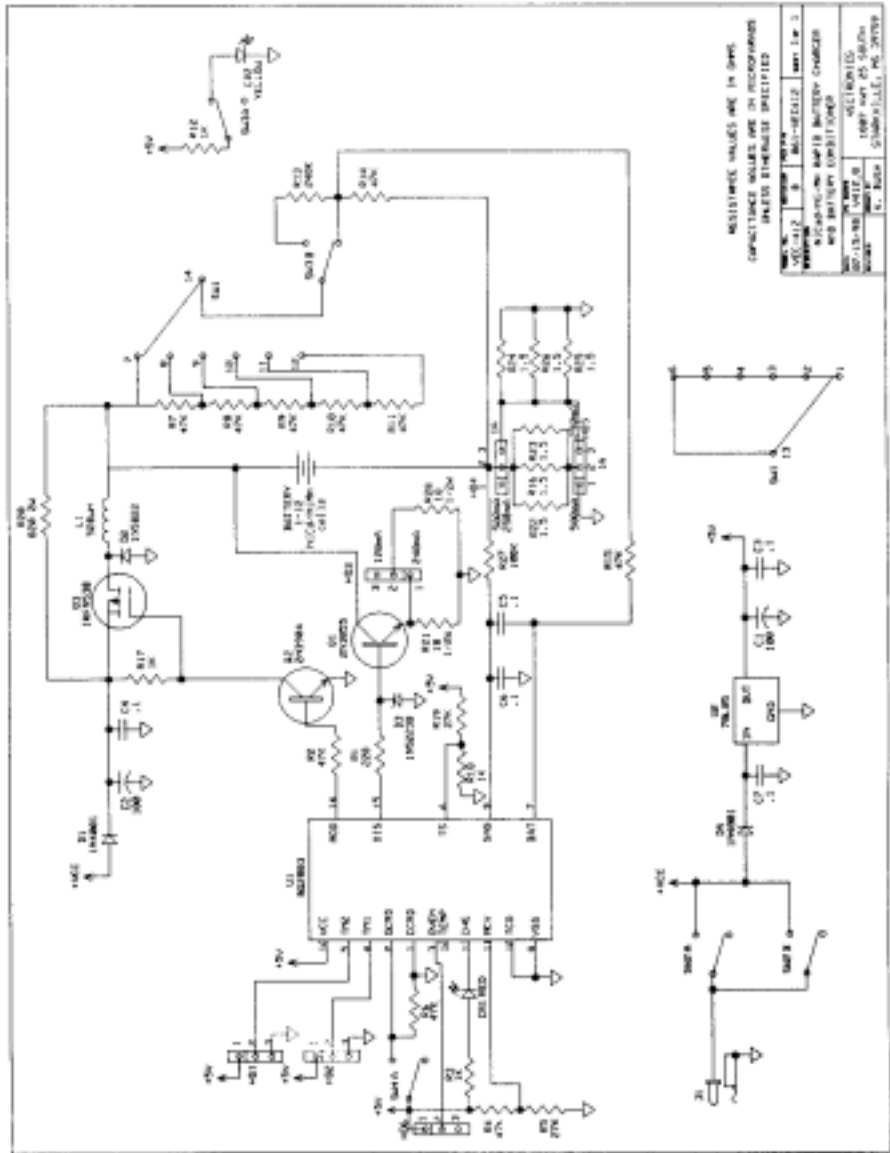

## **ENCLOSURE**

Vectronics has designed a matching enclosure just for your VEC-412K. The matching enclosure is an all metal box which includes knobs, hardware, decals, and rubber feet. **Enclosure model: VEC-412KC.**

To install your *Battery Charger/Conditioner* in the VEC-412KC matching enclosure follow these instructions (***read all instructions before beginning ... take your time***):

1. Find the front panel decal and rear panel decal; separate using scissors. Put the rear panel decal on first. This is done by: **a.)** Remove all debris and oil from the chassis. This should be done using a piece of cloth and alcohol. **b.)** Remove the crack and peel to expose the adhesive. **c.)** Place the decal on the rear panel without securing it completely. **d.)** Gently rub the alignment circles with your finger--if the circles are centered in the enclosure holes (also check the corner alignment marks) secure the decal by rubbing and removing all air bubbles. **e.)** If the alignment circles are not centered, adjust the decal accordingly then secure. **f.)** Use a penknife, or small Exacto™ knife, to cut away the unused edges (*cut from the adhesive side*) and cut out the component holes (*cut from the description side*). **g.)** Repeat for the front panel.
2. Next install the two L-brackets on the chassis using two of the 3/16" screws. The longer side of the L-bracket *must be* connected to the chassis using the two holes centered on each edge of the enclosure. Refer to the diagram on the next page for location and orientation.
3. Install the four 1/2" mounting screws next. Insert the screws, from the bottom, through the four holes relatively close to each corner of the chassis.
4. Place the four 3/16" round spacers on the mounting screws.
5. Now insert the PC board. This must be done by: **a.)** Insert the front of the PC board at an angle so the controls enter their respective holes. **b.)** Push the rear of the board in place. Make sure the mounting screws align with the mounting holes in the PC board before pushing.
6. Use the four hex nuts to secure the PC board. Be certain all appropriate components are centered with the enclosure holes before tightening.
7. Find switch caps. Align the red switch cap with SW2 and push it on. If it is difficult to push on, rotate it 90° and try again. Repeat for SW3 and SW4 using the black switch caps.
8. Locate the strain relief bushing. Place the red/black wire into the strain relief and lock. Insert the strain relief in the slot on the left rear of the enclosure. Make sure the connector strap, that holds the two parts of the strain relief together, is inserted into the slot first.
9. Find the remaining decal and trim with scissors. Use the corner marks as guides. Put this decal on now by: **a.)** Remove all debris and oil from the top. **b.)** Orient the top so the front is toward you. **c.)** Remove the crack and peel to expose the adhesive. **d.)** Place the decal on the top with the number 1 closest to the rear and use the switch hole as your guide. Do not secure it completely. **e.)** Gently rub the alignment circle with your finger--if the alignment circle is not centered adjust accordingly. **g.)** Use a penknife, or small Exacto™ knife, to cut out the switch hole.
10. Install the top now. First, insert the .343" black bushing into the switch hole on the top. Then, use the two remaining 3/16" screws for securing the top to the L-brackets. Make sure the L-brackets are aligned properly.
11. Locate and put the knob on the rotating switch (SW1); you may need to loosen the set screw. You may adjust the distance between the bottom of the knob and the bushing by removing the knob and trimming the shaft of the switch with a pair of cutters. Once you

