



**MOTOROLA**

**MTP700/MTP750  
Digital Portable Radios  
380 - 430 MHz  
806 - 870 MHz**

**Basic Service Manual**

Part Number: 6804113J98-O

\*6804113J98\*

March, 2004

# COPYRIGHT

## Computer Software Copyrights

The Motorola products described in this manual may include copyrighted Motorola computer programs stored in semiconductor memories or other media. Laws in the United States and other countries preserve for Motorola certain exclusive rights for copyrighted computer programs, including the exclusive right to copy or reproduce in any form, the copyrighted computer program. Accordingly, any copyrighted Motorola computer programs contained in the Motorola products described in this manual may not be copied or reproduced in any manner without the express written permission of Motorola. Furthermore, the purchase of Motorola products shall not be deemed to grant, either directly or by implication, estoppel or otherwise, any license under the copyrights, patents or patent applications of Motorola, except for the normal non-exclusive royalty-free license to use that arises by operation of law in the sale of a product.

---

## Trademarks

Motorola is the trademark of Motorola, Inc.

All other copyrights mentioned in this manual are trademarks of their respective companies.

# DOCUMENT HISTORY

The following major changes have been implemented in this manual since the previous edition:

<b>Edition</b>	<b>Description</b>	<b>Date</b>
684113J98-O	Initial edition	Mar. 2004

**THIS PAGE INTENTIONALLY LEFT BLANK**

# SAFETY

## Product Safety and RF Exposure for Portable Two-Way Radios



Caution

BEFORE USING THIS RADIO, READ THIS BOOKLET WHICH CONTAINS IMPORTANT OPERATING INSTRUCTIONS FOR SAFE USAGE AND RF ENERGY AWARENESS AND CONTROL INFORMATION FOR COMPLIANCE WITH RF ENERGY EXPOSURE LIMITS IN APPLICABLE NATIONAL AND INTERNATIONAL STANDARDS.

The information provided in this document supersedes the general information contained in user guides published prior to February 2002.

For radios that have been approved as intrinsically safe, read the instructions and information on intrinsic safety.

## Compliance with RF Energy Exposure Standards

**NOTICE:** This radio is intended for use in occupational/controlled applications where users have been made aware of the potential for exposure and can exercise control over their exposure. This radio device is **NOT** authorized for general population, consumer or similar use.

## Federal Communication Commission (FCC) Regulations

The FCC has established limits for safe exposure to radio frequency (RF) emissions from portable two-way radios. The FCC requires manufacturers to demonstrate compliance with RF exposure limits before portable two-way radios can be marketed in the U.S. When two-way radios are approved for occupational/controlled environment exposure limits, the FCC requires users to be fully aware of, and exercise control over, their exposure. Awareness and control of RF exposure can be accomplished by the use of labels, or by education or training through appropriate means, such as information and instructions in user manuals or safety booklets.

Your Motorola two-way radio has an RF exposure information label in the battery compartment. This user safety booklet includes useful information about RF exposure and helpful instructions on how to control your RF exposure.

Your Motorola two-way radio is designed and tested to comply with a number of national and international standards and guidelines (listed below) regarding human exposure to radio frequency electromagnetic energy. **This radio complies with the IEEE (FCC) and ICNIRP exposure limits for occupational/controlled RF exposure environments at usage factors of up to 50% talk–50% listen.** In terms of measuring RF energy for compliance with FCC exposure guidelines, **your radio radiates measurable RF energy only while it is transmitting (during talking), not when it is receiving (listening) or in standby mode.**

**NOTE:** The approved batteries, supplied with the portable radio, are rated for a 5-5-90 duty cycle (5% talk–5% listen–90% standby), even though this radio complies with FCC occupational exposure limits at usage factors of up to 50% talk.

### Your Motorola two-way radio complies with the following RF energy exposure standards and guidelines:

- United States Federal Communications Commission, Code of Federal Regulations; 47 CFR part 2 sub-part J
- American National Standards Institute (ANSI) / Institute of Electrical and Electronic Engineers (IEEE) C95. 1-1992
- Institute of Electrical and Electronic Engineers (IEEE) C95.1-1999 Edition
- International Commission on Non-Ionizing Radiation Protection (ICNIRP) 1998
- Ministry of Health (Canada) Safety Code 6. Limits of Human Exposure to Radiofrequency Electromagnetic Fields in the Frequency Range from 3 kHz to 300 GHz, 1999
- Australian Communications Authority Radiocommunications (Electromagnetic Radiation - Human Exposure) Standard, 2001
- ANATEL, Brasil Regulatory Authority, Resolution 256 (April 11, 2001) "additional requirements for SMR, cellular and PCS product certification."

## Compliance and Control Guidelines and Operating Instructions for Portable Two-Way Radios

To control your exposure and ensure compliance with the occupational/ controlled environment exposure limits, always adhere to the following procedures:

- Transmit no more than 50% of the time. To transmit (talk), push the Push-To-Talk (PTT) button. To receive calls, release the PTT button. Transmitting 50% of the time or less is important since the radio generates measurable RF energy exposure only when transmitting (in terms of measuring standards compliance).
- **Hold the radio in a vertical position in front of the face with the microphone (and other parts of the radio including the antenna) at least one to two inches (2.5 to 5 centimeters) away from the lips. Keeping the radio at a proper distance is important since RF exposures decrease with distance from the antenna.** 
- For body-worn operation, always place the radio in a Motorola-approved clip, holder, holster, case, or body harness for this product. Using non-Motorola-approved accessories may result in exposure levels which exceed the FCC's occupational/controlled environment RF exposure limits.
- If you are not using a body-worn accessory and are not using the radio in the intended use position in front of the face, ensure the antenna and the radio are kept one inch (2.5 centimeters) from the body when transmitting. Keeping the radio at a proper distance is important since RF exposures decrease with distance from the antenna.
- **Use only Motorola-approved supplied or replacement antennas, batteries, and accessories.** Use of non-Motorola-approved antennas, batteries and accessories may exceed FCC RF exposure guidelines. **For a list of Motorola-approved antennas, batteries, and other accessories, visit the following web site which lists approved accessories:**  
**<http://ap.cgiss.motorola.com/AAD/index.html>**

For additional information on exposure requirements or other training information, visit <http://www.motorola.com/rfhealth>.

## Electromagnetic Interference/Compatibility

**NOTE:** Nearly every electronic device is susceptible to electromagnetic interference (EMI) if inadequately shielded, designed, or otherwise configured for electromagnetic compatibility.

## Facilities

To avoid electromagnetic interference and/or compatibility conflicts, turn off your radio in any facility where posted notices instruct you to do so. Hospitals or health care facilities may be using equipment that is sensitive to external RF energy.

## Aircraft

When instructed to do so, turn off your radio when on board an aircraft. Any use of a radio must be in accordance with applicable regulations per airline crew instructions.

## Medical Devices

### *Pacemakers*

The Advanced Medical Technology Association (AdvaMed) recommends that a minimum separation of 6 inches (15 centimeters) be maintained between a handheld wireless radio and a pacemaker. These recommendations are consistent with those of the U.S. Food and Drug Administration.

#### **Persons with pacemakers should:**

- ALWAYS keep the radio more than 6 inches (15 centimeters) from their pacemaker when the radio is turned ON.
- not carry the radio in the breast pocket.
- use the ear opposite the pacemaker to minimize the potential for interference.
- turn the radio OFF immediately if you have any reason to suspect that interference is taking place.

### *Hearing Aids*

Some digital wireless radios may interfere with some hearing aids. In the event of such interference, you may want to consult your hearing aid manufacturer to discuss alternatives.

### *Other Medical Devices*

If you use any other personal medical device, consult the manufacturer of your device to determine if it is adequately shielded from RF energy. Your physician may be able to assist you in obtaining this information.

## Driver Safety

Check the laws and regulations on the use of radios in the area where you drive. Always obey them.

#### **When using your radio while driving, please:**

- Give full attention to driving and to the road.
- Use hands-free operation, if available.
- Pull off the road and park before making or answering a call if driving conditions so require.

## Operational Warnings



### WARNING

#### For Vehicles With An Air Bag

Do not place a portable radio in the area over an air bag or in the air bag deployment area. Air bags inflate with great force. If a portable radio is placed in the air bag deployment area and the air bag inflates, the radio may be propelled with great force and cause serious injury to occupants of the vehicle.

#### Potentially Explosive Atmospheres

Turn off your radio prior to entering any area with a potentially explosive atmosphere, unless it is a portable radio type especially qualified for use in such areas as “Intrinsically Safe” (for example, Factory Mutual, CSA, UL, or CENELEC). Do not remove, install, or charge batteries in such areas. Sparks in a potentially explosive atmosphere can cause an explosion or fire resulting in bodily injury or even death.

The areas with potentially explosive atmospheres referred to above include fueling areas such as below decks on boats, fuel or chemical transfer or storage facilities, and areas where the air contains chemicals or particles such as grain, dust or metal powders. Areas with potentially explosive atmospheres are often but not always, posted.

#### Blasting Caps And Blasting Areas

To avoid possible interference with blasting operations, turn off your radio when you are near electrical blasting caps, in a blasting area, or in areas posted: “Turn off two-way radio.” Obey all signs and instructions.

## Operational Cautions



### Caution

#### Antennas

Do not use any portable radio that has a damaged antenna. If a damaged antenna comes into contact with your skin, a minor burn can result.

#### Batteries

All batteries can cause property damage and/or bodily injury such as burns if a conductive material such as jewelry, keys, or beaded chains touch exposed terminals. The conductive material may complete an electrical circuit (short circuit) and become quite hot. Exercise care in handling any charged battery, particularly when placing it inside a pocket, purse, or other container with metal objects.

## Intrinsically Safe Radio Information

### FMRC Approved Equipment

Anyone intending to use a radio in a location where hazardous concentrations of flammable materials exist (hazardous atmosphere) is advised to become familiar with the subject of intrinsic safety and with the National Electric Code NFPA 70 (National Fire Protection Association) Article 500 (hazardous [classified] locations).

An Approval Guide, issued by Factory Mutual Research Corporation (FMRC), lists manufacturers and the products approved by FMRC for use in such locations. FMRC has also issued a voluntary approval standard for repair service (“Class Number 3605”).

FMRC Approval labels are attached to the radio to identify the unit as being FMRC Approved for specified hazardous atmospheres. This label specifies the hazardous Class/Division/Group along with the part number of the battery that must be used. Depending on the design of the portable unit, this FM label can be found on the back or the bottom of the radio housing. The FM Approval Mark is shown here.







- **Do not operate radio communications equipment in hazardous atmospheres unless it is a type specifically qualified (e.g., FM Approved) for such use. An explosion or fire may result.**
- **Do not operate the FMRC Approved Product in a hazardous atmosphere if it has been physically damaged (e.g., cracked housing). An explosion or fire may result.**
- **Do not replace or charge batteries in a hazardous atmosphere. Contact sparking may occur while installing or removing batteries, and cause an explosion or fire.**
- **Do not replace or change accessories in a hazardous atmosphere. Contact sparking may occur while installing or removing accessories, and cause an explosion or fire.**
- **Turn the radio off before removing or installing a battery or accessory.**
- **Do not disassemble an FMRC Approved Product in any way that exposes the internal circuits of the unit.**

Radios must ship from the Motorola manufacturing facility with the hazardous atmosphere capability and FM Approval labeling. Radios will not be “upgraded” to this capability and labeled in the field. A modification changes the unit’s hardware from its original design configuration. Modifications can only be made by the original product manufacturer at one of its FMRC-audited manufacturing facilities.



- **Failure to use an FMRC Approved Product with an FMRC Approved battery or FMRC Approved accessories specifically approved for that product may result in the dangerously unsafe condition of an unapproved radio combination being used in a hazardous location.**
- **Unauthorized or incorrect modification of an FMRC Approved Product will negate the Approval rating of the product**

## Repair of FMRC Approved Products

REPAIRS FOR MOTOROLA PRODUCTS WITH FMRC APPROVAL ARE THE RESPONSIBILITY OF THE USER.

You should not repair or relabel any Motorola-manufactured communication equipment bearing the FMRC Approval label (“FMRC Approved Product”) unless you are familiar with the current FMRC Approval standard for repairs and service (“Class Number 3605”).

You may want to consider using a repair facility that operates under 3605 repair service approval.



- **Incorrect repair or relabeling of any FMRC Approved Product could adversely affect the Approval rating of the unit.**
- **Use of a radio that is not intrinsically safe in a hazardous atmosphere could result in serious injury or death.**

The FMRC’s Approval Standard Class Number 3605 is subject to change at any time without notice to you. You may want to obtain a current copy of 3605 from the FMRC. Per the December 1994 publication of 3605, some key definitions and service requirements are as follows:

### *Repair*

A repair constitutes something done internally to the unit that would bring it back to its original condition—Approved by FMRC. A repair should be done in an FMRC Approved repair facility.

Items not considered as repairs are those in which an action is performed on a unit which does not require the outer casing of the unit to be opened in a manner which exposes the internal electrical circuits of the unit. You do not have to be an FMRC Approved repair facility to perform these actions.

## *Relabeling*

The repair facility shall have a method by which the replacement of FMRC Approval labels are controlled to ensure that any relabeling is limited to units that were originally shipped from the manufacturer with an FM Approval label in place. FMRC Approval labels shall not be stocked by the repair facility. An FMRC Approval label shall be ordered from the original manufacturer, as needed, to repair a specific unit. Replacement labels may be obtained and applied by the repair facility, provided there is satisfactory evidence that the unit being relabeled was originally an FMRC Approved unit. Verification may include, but is not limited to a unit with a damaged Approval label, a unit with a defective housing displaying an Approval label, or a customer invoice indicating the serial number of the unit and purchase of an FMRC Approved model.

## **Do Not Substitute Options or Accessories**

The Motorola communications equipment certified by Factory Mutual is tested as a system and consists of the FM Approved portable, FM Approved battery, and FM Approved accessories or options, or both. This FM Approved portable and battery combination must be strictly observed. There must be no substitution of items, even if the substitute has been previously Approved with a different Motorola communications equipment unit. Approved configurations are listed in the FM Product Listing Manual that was included with your radio.

## **European Union Directives Conformance Statement**

This product is in conformance with the TETRA (TErrestrial Trunked RADIO) standard.  
This product is in conformance with the requirements of the applicable EU Council Directives.  
Declarations of Conformance with the requirements are located at:

Motorola a/s  
Sydvestvej 15  
DK-2600 Glostrup

Denmark

# CONTENTS

<b>COPYRIGHT</b>	Computer Software Copyrights .....	ii
	Trademarks .....	ii
<b>HISTORY</b>	<b>DOCUMENT HISTORY</b> .....	<b>iii</b>
<b>SAFETY</b>	Product Safety and RF Exposure for Portable Two-Way Radios .....	v
<b>CHAPTER 1</b>	<b>SCOPE &amp; WARRANTY INFORMATION</b> .....	<b>1-1</b>
	Scope Of This Manual .....	1-1
	Manual Revisions .....	1-1
	Related Publications .....	1-1
	Warranty and Service Support .....	1-2
	European Radio Support Centers (ERSC) .....	1-3
	Asia Pacific Radio Support Centers .....	1-4
	Latin America Radio Support Centers .....	1-5
<b>CHAPTER 2</b>	<b>MODEL INFORMATION &amp; ACCESSORIES</b> .....	<b>2-1</b>
	MTP700 Portable Radio Model Charts .....	2-1
	MTP750 Portable Radio Model Charts .....	2-5
	MTP700/MTP750 Portable Radio Model Information .....	2-7
	MTP700/MTP750 Portable Radio Model Specification .....	2-8
	MTP700/MTP750 Accessories-To-Model Chart .....	2-9
<b>CHAPTER 3</b>	<b>OVERVIEW</b> .....	<b>3-1</b>
	General .....	3-1
	Digital Modulation Technology .....	3-1
<b>CHAPTER 4</b>	<b>PROGRAMMING THE RADIO</b> .....	<b>4-1</b>
	Before Using the Customer Programming Software (CPS) .....	4-1
	Reading Codeplug .....	4-2
	Programming Codeplug .....	4-2
	Programming Frequency .....	4-3
	Restoring Factory Frequencies of the Radio .....	4-4
	Programming Firmware .....	4-4
	Manual Mode Testing .....	4-5
	Preparation for Testing .....	4-5
	Tests .....	4-5
	LCD Display Test .....	4-5

<b>CHAPTER 5</b>	<b>TEST SETUP &amp; TESTING</b> .....	<b>5-1</b>
	Typical Test Setup .....	5-1
	Test Equipment .....	5-2
	Test Check List .....	5-3
	How to Configure the IFR 2968 System Setup .....	5-5
	How to Configure the IFR 2968 Manual Test Screen .....	5-7
	RF Tests .....	5-8
	Test Page .....	5-8
	Receiver Tests .....	5-8
	Transmitter Tests .....	5-10
	Call Processing Test .....	5-10
	Duplex Test (Phone/Private Mode) .....	5-11
	DMO Test .....	5-13
	IFR 2968 Test Setup .....	5-13
	How to Configure the IFR 2968 Manual Test Screen .....	5-13
	Radio Configuration for DMO .....	5-13
	RF Test - Transmit Test .....	5-14
	Service Flow Chart .....	5-15
<b>CHAPTER 6</b>	<b>MAINTENANCE</b> .....	<b>6-1</b>
	Introduction .....	6-1
	Preventive Maintenance .....	6-1
	Safe Handling of CMOS and LDMOS Devices .....	6-3
	Repair Procedures and Techniques — General .....	6-4
	Parts Replacement and Substitution .....	6-4
	Disassembling and Reassembling the Radio - General .....	6-4
	Radio Disassembly - Detailed .....	6-5
	Front Cover from Chassis Disassembly .....	6-5
	Chassis Assembly Disassembly .....	6-8
	Radio Reassembly - Detailed .....	6-9
	Chassis Assembly Reassembly .....	6-9
	Chassis and Front Cover Reassembly .....	6-9
	Service Aids .....	6-11
	MTP700/MTP750 Unit - Exploded View .....	6-12
<b>APPENDIX A</b>	<b>REPLACEMENT PARTS AND KITS</b> .....	<b>A-1</b>
	Servicing MTP700/MTP750 Portable Units .....	A-1
	Replacement Parts .....	A-1
	Service Kits .....	A-2
<b>APPENDIX B</b>	<b>CONNECTOR PIN FUNCTIONS</b> .....	<b>B-1</b>
	General .....	B-1
	Side Accessory Connector Pin Assignment .....	B-1
	Bottom Accessory Connector Pin Assignment .....	B-3

# CHAPTER 1

## SCOPE & WARRANTY INFORMATION

### Scope Of This Manual

This manual contains information necessary to identify and troubleshoot the MTP700/MTP750 Dimetra Portable Radio at the board level. It also contains information on radio assembling, disassembling, and maintenance. Depending on the radio application, these radios are designed to work with Motorola's Dimetra system or other TETRA compliant systems.

Accordingly, information in this manual is divided into the following chapters and appendices:

- SAFETY Product Safety and RF Exposure for Portable Two-Way Radios
- CHAPTER 1 Scope & Warranty Information
- CHAPTER 2 Model Information & Accessories
- CHAPTER 3 Overview
- CHAPTER 4 Programming the Radio
- CHAPTER 5 Test Setup & Testing
- CHAPTER 6 Maintenance
- APPENDIX A Replacement Parts and Kits
- APPENDIX B Connector Pin Functions

### Manual Revisions

Changes which occur after this manual is printed are described in Manual Revisions. These Manual Revisions provide complete information on changes including pertinent parts listing data.

### Related Publications

6804113J89	MTP700 User Guide (English)
6804113J87	MTP700 User Guide (Traditional Chinese)
6804112J75	MTP700 User Guide (Simplified Chinese)
6804113J42	MTP700 User Guide (Korean)
6804113J81	MTP750 Basic User Guide (English/Simplified Chinese)
6804113J91	MTP750 Basic User Guide (English/Traditional Chinese)
6804113J82	MTP750 Full Feature User Guide (English)
6804113J83	MTP750 Full Feature User Guide (Traditional Chinese)
6804113J97	MTP750 Full Feature User Guide (Simplified Chinese)
6804113J99	MTP700/MTP750 Detailed Service Manual (English)
6802971C15	MTP700 Customer Programming Software (CPS) Start-up manual
6804110J47	Safety Leaflet (English/Mandarin)
6802300U57	EME Warnings, Pocket Size
6866534D69	R&TTE Leaflet (for EMEA region only)
6866534D94	Factory Mutual Supplement

## Warranty and Service Support

Motorola offers long term support for its products. This support includes full exchange and/or repair of the product during the warranty period, and service/repair or spare parts support out of warranty. Any "return for exchange" or "return for repair" by an authorised Motorola Dealer must be accompanied by a Warranty Claim Form. Warranty Claim Forms are obtained by contacting an Authorised Motorola Dealer.

### Warranty Period and Return Instructions

The terms and conditions of warranty are defined fully in the Motorola Dealer or Distributor or Reseller contract. These conditions may change from time to time and the following notes are for guidance purposes only.

In instances where the product is covered under a "return for replacement" or "return for repair" warranty, a check of the product should be performed prior to shipping the unit back to Motorola. This is to ensure that the product has been correctly programmed or has not been subjected to damage outside the terms of the warranty.

Prior to shipping any radio back to the appropriate Motorola warranty depot, please contact Customer Resources. All returns must be accompanied by a Warranty Claim Form, available from your Customer Services representative. Products should be shipped back in the original packaging, or correctly packaged to ensure no damage occurs in transit.

### After Warranty Period

After the Warranty period, Motorola continues to support its products in two ways.

1. Motorola's Regional Radio Support Centers offer repair services to both end users and dealers at competitive prices.
2. AAD supplies individual parts and modules that can be purchased by dealers who are technically capable of performing fault analysis and repair.

## European Radio Support Centers (ERSC)

Austria:	06 60 75 41	Italy:	16 78 77 387
Belgium:	08 00 72 471	Luxemburg:	08 00 23 27
Denmark:	80 01 55 72	Netherlands:	60 22 45 13
Finland:	08 00 11 49 10	Norway:	80 01 11 15
France:	05 90 30 90	Portugal:	05 05 49 35 70
Germany:	08 00 18 75 240	Spain:	90 09 84 902
Greece:	00 80 04 91 29 020	Sweden:	02 07 94 307
UK :	08 00 96 90 95	Switzerland:	1 55 30 82
Ireland:	18 00 55 50 21	Iceland:	80 08 147

Or dial Customer Care Center:

Tel: +49 6128 70 2164

Please use these numbers for repair enquiries only.

### Piece Parts

Some replacement parts, spare parts, and/or product information can be ordered directly. If a complete Motorola part number is assigned to the part, it is available from Motorola Radio Aftermarket and Accessory Division (AAD). If no part number is assigned, the part is not normally available from Motorola. If a parts list is not included, this generally means that no user-serviceable parts are available for that kit or assembly.

Note on this digital TETRA Radio: **The CPS has no capability to tune the radio. Tuning the radio can only be performed at the factory or at the appropriate Motorola Repair Center. Component replacement can affect the radio tuning and must only be performed by the appropriate Motorola Repair Center.**

### Parts Identification and Ordering

Request for help in identification of non-referenced spare parts should be directed to the Customer Care Organisation of Motorola's local area representation. Orders for replacement parts, kits and assemblies should be placed directly on Motorola's local distribution organisation or via Motorola Online (Extranet).

### EMEA Test Equipment Support

Information related to support and service of Motorola Test Equipment is available via Motorola Online (Extranet), through the Customer Care Organisation of Motorola's local area representation or by calling the Motorola switchboard in Germany using phone number +49 6128 700.

## Asia Pacific Radio Support Centers

### Piece Parts

Some replacement parts, spare parts, and/or product information can be ordered directly. If a complete Motorola part number is assigned to the part, it is available from Motorola Radio Aftermarket and Accessory Division (AAD). If no part number is assigned, the part is not normally available from Motorola. If a parts list is not included, this generally means that no user-serviceable parts are available for that kit or assembly.

Note on this digital TETRA Radio: **The CPS has no capability to tune the radio. Tuning the radio can only be performed at the factory or at the appropriate Motorola Repair Center. Component replacement can affect the radio tuning and must only be performed by the appropriate Motorola Repair Center.**

All orders for parts/information should include the complete Motorola identification number. All part orders should be directed to your local AAD office. Please refer to your latest price pages.

### Technical Support

Technical support is available to assist the dealer/distributor in resolving any malfunction which may be encountered. Initial contact should be by telephone wherever possible. When contacting Motorola Technical Support, be prepared to provide the product **model number** and the unit's **serial number**.

### Further Assistance From Motorola

You can also call the CGISS Indirect Business Customer Help Desk number, (604)-6302525 or send an email to [customercare.asia@motorola.com](mailto:customercare.asia@motorola.com).



---

## Latin America Radio Support Centers

The Customer Support is available through the following service numbers:

**Warranty and Repairs:**

Motorola De Colombia Service Center  
Diagonal 127A no. 17-64  
Santa Fe de Bogotá  
Colombia  
(571) 520-0510 or (571) 657-5759

Motorola De Mexico Service Center  
Bosques de Alisos #125  
Col. Bosques de las Lomas  
CP 05120 Mexico DF  
5252576700

**Piece Parts:**

To order parts in Latin America and the Caribbean:  
7:00 A.M. to 7:00 P.M. (Central Standard Time)  
Monday through Friday (Chicago, USA)  
1-847-538-8023

**Technical Support:**

lataech1@email.mot.com <mailto:lataech1@email.mot.com>

**Motorola Parts (Accessories and Aftermarket Division AAD):**

Attention: Order Processing  
1313 E. Algonquin Road  
Schaumburg, IL. 60196

**Parts Identification:**

1-847-538-0021 (Voice)  
1-847-538-8194 (Fax)

### Piece Parts

Some replacement parts, spare parts, and/or product information can be ordered directly. If a complete Motorola Part number is assigned to the part, it is available from Motorola Radio Aftermarket and Accessory Division (AAD). If no part number is assigned, the part is not normally available from Motorola. If a parts list is not included, this generally means that no user-serviceable parts are available for that kit or assembly.

Note on this digital TETRA Radio: **The CPS has no capability to tune the radio. Tuning the radio can only be performed at the factory or at the appropriate Motorola Repair Center. Component replacement can affect the radio tuning and must only be performed by the appropriate Motorola Repair Center.**

**THIS PAGE INTENTIONALLY LEFT BLANK**

## CHAPTER 2

# MODEL INFORMATION & ACCESSORIES

### MTP700 Portable Radio Model Charts

<b>MTP700, 380-430 MHz</b>					
<b>Model</b>			<b>Description</b>		
H47QCM6TZ6AN			MTP700 380-430 MHz 1W 25K CR PT911E		
*H47QCM6TZ6AB			MTP700 380-430 MHz 1W 25K CR PT911E		
H47QCM6TZ5AN			MTP700 380-430 MHz 1W 25K ES PT911E		
*H47QCM6TZ5AB			MTP700 380-430 MHz 1W 25K ES PT911E		
<b>Item</b>			<b>Description</b>		
x			**PMUE1852_	***MTP700 Super Tanapa 380-430 MHz 1W 25K CR-TEA1	
		x	**PMUE1853_	***MTP700 Super Tanapa 380-430 MHz 1W 25K ES-TEA1	
x			**PMUE1856_	***MTP700 Super Tanapa 380-430 MHz 1W 25K CR-TEA2	
		x	**PMUE1857_	***MTP700 Super Tanapa 380-430 MHz 1W 25K ES-TEA2	
x	x		**PMUE1825_	***MTP700 Super Tanapa 380-430 MHz 1W 25K CR	
		x	x	**PMUE1826_	***MTP700 Super Tanapa 380-430 MHz 1W 25K ES
x			**PMUE2052_	MTP700 Super Tanapa 380-430 MHz 1W 25K CR (Chinese)	
		x	**PMUE2053_	MTP700 Super Tanapa 380-430 MHz 1W 25K ES (Chinese)	
x			**PMUE2054_	MTP700 Super Tanapa 380-430 MHz 1W 25K CR (Korean)	
		x	**PMUE2055_	MTP700 Super Tanapa 380-430 MHz 1W 25K ES (Korean)	
x			**PMUE2056_	MTP700 Super Tanapa 380-430 MHz 1W 25K CR-TEA1 (Chinese)	
		x	**PMUE2057_	MTP700 Super Tanapa 380-430 MHz 1W 25K ES-TEA1 (Chinese)	
x			**PMUE2058_	MTP700 Super Tanapa 380-430 MHz 1W 25K CR-TEA1 (Korean)	
		x	**PMUE2059_	MTP700 Super Tanapa 380-430 MHz 1W 25K ES-TEA1 (Korean)	
x	x		**PMUE1865_	***MTP700 Tanapa 380-430 MHz 1W 25K CR	
		x	x	**PMUE1827_	***MTP700 Tanapa 380-430 MHz 1W 25K ES
		x	**PMUE2086_	MTP700 Tanapa 380-430 MHz 1W 25K ES (Chinese)	
x			**PMUE2087_	MTP700 Tanapa 380-430 MHz 1W 25K CR (Chinese)	
		x	**PMUE2088_	MTP700 Tanapa 380-430 MHz 1W 25K ES (Korean)	
x			**PMUE2089_	MTP700 Tanapa 380-430 MHz 1W 25K CR (Korean)	
		x	PMHE4012_	Back Chassis Kit 380-430 MHz 1W 25K ES	
x			PMHE4013_	Back Chassis Kit 380-430 MHz 1W 25K CR	
x			PMHN4048_	MTP700 Front Housing Kit CR (English/Chinese)	
x			PMHN4049_	MTP700 Front Housing Kit CR (English/Korean)	
x	x		PMHN4038_	MTP700 Front Housing Kit CR	

<b>MTP700, 380-430 MHz (Continued)</b>					
<b>Model</b>				<b>Description</b>	
H47QCM6TZ6AN				MTP700 380-430 MHz 1W 25K CR PT911E	
*H47QCM6TZ6AB				MTP700 380-430 MHz 1W 25K CR PT911E	
H47QCM6TZ5AN				MTP700 380-430 MHz 1W 25K ES PT911E	
*H47QCM6TZ5AB				MTP700 380-430 MHz 1W 25K ES PT911E	
<b>Item</b>				<b>Description</b>	
	x	x	PMHN4039_	MTP700 Front Housing Kit ES	
	x		PMHN4050_	MTP700 Front Housing Kit ES (English/Chinese)	
	x		PMHN4051_	MTP700 Front Housing Kit ES (English/Korean)	
x	x	x	x	FAE6000_	Narrow Band Antenna 380-400 MHz
x	x	x	x	FAE6001_	Narrow Band Antenna 410-430 MHz
x	x	x	x	FAE5520_	Whip Antenna 380-400 MHz
x	x	x	x	FAE6002_	Whip Antenna 410-430 MHz
x	x	x	x	6804113J89	MTP700 User Guide (English)
x	x	x	x	6804113J87	MTP700 User Guide (Traditional Chinese)
x	x	x	x	6804112J75	MTP700 User Guide (Simplified Chinese)
x	x	x	x	6804113J42	MTP700 User Guide (Korean)

## Note:

- x Indicates one of each is required.
- \* For Asia, please use H415EK Option for Bulk Package.
- \*\* For replacement kits, see Appendix A Replacement Parts and Kits.
- \*\*\* Not Field Replaceable for Latin America

<b>MTP700, 806-870 MHz</b>					
<b>Model</b>				<b>Description</b>	
H47XCM6TZ5AK				MTP700 806-870 MHz 1W 25K ES PT711E (Korea)	
H47XCM6TZ6AN				MTP700 806-870 MHz 1W 25K CR PT711E	
*H47XCM6TZ6AB				MTP700 806-870 MHz 1W 25K CR PT711E	
H47XCM6TZ5AN				MTP700 806-870 MHz 1W 25K ES PT711E	
*H47XCM6TZ5AB				MTP700 806-870 MHz 1W 25K ES PT711E	
<b>Item</b>				<b>Description</b>	
x				**PMUF1092_	***MTP700 Super Tanapa 806-870 MHz 1W 25K CR-TEA1
		x		**PMUF1093_	***MTP700 Super Tanapa 806-870 MHz 1W 25K ES-TEA1
x				**PMUF1096_	***MTP700 Super Tanapa 806-870 MHz 1W 25K CR-TEA2
		x		**PMUF1097_	***MTP700 Super Tanapa 806-870 MHz 1W 25K ES-TEA2
x	x			**PMUF1077_	***MTP700 Super Tanapa 806-870 MHz 1W 25K CR
		x	x	**PMUF1078_	***MTP700 Super Tanapa 806-870 MHz 1W 25K ES
x				**PMUF1115_	MTP700 Super Tanapa 806-870 MHz 1W 25K ES
x				**PMUF1157_	MTP700 Super Tanapa 806-870 MHz 1W 25K CR (Chinese)
		x		**PMUF1158_	MTP700 Super Tanapa 806-870 MHz 1W 25K ES (Chinese)
x				**PMUF1159_	MTP700 Super Tanapa 806-870 MHz 1W 25K CR (Korean)
		x		**PMUF1160_	MTP700 Super Tanapa 806-870 MHz 1W 25K ES (Korean)
x				**PMUF1161_	MTP700 Super Tanapa 806-870 MHz 1W 25K CR-TEA1 (Chinese)
		x		**PMUF1162_	MTP700 Super Tanapa 806-870 MHz 1W 25K ES-TEA1 (Chinese)
x				**PMUF1163_	MTP700 Super Tanapa 806-870 MHz 1W 25K CR-TEA1 (Korean)
		x		**PMUF1164_	MTP700 Super Tanapa 806-870 MHz 1W 25K ES-TEA1 (Korean)
x	x			**PMUF1102_	***MTP700 Tanapa 806-870 MHz 1W 25K CR
		x	x	**PMUF1079_	***MTP700 Tanapa 806-870 MHz 1W 25K ES
x				**PMUF1116_	MTP700 Tanapa 806-870 MHz 1W 25K ES
		x		**PMUF1165_	MTP700 Tanapa 806-870 MHz 1W 25K ES (Chinese)
x				**PMUF1166_	MTP700 Tanapa 806-870 MHz 1W 25K CR (Chinese)
		x		**PMUF1167_	MTP700 Tanapa 806-870 MHz 1W 25K ES (Korean)
x				**PMUF1168_	MTP700 Tanapa 806-870 MHz 1W 25K CR (Korean)
		x		PMHF4000_	Back Chassis Kit 806-870 Mhz 1W 25W ES
x				PMHF4001_	Back Chassis Kit 806-870 Mhz 1W 25W CR
x				PMHN4048_	MTP700 Front Housing Kit CR (English/Chinese)
x				PMHN4049_	MTP700 Front Housing Kit CR (English/Korean)
x	x			PMHN4038_	MTP700 Front Housing Kit CR
		x	x	PMHN4039_	MTP700 Front Housing Kit ES
x				PMHN4040_	MTP700 Front Housing Kit ES

<b>MTP700, 806-870 MHz (Continued)</b>					
<b>Model</b>					<b>Description</b>
H47XCM6TZ5AK					MTP700 806-870 MHz 1W 25K ES PT711E (Korea)
H47XCM6TZ6AN					MTP700 806-870 MHz 1W 25K CR PT711E
*H47XCM6TZ6AB					MTP700 806-870 MHz 1W 25K CR PT711E
H47XCM6TZ5AN					MTP700 806-870 MHz 1W 25K ES PT711E
*H47XCM6TZ5AB					MTP700 806-870 MHz 1W 25K ES PT711E
				<b>Item</b>	<b>Description</b>
			x	PMHN4050_	MTP700 Front Housing Kit ES (English/Chinese)
			x	PMHN4051_	MTP700 Front Housing Kit ES (English/Korean)
	x	x	x	NAF5037_	1/2 Wave Whip Antenna 806-870 MHz
x	x	x	x	NAF5042_R	1/4 Wave Stubby Antenna 806-870 MHz
x	x	x	x	6804113J89	MTP700 User Guide (English)
	x	x	x	6804113J87	MTP700 User Guide (Traditional Chinese)
	x	x	x	6804112J75	MTP700 User Guide (Simplified Chinese)
x	x	x	x	6804113J42	MTP700 User Guide (Korean)

**Note:**

- x Indicates one of each is required.
- \* For Asia, please use H415EK Option for Bulk Package.
- \*\* For replacement kits, see Appendix A Replacement Parts and Kits.
- \*\*\* Not Field Replaceable for Latin America

## MTP750 Portable Radio Model Charts

<b>MTP750, 380-430 MHz</b>		
<b>Model</b>	<b>Description</b>	
*H76QCM6TZ5AN	MTP750 380-430 MHz 1W 25K ES PT911EE	
x	**PMUE2128_	MTP750 Super Tanapa 380-430 MHz 1W 25K ES
x	**PMUE2129_	MTP750 Super Tanapa 380-430 MHz 1W 25K ES (Chinese)
x	**PMUE2176_	MTP750 Super Tanapa 380-430 MHz 1W 25K ES - TEA1
x	**PMUE2178_	MTP750 Super Tanapa 380-430 MHz 1W 25K ES - TEA1 (Chinese)
x	**PMUE2177_	MTP750 Super Tanapa 380-430 MHz 1W 25K ES - TEA3
x	**PMUE2179_	MTP750 Super Tanapa 380-430 MHz 1W 25K ES - TEA3 (Chinese)
x	**PMUE2122_	MTP750 Tanapa 380-430 MHz 1W 25K ES
x	**PMUE2123_	MTP750 Tanapa 380-430 MHz 1W 25K ES (Chinese)
x	PMHE4029_	Back Chassis Kit 380-430 MHz 1W 25K ES
x	PMHN4055_	MTP750 Front Housing Kit ES (English)
x	PMHN4056_	MTP750 Front Housing Kit ES (Chinese)
x	FAE6000_	Narrow Band Antenna 380-400 MHz
x	NAE6546_R	Narrow Band Antenna 410-430 MHz
x	FAE5520_	Whip Antenna 380-400 MHz
x	NAE6549_R	Whip Antenna 410-430 MHz
x	6804113J81	MTP750 Basic User Guide (English/Simplified Chinese)
x	6804113J91	MTP750 Basic User Guide (English/Traditional Chinese)
x	6804113J82	MTP750 Full Feature User Guide (English)
x	6804113J83	MTP750 Full Feature User Guide (Traditional Chinese)
x	6804113J97	MTP750 Full Feature User Guide (Simplified Chinese)

Note:

- x Indicates one of each is required.
- \* For Asia, please use H415EK Option for Bulk Package.
- \*\* For replacement kits, see Appendix A Replacement Parts and Kits.
- \*\*\* Not Field Replaceable for Latin America

<b>MTP750, 806-870 MHz</b>	
<b>Model</b>	<b>Description</b>
*H76XCM6TZ5AN	MTP750 806-870 MHz 1W 25K ES PT711EE
<b>Item</b>	<b>Description</b>
x **PMUF1179_	MTP750 Super Tanapa 806-870 MHz 1W 25K ES
x **PMUF1180_	MTP750 Super Tanapa 806-870 MHz 1W 25K ES (Chinese)
x **PMUF1182_	MTP750 Super Tanapa 806-870 MHz 1W 25K ES - TEA1
x **PMUF1183_	MTP750 Super Tanapa 806-870 MHz 1W 25K ES - TEA1 (Chinese)
x **PMUF1184_	MTP750 Super Tanapa 806-870 MHz 1W 25K ES - TEA3
x **PMUF1185_	MTP750 Super Tanapa 806-870 MHz 1W 25K ES - TEA3 (Chinese)
x **PMUF1173_	MTP750 Tanapa 806-870 MHz 1W 25K ES
x **PMUF1174_	MTP750 Tanapa 806-870 MHz 1W 25K ES (Chinese)
x PMHF4008_	Back Chassis Kit 806-870 Mhz 1W 25W ES
x PMHN4055_	MTP750 Front Housing Kit ES (English)
x PMHN4056_	MTP750 Front Housing Kit ES (Chinese)
x NAF5037_	1/2 Wave Whip Antenna 806-870 MHz
x NAF5042_R	1/4 Wave Stubby Antenna 806-870 MHz
x 6804113J81	MTP750 Basic User Guide (English/Simplified Chinese)
x 6804113J91	MTP750 Basic User Guide (English/Traditional Chinese)
x 6804113J82	MTP750 Full Feature User Guide (English)
x 6804113J83	MTP750 Full Feature User Guide (Traditional Chinese)
x 6804113J97	MTP750 Full Feature User Guide (Simplified Chinese)

## Note:

- x Indicates one of each is required.
- \* For Asia, please use H415EK Option for Bulk Package.
- \*\* For replacement kits, see Appendix A Replacement Parts and Kits.
- \*\*\* Not Field Replaceable for Latin America



## MTP700/MTP750 Portable Radio Model Information

Model	Model Description
P1	MTP700 <b>380-430 MHz</b> , 1 W, 25 kHz, with <b>Continuous Rotary</b> knob for group selection (CR)
P2	MTP700 & MTP750 <b>380-430 MHz</b> , 1 W, 25 kHz, with <b>End Stop</b> knob for group selection (ES)
P3	MTP700 <b>806-870 MHz</b> , 1 W, 25 kHz, with <b>Continuous Rotary</b> knob for group selection (CR)
P4	MTP700 & MTP750 <b>806-870 MHz</b> , 1 W, 25 kHz, with <b>End Stop</b> knob for group selection (ES)
P5	MTP700, <b>806-870 MHz</b> , 1 W, 25 kHz, with <b>End Stop</b> knob for group selection (ES), Korean model

### Sales Model Nomenclature

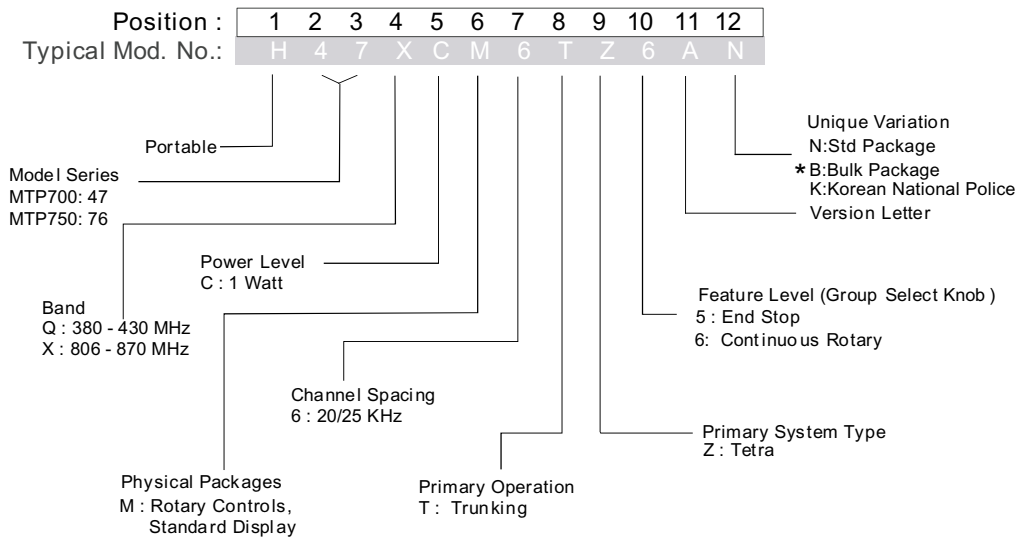

\* For Asia, please use H415EK Option for Bulk Package.

## MTP700/MTP750 Portable Radio Model Specification

GENERAL		RECEIVER		TRANSMITTER	
ETSI:	ETS 300 394-1	Receiver Type:	Class B	Modulation Type:	$\pi/4$ DQPSK
Type Number (MPT700)		Frequency Range:		Nomin. Output Power:	
- 380-430 MHz:	PT911E	- TMO:	380-430 MHz	- TMO	30 dBm
- 806-870 MHz:	PT711E		851-870 MHz	- DMO	30 dBm
Type Number (MPT750)		- DMO:	380-430 MHz	Frequency Range:	
- 380-430 MHz:	PT911EE		851-870 MHz	- TMO:	380-430 MHz
- 806-870 MHz:	PT711EE			- DMO:	380-430 MHz 851-870 MHz
Temperature:		Channel Spacing:	25 kHz	Channel Spacing:	25 kHz
- Operating Temp.:	-30... +60°C (except Lilon battery & LCD display: -20°C)	Sensitivity (4%) BER:	-112 dBm (minimum)		
- Storage Temp.:	-40... +85°C				
Battery chemistries:	Lilon or NiMh	Intermodulation:	-47 dBm	Spurious Emission:	-36 dBm
Battery capacity:		Blocking:		Adjacent Channel Power (at $\pm 25$ kHz)	-55 dBc (UHF)
- with standard Lilon:	1500 mAh	- at 1, 2, 5 & 10 MHz	-25 dBm		
- with NiMh:	1200 mAh	- Adjacent channel selectivity @ 25 kHz	-60 dBm		
Battery autonomy 5/5/90 (TX/RX/Stdby):				Spurious Rejection:	-45 dBm
- with standard Lilon or NiMh	23 hours*			Frequency Stability:	
				- TMO	$\pm 100$ Hz relative to downlink carrier frequency
				- DMO	$\pm 1$ kHz
Battery autonomy 5/35/60 (TX/RX/Stdby):		Audio Rated:	500 mWatt		
- with standard Lilon or NiMh	15 hours*	Distortion:	< 5 %		
Dimensions (HxWxD) mm:	143x55x39				
Weight:					
- with standard Lilon battery	367 g				
- with standard NiMh battery	434 g				

\* at medium audio power level

**Table 2-1** Model Specification

## MTP700/MTP750 Accessories-To-Model Chart

MTP700/MTP750 PORTABLE RADIO ACCESSORIES	Kit Number	380-430 MHz		806-870 MHz		
		P1	P2	P3	P4	P5
<b>Batteries - Smart</b>	<b>Kit Number</b>	<b>P1</b>	<b>P2</b>	<b>P3</b>	<b>P4</b>	<b>P5</b>
Battery, Lilon, Std, 1200 mAh	PMNN4047_	x	x	x	x	x
Battery, NiMH, 1200 mAh	PMNN4048_	x	x	x	x	
Battery, NiMh, FM, 1150 mAh	PMNN4049_	x	x	x	x	
<b>Antennae</b>	<b>Kit Number</b>	<b>P1</b>	<b>P2</b>	<b>P3</b>	<b>P4</b>	<b>P5</b>
806-870 MHz, Whip	NAF5037_			x	x	
806-870 MHz, Stubby	NAF5042_R			x	x	x
380-400 MHz, Narrow band	FAE6000_	x	x			
410-430 MHz, Narrow band	FAE6001_/NAE6546_R	x	x			
380-400 MHz, Whip	FAE5520_	x	x			
410-430 MHz, Whip	FAE6002_/NAE6549_R	x	x			
<b>Chargers</b>	<b>Kit Number</b>	<b>P1</b>	<b>P2</b>	<b>P3</b>	<b>P4</b>	<b>P5</b>
IMPRES Multi Unit Charger (MUC) with 110 US Plug	WPLN4108_	x	x	x	x	
IMPRES Multi Unit Charger (MUC) with 230V Euro Plug	WPLN4109_	x	x	x	x	
IMPRES Multi Unit Charger (MUC) with 230V UK Plug	WPLN4110_	x	x	x	x	
IMPRES Multi Unit Charger (MUC) with 120V USA Plug	WPLN4120_	x	x	x	x	
IMPRES Display Multi Unit Charger (MUC), 110-230V US Cord	WPLN4135_	x	x	x	x	
IMPRES Display Multi Unit Charger (MUC), 110-230V EU Cord	WPLN4131_	x	x	x	x	
IMPRES Display Multi Unit Charger (MUC), 110-230V UK Cord	WPLN4132_	x	x	x	x	
IMPRES Display Multi Unit Charger (MUC), 110-230V Korea Cord	WPLN4136_					x
Display Module	RLN5382_	x	x	x	x	x
Battery Insert (all MUCs need this battery adapter)	RLN5212_	x	x	x	x	
110V Single Unit Charger (SUC) Smart Charger	WPLN4111_R	x	x	x	x	
IMPRES Single Unit Charger (SUC) with Euro Plug	WPLN4112_	x	x	x	x	
IMPRES Single Unit Charger (SUC) with UK Plug	WPLN4113_	x	x	x	x	
IMPRES Single Unit Charger (SUC) with AUST/ NZ Plug	WPLN4115_	x	x	x	x	
IMPRES Single Unit Charger (SUC) with Argentina Plug	WPLN4116_	x	x	x	x	
Single Unit Adaptive Charger (SUC) with US/NA Plug	WPLN4117_R	x	x	x	x	
IMPRES Lite Single Unit Charger (SUC), 110V US Plug	AZWPLN4149_	x	x	x	x	
IMPRES Lite Single Unit Charger (SUC), 230V EU Plug	AZWPLN4150_	x	x	x	x	
IMPRES Lite Single Unit Charger (SUC), 230V UK Plug	AZWPLN4151_	x	x	x	x	
IMPRES Lite Single Unit Charger Base	WPLN4148_	x	x	x	x	
Battery Insert (all SUCs need this battery adapter)	RLN5211_	x	x	x	x	
Rapid Charger, Non-Smart, US Plug 2-Pin*	PMTN4063_	x	x	x	x	
Rapid Charger, Non-Smart, Euro Plug 2-Pin*	PMTN4064_	x	x	x	x	
Rapid Charger, Non-Smart, UK Plug 3-Pin*	PMTN4065_	x	x	x	x	
Charger Base only - Non-Smart*	PMLN4522_	x	x	x	x	x
Travel Charger	GMLN1027_	x	x	x	x	x
Vehicle Adapter (order via COF only due to options required)	GMLN1040_	x	x	x	x	x

Table 2-2 Accessories

MTP700/MTP750 PORTABLE RADIO ACCESSORIES		380-430 MHz		806-870 MHz		
Carrying Case Accessories	Kit Number	P1	P2	P3	P4	P5
Hard leather case with Swivel	PMLN4474_	x	x	x	x	x
Carrying strap for above	NTN5243_	x	x	x	x	x
2.5 inch belt clip	HLN9714_	x	x	x	x	x
Light leather case ("GSM" style)	PMLN4475_	x	x	x	x	
Wrist strap	HLN9767_	x	x	x	x	x
Nylon Case	RLN4851_	x	x	x	x	
Large Shoulder Harness Kit	GMLN4093_	x	x	x	x	
Small Shoulder Harness Kit	GMLN1051_	x	x	x	x	
AUDIO - REMOTE SPEAKER / MICROPHONE (RSM)	Kit Number	P1	P2	P3	P4	P5
Enhanced Remote Speaker/Microphone (ERSM), terminates with side connector, emergency button, programmable button, manual volume control, earpiece jack, vibrator alert	RMN5011_ (Short - 35cm) RMN5012_ (Long - 70 cm)	x	x	x	x	x
Short Coil Cord (35 cm)	RLN5258_	x	x	x	x	
Long Coil Cord (70 cm)	RLN5259_	x	x	x	x	
Remote Speaker/Microphone (RSM), with 3.5 mm threaded jack	RMN5013_	x	x	x	x	
Receive only earbud, black coiled cord (plugs into 3.5 mm jack on RSM)	RLN4885_	x	x	x	x	
3.5 mm Audio Accessory Adapter	HLN9717_	x	x	x	x	x
Programming Equipment	Kit Number	P1	P2	P3	P4	P5
Data Cable	PMLN4504_	x	x	x	x	x
Programming/Data Cable	FLN9636_	x	x	x	x	x
Programming Stand	PMLN4510_	x	x	x	x	x
MTP700 Customer Programming Software (CPS)	FVN5051_	x	x	x	x	x
Audio Surveillance	Kit Number	P1	P2	P3	P4	P5
Rx Only Earpiece - Black	AZRMN4028_	x	x	x	x	
Rx Only Earpiece - Beige	AZRMN4021_	x	x	x	x	
Rx Only Earpiece -with transparent tube for RSM	RLN4941_	x	x	x	x	
Earpiece with mic and PTT combined, beige, 2 wire	AZRMN4022_	x	x	x	x	x
Earpiece with mic and PTT combined, black, 2 wire	AZRMN4029_	x	x	x	x	
Earpiece with separate mic and PTT, beige, 3 wire	ENMN4017_	x	x	x	x	x
Earpiece with separate mic and PTT, black, 3 wire	ENMN4014_	x	x	x	x	
Earplugs Foam w/Acoustic Tube	NTN8370_	x	x	x	x	
Rubber Eartips w/Acoustic Tube	NTN8371_	x	x	x	x	
Noise Attenuating Plugs	5080384F72	x	x	x	x	
Large Earshell (offered in EMEA)	WADN4223_	x	x	x	x	
Small Earshell (offered in EMEA)	WADN4224_	x	x	x	x	
Audio - Headsets	Kit Number	P1	P2	P3	P4	P5
Lightweight Headset with Swivel Boom Microphone & PTT	RMN5014_	x	x	x	x	
Breeze Headset, PTT	ENMN4012_	x	x	x	x	

Table 2-2 Accessories

\* For Asia only.

## CHAPTER 3 OVERVIEW

---

### General

The MTP700/MTP750 is Motorola's latest and most advanced digital portable TETRA radio. This radio generation is based on a new digital platform technology. It covers Trunk Mode Operation (TMO) as well as Direct Mode Operation (DMO) and among other new features it is supplied with extended code and operation memory capacity to support all new market requirements. The TETRA radios ensure a high audio quality.

To achieve a high spectrum efficiency, the radio units use digital modulation technology and sophisticated voice-compression algorithm. The voice of the person speaking into the microphone is converted into a digital bit stream consisting of zeros (0) and ones (1). This stream is then modulated into a radio-frequency (RF) signal, which is transmitted over the air to another unit. This process is called digital modulation.

---

### Digital Modulation Technology

The MTP700/MTP750 are 380-430 MHz or 806-870 MHz portable radios that can operate in dispatch mode. They use two digital technologies:  $\Pi/4$  DQPSK and Time Division Multiple Access (TDMA).

$\Pi/4$  DQPSK is a modulation technique that transmits information by altering the phase of the radio frequency (RF) signal. Data is converted into complex symbols, which alter the RF signal and transmit the information. When the signal is received, the change in phase is converted back into symbols and then into the original data.

The TETRA system can accommodate 4-voice channels in the standard 25 kHz channel as used in the two-way radio.

Time Division Multiple Access (TDMA) is used to allocate portions of the RF signal by dividing time into four slots, one for each unit.

Time allocation enables each unit to transmit its voice information without interference from other transmitting units. Transmission from a unit or base station is accommodated in time-slot lengths of 14 milliseconds and frame lengths of 57 milliseconds. The TDMA technique requires sophisticated algorithms and voice compressions/decompressions (perform by digital-signal processor, DSP) and RF modulation/demodulation.

### Voice Compression Technology

Voice is converted into a digital bit stream by sampling the voice at a high rate and converting the samples into numbers, which are represented by bits.

Voice compression reduces the number of bits per second while maintaining the voice at an acceptable quality level. The TETRA system uses a coding technique called ACELP (Algebraic Code Excited Linear Prediction). The compressed voice-data bits modulate the RF signal.

**THIS PAGE INTENTIONALLY LEFT BLANK**

## CHAPTER 4

# PROGRAMMING THE RADIO

### Before Using the Customer Programming Software (CPS)

Before you begin programming, ensure the following:

1. Install the Customer Programming Software (CPS), FVN5051A, in your computer.
2. Use a fully charged radio battery.
3. With the radio initially turned off, properly place radio into Programming Stand, PMLN4510.
4. Connect the Programming/Data cable, FLN9636, according to Setup for Radio Programming Figure 4-1. This cable has a switch with two positions "Data" and "Flash". Set the switch to "Flash" to enable programming.
5. Turn radio on by rotating the On/Off knob clockwise. Verify that no display appears on the radio LCD screen.

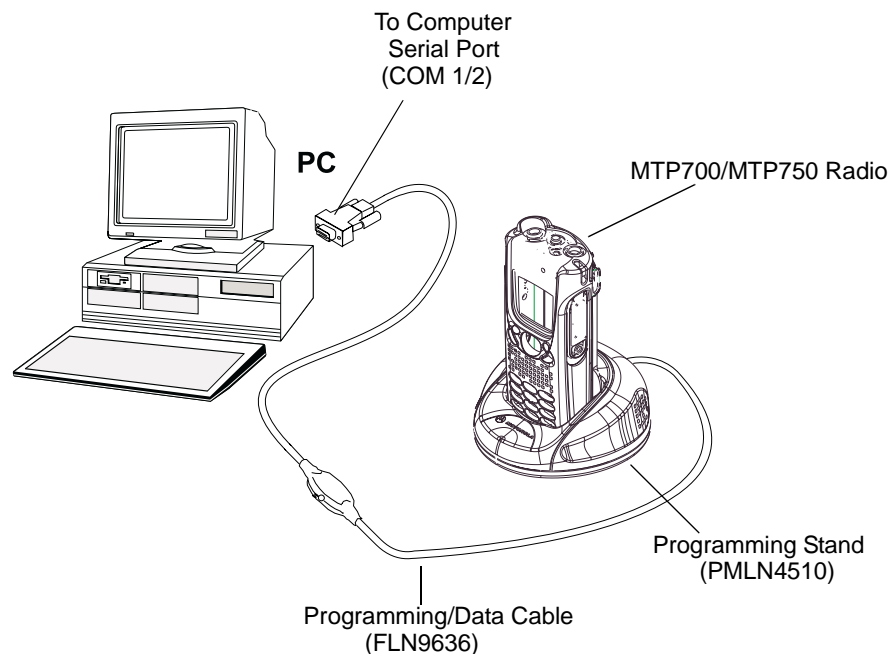

**Figure 4-1** Setup for Radio Programming.

---

## Reading Codeplug

1. Run the Customer Programming Software (CPS) on your computer.
2. Click the Toolbar “Read Phone” icon. *Refer to the CPS Application Window Screen in the CPS User Guide, Publication No. 68P02956C20.* The setup enters an initialization process that takes about 20 seconds. After that, a reading process starts.

**Note:** While reading is in progress, the radio screen displays the following data:

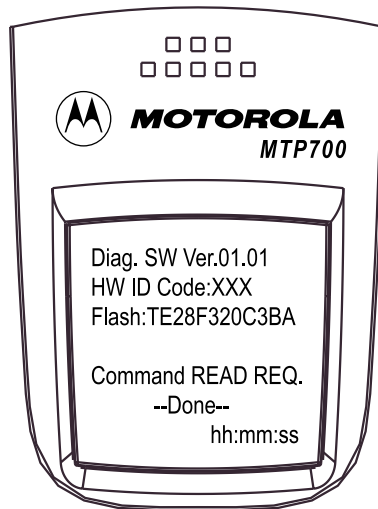

A progress bar appears on the computer screen. After the reading process is finished, the radio Codeplug screen appears.

---

## Programming Codeplug

1. On the menu bar, click “File”, “Open”.
2. Browse for the required Codeplug file and open the file (.dbf extension).
3. The Codeplug window appears on the screen.
4. Click the Toolbar “Write Phone” icon.

**Note:** The Codeplug is now being written into the radio. A progress bar is displayed on the computer screen showing the writing status.  
After a successful writing, the message “The Operation Was Successful” appears on the computer screen.

5. Press the “OK” button.



## Programming Frequency

Carry out the following steps if you need to add or change the radio frequencies.

**Note:** Save your radio factory frequencies before you start programming by using “File”, “Save As”. Give the file a proper name, eg “default.dbf”.

1. In the “Codeplug Tree” select “System Parameters”.
  - Click on “Frequency List”.
  - Click on “List2”.
  - At the top of list, enter the three frequencies which you have selected (the following frequencies are for example only):

Rx 420.0125MHz (IFR 800)

Rx 425.0125MHz (IFR 1000)

Rx 429.9875MHz (IFR 1199)

2. Click the Toolbar “Write Phone” icon.
3. Disconnect the radio from the programming kit.

**Note:** The new programmed frequencies of the radio are now available to be tested with the IFR or for any other use.

“List2” frequencies are saved on the codeplug and may only be accessed in Test Page mode. To go into Test Page (feature must be turned on in CPS i.e. “User Personal Data\Ergonomic Parameters\Feature Flags\Test Page” checked on), perform steps **4** thru **7** by pressing the radio keys sequentially (less than a second between every consecutive press):

4. *Press the “Side Button 2” key.*
5. *Press the “1” key, and “Menu” key.*
6. *Press the “2” key, and “Menu” key.*
7. *Press the “3” key.*

Hereafter, there is no need for quick sequence of pressing the radio keys.

8. Scroll through the list and select “Cell Lists”.
9. Press the “OK” key.
10. Scroll through the list. Select “List2”.
11. Press the “OK” key.
12. View the frequencies using the arrow navigation keys.

## Restoring Factory Frequencies of the Radio

To restore the factory frequencies of the radio, perform the following steps:

1. After testing your radio on the IFR, connect the setup as shown in Figure 4-1.
2. Run the CPS software on your PC.
3. In the menu bar click "Tools", "Copy Wizard".
  - Click on "Read from a file".
  - Click on "Browse".
  - Open the file which contains the default factory frequencies (ie "default.dbf" file which you saved in "Programming Factory" section earlier).
  - Click on "Next".
  - Click on "Select All".
  - Click on "Next".
  - Click on "Write".
  - Click on "Done".

**Note:** Click on toolbar "Read Phone" to check whether the same factory frequencies were entered into the radio before programming.

---

## Programming Firmware

**Note:** Login as "Administrator" to perform this task.

1. On the menu bar click "Tools", "Write Software".

**Note:** The CPS reads data from the radio. A progress bar is displayed on the computer screen showing the reading status.  
After a successful reading, the "Write Software To Phone" window appears on the computer screen.

2. Press the "Write" button.

**Note:** The application is now being written into the radio. A progress bar is displayed on the computer screen showing the writing status.  
After a successful writing, the message "The Operation Was Successful" appears on the computer screen.

3. Press the "OK" button.
4. Click the Toolbar "R" (Reset) icon to put radio into normal operating mode.

---

## Manual Mode Testing

---

### Preparation for Testing

1. Verify that the radio is turned off.
2. Press the “1”, “2” and “3” keys together and turn the On/Off knob clockwise to turn the radio on.
3. The display shows “LCD Test Press Any Key To Proceed”.

---

### Tests

**Note:** Any key that will be pressed will cause the test to advance from one step to the next.

---

### LCD Display Test

1. Press any key consecutively. The display shows horizontal lines that becomes thicker with every key press, until it becomes fully dark.
2. Press any key again, the following appears at the top of the display:



3. Press any key consecutively. The display shows vertical lines that becomes thicker with every key press, until it becomes fully dark.
4. Press any key again. The display shows the Motorola logo.
5. Press any key again. The display shows “Vibrator On”. You will need to have an external Smart RSM (RMN5011\_ or RMN5012\_) to verify that the radio is vibrating.
6. Press any key again. The display shows “Red Led On” and the Red LED at the top of the radio is constantly lit.
7. Press any key again. The display shows “Green Led On” and the Green LED at the top of the radio is constantly lit.
8. Press any key again. The display shows “Both Leds On” and the amber LED at the top of the radio is flashing.
9. Press any key again. The display shows “Backlight On” and the display and keypad backlight are both on.

10. Press any key again. The display shows "Speaker Tone Test", a tone is heard via the speaker.
11. Press any key again. The display shows "Earpiece Tone Test", a tone is heard via the earpiece.
12. Press any key again. The display shows "Audio Loopback Test", speak into the microphone, you should hear your voice via the earpiece.
13. Press any key again. The display shows "Chopper-Noise Test 1", a low hum must not be heard via the earpiece.
14. Press any key again. The display shows "Chopper-Noise Test 2", a low hum must not be heard via the earpiece.
15. Press any key again. The display shows the "Rotary Knob Test" map.
16. Rotate the talkgroup knob from location "1" until "16" and make sure at each location the corresponding number disappears from the display.
17. The display proceeds to show all the radio keys, knobs and buttons.
18. Press every radio item one by one. Each item you press causes its respective display to disappear.
19. The display then shows "Press any key to Continue".
20. Pressing any key will cause display to show a series of "\*", "<" and ">" characters.
21. Press the Top Navigation key until all top four "\*" characters disappear.
22. Press the Bottom Navigation key until all bottom four "\*" characters disappear.
23. Press the Left Navigation key until all left four "<" characters disappear.
24. Press the Right Navigation key until all right four ">" characters disappear.
25. After pressing all keys, the display is clear.
26. Turn the radio Off.

## CHAPTER 5 TEST SETUP & TESTING



### WARNING

Any level 3 repairs can deeply affect the performance of the radio and may cause a new tuning procedure.

This tuning procedure can only be applied by certain authorised Motorola depots where the appropriate TEST & TUNE EQUIPMENT is available.

The appropriate TEST & TUNE EQUIPMENT is a special automated test equipment which is only available at some Motorola factories and Motorola repair centers.

### Typical Test Setup

#### Before Testing

Carry out the following instructions before testing:

- Check that you have a fully charged battery (not required when using Battery Eliminator).
- Insufficient battery supply may cause firmware or codeplug corruption during programming.
- Connect an RF cable to the N-type RF Connector of the IFR.
- Connect the other side of the RF cable to the antenna connector on the radio using a SMA type RF connector.

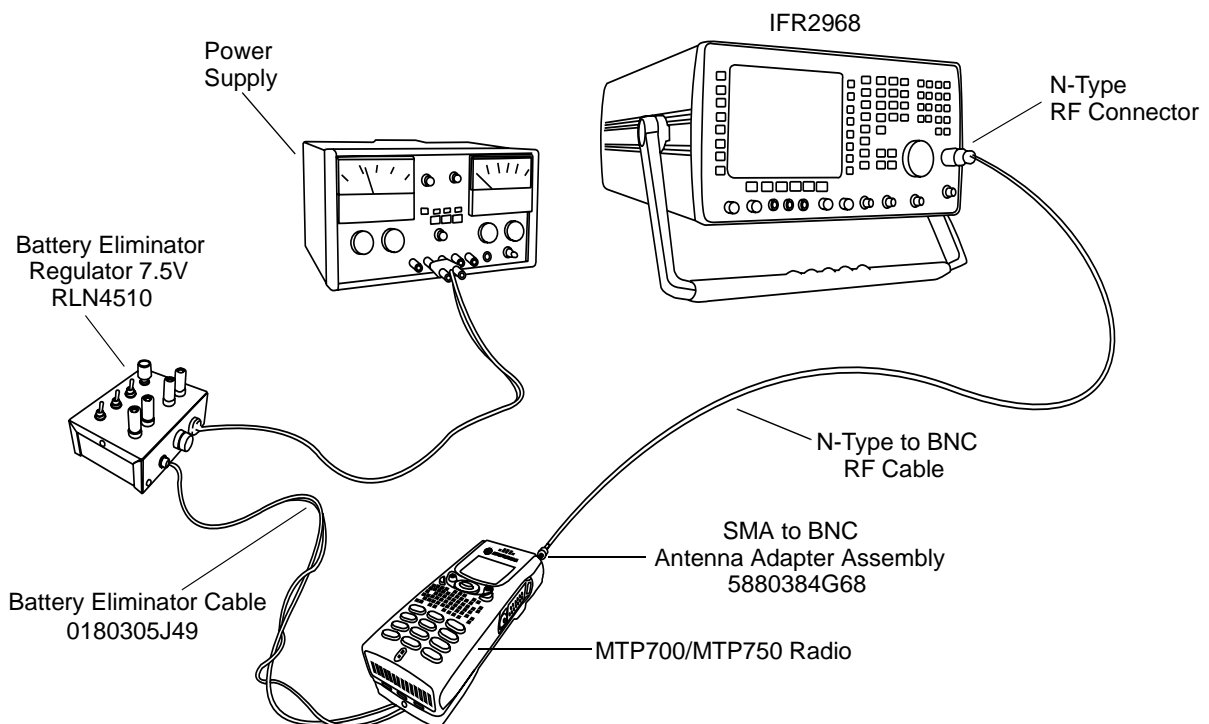

Figure 5-1 Typical Test Setup

## Test Equipment

The table below lists the special test equipment required for servicing TETRA Portable Radios.

<b>Motorola Part No.</b>	<b>Description</b>
WADN4161A*	TETRA SERVICE MONITOR, MOBILES ONLY
WADN4163A	TETRA SERVICE MONITOR, MOBILES AND DIRECT MODE
WADN4164A	TETRA SERVICE MONITOR, MOBILES AND BASE STATIONS
WADN4173A	TETRA SERVICE MONITOR, MOBILES, DIRECT MODE AND BASE STATIONS
WADN4233A	TETRA SERVICE MONITOR, MOBILES, DIRECT MODE AND MPT1327/1343

NOTE:\* WADN4161A is the minimum required for testing TETRA Radios

## Test Check List

The following table summarises the required test setups.

**Note:** Values for 380-430 MHz radio in brackets [ ].

No.	Test Name	Test Setup	Radio Setup	Test Conditions	Limits
1.	Base Station Registration	Control Channel	861.0125MHz [ 420.0125MHz ]	2440 [ 800 ]	
		Traffic Channel		2140 [ 800 ]	
		Time Slot		3	
		Country Code		753 [ 234 ]	
		Network Code		2361 [ 75 ]	
		Base Color		1	
		Location Area		22 [ 0000 ]	
		Min Rx Level			-110dBm
		Max Tx Level			30dBm
		Access Parameter			-53dBm
		Mobile Power	30dBm		
		Burst Type		Normal	
2.	Receiver RSSI	RF Gen Level	Test Page Cells Info RSSI Trace	-50dBm	
3.	Transmitter Tests	RF Gen Level	Group Mode	-90dBm	
		Burst Power			28-31.5dBm
		Timing Error			<=0.25 Symbols
		Frequency Error			-/+ 80Hz
		Vector Error			Max 10% RMS, Max 30% Peak, Max 5% Residual
4.	Call Processing Talk Back	RF Gen Level 1 kHz Test Signal	Group Mode	-90dBm	
5.	Call Processing Call to Mobile	RF Gen Level Private Call	Private Mode	-90dBm	
		Burst Power			28-31.5dBm
		Timing Error			<=0.25 Symbols
		Frequency Error			-/+ 80Hz
		Vector Error			Max 10% RMS, Max 30% Peak, Max 5% Residual

No.	Test Name	Test Setup	Radio Setup	Test Conditions	Limits
6.	Digital Duplex Test (Tx)	RF Gen Level	Private/Phone Mode 4 digit random number & "Send"	-90dBm	
		Burst Power			28-31.5dBm
		Timing Error			<=0.25 Symbols
		Frequency Error			-/+ 80Hz
		Vector Error			Max 10% RMS, Max 30% Peak, Max 5% Residual

### Receiver Tests

1. Simulate Base Station (registration)
2. RSSI

### Transmitter Tests

1. Power Profiles
2. Power Burst (Control Range)
3. Tx Burst Timing Error
4. Tx Frequency Error
5. Vector Error RMS, Peak and Residual

### Call Processing Tests

1. Talk Back
2. Call to Mobile

### Duplex Test

1. Digital Duplex Test (Tx)

Measurement Capabilities:

Bar chart display for Rx BER, Tx Power, Frequency Error, Vector Error RMS, Power analyser, Spectrum analyser, Vector analyser, Vector Diagrams.



## How to Configure the IFR 2968 System Setup

The setup depends on the firmware version of the IFR2968, the firmware version of the radio and the customer programming of the radio. The following steps should be taken only as an example of how to proceed for setup.

Perform the following steps to configure the IFR 2968 System Setup with the radio set.

**Note:** Terms for 380-430 MHz radio in brackets [ ]:

1. Turn ON the IFR.
2. Press "Systems" mode key (wait until the digital system is initialised).
3. Press the "TETRA Mobile" soft key.
4. Press the "Set-Up" soft key and enter the System Parameters Screen.
5. Press the "Channel Plan" soft key.
6. Press "More" soft key if "TETRA 800MS" ["TETRA 410MS"] cannot be seen.
7. Press "TETRA 800MS" soft key. The "Control Channel" automatically changes to "2440" ["800"] and "Traffic Channel" automatically changes to "2140" ["800"].
8. Press twice the "Traffic Channel" soft key and check that the marker goes to Timeslot. Press Data key "3" followed by the "Traffic Channel" soft key, to change to Timeslot "3".
9. Press "Country Code" soft key. Enter "753" ["234"] and "Country Code" soft key.
10. Press "Network Code" soft key. Thereafter, enter "2361" ["75"] and press "Network Code" soft key.
11. Press "Base Color" soft key. Thereafter, enter "1" and press "Base Color" soft key.
12. Press "Location Area" soft key. Thereafter, enter "22" ["0000"] and press "Location Area" soft key.
13. Press "More" soft key.
14. Press "Min Rx Level" soft key. Thereafter, enter "-110dBm" and press "Min Rx Level" soft key.
15. Press "Max Tx Level" soft key. Thereafter, enter "30dBm" and press "Max Tx Level" soft key.
16. Press "Access Parameter" soft key. Thereafter, enter "-53dBm" and press "Access Parameter" soft key.
17. Press "Test Mode" soft key. Press "Enable" soft key.
18. Press "Base Service" soft key.

19. Verify that the following values are displayed:

<b>POWER ON REGISTRATION:</b>	<b>REQUIRED</b>
<b>POWER OFF DE-REGISTRATION:</b>	<b>REQUIRED</b>
<b>PRIORITY CELL:</b>	<b>YES</b>
<b>MINIMUM MODE SERVICE:</b>	<b>NEVER USED</b>
<b>MIGRATION:</b>	<b>SUPPORTED</b>
<b>SYSTEM WIDE SERVICE:</b>	<b>NORMAL MODE</b>
<b>TETRA VOICE SERVICE:</b>	<b>SUPPORTED</b>
<b>CIRCUIT MODE DATA SERVICE:</b>	<b>SUPPORTED</b>
<b>(RESERVED):</b>	<b>NOT AVAILABLE</b>
<b>SND CP SERVICE:</b>	<b>AVAILABLE</b>
<b>AIR INTERFACE ENCRYPTION:</b>	<b>NOT AVAILABLE</b>
<b>ADVANCED LINK:</b>	<b>NOT SUPPORTED</b>

**Note:** The displayed values are factory defaults and should not be changed.

20. Press "Return" soft key.

21. Press the "Neighbor Cell" soft key.

22. Verify that the following values are displayed:

<b>NEIGHBOUR CELL BROADCAST:</b>	<b>NOT REQUIRED</b>
<b>BROADCAST INTERVAL:</b>	<b>10s</b>
<b>NEIGHBOUR CELL CHANNEL:</b>	<b>0000</b>
<b>NEIGHBOUR CELL LOCATION AREA:</b>	<b>00000</b>
<b>NEIGHBOUR CELL IDENTIFIER:</b>	<b>01</b>
<b>SLOW RE-SELECT THRESHOLD:</b>	<b>10dB</b>
<b>SLOW RE-SELECT HYSTERESIS:</b>	<b>10dB</b>
<b>FAST RE-SELECT THRESHOLD:</b>	<b>10dB</b>
<b>FAST RE-SELECT HYSTERESIS:</b>	<b>10dB</b>

**Note:** The displayed values are factory defaults and should not be changed.

23. Press the "Return" soft key.

24. Verify that "Trunking Type" is set to "Message".

25. Press "More" soft key.

26. Press the "Call Type" soft key to enter the "Call Type" screen.

27. Press "Private Call" soft key.

28. Press "Simplex Duplex" soft key and "Simplex Call" soft key.

29. Press "Signal Type" soft key and "Direct set –up" soft key.
30. Press "Priority" soft key. Thereafter, enter "00" and press the "Priority" soft key.
31. Leave "Calling Party SSI" setting to default value.
32. Press "Return" soft key.
33. Leave "Messages" setting to default value.
34. This completes the System Setup configuration.

---

## How to Configure the IFR 2968 Manual Test Screen

**Note:** Terms for 380-430 MHz radio in brackets [ ].

1. To enter Manual test screen, press "Manual" soft key.
2. Press "Control Channel" soft key. Thereafter, enter "2440" ["800"] and press "Control Channel" soft key (where IFR "2440" = Rx 861.0125MHz) [IFR "800" = Rx 420.0125MHz].
3. Press "Traffic Channel" soft key. Enter "2140" ["800"] and press "Traffic Channel" soft key. The marker goes to Timeslot. Enter "3" and press "Traffic Channel" soft key. (Note that the Traffic Channel number changes automatically after entering the Control Channel number).
4. Press "RF Gen Level" soft key and enter "-50". Then press the "dBm" or "RF Gen Level" soft key.
5. Press "Mobile Power" soft key followed by the appropriate "5dB step" soft key until "30 dBm/1W" is obtained. Then press "Return" soft key.
6. Press "Burst Type" soft key and "Normal" soft key. Then press "Return" soft key.
7. This completes the Manual test equipment configuration setup.

**Note:** The System Setup Configuration Data is saved even after the power is turned off. However, the Manual Test Setup is not saved.

---

## RF Tests

---

### Test Page

1. To set the radio into Test Page, perform the following sequence (feature must be turned on in CPS i.e. "User Personal Data\Ergonomic Parameters\Feature Flags\Test Page" checked on). When performing steps **2** thru **5**, make sure that you press the handset keys sequentially (less than a second between every consecutive press).
2. *Press the "Side Button 2" key.*
3. *Press the "1" key and "Menu" key.*
4. *Press the "2" key and "Menu" key.*
5. *Press the "3" key.*

Hereafter, there is no need for quick sequence of pressing the handset keys.

---

## Receiver Tests

### Simulate Base Station (Registration)

1. Make sure radio control channel frequency (IFR "2440" = Rx 861.0125MHz) [IFR "800" = Rx 420.0125MHz] is in List2 of radio. There are two ways to view List2:
  - a. via Test Page: When in Test Page, press "Down" navigation key to scroll to "Cell Lists", press "OK" using Right soft key. Then scroll down to "List2" and press "OK". Finally press "Right" navigation key and check that control channel frequency is enlisted.
  - b. via CPS: Go to "System Parameters\Frequency List/List2". Control channel frequency should be in the list.
2. Make sure Country Code "753" ["234"] and Network Code "2361" ["75"] is programmed in the radio. There are two ways to verify this:
  - a. via Test Page: When in Test Page, press "Down" navigation key to scroll to "Addresses", press "OK" using Right soft key. Press "OK" to select "Home MNI". You should see "2F1/939" ["EA/4B"] which is the hexadecimal equivalent of "753/2361" ["234/75"]. Press "Back" soft key until radio returns to normal/idle mode.
  - b. via CPS: Go to "System Parameters\Address Extension". "753" ["234"] and "2361" ["75"] should be found in the first row (ie as "Home" network).
3. Select "Home Only" as the registration network by following this procedure. Press "Menu" button and navigate down to "Networks". Press "OK" using Right soft key. Press "OK" to select "Networks Sel". Finally, scroll to "Home Only" and press the "Set" soft key.
4. Press "MCCH" followed by "Command Registrn" soft key at the bottom of the IFR.
5. Check that registration is successful and programmed radio SSI "ITSI: ---/----/00000100" (as example only) is displayed on the IFR "Manual Test" screen.

**Note:** "00000100" is the programmed Radio SSI.

6. In the event registration is unsuccessful, turn the radio OFF then ON again.

## RSSI Test

Before carrying out the following steps, record the Insertion loss (dB) of the cable loss value (denote as X dB). Also, 0.1 dB, the maximum insertion loss of the Antenna assembly adapter should be added to the total calculated insertion loss.

1. In the IFR Manual Test Mode, press the "RF Gen Level" soft key and enter "-50dbm".
2. Before testing, set the radio into Test Page and configure RSSI mode.
3. When in Test Page, press "Down" navigation key to enter the "Cells Info" state.
4. Press "OK" using the Right soft key.
5. Press "Down" navigation key to scroll to RSSI monitoring screen below.

**Note:** The display shows: **SERV: 16**  
**RSSI: -50**  
**SQE: 23**

Disregard the "SERV" and "SQE" results.

6. Press "Trace" using the Right soft key.
7. RSSI results will flash on the screen every few seconds.

Actual RSSI measured

= IFR RF Gen Level - (Antenna assembly adapter loss + Cable insertion loss) +/- other stray losses.

Range of Actual RSSI measured

= -50dBm - (0.1dB + XdB (cable)) +/- 3dB.

**The RSSI reading from the radio should be within the range of Actual RSSI given in formula above.**

8. To stop the "Trace" process, go into Test Page.
9. When in Test Page, press "Down" navigation key to enter the "Cells Info" state.
10. Press "OK" using the Right soft key.
11. Press "Stop" using the Right soft key.
12. Press "Back" using Left soft key until radio goes to normal/idle mode.

---

## Transmitter Tests

1. Change the "Mode" key of the radio to "Group Mode".
2. Press the "RF Gen Level" soft key and enter "-90dBm".
3. Press and hold the radio PTT and monitor the IFR "Manual Test" screen which displays the Power Profile, Burst Power, Timing Error, Frequency Error and Vector Error.

**Note:** You have to press and hold the PTT button long enough until the highlighted bars disappear from every parameter in IFR screen before reading the results.

- Power Profile:	<b>Passed.</b>
- Burst Power Required Results:	<b>28-31.5dbm.</b>
- Timing Error:	<b>≤ 0.25 symbols.</b>
- Frequency Error:	<b>-/+ 80Hz</b>
- Vector Error:	<b>Max 10% RMS Max 30% Peak Max 5% Residual</b>

4. Release the radio PTT.
5. Press the "Clear Down" soft key, to proceed with other tests.

---

## Call Processing Test

Before you start these tests, make sure that handset and test equipment are configured the same as given in the Transmitter Test.

### Talk Back

1. Change the "Mode" key of the radio to "Group Mode".
2. Press the "RF Gen Level" soft key and enter "-90dBm".
3. Press radio PTT and speak into the mic of the radio.
4. Press "Talkback" soft key. You will hear the last three seconds of the speech frames before the PTT is released.
5. Press the "Silence" soft key to mute the talkback audio.
6. Press the "Test Sound" soft key to provide the 1kHz signal to the radio speaker.
7. Press the "Silence" soft key to mute the 1KHz Audio Signal of the speaker.
8. Press the "Clear Down" soft key and check that the "Cleardown Complete" status appear on the IFR "Manual Test" screen.

## Call to Mobile

1. Press the radio "Mode" key and change to "Private" mode.
2. Press the "RF Gen Level" soft key and enter "-90dBm".
3. Press the "Call Mobile" soft key and select "Private Call" on the IFR. Verify that four beeps are heard from the speaker.
4. Press the "Abort Call" soft key.

---

## Duplex Test (Phone/Private Mode)

### Digital Duplex Test (Tx)

1. Press the "Mode" key of the radio and select either "Private" or "Phone" mode.
2. Dial a random 4 digit number (eg "9359") using the Alphanumeric keys of the radio and press the "Send" key.

The following results are displayed on the IFR "Manual Test" Screen.

**Note:** Read the measured parameters only when the highlighted bars disappear from every parameter in IFR screen.

- Power Profile:	Passed
- Burst Power Required Results:	28-31.5dbm
- Timing Error:	≤ 0.25 Symbols
- Frequency Error:	-/+ 80Hz
- Vector Error:	Max 10% RMS Max 30% Peak Max 5% Residual

3. Press the "Talkback" soft key.
4. Speak into the Handset Microphone and hear your speech (after a short delay) from the handset Earpiece.

**Note:** For more details, press the "Duplex Test" mode key.

Press the "Duplex Test (Tx)" soft key. The "Digital Duplex Test" results will be displayed on the IFR screen providing you with either one of the following:

- Bar charts measurement capabilities showing Tx Power, Frequency Error and Vector RMS in one screen, or
- Tx Power (more details in Power Analyser), or
- Frequency Error (more details in Spectrum Analyser), or
- Vector RMS (more details in Vector Analyser)

For Power Analyser Graph:

5. Press “power ana” soft key (the same button changes to “Bar Charts” soft key).
6. Check that the power frame falls within the limits.

For Spectrum Analyser Graph:

7. Press “spec ana” soft key (the same button changes to “Bar Charts” soft key).
8. Monitor the Tx frequency.

For Vector Analyser Diagram:

9. Press the “vector ana” soft key (the same button changes to “Bar Charts” soft key).
10. View the following:

- **Vector Error**
- **Magnitude Error**
- **Symbol Phase Error**

For Vector Diagram:

11. Press the “vector diagram” soft key (the same button changes to “Bar Charts” soft key).
12. Monitor the constellation diagram for the following:
  - **press “symbol constel” soft key for graphical symbol constellation.**
  - **press “rotated vector” soft key to zoom in on one of the constellations.**
  - **press “phase traject” soft key to view trajectory of the constellation.**
13. Press the handset “End” key.



---

## DMO Test

---

### IFR 2968 Test Setup

**Note:** Terms for 380-430 MHz radio in brackets [ ].

1. Press the "System" soft key.
2. Press "TETRA Direct" soft key.
3. Press "Setup" soft key.
4. Press "Channel Plan" soft key, press "TETRA870+ODM" [TETRA41ODM] for R2.
5. Press "DM Tx Mode" soft key, press "discontinue" soft key.

---

### How to Configure the IFR 2968 Manual Test Screen

1. Press the "Manual" soft key.
2. Press "Channel" soft key, thereafter enter "0600=870 MHz" [0882=412.0625 MHz] for R2 and press "Channel" soft key.
3. Press "Expected Power" soft key, enter 30.0 dBm/1.0 W.
4. Press "Burst Type" soft key and "Normal" soft key.

---

### Radio Configuration for DMO

Modify the radio for DMO option by carrying out the following sequence:

1. Turn ON the radio.
2. Press the "Menu" key.
3. Press the "Navigation" key and select mode "network", press "OK" soft key.
4. Select "OPERMODE", and press "OK" soft key.
5. Select "DIRECTMODE" soft key and press "OK" soft key.

## RF Test - Transmit Test

Hold the PTT in the pressed position long enough to enable you to read the results:

- Results: - Power Profile: Passed.
- Burst Power Request Results: 26-31 dBm.
- Frequency Error: 1 ppm max.
- Vector Error: Max. 10% RMS, Max. 30% Peak, Max. 5% Residual.

## Service Flow Chart

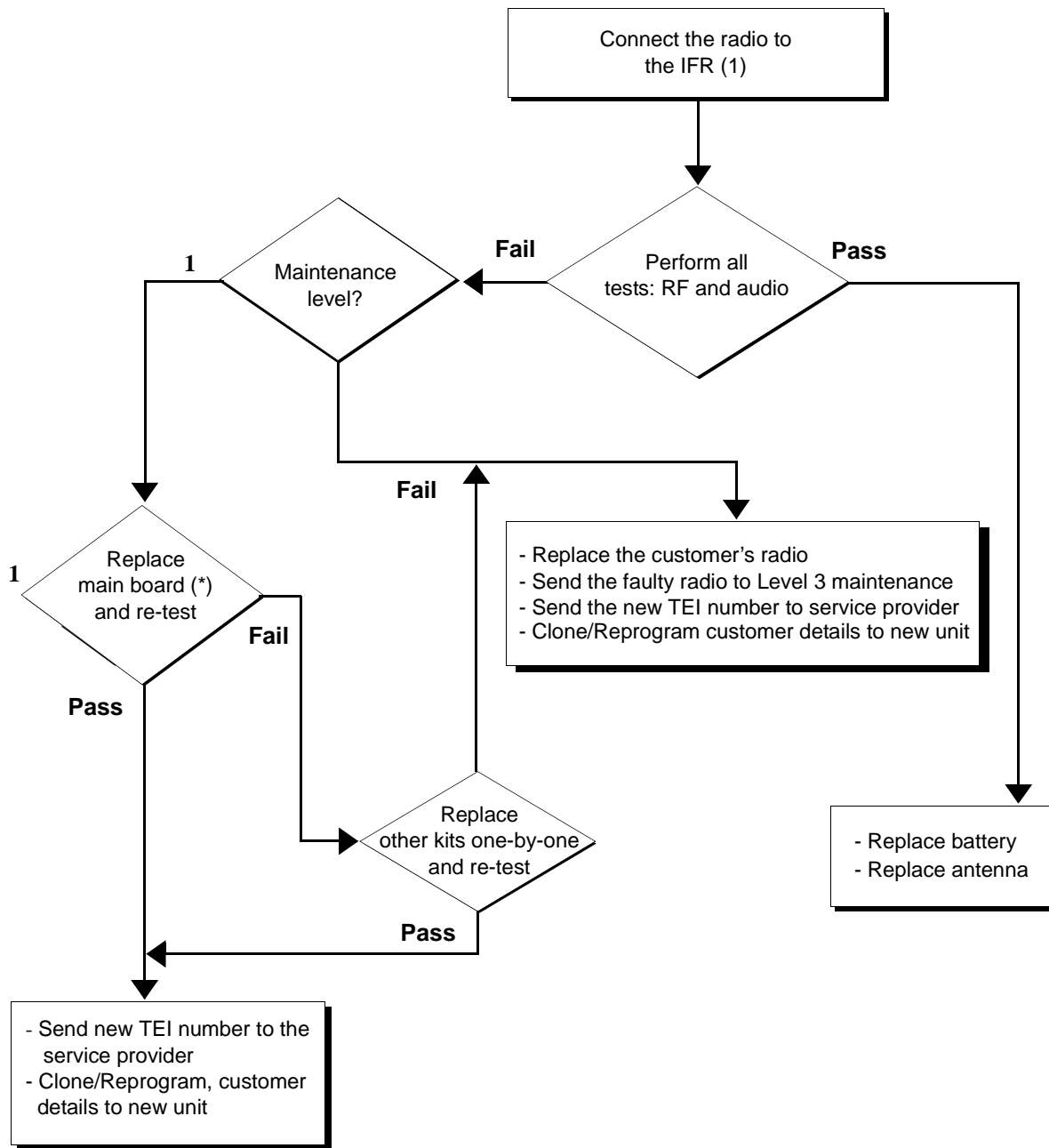

(\*) Refer to Appendix A  
Not Field Replaceable for Latin America

**THIS PAGE INTENTIONALLY LEFT BLANK**

# CHAPTER 6

## MAINTENANCE

### Introduction

This chapter provides details about the following:

- Preventive Maintenance (inspection and cleaning)
- Safe Handling of CMOS and LDMOS Devices
- Repair Procedures and Techniques
- Disassembly and Reassembly of the Radio

### Preventive Maintenance

#### Inspection

Check that the external surfaces of the radio are clean, and that all external controls and switches are functional. It is not recommended to inspect the interior electronic circuitry.

#### Cleaning Procedures

The following procedures describe the recommended cleaning agents and methods to be used when cleaning the external and internal surfaces of the radio. External surfaces should be cleaned whenever a periodic visual inspection reveals the presence of smudges, compound, or grime. Internal surfaces (circuit boards and components) should only be cleaned when the radio is disassembled for servicing or repair.

**NOTE** Internal surfaces should be cleaned only when the radio is disassembled for service or repair.

The only recommended agent for cleaning external radio surfaces is a 0.5% solution (one teaspoon of detergent per gallon of water) of mild dishwashing detergent in water. The internal surfaces should only be cleaned with isopropyl alcohol (70% by volume).



**CAUTION:** The effects of certain chemicals and their vapors can have harmful results on certain plastics. Avoid using aerosol sprays, tuner cleaners and other chemicals.

### Cleaning External Plastic Surfaces

Apply the 0.5% detergent-water solution sparingly with a stiff, non-metallic, short-bristled brush to work all loose dirt away from the radio. Use a soft, absorbent, lintless cloth or tissue to remove the solution and dry the radio. Make sure that no water remains entrapped near the connectors, cracks, or crevices.

### Cleaning Internal Circuit Boards and Components

Isopropyl alcohol (70%) may be applied with a stiff, non-metallic, short-bristled brush to dislodge embedded or caked materials located in hard-to-reach areas. The brush stroke should direct the dislodged material out and away from the inside of the radio. Make sure that controls or tunable components are not soaked with alcohol. Do not use high-pressure air to hasten the drying process since this could cause the liquid to collect in unwanted places. After completing of the cleaning process, use a soft, absorbent, lintless cloth to dry the area. Do not brush or apply any isopropyl alcohol to the frame, front cover, or back cover.

**NOTE** Always use a fresh supply of alcohol and a clean container to prevent contamination by dissolved material (from previous usage).

## Safe Handling of CMOS and LDMOS Devices

Complementary metal-oxide semiconductor (CMOS) devices are used in this family of radios, and are susceptible to damage by electrostatic or high voltage charges. Damage can be latent, resulting in failures occurring weeks or months later. Therefore, special precautions must be taken to prevent device damage during disassembly, troubleshooting, and repair.

Handling precautions are mandatory for CMOS circuits and are especially important in low humidity conditions. DO NOT attempt to disassemble the radio without first referring to the following CAUTION statement.



**CAUTION: This radio contains static-sensitive devices. Do not open the radio unless you are properly grounded. Take the following precautions when working on this unit:**

- Store and transport all CMOS devices in conductive material so that all exposed leads are shorted together. Do not insert CMOS devices into conventional plastic “snow” trays used for storage and transportation of other semiconductor devices.
- Ground the working surface of the service bench to protect the CMOS device. We recommend using the Motorola Static Protection Assembly (part number 0180386A82), which includes a wrist strap, two ground cords, a table mat, and a floor mat.
- Wear a conductive wrist strap in series with a 100k resistor to ground. (Replacement wrist straps that connect to the bench top covering are Motorola part number RSX-4015.)
- Do not wear nylon clothing while handling CMOS devices.
- Do not insert or remove CMOS devices with power applied. Check all power supplies used for testing CMOS devices to be certain that there are no voltage transients present.
- When straightening CMOS pins, provide ground straps for the apparatus used.
- When soldering, use a grounded soldering iron.
- If at all possible, handle CMOS devices by the package and not by the leads. Prior to touching the unit, touch an electrical ground to remove any static charge that you may have accumulated. The package and substrate may be electrically common. If so, the reaction of a discharge to the case would cause the same damage as touching the leads.

---

## Repair Procedures and Techniques — General

---

### Parts Replacement and Substitution

When damaged parts are replaced, identical parts should be used. If the identical replacement part is not locally available, check the parts list for the proper Motorola part number and order the part from the nearest Motorola Radio Support Center. For details, please refer to relevant Support Depots on page 1-3 to 1-5.

---

### Disassembling and Reassembling the Radio - General

Since these radios may be disassembled and reassembled with the use of only five (board to casting) screws, it is important to pay particular attention to the snaps and tabs and how parts align with each other.

The following tools are required for disassembling the radio:

- chassis opener (6686263Z02)
- flat-head, penknife-size screwdriver
- TORX™ T6 screwdriver (0180320B16)

If a unit requires more complete testing or service than is customarily performed at the basic level, send this unit to a Motorola Authorized Service Center.

Chassis Assembly Disassembly should be performed only if necessary.



## Radio Disassembly - Detailed

### Front Cover from Chassis Disassembly

1. Turn off the radio.
2. Remove the battery:
  - a. Pull down on the two battery-release buttons.
  - b. With the buttons pulled down, the top of the battery will fall from the radio.
  - c. Remove the battery from the radio.

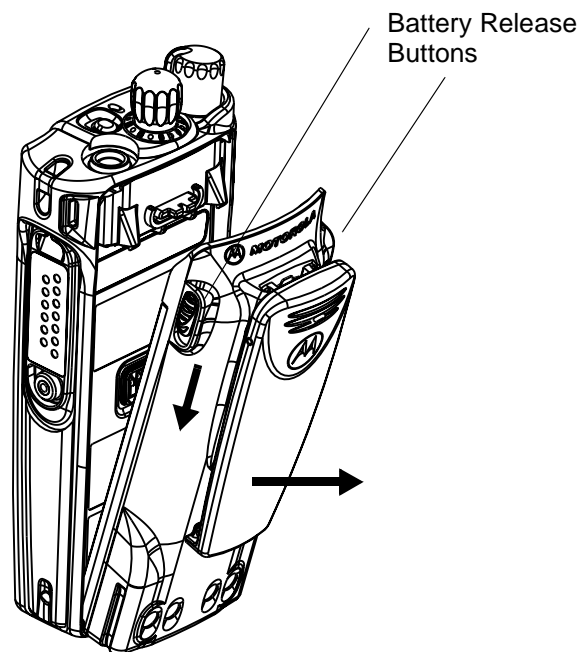

**Figure 6-1** Battery Removal

3. Remove the antenna

4. Remove the Talkgroup knob off its shaft.

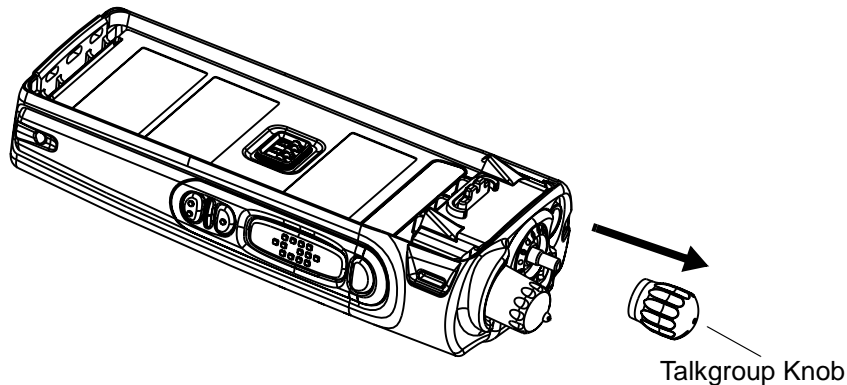

**Figure 6-2** Talkgroup Knob Removal

**NOTE** The knob slides on and off. However, it is supposed to fit very tightly on its shaft.

5. Separate the chassis from the internal electronics front cover assembly as follows:
  - a. Insert the chassis opener, or similar instrument, in between the thin retaining wall and the chassis at the bottom of the radio. Do not mar the O-ring sealing underneath the radio housing.
  - b. Slowly pry the bottom of the chassis from the cover by pushing the chassis opener down, and prying the handle of the tool over and behind the base of the radio. This prying action forces the thin inner plastic wall toward the base of the radio, releasing the two chassis base tabs.

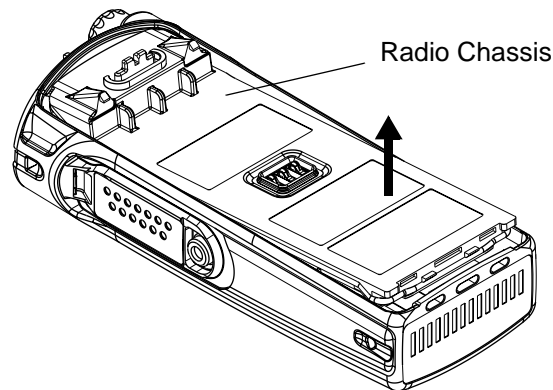

**Figure 6-3** Chassis Removal



**CAUTION:** Marring the front cover O-ring sealing area will prevent the radio from sealing properly.

**NOTE** Flexible ribbon circuits (flexes) connecting the front cover assembly and the chassis prevent you from completely separating the two units. Display radios and radios with option boards have three flexes.

6. Push the Talkgroup switch shaft back into radio housing to slide chassis away.
7. Gently remove flex from the socket connector.
8. Lay the chassis down. Rotate the front cover backward and slightly away from the chassis.
9. Lift the latches on the main circuit board to release the flexes from their connectors.

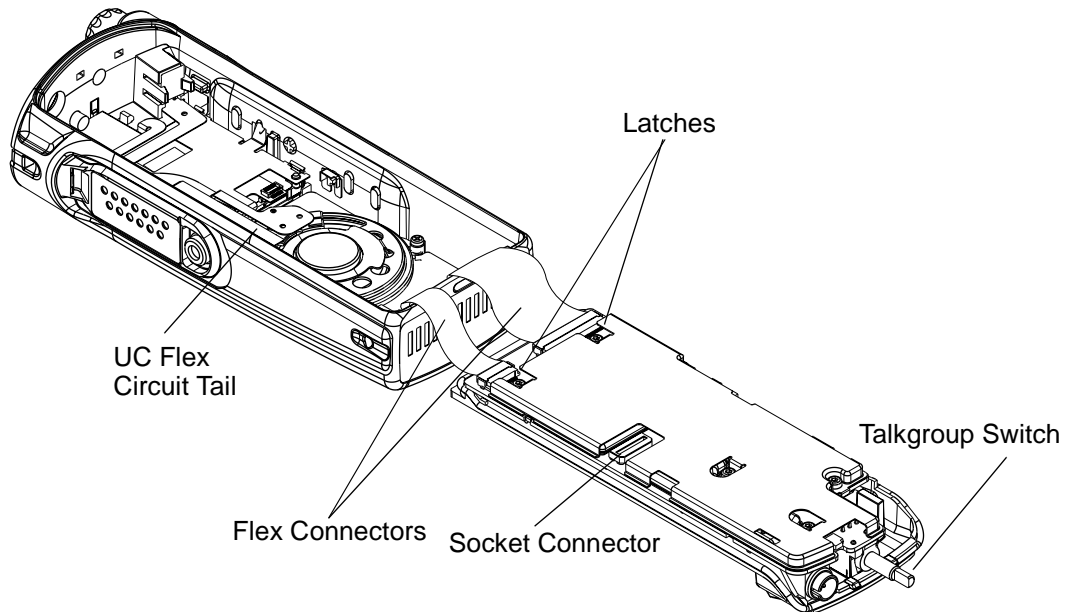

**Figure 6-4** Unlatch Flex Connectors

## Chassis Assembly Disassembly

1. Use a TORX™ screwdriver with a T6 head to remove the five screws holding the secondary shield and main board to the chassis.

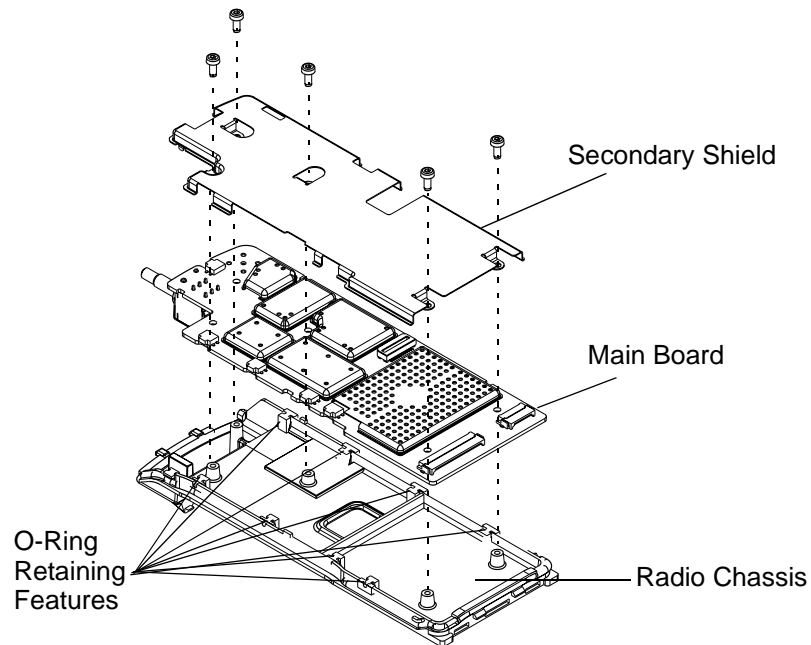

**Figure 6-5** Remove Main Board from Chassis

2. Lift the secondary shield and main board from the chassis (See Figure 6-5).



**CAUTION:** Refer to the CMOS CAUTION paragraph on page 3 before removing the main board. Be sure to use ESD protection when handling circuit boards.

3. Remove the eight small O-ring retainers from their slots in the chassis. Note the alignment of the retainers for reassembly.
4. Remove the O-ring.

---

## Radio Reassembly - Detailed

---

### Chassis Assembly Reassembly

1. Reassemble the O-ring. The tabs on the O-ring should reach around the chassis and point down.
2. Place the eight small O-ring retainers into their slots in the chassis.

**NOTE** When properly assembled, the retainers on the O-ring should align with the slots on the chassis. If this is not the case, remove and replace the O-ring until it is aligned with the chassis and completely seated in place around the perimeter.

3. Make sure the battery contact module is properly sealed on the RF board.
4. Place the main board and secondary shield straight down on top of the chassis.
5. Use the TORX™ screwdriver with a T6 head to fasten the 5 screws holding the secondary shield and main board to the chassis. Torque the screws to 0.3Nm (3lbf.in).

---

### Chassis and Front Cover Reassembly

1. Align the chassis assembly end-to-end with the front cover assembly.
2. Insert the tails of the flex circuits into their respective connectors at the bottom of the front cover.
3. Push down the latches on the connectors to hold the flex circuits to the main board.
4. Attach the UC flex circuit tail to the socket connector.
5. Slide the Talkgroup switch shaft into position in the front cover.
6. Push the chassis assembly completely into the top of the front cover until it settles in place.
7. Be sure the O-ring is properly seated.
8. Snap the bottom of the chassis into the front cover.
9. Reassemble the Talkgroup knob, antenna and battery.

10. Turn on the Volume knob and make sure radio powers up normally.

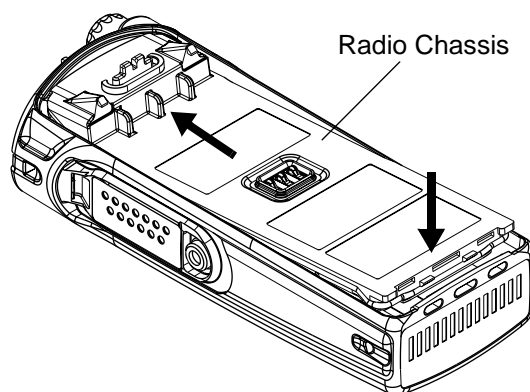

**Figure 6-6** Fastening the Chassis

## Service Aids

The following table lists the service aids recommended for working on the radio. While all of these items are available from Motorola, most are standard workshop equipment items and any equivalent item capable of the same performance may be substituted for the item listed.

Motorola Part No.	Description	Application
PMLN4510_	Programming Stand	Pocket for connecting to radio/Programming/Flashing with CPS.
FLN9636_	Programming Cable	Cable to connect PC to programming stand.
PMLN4504_	Data Cable	Cable for data transfer.
RLN4510_	Battery Eliminator Regulator, 7.5V	Regulator to power radio via battery eliminator cable.
0180305J49	Battery Eliminator Cable	Interconnects radio to power supply.
5880384G68	Antenna Adapter	SMA-BNC
6686263Z02	Chassis Opener	Tool to separate chassis from front cover housing.
0180320B16 6680321B81 6680321B56	Torx Screw Driver Kit (T6,8,10,15,25) Torx Bit Insert Bit extra long	Tool to remove torx screws in radio.
-	Phillips Screw Driver	Tool to remove speaker retainer.
-	Flat-head, Penknife-size Screw Driver	Tool to remove display retainer.

# MTP700/MTP750 Unit - Exploded View

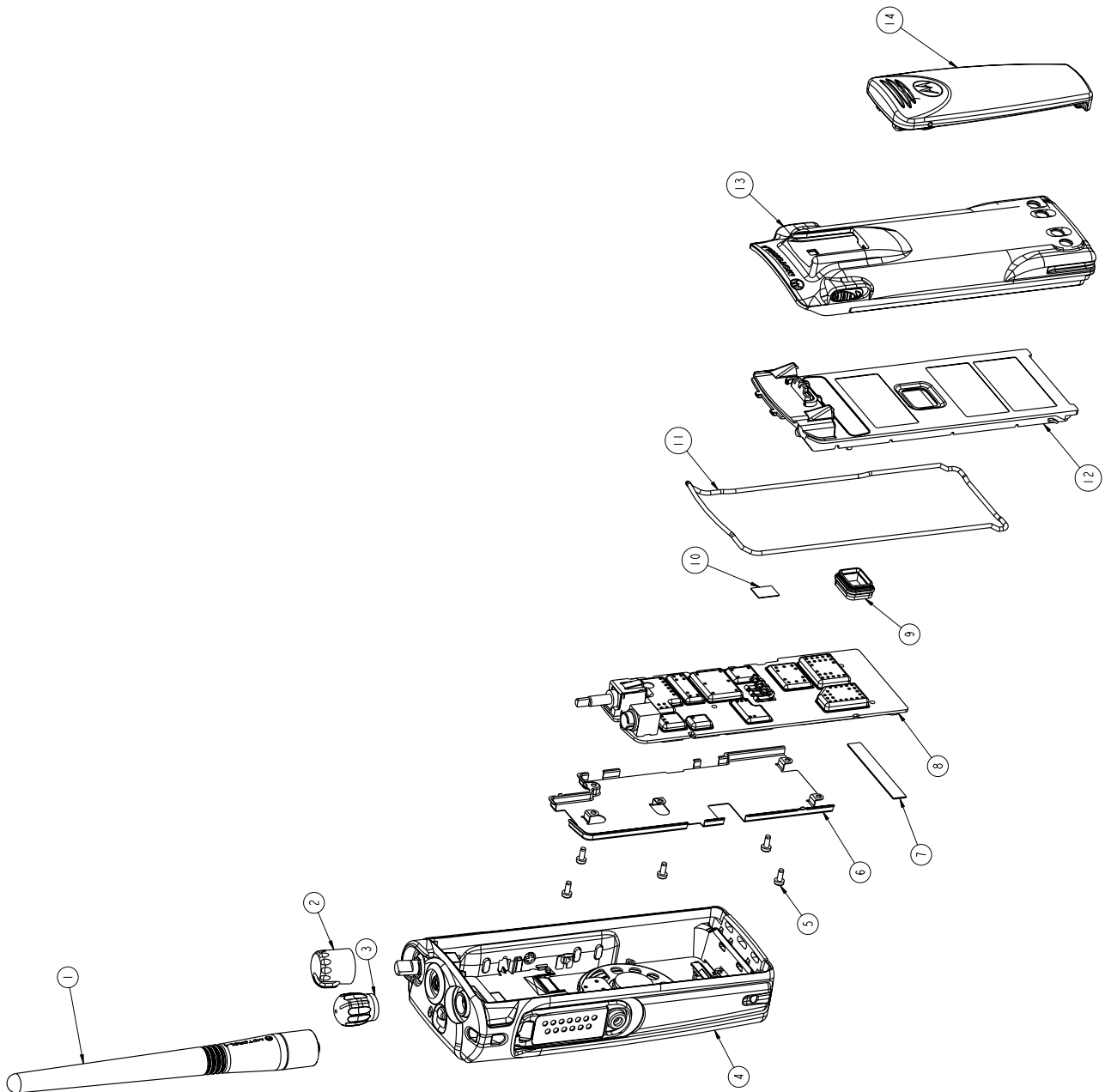

Figure 6-7 MTP700/MTP750 - Exploded view



MTP700/MTP750 components are listed in the table below. The first column marked with a # sign provides you with the call out numbers of the components as marked in MTP700/MTP750 - Exploded view.

Parts contained in this manual are the only ones that will be available for replacement.

### MTP700/MTP750 Components List

#	Description	Part #
1a	Antenna, 380 - 400 MHz	8505644V11
1b	Antenna, 410 - 430 MHz	8505644V04
1c	Antenna, 806-870 MHz, stubby	8505241U06
1d	Antenna, 806-870 MHz, whip	8505241U03
2	Knob, Volume	3686050Z01
3	Frequency Knob	3686485Z01
4a	Front Cover Kit (CR) - MTP700 English version	PMHN4038A
4b	Front Cover Kit (CR) - MTP700 Chinese version	PMHN4048A
4c	Front Cover Kit (CR) - MTP700 Korean version	PMHN4049A
4d	Front Cover Kit (Kor Mod) - MTP700 only	PMHN4040A
4e	Front Cover Kit (ES) - MTP700 English version	PMHN4039A
4f	Front Cover Kit (ES) - MTP700 Chinese version	PMHN4050A
4g	Front Cover Kit (ES) - MTP700 Korean version	PMHN4051A
4h	Front Cover Kit (CR) - MTP750 English version	PMHN4052A
4i	Front Cover Kit (CR) - MTP750 Chinese version	PMHN4053A
4j	Front Cover Kit (ES) - MTP750 English version	PMHN4055A
4k	Front Cover Kit (ES) - MTP750 Chinese version	PMHN4056A
5	Screw, Torx™ T6, Machine	0386104Z01
6	**Secondary Shield	2686046Z01
7	Escutcheon, ZIF	1386262Z01
8	*Main Board	Refer to Appendix A
9	Seal, Battery Contact Module	3280534Z02
10	Thermal Pad	7580556Z01
11	Gasket, O-Ring	3286006Z01
12	Chassis	2786007Z01
13a	Battery, Lilon, Std, 1200 mAh	PMNN4047A
13b	Battery, Lilon, Lite, 850 mAh	PMNN4050A
13c	Battery, NiMH, 1200 mAh	PMNN4048A
13d	Battery, NiMH, FM, 1150 mAh	PMNN4049A
14	Beltclip	HLN9844

Note: \* Reference Only  
Replacement or repair of all internal boards is not authorized in Latin America.

\*\* The secondary shield is not placed for PMUF1115A Super Tanapa.

**THIS PAGE INTENTIONALLY LEFT BLANK**

# APPENDIX A

## REPLACEMENT PARTS AND KITS

---

### Servicing MTP700/MTP750 Portable Units

Service for the portable units is based on the substitution method; a faulty part is replaced by a working one, providing quicker service to the customer. For example, if the transceiver board is faulty, it is replaced. If the portable requires more complete testing or servicing than that is available at field level, it is sent to your nearest Radio Service Center; where it is serviced.

The MTP700/MTP750 portables are programmed at the factory. They cannot be tuned at the field service level.

#### Level 1 and Level 2 Maintenance

This manual covers Level 1 and Level 2 Maintenance: at Level 1 Maintenance you replace the transceiver and/or accessories and send the faulty transceiver and/or accessories to a higher level of maintenance; at Level 2 Maintenance a faulty kit is replaced.

For Latin America Level 1 and Level 2 Maintenance contact your local Motorola CGISS office for information. For details, please refer to relevant Support Depots on page 1-3 to 1-5.

#### Level 3 Maintenance

The level 3 maintenance can only be done at the factory. Contact your local Motorola CGISS for information.

---

### Replacement Parts

Damaged parts should be replaced with identical replacement parts. For complete information on ordering required parts and kits, contact your local customer service representative.

## Service Kits

<b>MTP700 Model Description</b>					
MTP700, 380-430 MHz, 1W, 25kHz, with <b>Continuous Rotary knob</b> for group selection (CR)					
MTP700, 380-430 MHz, 1W, 25kHz, with <b>End Stop knob</b> for group selection (ES)					
MTP700, 806-870 MHz, 1W, 25kHz, with <b>Continuous Rotary knob</b> for group selection (CR)					
MTP700, 806-870 MHz, 1W, 25kHz, with <b>End Stop knob</b> for group selection (ES)					
MTP700, 806-870 MHz, 1W, 25kHz, with <b>End Stop knob</b> for group selection (ES), Korean Model					
				<b>*Service Boards</b>	<b>Description</b>
x				PMUE1825BS	***Transceiver FRU 380-430M 1W 25K CR
	x			PMUE1826BS	***Transceiver FRU 380-430M 1W 25K ES
		x		PMUF1077BS	***Transceiver FRU 806-870M 1W 25K CR
			x	PMUF1078BS	***Transceiver FRU 806-870M 1W 25K ES
x				PMUE1852BS	***Transceiver FRU 380-430M 1W 25K CR-TEA1
	x			PMUE1853BS	***Transceiver FRU 380-430M 1W 25K ES-TEA1
		x		PMUF1092BS	***Transceiver FRU 806-870M 1W 25K CR-TEA1
			x	PMUF1093BS	***Transceiver FRU 806-870M 1W 25K ES-TEA1
x				PMUE1856BS	***Transceiver FRU 380-430M 1W 25K CR-TEA2
	x			PMUE1857BS	***Transceiver FRU 380-430M 1W 25K ES-TEA2
		x		PMUF1096BS	***Transceiver FRU 806-870M 1W 25K CR-TEA2
			x	PMUF1097BS	***Transceiver FRU 806-870M 1W 25K ES-TEA2
			x	PMUF1115AS	Transceiver FRU 806-870M 1W 25K ES (Eriko)
x				PMUE2052AS	Transceiver FRU 380-430M 1W 25K CR (Chinese)
	x			PMUE2053AS	Transceiver FRU 380-430M 1W 25K ES (Chinese)
		x		PMUF1157AS	Transceiver FRU 806-870M 1W 25K CR (Chinese)
			x	PMUF1158AS	Transceiver FRU 806-870M 1W 25K ES (Chinese)
x				PMUE2054AS	Transceiver FRU 380-430M 1W 25K CR (Korean)
	x			PMUE2055AS	Transceiver FRU 380-430M 1W 25K ES (Korean)
		x		PMUF1159AS	Transceiver FRU 806-870M 1W 25K CR (Korean)
			x	PMUF1160AS	Transceiver FRU 806-870M 1W 25K ES (Korean)
x				PMUE2056AS	Transceiver FRU 380-430M 1W 25K CR-TEA1 (Chinese)
	x			PMUE2057AS	Transceiver FRU 380-430M 1W 25K ES-TEA1 (Chinese)
		x		PMUF1161AS	Transceiver FRU 806-870M 1W 25K CR-TEA1 (Chinese)
			x	PMUF1162AS	Transceiver FRU 806-870M 1W 25K ES-TEA1 (Chinese)
x				PMUE2058AS	Transceiver FRU 380-430M 1W 25K CR-TEA1 (Korean)
	x			PMUE2059AS	Transceiver FRU 380-430M 1W 25K ES-TEA1 (Korean)
		x		PMUF1163AS	Transceiver FRU 806-870M 1W 25K CR-TEA1 (Korean)
			x	PMUF1164AS	Transceiver FRU 806-870M 1W 25K ES-TEA1 (Korean)

## MTP700 Model Description

MTP700, 380-430 MHz, 1W, 25kHz, with <b>Continuous Rotary</b> knob for group selection (CR)					
MTP700, 380-430 MHz, 1W, 25kHz, with <b>End Stop</b> knob for group selection (ES)					
MTP700, 806-870 MHz, 1W, 25kHz, with <b>Continuous Rotary</b> knob for group selection (CR)					
MTP700, 806-870 MHz, 1W, 25kHz, with <b>End Stop</b> knob for group selection (ES)					
MTP700, 806-870 MHz, 1W, 25kHz, with <b>End Stop</b> knob for group selection (ES), Korean Model					
				<b>Front Cover</b>	<b>Description</b>
x		x			PMHN4038A Front Housing Kit CR
	x		x		PMHN4039A Front Housing Kit ES
				x	PMHN4040A Front Housing Kit ES (Eriko)
x		x			PMHN4048A Front Housing Kit CR (English/Chinese)
x		x			PMHN4049A Front Housing Kit CR (English/Korean)
	x		x		PMHN4050A Front Housing Kit ES (English/Chinese)
	x		x		PMHN4051A Front Housing Kit ES (English/Korean)

Note: \* These boards include the main board and chassis.

\*\*\* Not Field Replaceable for Latin America.

<b>MTP750 Model Description</b>		
MTP750, 380-430 MHz, 1W, 25kHz, with End Stop knob for group selection (ES)		
MTP750, 806-870 MHz, 1W, 25kHz, with End Stop knob for group selection (ES)		
	<b>*Service Boards</b>	<b>Description</b>
x	PMUE2128AS	Transceiver FRU 380-430M 1W 25K ES
x	PMUE2129AS	Transceiver FRU 380-430M 1W 25K ES (Chinese)
x	PMUE2176AS	Transceiver FRU 380-430M 1W 25K ES - TEA1
x	PMUE2178AS	Transceiver FRU 380-430M 1W 25K ES - TEA1 (Chinese)
x	PMUE2177AS	Transceiver FRU 380-430M 1W 25K ES - TEA3
x	PMUE2179AS	Transceiver FRU 380-430M 1W 25K ES - TEA3 (Chinese)
	x PMUF1179AS	Transceiver FRU 806-870M 1W 25K ES
	x PMUF1180AS	Transceiver FRU 806-870M 1W 25K ES (Chinese)
	x PMUF1182AS	Transceiver FRU 806-870M 1W 25K ES - TEA1
	x PMUF1183AS	Transceiver FRU 806-870M 1W 25K ES - TEA1 (Chinese)
	x PMUF1184AS	Transceiver FRU 806-870M 1W 25K ES - TEA3
	x PMUF1185AS	Transceiver FRU 806-870M 1W 25K ES - TEA3 (Chinese)
	<b>Front Cover</b>	<b>Description</b>
x	x PMHN4055A	Front Housing Kit ES (English)
x	x PMHN4056A	Front Housing Kit ES (Chinese)

Note: \* These boards include the main board and chassis.

\*\*\* Not Field Replaceable for Latin America.

## APPENDIX B

# CONNECTOR PIN FUNCTIONS

### General

This appendix describes the connector pin functions for the Radio. The description gives information on the type of signals, voltages and current conditions. Pins which are marked with no function, should not be connected

### Side Accessory Connector Pin Assignment

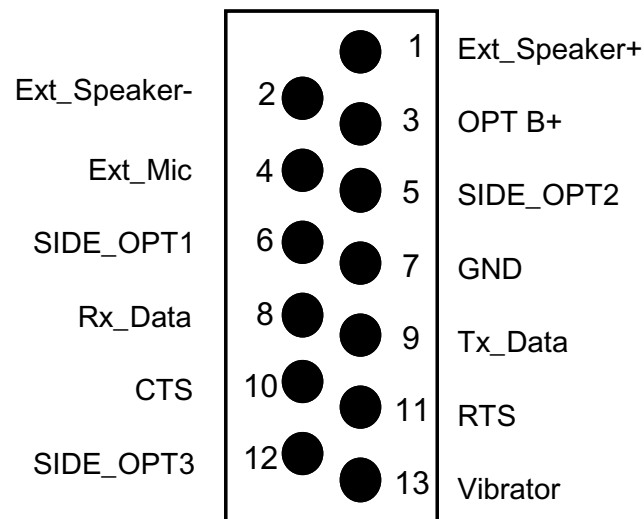

**Figure B-1** Side Accessory Connector Pin Assignment

Pin	Name	Function	Description
1	EXT_SPEAKER+	OUT	Speaker + (pin 1) and Speaker - (pin 2) are used for the external speaker. Typical output power is 0.5W for a 20 ohm load.
2	EXT_SPEAKER-	OUT	Speaker + (pin 1) and Speaker - (pin 2) are used for the external speaker. Typical output power is 0.5W for a 20 ohm load.
3	OPT_B+	OUT	With a side accessory attached, this pin provides a typical voltage of 7.5V. It is current limited at 800mA against short circuit protection.
4	EXT_MIC	IN	This is the external microphone input. Input impedance is 2 kohm with a biasing voltage of 2.775V and a typical input level of 8 mVrms.
5	SIDE_OPT2	IN	SIDE_OPT1, 2 and 3 selects the various radio operation modes with different accessories.
6	SIDE_OPT1	IN	SIDE_OPT1, 2 and 3 selects the various radio operation modes with different accessories.
7	GND	IN/OUT	Used as ground.
8	RX_DATA	IN	RS-232 input data.
9	TX_DATA	OUT	RS-232 output data.
10	CTS	OUT	Used as Clear-To-Send in RS-232 communication.
11	RTS	IN	Used as Request-To-Send in RS-232 communication.
12	SIDE_OPT3	IN	SIDE_OPT1, 2 and 3 selects the various radio operation modes with different accessories.
13	VIBRATOR	OUT	This is a logic output to enable the vibrator motor in some accessories.

**Table B-1** Side Accessory Connector Pin Functions



## Bottom Accessory Connector Pin Assignment

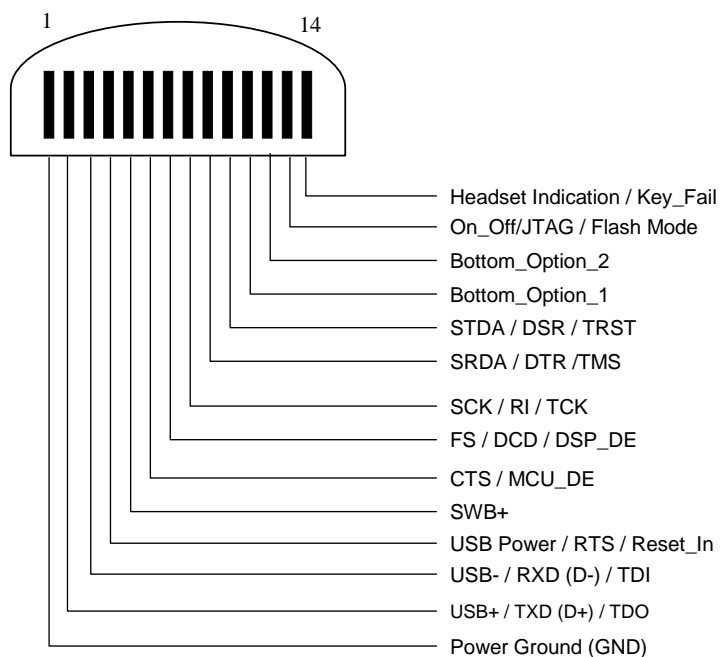

**Figure B-2** Bottom Accessory Connector Pin Assignment

Pin	Name	Function	Description
1	POWER GROUND	IN/OUT	Used as ground.
2	USB+/TXD (D+)/TDO	IN/OUT	+ve signal for the USB bus/transmit data in RS-232 mode/serial output in JTAG Mode.
3	USB-/RXD (D-)/TDI	IN/OUT	-ve signal for the USB bus/receive data in RS-232 mode/serial input in JTAG Mode.
4	USB_POWER/RTS/ RESET_IN	IN	5V power from USB Host/Used as Request-T0-Send in RS-232/Reset input in JTAG Mode.
5	SWB+	OUT	With a bottom accessory attached, this pin provides a typical voltage of 7.5V. It is current limited at 800mA against short circuit protection.
6.	CTS/MCU_DE	OUT/IN	Used as Clear-To-Send in RS-232 mode/MCU Debug Event function in JTAG Mode.
7.	FS/DCD/DSP_DE	IN/OUT	This pin is used as Frame Sync in SSI mode/Used as Data Carrier Detect in RS-232 mode/DSP Debug Event function in JTAG Mode.
8	SCK/RI/TCK	IN/OUT	This pin is used as Serial Clock in SSI mode/Used as RingIndicator in RS-232 mode/Test Clock in JTAG Mode.
9	SRDA/DTR/TMS	IN	This pin receives serial data in SSI mode/Used as Data Terminal Ready in RS-232 Mode/Test.
10	STDA/DSR/TRST	OUT	This pin transmit serial data in SSI mode/Used as Data Set Ready in RS-232 Mode/Test Reset in JTAG Mode.
11.	BOTTOM_OPTION_1	IN	BOTTOM_OPTION1 and 2 selects the varioius radio operation modes with different accessories.
12.	BOTTOM_OPTION_2	IN	BOTTOM_OPTION1 and 2 selects the various radio operation modes with different accessories.
13.	ON_OFF/JTAG/FLASH MODE	IN	Turns on the radio in SB9600 Mode/Puts the radio into JTAG Mode/Puts the radio into FLASH Mode.
14.	HEADSET INDICATION/KEY_FAIL	IN	Indicates a headset accessory is being used/Used to load the secure key for encryption.

**Table B-2** Bottom Accessory Connector Pin Functions