



Professional Series
Two-Way Radio Basic Service Manual

HT1250-LS+

200 MHz
700 MHz

Product Software License Agreement

THIS LICENSE AGREEMENT BETWEEN YOU, THE USER, AND MOTOROLA, APPLIES TO THE SOFTWARE EMBEDDED IN OR DELIVERED WITH THE ACCOMPANYING MOTOROLA PRODUCT ("SOFTWARE"), AND IS APPLICABLE UNLESS A SIGNED LICENSE AGREEMENT COVERING ITS SUBJECT MATTER HAS BEEN EXECUTED BETWEEN YOU AND MOTOROLA. BY USING THE PRODUCT, YOU ACKNOWLEDGE THAT THIS AGREEMENT HAS BEEN READ AND UNDERSTOOD AND THAT YOU AGREE TO BE BOUND BY ITS TERMS AND CONDITIONS. IF YOU DO NOT AGREE, YOU ARE NOT LICENSED TO USE THE PRODUCT, AND IF YOU ARE THE PURCHASER OF THE PRODUCT, YOU SHOULD IMMEDIATELY RETURN THE PRODUCT IN ITS ENTIRETY TO ITS PLACE OF PURCHASE FOR A REFUND.

Motorola grants to You a non-exclusive license to use the SOFTWARE in the manner described in the documentation associated with the product. Motorola retains ownership of the SOFTWARE including all patent, copyrights, and other intellectual property rights. You may transfer this license to use the SOFTWARE as long as the transferee agrees to be bound by the terms of this Agreement.

You agree not to reverse engineer or create derivative works of the SOFTWARE; not to transmit the SOFTWARE electronically; not to modify, configure, or use the SOFTWARE in any manner not authorized by MOTOROLA; and, except as an integral part of the product, not to rent, lease, or convey the SOFTWARE.

MOTOROLA SHALL NOT BE LIABLE FOR INCIDENTAL OR CONSEQUENTIAL DAMAGES ARISING FROM THE USE OF THIS SOFTWARE.

With respect to the U.S. Government, if acquired under FAR policy (52.227-19), the SOFTWARE is provided with Restricted Rights, and if acquired under DFARS policy (227.7202), then the SOFTWARE is provided only with the commercial rights of this Agreement.

This license is effective until terminated. It will terminate immediately and automatically if You fail to comply with any term of this Agreement.

You agree that this is the complete and exclusive statement of the agreement between You and Motorola and that any modification of these terms shall be made only by mutual agreement and evidenced by written amendment signed by both parties. This Agreement shall be governed and interpreted by the laws of the State of Illinois, United States of America.

Computer Software Copyrights

This manual may not be reproduced, in whole or in part, in any form whatsoever, without the express written permission of Motorola, Inc.

The Motorola products described in this manual contain one or more computer programs. These computer programs are protected by copyright law and international treaties. Unauthorized reproduction or distribution of these programs, or any part thereof, may result in severe civil and criminal penalties, and will be prosecuted to the maximum extent possible under the law. U.S. and international patents pending.

This product is covered by one or more issued U.S. Patents. Other Patent applications pending.

Product Software License Agreement

THIS LICENSE AGREEMENT BETWEEN YOU, THE USER, AND MOTOROLA, APPLIES TO THE SOFTWARE EMBEDDED IN OR DELIVERED WITH THE ACCOMPANYING MOTOROLA PRODUCT ("SOFTWARE"), AND IS APPLICABLE UNLESS A SIGNED LICENSE AGREEMENT COVERING ITS SUBJECT MATTER HAS BEEN EXECUTED BETWEEN YOU AND MOTOROLA. BY USING THE PRODUCT, YOU ACKNOWLEDGE THAT THIS AGREEMENT HAS BEEN READ AND UNDERSTOOD AND THAT YOU AGREE TO BE BOUND BY ITS TERMS AND CONDITIONS. IF YOU DO NOT AGREE, YOU ARE NOT LICENSED TO USE THE PRODUCT, AND IF YOU ARE THE PURCHASER OF THE PRODUCT, YOU SHOULD IMMEDIATELY RETURN THE PRODUCT IN ITS ENTIRETY TO ITS PLACE OF PURCHASE FOR A REFUND.

Motorola grants to You a non-exclusive license to use the SOFTWARE in the manner described in the documentation associated with the product. Motorola retains ownership of the SOFTWARE including all patent, copyrights, and other intellectual property rights. You may transfer this license to use the SOFTWARE as long as the transferee agrees to be bound by the terms of this Agreement.

You agree not to reverse engineer or create derivative works of the SOFTWARE; not to transmit the SOFTWARE electronically; not to modify, configure, or use the SOFTWARE in any manner not authorized by MOTOROLA; and, except as an integral part of the product, not to rent, lease, or convey the SOFTWARE.

MOTOROLA SHALL NOT BE LIABLE FOR INCIDENTAL OR CONSEQUENTIAL DAMAGES ARISING FROM THE USE OF THIS SOFTWARE.

With respect to the U.S. Government, if acquired under FAR policy (52.227-19), the SOFTWARE is provided with Restricted Rights, and if acquired under DFARS policy (227.7202), then the SOFTWARE is provided only with the commercial rights of this Agreement.

This license is effective until terminated. It will terminate immediately and automatically if You fail to comply with any term of this Agreement.

You agree that this is the complete and exclusive statement of the agreement between You and Motorola and that any modification of these terms shall be made only by mutual agreement and evidenced by written amendment signed by both parties. This Agreement shall be governed and interpreted by the laws of the State of Illinois, United States of America.

Computer Software Copyrights

This manual may not be reproduced, in whole or in part, in any form whatsoever, without the express written permission of Motorola, Inc.

The Motorola products described in this manual contain one or more computer programs. These computer programs are protected by copyright law and international treaties. Unauthorized reproduction or distribution of these programs, or any part thereof, may result in severe civil and criminal penalties, and will be prosecuted to the maximum extent possible under the law. U.S. and international patents pending.

This product is covered by one or more issued U.S. Patents. Other Patent applications pending.

Table of Contents

Product Safety and Standards Compliance	vii
Chapter 1 Introduction	
1.1 Scope of Manual	1-1
1.2 Warranty and Service Support	1-1
1.2.1 Warranty Period and Return Instructions	1-1
1.2.2 After Warranty Period	1-1
1.2.3 Piece Parts Availability	1-2
1.2.4 Technical Support	1-3
1.3 Radio Model Information	1-4
Chapter 2 Intrinsically Safe Radio Information	
2.1 FMRC Approved Equipment	2-1
2.2 Repair of FMRC Approved Products	2-2
2.2.1 Repair	2-2
2.2.2 Relabeling	2-2
2.2.3 Do Not Substitute Options or Accessories	2-2
Chapter 3 Maintenance	
3.1 Introduction	3-1
3.2 Preventive Maintenance	3-1
3.2.1 Inspection	3-1
3.2.2 Cleaning Procedures	3-1
3.3 Safe Handling of CMOS and LDMOS Devices	3-2
3.4 Repair Procedures and Techniques — General	3-2
3.5 Disassembling and Reassembling the Radio — General	3-3
3.6 Detailed Radio Disassembly	3-4
3.6.1 Front Cover from Chassis Disassembly	3-4
3.6.2 Chassis Assembly Disassembly	3-6
3.6.3 Keypad, Display, and Keypad/PassPort Option Board Disassembly	3-6
3.6.4 Speaker, Microphone, and Universal Connector Flex Disassembly	3-8
3.6.5 PTT Disassembly	3-9
3.6.6 Control Top Disassembly	3-9
3.7 Detailed Radio Reassembly	3-9
3.7.1 Control Top Reassembly	3-9

3.7.2	PTT Reassembly.....	3-9
3.7.3	Speaker, Microphone, and Universal Connector Flex Reassembly.....	3-10
3.7.4	Keypad, Display, and Keypad/PassPort Option Board Reassembly.....	3-10
3.7.5	Chassis Assembly Reassembly.....	3-11
3.7.6	Chassis and Front Cover Reassembly.....	3-11
3.7.7	Option Board Installation.....	3-12
3.8	HT1250•LS+ Radio Exploded Mechanical View and Parts List.....	3-13
3.9	Service Aids.....	3-15
3.10	Test Equipment.....	3-16
3.11	Configuring and Wiring the Programming/Test Cable.....	3-17

Chapter 4 Transceiver Performance Testing

4.1	General.....	4-1
4.2	RF Test Mode.....	4-1
4.3	Test Frequencies.....	4-4
4.4	Receiver and Transmitter Performance Tests.....	4-5

Chapter 5 Radio Tuning, Programming, Cloning, PassPort Tone Options and Diagnostic Functions

5.1	Introduction.....	5-1
5.2	Global Radio Tuning Setup.....	5-2
5.2.1	Initial Test Equipment Setup.....	5-2
5.3	CPS Programming Setup.....	5-3
5.4	Cloning (Conventional and LTR).....	5-3
5.4.2	Error Codes.....	5-4
5.5	Cloning (PassPort).....	5-5
5.6	PassPort Tone Options.....	5-6
5.7	Special Diagnostic Functions.....	5-6

Chapter 6 Power Up Self-Test

6.1	Error Codes - Conventional and LTR Radios.....	6-1
6.2	Error Codes - PassPort.....	6-2
6.3	Operation Display Codes.....	6-2

Chapter 7 Accessories

7.1	HT1250•LS+ Accessories	7-1
7.1.1	Antennas	7-1
7.1.2	Carrying Accessories	7-1
7.1.3	Carry Cases	7-1
7.1.4	Chargers	7-2
7.1.5	Vehicular Accessories	7-2
7.1.6	Batteries	7-2
7.1.7	Adapters	7-2
7.1.8	Miscellaneous.....	7-3
7.1.9	Service Aids	7-3
7.1.10	Audio Accessories	7-3
7.1.11	Option Boards	7-6
7.1.12	Remote Speaker Microphones.....	7-6
7.1.13	Manuals	7-6

Chapter 8 Model Chart and Test Specifications

8.1	200 MHz (LTR and PassPort)	8-1
8.2	700 MHz (LTR and PassPort)	8-2
8.3	Specifications - HT1250•LS ⁺ Radio	8-3
	Glossary of Terms	G1

List of Figures

Figure 3-1.	Battery Removal.....	3-4
Figure 3-2.	Knob Removal.....	3-4
Figure 3-3.	Chassis Removal	3-5
Figure 3-4.	Unlatch Flex Connectors.....	3-5
Figure 3-5.	Remove Main Board from Chassis	3-6
Figure 3-6.	Remove Retainer	3-7
Figure 3-7.	Removing the Keypad Retainer and Other Boards from the Radio	3-7
Figure 3-8.	Removal Speaker-Microphone Assembly	3-8
Figure 3-9.	PTT Removal	3-9
Figure 3-10.	Lock Retainer Catches to the Radio's Body.....	3-10
Figure 3-11.	Fastening the Chassis.....	3-11
Figure 3-12.	Changing Keypad/PassPort Option Board.....	3-12
Figure 3-13.	Programming/Test Cable AARKN4074.....	3-17
Figure 3-14.	Pin Configuration of the Cable Side Connector	3-17
Figure 3-15.	Programming/Test Cable Schematic	3-18
Figure 4-1.	Radio Side Button Location.....	4-2
Figure 4-2.	Two-Line Display.....	4-2
Figure 4-3.	Menu Key Identification.....	4-2
Figure 5-1.	Radio Tuning Test Equipment Setup	5-2
Figure 5-2.	CPS Programming Setup.....	5-3
Figure 5-3.	Radio Side Button Locations.....	5-4

List of Tables

Table 1-1.	Radio Model Number (Example: AAH25MDF4DP5AN)	1-4
Table 3-1.	Service Aids.....	3-15
Table 3-2.	Recommended Test Equipment	3-16
Table 4-1.	Test Environments (Side Button 1).....	4-3
Table 4-2.	Test Channel Spacing (Side Button 2)	4-3
Table 4-3.	Test Frequencies (Using the Channel Selector Switch)	4-4
Table 4-4.	Receiver Performance Checks	4-5
Table 4-5.	Transmitter Performance Checks	4-6
Table 5-1.	Software Installation Kits Radio Tuning Setup	5-1
Table 5-2.	Initial Equipment Control Settings	5-2
Table 6-1.	Power-up Display Codes - (Conventional Radios)	6-1
Table 6-2.	Power-up Display Codes (PassPort Trunking Controller Board)	6-2
Table 6-3.	Operational Display Codes	6-2

PRODUCT SAFETY AND STANDARDS COMPLIANCE



Caution

READ PRODUCT SAFETY AND STANDARDS COMPLIANCE BOOKLET BEFORE USING THIS PRODUCT!

Before using this radio, read the product safety cautions and warnings along with the operating instructions for safe usage contained in the Product Safety and Standards Compliance booklet.

ATTENTION!

This radio is restricted to occupational use only to satisfy FCC RF energy exposure requirements. See the Product Safety and Standards Compliance booklet for RF energy awareness information and operating instructions to ensure compliance with RF energy exposure limits in the FCC standard. The Product Safety and Standards Compliance booklet (Motorola Publication part # 68P81095C98) is enclosed with your radio.

Chapter 1

Introduction

1.1 Scope of Manual

This manual is intended for use by service technicians familiar with similar types of equipment. It contains service information required for the equipment described and is current as of the printing date. Changes which occur after the printing date may be incorporated by a complete Manual revision or alternatively as additions.

NOTE Before operating or testing these units, please read the Safety Information Section in the front of this manual.

1.2 Warranty and Service Support

Motorola offers support which includes: full exchange and/or repair of the product during the warranty period; and service/repair or spare parts support out of warranty. Any “return for exchange” or “return for repair” to an authorized Motorola Dealer must be accompanied by a Warranty Claim Form. Warranty Claim Forms are obtained by contacting an Authorized Motorola Dealer. (See section 1.2.4 on page 1-3.)

1.2.1 Warranty Period and Return Instructions

The terms and conditions of warranty are defined fully in the Motorola Dealer or Distributor or Reseller contract. These conditions may change from time to time, and the following subsections are for guidance purposes only.

In instances where the product is covered under a “return for replacement” or “return for repair” warranty, a check of the product should be performed prior to shipping the unit back to Motorola. This is to ensure that the product has been correctly programmed or has not been subjected to damage outside the terms of the warranty.

Prior to shipping any radio back to the appropriate Motorola warranty depot, please contact Customer Resources (Please see page 2 and page 3 in this chapter.). All returns must be accompanied by a Warranty Claim Form, available from your Customer Resources representative. Products should be shipped back in the **original packaging**, or correctly packaged to ensure that no damage occurs in transit.

1.2.2 After Warranty Period

After the Warranty period, Motorola continues to support its products in two ways:

1. Motorola's Radio Parts and Service Group offers repair service to users and dealers at competitive prices.
2. The Motorola Accessories and Aftermarket Division (AAD) supplies individual parts and modules that can be purchased by dealers who are capable of performing fault analysis and repair.

1.2.3 Piece Parts Availability

Some replacement parts, spare parts, and/or product information can be ordered directly. If a complete Motorola part number is assigned to the part, and it is not identified as Depot ONLY, it is available from the Accessories and Aftermarket Division (AAD). If no part number is assigned, the part is not normally available from Motorola. If the part number is appended with an asterisk, the part is serviceable by a Motorola Depot only. If a parts list is not included, this generally means that no user-serviceable parts are available for that kit or assembly.

Parts Order Entry

7:00 A.M. to 7:00 P.M. (Central Standard Time)

Monday through Friday (Chicago, U.S.A.)

To Order Parts:

1-800-422-4210, or 847-538-8023

1-800-826-1913, or 410-712-4907 (U.S. Federal Government)

TELEX: 280127

FAX: 1-847-538-8198

FAX: 1-410-712-4991 (U.S. Federal Government)

(U.S.A.) after hours or weekends:

1-800-925-4357

Motorola Parts

Accessories and Aftermarket Division

(United States and Canada)

Attention: Order Processing

2200 Galvin Dr.

Elgin, IL 60123

Parts Identification

1-800-422-4210 menu 3

1.2.4 Technical Support

Technical support is available to assist the dealer/distributor in resolving any malfunction which may be encountered. Initial contact should be by telephone to Customer Resources wherever possible. When contacting Motorola Technical Support, be prepared to provide the product **model number** and the unit's **serial number**.

For service you can contact one of the following Depots. Please call and confirm your return prior to sending the unit to the depot for service.

Motorola Radio Support Center

3761 South Central Avenue

Rockford, IL 61102-4294

1-800-227-6772

1-815-489-1000

Motorola Toronto Service Center

400 Matheson Blvd. W,

Mississauga, Ontario, Canada L5R 3M1

1-800-543-3222

1-416-756-5841

1-888-331-9872 (Fax)

Motorola U.S. Federal Government Depot

4395 Nicole Drive

Lanham, MD 20706

1-800-969-6680

1-301-731-6676

1.3 Radio Model Information

The model number and serial number are located on a label attached to the back of your radio. You can determine the RF output power, frequency band, protocols, and physical packages. The example below shows one portable radio model number and its specific characteristics.

Table 1-1. Radio Model Number (Example: AAH25MDF4DP5AN)

	Type of Unit	Model Series	Freq. Band	Power Level	Physical Packages	Channel Spacing	Protocol	Feature Level	Model Revision	Model Package
AA ↑ AA = Motorola Internal Use	H ↑ H = Portable	25	M (200 MHz)	C 1 or 2.5 W	F HT1250•LS+ Limited Keypad	4 12.5 kHz	DP PassPort	5 Limited Keypad	A	N
			5 (700 MHz)	D 1 or 5 W	H HT1250•LS+ Full Keypad			6 Full Keypad		

Chapter 2

Intrinsically Safe Radio Information

2.1 FMRC Approved Equipment

Anyone intending to use a radio in a location where hazardous concentrations of flammable material exist (hazardous atmosphere) is advised to become familiar with the subject of intrinsic safety and with the National Electric Code NFPA 70 (National Fire Protection Association) Article 500 (hazardous [classified] locations).

An Approval Guide, issued by Factory Mutual Research Corporation (FMRC), lists manufacturers and the products approved by FMRC for use in such locations. FMRC has also issued a voluntary approval standard for repair service ("Class Number 3605").

FMRC Approval labels are attached to the radio to identify the unit as being FM Approved for specified hazardous atmospheres. This label specifies the hazardous Class/Division/Group along with the part number of the battery that must be used. Depending on the design of the portable unit, this FM label can be found on the back of the radio housing or the bottom of the radio housing. Their Approval mark is shown below.



WARNING: Do not operate radio communications equipment in a hazardous atmosphere unless it is a type especially qualified (e.g. FMRC Approved) for such use. An explosion or fire may result.

WARNING: Do not operate the FMRC Approved Product in a hazardous atmosphere if it has been physically damaged (e.g. cracked housing). An explosion or fire may result.

WARNING: Do not replace or charge batteries in a hazardous atmosphere. Contact sparking may occur while installing or removing batteries and cause an explosion or fire.

WARNING: Do not replace or change accessories in a hazardous atmosphere. Contact sparking may occur while installing or removing accessories and cause an explosion or fire.

WARNING: Do not operate the FMRC Approved Product unit in a hazardous location with the accessory contacts exposed. Keep the connector cover in place when accessories are not used.

WARNING: Turn radio off before removing or installing a battery or accessory.

WARNING: Do not disassemble the FMRC Approved Product unit in any way that exposes the internal electrical circuits of the unit.

Radios must ship from the Motorola manufacturing facility with the hazardous atmosphere capability and FM Approval labeling. Radios will not be "upgraded" to this capability and labeled in the field.

A modification changes the unit's hardware from its original design configuration. Modifications can only be done by the original product manufacturer at one of its FMRC audited manufacturing facilities.



WARNING: Failure to use an FMRC Approved Product unit with an FMRC Approved battery or FMRC Approved accessories specifically approved for that product may result in the dangerously unsafe condition of an unapproved radio combination being used in a hazardous location.

Unauthorized or incorrect modification of an FMRC Approved Product unit will negate the Approval rating of the product.

2.2 Repair of FMRC Approved Products

REPAIRS FOR MOTOROLA FMRC APPROVED PRODUCTS ARE THE RESPONSIBILITY OF THE USER.

You should not repair or relabel any Motorola manufactured communication equipment bearing the FMRC Approval label ("FMRC Approved Product") unless you are familiar with the current FMRC Approval standard for repairs and service ("Class Number 3605").

You may want to consider using a repair facility that operates under 3605 repair service approval.



WARNING: Incorrect repair or relabeling of any FMRC Approved Product unit could adversely affect the Approval rating of the unit.

WARNING: Use of a radio that is not intrinsically safe in a hazardous atmosphere could result in serious injury or death.

FMRC's Approval Standard Class Number 3605 is subject to change at any time without notice to you, so you may want to obtain a current copy of 3605 from FMRC. Per the December, 1994 publication of 3605, some key definitions and service requirements are as follows:

2.2.1 Repair

A repair constitutes something done internally to the unit that would bring it back to its original condition Approved by FMRC. A repair should be done in an FMRC Approved facility.

Items not considered as repairs are those in which an action is performed on a unit which does not require the outer casing of the unit to be opened in a manner which exposes the internal electrical circuits of the unit. You do not have to be an FMRC Approved Repair Facility to perform these actions.

2.2.2 Relabeling

The repair facility shall have a method by which the replacement of FMRC Approval labels are controlled to ensure that any relabeling is limited to units that were originally shipped from the Manufacturer with an FM Approval label in place. FMRC Approval labels shall not be stocked by the repair facility. An FMRC Approval label shall be ordered from the original manufacturer as needed to repair a specific unit. Replacement labels may be obtained and applied by the repair facility providing satisfactory evidence that the unit being relabeled was originally an FMRC Approved unit. Verification may include, but is not limited to: a unit with a damaged Approval label, a unit with a defective housing displaying an Approval label, or a customer invoice indicating the serial number of the unit and purchase of an FMRC Approved model.

2.2.3 Do Not Substitute Options or Accessories

The Motorola communications equipment certified by Factory Mutual is tested as a system and consists of the FM Approved portable, FM Approved battery, and FM Approved accessories or options, or both. This Approved portable and battery combination must be strictly observed. There must be no substitution of items, even if the substitute has been previously Approved with a different Motorola communications equipment unit. Approved configurations are listed in the FM Approval guide published by FMRC, or in the product FM Supplement. This FM Supplement is shipped with FM Approved radio and battery combination from the manufacturer. The Approval guide, or the Approval standard Class Number 3605 document for repairs and service, can be ordered directly through Factory Mutual Research Corporation located in Norwood, Massachusetts.

Chapter 3

Maintenance

3.1 Introduction

This chapter provides details about the following:

- Preventive maintenance (inspection and cleaning)
- Safe handling of CMOS and LDMOS devices
- Disassembly and reassembly of the radio
- Installation of Optional Retrofit Kit
- Installation of Option Boards

3.2 Preventive Maintenance

The radios do not require a scheduled preventive maintenance program; however, periodic visual inspection and cleaning is recommended.

3.2.1 Inspection

Check that the external surfaces of the radio are clean, and that all external controls and switches are functional. It is not recommended to inspect the interior electronic circuitry.

3.2.2 Cleaning Procedures

The following procedures describe the recommended cleaning agents and the methods to be used when cleaning the external and internal surfaces of the radio. External surfaces include the front cover, housing assembly, and battery case. These surfaces should be cleaned whenever a periodic visual inspection reveals the presence of smudges, grease, and/or grime.

NOTE Internal surfaces should be cleaned only when the radio is disassembled for service or repair.

The only recommended agent for cleaning the external radio surfaces is a 0.5% solution of a mild dishwashing detergent in water. The only factory recommended liquid for cleaning the printed circuit boards and their components is isopropyl alcohol (70% by volume).



CAUTION: Certain chemicals and their vapors can have harmful effects on certain plastics. Avoid using aerosol sprays, tuner cleaners, and other chemicals.

Cleaning External Plastic Surface

Apply the 0.5% detergent-water solution sparingly with a stiff, non-metallic, short-bristled brush to work all loose dirt away from the radio. Use a soft, absorbent, lintless cloth or tissue to remove the solution and dry the radio. Make sure that no water remains entrapped near the connectors, cracks, or crevices

Cleaning Internal Circuit Boards and Components

Isopropyl alcohol (70%) may be applied with a stiff, non-metallic, short-bristled brush to dislodge embedded or caked materials located in hard-to-reach areas. The brush stroke should direct the dislodged material out and away from the inside of the radio. Make sure that controls or tunable components are not soaked with alcohol. Do not use high-pressure air to hasten the drying process

since this could cause the liquid to collect in unwanted places. After completing the cleaning process, use a soft, absorbent, lintless cloth to dry the area. Do not brush or apply any isopropyl alcohol to the frame, front cover, or back cover.

NOTE Always use a fresh supply of alcohol and a clean container to prevent contamination by dissolved material (from previous usage).

3.3 Safe Handling of CMOS and LDMOS Devices

Complementary metal-oxide semiconductor (CMOS) devices are used in this family of radios, and are susceptible to damage by electrostatic or high voltage charges. Damage can be latent, resulting in failures occurring weeks or months later. Therefore, special precautions must be taken to prevent device damage during disassembly, troubleshooting, and repair.

Handling precautions are mandatory for CMOS circuits and are especially important in low humidity conditions. DO NOT attempt to disassemble the radio without first referring to the following CAUTION statement.



CAUTION: This radio contains static-sensitive devices. Do not open the radio unless you are properly grounded. Take the following precautions when working on this unit:

- Store and transport all CMOS devices in conductive material so that all exposed leads are shorted together. Do not insert CMOS devices into conventional plastic “snow” trays used for storage and transportation of other semiconductor devices.
- Ground the working surface of the service bench to protect the CMOS device. We recommend using the Motorola Static Protection Assembly (part number 0180386A82), which includes a wrist strap, two ground cords, a table mat, and a floor mat.
- Wear a conductive wrist strap in series with a 100k resistor to ground. (Replacement wrist straps that connect to the bench top covering are Motorola part number RSX-4015.)
- Do not wear nylon clothing while handling CMOS devices.
- Do not insert or remove CMOS devices with power applied. Check all power supplies used for testing CMOS devices to be certain that there are no voltage transients present.
- When straightening CMOS pins, provide ground straps for the apparatus used.
- When soldering, use a grounded soldering iron.
- If at all possible, handle CMOS devices by the package and not by the leads. Prior to touching the unit, touch an electrical ground to remove any static charge that you may have accumulated. The package and substrate may be electrically common. If so, the reaction of a discharge to the case would cause the same damage as touching the leads.

3.4 Repair Procedures and Techniques — General

Parts Replacement and Substitution

When damaged parts are replaced, identical parts should be used. If the identical replacement part is not locally available, check the parts list for the proper Motorola part number and order the part from the nearest Motorola Communications parts center listed in the “Piece Parts” section of this manual (See page 1-2).

Rigid Circuit Boards

This family of radios uses bonded, multi-layer, printed circuit boards. Since the inner layers are not accessible, some special considerations are required when soldering and unsoldering components. The printed-through holes may interconnect multiple layers of the printed circuit. Therefore, exercise care to avoid pulling the plated circuit out of the hole.

When soldering near the 20-pin and 40-pin connectors:

- Avoid accidentally getting solder in the connector.

- Be careful not to form solder bridges between the connector pins.
- Examine your work closely for shorts due to solder bridges.

Flexible Circuits

The flexible circuits are made from a different material than the rigid boards, and require different soldering techniques. Excessive prolonged heat on a flexible circuit can damage the material. Therefore, avoid excessive heat and excessive bending.

For parts replacement, use the ST-1087 Temperature-Controlled Solder Station with a 600-700 degree tip, and use small diameter solder such as ST-633. The smaller size solder will melt faster and require less heat to be applied to the circuit.

To replace a component on a flexible circuit:

1. Grasp with seizers (hemostats) the edge of the flexible circuit near the part to be removed.
2. Pull gently.
3. Apply the tip of the soldering iron to the component connections while pulling with the seizers.

NOTE Do not attempt to puddle-out components. Prolonged application of heat may damage the flexible circuit.

3.5 Disassembling and Reassembling the Radio — General

Since these radios may be disassembled and reassembled with the use of only four (board to casting) screws, it is important to pay particular attention to the snaps and tabs, and how parts align with each other.

The following tools are required for disassembling the radio:

- 3/16" flat blade screwdriver
- Penknife-size screwdriver
- TORX® T6 screwdriver

If a unit requires more complete testing or service than is customarily performed at the basic level, send this unit to a Motorola Authorized Service Center. (See Chapter 1, section 1.2.4 Technical Support on page 1-3 for a list of authorized service centers.)

The following disassembly procedures should be performed only if necessary:

section 3.6.2 Chassis Assembly Disassembly on page 3-6

section 3.6.3 Keypad, Display, and Keypad/PassPort Option Board Disassembly on page 3-6

section 3.6.4 Speaker, Microphone, and Universal Connector Flex Disassembly on page 3-8

section 3.6.5 PTT Disassembly on page 3-9

section 3.6.6 Control Top Disassembly on page 3-9

section 3.7.7 Option Board Installation on page 3-12

3.6 Detailed Radio Disassembly

3.6.1 Front Cover from Chassis Disassembly

1. Turn off the radio.
2. Remove the battery:
 - a. Pull down on the two battery-release buttons.
 - b. With the buttons pulled down, the top of the battery will fall from the radio.
 - c. Remove the battery completely from the radio.

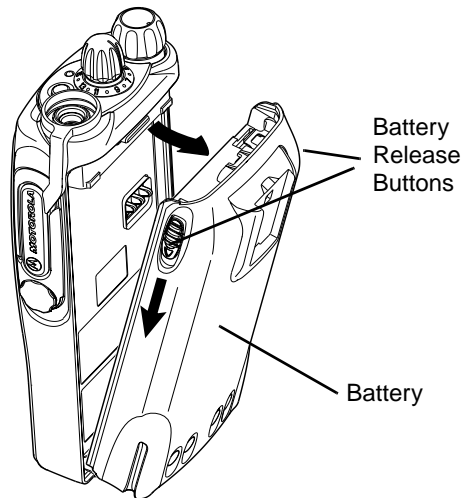

Figure 3-1. Battery Removal

3. Remove the antenna.
4. Pull the volume and channel selector knobs off their shafts.

NOTE Both knobs slide on and off. However, they are supposed to fit very tightly on their shafts.

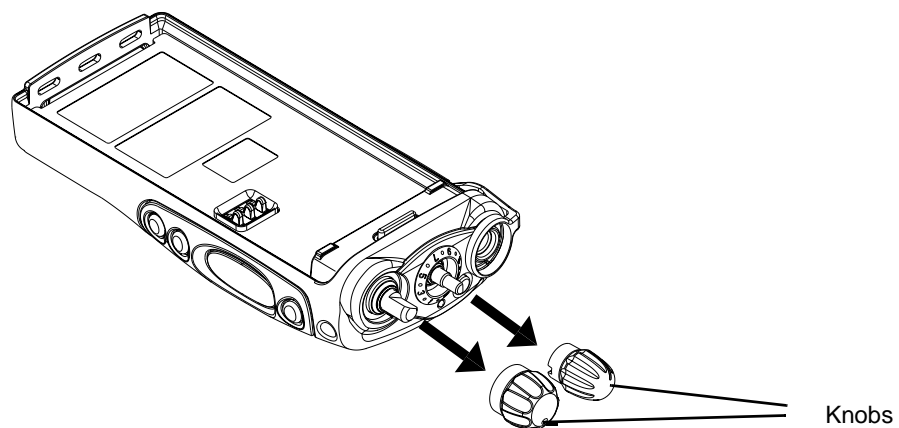

Figure 3-2. Knob Removal

5. Separate the chassis from the internal electronics front cover assembly as follows:
 - a. Insert the portable chassis removal tool, 6680702Z01, or similar instrument, in between the thin remaining wall and the chassis at the bottom of the radio. Do not mar the O-ring sealing area on the housing.
 - b. Slowly pry the bottom of the chassis from the cover by pushing the portable chassis removal tool down, and rotating the handle of the tool over and behind the base of the radio. This prying action forces the thin inner plastic wall toward the base of the radio, releasing the two chassis base tabs.

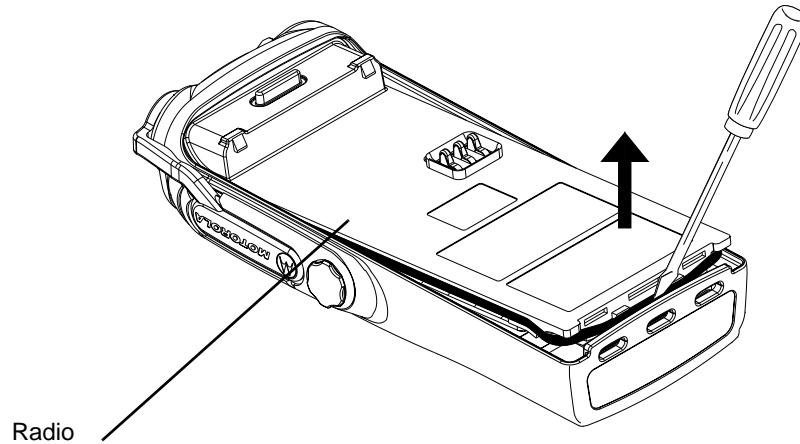

Figure 3-3. Chassis Removal



CAUTION: Marring the front cover O-ring sealing area will prevent the radio from sealing properly.

6. Lay the chassis down. Rotate the front cover backward and slightly away from the chassis.

NOTE Flexible ribbon circuits (flexes) connecting the front cover assembly and the chassis prevent you from completely separating the two units. Display radios and radios with option boards have two flexes.

7. Lift the latches on the main circuit board to release the flexes from their connectors.

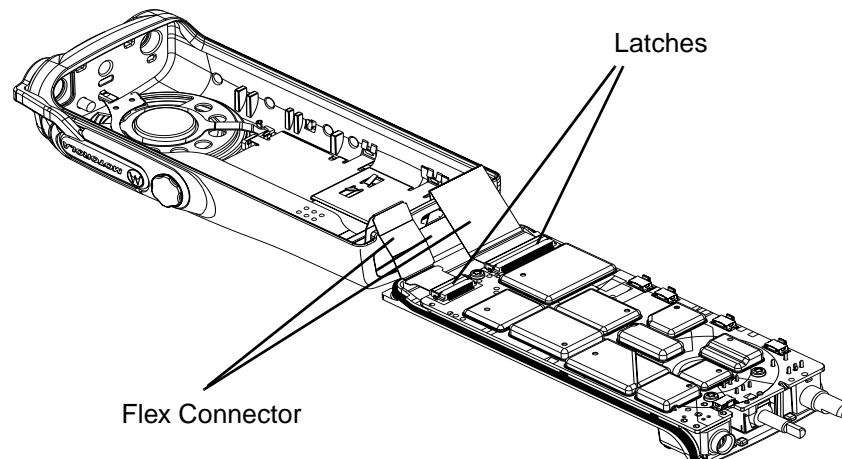

Figure 3-4. Unlatch Flex Connectors

3.6.2 Chassis Assembly Disassembly

1. If disassembly of the chassis or the main board is required, then use a TORX® screwdriver with a T6 head to remove the four screws holding the main board to the chassis.

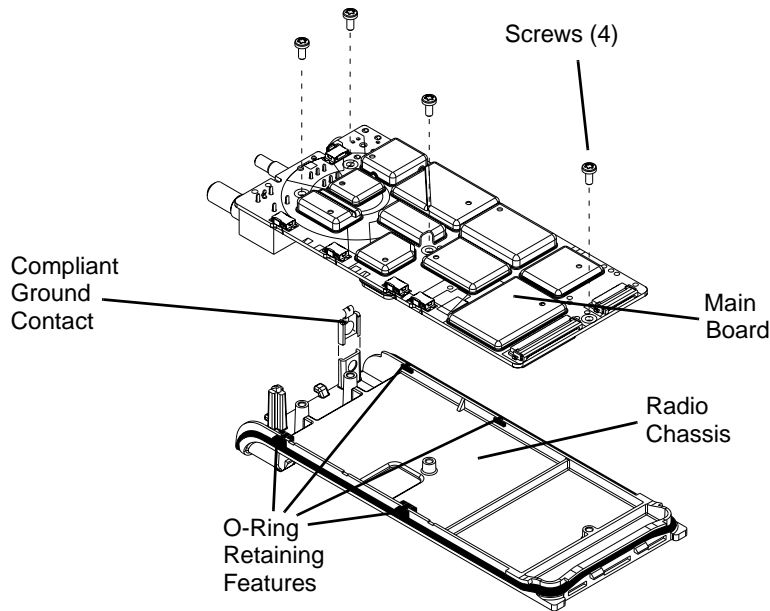

Figure 3-5. Remove Main Board from Chassis



CAUTION: Refer to the **CMOS CAUTION** on page 3-2 before removing the main board. Be sure to use ESD protection when handling circuit boards.

2. Lift the main board from the chassis (refer to Figure 3-5).
3. Remove the small O-ring retainers from their slots in the chassis. Note the alignment of the retainers for reassembly.
4. Remove the O-ring.
5. If required in disassembly, slide off the ground contact from the top corner boss of the radio chassis.

3.6.3 Keypad, Display, and Keypad/PassPort Option Board Disassembly

1. If the disassembly of the keypad or the keypad/PassPort option board, is required, lift the microphone flex circuit up, and carefully remove the microphone and its boot from the front cover pocket. See Figure 3-6, on page 3-7).
2. Lay this flex circuit to one side.
3. To remove the keypad retainer shield:
 - a. Insert the tip of a “penknife size,” flat blade screwdriver in the opening at the end of the keypad retainer arm tab.

- b. Pry the tab away from the side of the front cover until it moves past the ledges on the side wall. Repeat this procedure for the four remaining retainer arm tabs.

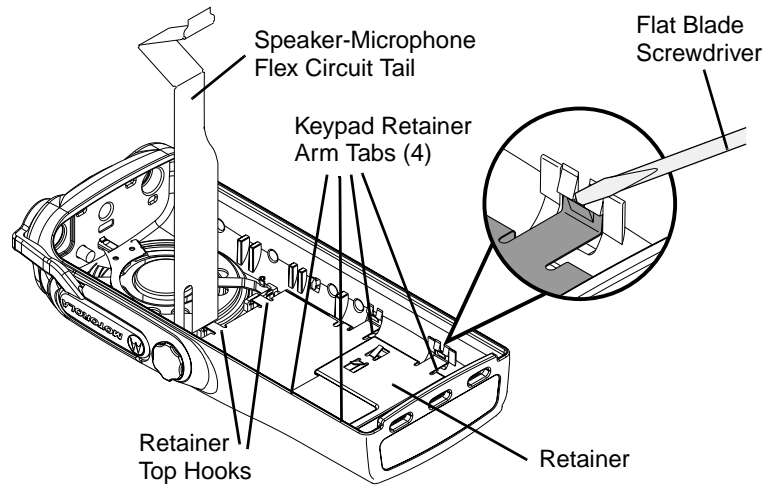

Figure 3-6. Remove Retainer

3. Note that the two “top hooks” are still held underneath the front cover—right below the speaker. Lift the keypad retainer out of the front cover, then lift and pivot the two hooks out of the front cover.
4. If disassembly involves the removal of the display module, disconnect the display flex from the keypad/PassPort option board connector by lifting the latch on the connector. (This is similar to the process for releasing the flexes.) (see page 3-5.)
5. The display module is attached to the front cover with a double-sided adhesive pad. Carefully pull up on the display module, using a small screwdriver, if necessary, and remove it from the front cover. Use a new piece of double-sided adhesive to re-mount the display to the cover.



CAUTION Take care not to damage the display. Do not cut, bend, or pinch the heat seal. Display modules contain CMOS devices. Be sure to use ESD protection.

6. The keypad/PassPort option board, can be removed without the use of tools.

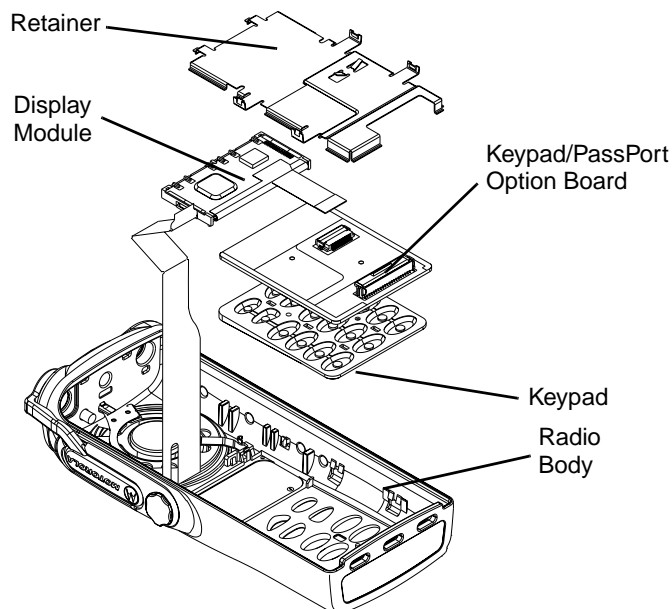

Figure 3-7. Removing the Keypad Retainer and Other Boards from the Radio

NOTE At this point, the Option Board Installation Procedure should be performed, if necessary. (See page 3-12)

3.6.4 Speaker, Microphone, and Universal Connector Flex Disassembly

1. If disassembly of the speaker-microphone assembly is necessary, remove the dustcover by turning the screw at the bottom of the dustcover counterclockwise with your fingers. Lift the dustcover out of its pocket.

NOTE The dustcover must be removed to remove the speaker-microphone assembly flex circuit. The speaker is held in place with a two-legged retainer bracket. The bracket legs are secured by the front cover slots. Be careful not to damage the speaker when removing the retainer bracket.

2. Using a screwdriver, push down on the portion of the speaker retainer bracket pointing toward the bottom of the radio. Then, remove the retainer by slightly pushing it toward the top of the radio until you slide it past the front cover slot.
3. Pull the rubber microphone boot from its seated position. Unless you are replacing the microphone, leave it in the boot.

NOTE The speaker-microphone assembly flex circuit goes through the front cover wall to the outside wall. To replace this assembly, you must peel-off the universal connector escutcheon label. The existing escutcheon cannot be reassembled; a new part must be used. (See item number 10 on the exploded view drawing on page 3-13).

4. Peel-off the universal connector flex circuit escutcheon (label).
5. Pry the flex circuit (adhesive held) backer board away from the front cover, and remove the universal connector tail of the speaker-microphone assembly through its opening in the front cover.
6. After the universal connector tail of the speaker-microphone assembly is removed, the assembly can be completely removed. If it is necessary to replace the speaker or microphone, or both, do it while the flex circuit is removed from the front cover. When reassembling the microphone in its boot, make sure the microphone port faces the round hole in the bottom of the boot.

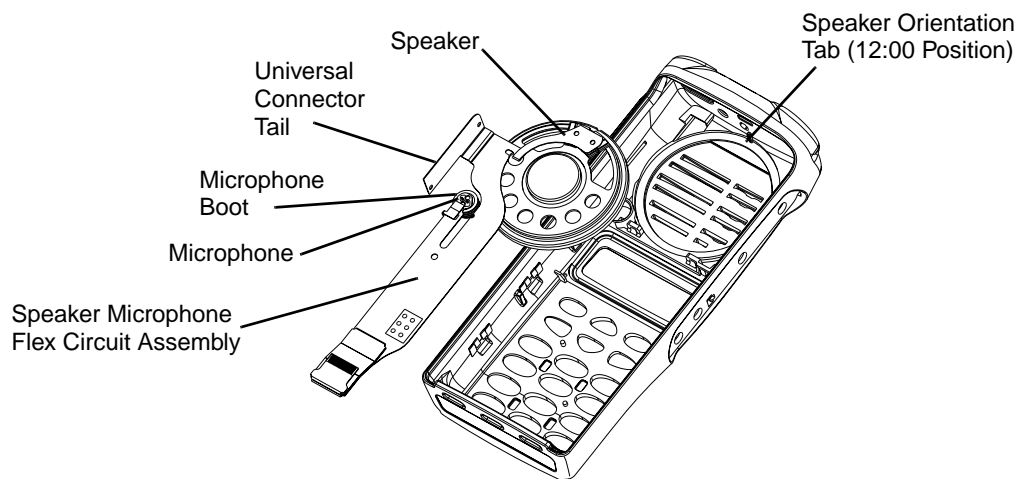

Figure 3-8. Removal Speaker-Microphone Assembly

3.6.5 PTT Disassembly

If required, the PTT bezel and the PTT seal assembly can be disassembled using a small screwdriver as follows:

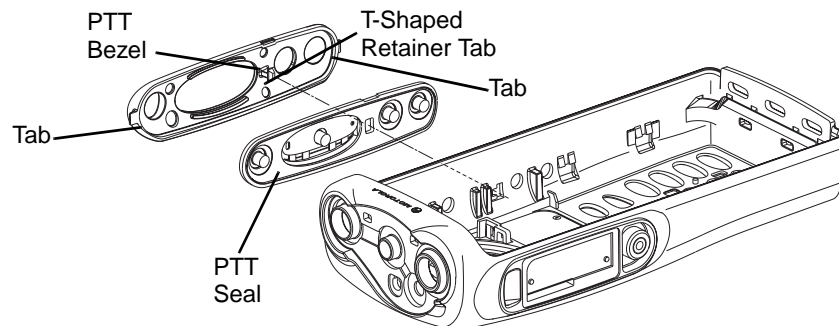

Figure 3-9. PTT Removal

- Pry back the T-tab found inside the front cover (in between the four buttons on the PTT assembly).
- Remove the PTT bezel by slightly bowing it until the top and bottom tabs are released from the slots in the front cover.
- The PTT seal can be easily lifted from the bezel without the use of tools.

3.6.6 Control Top Disassembly

- To remove the control top assembly, place a screwdriver next to the antenna boss, then pry it against the control top escutcheon. This lifts the control top escutcheon away from its double-sided adhesive. Grab the double-sided adhesive near the volume potentiometer, then lift it away.
- Remove the integrated control top seal, emergency button, and transmit light pipe.

3.7 Detailed Radio Reassembly

3.7.1 Control Top Reassembly

- Replace transmit light pipe and control top seal.
- Peel off the liners from a new control top escutcheon and place it in the recess in the front cover. Press the control top escutcheon firmly against the adhesive.

3.7.2 PTT Reassembly

- Put the PTT seal in the PTT bezel.
- Place the bezel top tab in the top slot inside the front cover PTT opening. Slightly bow the bezel so that the bottom tab can fall inside the bottom slot.
- Press the PTT assembly against the front cover opening.

NOTE Look inside the front cover to make sure the T-tab is fully engaged with the front cover. If necessary, press the T-tab toward the top of the radio until it becomes fully engaged.

3.7.3 Speaker, Microphone, and Universal Connector Flex Reassembly

1. Feed the universal connector tail of the speaker-microphone flex assembly through the opening in the side wall of the front cover.
2. Peel-off the adhesive liner on the back of the universal connector tail of the flex circuit. Attach the flex tail to the front cover using the guide pins for correct alignment.
3. Replace the universal connector escutcheon. Make sure that all the connector openings align with the gold pads on the flex circuit.
4. Align the notch in the speaker at the twelve o'clock position with the tab on the front cover as shown in Figure 3-8.
5. Place the speaker retainer bracket into the hole on the top of the front cover, and bend the retainer down to fit underneath the boss below the speaker.
6. If display, keypad, or keypad/PassPort option board are not involved, reinsert the microphone and boot into the pocket in the front cover.

3.7.4 Keypad, Display, and Keypad/PassPort Option Board Reassembly

1. If you are replacing the display, use a new double-sided adhesive display pad (item number 17 on the exploded view diagram on page 3-13).
2. Replace the keypad, and the keypad/PassPort option board. Make sure the display module flex tail is connected to the connector on the keypad/PassPort option board.
3. Insert the "top hooks" of the keypad retainer into the slots below the speaker (above the display) in the front cover. Snap all four of the retainer arm tabs in place in the front cover.

NOTE Pull the speaker-microphone flex circuit out of the way during reassembly.

4. Reinsert the microphone and boot into the pocket in the front cover.
5. Lay the speaker-microphone flex on top of keypad/PassPort option board retainer.

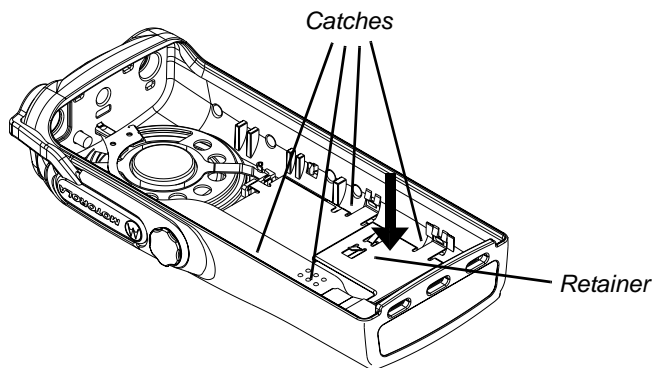

Figure 3-10. Lock Retainer Catches to the Radio's Body

3.7.5 Chassis Assembly Reassembly

1. Slide on the ground contact (if it was removed) on the top corner boss of the chassis.
2. Replace the O-ring. The tabs on the O-ring should reach into the chassis and point down.
3. Stretch the O-ring to place it into the retaining pocket at the bottom end of the chassis.

NOTE When properly assembled, the retainers on the O-ring should align with the slots on the chassis. If this is not the case, remove and replace the O-ring until it is aligned with the chassis and completely seated in place around the perimeter.

4. Ensure that the antenna nut insulator is correctly replaced by pushing it all the way to the top of the antenna nut.
5. Replace the battery contact seal (if necessary) surrounding the battery contact.
6. Place the main circuit board straight down on top of the chassis.

NOTE Be sure the battery contact seal protrudes through the chassis and is not pinched under the chassis.

7. Use the T6 TORX® screwdriver to fasten the screws holding the main board to the chassis.

3.7.6 Chassis and Front Cover Reassembly

1. Align the chassis assembly end-to-end with the front cover assembly.
2. Insert the tails of the flex circuits into their respective connectors at the bottom of the front cover.
3. Push down the latches on the connectors to hold the flex circuits to the main board.
4. Slide the volume potentiometer and frequency switch shafts into their respective holes in the front cover.
5. Push the chassis assembly completely into the top of the front cover until it settles in place.
6. Be sure the O-ring is properly seated.
7. Snap the bottom of the chassis into the front cover.
8. Reassemble the knobs, dust cover, antenna, and battery.

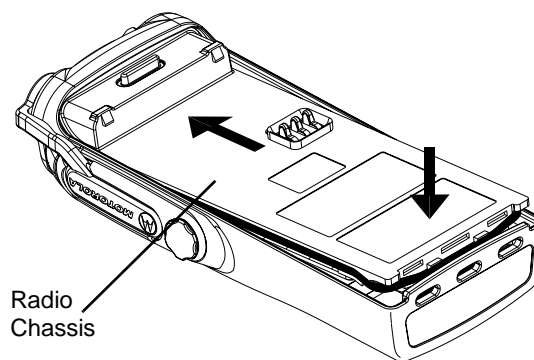

Figure 3-11. Fastening the Chassis

3.7.7 Option Board Installation

1. With the keypad retainer removed the keypad backer board can be removed without the use of tools.
2. Remove the jumper flex from the connector on the keypad/PassPort option board. Notice the orientation of the flex to the connector. Arrows on the jumper flex point to the correct way of inserting the flex into the connector.
3. Discard the keypad backer board.

NOTE The “breakaway” tab at the top of the keypad/PassPort option board contains an extra row of keys and is used to accommodate other radio models.

4. Break-off and discard the keypad/PassPort option board tab, taking care not to damage the option board. Trim any tab fragments that may remain on the option board.

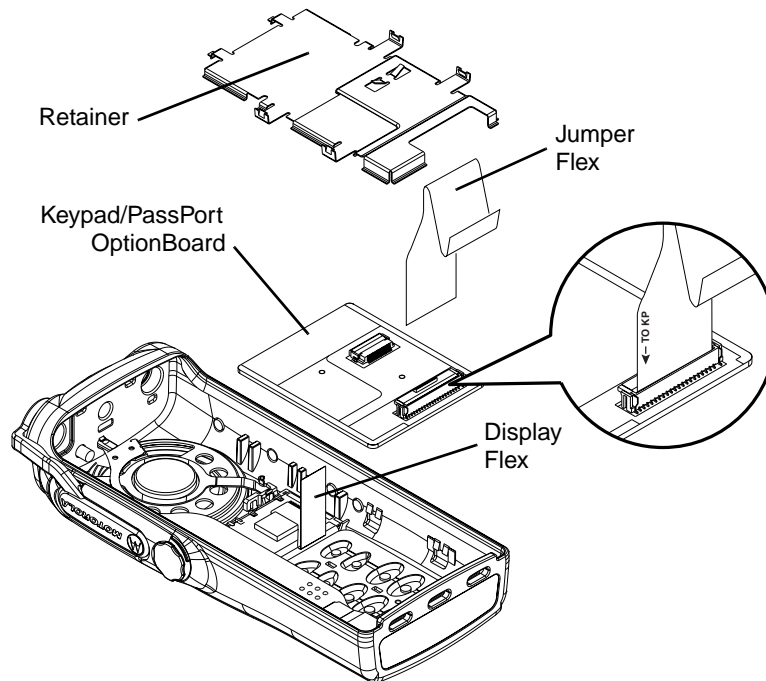
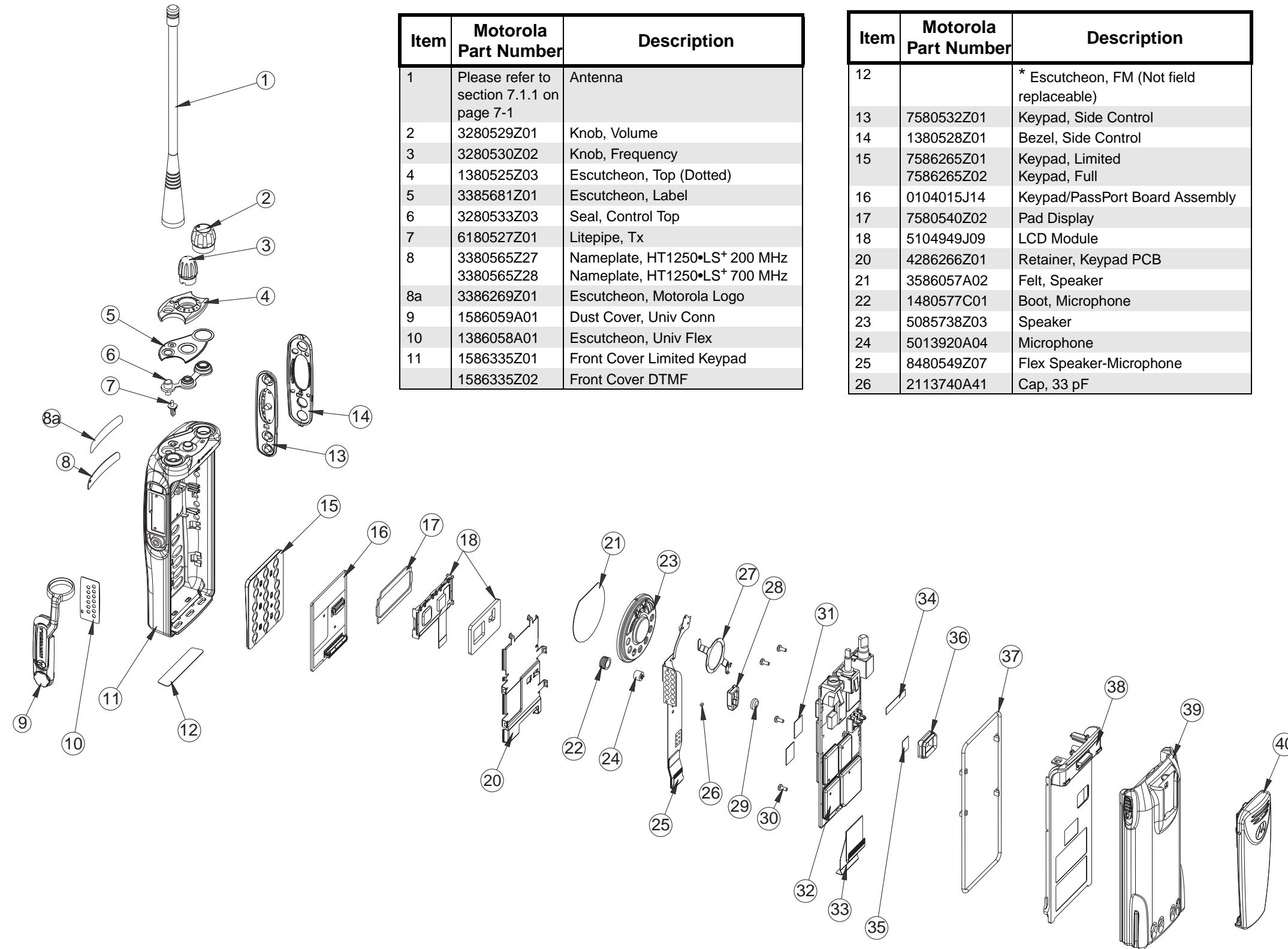

Figure 3-12. Changing Keypad/PassPort Option Board

5. Reassemble the option board to the front cover assembly.
6. Insert the display flex circuit into the connector on the option board.
7. Insert the jumper flex circuit into the connector on the option board. Notice the orientation of the flex circuit. Arrows on the jumper flex point to the correct way of inserting the flex into the connector.
8. Replace the retainer by placing the two top hooks into the slots below the speaker in the front cover; then, pivot the retainer into the front cover. Ensure that all four tab arms snap correctly into the front cover.
9. With the keypad/PassPort option board, display, and retainer correctly in place, the front cover assembly can now be reassembled per section 3.7.6 Chassis and Front Cover Reassembly on page 3-11.

3.8 HT1250•LS+ Radio Exploded Mechanical View and Parts List



Item	Motorola Part Number	Description
1	Please refer to section 7.1.1 on page 7-1	Antenna
2	3280529Z01	Knob, Volume
3	3280530Z02	Knob, Frequency
4	1380525Z03	Escutcheon, Top (Dotted)
5	3385681Z01	Escutcheon, Label
6	3280533Z03	Seal, Control Top
7	6180527Z01	Litepipe, Tx
8	3380565Z27 3380565Z28	Nameplate, HT1250•LS+ 200 MHz Nameplate, HT1250•LS+ 700 MHz
8a	3386269Z01	Escutcheon, Motorola Logo
9	1586059A01	Dust Cover, Univ Conn
10	1386058A01	Escutcheon, Univ Flex
11	1586335Z01 1586335Z02	Front Cover Limited Keypad Front Cover DTMF

Item	Motorola Part Number	Description
12		* Escutcheon, FM (Not field replaceable)
13	7580532Z01	Keypad, Side Control
14	1380528Z01	Bezel, Side Control
15	7586265Z01 7586265Z02	Keypad, Limited Keypad, Full
16	0104015J14	Keypad/PassPort Board Assembly
17	7580540Z02	Pad Display
18	5104949J09	LCD Module
20	4286266Z01	Retainer, Keypad PCB
21	3586057A02	Felt, Speaker
22	1480577C01	Boot, Microphone
23	5085738Z03	Speaker
24	5013920A04	Microphone
25	8480549Z07	Flex Speaker-Microphone
26	2113740A41	Cap, 33 pF

Item	Motorola Part Number	Description
27	4280504Z01	Retainer, Speaker
28	1480503Z01	Boot, Backup Battery
29	6080656Z01	Backup Battery
30	0304726J05	Screw
31	7580671Z01	Pad
32	See section 8.1	Ctrl/RF Board Assembly
33	8480475Z03	Flex, Keypad/Controller
34	7585746Z01	Pad, EMI, 700 MHz
35	7580556Z01	Pad, Thermal
36	3280534Z01	Seal, Contact
37	3280536Z01	Gasket, O-Ring
38	2780518Z03	Chassis
39	Please refer to section 7.1.6 on page 7-2	Battery
40	HLN9714	Belt Clip

3.9 Service Aids

Table 3-1 lists service aids recommended for working on the HT1250•LS⁺ radio.

NOTE While all of these items are available from Motorola, most are standard shop equipment items, and any equivalent item capable of the same performance may be substituted for the item listed.

Table 3-1. Service Aids

Motorola Part No.	Description	Application
RLN4460	Portable Test Set	Enables connection to audio/accessory jack. Allows switching for radio testing.
HVN9025	Customer Programming Software (CPS Plus) CD ROM. Includes PPCPS (PassPort Customer Programming Software, Global tuner, Reflashing tool, tutorial, frequency finder and frequency table).	Programs customer option and channel data. Tunes hardware parameters, front end, power, deviation, etc. Conventional, LTR, and PassPort products.
AARKN4075	Programming Cable	Includes radio interface box (RIB) capability.
AARKN4074	Programming Cable/Test Cable	Connects radio to RIB (RLN4008B).
AARKN4073	Radio to Radio Cloning Cable	Allows radio to be duplicated from a master radio by transferring programmed data from the master radio to the other.
RLN4008	Radio Interface Box	Enables communications between radio and computer's serial communications adapter.
HHLN4134	BNC Adaptor	Adapts radio antenna port to BNC cabling of equipment (VHF and UHF, B1 only).
5880313B69	SMA to BNC adapter	Adapts radio antenna port to BNC cabling of equipment (800 MHz radios).
RLN4510	Battery Eliminator 7.5 V Regulator	Works in combination with Shop Battery Block, 0180305G54.
AA0180305G54 AA8180384F68	Shop Battery Block Bench Test Housing Eliminator	Interconnects radio to power supply. Provides for troubleshooting of radio when housing is removed.
0180357A57	Wall-Mounted Power Supply (120 V AC)	Used to supply power to RIB.
3080369B72	Computer Interface Cable	Connects computer's serial communications adapter to RIB (RLN4008B).

3.10 Test Equipment

Table 3-2 lists test equipment required to service the HT1250•LS⁺ radio.

Table 3-2. Recommended Test Equipment

Motorola Part No.	Description	Characteristics	Application
R2000, R2600 R2400, or R2001 with trunking option	Service Monitor	This monitor will substitute for items listed below with an asterisk *	Frequency/deviation meter and signal generator for wide-range troubleshooting and alignment
*R1049	Digital Multimeter		Two meters recommended for AC/DC voltage and current measurements
*S1100	Audio Oscillator	67 to 200 Hz tones	Used with service monitor for injection of PL tones
*S1053, *SKN6009, *SKN6001	AC Voltmeter, Power Cable for meter, Test leads for meter	<ul style="list-style-type: none"> • 1 mV to 300 V • 10 MΩ input impedance 	Audio voltage measurements
R1053	Dual-trace Oscilloscope	20 MHz bandwidth, 5 mV/cm - 20 V/cm	Waveform measurements
*R1443A	Fixed Element 1 GHz Watt Meter	$\pm 7\%$ full scale accuracy	Transmitter power output measurements
S1339	RF Millivolt Meter	100 μ V to 3 VRF, 10 kHz to 1.2 GHz	RF level measurements
*R1013	SINAD Meter		Receiver sensitivity measurements
S1347 or S1348 (prog)	DC Power Supply	0-20 V dc, 0-5 Amps	Bench supply for 7.5 V dc

3.11 Configuring and Wiring the Programming/Test Cable

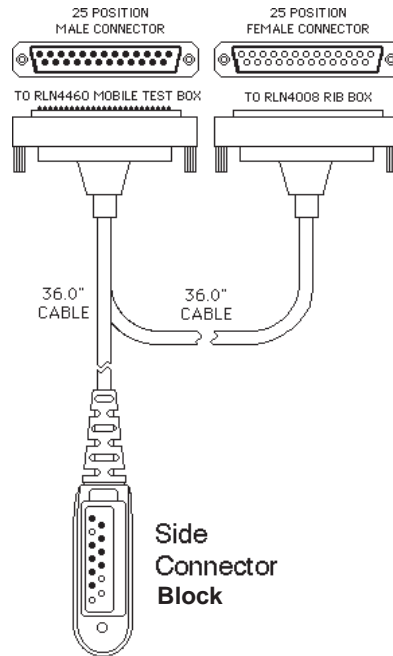

Figure 3-13. Programming/Test Cable AARKN4074

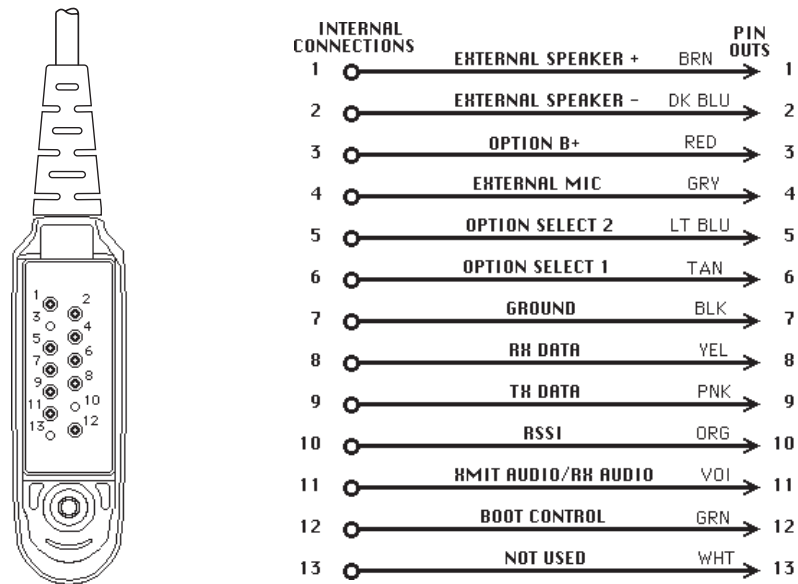

Figure 3-14. Pin Configuration of the Cable Side Connector

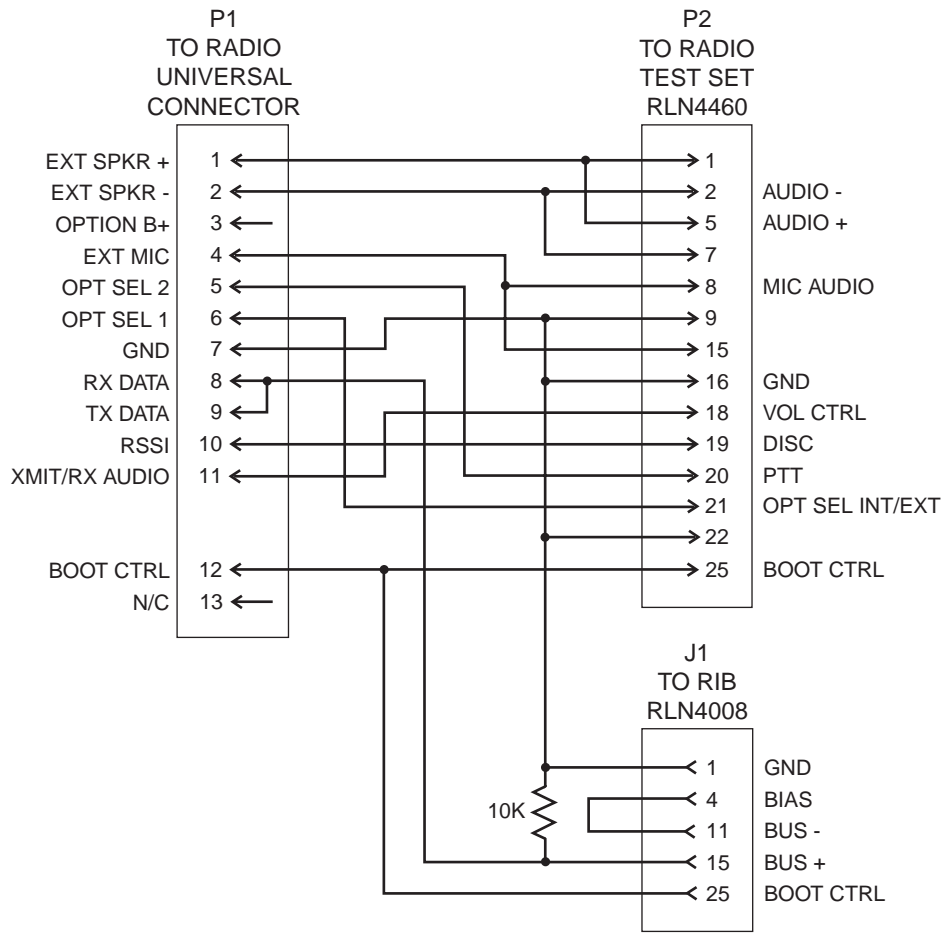

Figure 3-15. Programming/Test Cable Schematic

Chapter 4

Transceiver Performance Testing

4.1 General

These radios meet published specifications through their manufacturing process by utilizing high accuracy laboratory-quality test equipment. The recommended field service equipment approaches the accuracy of the manufacturing equipment with few exceptions. This accuracy must be maintained in compliance with the manufacturer's recommended calibration schedule.

4.2 RF Test Mode

When the radio is operating in its normal environment, the radio's microcontroller controls the RF channel selection, transmitter key-up, and receiver muting. However, when the unit is on the bench for testing, alignment, or repair, it is removed from its normal environment and cannot receive commands from its system. Therefore, the internal microcontroller does not key the transmitter or unmute the receiver. This prevents the use of a normal tuning procedure. To solve this problem, a special "test mode" is incorporated into the radio.

Note 1: The radio must be in either conventional or LTR mode.

Note 2: The test mode procedure that follows assumes that the Customer Programming Software Front Panel Access screen has both the FPA and RF TEST boxes selected. Select from the programming screen to enable or disable certain features of the radio RF test mode.

- FPA entry not selected blocks all test modes.
- FPA entry selected and RF TEST not selected blocks RF test mode.
- FPA entry selected and RF TEST selected enables all test modes.

To enter the test mode for a display radio:

1. Turn the radio on.
2. Within ten seconds after the self test is complete, press 'side button 2', shown in Figure 4-1, five times in succession.
3. After "CSQ CHXX SP25" appears on the display, the radio is on channel XX, carrier squelch mode, 25 kHz channel spacing. Each additional press of 'side button 2' (see Table 4-2) scrolls to the next channel spacing, and a corresponding set of tones are sounded. Only 12.5 kHz operation is available on these models. Do not select 25/30 kHz or 20 kHz.
4. Press 'side button 1' to scroll through the test environments listed in Table 4-1.
5. Press 'side button 2' for 3 seconds to switch the radio to the front panel test mode. 'LCD Test' appears on the display.
6. Press 'side button 1' to turn on all the dots of the first character. Another 'side button 1' press turns on all the dots of the next character, continuing until the last character is reached.
7. Press 'side button 1' at the end of the LCD test to activate the 'Icon Test'. The next 'side button 1' press turns on the first icon.
8. Press 'side button 1' at the end of the Icon Test to activate the button test. Pressing any side button (except 'side button 1'), or any keypad button during the LCD test or Icon test immediately activates this test. A good button press is verified by a chirp.

9. Press any of the 18 front panel buttons, the three programmable side buttons, the side PTT button, or the top orange button. A good button press will produce a single beep when pressed and another beep when released.
10. Rotate the On/Off/Volume control or Channel/Talkgroup/Zone/Menu knob in either direction. A series of beeps indicates proper operation.
11. Press 'side button 2' for 3 seconds in the front panel test mode to return the radio to the RF Test mode.
12. Turn radio off to exit test mode.

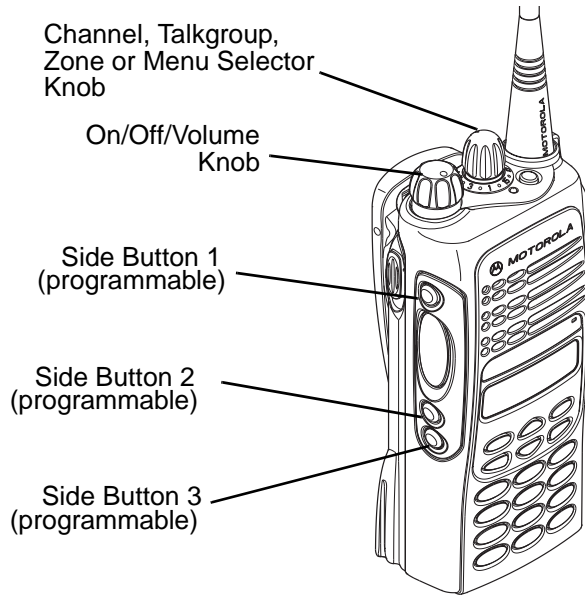

Figure 4-1. Radio Side Button Location

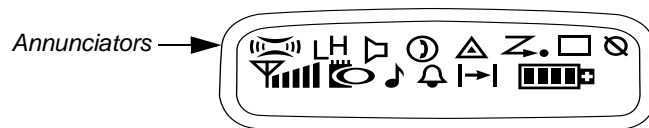

Figure 4-2. Two-Line Display

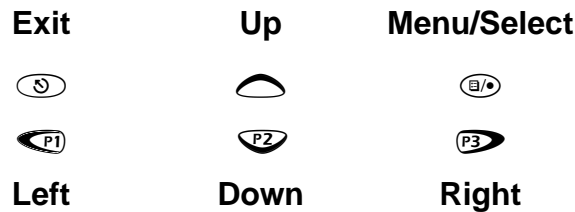

Figure 4-3. Menu Key Identification

Table 4-1. Test Environments (Side Button 1)

Number of Side Button 1 Presses	No. of Beeps	Display Shows	Description	Function
Initial (No button presses required)	0	CSQ	Carrier Squelch	RX: if carrier detected TX: mic audio
1	1	TPL	Tone Private-Line	RX: unsquelch if carrier and tone (192.8 Hz) detected TX: mic audio + tone (192.8 Hz)
2	2	DPL	Digital Private-Line	RX: unsquelch if carrier and digital code (131) detected TX: mic audio + digital code (131)
3	3	DTMF	Dual-Tone Multiple Frequency	RX: unsquelch if carrier detected TX: selected DTMF tone pair
4	5	Open	Unsquelch	RX: constant unsquelch TX: mic audio
5	9	HSS	MDC1200	RX: unsquelch if carrier detected TX: 1500 Hz tone
6	11	CMP	Compander	RX: if carrier detected TX: mic audio
7	12	LLE	Low-Level Expand	RX: if detected TX: mic audio

Table 4-2. Test Channel Spacing (Side Button 2)

Number of Low Tones	Channel Spacing
1	25/30 kHz
2	12.5 kHz
3	20 kHz

Note: Only 12.5 kHz operation is available in these models.
Do not select 25/30 or 20 kHz.

4.3 Test Frequencies

The radio channels and test frequencies are listed in Table 4.3. The channels are selected using the channel selector switch located on top of the radio, as shown in Figure 4-1. The test environment and channel spacing for any particular frequency is selected using 'side buttons 1 and 2', as listed in Tables 4-1 and 4-2. The radio shows the selected parameters on the radio display, and sounds the corresponding number of beeps and tones listed in Table 4-1.

Table 4-3. Test Frequencies (Using the Channel Selector Switch)

Channel Selector Switch Position	Test Channel	200 MHz	700 MHz
1 Low Power 8 High Power	TX #1 or #8 RX #1 or #8	217.025 MHz 217.025 MHz	746.125 MHz 746.125 MHz
2 Low Power 9 High Power	TX #2 or #9 RX #2 or #9	217.975 MHz 217.975 MHz	746.975 MHz 746.975 MHz
3 Low Power 10 High Power	TX #3 or #10 RX #3 or #10	219.125 MHz 219.125 MHz	762.125 MHz 762.125 MHz
4 Low Power 11 High Power	TX #4 or #11 RX #4 or #11	219.775 MHz 219.775 MHz	763.975 MHz 763.975 MHz
5 Low Power 12 High Power	TX #5 or #12 RX #5 or #12	220.525 MHz 220.525 MHz	776.525 MHz 763.975 MHz
6 Low Power 13 High Power	TX #6 or #13 RX #6 or #13	221.275 MHz 221.275 MHz	792.025 MHz 763.975 MHz
7 Low Power 14 High Power	TX #7 or #14 RX #7 or #14	221.975 MHz 221.975 MHz	793.975 MHz 763.975 MHz

4.4 Receiver and Transmitter Performance Tests

The receiver and transmitter performance tests are contained in Tables 4-4 and 4-5 respectively. Refer to Chapter 5, Figure 5-1, for test equipment setup. Note that all test measurements are taken at 77°F (25°C) and in conventional or trunked models.

Table 4-4. Receiver Performance Checks

Test Name	Service Monitor	Radio	Test Set	Comments
Rated Audio	Mode: GEN Output level: 1.0 mV RF 4th channel test frequency* Mod: 1k Hz tone at 3 kHz deviation Monitor: DVM: AC Volts	TEST MODE Test Channel 4 carrier squench	PTT to OFF (center), meter selector to Audio PA	Set volume control to 3.16 Vrms
Distortion	As above, except to distortion	As above	As above	Distortion 3.0% Typical
Sensitivity (SINAD)	As above, except SINAD, lower the RF level for 12 dB SINAD.	As above	PTT to OFF (center)	RF input to be 0.3μV (200 MHz models) 0.35μV (700 MHz models) or less.
Noise Squelch Threshold (only radios with conventional system need to be tested)	RF level set to 1 mV RF	As above	PTT to OFF (center), meter selection to Audio PA, speaker/load to speaker	Set volume control to 3.16 Vrms
	As above, except change frequency to a conventional system. Raise RF level from zero until radio unsquelches.	out of TEST MODE; select a conventional system	As above	Unsquelch to occur at approximately 6-9 dB SINAD

* see Table 4-3

Table 4-5. Transmitter Performance Checks

Test Name	Service Monitor	Radio	Test Set	Comments
Reference Frequency	Mode: PWR MON 4th channel test frequency* Monitor: Frequency error Input at RF In/Out	Test Channel 4 TEST MODE CSQ	PTT to continuous (during the performance check)	Frequency error ±150 Hz (200 MHz models) ±400 Hz (700 MHz models)
Power RF	As above	As above	As above	Refer to Specifications
Voice Modulation (internal)	Mode: PWR MON 4th channel test frequency* atten to -70, input to RF In/Out	Test Channel 4 TEST MODE CSQ Output at antenna	Remove modulation input	Press PTT switch on radio. Say "four" loudly into the radio mic. Measure deviation: > 1.5 kHz but ≤ 2.5 kHz (12.5 kHz Ch Sp)
Voice Modulation	Mode: PWR MON 4th channel test frequency* atten to -70, input to RF In/Out Monitor: DVM, AC Volts Set 1kHz Mod Out level for 0.025 Vrms at test set, 80mVrms at AC/DC test set jack	As above	As above, meter selector to mic	Deviation: > 1.5 kHz but ≤ 2.5 kHz (12.5 kHz Ch Sp)
High-Speed Data Modulation***	As above	Test Channel 4 TEST MODE HSS Output at antenna	PTT to continuous (during the performance check).	Deviation: > 1.5 kHz but ≤ 2.5 kHz (12.5 kHz Ch Sp)
DTMF Modulation	As above, 4th channel test frequency*	Test Channel 4 TEST MODE DTMF Output at antenna	As above	Deviation: > 1.5 kHz but ≤ 1.8 kHz (12.5 kHz Ch Sp)
PL/DPL Modulation	As above 4th channel test frequency* BW to narrow	Test Channel 4 TEST MODE TPL OR DPL Output at antenna	As above	Deviation: ≥ 250 kHz but ≤ 500 kHz (12.5 kHz Ch Sp)

* see Table 4-3

*** MDC

Chapter 5

Radio Tuning, Programming, Cloning, PassPort Tone Options and Diagnostic Functions

5.1 Introduction

This chapter provides an overview of the Customer Programming Software (CPS) and tuner program designed for use in a Windows® NT, Windows® 95, Windows® 98, Windows® 2000, and Windows® Millennium (ME), environment. These programs are available in separate kits as listed in the Table 5-1. An installation instruction manual is also included with each kit.

Note: Refer to the appropriate program on-line help files for the programming procedures.

Table 5-1. Software Installation Kits Radio Tuning Setup

Description	Kit Number
Conventional, LTR, PassPort CPS Subscription Package (3 years)	H5177
CPS Plus (Conventional, LTR, PassPort)	HVN9025
CPS Getting Started Manual	6881089C70

5.2 Global Radio Tuning Setup

A personal computer (PC), a supported Windows® environment, and a global tuner program are required to tune the radio. To perform the tuning procedures, the radio must be connected to the PC, radio interface box (RIB), and test equipment shown in Figure 5-1.

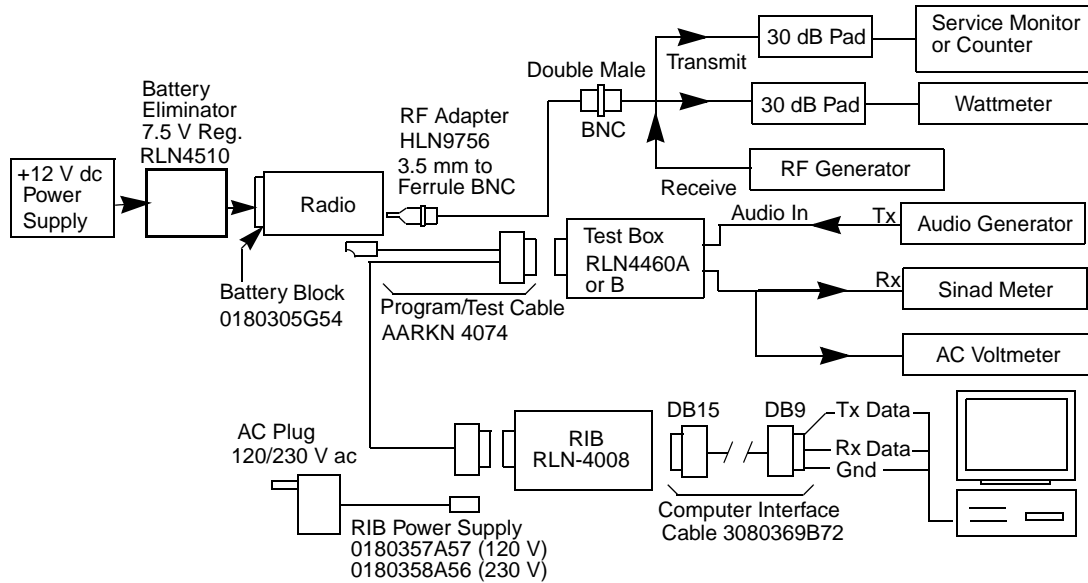

Figure 5-1. Radio Tuning Test Equipment Setup

5.2.1 Initial Test Equipment Setup

The supply voltage is connected to the radio using a Motorola battery eliminator, P/N AA0180305G54. The initial test equipment (Figure 5-1) control settings are listed in Table 5-2.

Note: Refer to appropriate program on-line help files for the tuning procedures.

Table 5-2. Initial Equipment Control Settings

Service Monitor	Test Set	Power Supply
Monitor Mode: Power Monitor	Speaker set: A	Voltage: 7.5 Vdc
RF Attenuation: -70	Speaker/load: Speaker	DC on/standby: Standby
AM, CW, FM: FM	PTT: OFF	Volt Range: 10 V
Oscilloscope Source: Mod Oscilloscope Horizontal: 10 mSec/Div Oscilloscope Vertical: 2.5 kHz/Div Oscilloscope Trigger: Auto Monitor Image: Hi Monitor BW: Nar Monitor Squelch: mid CW Monitor Volume: 1/4 CW		Current: 2.5 A

5.3 CPS Programming Setup

The CPS programming setup, shown in Figure 5-2, is used to program the radio codeplug.

Note: Refer to appropriate program on-line help files for the codeplug programming procedures.

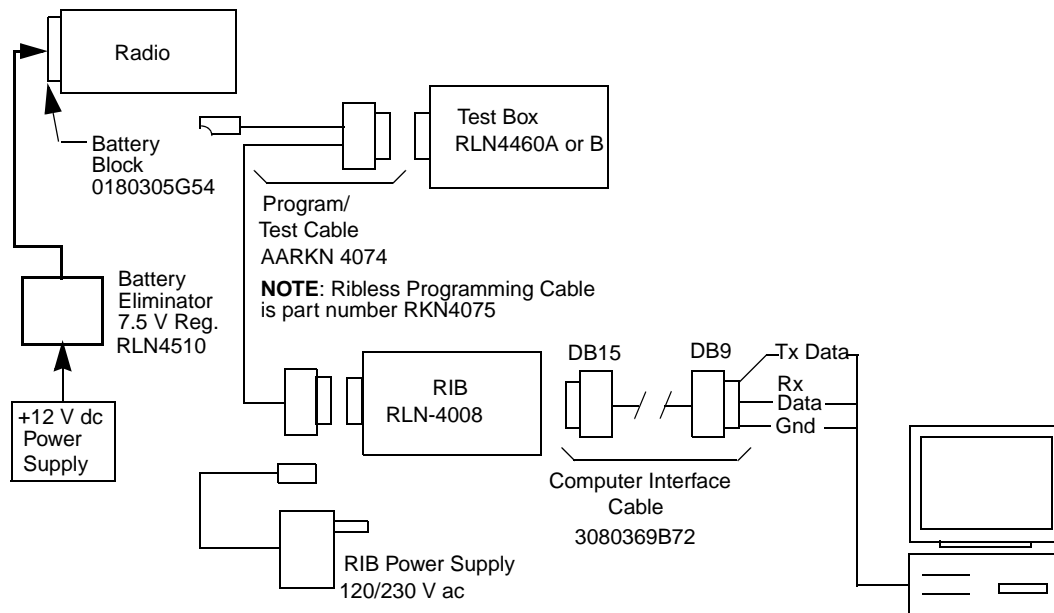

Figure 5-2. CPS Programming Setup

5.4 Cloning (Conventional and LTR)

Cloning is the same for both the Conventional and LTR radio. Cloning is the process of copying the content of one radio (source radio) into another radio (target radio). Radio content refers to system-type features such as frequency, squelch type options, trunking, etc.

Note: Cloning can be performed only on radios with identical model numbers and software options.

Radio functionality inherent in one radio cannot be cloned to another radio that does not contain the same functionality. Tuning and alignment information are not transferable and are not affected by cloning.

Signaling Identification Numbers (IDs) are duplicated in the cloning process. Unique IDs may be assigned with the CPS.

Note: Unsuccessful cloning attempts will not damage the radio.

Procedure:

1. Turn source and target radios off.
2. Connect cloning cable to side connector of both radios.
3. Turn on target radio.
4. On source radio, simultaneously press 'side buttons 1 and 2', shown in Figure 5-3, then turn radio on. Both radios produce a "clone-entry" tone and turn on their green LEDs. The radio shows "**Cloning To**" (source radio) and "**Program**" (target radio).
5. Release both side buttons. The electronic transfer process begins and will take approximately one to three minutes.

6. When cloning is completed, both radios reset themselves and turn their green LEDs off. The source radio produces a “clone-exit” tone and displays “**Clone Complete**”.
7. Turn both radios off.
8. Disconnect the cloning cable from both radios and turn them on for normal operation.

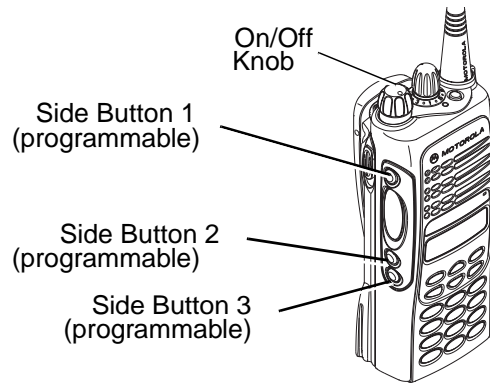

Figure 5-3. Radio Side Button Locations

5.4.2 Error Codes

- “**ERR: Mismatch**” - The model numbers or the code plug versions are not the same for both radios. Cloning cannot be performed.
- “**ERR: Timeout**” - Communication between the two radios was not established or was disrupted during the cloning process. If this occurs, check the cloning cable and all connections. Repeat the cloning procedure.



WARNING: Do NOT turn off the radio or disconnect it from the computer while attempting to PROGRAM the codeplug. Interrupting the programming process WILL DESTROY the codeplug contents and completely DISABLE the radio

Procedure:

1. Use the READ RADIO function to read the radio codeplug to be cloned. i.e. the “Source” codeplug.
2. If required, enter the Individual ID’s for the new radio. Trunking system keys (or FTR Key) are required for cloning the Trunking System Data.
3. If required, go to the SDF merge screen, to merge SDF Trunking System Data.
4. Connect “Target” radio to the computer and press READ SERIAL NUMBER button to read the “Target” radio’s serial number. This number must be different from the “Source” codeplug, or the cloning progress will fail.
5. Connect “Target” radio to the computer, and press the PROGRAM button to program the “Source” codeplug into the “Target” radio.
6. The CPS validates the code plug.
7. If it fails a warning screen is displayed informing of the incompatibility between the CPS and code plug, otherwise the information is written into the radio’s code plug.

5.5 Cloning (PassPort)

Cloning of PassPort data in the HT1250•LS⁺ may only be accomplished via the PPCPS. In order to “clone” the contents of one radio into another radio, attach the first radio to the RIB cable and read the contents of the PassPort personality by pressing the “Read Device” icon on the toolbar (or by choosing “Read Device” from the file menu and selecting the proper COM port). Select each PassPort zone and change the MIN for each zone. Attach the second radio to the RIB cable and write the personality into it by pressing the “Write Device” icon on the toolbar (or by choosing “Write Device” from the file menu and choosing the proper COM port). Alternatively, the information may be cloned to multiple radios by saving the personality data to a file. The file may, at a later time, be re-read and the MIN may be changed for each zone and then written to the radio through the procedure described above. Care must always be taken to ensure that the MIN is unique for each radio to avoid undesirable results in the system.

5.6 PassPort Tone Options

In order to provide more detailed information about the radio's state to a user or service technician various Tones and Display options are available.

One Tone option is a short low pitched tone that sounds whenever the radio loses contact for any reason with its registered PassPort site and begins to search for another site. This Tone is enabled by the "Enable LOS Search start tone" option.

Service technicians who are determining system coverage and RSSI settings may want to be able to discriminate between the LOS (Loss of System) for complete loss of data from the site or when the site RSSI drops below required levels. A second Tone following the first LOS Tone indicating that LOS was caused by complete LOS of Passport data from the site and not low.

RSSI can be activated with the "Enable LOS CRC Search start tone" option.

Enable just the "Enable LOS Search start tone" option. Allow the radio to register. Turn off the Home repeater. The radio will sound a single tone and start to search. Turn on the Home repeater. Allow the radio to register. Remove the antenna. The radio sounds a single tone and starts to search. Replace the antenna.

Enable the "Enable LOS CRC Search start tone" option also. Allow the radio to register. Turn off the Home repeater. The radio sounds two tones and starts to search. Turn on the Home repeater. Allow the radio to register. Remove the antenna. The radio sounds a single tone and starts to search.

5.7 Special Diagnostic Functions

Some special diagnosis functions can be turned on "as needed" by accessing the "Service Menu". In order to enter this menu please proceed as follows:

- 1) Press the Menu Key. (You don't need to be registered).
- 2) Quickly press the P1 then the P3 key.
- 3) Service Menu appears on the screen.
- 4) Press the Menu key to select it.

A series of functions then become available to you as you scroll up and down. They are as follows:

PassPort ESN: Enter the Service Menu and using the Up/Dn keys scroll to "**PassPort ESN**". Press the Select key. Use the Up/Dn and Select Keys to activate or deactivate this function. This function momentarily displays the radio's PassPort Electronic Serial Number.

PassPort Information Report - Enter the Service Menu and using the Up/Dn keys scroll to "Report". Press the Select key. The display sequentially shows the search method preference, the number of Near Neighbors from the last registered site neighbor list, All Neighbors, the total number of unique stored Neighbor frequencies, and the known list of Neighbor Frequencies. The report completes and the radio searches and re-registers.

Monitor - This Service Menu option defeats PassPort coded squelch and allows a technician to hear all transmissions on the system. This function can be enabled or disabled using the PassPort CPS (PPCPS).

Show RSSI - Enter the Service Menu and using the Up/Dn keys scroll to "**Show RSSI**". Press the Select key. Use the Up/Dn and Select Keys to activate or deactivate this function. This diagnostic momentarily displays the ASID and RSSI of all received site IDLE messages in the format " WXXX-YYY-ZZZ " where W is a "-" on an Idle channel and a "+" on a busy one, XXX is the ASID of the site, YYY is the RSSI of the message just received and ZZZ is the current running average RSSI. This can be helpful in determining RSSI roaming settings. Also while this feature is enabled and the radio is searching, each new search frequency is momentarily displayed in order to track the radio's progress through the known frequencies.

Search Freq-(Enter Search Frequencies): Enter the Service Menu and using the Up/Dn keys scroll to "**Search Freq**". Press the Select key. Using the numeric keys and Left (P1) key for backup/delete and the "*" key for the decimal point, enter the desired Search Frequency in MHz. Press the Select key when the entry is complete or the Escape/Exit Key to exit the function without entering a search frequency. After pressing the Select key the radio exits Menu mode and begins searching the entered frequency for a period of time equal to twice the initial search delay. This utility allows a new radio or a radio with an empty Neighbor List Almanac to search an initial frequency other than its Home Frequency or a Seed List Frequency. This can be helpful when programming and delivering a new radio to a customer in an area not served by a site on his Home Frequency.

Clear Almanac – (Clear Neighbor list Almanac): Enter the Service Menu and using the Up/ keys scroll to "**Clear Almanac**". Press the Select key. The stored Neighbor frequencies are erased. This utility allows clearing obsolete Neighbor frequencies collected.

Chapter 6

Power Up Self-Test

6.1 Error Codes - Conventional and LTR Radios

Turning on the radio starts a self-test routine that checks the RAM, ROM checksum, EEPROM hardware, and EEPROM checksum. If these checks are successful, the radio generates two high-pitched self-test pass tones, or a musical tone (selected in CPS). If the self-test is not successful, one low-pitched tone is heard the error code(s) is displayed. The displayed error codes and related corrections are listed as follows:

Table 6-1. Power-up Display Codes - (Conventional Radios)

If the error code displayed is...	then, there is a...	To correct the problem...
"RAM TST ERROR"	RAM test failure.	Retest the radio by turning it off and turning it on again. If message reoccurs, replace RAM (U405).
"ROM CS ERROR"	Wrong ROM checksum.	Reprogram FLASH memory, then retest. If message reoccurs, replace ROM (U406).
"EEPRM HW ERROR"	Codeplug structure mismatch or non existence of codeplug.	Reprogram codeplug with correct version and retest radio. If message reoccurs, replace EEPROM (U407).
"EEPRM CS ERROR"	Wrong codeplug checksum.	Reprogram codeplug.
No Display	Bad display module connection or damaged display module.	Check connection between main board and display module or replace with new display module.

6.2 Error Codes - PassPort

For the purpose of this document the phrase “PassPort Trunking Controller Board” and its acronym “PTCB” are used.

Table 6-2. Power-up Display Codes (PassPort Trunking Controller Board)

If the error code displayed is...	then, there is a...	To correct the problem...
ESN BAD	PTCB Defective.	Replace PTCB.
AppCode Fail	PTCB Firmware Defective.	Reprogram PTCB FLASH-ROM.
BackDoor		Turn radio off and restart.
ERR:Watchdog	Firmware Failure Resulted in Watchdog Timer Interrupt.	Restart radio.
Unprogrammed	Programming is not correct	Use CPS and PPCPS to properly program radio and PTCB.
ERROR: NO PTG		Use PPCPS to program that Zone with a Primary Talk Group.

6.3 Operation Display Codes

During radio operation, the radio performs dynamic tests to determine if the radio is working properly. Problems detected during these tests are presented as error codes on the radio display. The presence of an error code should prompt a user that a problem exists and that a service technician should be contacted. Use Table 6-3 to aid in understanding particular operational error code displays.

Table 6-3. Operational Display Codes

Failure Code	Description	Possible Source
FAIL 001	Synthesizer out of lock	Bad frequency data in codeplug, defective synthesizer
FAIL 002	Selected Mode (Zone/Channel) codeplug checksum error	Bad codeplug data

Chapter 7

Accessories

7.1 HT1250•LS⁺ Accessories

7.1.1 Antennas

HKAD4000	215-225 MHz, Helical
NAF5083	700 MHz 1/2 Wave, Whip

7.1.2 Carrying Accessories

All Models/All Battery Chemistries:

HLN9714	Spring 2-1/2" Belt Clip
HLN9844	Spring 1-1/2" Belt Clip
HLN9701	Nylon Carry Case with Beltloop
HLN6602	Universal Chest Pack
HLN9952	Belt Clip Carry Holder
HLN9985	Waterproof Bag
NTN5243	Carry Strap
RLN4815	Fanny Pack Carry Accessory (Universal Radio Pack)

7.1.3 Carry Cases

HT1250•LS⁺ Keypad Models	Ultra-High and High Capacity Battery Carry Cases
HLN9689	Standard Leather Case, DTMF, Beltloop
HLN9694	Standard Leather Case, DTMF, Swivel
HT1250•LS⁺ Limited Keypad Models	Ultra-High and High Capacity Battery Carry Cases
HLN9946	Standard Leather Case, Beltloop
HLN9998	Standard Leather Case, Swivel
HT1250•LS⁺ Keypad Models	Lithium Ion Battery Carry Cases
HLN9677	Standard Leather Case, DTMF, Beltloop
HLN9690	Standard Leather Case, DTMF, Swivel
HT1250•LS⁺ Limited Keypad Models	Lithium Ion Battery Carry Cases
HLN9945	Standard Leather Case, Beltloop
HLN9955	Standard Leather Case, Swivel

7.1.4 Chargers

AAHTN3000	120 V Rapid Rate Single Unit Charger Kit, U.S. 3-Prong Plug (includes Xfmr, pocket, spacer, model box, and manual)
AAHTN3003	120 V Multi-Unit Rapid Rate Charger, U.S. 3-Prong Plug (includes line cord and manual)
NLN7967	Wall Mount Kit for Multi-unit Charger
RL-76345	Battery Optimizing System (BOS) Adapter Plate
WPLN4071_R	Battery Optimizing System - 110 V AC, 50/60 Hz, 4 Station
WPLN4079-R	Battery Maintenance System Plus (BMS Plus) - 110 V AC, 50/60 Hz
WPPN4079-R	BMS Battery Adapter (For Ni-Cad and NiMH Batteries)
WPLN4107-R	Motorola Conditioning Charger Kit (includes 7.2 Volt base, removable adapter plate and transformer, 60 minute Rapid Charger, 110 V)
WPPN4065-R	Motorola Conditioning Charger. Four-Station Base only. 110 V (requires Adapter Plate)
WPPN4082-R	Adapter Plate Only (for Motorola Conditioning Charger)
RLN4853	Adapter 10 to 20 Pin

7.1.5 Vehicular Accessories

RLN4883	Travel Charger (includes voltage regulated lighter adapter, custom charger base, coil cord, and mounting bracket)
RLN4814	Vehicular Mounting Bracket (for use with Motorola Single Unit Conditioning Charger Bases)
3080384G15	Cigarette Lighter Adapter

7.1.6 Batteries

WPNN4045	1200 mAH NiMH High Capacity Battery
HNN9008	1500 mAH NiMH High Capacity Battery (Standard With Unit)
HNN9009	1900 mAH NiMH Ultra High Capacity Battery
HNN9010	1800 mAH NiMH Ultra High Capacity Battery Factory Mutual
HNN9011	1200 mAH Ni-Cd High Capacity Battery Factory Mutual
HNN9012	1300 mAH Ni-Cd High Capacity Battery
HNN9013	1200 mAH Lithium Ion High Capacity Battery

7.1.7 Adapters

AAHLN9716	GP300/P1225/P1225•LS Audio Accessory Adapter-FM Approved (not compatible with BDN6706 or BDN6646)
-----------	---

7.1.8 Miscellaneous

HLN9820	Dust Cover for Accessory Connector
HLN9793	Charger Insert Spacer - Compatible with "A" version chargers only
HLN9794	Space Charger

7.1.9 Service Aids

H5177	Customer Programming Software (CPS) - 3 Years Subscription (Conventional, LTR, and PassPort)
AARKN4073	Cloning Cable
AARKN4074	Programming/Test Cable (requires RIB box)
AARKN4075	Programming cable (includes internal Rib)
0180305G54	Shop battery eliminator cable. Requires RLN4510A (7.5 volt source)
RLN4510	7.5 Volt Universal Battery Eliminator
AA8180384F68	Bench test housing eliminator/test fixture. Requires RLN4510A 7.5V
HHLN4134	Ferrule to BNC adapter
RLN4460	Test Box
HVN9025	Customer Programming Software (CPS Plus)-CD ROM (Conventional, LTR, PassPort)
6680702Z01	Portable Chassis Removal Tool

7.1.10 Audio Accessories

AARMN4017	Ultra-Lightweight Headset with Microphone -FM Approved
AARMN4018	Lightweight Headset with Boom Microphone and In Line PTT - FM Approved
AARMN4019	Medium Weight Dual Muff Headset, Over the Head with Noise Cancelling Mic and IN Line PTT - FM Approved
AARMN4032	Medium Weight Dual Muff Headset, Over the Head with Noise Cancelling Mic - FM Approved
AARMN4020	Heavy Duty Behind the Head Headset with Noise Cancelling Boom Microphone and PTT on Earcup - FM Approved
AARMN4021	Ear Piece without Volume Control (Beige) - FM Approved
AARMN4022	2-Wire Ear Piece with Microphone and PTT (Beige) - FM Approved
AARMN4028	Ear Piece without Volume Control (Black) - FM Approved

AARMN4029	2-Wire Ear Piece with Microphone and PTT (Black) - FM Approved
RLN5316	2-Wire Comfort Ear Piece with Combined Microphone and PTT, Beige Surveillance Kits with Extended-Wear Comfort Earpieces include a Low Noise Enhancement (NTN8371) already attached for extra comfort and convenience.
RLN5315	2-Wire Comfort Ear Piece with Combined Microphone and PTT, Black Surveillance Kits with Extended-Wear Comfort Earpieces include a Low Noise Enhancement (NTN8371) already attached for extra comfort and convenience.
AARMN4031	Lightweight Headset with Swivel Boom Microphone - (FM Approved (VOX operational only on conventional channel)
RMN4051	2-Way Hard-hat Mount Headset, Black - Noise Reduction Rating = 22 dB (required RKN4097)
RMN4052	Tactical HeadBand-Style Headset, Gray - Noise Reduction Rating = 24 dB (requires RKN4097)
RMN4053	Tactical Hard-hat Mount Headset, Gray - Noise Reduction Rating = 22 dB (requires RKN4097)
RMN4054	Receive-Only Hard-hat Mount Headset with 3.5mm right angle plug - Noise Reduction Rating = 22 dB
RMN4055	Receive-Only headBand-Style Headset with 3.5mm right angle plug - Noise Reduction Rating = 24 dB
RKN4097	In-Line Adapter Cable for user with RMN4051, RMN4052, and RMN4053 Headsets
ENMN4014	3-Wire Surveillance Kit with Microphone & PTT (Black) - FM Approved
ENMN4012	Ultra Lightweight, Behind the Head, Headset with Streamlined Boom Microphone
ENMN4013	Flexible Ear Receiver (Flexible Earloop and Speaker that Rests External to the Ear
ENMN4016	Medium Duty Headset, Behind the Head, with In-line PTT with Noise Cancelling Boom Microphone
BDN6677	Ear Microphone - Black (for noise levels up to 95 dB) - requires Interface Module
BDN6678	Ear Microphone - Beige (for noise levels up to 95 dB) - requires Interface Module
BDN6641	Ear Microphone - Gray (for high noise levels from 95 dB to 105 dB) - requires Interface Module - FM Approved
RMN4044	Interface Module for PTT Operation Only - FM Approved
0180358B38	Finger Push to Talk Switch for Ear Microphone System - FM Approved

0180300E83	Body Switch Push to Talk for Ear Microphone System
AARMN4045	Ear Microphone Interface Module PTT or VOX
ENMN4017	3-Wire Surveillance Kit with Microphone and PTT (Beige)
NTN1722	Integrated Ear Microphone/Receiver System with PTT on Radio Adapter - FM Approved
NKN6508	Replacement Cable for NTN1722
NTN1723	Integrated Ear Microphone/Receiver System with Palm PTT - FM Approved
NKN6510	Replacement Palm PTT Cable for NTN1723
NTN1724	Integrated Ear Microphone/Receiver System with Ring PTT - FM Approved
NKN6512	Replacement Ring PTT Cable for NTN1723
NNTN4187	Integrated Microphone/Receiver with Remote Push-to-Talk Body Switch - FM Approved
AAHLN9717	Replacement Audio Adapter with 3.5mm Jack for CommPort Integrated Microphone Receiver System
425838B01	Replacement Clothing Clip for CommPort Integrated Microphone Receiver System
NNTN4188	Replacement Remote Push-to-Talk Body Switch
NTN8821	CommPort Maintenance Kit - includes Replacement Ear Tubes (qty. 10), Windscreens (qty. 2) and Microphone Seal Strips (qty. 10)
RLN5037	Replacement Ear Tubes (qty 10)
NTN8986	Adhesive Pads (qty. 90) for Secure Attachment to the Ear
NTN8988	Ear Straps (qty. 10) for Secure Attachment to the Ear
NKN6525	Replacement Snap-on-Side PTT Cable for NTN1737
AARLN4885	Receive Only Foam Earbud with 3.5mm plug - (for use with AAHMN9053, AAHMN8054, and AAHMN9057) - FM Approved
RLN4941	Receive-Only Earpiece with translucent tube, rubber eartip, and 3.5mm plug (for use with AAHMN9053, AAHMN9054, and AAHMN9057)
RLN4922	Completely Discrete Earpiece Kit - must be used with any standard 2 or 3 wire surveillance earpiece kit
NTN8370	Extreme Noise Earpiece Adapter Kit, Noise Reduction Rating - 28 dB (for use with AARMN4022 and AARMN4029)
NTN8371	Low Noise Earpiece Adapter Kit (for use with AARMN4022 and AARMN4029)
RLN4760	Small Custom Earpiece, Right Ear (for use with NTN8371)

RLN4761	Medium Custom Earpiece, Right Ear (for use with NTN8371)
RLN4762	Large Custom Earpiece, Right Ear (for use with NTN8371)
RLN4763	Small Custom Earpiece, Left Ear (for use with NTN8371)
RLN4764	Medium Custom Earpiece, Left Ear (for use with NTN8371)
RLN4765	Large Custom Earpiece, Left Ear (for use with NTN8371)

7.1.11 Option Boards

01-04015J14	LS ⁺ PassPort Option Board
-------------	---------------------------------------

7.1.12 Remote Speaker Microphones

AAHMN9052	Remote Speaker Standard Microphone - FM Approved
AAHMN9053	Remote Speaker Noise Cancelling Microphone - FM Approved
AAHKN9055	Replacement Cable for Standard and Noise Cancelling

7.1.13 Manuals

6864110R12	HT1250•LS ⁺ 200/700 MHz Detailed Service Manual
6864110R11	HT1250•LS ⁺ 200/700 MHz User Guide
6881092C58	Installation Manual

Chapter 8

Model Chart and Test Specifications

8.1 200 MHz (LTR and PassPort)

Description		<h1>HT1250•LS⁺ Portable Radio 200 MHz</h1>	
Model			
Item			
AAH25MDF4DP5AN	HT1250•LS ⁺ 200 MHz (Limited Keypad)		
AAH25MDH4DP6AN	HT1250•LS ⁺ 200 MHz (Full Keypad)		
X		PMUD1760AAN	Board, HT1250•LS ⁺ 200 MHz (Limited Keypad)
	X	PMUD1761AAN	Board, HT1250•LS ⁺ 200 MHz (Full Keypad)
X		PMHD4011	Back Cover Kit (Limited Keypad)
	X	PMHD4012	Back Cover Kit (Full Keypad)
X		PMLN4405	Front Cover Kit (Limited Keypad)
	X	PMLN4404	Front Cover Kit (Full Keypad)
X	X	HKAD4000	Helical 216-255 MHz Antenna
X	X	HNN9008	NiMH High Capacity Battery
X	X	HLN9714	2.5" Spring Belt Clip
X	X	AAHTN3000	120 V Rapid Single Unit Charger
X	X	6864110R11	User Guide

X = Indicates one of each is required.

8.2 700 MHz (LTR and PassPort)

Description			
Model			
HT1250•LS ⁺ 700 MHz (Limited Keypad)		AAH255CF4DP5AN	
HT1250•LS ⁺ 700 MHz (Full Keypad)		AAH255CH4DP6AN	
<h1>HT1250•LS⁺ Portable Radio 700 MHz</h1>			
		Item	Description
X		PMUF1104AAN	HT1250•LS ⁺ 700 MHz (Limited Keypad)
	X	PMUF1105AAN	HT1250•LS ⁺ 700 MHz (Full Keypad)
X		PMHF4004	Back Cover Kit (Limited Keypad)
	X	PMHF4005	Back Cover Kit (Full Keypad)
X		PMLN4405	Front Cover Kit (Limited Keypad)
	X	PMLN4404	Front Cover Kit (Full Keypad)
X	X	NAF5083	1/2 Wave Whip Antenna (746-795 MHz)
X	X	HNN9008	NiMH High Capacity Battery
X	X	HLN9714	2.5" Spring Belt Clip
X	X	AAHTN3000	120 V Rapid Single Unit Charger
X	X	6864110R11	User Guide

X = Indicates one of each is required.

8.3 Specifications - HT1250•LS⁺ Radio

General				
Specification	200 MHz		700 MHz	
Model Numbers: Limited Keypad: Full Keypad:	AAH25MDF4DP5AN AAH25MDH4DP6AN		AAH255CF4DP5AN AAH255CH4DP6AN	
Frequency Range:	217-218 MHz 219-222 MHz		Transmit: 746-747 MHz (Talkaround) 762-764 MHz (Talkaround) 776-777 MHz 792-794 MHz Receive: 746-747 MHz 762-764 MHz	
Frequency Stability: (-30°C to +60°C, 25°C Ref.)	±2.5 ppm		±1.5 ppm	
Channel Capacity:	Trunking zone 15 Trunking Talkgroup 16 (per zone) Conventional Channels 16			
Channel Spacing:	12.5 kHz			
Power Supply:	7.5 volts rechargeable battery			
Dimensions: H x W x D With NiMH High Capacity Battery: With NiMH Ultra-High Capacity Battery: With NiCd Battery: With Lilon Battery:	5.40 in. x 2.26 in. x 1.50 in. (137mm x 57.5 mm x 37.5mm) 5.40 in. x 2.26 in. x 1.60 in. (137mm x 57.5 mm x 40mm) 5.40 in. x 2.26 in. x 1.60 in. (137mm x 57.5 mm x 40mm) 5.40 in. x 2.26 in. x 1.30 in. (137mm x 57.5 mm x 33mm)			
Weight: With NiMH High Capacity Battery: With NiMH Ultra-High Capacity Battery: With NiCd Battery: With Lilon Battery:	15.0 ounces (420 grams) 17.5 ounces (500 grams) 15.8 ounces (450 grams) 12.5 ounces (350 grams)		15.0 ounces (420 grams) 17.5 ounces (500 grams) 15.8 ounces (450 grams) 12.5 ounces (350 grams)	
Average Battery Life @ 5-5-90 Duty Cycle*: With NiMH High Capacity Battery: With NiMH Ultra-High Capacity Battery: With NiCd Battery: With Lilon Battery:	Low Power 11 hours 14 hours 12 hours 11 hours	High Power 8 hours 11 hours 9 hours 8 hours	Low Power 11 hours 14 hours 12 hours 11 hours	High Power 8 hours 11 hours 9 hours 8 hours
Sealing:	Passes rain testing per IP54 and MIL-STD 810E			
Shock:	Meets MIL-STD-810-C,D & E and TIA/EIA 603			
Vibration:	Meets MIL-STD-810-C,D & E and TIA/EIA 603			
Dust:	Meets MIL-STD-810-C,D & E and IP54			
Humidity:	Meets MIL-STD-810-C,D & E and TIA/EIA 603			
FCC Designation:	ABZ99FT3080		ABZ99FT5000	
* 5% receive, 5% transmit, 90% standby				

Transmitter		
Specification	200 MHz	700 MHz
Power Output NiMH @ 7.5V:	1 or 5 W	1 or 2.5 W
Conducted and Radiated Emission:	-16 dBm	-16 dBm (except -40 dBm from 1559-1610 MHz)
Adjacent Channel Coupled Power:	N/A	Complies with 47 CFR 27.53 (d) (1)
Audio Response: (from 6 dB/oct. Pre-Emphasis, 300 to 3000 Hz):	+1 to -3 dB	
Audio Distortion: @ 1000 Hz, 60% Rated Max. Dev.	3% Typical	
Modulation Limiting:	±2.5 kHz	
FM Hum and Noise:	-40 dB typical	
FM Modulation Designator:	11K0F3E	

Receiver		
Specification	200 MHz	700 MHz
Sensitivity (12 dB SINAD):	0.3 μ V (0.25 μ V Typical)	0.35 μ V (0.3 μ V Typical)
Intermodulation:	70 dB	
Adjacent Channel Selectivity:	60 dB (EIA/TIA 603) 40 dB (EIA/TIA 603A)	
Spurious Rejection:	70 dB	
Rated Audio:	0.5 W	
Audio Distortion @ Rated Audio:	3% Typical	
Hum and Noise:	-40 dB	
Audio Response (from 6 dB/oct. De-Emphasis, 300 to 3000 Hz):	+1 to -3 dB	
Conducted Spurious Emission per FCC Part 15:	-57 dBm <1 GHz -47 dBm >1 GHz	
Specifications subject to change without notice. All electrical specifications and methods refer to EIA/TIA 603 standards. PRO Series radios meet or exceed requirements of MIL STD 810 C, D, E.		

Glossary of Terms

Term	Definition
ALC	Automatic Level Control: a circuit in the transmit RF path that controls RF power amplifier output, provides leveling over frequency and voltage, and protects against high VSWR (voltage standing wave ration).
ASFIC	Audio Signaling Filter Integrated Circuit with voice compander.
CD	Compact Disk.
CMP	Compression.
CPS	Customer Programming Software.
CSQ	Carrier Squelch.
DTMF	Dual-Tone Multifrequency.
DPL	Digital Private-Line.
EEPROM	Electronically Erasable/Programmable Read-Only Memory: used by the radio to store its personality.
Firmware	Software, or a software/hardware combination of computer programs and data, with a fixed logic configuration stored in a read-only memory. Information cannot be altered or reprogrammed.
FGU	Frequency Generation Unit.
GaAs	Gallium Arsenide: a type of crystalline material used in some semiconductors.
ISW	Inbound Signalling Word: data transmitted on the control channel from a subscriber unit to the central control unit.
LCD	Liquid Crystal Display: a module used to display the radio's current operating channel or system and scan status.
LD MOS	Lateral Diffusion MOS.
LH DATA	Longhorn Data: a bidirectional 0-5V, RS-232 line that uses the microcontroller's integrated RS-232 asynchronous serial communications interface (SCI) peripheral.
LLE	Low Level Expander: slight amount of volume expansion; used to improve the signal to noise ratio.
LSH	Low-Speed Handshake: 150 baud digital data sent to the radio during trunked operation while receiving audio.
LTR	Trunked signaling protocol using low speed data. Registered trademark of E.F. Johnson Company.
MDC	Motorola Digital Communication.

MRTI	Motorola Radio-Telephone Interconnect: a system that provides a repeater connection to the Public Switched Telephone Network (PSTN). The MRTI allows the radio to access the telephone network when the proper access code is received.
MSK	Minimum-Shift Keying.
OMPAC	Over-Molded Pad-Array Carrier: a Motorola custom package, distinguished by the presence of solder balls on the bottom pads.
OSW	Outbound Signalling Word: data transmitted on the control channel from the central controller to the subscriber unit.
PassPort®	Enhanced trunking protocol developed by Trident Datacomm Technologies, Inc. that links wide area dispatch networking.
PC Board	Printed Circuit Board.
PL	Private-Line® tone squelch: a continuous sub-audible tone that is transmitted along with the carrier.
PLL	Phase-Locked Loop: a circuit in which an oscillator is kept in phase with a reference, usually after passing through a frequency divider.
PPM	Parts Per Million.
PTT	Push-To-Talk: the switch located on the left side of the radio which, when pressed, causes the radio to transmit.
RAM	Random Access Memory: the radio's RAM is loaded with a copy of the EEPROM data.
Registers	Short-term data-storage circuits within the microcontroller.
Repeater	Remote transmit/receive facility that retransmits received signals to improve communications coverage.
RESET	Reset line: an input to the microcontroller that restarts execution.
RF PA	Radio Frequency Power Amplifier.
RIB	Radio Interface Box.
ROM	Read Only Memory.
RSSI	Received Signal-Strength Indicator: a dc voltage proportional to the received RF signal strength.
RPT/TA	Repeater/Talk-Around.
Softpot	Software Potentiometer: a computer-adjustable electronic attenuator.
Software	Computer programs, procedures, rules, documentation, and data pertaining to the operation of a system.
SPI (clock and data lines)	Serial Peripheral Interface: how the microcontroller communicates to modules and ICs through the CLOCK and DATA lines.
Squelch	Muting of audio circuits when received signal levels fall below a pre-determined value.

Standby Mode	An operating mode whereby the radio is muted but still continues to receive data.
System Central Controller	Main control unit of the trunked dispatch system; handles ISW and OSW messages to and from subscriber units (see ISW and OSW).
System Select	The act of selecting the desired operating system with the system-select switch (also, the name given to this switch).
TOT	Time-Out Timer: a timer that limits the length of a transmission.
TPL	Tone Private-line.
μC	Microcontroller.
UHF	Ultra High Frequency.
μP	Microprocessor.
VCO	Voltage-Controlled Oscillator: an oscillator whereby the frequency of oscillation can be varied by changing a control voltage.
VCOBIC	Voltage-Controlled Oscillator Buffer Integrated Circuit.
VHF	Very High Frequency.
VSWR	Voltage Standing Wave Ratio.



Motorola, Intelligence Everywhere, Professional Radio are trademarks of Motorola, Inc.
LTR is a registered trademark of E.F. Johnson Company.
PassPort is a registered trademark of Trident Datacom Technologies, Inc.
All other product or service names are the property of their respective owners.
© 2002 Motorola, Inc. All rights reserved. Printed in U.S.A.



6864110R15-O