

 **MOTOROLA**
test equipment

**COMMUNICATIONS
SYSTEM ANALYZER**

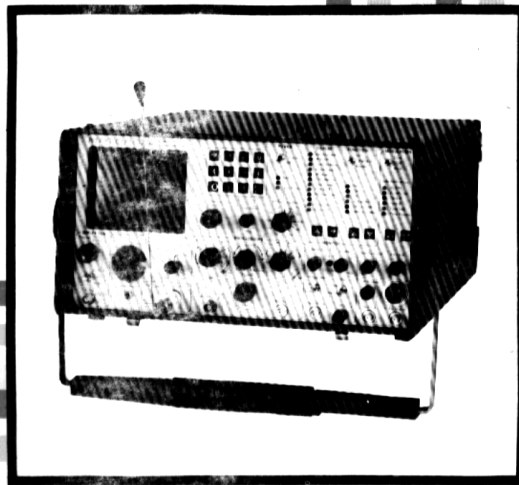

R-2001C/R-2002C

68P81069A99-O

Communications
Group

R-2001C/R-2002C COMMUNICATIONS SYSTEM ANALYZER

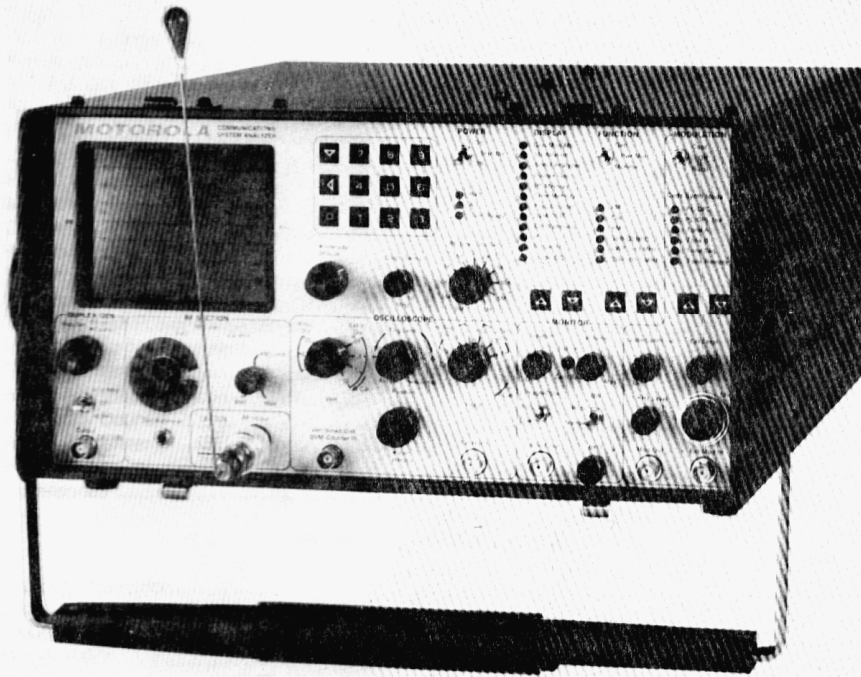

82-2948

8486-10

© Motorola, Inc. 1982
All Rights Reserved
Printed in U.S.A.

1313 E. Algonquin Road, Schaumburg, Il. 60196

68P81069A99-O
12/1/82-SK

FOREWORD

1. SCOPE OF MANUAL

This manual contains information for the installation, operation, and maintenance of the Communications System Analyzer.

2. PURPOSE AND USE

The Motorola Communications System Analyzer is a portable test instrument, designed specifically for the service and monitoring of communications equipment. Its functions supersede those of a Service Monitor, expanding the features and capabilities to the point wherein servicing is achieved with a single instrument, rather than a host of separate equipment.

The R2001C is the standard Communications System Analyzer. The R2002C Analyzer, which contains the IEEE-488 Standard interface control bus, is also available. Programming for the R2002C is covered in Section 21 of this manual.

The Analyzer improves a technician's efficiency and accuracy and reduces servicing time.

The Communications System Analyzer performs the functions of signal generation, signal monitoring and the tests normally associated with the devices listed below.

- Spectrum Analyzer
- Duplex Generator
- Modulation Oscilloscope
- Frequency Counter
- AC/DC Digital Voltmeter
- RF Wattmeter
- General Purpose Oscilloscope
- Multi-Mode Code Synthesizer
- Distortion/SINAD Meter
- Sweep Generator

The Analyzer meets the shock and vibration requirements of EIA test RS152B, the same specifications met by Motorola mobile radios. This minimizes failure when the instrument is used in a mobile service van, and means it is as tough as the radios it services.

The Communications System Analyzer is designed to be serviced quickly and easily, should a breakdown occur. The majority of the circuitry is on twelve modular plug-in circuit boards which have built-in test points that aid in isolating the problem to a specific board. Simple plug-in replacement gets the instrument back in service.

CAUTION

This equipment contains parts that are subject to damage by static electricity. Proper precautions should be taken during handling.

WARNING

Lithium Battery

The processor module within this system utilizes a lithium battery as a memory keep-alive voltage source. Do not mutilate or disassemble the battery cell. The lithium metal is a very active material that burns in the presence of water or high humidity. Do not put the battery in fire, attempt to charge, heat above 100°C, or solder directly to the cell. Do not overdischarge the cell to a reverse voltage greater than 3 volts. The battery may burst and burn or release hazardous materials. See section 5-143 of this manual for battery troubleshooting procedures and cautions.

CAUTION

Lithium Battery

Lithium batteries are classified as hazardous materials and must be disposed of accordingly. Do not dispose of the battery by placing it in with the everyday trash. Consult state and local codes for the appropriate disposal procedure. Motorola will dispose of the battery if the expended battery is returned in the replacement battery container and by the same method that the new battery came to you, send to: Motorola Inc., Return Goods Department, 1313 East Algonquin Road, Schaumburg, Ill. 60196.

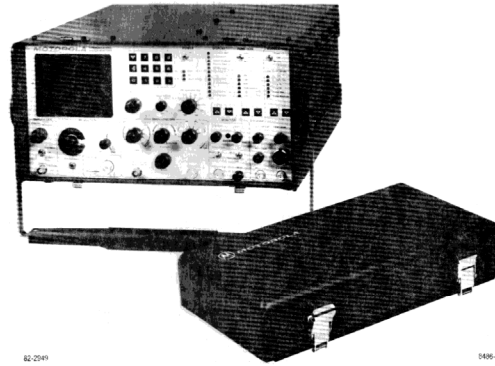

Figure 1-1. Communications System Analyzer

TABLE OF CONTENTS

Paragraph		Page
	FOREWORD	1
SECTION 1		
1-1	Introduction	1-1
SECTION 2 — DESCRIPTION		
2-1	Description	2-1
2-3	Microprocessor	2-1
2-4	Display	2-1
2-5	System Warnings	2-1
2-6	Functions	2-2
2-7	AM, FM, CW, DSB Signal Generation	2-2
2-8	Simultaneous Modulation	2-2
2-9	Modulation Display	2-2
2-10	Sweep Generation	2-2
2-11	SINAD Metering	2-2
2-12	Multi-Mode Code Synthesizer	2-2
2-13	Off-The-Air Monitor	2-2
2-14	IF Display	2-2
2-15	Spectrum Analyzer	2-2
2-16	RF Burnout Protection	2-3
2-17	Terminated RF Power Measurement	2-3
2-18	In-Line Power Measurement	2-3
2-19	Duplex Generator	2-3
2-20	500-kHz Oscilloscope	2-3
2-21	Frequency Counter	2-3
2-22	AC/DC Voltmeter	2-3
2-23	Power Supply	2-4
2-24	Accessories	2-4
SECTION 3 — INSTALLATION		
3-1	Packing Information	3-1
3-4	Initial Setup	3-1
3-5	Analyzer	3-1
3-6	Battery Pack	3-2
SECTION 4 — OPERATION		
4-1	General	4-1
4-3	Controls, Indicators, and Connectors	4-1
4-5	Operation	4-12
4-7	Calibrate	4-12
4-8	Generator Operation	4-13
4-9	Duplex Generation	4-13
4-10	Frequency Counter	4-14
4-11	Spectrum Analyzer	4-14

4-12	Monitor	4-15
4-13	Ext Wattmeter	4-16
4-14	Simultaneous Generate and Measurement Operations	4-17

SECTION 5 — MAINTENANCE

5-1	Service	5-1
5-6	Replacement Parts Ordering	5-1
5-9	Addresses	5-1
5-10	General Offices	5-1
5-11	U.S. Orders	5-2
5-12	Canadian Orders	5-2
5-13	All Countries Except U.S. and Canada	5-2
5-14	Major Assemblies	5-3
5-16	Theory of Operation	5-5
5-17	General	5-5
5-20	System Control	5-9
5-25	Generate Mode	5-9
5-34	Power Meter	5-12
5-40	Monitor Mode	5-13
5-52	Duplex Generator	5-14
5-56	Code Synthesizer	5-15
5-65	Frequency Counter	5-17
5-71	Digital Voltmeter (DVM)	5-18
5-82	Distortion/SINAD Meter	5-19
5-84	Oscilloscope	5-19
5-96	Alignment Procedure	5-21
5-97	Introduction	5-21
5-99	Test Equipment Required	5-21
5-101	Preparation for Alignment	5-22
5-102	Basic Alignment Procedure	5-22
5-115	Extended Alignment Procedure	5-26
5-118	Distortion/SINAD Alignment	5-29
5-123	Checkout Procedure	5-30
5-124	Introduction	5-30
5-126	Test Equipment Required	5-31
5-128	Procedure	5-31
5-143	System Troubleshooting	5-35

SECTION 6 — SYSTEM INTERCONNECT AND PARTS LISTS

SECTION 7 — LOW VOLTAGE POWER SUPPLY (A1)

7-1	General	7-1
7-2	Input Power Control	7-1
7-6	DC Output Control	7-1
7-9	Protection Circuitry	7-1
7-13	High Voltage Supply Control	7-2
7-14	Switcher Module A1A1	7-2
7-17	Output Module A1A2	7-2
7-21	Control Module A1A3	7-3
7-24	Relay Module A1A4	7-3

SECTION 8 — SCOPE AMPLIFIER (A2)

8-1	General	8-1
8-2	Deflection Amplifiers	8-1
8-3	Horizontal Timebase Generator	8-1
8-5	Horizontal Switching	8-1
8-6	Intensity Control	8-1
8-8	Focus Control	8-1
8-9	Astigmatism, Geometry, and Trace Rotation	8-1

SECTION 9 — SCOPE/DVM CONTROL MODULE (A3)

9-1	General	9-1
9-4	Scope Vertical Control	9-1
9-7	SSB Detection	9-1
9-8	455 kHz PLL	9-1
9-9	Scope Horizontal Control	9-2
9-11	Synthesizer Sweep Control	9-2
9-12	Scope Z-Axis Control	9-2
9-13	Modulation Display Control	9-2
9-17	Peak Detector	9-2
9-18	DVM Control	9-2
9-21	External DVM/Distortion Control	9-3
9-22	Distortion Measurement	9-3
9-23	External DVM Measurement	9-3
9-24	Module Control	9-3

SECTION 10 — RECEIVER (A4)

10-1	General	10-1
10-2	Down Converter	10-1
10-4	Linear IF Amplifier and Detectors	10-1
10-8	Audio Switching and Filtering	10-1
10-10	Logarithmic Amplifier and Detector	10-2
10-11	Alarm Generator and Audio Amplifier	10-2
10-12	Module Control	10-2

SECTION 11 — RF SYNTHESIZER (A5)

11-1	General	11-1
11-2	Frequency Synthesis Scheme	11-1
11-5	310-440 MHz Phase Locked Loop	11-1
11-6	60.5 MHz Phase Locked Loop	11-1
11-7	550 MHz Phase Locked Loop	11-1
11-9	500-1000 MHz Phase Locked Loop	11-1
11-10	Modulation Control	11-2
11-11	Module Control	11-2

SECTION 12 — AUDIO SYNTHESIZER (A6)

12-1	General	12-1
12-2	Private Line Generator	12-1
12-7	DPL Generator	12-1
12-10	1 kHz Tone	12-2

12-11	External Modulation.....	12-2
12-12	Modulation Control.....	12-2
12-14	Module Control.....	12-2
SECTION 13 — PROCESSOR I/O MODULE (A7)		
13-1	General.....	13-1
13-2	10.245 MHz Phase Locked Loop.....	13-1
13-3	System Control Bus Interface.....	13-1
13-6	A/D Converter.....	13-1
13-7	External DVM.....	13-2
13-10	Internal DVM.....	13-2
13-11	Distortion Reading.....	13-2
13-12	Frequency Counter.....	13-2
SECTION 14 — IEEE INTERFACE MODULE (A8)		
14-1	General.....	14-1
14-2	IEEE Bus Interface.....	14-1
14-3	RF Level Control.....	14-1
14-5	Modulation Control.....	14-1
14-6	Address Decode and Control Latches.....	14-1
SECTION 15 — PROCESSOR MODULE (A9)		
15-1	General.....	15-1
15-2	Processor and Buffer.....	15-1
15-3	Program Memory (ROM).....	15-1
15-4	Nonvolatile Memory (NVM).....	15-1
15-5	Random Access Memory (RAM).....	15-1
15-6	Peripheral Interface Adapter (PIA).....	15-1
15-7	Timing Generator.....	15-1
15-8	Character Generator.....	15-1
SECTION 16 — HIGH VOLTAGE POWER SUPPLY (A10)		
16-1	General.....	16-1
16-2	High Voltage Supply.....	16-1
SECTION 17 — RF INPUT MODULE (A11)		
17-1	General.....	17-1
17-2	Input Protection and Power Meter.....	17-1
17-4	Wideband Amplifier and Frequency Converter.....	17-1
17-9	Duplex Generator.....	17-2
SECTION 18 — FRONT PANEL INTERFACE MODULE (A12)		
18-1	General.....	18-1
18-2	Input Coupling and Ranging.....	18-1
18-4	DVM Buffer.....	18-1
18-5	Frequency Counter Preamp.....	18-1
18-6	Scope Vertical Preamp.....	18-1
18-7	Scope Horizontal Preamp.....	18-1
18-8	Control and Display Interface.....	18-1

SECTION 19 — 10 MHz FREQUENCY STANDARD MODULE (A13)

19-1 General..... 19-1

SECTION 20 — FRONT PANEL (A14)

20-1 General..... 20-1
20-2 Display Board..... 20-1

SECTION 21 — IEEE-488 BUS CONTROL

21-1 Introduction 21-1
21-7 IEEE-488 Bus Structure 21-3
21-9 Bus Signals 21-3
21-10 Data Transfer 21-3
21-12 Programming 21-3
21-15 Command Structure 21-4
21-24 Command Strings 21-7
21-25 Command Types 21-7
21-29 Trigger Command 21-7
21-30 Return Data 21-7
21-35 Programming Commands 21-8
21-36 Terminal Mode 21-8
21-42 Error Messages 21-8
21-45 Service Requests 21-10
21-46 Programming Considerations 21-11
21-53 General 21-12
21-54 R2002C Analyzer Configuration 21-12

SECTION 22 — BATTERY ASSEMBLY

LIST OF ILLUSTRATIONS

Figure		Page
1-1	Communications System Analyzer	1-0
2-1	Accessories Supplied with Analyzer	2-4
3-1	Typical Communication System Analyzer Packaging.....	3-1
4-1	Controls, Indicators, and Connectors, Front Panel.....	4-2
4-2	Controls, Indicators, and Connectors, Left Side Panel	4-3
4-3	Controls, Indicators, and Connectors, Rear Panel	4-3
4-4	System Analyzer Time Base Calibrate Test Setup and CRT Display	4-12
4-5	Duplex Generation Test Setup and CRT Display	4-14
4-6	Spectrum Test Setup and CRT Display.....	4-15
4-7	Wattmeter Test Setup and CRT Display.....	4-16
4-8	Test Setup for FM Receiver Sensitivity Using Generator and SINAD Meter with CRT Display	4-17
4-9	Test Setup for Two-Tone Pager and Alert Functions with CRT Display	4-18
4-10	Test Setup for 5/6 Tone Pager with CRT Display.....	4-19
4-11	Test Setup for Mobile Telephone Test with CRT Display.....	4-20
4-12	Test Setup for Select V Test with CRT Display.....	4-12
4-13	Test Setup for Using DVM and Signal Generate with CRT Display	4-21
5-1	Communication System Analyzer, Top View Cover Removed	5-4
5-2	Communication System Analyzer, Bottom View Cover Removed.....	5-5
5-3	Communication System Analyzer Block Diagram.....	5-7
5-4	Generate Mode Block Diagram	5-11
5-5	Power Meter Block Diagram.....	5-12
5-6	Monitor Mode Block Diagram.....	5-13
5-7	Duplex Generator Block Diagram	5-15
5-8	Code Synthesizer Block Diagram.....	5-16
5-9	Frequency Counter Block Diagram.....	5-17
5-10	Digital Voltmeter (DVM) Distortion Analyzer	5-18
5-11	Oscilloscope Block Diagram.....	5-20
5-12	Scope Amplifier Alignment Points	5-24
5-13	Front Panel Interface Alignment Points	5-24
5-14	Scope/DVM Control Alignment Points	5-25
5-15	Horizontal Time Base Alignment Points	5-26
5-16	Processor I/O A/D Alignment Points	5-28

LIST OF TABLES

Table		Page
1-1	Physical Characteristics	1-1
1-2	Electrical Characteristics	1-1
1-3	Input/Output Characteristics	1-5
2-1	Accessories Supplied with the Communication Systems Analyzer	2-4
2-2	Optional Equipment for Use with Analyzer	2-5
4-1	Controls, Indicators, and Connectors	4-1
5-1	List of Subassemblies	5-3
5-2	Control Buses and Functions	5-10
5-3	Basic Test Equipment Required	5-21
5-4	Extended Test Equipment Required	5-21
5-5	Test Equipment	5-31
5-6	System Troubleshooting	5-35
5-7	Test Point Identification	5-42
7-1	Control Logic Functions	7-3
9-1	Internal DVM Inputs	9-3
21-1	IEEE-488 Interface Controllable Functions	21-2
21-2	Command Categories	21-4
21-3	Programming Commands	21-5
21-4	Terminal Mode ASC II Characters Printable Characters	21-9
21-5	Error Messages	21-10
21-6	SRQ Data	21-10
21-7	Code Synthesizer Programming Considerations	21-11

SECTION 1

1-1. INTRODUCTION

1-2. This section lists the physical, electrical, and input/output characteristics of the Communications System Analyzer shown in figure 1-1.

Table 1-1. Physical Characteristics

Characteristics	Description
Length	20.75 inches (52.7 cm)
Width	13.75 inches (40.0 cm)
Height	8.25 inches (21.0 cm)
Weight	48 pounds (21.9 kg) (Excluding Battery Pack)

Table 1-2. Electrical Characteristics

Characteristics	Description
Signal Generator Mode	
Frequency	10 kHz to 999.9999 MHz
Range:	100 Hz
Resolution:	Equal to master oscillator time base
Accuracy:	
Output (into 50 ohms)	16 dB variable plus 10 dB steps over 13 ranges
Attenuator:	0.1 μ V to 1 Vrms (-127 dBm to +13 dBm)
Range:	\pm 2 dB accuracy on 0 dB step attenuator range
Accuracy:	\pm 2 dB across other step attenuator ranges
	\pm 1 dB over temperature range
Spectral purity	
Spurious:	\leq -40 dB
Harmonics:	\leq -15 dB
Frequency modulation	
Range:	0 - 50 kHz peak
Accuracy:	\pm 5% of full scale
FM residual noise:	100 Hz
External/internal frequency range:	5 Hz - 10 kHz (\pm 1 dB)
External input:	Approximately 150 mV for 20 kHz deviation
Modes:	Internal, external, microphone or all simultaneously

1-1

Table 1-2. Electrical Characteristics (Cont)

Characteristics	Description
General Spectrum Analyzer	
Dynamic range	$>$ 75 dB displayed, -105 dBm to -30 dBm input range with step attenuator
Frequency	4 MHz to 1,000 MHz
Range:	Adjustable between 1 MHz and 10 MHz
Full scale frequency dispersion:	
Duplex Generator	
Frequency offset	Adjustable from 0 to 10 MHz plus fixed offset of 45 MHz (high or low side)
Modulation level (FM only)	Adjustable from 0 to 20 kHz peak deviation
Oscilloscope	
Size	8 cm \times 10 cm
Frequency response	DC to 0.5 MHz (3 dB point)
External vertical input range	10 mV, 100 mV, 1V, 10V (per division)
Sweep rates	1 μ s, 10 μ s, 0.1 ms, 1 ms 0.01S, 0.1S (per division)
Sync	Automatic, normal and delayed triggering. Delayed triggering is programmable to 10 seconds in 1 ms steps and works in conjunction with the code synthesizer. See "CAUTION" note on page 4-19
Frequency Counter	
Frequency range	10 Hz to 35 MHz
Readout:	5 digit, autorange
Input sensitivity:	30 mV from 10 Hz to 1 MHz 50 mV from 1 MHz to 35 MHz
Digital Voltmeter	
Readout:	Auto ranging digital display, 1, 10, 100, 300 volts full scale. AC-dBm calibrated across 600 ohms.
DC accuracy:	\pm 1% of full scale \pm 1 least significant digit
AC accuracy:	\pm 5% of full scale
AC bandwidth:	50 Hz to 10 kHz
Modulation Source	
Code Synthesizer	
Frequency range:	5 Hz to 9.9999 kHz sinewave
Resolution:	0.1 Hz
Frequency accuracy:	\pm 0.01%
Distortion:	$<$ 1%

1-3

Table 1-2. Electrical Characteristics (Cont)

Characteristics	Description
Amplitude modulation	0 to 80% from 1 to 500 MHz
Range:	\pm 10% of full scale from 0% to 50% AM
Accuracy:	5 Hz - 10 kHz (\pm 1 dB)
External/internal frequency range:	Internal, external, microphone or all simultaneously
Modes:	
Double sideband suppressed carrier	
Carrier suppression:	\geq 25 dB (1 MHz - 500 MHz)
Monitor Mode	
Frequency	1 MHz to 999.9999 MHz
Range:	100 MHz
Resolution:	Equal to that of master oscillator time base
Accuracy:	
Frequency error indicator	Autorangeing CRT display. \pm 10 Hz resolution for frequency error measurements on 1.5 kHz, 5 kHz and 15 kHz full scale ranges. \pm 1 Hz resolution on the 50 Hz full scale range.
Input sensitivity	1.5 μ V for 10 dB EIA Snad (narrow band \pm 6 kHz mod. acceptance) 7 μ V for 10 dB EIA Snad (wide band \pm 100 kHz mod. acceptance) 4 MHz to 1000 MHz. Useable to 1 MHz.
Spurious response	-40 dB typical 0 dB image at \pm 21.4 MHz -10 dB at L.O. harmonics \pm 10.7 MHz
Deviation Measurement	1, 10, 100 kHz full scale \pm 5% of reading \pm 100 kHz from 500 Hz to 50 kHz deviation; \pm 10% of reading from 50 kHz to 75 kHz deviation Set via keyboard to 100 Hz resolution (0.1 kHz to 99.9 kHz). Audible alarm indicates limit condition in all Monitor Modes. 00.0 setting disables the alarm.
Peak deviation limit alarm:	
AM modulation measurement	0 to 100% \pm 5% of full scale
Range:	
Accuracy:	
RF Wattmeter (Autorangeing display)	
Frequency range:	1 MHz to 1000 MHz
Power range:	1.0 watts to 125 watts
Accuracy:	\pm 10%, 1 watt to 125 watts
Protection:	Over temp indicator

1-2

Table 1-2. Electrical Characteristics (Cont)

Characteristics	Description
Signaling Sequences	
Two Tone A/B	Tone Only Sequence Tone and Voice Sequence Two user programmable (See figure 1-2 for sequence timing)
5/6 Tone	Digit Frequencies (See figure 1-3 for sequence timing)
	0 - 600 Hz 1 - 741 Hz 2 - 882 Hz 3 - 1023 Hz 4 - 1164 Hz 5 - 1305 Hz 6 - 1446 Hz 7 - 1587 Hz 8 - 1728 Hz 9 - 1869 Hz R - 459 Hz X - 2010 Hz
Mobile Telephone	
IMTS	(See figure 1-4 for sequence timing)
MTS	(See figure 1-5 for sequence timing)
2805	(See figure 1-6 for sequence timing)
Select V	Tone length - 70ms
ZVEI	Digit Frequencies
	1 - 1060 Hz 2 - 1160 Hz 3 - 1270 Hz 4 - 1400 Hz 5 - 1530 Hz 6 - 1670 Hz 7 - 1830 Hz 8 - 2000 Hz 9 - 2200 Hz 0 - 2400 Hz R - 2600 Hz
Modified ZVEI	Tone length - 70 ms Digit Frequencies
	1 - 970 Hz 2 - 1060 Hz 3 - 1160 Hz 4 - 1270 Hz 5 - 1400 Hz 6 - 1530 Hz 7 - 1670 Hz 8 - 1830 Hz 9 - 2000 Hz 0 - 2200 Hz R - 2400 Hz

1-4

Table 1-3. Input/Output Characteristics (Cont)

Characteristic	Description
Output	
Mod out	Up to 11 vpp into 600 ohms 10 Hz to 10 kHz
Demod out	Typically 3 vpp into 600 ohms for ± 5 kHz deviation narrowband.
RF in/out	4 vpp for ± 75 kHz deviation wideband. DC to 10 kHz response
Duplex gen out	1.0 Vrms (+ 13 dBm) to 0.1 μ Vrms (-127 dBm) 50 ohm nominal source impedance. 10 kHz to 1.0 GHz.
10 MHz std out (rear panel)	- 30 dBm typical, 50 ohm nominal source impedance 2 MHz to 1 GHz
	250 mV rms nominal output into 50 ohms

SECTION 2 DESCRIPTION

2-1. DESCRIPTION

2-2. The Communication System Analyzer is a portable test instrument designed for servicing and monitoring of portable, mobile, and land base communications equipment operating over the frequency range of 1 MHz to 1 GHz. The unit performs the functions of signal generation, frequency error and modulation measurement. It is also capable of a variety of tests normally associated with the following devices:

- Spectrum analyzer
- Duplex offset generator
- Modulation oscilloscope
- Frequency counter
- AC/DC digital-analog voltmeter
- RF wattmeter
- General purpose oscilloscope
- Multi-mode code synthesizer
- Distortion/SINAD meter
- Sweep generator

2-3 MICROPROCESSOR. A Motorola M-6800 series microprocessor permits keyboard entry of data, autoranging of displays, fast frequency access, and permanent storage of often-used frequencies and codes. Generate and monitor RF frequencies, tone codes, and timing sequences can be programmed into a nonvolatile memory, saving time and eliminating entry errors. When one particular type of equipment is continuously serviced, the unit can be programmed to select the mode of operation required when first turned on.

2-4. DISPLAY. All functions, generated or monitored, are presented on an 8 cm x 10 cm cathode ray tube (CRT) in both analog and digital format, with the name of the function being displayed. The CRT also displays control settings eliminating the need for operator search of different equipment panels. Digital readouts are visually aided by the use of the continuously autoranging analog line segments, which are similar to a bar graph. Each has a base line and calibration markers, in addition to the intensified segment showing the measurement. The user selectable displays are listed in a column beneath the DISPLAY heading on the front panel. Choosing a display is accomplished by pressing an arrow button below the column, for up or down movement, as required. When the appropriate arrow is pressed, the LED adjacent to the selected display illuminates. FUNCTION is selected in the same way, providing rapid, accurate changes in service capability at the touch of a button.

2-5. SYSTEM WARNINGS. To aid the technician in servicing, visual warnings will appear on the CRT when certain overload or caution conditions exist. Displays warn of low battery power, overheating of the RF load, or an improper attenuator setting for particular measurements. In addition, a continuous audible alarm sounds when a preset deviation limit is exceeded in monitor modes. This limit is entered by using the keyboard and may be programmed from 0.1 KHz to 99.9 kHz, with 100 Hz resolution.

2-23. Power Supply. The Communications System Analyzer may be powered by a variety of sources:

- AC at 110 or 220 Volts, 50, 60 Hz
- DC from an external 12 Volt source such as a service vehicle
- DC from an optional battery pack. Servicing can thus be accomplished wherever the equipment under test is located.

2-24. ACCESSORIES.

2-25. Figure 2-1 illustrates and Table 2-1 lists the accessories supplied with the Communication System Analyzer. Optional equipment available for use with the unit is listed in Table 2-2.

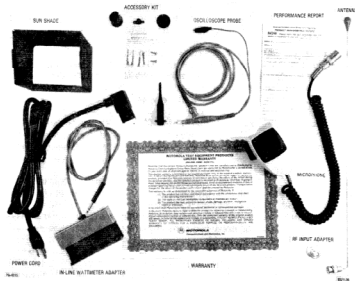

Figure 2-1. Accessories Supplied with Analyzer

Table 2-1. Accessories Supplied with the Communication Systems Analyzer

Equipment	Motorola Part No.	Use
Front cover	15-80335A70	Front panel and CRT protection, storage of cables, power cord, and other equipment for on-site servicing.
Sun shade	15-80335A55	Snap over CRT during use in bright sunlight.
Power cord	30-80336A36	Three conductor cord to supply AC power to unit. Also used when charging optional battery pack.
Oscilloscope probe	RTL-4058A	A X1 probe with attachments for general servicing.
In-line wattmeter adapter	RTL-4055B	Allows use of Motorola ST-1200 series in-line wattmeter elements for direct measurement and display of forward and reflected transmitted power.
Coax adapter	58-84300A98	Adapts front panel "N" connector to BNC female.
Antenna	TEKA-24A	Plugs into RF in/out connector on front panel, with N to BNC adapter. Used for off-the-air transmitter and receiver tests.
Test microphone	RTM-4000A	Used for voice modulation of signals.
Connector kit	RPX-4097A	Consists of connector shell, clamp, and four connector pins. Used to fabricate a mating plug for male dc power connector at back of analyzer. Enables user to make a dc power cable to interconnect separate power source to analyzer. Pins 1 and 2 are positive, pin 3 is the charging line, pin 4 is ground.

Table 2-2. Optional Equipment for Use with Analyzer

Equipment	Motorola Part No.	Use
IEEE-488 Standard interface bus option	Consult factory for retrofit information.	Enables fully automatic testing with the unit by external control from a computer or programmable controller.
Battery pack	RTP-1002A	13.6 volt battery and charger attaches to back of the unit. Provides one hour of continuous operation. Cannot be used with IEEE-488 option.
High-stability oscillator module	RTL-1007A	Improves stability of the time base as specified in electrical characteristics section.
Protective cover	RTL-4056A	Padded fabric type cover to protect unit from excessive field wear.

SECTION 3 INSTALLATION

3-1. PACKING INFORMATION

3-2. The unit is packaged in a fiberboard carton and protected by foam pieces as shown in figure 3-1. The unit is first packed in a cardboard container and then this carton is packed in a second, larger cardboard container, for further protection. Save the packing container and materials for future use.

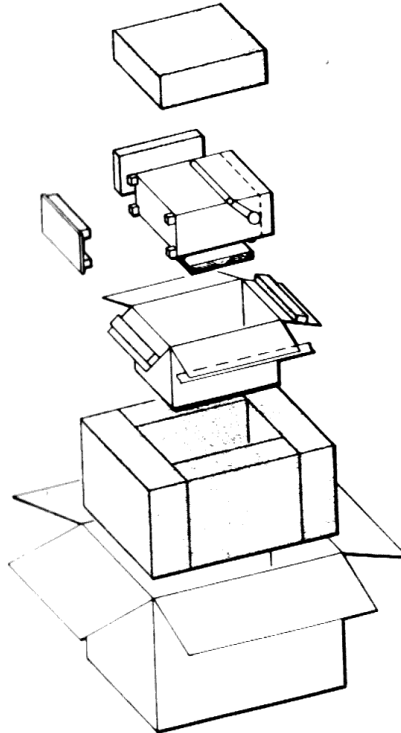

Figure 3-1. Typical Communication System Analyzer Packaging

3-3. All accessories supplied with the analyzer are packed in the analyzer cover.

3-4. INITIAL SETUP

3-5. ANALYZER. To set up the Analyzer for use, place the unit on workbench or in mobile repair unit. Remove the front cover by operating the two latches on the bottom of the cover. Lift the cover and slide it to the side to separate the hinges. Remove the power cord (AC or DC) that is stored in the cover. Attach the female connector of the power cord to the appropriate connector on the rear panel of the analyzer, and the other end to the power source. For AC power a grounded 3 wire power source of 100-130 Vac or 200-260 Vac, 47-63 Hz must be used.

NOTE

The unit is set for 110-130 Vac operation from the factory. For operation from 100-110 Vac or 200-260 Vac, the voltage selection card must be readjusted before connection to the power source. This is accomplished by the following procedure:

1. Remove the power cord from the rear panel connector.
2. Slide the selector card cover door over the connector area exposing the selection card and fuse area.
3. Pull outward on the fuse ejector tab and remove fuse.
4. Remove the printed circuit board voltage selector card by pulling straight to the rear.
5. Reinsert the card at the orientation which causes the appropriate voltage range (marked on card) to be displayed.
6. Install the proper fuse (1.5A for 100-130 VAC, 0.75A for 200-260 VAC).
7. Slide the cover plate back to the original position, connect power cord, and proceed with system operation.

Remove the accessories to be used from the cover. Move the **POWER** switch to the ON position. When the Oven Ready indicator illuminates the unit's frequency standard is stabilized and the unit is ready for use, (instantaneous with standard TCXO).

CAUTION

When installing the analyzer in a vehicle, the DC supply line should be fused close to the vehicle battery. The analyzer is protected against overload by the DC-8A fuse on the rear of the unit, but the vehicle is not protected.

3-6. BATTERY PACK. The battery pack is attached to the rear of the analyzer with two clips and two screws. Align and slide the mounting clips of the battery pack into the slots on the mounting brackets on the left side of the back panel of the analyzer. Align the captive screws with the mounting holes on the right of the panel and tighten. Connect the power plug to the connector at the top right of the rear panel.

SECTION 4 OPERATION

4-1. GENERAL

4-2. This section contains information for the operation of the Communication System Analyzer.

4-3. CONTROLS, INDICATORS, AND CONNECTORS

4-4. The analyzer controls, indicators, and connectors are shown in Figures 4-1 through 4-3 and listed with their functions in Table 4-1.

Table 4-1. Controls, Indicators, and Connectors

Item	Description	Function
FRONT PANEL (fig. 4-1)		
Keyboard	Twelve-key pushbutton keyboard	Enters variables into memory/enters manual variables/ selects variables to be used from the memory.
▽	Line cursor key	Moves the cursor down to the next line that may be changed. Preset permanent entries are skipped. Cursor will move down only. When on last line, will return to top line with next entry.
◀	Horizontal cursor key	Moves the horizontal cursor left to the next entry position that may be changed. When in the last left position, the cursor will move to the far right with the next entry.
0 through 9	Numerical keys	Used to select from the memory a stored value to be used, or to enter directly a value to be used.
<ul style="list-style-type: none"> ● Intensity ● Focus 	Stacked concentric potentiometers <ul style="list-style-type: none"> ● Intensity - center (small) knob ● Focus - outside (large) knob 	Controls the intensity of the scope presentation. Controls the focus of the scope presentation.
Dispr/Sweep control	Potentiometer	Controls the frequency span (1-10 MHz) displayed on the CRT when unit is used as a spectrum analyzer. Provides sweep width control when either sweep function (SWP 0.01-1 MHz or SWP 1-10 MHz) is selected.

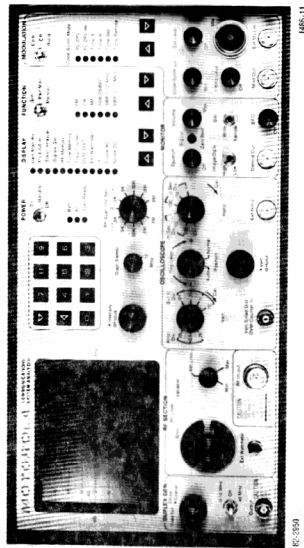

Figure 4-1 Controls, Indicators, and Connectors, Front Panel

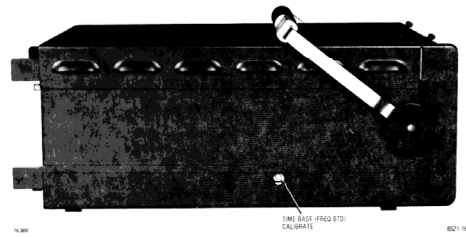

Figure 4-2 Controls, Indicators, and Connectors, Left Side Panel

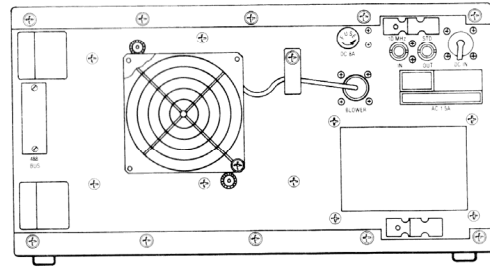

Figure 4-3 Controls, Indicators, and Connectors, Rear Panel

4-2

Table 4-1 Controls, Indicators, and Connectors (Cont)

Item	Description	Function
FRONT PANEL (fig. 4-1)		
RF Scan (Hz/Sec) switch	Eleven position switch	Allows automatic scan of the generated or the monitored frequency. The switch setting indicates rate of frequency change. The rate is 5 steps per second, with frequency steps of 100 Hz, 1 kHz, 10 kHz, 100 kHz and 1 MHz.
POWER switch	Three-position toggle switch.	<p>a. Energizes all circuitry in the On position.</p> <p>b. At Standby position, removes DC from all circuitry except the frequency standard and battery charger.</p> <p>c. At Off, only the battery charging circuitry is operative if an ac power source is being used.</p>
Batt indicator	LED (red)	Illuminates when equipment is using DC power.
AC indicator	LED (red)	Illuminates when equipment is connected to an ac power source. Position of POWER switch has no effect on indicator. Equipment automatically switches to ac power source when connected to ac line voltage.
Oven Ready indicator	LED (red)	Illuminates when optional frequency standard oven has stabilized. Continuously illuminated with the TCXO frequency standard.
DISPLAY indicators	Twelve LEDs (red)	<p>Illuminate one at a time to indicate the function or type of operation the equipment is performing and the information displayed on the CRT.</p> <p>a. Gen/Mon Mtr — In the generate mode the center frequency, output power, and modulation depth of the RF output is displayed. In the monitor mode the center frequency, input power, frequency error, and modulation depth of the received carrier is displayed.</p> <p>b. Modulation — The modulation audio in the generate mode or the demodulated audio in the monitor mode is displayed.</p> <p>c. Spect Analyzer — The spectrum analyzer mode is enabled. The RF spectrum and the operating center frequency is displayed.</p>

4-4

4-3

Table 4-1 Controls, Indicators, and Connectors (Cont)

Item	Description	Function
FRONT PANEL (fig. 4-1)		
		<p>d. Duplex Gen — The duplex generate and monitor frequencies are displayed. The depth of modulation on the generator output or on the received carrier is indicated for the generate and monitor modes respectively. For this display, the function switch only selects which modulation reading is displayed.</p> <p>e. RF Memory — The nine stored RF frequencies or DPL codes with their corresponding PL and the current frequency in use are displayed.</p> <p>f. Tone Memory — The user selectable parameters for the code synthesizer are displayed.</p> <p>g. Freq Counter — The frequency of the signal input to the front panel frequency counter jack is displayed.</p> <p>h. DVM/Dist — The true RMS AC or DC level of the signal at the front panel DVM jack is displayed. The AC or DC mode is selected with the display cursor and the keyboard. The battery voltage is also displayed.</p> <p>i. Ext Wattmeter — The external wattmeter element selected and the forward and reflected power being passed thru that element are displayed. The element select is changed by entering the appropriate range number with the keyboard.</p> <p>j. IF — The 455 kHz IF signal from the monitor receiver is displayed.</p> <p>k. Scope AC — The voltage waveform applied to the front panel vertical input is displayed. The vertical input is AC coupled.</p> <p>l. Scope DC — The voltage waveform applied to the front panel vertical input is displayed. The vertical input is DC coupled.</p>
FUNCTION switch	Three-position toggle switch	<p>Controls the function of the equipment. The mode is shown by the LEDs.</p> <p>a. Gen - equipment generates and outputs an RF signal.</p>

4-5

Table 4-1. Controls, Indicators, and Connectors (Cont)

Item	Description	Function
FRONT PANEL (fig. 4-1)		
FUNCTION indicators	Six LEDs (red)	<p>b. Pwr Mon - equipment monitors input signals with the input terminated into the internal power meter. This position must be used for inputs of 0.2 watts and greater.</p> <p>c. Monitor - equipment monitors input signals with the input terminated into the receive mixer. This position is used for "off the air" monitoring.</p> <p>Indicates the mode or type of signal the equipment is set up to monitor or generate:</p> <p>a. FM - equipment generates or monitors frequency modulated signals.</p> <p>b. CW - equipment generates an unmodulated RF signal. Monitor CW provides frequency error measurement only.</p> <p>c. AM - equipment generates or monitors amplitude modulated signals.</p> <p>d. SSB/DSBSC - equipment generates a double sideband suppressed carrier signal. NOTE: The level of the DSBSC signal generated is not calibrated, it is for use in relative measurements only. Monitor SSB mode receives SSB signals with the use of the BFO.</p> <p>e. SWP 1-10 MHz - equipment generates a sweep RF signal having a sweep width of 1 to 10 MHz, controlled by the Disp/Sweep control. Selection of Monitor Sweep has no effect, equipment remains in generate mode.</p> <p>f. SWP 0.01-1 MHz - equipment performs as in e. above except the sweep width limits are 0.01 MHz to 1 MHz.</p>
MODULATION SWITCH	Three position toggle switch	<p>Controls the Code Synthesizer modulation source. Code Synthesizer mode is shown by the LEDs.</p> <p>a. Cont - Continuous modulation signal output.</p> <p>b. Off - Turns off signal. When the mode is DPL or DPL Inv, returning the switch to Off from Cont produces a 133 Hz tone burst for a 120 ms duration.</p>

4-6

Table 4-1. Controls, Indicators, and Connectors (Cont)

Item	Description	Function
FRONT PANEL (fig. 4-1)		
DISPLAY select switches	Two-pushbutton switches	<p>Tone A and B frequencies are entered from the keyboard on the Tone Memory Display.</p> <p>Selects the function to be displayed by the equipment, as indicated by the DISPLAY LEDs.</p> <p>a. Δ - moves the selection up one step at a time</p> <p>b. ∇ - moves the selection down one step at a time</p>
FUNCTION select switches	Two-pushbutton switches	Selects the type or mode of signal the equipment will generate or monitor as indicated by the FUNCTION LEDs. Operation is the same as for the DISPLAY select switches.
Code Synth Mode select switches	Two-pushbutton switches	Selects the Code Synthesizer output mode as indicated by the CODE SYNTH MODE LEDs. Operation is the same as for the DISPLAY select switches.
Code Synth Lvl control	Potentiometer	Controls the level of Code Synthesizer for modulation or MOD Output.
Ext Level control	Potentiometer/switch	Controls modulation level of external input (microphone and other external generators). Switch at full counterclockwise position disables external modulation inputs.
Mic connector	4-pin connector	Microphone input. Provides microphone bias and PUSH TO TALK (GENERATE) connection to equipment.
Ext Mod in connector	BNC connector	External modulation signal input.
1 kHz Level control	Potentiometer/switch	Internal 1 kHz tone modulation level control. Switch at full counterclockwise position disables 1 kHz modulation tone.
Mod Out connector	BNC connector	Output connector for all modulation signals (all signals combined).
Volume control	Potentiometer	Controls speaker output level.
BW switch	Two-position switch	In either Pwr Mon or Monitor modes selects IF bandwidth. NB is \approx 6 kHz mod acceptance bandwidth. WB is \approx 100 kHz mod acceptance bandwidth. In Gen FM mode selects modulation range. 0.25 kHz dev in NB mode or 0-100 kHz dev in WB mode.

4-8

Table 4-1. Controls, Indicators, and Connectors (Cont)

Item	Description	Function
FRONT PANEL (fig. 4-1)		
CODE SYNTH Mode indicators	Six LEDs (red)	<p>c. Burst - For PL, tone A, and tone B modes the output is present for as long as the switch is held in the burst position. For the Tone Sequence mode the burst position causes a single signaling sequence to be output. For the DPL and DPL Inv modes the Burst position causes a 133 Hz tone to be output. For the Tone Remote mode either the Burst or the Cont position causes a tone remote access sequence to be output. The access sequence leaves tone A at a low level for transmit-type commands until the switch is returned to the Off position. This switch is spring loaded to return to the Off position from the Burst position.</p> <p>When illuminated, indicates the selected mode of the Code Synthesizer</p> <p>a. PL/DPL Indicator PL - Selected Private Line frequency output to 1 kHz DPL - Selected Digital Private Line code output. Maximum code number is 777.</p> <p>b. PL/DPL Inv indicator PL - Same as above DPL - Inverted output of selected Digital Private Line code. Maximum code number is 777.</p> <p>The Private Line frequency or the Digital Private Line code is selected from the RF memory display or entered from the keyboard on the Gen Mon Mtr display.</p> <p>c. Tone A indicator Indicates Tone A selected for output</p> <p>d. Tone B indicator Indicates Tone B selected for output</p> <p>e. Tone Sequence indicator Indicates a tone signaling sequence will be output. The sequence is selectable on the Tone Memory Display. See Tone Memory Table examples Figures 4-3, 4-10, 4-11 and 4-12.</p> <p>f. Tone Remote indicator Indicates access sequence for Motorola Repeater will be output.</p>

4-7

Table 4-1. Controls, Indicators, and Connectors (Cont)

Item	Description	Function
FRONT PANEL (fig. 4-1)		
BFO control	Potentiometer/switch	BFO on/off and beat frequency control for sideband reception. Full counterclockwise position is off. NOTE: To minimize interference the BFO should be turned off when not in use.
Sig Lvl/Zero Beat indicator	LED (red)	Flashes at a rate equal to the difference between the received carrier frequency and the programmed frequency. Also is used as a squelch indicator.
Squelch control	Potentiometer	Adjusts squelch threshold level. full counterclockwise position disables squelch. NOTE: Monitor sensitivity is greatly decreased (or high-level use) as the control is increased clockwise beyond the quieting point.
Image/Dplx switch	Two-position switch	In duplex generation mode, controls the duplex frequency output for above (High) or below (Low) the receive programmed frequency. In the monitor mode it selects the frequency of the local oscillator injection above or below the programmed monitor frequency to remove image interference.
Demod Out connector	BNC connector	Receiver audio output.
Oscilloscope Horiz switch	Seven-position rotary switch	When in the oscilloscope mode, selects the horizontal sweep rate or selects the external horizontal input.
Horiz Vernier control	Potentiometer	Horizontal sweep rate Vernier or external horizontal input gain Vernier. Calibrated position is fully clockwise.
Ext Horiz	BNC connector	Allows external horizontal inputs for oscilloscope.
Trig Level	Stacked concentric potentiometer and switch	Selects oscilloscope trigger level and trigger mode. Center knob selects the level of trigger. Outside (largest) knob controls the trigger mode. In Auto position, continuous sweep with no vertical input signal, syncs on vertical input. Normal position, no sweep unless vertical input is present, syncs on vertical input.
Position controls	Stacked concentric controlled potentiometer	Controls the position of the CRT display, when in the oscilloscope mode.
• Vert	Center (small) control knob	Controls the vertical position of the CRT display
• Horiz	Outside (large) control knob	Controls the horizontal position of the CRT display

4-9

Table 4-1. Controls, Indicators, and Connectors (Cont)

Item	Description	Function
FRONT PANEL (fig. 4-1)		
Vert switch	Four-position rotary switch	Oscilloscope operation uses values marked to the right of the switch, indicating volts per division on the CRT. Values marked to the left of the switch are used during modulation display mode, indicating range for calibrated FM deviation. NOTE: Frequency Counter sensitivity is also controlled by this switch.
Vert Vernier control	Potentiometer	Vernier gain control for vertical inputs to the CRT when in the oscilloscope mode. Fully clockwise is the calibrated position.
Vert:Sinad/DVM/Dist/Counter In Connector	BNC connector	Signal input to the equipment for the following operations: a. External vertical for oscilloscope operation b. Distortion/SINAD Meter c. Frequency Counter d. Digital Voltmeter
RF In/Out connector	Type N connector	RF input in the power monitor or monitor mode, RF output in the generate mode.
RF Level Variable control	Potentiometer	Vernier control of RF output level. Exceeding the AM limit marking in AM generation mode may result in a distorted output.
RF Level Step Switch	14-position ganged atten and switch	Ten dB per step control of RF output level in generate mode. Also serves as RF input level step attenuator in monitor and spectrum analyzer modes.
Ext Wattmeter	Connector	Allows input from Motorola ST-1200 series inline wattmeter elements for measurement and CRT display of forward and reflected transmitted power.
Freq Set controls	Stacked concentric potentiometers	Controls the duplex generator output frequency in the Duplex Generation mode.
	● Coarse	Inside (small) control knob
	● Fine	Outside (large) control knob

4-10

4-5. OPERATION

4-6. The operator may use the CRT display to become familiar with the functions the Communication System Analyzer is capable of performing. The unit may be preset to any of the functions the unit performs. As a function and its parameters are selected they are displayed on the CRT.

The unit contains a nonvolatile memory that stores frequently used data for fast access, reducing setup time. As a function is selected, if data for that function is stored, the data is displayed on the CRT.

One of the stored parameters may be used or the user may manually select (keyboard entry) the parameters required for the function. Selection of stored data or keyboard entry of data is cursor controlled. As a control is changed the CRT display changes to reflect the new parameter being used for function being performed.

4-7. **CALIBRATE.** The Communication System Analyzer may be calibrated to WWV or other time/frequency standards (figure 4-4). To calibrate the unit's time base (frequency standard) proceed as follows:

- Connect antenna to HF In/Out connector.
- Set FUNCTION switch to Monitor and DISPLAY to Gen/Mon Mtr.
- Enter frequency of time/frequency standards station directly from keyboard.
- Select AM function.
- Using a tuning tool, adjust time base frequency calibration control (on left side of housing) until CRT frequency error display indicates less than 5 Hz error. Frequency settable to 0.5 part per million can thus be achieved using a 10 MHz frequency standard station.

NOTE

The time base output is also available on the rear panel for external measurement or laboratory calibration to better than the 0.5 ppm achievable with the above method.

NOTE

An external time base input is also provided on the rear panel.

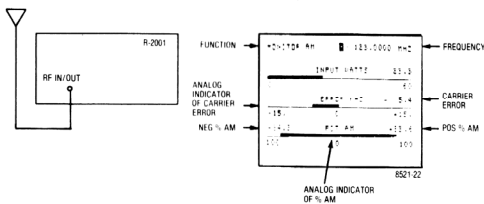

Figure 4-4. System Analyzer Time Base Calibrate Test Setup and CRT Display

4-12

Table 4-1. Controls, Indicators, and Connectors

Item	Description	Function
FRONT PANEL (fig. 4-1)		
Frequency offset control (0-10 MHz/0R/45 MHz)	Three-position switch	Selects the offset of the transmitted frequency from the selected receive frequency (Image/Dplx switch determines side of selected frequency the offset will be). 0-10 MHz position allows frequency offset to be varied between 0-10 MHz. In the 45 MHz position the offset is variable over a small range around 45 MHz with the use of the Fine frequency control.
Output connector	BNC connector	Output connector for duplex generator output.
SIDE PANEL (fig. 4-2)		
Frequency Standard control	Potentiometer	Allows calibration of the time base frequency (freq std)
REAR PANEL (fig. 4-3)		
DC 8A	Line fuseholder (8 amp)	DC input line fuseholder
DC IN power connector	4-pin connector	Connects to DC prime power source
AC power connector	3-pin connector	Connects to AC prime power source. Internally patched to accommodate either 100-110 VAC, 110-130 VAC, 200-220 VAC or 220-260 VAC.
AC 1.5A	Line fuseholder	AC line fuseholder. Use a 1.5A fuse when input voltage is between 100-130 VAC and a 0.75A fuse when input voltage is between 200-260 VAC.
10 MHz std IN connector	BNC connector	Provides for external 10 MHz time base input. Equipment automatically switches to external time base with an input at this connector.
10 MHz std OUT connector	BNC connector	Provides an output of the internal or external 10 MHz time base for external use.
488 BUS connector		Placement of I/O connector when IEEE-488 Interface Bus option is provided.
Blower power connector	4-pin connector	Provides 110 VAC to the cooling fan.

4-11

4-8. **GENERATOR OPERATION.** The system generates RF frequencies for FM, AM, CW, SSB, and DSBSC types of transmission covering a range of 10 kHz to 1000 MHz. To generate a signal the FUNCTION switch is placed in the Gen position.

NOTE

An RF protection circuit to protect against damage due to inadvertent application of RF power to the unit, when in a generate or sensitive monitor mode, is functional over the full monitor frequency range of the equipment (2 to 1000 MHz).

The type of signal is selected using the FUNCTION select LED indicator column. The unit can deliver an output of up to 1 volt into 50 Ohms. When in the AM generate mode the variable control (located in the RF SECTION on the front panel) should not be set above the AM limit mark. Exceeding this may cause distortion in the output.

NOTE

The RF protect circuit may trip if generator is run at full power output without having a 50-ohm load connected.

4-9. **DUPLEX GENERATION.** When operating in the duplex generate mode the offset frequency can be set to either 45 MHz or 0 to 10 MHz (adjustable). The Image/Dplx switch sets the offset frequency above (right) or below (left) the monitored frequency. When offset is in the 0 to 10 MHz range, the control range may include a foldback region. If the generator is operated in this foldback area erroneous frequency output indications can be given. Avoid areas where backward indication or a jittering display of the offset frequency are incurred. The following is an example of the duplex generator being used to setup repeater levels (Figure 4-5).

- Connect DUPLEX GEN output to repeater receiver antenna input and repeater transmitter signal sample to HF In/Out connector. The Duplex Gen Output level is fixed at -30 dB nominal.
- Set FUNCTION switch to Gen and DISPLAY to Duplex Gen.
- Select Duplex Monitor frequency (repeater transmit frequency) from memory table or enter directly from keyboard.
- Set DUPLEX GENERATOR frequency to repeater receiver frequency.
- Adjust PL and test tone deviation to desired level on display.
- Set FUNCTION switch to Monitor and measure the deviation of the repeated signal.

NOTE

Switch function to power monitor and connect repeater transmitter (under 125 watts) directly to the RF In/Out connector to read power and frequency error, as well.

4-13

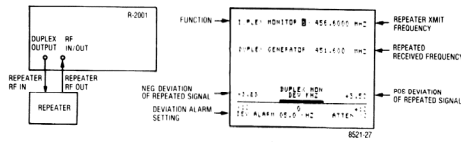

Figure 4-5. Duplex Generation Test Setup and CRT Display

4-10. FREQUENCY COUNTER. The frequency counter measures inputs in a range from 10 Hz to 35 MHz. The input to the frequency counter is through the Vert/Sinad/Dist/DVM/Counter in, BNC connector (located in the OSCILLOSCOPE section of the front panel). The counter sensitivity is controlled by the scope Vert switch. The following shows the minimum sensitivity for each switch setting.

Switch setting	Sensitivity
0.01	50 mV RMS
0.1	500 mV RMS
1.0	5V RMS
10.0	50V RMS

The autorange output of the counter is displayed on the CRT to a resolution of 0.1 Hz or 5 digits.

NOTE

Do not connect transmitter directly to the frequency counter input. Instead use the RF In/Out connector and the frequency error meter for transmitter frequency measurements.

4-11. SPECTRUM ANALYZER. Input to the spectrum analyzer is through the RF In/Out connector. Select the spectrum analyzer position on the DISPLAY column. Place the FUNCTION switch in the monitor position. Select the desired width of sweep by the Disp/Sweep control. The center frequency is selected from the memory or entered directly from the keyboard, it is displayed at the top-right of the CRT. The following is an example of locating the frequency of an incoming signal with the spectrum analyzer (Figure 4-6).

- Connect antenna to RF IN/OUT connector.
- Set FUNCTION switch to Mon. and DISPLAY to Spect. Analyzer.
- Select center frequency from memory table or enter directly from keyboard.
- Adjust Disp/Sweep control for desired spectrum span.
- Adjust Step attenuator if required to reduce sensitivity.
- To determine whether a given displayed signal is valid or being internally generated, flip the Image/Dupl switch to the opposite position. If signal moves in frequency or disappears, it then represents an internally generated spurious response or received image.

NOTE

High-powered equipment in the 1-30 MHz range, which has unusually fast carrier rise times, may damage the system analyzer with repeated activation of the protect circuit. Ensure the FUNCTION switch is in the Pwr Mon position (this enables the protect circuit) before RF power is applied to the equipment.

In the monitor mode the CRT displays the type of signal being monitored, the selected frequency, power, error of the received frequency, and the modulation level.

4-13. EXT WATTMETER. When the analyzer DISPLAY is set to the Ext Wattmeter mode and the Motorola RTL-4055B in-line wattmeter adapter (supplied) is connected to the Ext Wattmeter jack, the analyzer measures both forward and reflected power. The power rating of the wattmeter elements (Motorola ST-1200 series¹), to be used, are displayed on the CRT. The following is an example of a test setup for external wattmeter operation. Figure 4-7 shows the test set connections and CRT display.

- Select the EXT Wattmeter function by means of the arrow keys located below the DISPLAY column.
- Plug the connector of the RTL-4055B In-Line Wattmeter adapter into the "Ext-Wattmeter" jack located on the RF SECTION of the front panel!
- Using the keyboard, enter the single digit which corresponds to the full scale power rating of the ST-1200 series element you plan to use.
- Place the ST-1200 element in the In-Line Wattmeter adapter and install element/adapter assembly into transmission line.

NOTE

Arrow on In-Line Wattmeter Adapter must point in the forward direction of the desired rf power flow through the adapter.

- Key transmitter and observe magnitudes of forward and reflected power as displayed simultaneously on the 2 analog meter bars and corresponding digital readouts.

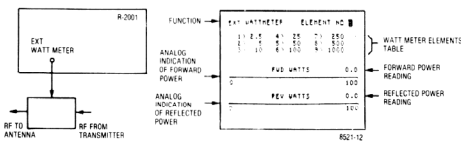

Figure 4-7. Wattmeter Test Setup and CRT Display

¹Contact your Motorola Parts Source for ordering separately

- Use the RF Scan control to move desired signal to center of the screen. If the signal is located to the right of screen center line, move the RF Scan control clockwise into one of five positive stepping modes. If the signal is to the left of screen center line, turn the RF Scan control counter clockwise into one of five negative stepping modes.
- Adjust Disp/Sweep control fully counterclockwise for 1 MHz spectrum span.
- Again use RF Scan to recenter signal on screen.
- Set DISPLAY to Gen/Mon Mtr.
- Now adjust the RF scan control to minimize any existing frequency error between the incoming signal and the Monitor frequency.

- The frequency indicated at the top of the screen is now that of the desired incoming signal. It can also be monitored for call signs, etc.

NOTE

The spectrum analyzer is functional but uncalibrated for level measurements in Power Monitor mode for transmitter testing with the built-in 125 watt 50 ohm load. (Observe "RF LOAD OVERTEMP" warning for high power levels or extended periods of use.)

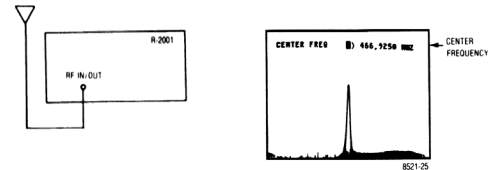

Figure 4-6. Spectrum Test Setup and CRT Display

4-12. MONITOR. The analyzer is capable of monitoring the same frequencies that it generates (para 4-9). Select Gen/Mon Mtr in the DISPLAY column and the modulation type in the FUNCTION column. Set the FUNCTION switch to the Monitor position for small signal samples or off the air monitoring. For high power signal monitoring (0.2w to 125w), set the FUNCTION switch to Pwr Mon.

CAUTION

To prevent undue stress on the protected circuits it is advisable to always switch the system to the power monitor mode before applying power in excess of 200 mw. Additional protection is also obtained by making it a practice not to leave the step attenuator in the 0 dB position.

4-14. SIMULTANEOUS GENERATE AND MEASUREMENT OPERATIONS. The following test setups and CRT displays are examples of simultaneous generating and measurement operations.

- FM Mobile radio setup for receiver sensitivity using Generator and SINAD meter (Figure 4-8).

- Connect RF In/Out mobile radio antenna connector and multipurpose measurement (SINAD) input to receiver audio output.
- Set FUNCTION switch to Gen. and DISPLAY switch to Gen/Mon Mtr.
- Select frequency from RF memory table or enter directly from keyboard.
- Adjust 1 kHz level for 3.0 kHz deviation and RF level for 12 dB SINAD indication. (The mobile radio audio output may be set to the desired level using the DVM AC mode.)
- Read receiver SINAD sensitivity in microvolts or dBm.

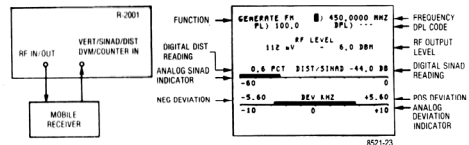

Figure 4-8. Test Setup for FM Receiver Sensitivity Using Generator and SINAD Meter with CRT Display

- Test two-tone pager decode and alert function, and demonstrate simultaneous modulation (Figure 4-9)

- Set FUNCTION switch to Gen and DISPLAY to Gen/Mon Mtr.
- Select pager frequency from RF memory table or enter directly from keyboard.
- Set the DISPLAY to Tone Memory and enter the A/B mode number in the mode select position from the keyboard. For an A/B sequence the mode number is 1. The stored information for the A/B sequence is then automatically displayed on the lower part of the display.
- Enter the number of the desired two-tone sequence in the sequence select position from the keyboard.

NOTE

Timing sequences 1 and 2 are preset and cannot be changed. Sequences 3 and 4 are keyboard programmable for testing other pager types, upper and lower timing limits, or future schemes.

- Enter the pager code Tone A and Tone B Frequencies from the keyboard.
- Set the DISPLAY to Gen/Mon Mtr, the code synthesizer mode to tone A or tone B, and the MODULATION switch to Cont.

- Adjust the Code Synth Lvl control for the desired level of modulation.
- Set the Code Synth Mode to Signal Sequence and the MODULATION switch as desired to activate the pager under test.
- The scope trigger delay setting at the bottom of the Tone Memory Display can be entered as necessary to delay the triggering of the oscilloscope horizontal sweep from the start of the tone sequence. This feature aids in troubleshooting tone decoders with the system oscilloscope.

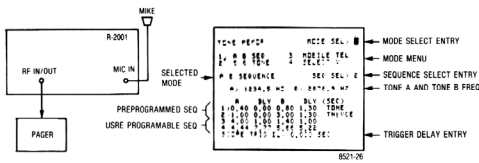

Figure 4-9. Test Setup for Two-Tone Pager and Alert Functions with CRT Display

Test 5/6 Tone Pager decode and alert function (Figure 4-10).

- Set FUNCTION switch to Gen and DISPLAY to Gen/Mon Mtr.
- Select pager frequency from RF memory table or enter directly from the keyboard.
- Set the DISPLAY to Tone Memory and enter the 5/6 tone mode number in the mode select position from the keyboard. For a 5/6 tone sequence the mode number is 2. The stored information for the 5/6 tone sequence is then automatically displayed on the lower part of the display.
- Select either a 5-tone or a 6-tone sequence by entering a 1 or 2 in the sequence select position from the keyboard.
- Enter the desired CAP code from the keyboard.
- Set the DISPLAY to Gen/Mon Mtr, the Code Synth Mode to Tone Seq, and the MODULATION switch to Cont.
- Adjust the Code Synth Lvl control for the desired level of modulation.
- Connect the pager as shown in Figure 4-10 and set the MODULATION switch as desired to activate the pager under test.
- Enter the scope trigger delay setting at the bottom of the Tone Memory display as necessary to delay the triggering of the horizontal sweep relative to the start of the tone sequence when troubleshooting the tone decoder with the oscilloscope.

4-18

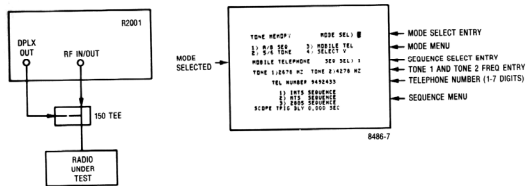

Figure 4-11. Test Setup for Mobile Telephone Test with CRT Display

e. Test Select V decode function (Figure 4-12).

- Set the FUNCTION switch to Gen and the DISPLAY switch to Tone Memory.
- Select the Select V mode by entering the number 4 in the mode select position from the keyboard. The stored information for the mobile telephone sequence will be automatically displayed on the lower part of the display.
- Enter the number of the desired Select V sequence in the sequence select position on the display from the keyboard.
- Enter the desired access number from the keyboard into the access code position on the display.
- Set the DISPLAY to Gen/Mon Mtr, the Code Synth Mode to Tone Seq, and the MODULATION switch to Cont.
- Adjust the Code Synth Lvl control for the desired level of modulation.
- Connect the system to be tested as shown in figure 4-12 and set the MODULATION switch as desired to test the Select V decoder.
- Enter the scope trigger delay setting shown at the bottom of the Tone Memory display as necessary to aid in troubleshooting the decoder circuits.

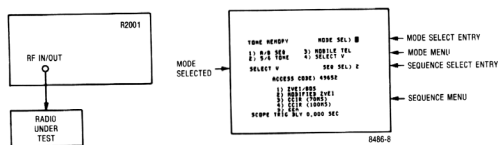

Figure 4-12. Test Setup for Select V Test with CRT Display

4-20

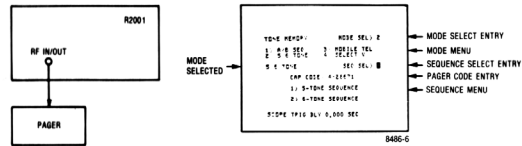

Figure 4-10. Test Setup for 5/6 Tone Pager with CRT Display

d. Test Mobile Telephone Receiver and Supervisory Decoder (Figure 4-11).

- Set the FUNCTION switch to Gen and the DISPLAY to Tone Memory.
- Select the Mobile Telephone mode by entering the number 3 in the mode select position from the keyboard. The stored information for the mobile telephone sequences will be automatically displayed on the lower part of the screen.
- Select the desired mobile telephone sequence by entering the appropriate number in the sequence select position from the keyboard: 1-MTS, 2-MTS, 3-2805.
- With the keyboard enter the appropriate Tone 1 and Tone 2 frequencies on the display.
- Enter the desired telephone number from the keyboard into the Telephone Number position on the display.
- Set the DISPLAY to Duplex Gen and set the DUPLEX GEN switch to the 0-10 MHz or 45 MHz position as applicable. Enter the desired receive frequency from the keyboard and then set the desired transmit frequency using the DUPLEX GEN frequency controls.
- Set the MODULATION switch to the Cont position and adjust the Code Synth Lvl control for the desired level of modulation.
- Set the FUNCTION to Pwr Mon and the DISPLAY to Gen/Mon Mtr.
- Connect the system to be tested as shown in figure 4-11 and set the MODULATION switch as required to test the mobile telephone receiver and supervisory decoder.
- Enter the scope trigger delay setting shown at the bottom of the Tone Memory display as necessary to aid in troubleshooting the decoder circuits.

CAUTION: The entry of a scope trigger delay will prevent normal operation of scope triggering as long as the unit is in the position "MODULATION", "Tone Seq."

4-19

f. Troubleshooting Receiver audio stages using "DVM and Signal Generate" function simultaneously (Figure 4-13).

- Select the DVM function by means of the arrow keys located below the DISPLAY column.
- Using the keyboard's "down" arrow position the CH1 cursor adjacent to the "DVM Mode" graphics.
- Enter a "1" via the keyboard to select AC voltage measurement or a "2" for DC voltage measurement selection.
- Set up the desired on-channel RF signal to provide an input to the receiver.
- Set FUNCTION switch to "Gen"; Set appropriate RF output level (as indicated on the CRT screen)
- Apply test signals from the receiver audio stages to the instrument's "Vert.Sinad;Dist.DVM Counter In" input. DC Voltage measurement points are also applied to this same input. The supplied X1 test probe may be used.
- Refer to the CRT screen for an auto-ranging and analog/digital indication of either DC voltage or AC voltage and corresponding dBm level.

NOTE

The AC DVM indication of dBm is referred to 600 ohms.

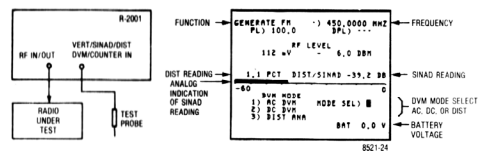

Figure 4-13. Test Setup for Using DVM and Signal Generate with CRT Display

4-21



MOTOROLA, INC.
COMMUNICATIONS SECTOR
TEST EQUIPMENT REPAIR CENTER
1313 EAST ALGONQUIN ROAD SCHAUMBURG, ILLINOIS 60196

TEST EQUIPMENT REPAIR REQUEST FORM

This completed form must accompany equipment returned for repair.

CUSTOMER'S PURCHASE ORDER NO.		DATE	
MODEL NUMBER		SERIAL NUMBER	
DESCRIPTION OF PROBLEM:			
REQUESTED REPAIRS:			
SHIP TO ADDRESS:			
SHIP VIA:			

Providing the information below will reduce the turnaround time on your Test Equipment Repair.

MOTOROLA CUSTOMER NUMBER	BILL TAG	SHIP TAG	INTERNAL MOTOROLA ACCOUNT NO.

SIGNED: _____

SECTION V MAINTENANCE

5-1. SERVICE

5-2. The Motorola Test Equipment Repair Center is charged with the service responsibility for all test equipment supplied by the Motorola Communications Group. The center maintains a stock of original equipment replacement parts and a complete library of service information for all Motorola test equipment.

5-3. Most in-warranty repairs are performed at the center. Exceptions include repairs on some equipment not manufactured by Motorola which are performed by the original supplier under the direction of the Test Equipment Repair Center. Out-of-warranty service is performed on a time and materials basis at competitive rates and the maximum turn-around goal is less than ten working days. Customer satisfaction is continually surveyed by reply cards returned with repaired instruments.

5-4. The Test Equipment Repair Center also provides a convenient telephone troubleshooting service. Frequently, a user technician can troubleshoot a piece of equipment and isolate defective components under the direction of the Test Equipment Repair Center via telephone. Required replacement parts are then immediately shipped to the user thereby reducing shipping time and servicing costs. For telephone troubleshooting contact the Test Equipment Repair Center toll free at (800) 323-6967.

5-5. All other inquiries and requests for test equipment calibration and repairs should be directed to the Area Parts Office. They will contact the Test Equipment Repair Center, process the necessary paperwork and, if necessary, have the Center contact you to expedite the repair.

5-6. REPLACEMENT PARTS ORDERING

5-7. Motorola maintains a number of parts offices strategically located throughout the United States. These facilities are staffed to process parts orders, identify part numbers, and otherwise assist in the maintenance and repair of Motorola Communications products.

5-8. Orders for all replacement parts should be sent to the nearest area parts and service center listed below. When ordering replacement parts the complete identification number located on the equipment should be included.

5-9. ADDRESSES

5-10. General Offices

MOTOROLA INC.
Communications Division Parts Dept.
1313 E. Algonquin Rd.,
Schaumburg, Illinois 60196
Phone: 312-397-1000
Executive Offices: 1301 E. Algonquin Rd.,
Schaumburg, Illinois 60196

5-11. U.S. Orders

WESTERN AREA PARTS

1170 Chess Drive, Foster City,
San Mateo, California 94404
Phone: 415-349-3111
TWX: 910-375-3877

MID-ATLANTIC AREA PARTS

7230 Parkway Drive
Hanover, Maryland 21076
Phone: 301-796-8600
TWX: 710-862-1941

EASTERN AREA PARTS

85 Harristown Road
Glen Rock, New Jersey 07452
Phone: 201-447-4000
TWX: 710-988-5602

SOUTHWESTERN AREA PARTS

3320 Belt Line Road
Dallas, Texas 75234
Phone: 214-241-2151
TWX: 910-860-5505

GULF STATES AREA PARTS

8550 Katy Freeway
Houston, Texas 77024
Phone: 713-932-8955

MIDWEST AREA PARTS

1313 E. Algonquin Rd.
Schaumburg, Ill. 60196
Phone: 312-576-7322
TWX: 910-693-0869

EAST CENTRAL AREA PARTS

12995 Snow Road
Parma, Ohio 44130
Phone: 216-267-2210
TWX: 810-421-8845

PACIFIC SOUTHWESTERN AREA PARTS

9980 Carroll Canyon Road
San Diego, California 92131
Phone: 714-578-2222
TWX: 910-335-1634

SOUTHEASTERN AREA PARTS

5096 Panola
Industrial Blvd.,
Decatur, Georgia 30032
Phone: 504-981-9800
TWX: 810-766-0876

5-12. Canadian Orders

CANADIAN MOTOROLA ELECTRONICS COMPANY

Parts Department
3125 Steeles Avenue
East Willowdale, Ontario
Phone: 516-499-1441
TWX: 610-492-2713
Telex: 02-29944LD

5-13. All Countries Except U.S. and Canada

MOTOROLA INC., OR MOTOROLA AMERICAS, INC.

International Parts
1313 E. Algonquin Road,
Schaumburg, Illinois 60196 U.S.A.
Phone: 312-397-1000
TWX: 910-693-1592 or 1599
Telex: 722433 or 722424
Cable: MOTOL

CAUTION

This equipment contains parts that are subject to damage by static electricity. Proper precautions should be taken during handling.

WARNING

Lithium Battery

The processor module within this system utilizes a lithium battery as a memory keep-alive voltage source. Do not mutilate or disassemble the battery cell. The lithium metal is a very active material that burns in the presence of water or high humidity. Do not put the battery in fire, attempt to charge, heat above 100°C, or solder directly to the cell. Do not overdischarge the cell to a reverse voltage greater than 3 volts. The battery may burst and burn or release hazardous materials. See paragraph 5-143 of this manual for battery troubleshooting procedures and cautions.

CAUTION

Lithium Battery

Lithium batteries are classified as hazardous materials and must be disposed of accordingly. Do not dispose of the battery by placing it in with the everyday trash. Consult state and local codes for the appropriate disposal procedure. Motorola will dispose of the battery if the expended battery is returned in the replacement battery container and by the same method that the new battery came to you to: Motorola Inc., Return Goods Department, 1313 East Algonquin Road, Schaumburg, Ill. 60196.

5-14. MAJOR ASSEMBLIES

5-15. The Communication System Analyzer is designed for ease of maintenance. Most of the circuitry is on twelve plug-in circuit boards. A list of all subassemblies is given in table 5-1. The assembly locations are shown in figures 5-1 and 5-2.

Table 5-1. List of Subassemblies

Ref. Des.	Item	Part Number As Labeled	Replacement Order Part No.
A1	Low Voltage Power Supply Module	01-P07897V001	RTP-1005A
A1A1	Low Voltage Power Supply Switcher Module	01-P07891V001	RTP-4016A
A1A2	Low Voltage Power Supply Output Module	01-P07856V001	RTP-4013A
A1A3	Low Voltage Power Supply Control Module	01-P07853V001	RTP-4012A
A1A4	Lower Voltage Power Supply Relay Module	01-P07892V001	01-80305A68
A2	Scope Amplifier Module	01-P00413N002	RTC-4007B
A3	Scope/DVM Control Module	01-P24154A001	RTC-4024A
A4	Receiver Module	01-P00389N002	RTL-1002B
A5	Synthesizer Module	01-P00385N002	RTC-1001B
A5A*	Digital Synthesizer Card	01-P00358N002	RTC-4009B
A5B*	RF Synthesizer Card	01-P00386N002	RTC-4010B
A6	Audio Synthesizer Module	01-P00426N002	RTC-4011B

Table 5-1. List of Subassemblies (Cont)

Ref. Des.	Item	Part Number As Labeled	Replacement Order Part No.
A7	Processor Input/Output Module	01-P24158A001	RTC-4025A
A8	IEEE Bus Module (Optional)	01-P00203N002	RTC-4013B
A9	Microprocessor/Character Generator Module	01-P24162A001	RTC-4026A
A10	High Voltage Power Supply Module	01-P07896V001	RTP-1006A
A11	RF Input Module	01-P00394N003	RTC-1002B
A11A1*	Protection/Power Meter Card	01-P00400N002	RTL-4061B
A11A2*	Converter/Wide Band Amplifier Card	01-P00399N002	RTC-4015B
A11A3*	Offset Generator Card	01-P00399N002	RTC-4016B
A12	Front Panel Interface Module	01-P07846V001	RTL-4086A
A13	Frequency Standard Module	01-P07896V001	RTL-1011A
A14	Front Panel Assembly	01-P07860V001	01-80305A64
A14A1	Display Board Assembly	01-P07843V001	1-80305A63
	Motherboard Assembly	01-P07894V001	RTL-4089A

*These items are solder-in submodules listed for reference purposes. These cards are not normally repaired or replaced individually.

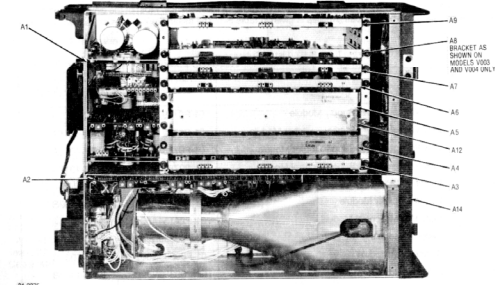

Figure 5-1. Communications System Analyzer, Top View, Cover Removed

5-4

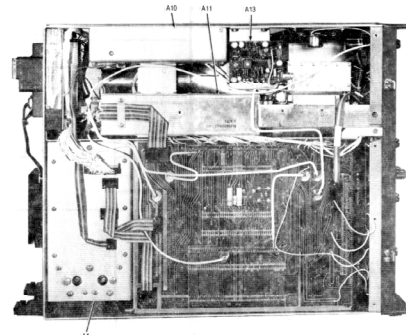

Figure 5-2. Communications System Analyzer, Bottom View, Cover Removed

5-16. THEORY OF OPERATION

5-17. General

5-18. The operation of the Communications System Analyzer can be divided into nine basic functions: Generate, Power Meter, Monitor, Duplex Generator, Code Synthesizer, Frequency Counter, Digital Voltmeter (DVM), Oscilloscope, and Distortion/SINAD Meter. The general operation of the unit will simultaneously incorporate the basic functions to provide the total capability of the system.

5-19. The following discussion will cover the block diagrams for each of the basic functions plus a discussion on the processor control of the system. A functional block diagram of the total system is shown in figure 5-3. Only the major signal paths between each of the modules are shown to clarify the total system configuration.

5-5

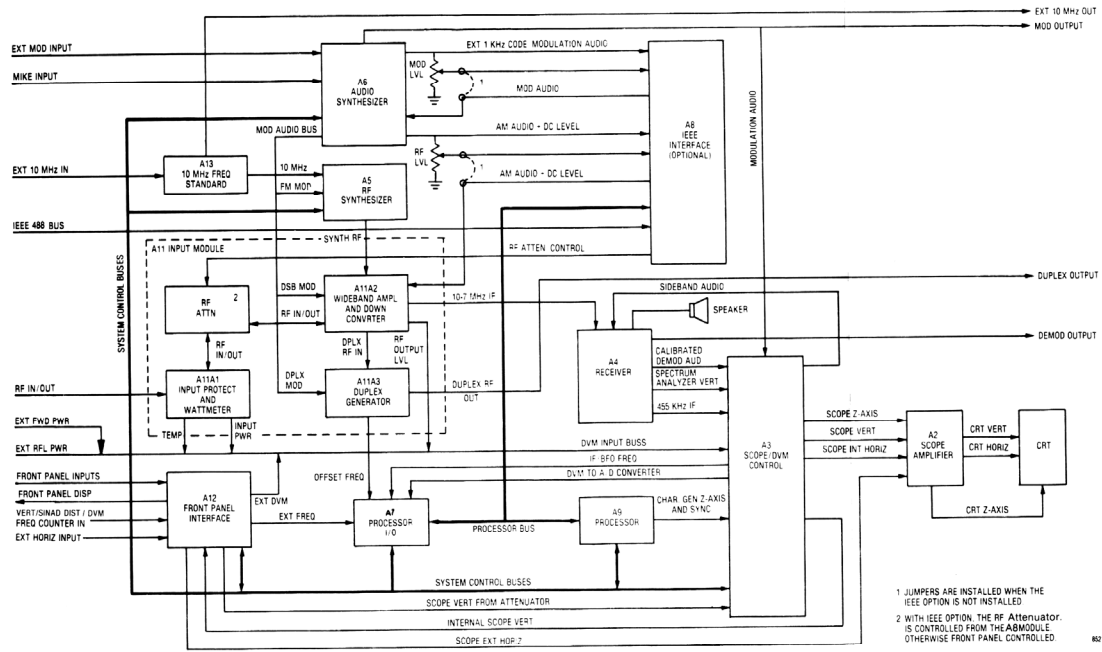

Figure 5-3. Communication System Analyzer, Block Diagram

1 JUMPERS ARE INSTALLED WHEN THE IEEE OPTION IS NOT INSTALLED.
2 WITH IEEE OPTION, THE RF ATTENUATOR IS CONTROLLED FROM THE ABMODULE OTHERWISE FRONT PANEL CONTROLLED.

5-7

5-20. System Control

5-21. System Control is the primary responsibility of the internal microprocessor. Front panel control and system status inputs to the processor are manipulated by the processor to provide the control for the operating mode. From the front panel the processor monitors the keyboards, the function select switch, the modulation control switch, the RF scan switch, the image switch, the bandwidth switch, the horizontal and vertical range switches, and the step attenuator switch. This information plus internal status information causes the processor to display the appropriate information on the CRT to program the center frequency, to set up the generate or monitor mode, and to make the internal switching arrangements for the selected operating state.

5-22. The interface to and from the microprocessor is via the processor bus. This bus consists of a 16-bit address bus, an 8-bit data bus, and a 7-bit control bus. This bus interfaces the processor to its program memory (ROM), scratch pad memory (RAM), IEEE interface, and the peripheral interface adapters (PIA). The PIA is the mechanism by which the processor interfaces with the system. A PIA consists of a dual 8-bit latch which may be programmed as either an input or output for the microprocessor. System input and control information passes to and from the microprocessor via three system control buses attached to a PIA.

5-23. Each system control bus consists of a 4 bit address bus, a 4 bit data bus, and an enable line. The 4 address bits determine which of 16 possible latches the 4 bits of data is to be sent to or received from. The enable line triggers the actual transfer of data. The three control buses within the system are called the RF control bus and the AF control buses 1 and 2. The RF control bus is as described above while the AF control buses consist of a single 4-bit address and 4-bit data bus and two enable lines. The resulting total input/output capability for the system buses is 16 latches at 4-bits each times 3 buses or 192 bits. A tabulation of buses and the controlling or input function of each bit is shown in table 5-2.

5-24. Systems with the IEEE remote control option interface the IEEE bus to the processor bus through a general purpose interface bus adapter (GPIB) on the IEEE interface module. When enabled all control inputs to the system pass through the IEEE bus and front panel controls are ignored. For more information on IEEE control see section 21.

5-25. Generate Mode

5-26. The generate mode provides a variable level RF output that is phase locked to the internal 10 MHz standard. AM, FM, and Sideband Modulation are possible on the output signal. A block diagram of the generate mode is shown in figure 5-4.

5-27. The Frequency Standard module (A13) contains a 10 MHz standard oscillator with buffering and switching to provide a 10 MHz signal to the EXTERNAL 10 MHz OUTPUT and to the RF Synthesizer (A5). A provision is made for the application of an EXTERNAL 10 MHz INPUT which causes the internal standard to shut down and the EXTERNAL 10 MHz INPUT to be switched to the EXTERNAL 10 MHz OUT and to the RF Synthesizer.

5-28. The 10 MHz standard input to the RF synthesizer is digitally divided down to provide SYSTEM REFF FREQUENCIES for the frequency counter, the zero beat detector, the second local oscillator in the receiver, and the processor timing reference. Additionally reference frequencies are provided for a fixed 550 MHz locked loop and for a programmable 500 MHz-1000 MHz locked loop. The programming of the 500 MHz-1000 MHz locked loop is provided by the RF CONTROL BUS from the processor. The SELECT SWITCH selects one of three possible output points for the SYNTH RF output signal. The first is from the 500 MHz-1000 MHz loop directly. The second is from a divide by two on the output of the 500 MHz-1000 MHz loop which gives frequencies from 250 MHz to 500 MHz. For outputs below 250 MHz, the output of the 500 MHz- 1000 MHz loop is mixed with the fixed 550 MHz signal and the difference signal used for the output. For this output the processor programs the 500 MHz - 1000 MHz loop for frequencies between 550.01 MHz and 800 MHz to obtain outputs from 10 kHz to 250 MHz respectively.

5-29. FM and SWEEP Modulation is implemented within the 500 MHz-1000 MHz loop. FM capability is 200 kHz peak which when divided by two gives the 100 kHz peak requirement. Similarly the sweep capability is 10 MHz peak which provides the 5 MHz requirement for the sweep generator and spectrum analyzer requirements.

Table 5-2. Control Buses and Functions

Data	RF Bus				AF Bus #1				AF Bus #2				Data		
	D3	D2	D1	D0	D3	D2	D1	D0	D3	D2	D1	D0			
ADRS													ADRS		
0	310-440 PLL	A0			Audio Synth				N0				Display Led's	0	
1	310-440 PLL	N0			Audio Synth				N1				Function Led's	1	
2	310-440 PLL	N1			Audio Synth				N2				Mode Led's	2	
3	60 PLL	N0			Audio Synth				N3				Input Scope Atten	3	
4	60 PLL	N1			PL Sel	DPL CLK Enab	DPL Sel	AUDIO Synth N4					Attn Int/Ext Sel	Ext In AC/DC Sel	4
5	60 PLL	N2			MOD To Spk/Enab	Audio Atten 30 dB	Audio Atten 20 dB	Audio Atten 10 dB					RF Atten Position	5	
6	60 PLL	N3			DPLX MOD Enab	DSBSC MOD Enab	FM MOD Enab	AM MOD Enab					Scan Switch Position	6	
7	310-440 PLL	A1	60 PLL	N4					IF Overd In	SIG Present In	RF Input < 20 dB In	WB/NB Sw In	7		
8					DVM MODE Select				SSSC CPT In	CSIG BURST Sw In	H/LO Image Sw In	Gen Sw In	8		
9	WB MOD Enab	(MOD) x (2) Enab	MOD INV/INV Sel	MOD FM SWP Enab	Scope Trig Enable	Ph Det FM MOD Enab	Ph Det AM MOD Enab	Ph Det Demod Enab	DSBSC CPT In	CSIG BURST Sw In	H/LO Image Sw In	Gen Sw In	9		
A	0.01-1000 VCO Sel	500-700 INV/INV Sel	LOOP INV/INV Sel	MOD Disable	Distort Notch Filter x1 x10 Gain	Int DVM x 0.1	WB/NB Sel	IF/BFO Freq Sel	Mon Sw In	Scope Switch Sw In	Scope Pos Sw In		A		
B					Horiz Scope Mode Sel				Vert Scope Mode Sel				B		
C					Scope Time Base CTL								C		
D	SSB Demod Enab	FM Demod Enab	AM Demod Enab	Demod To Spk/Enab	SSC3	SSC2	SSC1	SSC0					D		
E	WB/NB Sel	Demod INV/INV Sel	Alarm Enab	LN IN Log IF Sel	SSC7	SSC6	SSC5	SSC4	DVM RMS/DIP Sel	Freq Cntr Range			E		
F					Ctr/DVM Sel				Counter Input Sel	IF/BFO Offset	Ext		F		

5-10

action protects the Wideband Amp and Step Attenuator against burnout. A signal line from the protection network signals the processor that the system is in the protected mode. The processor in turn activates the CRT and alarm warnings.

5-34. Power Meter

5-35. Input power measurements are made with the RF input terminated into an internal 50 ohm load. This termination is the same one used for the protect mode when in the generator or monitor functions. A block diagram of the power meter is shown in figure 5-5.

5-36. For the power meter mode the processor sets the WATT METER ENABLE line to cause the RF input jack to be switched to the 50 ohm power termination. For modes other than the power meter, an input detector on the RF input jack detects when the input power has exceeded 200 mW and then switches the input to the load.

5-37. The switch is a single pole double throw configuration so that when switched to the RF load the path to the Step Attenuator and Converter is open circuited. However, leakage across the open switch provides sufficient signal for operation of the normal monitor functions.

5-38. A sample of the RF voltage being applied to the RF Load is detected by the Power Detector to give a DC output proportional to the peak RF voltage. The amplifier following the detector buffers and gain adjusts the detected voltage to provide the RF INPUT POWER signal to the processor. The processor then determines and displays the RF input power.

5-39. A Temperature Sensor located near the flange of the RF Load alerts the processor when the load temperature exceeds 80 °C. The processor reacts to the OVER TEMPERATURE signal by displaying a warning message on the CRT and by sounding the audible alarm.

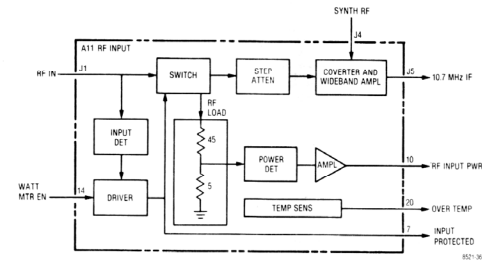

Figure 5-5. Power Meter Block Diagram

5-12

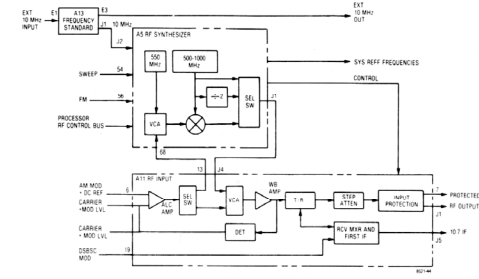

Figure 5-4. Generate Mode Block Diagram

5-30. The SYNTH RF signal is amplified and leveled in the RF input module (A11). The signal level at the output of the wideband amp is detected and compared to the AM MOD & DC REF signal from the front panel level control. If there is a difference between the two signal levels, the ALC amp provides an error voltage. The error voltage controls the attenuation of the Voltage Controlled Attenuator (VCA) in the direction that will make the detected RF output equal to the AM MOD & DC REF signal. There are two possible VCAs for the output leveling. The VCA within A11 is used for frequencies from 1 MHz to 1000 MHz. For frequencies below 1 MHz, the VCA on A11 is set to minimum attenuation and the VCA on the RF Synthesizer module is used for leveling. Amplitude modulation is incorporated by summing the modulation signal with the DC reference signal to force the leveling loop to vary the output level in proportion to the modulating signal. The signal from the RF level detector (CARRIER + MOD LVL) is used by the processor for the determination of RF output level and the percent AM. The leveled output range of the Wideband Amp is from -3 dBm to +13 dBm (0.16 to 1.0 Vrms).

5-31. The leveled output from the Wideband Amplifier is applied to the Generate Monitor (T/R) switch. For AM, FM, and CW signals the switch connects the amplifier output to the Step Attenuator. For Double Sideband Suppressed Carrier (DSBSC) the T/R switch is in the "R" position where the amplifier output is connected to the local oscillator port on the receive mixer and the attenuator is connected to the RF port. The DSBSC MOD signal is then used to drive the IF port of the mixer giving a DSBSC signal at the RF port and thus at the Step Attenuator.

5-32. Coarse level control in 10 dB increments is provided by the Step Attenuator. The total range of the attenuator is from 0 dB to 130 dB attenuation. For the basic R2001C the Step Attenuator is electrically programmable and controlled by the processor. The front panel knob in this case is connected only to a rotary switch which directs the processor in setting the attenuation level. Under IEEE control, commands via the IEEE bus determine the attenuator setting. (See section 2.1.)

5-33. The RF signal from the Step Attenuator passes through the input protection circuitry to the HF Output Jack. A level detector on the RF Output jack monitors the power level at the jack. If power in excess of 200 mW is applied to the Output Jack, the protection circuit will activate and switch the RF Output jack to the internal 50 ohm load. This

5-11

5-40. Monitor Mode

5-41. The monitor mode allows RF signals from an antenna or from a transmitter directly to be checked for frequency error, modulation level, and spectral content. AM, FM, and sideband modulations can be accommodated with this system. A block diagram of the monitor mode is shown in figure 5-6.

5-42. The RF signal to be monitored is applied to the RF Input Jack on the RF Input module (A11). If the input level is less than 200 mW the input signal passes directly through the Input Protection circuitry to the Step Attenuator. For input levels greater than 200 mW the protection circuit switches the input to the internal load and signal the operator to switch to the Power Monitor mode. In this case, RF leakage (paragraph 5-37) through the protection circuits provides the input signal to the Step Attenuator.

5-43. For the monitor mode the T/R switch is set so that the RF input from the Step Attenuator is connected to the RF port on the receive mixer. The output from the wideband amp is switched to the local oscillator port on the receive mixer. The processor programs the RF Synthesizer for an output frequency that is offset from the frequency to be monitored by 10.7 MHz. The offset may be above or below the center frequency as selected by the front panel image switch.

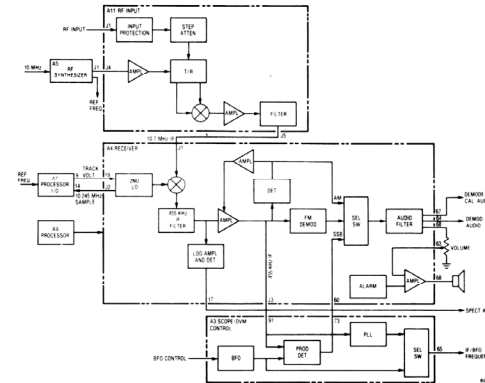

Figure 5-6. Monitor Mode Block Diagram

5-13

5-44. The 10.7 MHz difference signal at the IF port of the receive mixer is amplified and selected by the first IF Amplifier and Filter. The Amplifier provides sufficient gain so that the overall gain of the RF input module is 10 ± 2 dB. The IF filter provides a modulation acceptance bandwidth of ≈ 100 kHz. The filter output is the 10.7 MHz IF signal to the Receiver module (A4).

5-45. A second mixer in the receiver module down converts the 10.7 MHz IF signal to 455 kHz by mixing the input signal with a 10.245 MHz Second Local Oscillator. The Second Local Oscillator is phase locked to the 10 MHz system standard so that its frequency is as accurate as the standard. The phase locked loop for the Second Local Oscillator is split between two modules. A 10.245 MHz SAMPLE signal is compared with the REFERENCE FREQUENCIES from the RF Synthesizer on the Processor I/O module (A7). The comparison provides a TRACKING VOLTAGE error signal to the 10.245 MHz oscillator which corrects its frequency to hold it in lock.

5-46. Immediately following the second mixer is the IF filter. The IF filter is selectable between a narrowband (± 6 kHz mod acceptance) and a wideband (± 100 kHz mod acceptance) bandwidth. The bandwidth is under the control of the processor and is selected by the bandwidth switch on the front panel.

5-47. The output signal from the IF filter has two possible paths. The path to the Log Amplifier and Detector provides the spectrum analyzer capability. The other path is the linear IF Amplifier for AM, FM, and SSB demodulation. The output level of the Amplifier is detected to give amplitude modulation and to provide the AGC control on the IF amplifier. The IF signal is applied to the FM Demodulator and is sent to the Scope/DVM Control module (A3) for SSB demodulation and for frequency error determination.

5-48. Demodulated audio from the selected demodulator is routed to the Audio Filter by the Select Switch under processor control. The Audio Filter provides post detection filtering for both wide and narrow band modes. The output of the Audio Filter is three signal lines. The Demod Calibration Audio line provides the calibrated audio levels for modulation level determination. A Demod Audio output provides a level adjusted signal to the front panel Demod Out jack. Speaker audio is level adjusted by the front panel volume control and then amplified by the Audio Amplifier on the Receiver module.

5-49. The Audio Amplifier sums the audio from the demodulator with the Alarm audio. The Audio Amplifier provides a 0.5 watt output capability to the system's internal speaker. The Alarm generator is under the control of the system processor.

5-50. SSB demodulation is implemented on the Scope/DVM Control module by multiplying the 455 kHz IF signal from the Receiver with a signal from the Beat Frequency Oscillator (BFO). The BFO is controlled from the front panel and typically has a frequency range of 455 ± 3 kHz. The BFO signal is switched with the output of the 455 kHz IF Phased Locked Loop (PLL) to the frequency counter for frequency error determination. The 455 kHz PLL filters and shapes the IF signal to make it suitable for frequency counting.

5-51. When in the spectrum analyzer mode the linear IF Amplifier is shut down and the Log Amplifier is activated. The output of the Log Amplifier and Detector is a DC voltage that is proportional to the log of the 10.7 MHz IF input level. The log circuit has a dynamic range of approximately 80 dB, covering input levels from -110 dBm to -30 dBm. The SPECTRUM ANALYZER signal from the Log Amplifier is the vertical input to the scope for the spectrum analyzer display.

5-52 Duplex Generator

5-53. Simultaneous generate and monitor functions are available with the use of the Duplex Generator. The frequency spread between generate and monitor frequencies is limited to a range of 0 to 10 MHz and a fixed frequency of 45 MHz. A block diagram of the Duplex Generator function is shown in figure 5-7.

5-54. The Duplex Output signal is generated by mixing the local oscillator signal for the first receive mixer with a signal from the Offset Oscillator. The Offset Oscillator is at the frequency equal to the desired spread between generate and monitor frequencies less the 10.7 MHz IF offset. The monitor function is unaffected by the duplex mode and operates as described under paragraph 5-40.

5-14

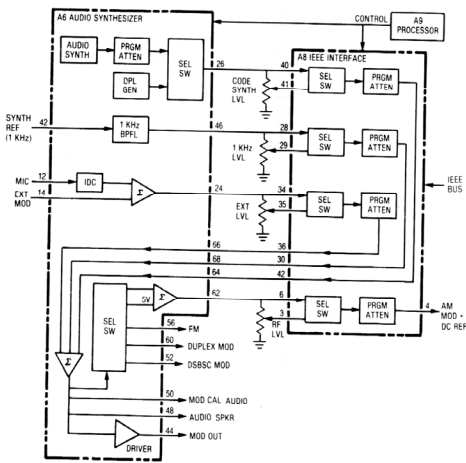

Figure 5-8. Code Synthesizer Block Diagram

5-62. Systems without the IEEE option will have the wipers of the level control pots jumpered to their respective inputs to the summation amps on the Audio Synthesizer module (A6). Those systems with the IEEE option will select on the IEEE interface module (A8) either the tops of the level control pots or their wipers to the Programmable Attenuators for remote or local control respectively. While in the IEEE Control mode the processor controlled Programmable Attenuator on the IEEE module provides the modulation level control. For the local mode the attenuators are programmed for zero attenuation so that the wipers of the level control set the modulation levels directly.

5-63. The three modulation sources are summed together on the Audio Synthesizer module after the level controls. The composite modulation signal is then switched to the appropriate modulator and applied to the modulation determination circuitry (MOD CAL AUDIO), the audio amplifier (SPKR AUDIO), and the Modulation Output jack (MOD OUT) on the front panel. The signal to the front panel jack is buffered by a Driver Amplifier to provide a low driving source impedance.

5-16

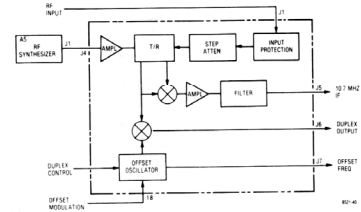

Figure 5-7. Duplex Generator Block Diagram

5-55. Frequency modulation of the duplex output is obtained by modulating the Offset Oscillator frequency via the OFFSET MOD signal line. Control of the Offset Oscillator is directly from the front panel of the system. An OFFSET FREQUENCY output from the oscillator provides an input to the frequency counter for the determination of the duplex frequency.

5-56. Code Synthesizer

5-57. Three simultaneous modulation sources are possible with the internal Code Synthesizer. A private line (PL) or Digital Private Line (DPL) source, a fixed 1 kHz source, and external modulation sources are individually level controllable and summed together to give the composite modulation audio. The Code Synthesizer provides the modulation source for the system in the generate mode and can be used as an audio frequency source when in the monitor mode. For the IEEE option a provision is made to allow processor control of the modulation levels. A block diagram of the Code synthesizer is shown in figure 5-8.

5-58. The PL signaling sequence generator is an Audio Synthesizer with an output frequency range from 5 Hz to 10 kHz in 0.1 Hz steps. The frequency is programmed by the processor in response to the operator's request from the keyboard through the CRT display. The Programmable Attenuator following the synthesizer provides 10 dB and 30 dB attenuation levels for the tone remote access sequence.

5-59. DPL Code words are generated by the processor in response to the code entered by the operator. The 23-bit DPL word is stored in the DPL Generator and continuously output when selected. Either PL or DPL signals are switched to the Code Synthesizer Level control on the front panel.

5-60. A 1 kHz reference signal from the RF Synthesizer is bandpass filtered to provide a low distortion 1 kHz sine-wave to the front panel 1 kHz Level Control.

5-61. Two sources of external modulation are possible. A standard Motorola microphone interface jack on the front panel and a BNC front panel jack are provided. The microphone input is connected to an IDC circuit for peak limiting. The composite of the two external modulation sources is the signal to the External Level control on the front panel.

5-15

5-64. The AM modulation signal at the output of the Select Switch is summed with a +5 volt signal. This combination provides a DC level to control the average output power of the wideband amp in the RF input module, and a superimposed modulation signal to give AM. The RF Level control on the front panel for local control or the Programmable Attenuator on the IEEE module provide local or remote RF level control by simultaneously attenuating the DC level and the modulating signal. The resulting signal is the AM MOD + DC REFERENCE signal to the RF Input module.

5-65. Frequency Counter

5-66. Three possible signal sources are made available to the frequency counter for frequency determination. Two of the inputs are from internal system points for the determinations of the offset frequency (OFFSET), and the monitored carrier error frequency (IF/BFO). The third input is the external input (FREQ CNTR INPUT) on the front panel. A block diagram of the frequency counter function is shown in figure 5-9.

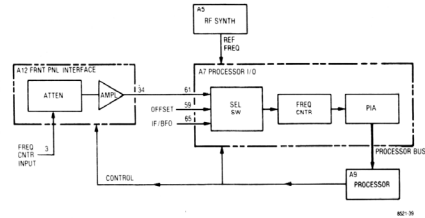

Figure 5-9. Frequency Counter Block Diagram

5-67. The external input signal is routed to the Front Panel Interface module (A12). A range Attenuator on the Interface module provides variable sensitivity settings according to the vertical range switch setting on the front panel. An Amplifier following the range Attenuator amplifies and limits the signal amplitude for the frequency counter input.

5-68. A Select Switch on the Processor I/O module (A7) routes the desired signal to the Frequency Counter circuitry. The signal selected is controlled by the processor and is determined by the operating mode of the system.

5-69. A 16-bit gate accumulator is used to determine the input frequency. Gate times from 1 msec to 10 sec are automatically selected by the processor to give the maximum possible resolution. The gate times are derived from the RF Synthesizer REFERENCE FREQUENCIES and thus are as accurate as the system time base.

5-70. The 16-bit Frequency Counter output is transferred directly to the processor bus through a Peripheral Interface Adapter (PIA). The processor in turn adjusts the data for the gate time used and then processes the information to obtain the required frequency display.

5-17

5-71. Digital Voltmeter (DVM)

5-72. The processor through the DVM circuitry has access to voltage information at a large number of points throughout the system. From this information the processor is able to determine and display parameters such as: output power level, modulation level, input power level and the like. In addition, an external voltage applied to the DVM input jack on the front panel can be measured and displayed for external voltage measurements. A block diagram of the DVM function is shown in figure 5-10.

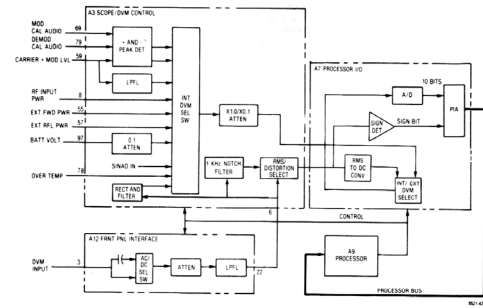

Figure 5-10. Block Diagram DVM/Distortion Analyzer

5-73. Internal voltage measurements are selected and ranged over two decades by the INT DVM SELECT SWITCH and the X1/DX10.1 attenuator respectively on the Scope/DVM Control (A3) module. The resulting 0 to 1 VDC signal is routed to the INT/EXT DVM SELECT SWITCH on the Processor Interface (A7) module which applies the voltage to the A/D converter. The A/D converter converts the input voltage into a 10 bit digital word which is input to the processor. One of eight internal voltages may be selected for measurement as required by the processor to determine display data. Inputs to the A/D must be less than 1 VDC; therefore, with the decade X1/X.1 ranging attenuator the maximum input voltage to the internal DVM is 10 VDC. The X1 position of the attenuator is switched in for better voltage reading resolution on voltages less than 1 VDC. To keep CRT information current, each of the required measurements are made in sequence at an approximate rate of thirty per second.

5-74. Two modulation signals (MOD CAL AUDIO and CARRIER + MOD LVL) and a demodulated signal (DEMOCAL AUDIO) are made available to the peak detectors. Positive and negative peak determination of the selected signal enables the processor to determine the level of modulation.

5-75. A Lowpass Filter (LPFL) removes the DC component from the CARRIER + MOD LVL signal so that the generated RF output level can be determined. Refer to paragraph 5-30.

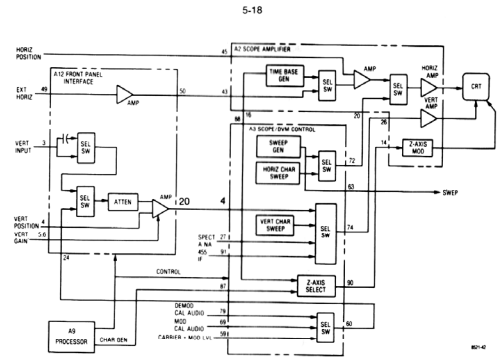

Figure 5-11. Oscilloscope Block Diagram

5-88. Six decade sweep ranges from 1 μ sec to 100 msec per division are provided by the Time Base Generator. Control of the Time Base Generator is from the front panel horizontal switch through the processor.

5-89. Front panel external horizontal inputs are applied to the top of the horizontal vernier gain potentiometer. The wiper of the gain potentiometer is the EXTERNAL HORIZONTAL input signal to the preamp on the Front Panel Interface module (A12). The preamp provides the required horizontal input sensitivity and buffers the signal to the select switch on the Scope Amplifier module.

5-90. Internal horizontal signals, Sweep Generator and Character Sweep outputs, are selected on the Scope/DVM Control module (A3). The Sweep Generator provides a sawtooth waveform to the RF Synthesizer module for the sweep generator and spectrum analyzer functions. The sweep signal to the CRT horizontal input causes the scope sweep to be synchronous with the synthesizer sweep for the spectrum and sweep filter response displays.

5-91. The Horizontal Character Sweep generator output is a sawtooth waveform that provides the horizontal sweep for the raster scan character display.

5-92. One of four possible vertical signal sources are switched to the Vertical Amplifier input by a Select Switch on the Scope/DVM Control module. The 455 kHz IF and SPECTRUM ANALYZER signals from the Receiver Module provide the IF envelope and spectrum analyzer displays respectively. The Vertical Character Sweep generator gives the vertical sweep for the raster scan character display. The remaining input is the path for external vertical or modulation scope vertical inputs from the Front Panel Interface module.

5-93. A vertical preamplifier on the Interface module gives a vertical sensitivity of 10 millivolt per division and provides positioning and vernier gain capability for its input. The amplifier is preceded by a four decade range attenuator

5-76. The RF INPUT POWER and OVERTEMP signal lines from the RF input module provide the processor inputs for the internal wattmeter. (Paragraph 5-38). External wattmeter element inputs (EXT FWD PWR and EXT RFL PWR) from the front panel jack provide the information for the external wattmeter display.

5-77. A signal line from the DC input jack on the rear panel (BATT VOLT) is brought to the processor for battery voltage determination. The voltage is attenuated by a factor of 10 to stay within the 10 volt maximum input to the select switch. The processor uses the battery voltage measurement to warn the operator when the battery is near its discharged state.

5-78. A rectified and filtered version of the input to the 1 kHz NOTCH FILTER is the last internal measurement point. This measurement is used as part of the distortion/SINAD reading. For further information on the distortion/SINAD meter see paragraph 5-82.

5-79. EXTERNAL DVM — In the external DVM mode, voltages applied to the Ext DVM input Jack on the front panel are ranged by processor control over four decades in the Front Panel Interface (A12) module. The result is a 0 to 1 VRMS signal at the output of the attenuator for inputs of 0 to 300 VRMS. The signal is routed directly through the A3 module by the RMS/Distortion Select Switch to the RMS to DC Converter on the A7 module. The INT/EXT DVM Select Switch applied the output of the RMS to DC Converter to the A/D converter for input to the processor.

5-80. For external DC measurements the AC/DC Select Switch selects the DC coupled path from the Ext DVM input Jack. A low pass filter (LPFL) in the A12 module removes ripple components. The rejection at 50 Hz is 25 dB in the low pass filter. The RMS to DC Converter reads the absolute value of the DC input, and the sign detector (SIGN DET) provides polarity information.

5-81. For AC voltage measurements the LPFL is reprogrammed for less than 0.5 dB attenuation out to 10 kHz. The AC/DC Select Switch selects the AC coupled path, and the RMS to DC Converter converts the AC input into a DC voltage equal to the RMS voltage of the input.

5-82. Distortion/SINAD Meter

5-83. The distortion of a signal with a 1 kHz fundamental frequency can be measured by the R2001C. The 1 kHz input enters the EXT DVM input jack through the AC coupled path and is ranged to between 0 and 1 volt RMS by the ranging attenuator. The signal is routed through the notch filter where the fundamental frequency is removed. The output of the notch filter is selected to the RMS to DC Converter input by the RMS/Distortion Select Switch where the RMS voltage of the distortion components (to 10 kHz) is measured. The input of the notch is rectified, filtered, and multiplied by 1.11 (the RMS to AVERAGE ratio for a sinusoid). The resulting DC voltage is measured by the internal DVM as described in paragraph 5-73. The processor divides the RMS output voltage of the notch filter by the RMS input voltage to the notch filter to obtain a distortion ratio. The distortion ratio is converted to dB by the processor for the SINAD display. The percent distortion display is obtained by multiplying the distortion ratio by 100.

5-84. Oscilloscope

5-85. Three basic functions are provided for by the system oscilloscope. The alphanumeric and modulation displays provide operating mode and control information for the system. The external oscilloscope feature augments the total system as a general purpose test instrument. A block diagram of the oscilloscope function is shown in figure 5-11.

5-86. Drive signals for the CRT are provided by circuits on the Scope Amplifier module (A2). Horizontal and vertical signals are amplified by their respective amplifiers from 0.5 volt/division input levels to the levels required on the deflection plates. A Z-Axis Modulator circuit controls the cathode to grid bias voltage on the CRT to effect intensity control.

5-87. The horizontal amplifier input is selected between external and internal scope functions. External functions, Time Base Generator or external horizontal input, are switched to a summation amp where the HORIZONTAL POSITION signal from the front panel is added. The resulting DC offset positions the display horizontally on the CRT.

5-18

5-19

which is controlled from the front panel vertical switch through the processor. The attenuator provides external vertical input sensitivities from 0.01 to 1.0 volt per division and modulation scope sensitivities from 0.25 to 25 kHz per division

5-94. A Select Switch ahead of the Attenuator selects between the external vertical input or the modulation scope inputs. The External Vertical input path is further selected between AC and DC coupling before becoming the vertical input jack on the front panel. The modulation scope select path is switched to one of three possible sources on the Scope/DVM Control module. Demodulation signals from the Receiver are selected via the DEMOCAL AUDIO path, and frequency and amplitude modulation signals via the MOD CAL AUDIO and CARRIER + MOD LVL signal paths respectively. The Audio Synthesizer module provides the MOD CAL AUDIO signal while the RF input module gives the CARRIER + MOD LVL signal.

5-95. A Z-Axis Select circuit on the Scope/DVM Control module gates either the CHARACTER GEN signal for character displays or the retrace blanking signal from the Time Base Generator for scope displays to the Z-Axis Modulator on the Scope Amplifier module.

5-96. ALIGNMENT PROCEDURE

5-97. Introduction

5-98. This section provides a basic (para 5-102) and an extended (para 5-115) alignment procedure. The basic procedure requires only the use of a calibrated oscilloscope. It is expected that the basic alignment be performed whenever service work is performed. The extended alignment procedure requires module extenders and a calibrated digital voltmeter in addition to the oscilloscope. The extended procedure should be performed as required after servicing the system. All adjustments not covered in this procedure are to be performed on suitable module test fixtures only.

5-99. Test Equipment Required

5-100. The test equipment or its equivalent listed in table 5-3 is required for the basic procedure. The additional equipment required for the extended procedure is listed in table 5-4.

Table 5-3. Basic Test Equipment Required

Description	Model
*Oscilloscope	Motorola R1029A
Test Point Shorting Jumper	
Nonmetallic Alignment Tool	

*An R2001 is a suitable substitute

Table 5-4. Extended Test Equipment Required

Description	Model
*Oscilloscope	Motorola R1029A
*Digital Voltmeter	Motorola R1024A
*RF Signal Generator	Motorola R1201A
*Modulation Meter	Boonton 82AD
Audio Generator	Motorola S1067
Receiver Test Cover	Motorola 15-80346A49
Extender Card Set	Motorola RFX-4150A

*An R2001 is suitable for use in place of these separate equipments.

5-101. Preparation for Alignment

1. All alignments to be performed at normal ambient temperature.
2. Remove the top cover of the unit to be aligned.
3. Apply power to the unit to be aligned and allow a warmup time of 15 minutes prior to alignment.

5-102. Basic Alignment Procedure

5-103. CRT Astigmatism and Geometry

1. Select the Monitor Function and the Gen/Mon Mtr Display on the R2001C. Set the Intensity Control for a medium intense display.
2. While using the Focus Control to maintain a focused display at the center of the CRT, adjust the Astigmatism and Geometry potentiometers (Figure 5-12) for the best focus at the outer edges of the CRT while minimizing the pincushion and barrel distortion of the display. The two adjustments are interactive so that repeated small adjustments alternated between the two potentiometers will be required to obtain the best display.

5-104. CRT Intensity Bias

1. Select the Scope DC Display and the Ext Horiz. Input mode. Set the Intensity Control fully counter clockwise.
CAUTION
Do not let a dot stay in one place on the CRT screen for more than 30 seconds as a permanent burn in the phosphor will occur.
2. Adjust the Intensity Bias potentiometer (Figure 5-12) until a dot appears on the screen. (The Vertical and Horizontal Position Control on the front panel may have to be used to bring the dot on to the screen.) Then back off the Intensity Bias potentiometer until the dot just disappears.

5-105. CRT Intensity Balance

1. Select the Scope DC Display and the 1 mSec/Div Horizontal Sweep rate on the R2001C. Set the Horizontal Timebase Vernier to the Cal position and adjust the Intensity Control for a barely visible horizontal line on the CRT.
2. Adjust the Intensity Balance potentiometer (Figure 5-12) for uniform intensity of the horizontal trace from left to right. The Balance potentiometer affects the intensity on the left side of the trace.

5-106. CRT Horizontal Centering

1. Select the Gen/Mon Mtr Display on the R2001C. Adjust the Intensity Control for a comfortable viewing brightness.
2. With the Test Point Shorting Jumper connect TP1 of the Scope Amplifier Board (Figure 5-12) to chassis ground.
3. Adjust the Horizontal Position Potentiometer (Figure 5-12) so that the vertical trace on the CRT screen passes through the graticule center point.
4. Remove the jumper from TP1.

5-22

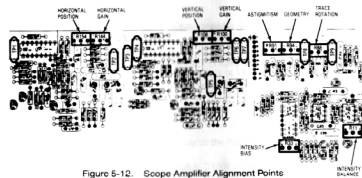

Figure 5-12. Scope Amplifier Alignment Points

5-111. Vertical Input Gain

1. Set the R2001C for the Generate FM Function and the Scope DC Display. Set the Horiz Control for 1m Sec/Div sweep rate and the Horizontal Vernier to the Cal position. Set the Vert Control for 1V/Div input sensitivity and the Vertical Vernier to the Cal position.
2. Connect an oscilloscope with a calibrated vertical input to the Mod Out Jack on the front panel.
3. Turn the Code Synthesizer off, the Ext Level off and adjust the 1 kHz Level Control for a 6V p-p sinewave on the attached oscilloscope.
4. Disconnect the oscilloscope from the Mod Out Jack and connect the Mod Out Jack to the Vert Input Jack on the R2001C.
5. Adjust the Input Vertical Gain Potentiometer on the Front Panel Interface Board (Figure 5-13) for a 6 cm p-p sinewave on the CRT. (Use the front panel Position Controls to center the waveform on the CRT.)

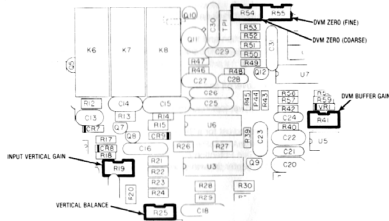

Figure 5-13. Front Panel Interface Alignment Points

5-24

5-107. CRT Vertical Centering

1. Select the Gen/Mon Mtr Display on the R2001C. Adjust the Intensity Control for comfortable viewing brightness.
2. With the Test Point Shorting Jumper connect TP4 of the Scope Amplifier Board (Figure 5-12) to chassis ground.
3. Adjust the Vertical Position Potentiometer (Figure 5-12) so that the horizontal trace on the CRT screen passes through the graticule center point.
4. Remove jumper from TP4.

5-108. CRT Trace Rotation

1. Select the Gen/Mon Mtr Display on the R2001C. Adjust the Intensity Control for a comfortable viewing brightness.
2. Adjust the Trace Rotation Potentiometer (Figure 5-12) for a properly rotated CRT display.

5-109. CRT Horizontal Gain

1. Connect the Mod Out Jack to the Ext Horiz Jack on the R2001C front panel.
2. Set the R2001C for the Generate FM Function and the Scope DC Display. Set the Horiz Control for Ext Horiz input. Turn the Code Synthesizer off, the Ext Level off, and the 1 kHz Level up about half way.
3. Connect an oscilloscope with a calibrated vertical input to TP1 on the Scope Amplifier Board. (Figure 5-12).
4. Using the front panel Horizontal Vernier Control adjust for a 3V p-p amplitude on the sinewave at TP1.
5. With 3V p-p at TP1 adjust the Horizontal Gain Potentiometer (Figure 5-12) for a horizontal trace 6 cm long on the CRT. (Use the front panel controls to position the trace at a convenient place near the center of the CRT).

5-110. CRT Vertical Gain

1. Connect the Mod Out Jack to the Vert Input Jack on the R2001C front panel.
2. Set the R2001C for the Generate FM Function and the Scope DC Display. Set the Horiz Control for 1 mSec/Div sweep rate and the Horizontal Vernier to the Cal position. Set the Vert Control for 1 V/Div input sensitivity and the Vertical Vernier to the Cal position.
3. Turn the Code Synthesizer off, the Ext Level off and the 1 kHz Level up about half way.
4. Connect an oscilloscope with a calibrated vertical input to TP4 on the Scope Amplifier Board. (Figure 5-12).
5. Using the front panel 1 kHz Level Control adjust for a 3V p-p amplitude on the sinewave at TP4.
6. With 3V p-p at TP4 adjust the Vertical Gain Potentiometer (Figure 5-12) for a 6 cm p-p sinewave on the CRT. (use the front panel Position Controls to center the waveform on the CRT).

5-23

5-112. DVM Zero

1. Select the DVM Display and the DC Mode on the R2001C.
2. Short the center conductor of the DVM Input Jack to ground.
3. Adjust the DVM Zero (Coarse) and the DVM Zero (Fine) Potentiometers on the Front Panel Interface Board (Figure 5-13) for a zero reading on the DVM Display.

5-113. Spectrum Analyzer Centering

1. Select the Spect Analyzer Display on the R2001C. Set the Dispersion Control on the front panel to the 1 MHz position. (full counter clockwise) Set the center frequency of the analyzer to 10.0 MHz.
2. Connect the 10 MHz Output on the rear panel to the RF Input on the front panel. Set the RF Step Attenuator to obtain a convenient spectral display.
3. Adjust the Spectrum Analyzer Centering Potentiometer on the Scope/DVM Control Board (Figure 5-14) so that the spectral line on the CRT is centered about the center graticule line.

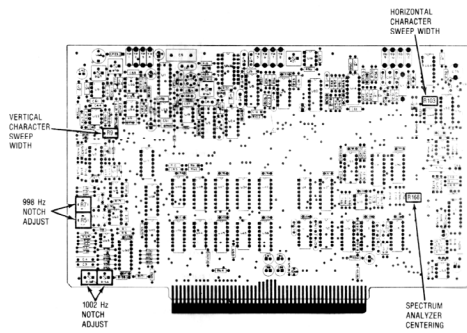

Figure 5-14. Scope/DVM Control Alignment Points

5-25

5-114. Horizontal Time Base

1. Select the Tone Memory Display and the Generate FM Function on the R2001C. Program tone A for 20.0 Hz and Tone B for 2000.0 Hz.
2. Select the Modulation Display. Set the Oscilloscope Controls for 2.5 kHz/Div vertical range, Auto Trigger, and 10 mSec/Div horizontal sweep range. Set the Horizontal and Vertical Vernier Controls to their Cal positions.
3. Set the Code Synthesizer for continuous, tone A, and turn up the Code Synth Level to obtain a nearly full scale sinusoidal waveform on the CRT. Turn the Ext Level and the 1 kHz Level Controls to the off position.
4. Adjust the Coarse Time Base Calibration Potentiometer on the Scope Amplifier Board (Figure 5-15) so that one cycle of the displayed waveform occurs in 5 cm along the horizontal axis. Use the Vertical and Horizontal Position controls to center and to move the waveform so that the 5 cm are measured in the middle of the screen to avoid nonlinearities near the edge of the CRT.
5. Set the Oscilloscope Horizontal Control for a 100 μ Sec/Div sweep rate and select the Tone B output on the Code Synthesizer.
6. Adjust the Fine Time Base Calibration Capacitor on the Scope Amplifier Board (Figure 5-15) so that one cycle of the displayed waveform occurs in 5 cm along the horizontal axis. Use the Vertical and Horizontal Position controls to center and to move the waveform so that the 5 cm are measured in the middle of the screen to avoid nonlinearities near the edge of the CRT.

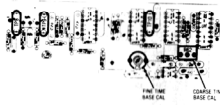

Figure 5-15. Horizontal Time Base Alignment Points

5-115. EXTENDED ALIGNMENT PROCEDURE

5-116. DVM

1. Remove the R2001C top cover.
2. Connect the R2001C to a primary power source, turn it on, and select the EXT DVM mode. Allow approximately 15 minutes warmup before proceeding with the alignment procedure.
3. Short the center conductor of the DVM input jack on the front panel to ground. Connect an external DVM between TP2 and TP9 of the Scope/DVM Control Board (Figure 5-14).
4. Adjust the Coarse DVM Zero and the Fine DVM Zero on the Front Panel Interface Board (Figure 5-13) until the external DVM reads 0 \pm 0.5 millivolts DC.
5. Remove the short circuit on the DVM input jack and apply approximately 0.900 volts DC from an external power supply. The voltage between TP2 and TP9 of the Scope/DVM Control Board should be within \pm 1 mV of the voltage at the front panel DVM input jack. If the unit fails this test, adjust the DVM Buffer Gain on the Front Panel Interface Board (Figure 5-13) until the above two voltages are equal.

5-26

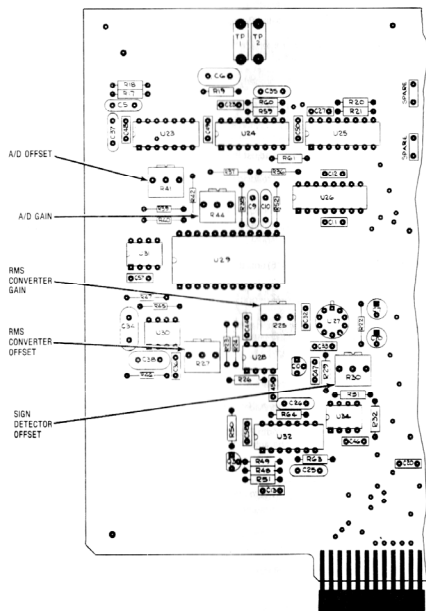

Figure 5-16. Processor I/O A/D Alignment Points

5-28

6. Select the generate FM narrowband mode and the Gen/Mon Metering display.

7. Short TP4 to TP9 on the Scope/DVM Control Board.

8. Adjust the A/D Offset on the Processor Interface Board (Figure 5-16) until the plus peak deviation reading on the CRT is just toggling between 0.00 and 0.01 kHz. Then slightly turn the adjustment just enough to make the reading 0.00 all the time. Note that if the offset adjustment is turned past this point the deviation reading is still 0.00 but the A/D converter is not aligned properly.
9. Remove the short circuit between TP4 and TP9, and connect the positive lead of the external DVM to TP4 of the Scope/DVM Control Board module. Place the negative lead on the ground plane or TP9 of the Scope/DVM Control Board.
10. Turn on the 1 kHz internal modulation and adjust the level until the voltage TP4 reads 0.900 volts.
11. Adjust the A/D Gain (Figure 5-16) until the reading on the positive deviation peak is 4.50 kHz.
12. Select the DC DVM mode.
13. With the center conductor of the front panel DVM input jack again shorted to ground, adjust the RMS Converter offset on the Processor Interface Board (Figure 5-16) for a reading of 0.000 volts on the CRT DVM display.
14. Adjust the sign detector offset (Figure 5-16) until the sign of the 0.000 volt reading is just flashing between plus and minus.
15. Remove the short and apply approximately 0.900 volts to the front panel, DVM input jack.
16. While monitoring the input voltage on an external DVM, adjust the RMS Converter Gain on the Processor Interface Board (Figure 5-16) until the CRT DVM reading is equal to the external voltage applied.

5-117. Character Generator

1. Perform the Basic Alignment Procedure of para 5-102.
2. Select the Monitor FM Function and the Gen/Mon Mtr Display.
3. Adjust the Horizontal Character Sweep Width Potentiometer on the Scope/DVM Control Board (Figure 5-14) so that the right-hand edge of the CRT character display is approximately 4.2 graticule divisions to the right of the graticule center line.
4. Adjust the Vertical Character Sweep Width Potentiometer on the Scope/DVM Control Board (Figure 5-14) so that the bottom edge of the CRT display is approximately 3.3 graticule divisions below the graticule center line.

5-27

5-118. DISTORTION/SINAD ALIGNMENT

1. Enter the generate mode and the Gen/Mon Metering display. Using an audio generator with less than 0.1% distortion apply a 900 mVRMS 1 kHz \pm 2 Hz signal to the Vert Sinad/DVM Dist/Counter In input on the front panel.
2. Verify that the distortion reading on the CRT is $<$ 0.5%. If this test fails the notch filter should be aligned.
3. Turn the R2001C off and extend the Scope/DVM Control Board using the 100 pin extender card.
4. Turn the R2001C on and select the generate FM mode and the Gen/Mon Metering display.
5. Using the same low distortion generator as in article 1, apply a 998 \pm 0.2 Hz sine wave to the Distortion input.
6. Alternately adjust the 998 Hz notch potentiometers on the Scope/DVM Control Board (Figure 5-14) to null the distortion reading on the CRT. A reading less than 0.5% should be obtained.
7. Change the audio generator input frequency to 1002 \pm 0.2 Hz.
8. Alternately adjust the 1002 Hz notch potentiometers on the Scope/DVM Control Board (Figure 5-14) to again null the CRT distortion reading. A reading less than 0.5% should be obtained.
9. Turn the system power off and reinstall the Scope/DVM Control Board into the R2001C.

5-119. Receiver

5-120. AM Detector

1. Perform the basic alignment procedure of para 5-102.
2. Turn the R2001C off and remove the Receiver Module. Remove the Receiver Module cover and install the Receiver Test Cover on the module housing. Extend the Receiver module on the Receiver Extender Card.
3. Turn the R2001C on and select the Monitor AM Function and the Gen/Mon Mtr Display. Set the monitor frequency to 250 MHz, the RF Step Attenuator to the 0 dB position, and the BW Switch to the Narrow position.
4. Connect the external signal generator to the RF In/Out Jack on the front panel. Adjust the external generator for an output level of approximately -60 dBm and a calibrated 30% AM.
5. Adjust R60 (Marked on the Receiver Test Cover) for a reading of 30% \pm 5% on the CRT AM display.

5-121. FM Detector

1. Select the Monitor FM Function and the Gen/Mon Mtr Display. Set the monitor frequency to 250 MHz, the RF Step Attenuator to the 0 dB position, and the BW Switch to the Wide position.
2. Connect the external signal generator to the RF In/Out Jack on the front panel. Adjust the external generator for a center frequency of 250 MHz at an output level of approximately -30 dBm and a calibrated 20 kHz FM.
3. Adjust R70 (Marked on the Receiver Test Cover) for a reading of 20 kHz \pm 1 kHz on the CRT FM display.
4. Set the BW switch to the Narrow position and reset the FM on the external generator to 3 kHz deviation.
5. Adjust R125 (Marked on the Receiver Test Cover) for a reading of 3 kHz \pm 150 Hz on the CRT FM display.

5-29

6. Turn off the FM on the external generator so that a CW signal of a level of approximately -30 dBm is applied to the R2001C.
 7. Connect the Demod Out Jack to the Vert/Sinad Dist/DVM/Counter Input Jack on the front panel. Select the DVM Display and the DC DVM Mode on the R2001C.
 8. Adjust R68 (Marked on the Receiver Test Cover) for a 0.0 VDC ± 100 mVDC reading on the DVM Display.
- 1-122. Spectrum Analyzer
1. Select the Monitor Function and the Spectrum Analyzer Display on the R2001C. Set the monitor frequency to 250 MHz, and the RF Step Attenuator to the 40 dB position.
 2. Connect the external signal generator to the RF In/Out Jack on the front panel. Adjust the external generator for a center frequency of 250 MHz and a calibrated output level of -30 dBm with no modulation.
 3. Adjust in succession C2, C83, C88, and C96 (Marked on the Receiver Test Cover) to maximize the amplitude of the spectral line in the center of the CRT display.
 4. Adjust R124, R91, and R100 (Marked on the Receiver Test Cover) to obtain a uniform change in the spectral amplitude per 10 dB change of the RF Step Attenuator. R124 affects the level of the spectral component when in the top quarter of the screen, R91 affects levels in the third quarter from the top, and R100 affects levels in the bottom quarter.
 5. Adjust R119 for offset and R121 for gain so that with the step attenuator in the 0 dB Position the peak of the spectral line lies on the 30 dB line of the CRT and that successive step increases of the input attenuator move the spectral amplitude downward in 10 dB increments on the CRT. The accuracy required for any one step attenuator position is ± 3 dB.
 6. It will generally be necessary to repeat paragraphs 5-122.4 and 5-122.5 until the best possible accuracy is obtained.
 7. Turn the power off and remove the Receiver Module and the Receiver Extender for the chassis. Remove the Test Cover from the Receiver Module and replace the module cover. Reinstall the Receiver Module into the system chassis.

I-123. CHECKOUT PROCEDURE

I-123. Introduction

I-125. This section provides a system checkout procedure. This procedure will help isolate system failures when used with the troubleshooting information in para 5-143.

5-30

3. Move the Modulation Switch to the BURST position. Verify that a 133 Hz tone is output as long as the switch is held in the BURST position.
4. Select the Tone A Continuous Mode. Verify a Tone A output on the scope and at the speaker.
5. Select the Tone Remote Mode. Verify that when the Modulation Switch is moved from OFF to BURST that a single Tone Remote Access Sequence is generated.
6. Connect a microphone to the Mic Jack. Turn up the Ext Level Control and verify that speaking into the mike causes a modulation signal to be output as observed on the scope display.

5-133. Frequency Counter

1. Set the UUT to the Gen CW Mode with an output frequency of 35 MHz at a level of 0 dBm as displayed on the Gen/Mon Mtr display. Connect the RF In/Out Jack to the Counter In Jack of the UUT. Select the Frequency Counter Display and verify a frequency reading of 35 MHz.
2. Set the UUT to the Generate FM Mode and select the Gen/Mon Mtr Display. Turn the Code Synthesizer and Ext Modulation sources OFF. Select the Narrow Band Mode and adjust the 1 kHz Level Control for a 5 kHz FM deviation reading. Connect the Mod Out Jack to the Counter Input Jack of UUT. Select the Frequency Counter Display and verify a nominal frequency reading of 1 kHz.

5-134. DVM

1. Maintaining the same conditions as in paragraph 5-133.2, select the DVM Display and the AC Mode on the display. Verify a DVM reading of 0.707 v rms ± 0.04 v rms.
2. Select the DC Mode and verify a near zero volt DC reading.

5-135. Scope Mode

1. Set the UUT to the Scope AC display mode and connect the scope vertical input jack to the Mod Out Jack. Enable the internal 1 kHz modulation source. Verify the operation of each position of the vertical input range switch and the vertical vernier gain control.
2. With the same connection as in paragraph 5-135.1, verify the operation of each position of the Horizontal Control and the Horizontal timebase vernier.
3. With the Horizontal Control set to the External Mode, connect the External Horizontal jack to the Mod Out Jack. Verify a horizontal line whose length is variable with the Horizontal vernier.
4. Connect the Vert In jack to the Mod Out jack on the UUT. Set the vert and horizontal controls for a convenient display. Verify that a steady sync is obtained in either the Norm or Auto modes and that the point of triggering is adjustable with the level control. Remove the input signal and verify no horizontal sweep in the Norm mode and the presence of a horizontal sweep in the Auto mode.

5-136. Distortion/SINAD Meter

1. Set the UUT for the Generate FM Function, Narrow Band Mode, and the Tone Memory Display. On the Tone Table set Tone A for 2000.0 Hz.
2. Select the Gen/Mon Mtr Display and the Tone A Cont Modulation Mode. Turn the Ext Level and the 1 kHz Level Controls Off. Adjust the Code Synth Lvl Control for an FM deviation of 1.88 kHz as read on the CRT display.

5-32

5-126. Test Equipment Required

- 5-127. The test equipment listed in table 5-5 or its equivalent will be required to perform the checkout procedure.

Table 5-5. Test Equipment

*RF Signal Generator	Motorola R-1201A
*RF Power Meter	Motorola S-1339A
*SINAD Meter	Motorola R-1013A
*Modulation Meter	Boonton 82AD
RF Power Source	1 watt to 100 watts

*An R2001 is suitable for use in place of these separate equipments.

5-128. Procedure

5-129. Power On

1. Check that the AC input power select card is in the 120 V position. Connect the Unit Under Test (UUT) to a 120 VAC line source with the front panel power switch off. Verify the presence of an AC indication on the front panel.
2. Set the power switch to the Standby Position. Verify the oven ready indicator is on.
3. Set the power switch to the on position. Verify that after a warm-up period a display is visible on the CRT.

5-130. Keyboard Check

1. Verify that each key has the proper effect by observing the Gen/Mon Mtr Display and entering the frequency 123.4567 MHz and the PL frequency 890 . Check for proper cursor key operation.
2. Verify that the up and down display keys perform properly and that the LED at each display illuminates.
3. Verify that the up and down function keys perform properly and that the LED at each function illuminates.
4. Verify that the up and down modulation keys perform properly and that the LED at each modulation mode illuminates.

5-131. Nonvolatile Memory

1. Select some random combination of Display, Function, and Modulation Modes. Simultaneously depress both cursor keys and after a five second delay turn the system power OFF. Turn the system power back ON and verify that the same Display, Function, and Modulation Modes are present.

5-132. Modulation capability

1. Set the UUT to the Generate FM Mode and select the Gen/Mon Mtr Display. On the Gen/Mon Mtr Display enter a DPL code of 111 . Select the Oscilloscope Display and connect the Mod Out Jack to the Vert In Jack. Set the code synthesizer to the Cont PL/DPL Mode. On the scope verify the presence of a DPL waveform whose amplitude is variable with the code synthesizer level control.
2. Move the Modulation switch from CONT to OFF and verify that a short burst of 133 Hz is output before the output stops.

5-31

3. Without disturbing the Code Synth Lvl Control, turn the Code Synthesizer OFF. Turn On the 1 kHz Level Control and adjust for an FM deviation of 7.5 kHz on the CRT display.
4. Connect the Mod Out Jack to the SINAD Input Jack on the UUT. Verify a SINAD reading greater than 25 dB.
5. Set the Code Synthesizer to the Continuous Mode and verify a SINAD reading 12 dB ± 1 dB.

5-137. Scan Mode

1. Set the UUT for the Gen/Mon Mtr display. Verify the proper operation of each of the RF Scan switch positions.

5-138. Generate Mode

1. Set the UUT for the Generate FM Mode at 200 MHz and select the Gen/Mon Mtr display. Verify an RF level output display on the CRT.
2. Connect the RF millivoltmeter with a 50 ohm termination to the RF In/Out Jack on the UUT. Set the RF step attenuator to the 0 dB position and adjust the Variable Level Control to obtain a displayed output level of $+13$ dBm. Verify that the RF millivoltmeter reads $+13$ dBm ± 2 dBm.
3. Repeat paragraph 5-138.2 except at a center frequency of 800 MHz.
4. Increase the RF Step Attenuator setting in 10 dB increments and verify that the displayed RF level decreases in 10 dB increments.
5. Set the Code Synthesizer Modulation switch and the Ext Level Control to their respective OFF positions. Select the Narrow Band mode and adjust the 1 kHz Level Control for a 5 kHz deviation reading on the CRT display. Verify a 1 kHz tone at the speaker output.
6. Connect the Modulation Meter to the RF In/Out Jack on the UUT. Set the Modulation Meter for a deviation display of 5 kHz ± 250 Hz.
7. Select the Wide Band mode on the UUT and verify that the CRT displays a deviation of 20 kHz. Also verify that the Modulation Meter shows a peak deviation of 20 kHz ± 1 kHz.
8. Select the Modulation Display on the UUT and verify a peak-to-peak modulation display of 40 kHz ± 2 kHz.
9. Select the Generate CW Function and verify that no modulation is present on the CRT.
10. Set the UUT for the Generate AM Function, the Gen/Mon Mtr Display, and adjust for an RF output level of 0 dBm. Adjust the 1 kHz Level Control for a 50% AM reading on the CRT. Verify that the Modulation Meter reads $50\% \pm 10\%$ AM.
11. Select the Modulation Display and verify a low distortion 1 kHz sine wave.
12. Set the UUT for the Generate SSB/DSBSC Function and verify a low distortion 1 kHz sine wave on the CRT.
13. Set the UUT for the Generate SWP $1-10$ MHz Function and the Scope DC Display. Verify a horizontal trace and a center frequency display on the CRT.
14. Set the UUT for the Generate SWP $0.01 - 1$ MHz Function and verify the same results as paragraph 5-138.13.

5-33

5-139. Power Monitor Mode

1. Set the UUT to the Power Monitor Mode. Set the RF Step Attenuator to the 30 dB position, and select the Gen/Mon Mtr Display. Connect the RF power source to the RF In/Out Jack. Key the power source and verify a correct power reading on the CRT display. Unkey the power source.
2. Set the UUT to the Monitor Function and verify that the RF Step Attenuator is in the 30 dB position. Key the RF power source and verify the presence of an audible alarm and a warning display on the CRT. Unkey the power source.

5-140. Monitor Mode

1. Set the UUT to the Monitor FM Function. Set the Squelch Control to the OFF position and verify the presence of a Sig Lvl indication and noise at the speaker. Turn the Squelch Control full on and verify the absence of a Sig Lvl indication and noise at the speaker.
2. Repeat paragraph 5-140.1 except for the AM function.
3. Repeat paragraph 5-140.1 except for the SSB/DSBSC Function and enable the BFO. After the test turn the BFO off.
4. Select the Narrow Band FM Monitor Function at 300 MHz and set the RF Step Attenuator to the 0 dB position. Connect the RF Signal Generator to the RF In/Out Jack and the SINAD Meter to the Demod Out Jack. Set the RF Signal Generator for a center frequency of 300 MHz and for 3 kHz FM at a 1 kHz rate. Adjust the RF output level from the Signal Generator for a 10 dB reading on the SINAD Meter. Verify that the Signal Generator's level is less than -103 dBm (1.5 μ Vrms).
5. Calibrate the RF Signal Generator for 3 kHz FM at 1 kHz rate using the Modulation Meter. Set the Generator for a nominal output level of -60 dBm and connect it to the RF In/Out Jack of the UUT. Select the Gen/Mon Mtr Display and verify a monitor deviation reading of 3 kHz \pm 150 Hz.
6. Calibrate the RF Signal Generator for 50 kHz FM at a 1 kHz rate. Select the Wide Band Mode on the UUT and verify a reading of 50 kHz \pm 2.5 kHz on the CRT deviation display.
7. Calibrate the RF Signal Generator for 30 % AM at a 1 kHz rate. Set the Generator for a nominal output level of -60 dBm and connect it to the RF In/Out Jack of the UUT. Select the Monitor AM Function and the Narrow Band Mode. Verify a monitor AM reading of 30% \pm 5%.
8. Monitor the % AM Displayed on the CRT while increasing the RF level out of the Signal Generator. Verify that the IF Overload Warning occurs before the displayed AM exceeds a reading of 30% \pm 5%.
9. Select the Modulation Display on the UUT and verify the presence of the received modulation signal.
10. Select the Gen/Mon Mtr Display and the Wide Band Mode on the UUT. Vary the center frequency on either the UUT or the Signal Generator and verify that the Frequency Error Display properly represents the difference between the UUT's Center frequency and the Signal Generator's center frequency.
11. Select the IF Display on the UUT and verify the presence of an IF envelope on the CRT.

5-34

5-141. Spectrum Analyzer

1. Set the UUT for the Monitor Function at 300 MHz the Spectrum Analyzer Display, and 0 dB input attenuation. Connect the Signal Generator to the RF In/Out Jack on the UUT. Verify a spectral amplitude of -30 dBm \pm 5 dB on the CRT display. Increase the RF Step Attenuator in 10 dB increments verifying that the spectral amplitude decreases by 10 dB \pm 3 dB with each step.
2. Verify the operation of the Dispersion Control.

5-142. Duplex Generator

1. Select the Duplex Generator Display and the Monitor Function at a frequency of 100 MHz. Enable the 45 MHz offset frequency. For an Image Low switch position verify that a displayed duplex frequency of 55 MHz can be obtained. Set the Image Switch to the HIGH position and verify a duplex frequency display of 145 MHz.
2. Enable the 0 - 10 MHz offset frequency and verify that displayed duplex frequencies from 100 MHz to 110 MHz can be obtained.
3. Set the UUT to the Generate Function with the Duplex Generator Display. With the Code Synthesizer and the External Modulation sources OFF, adjust the 1 kHz Level Control for a 20 kHz FM deviation reading on the CRT. Select the Monitor Function and adjust the offset frequency for a duplex output of 100 MHz. Connect the Duplex Output Jack to the RF In/Out Jack and verify a 20 kHz \pm 1 kHz FM deviation reading on the CRT.

5-143. System Troubleshooting

5-144. A troubleshooting procedure is outlined in Table 5-6. Because of the complexity of the system the table covers only the major failures and provides only a guide to the most probable failed module. When using the table it is important to use the checkout procedure at paragraph 5-123 to determine the fault. The troubleshooting table assumes that all tests prior to the failure point have been successfully completed and thus the applicable circuits are okay.

5-145. A list of the system test points and their functions are provided in Table 5-7. Test points are identified on the block diagrams for the Theory of Operation discussion of paragraph 5-16 and for the Module Descriptions to aid in troubleshooting.

Table 5-6. System Troubleshooting

Test Paragraph	Fault	Troubleshooting Procedure
5-129	No AC indication	1. Check AC inecord and line fuse. 2. If system powers up normally when on, Replace AC LED.
5-129	No Oven Ready indication	1. Check for approximately +15 VDC at E13 of the A13 module. If not present replace the Low Voltage Power Supply (A1). 2. Check E11 of A13 for +9 VDC and E12 for approximately +7.5 VDC. If E11 is okay and E12 is 0 VDC, replace the LED. If the +9 VDC is not present on E11 replace A13.

5-35

Table 5-6. System Troubleshooting (Cont)

Test Paragraph	Fault	Troubleshooting Procedure
5-129	System won't turn on	1. Disconnect the high voltage supply from the low voltage supply at A10P1. Check for nominal voltages of 15 VDC at pin 3 of U2 on the low voltage supply and for +12 VDC at pin 8. If either voltage is not present replace the low voltage supply (A1). 2. Reconnect the low voltage/high voltage interface and check for a nominal +9 VDC on the collectors of Q3 and Q4. (The actual signal on the collectors is a 0 VDC to +18 VDC square wave). If 9 volts is not present replace the high voltage supply (A10). 3. If items 1 and 2 check okay replace the low voltage supply (A1).
5-129	System turns on, but no display on the CRT for any display mode	1. Check for presence of high voltage by disconnecting the CRT anode lead and arcing it to the chassis. If no arc, replace the high voltage supply. 2. If the high voltage supply is okay, replace the CRT.
5-130	More than one key is inoperative or has the wrong effect	1. Replace the Processor Module (A9).
5-130	Only one key is inoperative	1. Replace the defective key switch.
5-131	Any part of the nonvolatile memory fails to remember	WARNING Lithium Battery Do not mutilate or disassemble the battery cell. The lithium metal is a very active material that burns in the presence of water or high humidity. Do not put the battery in fire, attempt to charge, heat above 100°C, or solder directly to the cell. Do not overdischarge the cell to a reverse voltage greater than 3 volts. The battery may burst and burn or release hazardous materials. 1. Troubleshooting Instructions: A. Turn system power switch off and disconnect the unit from the primary power source. B. Remove the Processor Module (A9) from the system and place on a non-conductive surface. C. With a voltmeter measure the DC voltage across the lithium battery in the lower left corner of the board.

5-36

Table 5-6. System Troubleshooting (Cont)

Test Paragraph	Fault	Troubleshooting Procedure
		D. If the battery voltage is less than 2.4 volts, the cell is discharged and should be replaced. If the battery is okay, replace the entire Processor Module (A9). E. If a new battery is needed, obtain a new cell (P/N60-80396A0) from Motorola. Replace the battery using the procedure in Part 2. CAUTION Do not substitute another type lithium battery as a replacement. The specified battery was chosen with safety as a major consideration. Other lithium battery types may present a potential hazard when used in this system. 2. Replacement Instructions: A. Turn system power switch off and disconnect the unit from the primary power source. B. Remove the Processor Module (A9) from the system and place on a nonconductive surface. C. Cut each of the two wires connecting the battery to the circuit board near each battery end. D. Remove the battery from the hold-down clip. E. Remove the new battery from its shipping container and put the old battery into the shipping container. Dispose of the battery as per Part 3. F. With a 40-watt or lower watt soldering iron remove the old battery leads from the board. G. Using care not to short the battery leads to each other or to the battery case, install the battery into the hold-down clip with the negative lead nearest the left edge of the card (circuit board connector edge toward you). H. Solder the leads from the new battery into the printed wiring board at the points where the old leads were removed from. I. Trim the lead ends and reinstall the module into the system.

5-37

Table 5-6. System Troubleshooting (Cont)

Test Paragraph	Fault	Troubleshooting Procedure
5-132	No DPL (modulation) signal on CRT	<p>3. Disposal Instructions</p> <p>A. Do not dispose of the lithium battery by placing it in the everyday trash. Lithium batteries are classified as hazardous material and must be disposed of accordingly.</p> <p>B. Consult State and Local Codes for the appropriate procedure to be used for disposal.</p> <p>C. Motorola will dispose of the battery for you if you send it in the shipping container and by the same method that the new battery came to you to:</p> <p>Motorola, Inc. Return Goods Department 1313 East Algonquin Road Schaumburg, Ill 60196</p> <p>1. Check TP1 of the Audio Synthesizer for the presence of the DPL signal. If not present replace the Audio Synthesizer module.</p> <p>2. Check for the DPL signal on pin 64 of the Audio Synthesizer. If not present replace the IEEE interface module (A8), or check for the presence of the jumpers on J8 for the standard unit.</p> <p>3. Check for the DPL signal at 1P6 of the Audio Synthesizer. If not present replace the Audio Synthesizer (A6).</p> <p>4. Check for the DPL signal at TP4 of the Scope Amplifier module (A2). If not present replace the Scope/DVM control module (A3).</p> <p>5. If signal switching is okay to the Scope Amplifier module proceed to the scope troubleshooting information.</p>
5-132	No external modulation on the CRT	<p>1. Check for modulation signal at TP7 of the Audio Synthesizer module (A6). If not present replace the Audio Synthesizer module.</p>

5-38

Table 5-6. System Troubleshooting (Cont)

Test Paragraph	Fault	Troubleshooting Procedure
5-135	No horizontal sweep See "CAUTION" note on page 4-19	<p>1. Check for a voltage level between -2.0 VDC and +2.0 VDC at TP4 of the Scope Amplifier module (A2). If the voltage cannot be brought within range with either the vertical range attenuator or the vertical position control replace the Front Panel Interface module (A12).</p> <p>2. If the voltage at TP4 is okay replace the Scope Amplifier module (A2).</p>
5-135	No vertical display	<p>1. Check for the input signal at TP4 of the Scope Amplifier Module (A2). If not present replace the Front Panel Interface Module (A12)</p> <p>2. If signal is okay at TP4 replace the Scope Amplifier Module (A2).</p>
5-135	No vertical sync	<p>1. Check for the presence of sync pulses at pin 12 of the Scope/DVM Control module (A3) and for a nominal zero volt sync present level at pin 76. If either signal is not present replace the Scope/DVM Control module.</p> <p>2. If sync pulse and the syn present lines are okay replace the Scope Amplifier Module (A2).</p>
5-136	Distortion/SINAD meter inoperative	<p>1. If the DVM mode checks okay replace the Scope/DVM Control module (A3).</p> <p>2. If the DVM mode does not check okay go to the troubleshooting list for DVM AC inoperative.</p>
5-138	No generate output	<p>1. Remove the RF cable between the RF Synthesizer (A5) and the RF Input module (A11). Check for a nominal -10 dBm level at the Synthesizer output. If no output replace the RF Synthesizer.</p> <p>2. If the Synthesizer output is okay replace the RF input module (A11).</p>
5-138	No Frequency Modulation	<p>1. Check for modulation signal at pin 56 of the RF Synthesizer (A5). If the signal is okay replace the RF Synthesizer.</p> <p>2. If the modulation signal is not present proceed to the troubleshooting list under "no DPL (modulation) signal on CRT".</p>

5-40

Table 5-6. System Troubleshooting (Cont)

Test Paragraph	Fault	Troubleshooting Procedure
5-133	Frequency Counter inoperative	<p>2. Check for the modulation signal on pin 66 of the Audio Synthesizer. If not present replace the IEEE Interface module (A8), or check for the presence of the modulation jumpers on J8 for the standard unit.</p> <p>3. Continue troubleshooting at step 3 of the "no DPL signal on the CRT".</p> <p>1. Check for presence of a 1 kHz signal at TP9 of the Audio Synthesizer (A6). If not present check for the 10 MHz signal from the Frequency Standard module (A13) to the RF Synthesizer (A5). If present replace the RF Synthesizer. If not present replace the Frequency Standard module.</p> <p>2. If the 1 kHz signal is present check for the presence of the signal to be counted at pins 61 and 63 of the processor I/O module (A7). If not present replace the Front Panel Interface Module (A12).</p> <p>3. If signal is okay up to the Processor I/O module replace the Processor I/O module.</p>
5-133	DVM AC mode is inoperative	<p>1. Check for DVM signal at pin 22 of Front Panel Interface module (A12). If not present replace the Front Panel Interface module.</p> <p>2. Check for short bursts of the DVM AC signal at TP2 of the Scope/DVM Control module (A3). If signal is not present at TP2 replace the Scope/DVM Control module.</p> <p>3. If the signal is okay to TP2 of A3, replace the Processor I/O module (A7).</p>
5-134	DVM DC mode is inoperative	<p>1. Check for the DC input level attenuated by factors of 10 to less than 1 volt at pin 22 of the Front Panel Interface module (A12). If not present or if greater than 1 volt, replace the Front Panel Interface module.</p> <p>2. Check for same voltage at TP2 of A3. If signal not present, replace A3.</p> <p>3. If signal is present at TP2, replace Processor I/O module A7.</p>

5-39

Table 5-6. System Troubleshooting (Cont)

Test Paragraph	Fault	Troubleshooting Procedure
5-139	Internal wattmeter in error	<p>1. Replace RF input module (A11).</p>
5-140	No monitor function	<p>1. Apply a 10.7 MHz modulated carrier to the RF input. Check for normal receiver operation except reduced sensitivity. If receiver is not working replace the Receiver module (A4).</p> <p>2. If the receiver checks okay and the generate function is okay, replace the RF Input module (A11).</p>
5-140	Monitor frequency error display is missing	<p>1. Go to the troubleshooting list under "frequency counter inoperative".</p>
5-140	Monitor frequency error is in error	<p>1. Check for presence of IF signal at pin 91 of the Scope/DVM Control module (A3). If not present replace the Receiver module (A4).</p> <p>2. If the IF signal is present replace the Scope/DVM Control module.</p>
5-141	No spectrum analyzer sweep	<p>1. Check pin 6 of the RF Synthesizer module (A5) for a 50 Hz square wave. If not present replace the RF Synthesizer module.</p> <p>2. If 50 Hz signal is present replace the Scope/DVM Control module (A3).</p>
5-141	Spectrum display is in error	<p>1. Replace the Receiver module (A4).</p>
5-142	No duplex output	<p>1. Replace the RF input module (A11).</p>

5-41

Table 5-7. Test Point Identification

Test points are located near the top edge of the card and counted from left to right when facing the component of the card.

Module	Test Point No.	Signal Name
A1		
Low Voltage		
Power Supply		
A1A1	101	Pulse Width Mod Out
	102	Pulse Width Mod Dr
	103	HV Source Voltage
A1A2	201	Ground
	202	+5V FB
	203	-5V
	204	+12V
	205	-12V
	206	+33V
	207	+110V
	208	-110V
A1A3		
Control Board	301	+8V
	302	PWM Dr
	303	Error Voltage
	304	H.V. Bias Supply Voltage
	305	Sawtooth Voltage
	306	Chopper DR A
	307	Chopper DR B
A1A4		
Relay Assembly	401	Batt Chg
	402	Frequency Std Sup Voltage
	403	Relay +12V
	404	Dc Bus
A2		
Scope Amplifier	1	Int Horiz Input
	2	Horizontal Deflection Plate
	3	Horizontal Deflection Plate
	4	Vertical Drive
	5	Focus TV
	6	Vertical Deflection Plate
	7	Vertical Deflection Plate
	8	CRT Z-Axis



Table 5-7. Test Point Identification (Cont)

Module	Test Point No.	Signal Name
	9	Intensity TV
	10	Time Base Output
A3		
Scope/DVM Control	1	Vertical Character Sync
	2	Ext DVM to A/D
	3	+15V
	4	Positive Peak Detector
	5	Int. DVM to A/D
	6	Negative Peak Detector
	7	Carrier + MOD Level
	8	Character Gen. Reset
	9	GND
	10	GND
	11	+8V
	12	-8V
A6		
Audio Synthesizer	1	Synth DPL Audio
	2	DPL Clock
	3	Unfiltered DPL
	4	Synth. D/A Output
	5	Ground
	6	Composite Modulation Audio
	7	Composite External Mod. Audio
	8	Synthesizer Clock 104.857.6 Hz
	9	1 kHz Modulation Source
A7		
Processor I/O	1	A/D Input
	2	Unfiltered 10.245 MHz T.V.
	3	DVM/Freq. Counter Select
	4	Frequency Counter Input
	5	Not Used
A9		
Processor	1	Ground
	2	Dot Clock
	3	Character Row Clock
	4	Character Clock
	5	Enable
	6	Character Line Clock
	7	R/W Select
	8	Char. Gen/Processor Select
A12		
Front Panel Interface	1	Attenuator Buffer Output

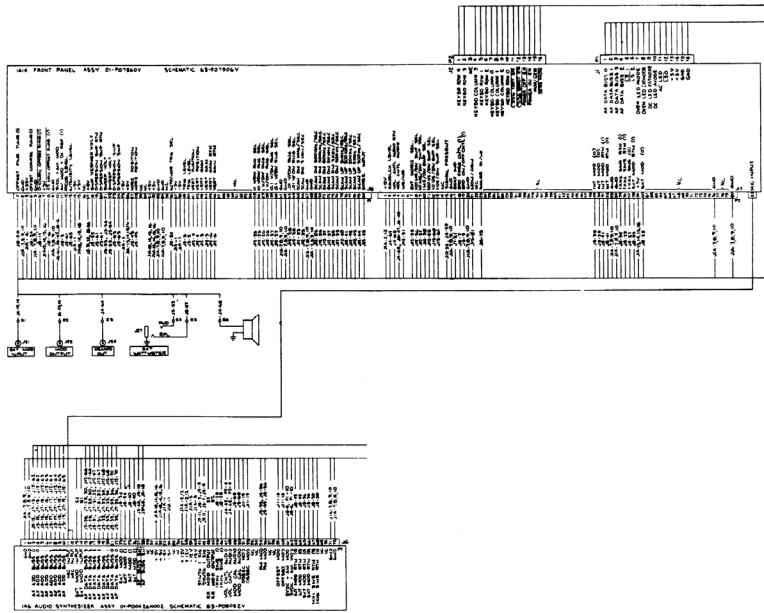

Figure 6-1. Communications System Analyzer Interconnection Diagram (Sheet 1 of 4)

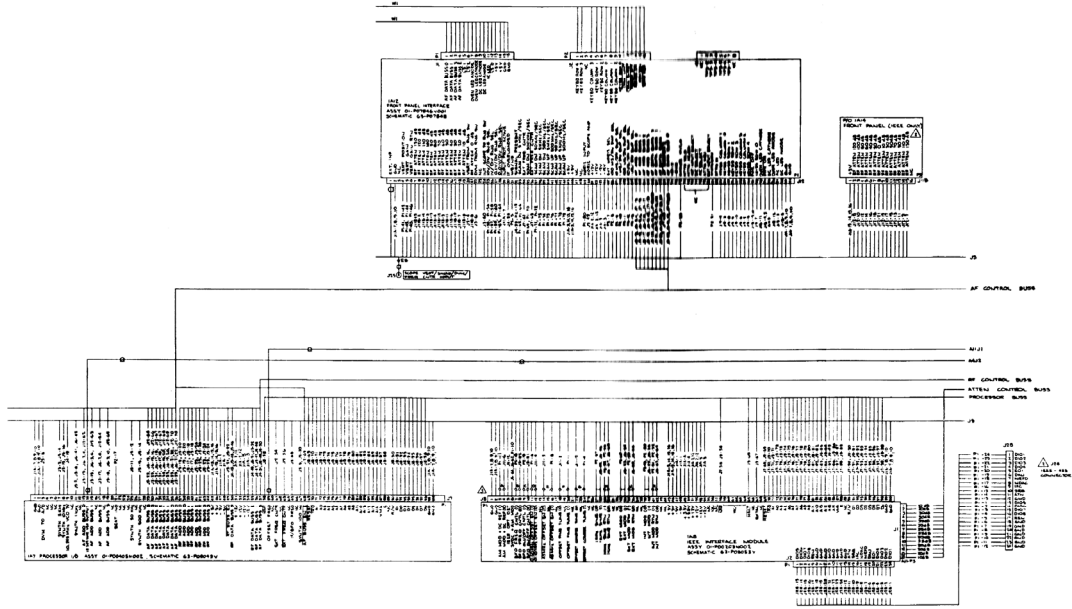

Figure 6-1. Communications System Analyzer Interconnection Diagram (Sheet 2 of 4)

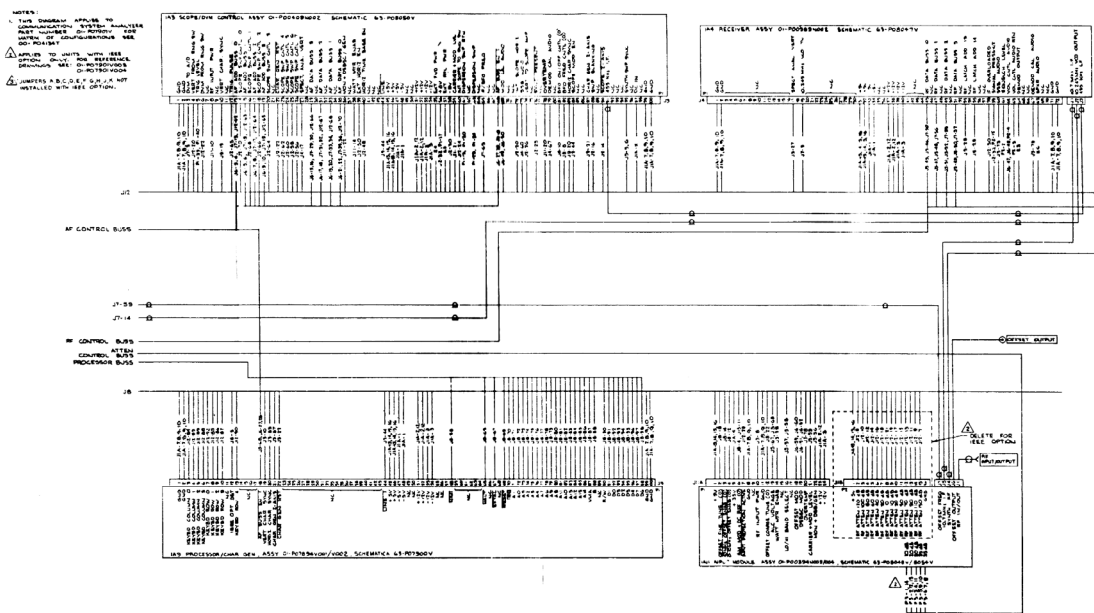

Figure 6-1. Communications System Analyzer Interconnection Diagram (Sheet 3 of 4)

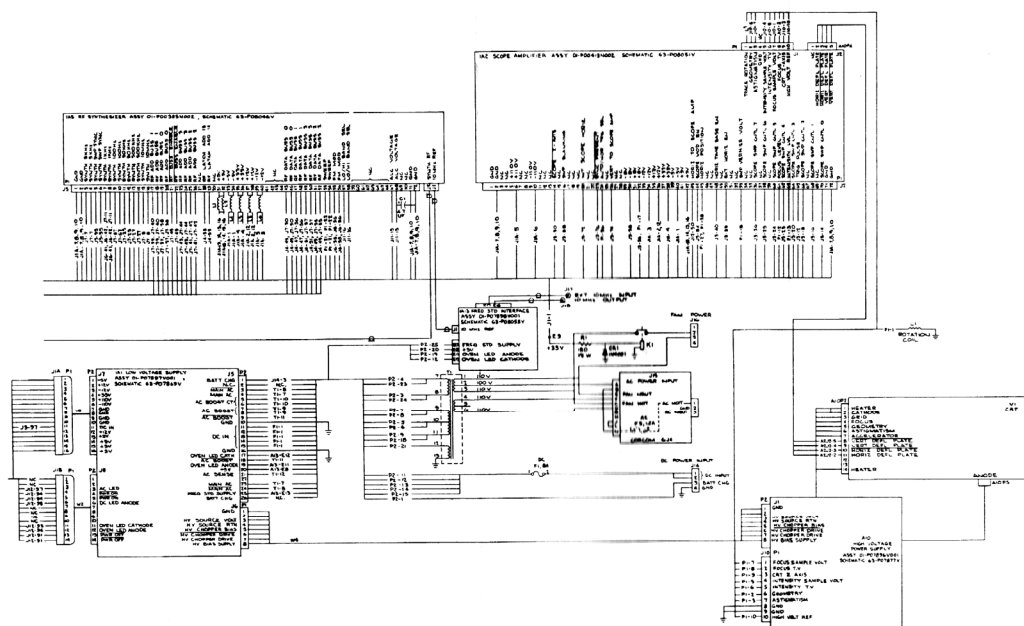

Figure 6-1. Communications System Analyzer Interconnection Diagram (Sheet 4 of 4)

Find No.	Qty. Req.	Part No.	Nomenclature	Part Value
001	1	84-80295417	MOTHERBOARD	
002	AR	848246893	SOLDER*	
003	AR	1114187421	RES	BLACK
004	1	09-80331488	SOCKET SOLDER DIP	14 PIN
005	2	09-80331487	SOCKET SOLDER DIP	18 PIN
006	1	09-80331488	SOCKET SOLDER DIP	24 PIN
007	AR	09-80331488	WIRE	#24 WHIT
C 001	1	3208411919	CAPAC TOR	47UF-20-50
J 002	1	09-80395483	CONNECTOR	
J 004	1	09-80395482	CONNECTOR	
J 005	1	09-80395482	CONNECTOR	
J 006	1	09-80395482	CONNECTOR	
J 007	1	09-80395483	CONNECTOR	
J 008	1	09-80395483	CONNECTOR	
J 009	1	09-80395483	CONNECTOR	
J 012	1	09-80395483	CONNECTOR	
L 001	1	25-80127001	CHIME AUDIO	
L 002	1	25-80127001	CHIME AUDIO	
L 003	1	25-80127001	CHIME AUDIO	
L 004	1	24-80364834	COIL	47UH
L 005	1	24-80364833	COIL	470UH
L 006	1	24-80364835	COIL	100UH

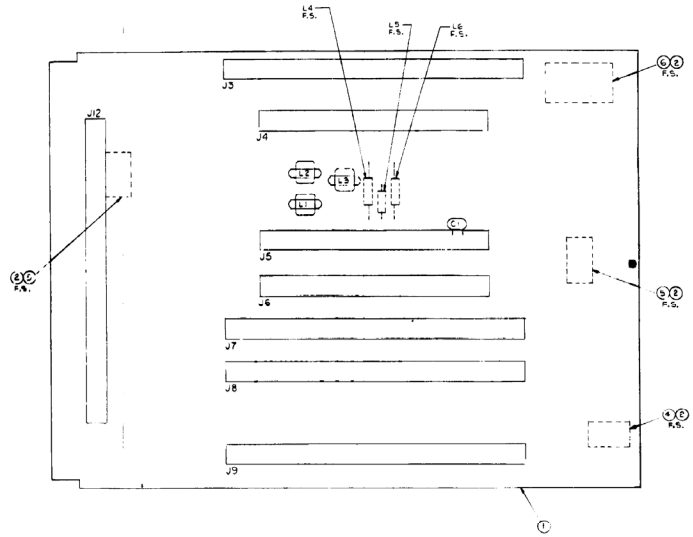
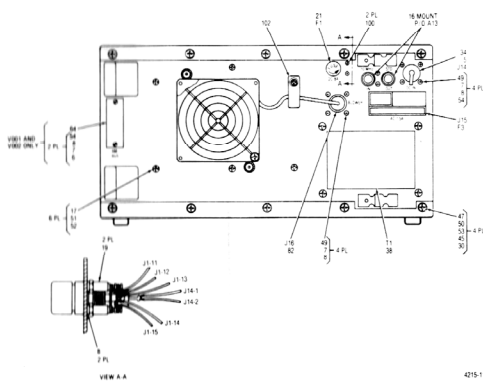
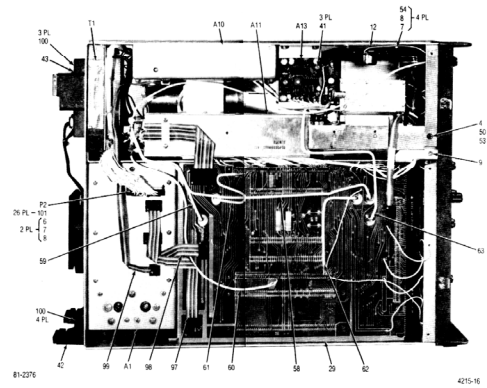

Figure 6-2. Motherboard Assembly RTL-4089A
Parts Location Diagram



Communications System Analyzer, Rear Panel



Communications System Analyzer, Bottom View

Figure 6-3. Communications System Analyzer
Parts Location Diagram
(Sheet 1 of 3)

Find No.	Qty. Req.	Part No.	Nomenclature	Part Usage
001	1	07-4029151001	BRACKET MOUNTING B	
002	2	28-10101430	TERMINAL STUD TERN	
003	1	M372725.1	TERMINAL	
004	AR	SME2011A1A1P2	SOLDER	
005	AR		WIRE	#22 WHT
006	AR	11-14187A01	WIK	BLADE
007	2	M353026.219	SCREW/PH	4-40# 219
008	2	04-114983	WASHER LOCK	118
009	2	M327183.4	WASHER PLAT	NG4
010	2	N48271.4	NUT HELICOPT	4-40
011	AR		WIRE	#22
012	AR		INSULATION SLEEVE	#22 WHT TFP
CR001	1	48-88650C47	DIODE	
K.001	1	80-80370455	RELAY	
R.001	1	06-124331	RESISTOR	100 Ω ±1%

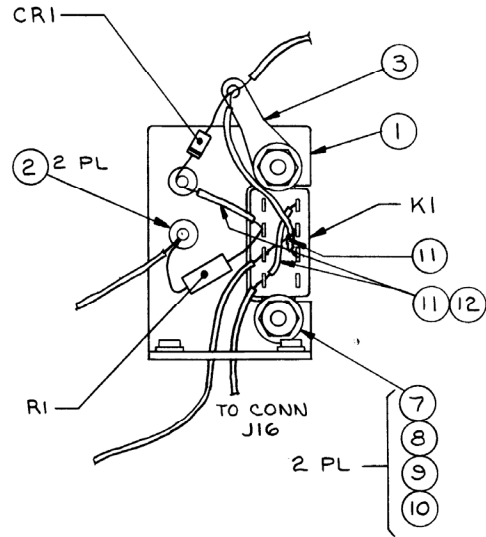

1-80305A54
Figure 6-4. Blower Relay Assembly
Parts Location Diagram

SECTION 7

LOW VOLTAGE POWER SUPPLY (A1)

7-1. GENERAL. The low voltage power supply (figure 7-1) converts an AC line voltage input or a DC voltage input to the required DC operating voltages. The power supply is composed of four modules, each module containing a printed wiring board. These modules are the relay, control, switcher, and output modules. Protection circuits protect the power supply against short circuits, high internal temperatures, and high and low DC bus voltages.

7-2. INPUT POWER CONTROL. When AC power is applied to the power supply, the output of the AC rectifier and filter circuit provides the DC bus voltage. An AC sense circuit provides a control voltage when AC power is present. This control voltage isolates the DC voltage input from the DC bus and drives the front panel AC indicator.

7-3. The off, standby, or on operating mode of the power supply is selected by the control circuit. When the analyzer is off, the frequency standard and chopper generator are off, and the battery charger is on. When the analyzer is in standby, the chopper generator is off and the frequency standard and battery charger are on. When the analyzer is on, the frequency standard and chopper generator are on and the battery charger is off. Thus, the battery is charged when the analyzer is in the off and standby modes of operation. The frequency standard operates in the standby and on modes of operation.

7-4. The battery charger requires a voltage higher than the nominal DC bus voltage. This increased voltage, 32V, is provided by the AC boost circuit.

7-5. To operate the power supply using a DC voltage input, the AC power input must be removed, disabling the AC sense voltage. When the AC power is removed and the analyzer turned off, no power is present on the DC bus. When the analyzer is switched to the standby mode, the DC relay closes, connecting the DC voltage input to the DC bus and the supply voltage to the frequency standard. When the analyzer is switched on, the chopper generator is enabled and normal operation occurs.

7-6. DC OUTPUT CONTROL. Regulation of the DC output voltages is accomplished by using the +5-volt output as feedback. This feedback voltage is compared to a stable reference voltage (7.9V). The resultant control voltage determines the on time of the pulse width modulator, thus regulating the input voltage to the chopper circuits. The output transformer winding ratios determine the output voltages with respect to the +5-volt feedback.

7-7. The chopper generator provides a 7-volt reference voltage, a 20-kHz squarewave chopper drive signal, and a 20 kHz triangular waveform. The pulse width modulator has a 50 percent duty cycle. For control voltages that are above or below the mean DC voltage of the triangular waveform, the duty cycle is proportionately increased or decreased.

7-8. The filtered DC output from the pulse width modulator is chopped 50 percent through the primary windings of output transformer T2 at a 20 kHz rate. The DC output is alternately switched between each half of the primary winding of T2. Current through the primary winding center tap is passed through a current transformer whose output is used for overcurrent protection.

7-9. PROTECTION CIRCUIT. This power supply is protected from shorted outputs, high internal temperatures, and high or low DC bus voltage. In each case, the protection circuit pulls the control voltage line low, disabling the pulse width modulator and shutting down the power supply outputs.

10. Short circuit protection is provided by monitoring the current in the primary winding of the output transformer. When an output is shorted, the primary winding current will increase significantly. This causes the overcurrent detector to pull the control voltage line low, disabling the pulse width modulator and shutting down the output. With the output shut down, there is no primary winding current, causing the control voltage line to be released. When the input voltage line is released, the pulse width modulator is again enabled and the power supply outputs are available again. If the short circuit is still present, the shutdown sequence will be repeated. A delay is provided in the overcurrent detector causing the shutdown sequence to cycle at an approximately 0.5 second rate.
11. Over temperature protection is provided by a thermal switch. When the temperature of the power supply exceeds the setting of the thermal switch, the switch closes, pulling the control voltage line low, disabling the pulse width modulator and shutting down the power supply outputs. Normal power supply operation will resume when the temperature returns to a safe operating level.
12. Protection against high or low DC or AC line inputs is provided by monitoring the DC bus voltage. When the DC bus voltage exceeds 20 volts, or falls below 10 volts, the high/low shutdown circuit pulls the control voltage line low, disabling the pulse width modulator and shutting down the power supply outputs. When the DC bus voltage returns to normal, the power supply will automatically resume normal operation.
13. **HIGH VOLTAGE CONTROL.** The HV BIAS V line and the HV SOURCE V line provide the high voltage power supply A10 with bias voltage and primary power, respectively.
14. **SWITCHER MODULE A1A1.** The switcher module (figure 7-4) contains the pulse width modulator and upper circuits. The input PWM DRIVE signal, from the control module, switches the chopping circuit on and off, producing a rectangular wave output which is filtered and applied to transformer choppers A and B. In effect, this signal regulates the voltage which is applied to transformer T201 on the output module. The PWM OUT signal is a secondary input to the voltage regulator/comparator on the control module.
15. Transformer choppers A and B are driven by CHOPPER DR A and CHOPPER DR B signals from the control module. Output signals XFMR DR A and XFMR DR B are 180-degree out-of-phase and XFMR DR A and XFMR DR B are 180-degree out-of-phase. An output, HV SOURCE V, from the chopping circuit is the primary power source for the high voltage power supply.
16. **OVP (Overvoltage Protection).** The OVP zener is connected to the +5V output from the output module and meets the maximum +5 volt level to +6.3 volts.
17. **OUTPUT MODULE A1A2.** The output module (figure 7-8) provides the regulated output voltages and the current sense voltage for the overcurrent protection circuit. Input power is provided by signals XFMR DR A, A', B and B'. These signals are 20 kHz squarewaves and drive the primary windings of transformer T201. After full wave rectification and filtering, the nominal output voltages are available as shown in figure 7-8.
18. The primary current of transformer T201 is monitored by transformer T202. The voltage developed across T202 is full wave rectified and applied to the current limit circuit on the control module by the CURRENT LIMIT SENSE signal. An increase in the primary current of T201 produces a corresponding increase in the voltage developed across T202. This increase is applied to the current limit circuit and overcurrent protection is initiated.
19. Regulation of the output voltage is accomplished by the +5-volt feedback. When the +5-volt output is regulated, the remaining output voltages will be regulated because of the turns ratio of the windings between the outputs. When the +5-volt output is held to one percent regulation, the other outputs will be held to five percent regulation.
20. The OVP (Overvoltage Protection) output is applied to a 6.2-volt zener diode mounted on the chopper assembly that provides overvoltage protection to the +5-volt output.

7-2



7-21. **CONTROL MODULE A1A3.** The control module (figure 7-11) provides pulse width modulation control and contains the protection circuits. Pulse width modulation control is accomplished by comparing a 7.9V reference voltage to the +5-volt feedback from the output module. The resultant integrated control voltage is applied to the pulse width control. This voltage is compared to the 20 kHz triangle voltage to determine the duty cycle of the pulse width modulator. The chopper drive outputs are squarewaves and are 180-degree out-of-phase with each other.

7-22. When the DC BUS voltage is over 20 or under 10 volts DC, the over/under voltage protection circuit pulls the control voltage signal to the pulsewidth control circuit low. This action shuts down the pulsewidth modulator.

7-23. The soft start circuit slows the rise time of the control signal to the pulsewidth control circuits. When the signal reaches the operating level the soft start circuit is switched out of the control loop.

7-24. The overcurrent detector compares a signal that is proportioned to the current in the current transformer, to a reference. When the current is too high, the control signal is pulled low, shutting down the output module. After a delay, the output module operates again, if the malfunction causing the overcurrent is still present, the module will shut down again. This sequence will cycle at a 0.5 second rate until the malfunction is corrected.

7-25. When the internal temperature of the power supply rises above 85°C, the overtemp shutdown circuit causes the control signal to go low, shutting down the pulsewidth control circuit. The control logic functions are shown in table 7-1.

Table 7-1. Control Logic Functions

Input Signals		Output Signals				
Pwr On	AC Sense	Batt Chr Enable	HV Bias Supply V	AC Led	DC Led Anode	Relay Enable*
Low	Low	High	On	Off	On	Low
High	High	Low	On	On	Off	High
Low	Low	Low	Off	Off	Off	Low
High	High	High	Off	On	On	High

*Note that RELAY ENABLE low, does not imply that the relay is closed. The PWR OFF signal on the relay module must also be high to close the relay.

7-26. **RELAY MODULE A1A4.** The relay module (figure 7-14) is mounted on one end plate of the power supply. Primary power is applied to the module through a line transformer or the DC input. When an AC input is used, the RELAY ENABLE line is high, the relay is open, and the power supply operates from the AC input. The MAIN AC and MAIN AC lines receive a 13.5-volt AC rms input from the line transformer. After full wave rectification, the DC power is routed throughout the power supply on the DC bus. Filtering of the DC power is done on the switcher module.

7-27. When the DC input is used, the RELAY ENABLE line is low, the relay is closed, and the power supply operates from the DC input. The battery charge voltage is boosted to 32 volts using the AC bus voltage to bias an AC boost winding center top.

7-3

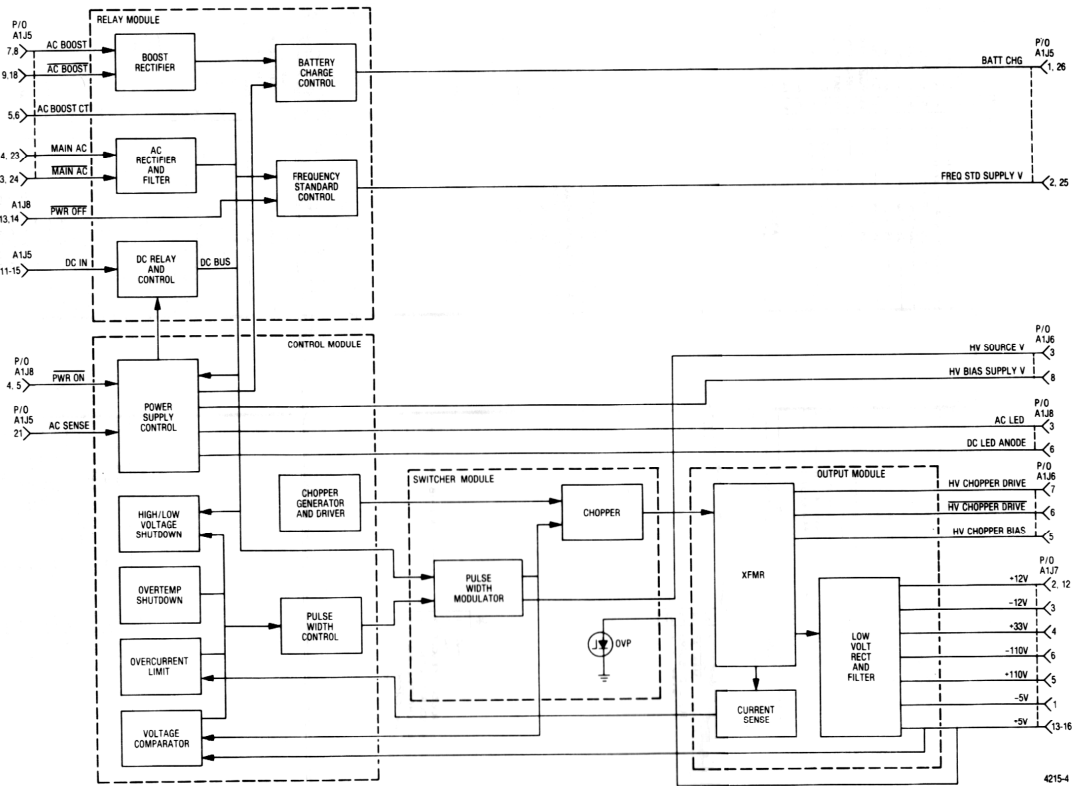

Figure 7-1. Low-Voltage Power Supply A1 Block Diagram

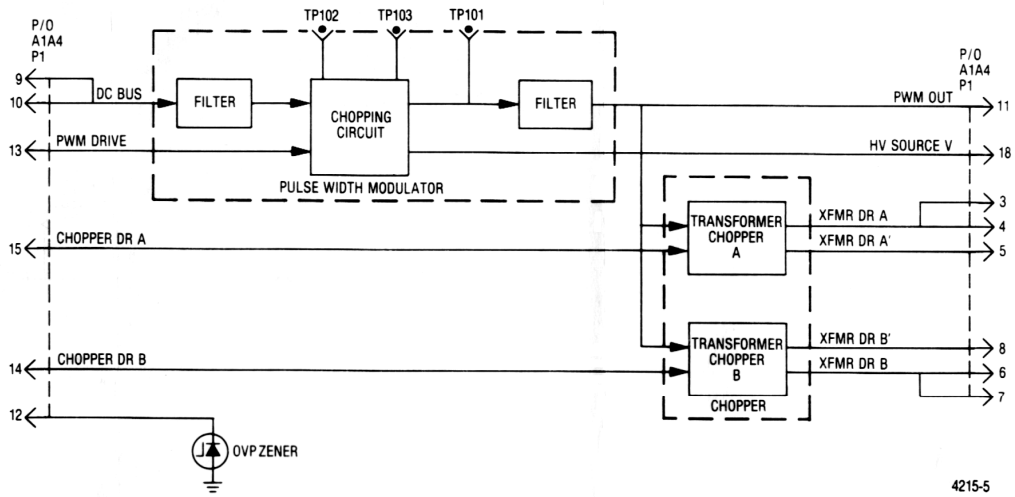

Figure 7-4. Low Voltage Power Supply Switcher Module A1A1 Block Diagram

- NOTES:
- PARTIAL REFERENCE DESIGNATIONS ARE SHOWN FOR COMPLETE DESIGNATION REFER WITH A1.
 - FOR REFERENCE DRAWINGS REFER TO: Q1-Q078BY SWITCHER ASSY Q1-Q078CB SWITCHER PWR ASSY
 - UNLESS OTHERWISE SPECIFIED: ALL RESISTORS ARE IN OHMS; ALL CAPACITORS ARE IN UF; ALL INDUCTORS ARE IN MH; ALL VOLTAGES ARE DC.
 - W COMPONENTS MOUNTED TO PLATE SWITCH MOUNTING.

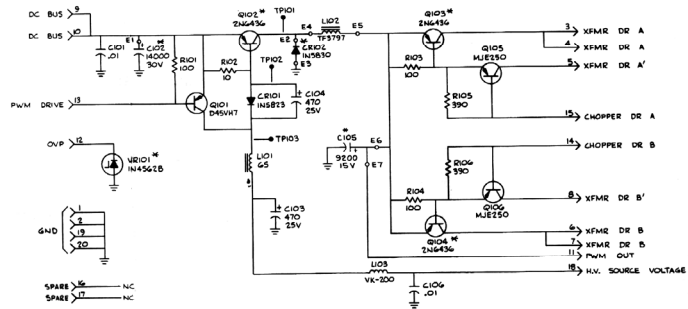

Figure 7-5. Low Voltage Power Supply Switcher Module A1A1 Schematic Diagram

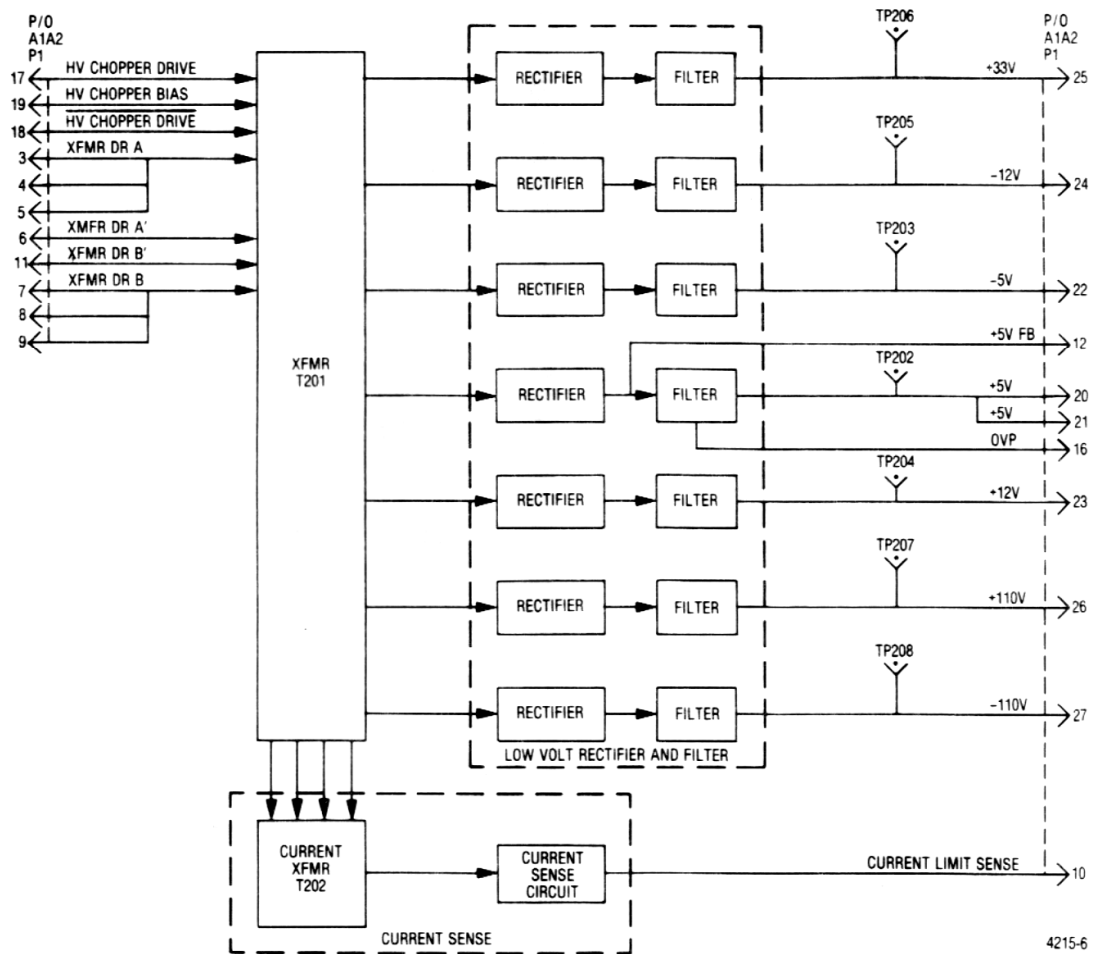

Figure 7-8. Low Voltage Power Supply Output Module A1A2 Block Diagram

- NOTES
- PARTIAL REFERENCE DESIGNATIONS ARE SHOWN. FOR COMPLETE DESIGNATION PREFIX WITH A1.
 - FOR REFERENCE DRAWINGS REFER TO: 011 ROTARY OUTPUT PWB ASSY
 - UNLESS OTHERWISE SPECIFIED:
 ALL RESISTORS ARE IN OHMS,
 IS NOT (1/4WATT),
 ALL CAPACITORS ARE IN PPF,
 ALL DIMENSIONS ARE IN INCH,
 ALL VOLTAGES ARE DC.
-  MOTOROLA P/N 24-P08041Y001
 MOTOROLA P/N 24-P08041Y001
 MOTOROLA P/N 24-P08041Y001

RES DESIGNATIONS	
USED	NOT USED
C124	
C121B	
L100	
R108	
T202	
TP208	

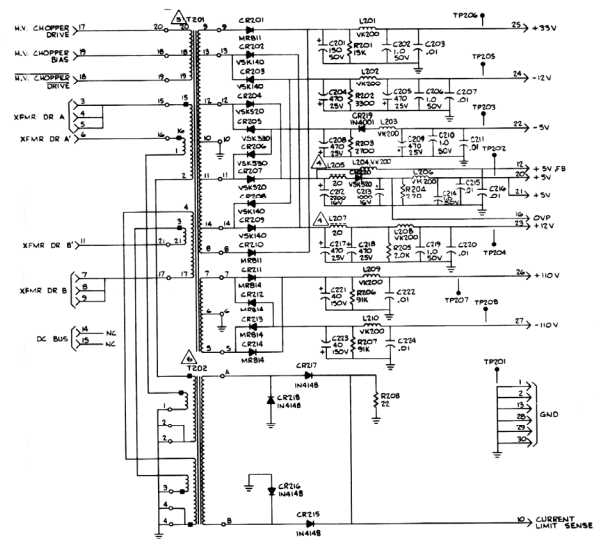

Figure 7-9. Low Voltage Power Supply Output Module A1A2 Schematic Diagram

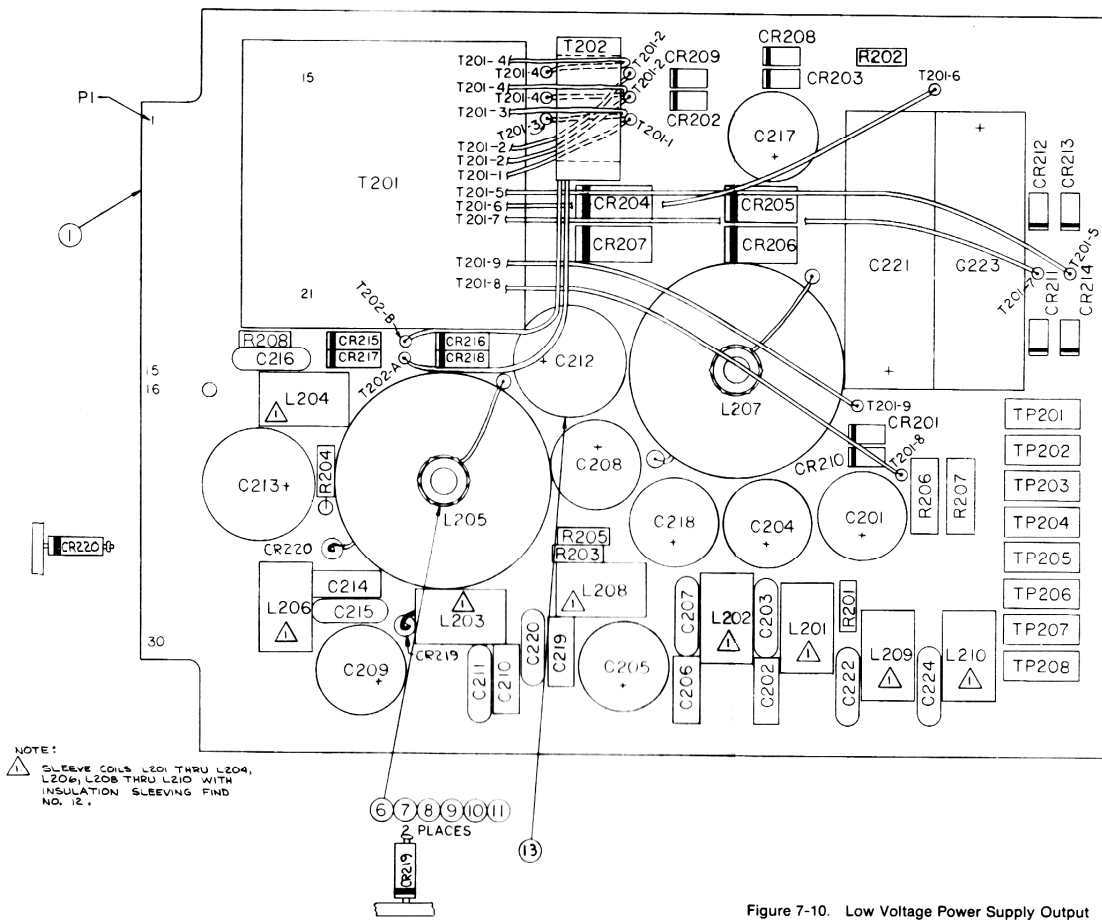
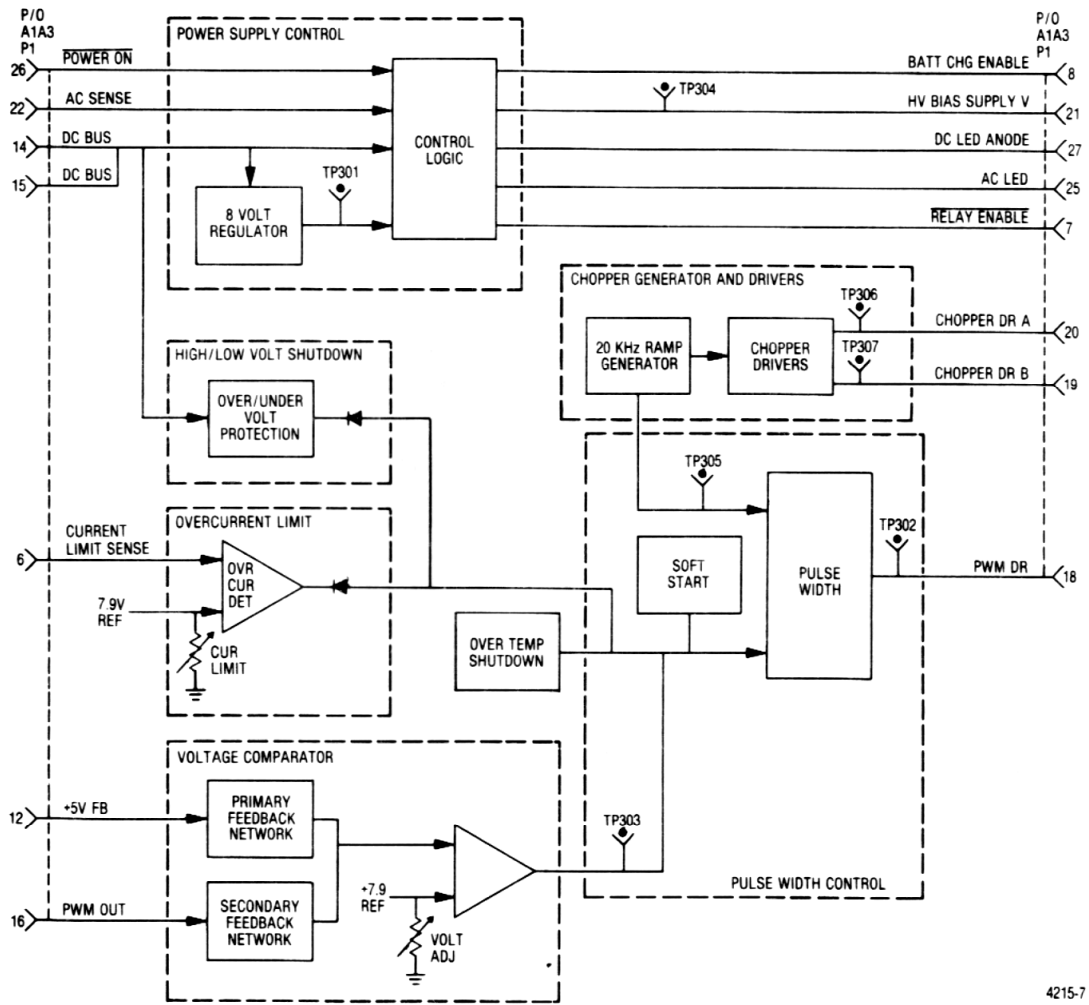

Figure 7-10. Low Voltage Power Supply Output Module A1A2 (RTP-4013A) Parts Location Diagram (Sheet 1 of 2)

Figure 7-10. Low Voltage Power Supply Output Module A1A2 (RTP-4013A) Parts Location Diagram (Sheet 2 of 2)

Find No.	Qty. Req.	Part No.	Nomenclature	Part Value	Find No.	Qty. Req.	Part No.	Nomenclature	Part Value
001	1	84-PW7871001	PRINTED WIRING BOA		CR219	1	48-8035417	DIODE	
003	AR	5848WPS	SOLDER		CR220	1	48-8034487	DIODE	20V-5A
004	AR	11-14187A01	INK	BLACK	L201	1	24-8028846	COIL	
005	2	5807	WASHER-FLY	158	L202	1	24-8028846	COIL	
007	2	M83326-232	SCREW-PH	1380-32X 750	L203	1	24-8028846	COIL	
008	2	M83338-41	WASHER-LOCK	138	L204	1	24-8028846	COIL	
009	2	M82718-6	WASHER-FLY	158	L205	1	24-8028846	COIL	200H
010	2	M33948-282	NUT-HEX	1380-32	L206	1	24-8028846	COIL	
011	2	14-15-0044	INSULATOR-INDUCTOR		L207	1	24-8028846	COIL	200H-1/4
012	AR	M29235-208-C	INSULATION SLEEVE	250 CLR	L208	1	24-8028846	COIL	200H
013	1	5612-81-31	WASHER-TENSION		L209	1	24-8028846	COIL	
C 201	1	23-8028845	CAPACITOR	100UF-50V	L210	1	24-8028846	COIL	
C 202	1	20325U1822000	CAPACITOR	1UF-20 + 80-50	R 201	1	68124178	RESISTOR	13K-5-1/4
C 203	1	21-8028842	CAPACITOR	21UF-20 + 80-200	R 202	1	68124411	RESISTOR	3.3K-5-1/4
C 204	1	23-8028844	CAPACITOR	470UF-25V	R 203	1	68124458	RESISTOR	2.7K-5-1/4
C 205	1	23-8028844	CAPACITOR	470UF-25V	R 204	1	68124435	RESISTOR	270-5-1/4
C 206	1	20325U1822000	CAPACITOR	1UF-20 + 80-50	R 205	1	68124466	RESISTOR	230K-5-1/4
C 207	1	21-8028842	CAPACITOR	21UF-20 + 80-200	R 206	1	68124466	RESISTOR	81K-5-1/2
C 208	1	23-8028844	CAPACITOR	470UF-25V	R 207	1	68124466	RESISTOR	81K-5-1/2
C 209	1	23-8028844	CAPACITOR	470UF-25V	R 208	1	68124466	RESISTOR	25.5-1/4
C 210	1	20325U1822000	CAPACITOR	1UF-20 + 80-50	T 201	1	25-80358A12	TRANSFORMER	
C 211	1	21-8028842	CAPACITOR	21UF-20 + 80-200	T 202	1	24-8028846	TRANSFORMER	
C 212	1	23-8028845	CAPACITOR	2000UF-15V	TP201	1	08-80371AB8	JACK-TIP	WHIT
C 213	1	23-8028842	CAPACITOR	1000UF-15V	TP202	1	08-80371AB8	JACK-TIP	WHIT
C 214	1	20325U1822000	CAPACITOR	1UF-20 + 80-50	TP203	1	08-80371AB8	JACK-TIP	WHIT
C 215	1	21-8028842	CAPACITOR	21UF-20 + 80-200	TP204	1	08-80371AB8	JACK-TIP	WHIT
C 216	1	21-8028842	CAPACITOR	21UF-20 + 80-200	TP205	1	08-80371AB8	JACK-TIP	WHIT
C 217	1	23-8028844	CAPACITOR	470UF-25V	TP206	1	08-80371AB8	JACK-TIP	WHIT
C 218	1	23-8028844	CAPACITOR	470UF-25V	TP207	1	08-80371AB8	JACK-TIP	WHIT
C 219	1	20325U1822000	CAPACITOR	1UF-20 + 80-50	TP208	1	08-80371AB8	JACK-TIP	WHIT
C 220	1	21-8028842	CAPACITOR	21UF-20 + 80-200					
C 221	1	23-8028847	CAPACITOR	40UF-150V					
C 222	1	21-8028842	CAPACITOR	21UF-20 + 80-200					
F 201	1	5L3086A49	FAN-CYCLE	40UF-16A					
G 201	1	21-8028842	CAPACITOR	21UF-20 + 80-200					
CR201	1	48-8035488	DIODE	100V-1A					
CR202	1	48-8035488	DIODE	40V-1A					
CR203	1	48-8035488	DIODE	40V-1A					
CR204	1	48-8035487	DIODE	20V-5A					
CR205	1	48-8035484	DIODE	30V-3A					
CR206	1	48-8035484	DIODE	20V-5A					
CR207	1	48-8035487	DIODE	20V-5A					
CR208	1	48-8035488	DIODE	40V-1A					
CR209	1	48-8035488	DIODE	40V-1A					
CR210	1	48-8035488	DIODE	100V-1A					
CR211	1	48-8035470	DIODE	40V-1A					
CR212	1	48-8035470	DIODE	40V-1A					
CR213	1	48-8035470	DIODE	40V-1A					
CR214	1	48-8035470	DIODE	40V-1A					
CR215	1	48-8443302	DIODE						
CR216	1	48-8443302	DIODE						
CR217	1	48-8443302	DIODE						
CR218	1	48-8443302	DIODE						



4215-7

Figure 7-11. Low-Voltage Power Supply Control Module A1A3 Block Diagram

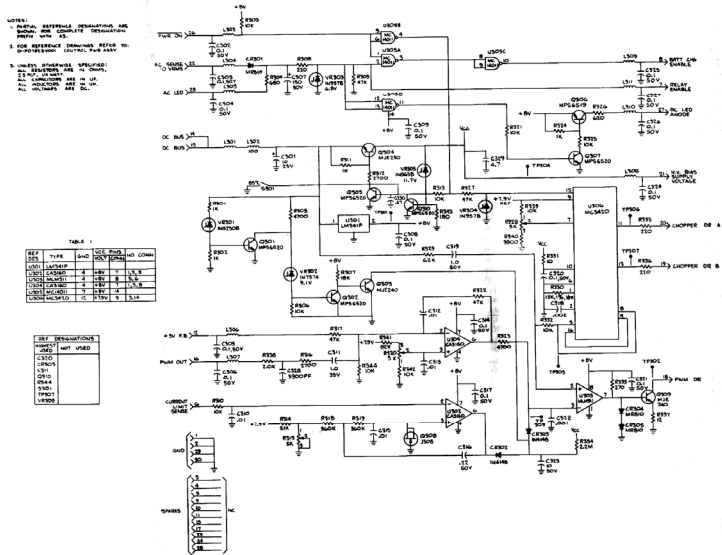

Figure 7-12. Low Voltage Power Supply Control Module A1A3 Schematic Diagram

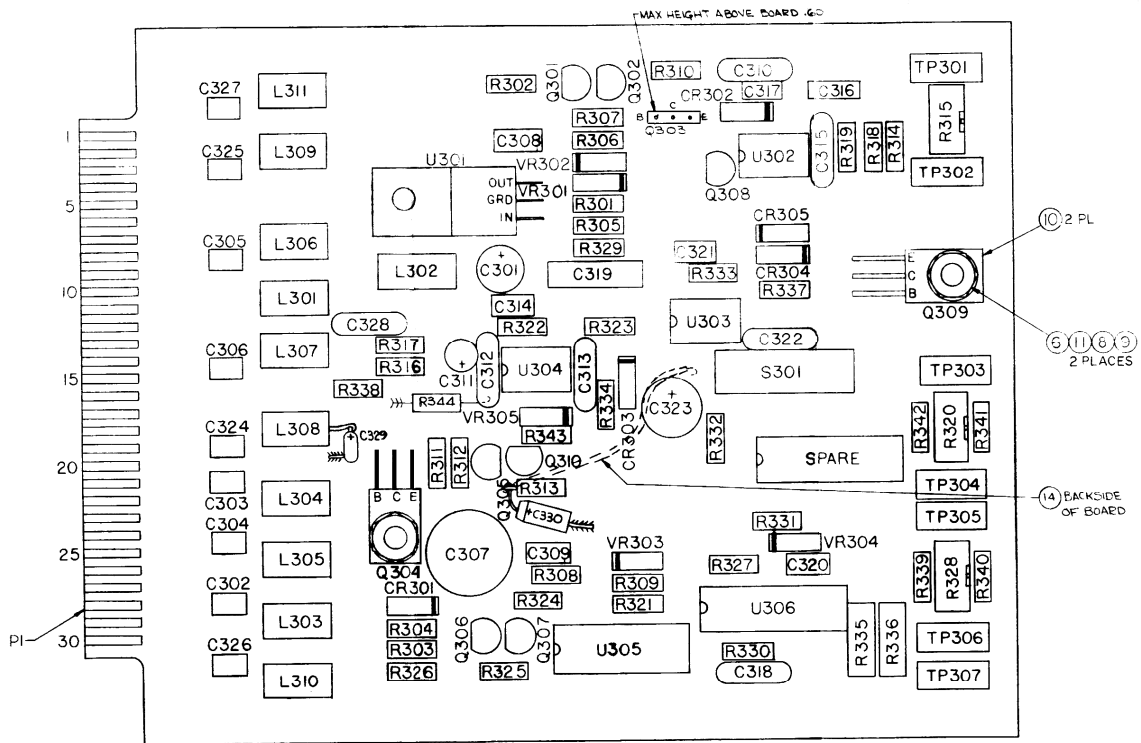
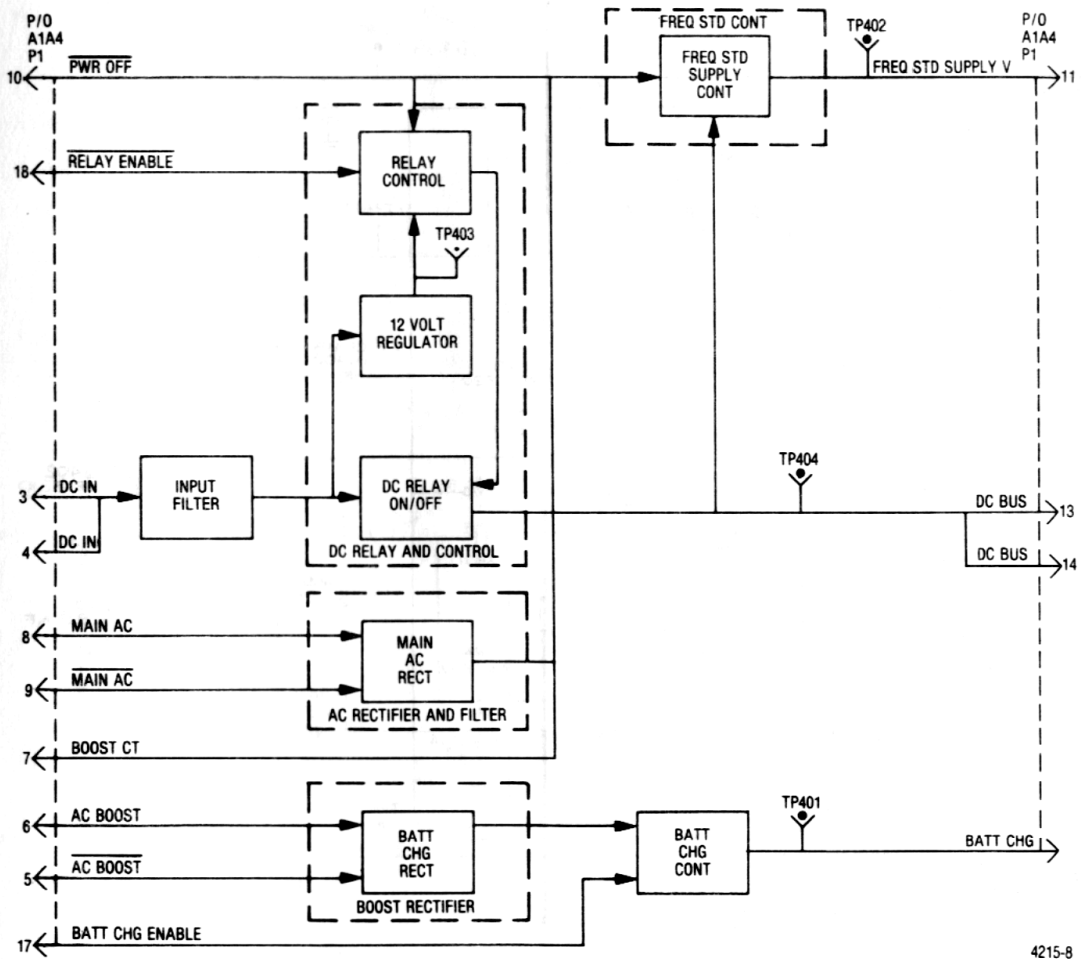

Figure 7-13. Low Voltage Power Supply Control Module A1A3 (RTP-4012A) Parts Location Diagram (Sheet 1 of 2)

Find No.	Qty Req.	Part No.	Nomenclature	Part Value	Find No.	Qty Req.	Part No.	Nomenclature	Part Value	Find No.	Qty Req.	Part No.	Nomenclature	Part Value
001	1	84-20284V001	PRINTED WIRING BOA		L 300	1	24C20611001	CHOKER.FF		R 342	1	85124A73	RESISTOR	10K 5-1/4
003	AR	540289P2	SOLDER		L 311	1	24C20611001	CHOKER.FF		R 343	1	85124A31	RESISTOR	10K 5-1/4
004	AR	11-14181A21	REL	BLACK	Q 201	1	48-8028A01	TRANSISTOR		R 344	1	85124A73	RESISTOR	10K 5-1/4
006	2	48-8028A01	SCRIBER	1129-405-500	Q 202	1	48-8028A01	TRANSISTOR		S 201	1	48-8028A02	SWITCH THERMAL	RS 1455 G
008	2	04-1143E2	WASHER LOCK	112	Q 203	1	48-8028A07	TRANSISTOR		TP201	1	09-80221A08	JACK.TYP	WHT
009	2	02-2018	NUT	1129-40	Q 204	1	48-8028A08	TRANSISTOR		TP202	1	09-80221A08	JACK.TYP	WHT
010	2	14-80221A46	INSULATOR		Q 205	1	48-8028A01	TRANSISTOR		TP203	1	09-80221A08	JACK.TYP	WHT
011	2	85220P006	WASHER COMP		Q 206	1	48-8028A02	TRANSISTOR		TP204	1	09-80221A08	JACK.TYP	WHT
014	AR	WRETSOLS	WRETSOLS	#34 WHT TEFLON	Q 207	1	48-8028A01	TRANSISTOR		TP205	1	09-80221A08	JACK.TYP	WHT
C 301	1	23-8028A40	CAPACITOR	10UF 25V	Q 208	1	48-8028A41	TRANSISTOR		TP206	1	09-80221A08	JACK.TYP	WHT
C 302	1	21-8027A31	CAPACITOR	10UF 20-50	Q 209	1	48-8028A07	TRANSISTOR		TP207	1	09-80221A08	JACK.TYP	WHT
C 303	1	21-8027A31	CAPACITOR	10UF 20-50	Q 210	1	48-8028A01	TRANSISTOR		U 201	1	11-8024A08	INTEGRATED CIRCUIT	LM311P-B SCHEM
C 304	1	21-8027A31	CAPACITOR	10UF 20-50	R 201	1	85124A49	RESISTOR	1K 5-1/4	U 202	1	11-8024A02	INTEGRATED CIRCUIT	CAS918E SCHEM
C 305	1	21-8027A31	CAPACITOR	10UF 20-50	R 202	1	85124A48	RESISTOR	1K 5-1/4	U 203	1	11-8024A08	INTEGRATED CIRCUIT	LM311P SCHEM
C 306	1	21-8027A31	CAPACITOR	10UF 20-50	R 203	1	85124A73	RESISTOR	10K 5-1/4	U 204	1	11-8024A02	INTEGRATED CIRCUIT	CAS918E SCHEM
C 307	1	23-8028A73	CAPACITOR	150UF 50V	R 204	1	85124A45	RESISTOR	47K 5-1/4	U 205	1	11-8024A04	INTEGRATED CIRCUIT	MC2302P SCHEM
C 308	1	21-8027A31	CAPACITOR	10UF 20-50	R 205	1	85124A55	RESISTOR	10K 5-1/4	U 206	1	11-8024A02	INTEGRATED CIRCUIT	MC2302P SCHEM
C 309	1	21-8027A31	CAPACITOR	10UF 20-50	R 206	1	85124A73	RESISTOR	10K 5-1/4	V201	1	48-8028C05	DIODE ZENER	20V 5-S
C 310	1	21-8028A32	CAPACITOR	01UF 50V 80-200	R 207	1	85124A79	RESISTOR	10K 5-1/4	V202	1	48-8028C04	DIODE ZENER	8.2V
C 311	1	2302841 018	CAPACITOR	1.0UF 20-35	R 208	1	85124A33	RESISTOR	25K 5-1/4	V203	1	48-811408	DIODE ZENER	8.2V
C 312	1	21-8028A32	CAPACITOR	01UF 20V 80-200	R 209	1	85124A29	RESISTOR	47K 5-1/4	V204	1	48-811409	DIODE ZENER	8.2V
C 313	1	21-8028A32	CAPACITOR	01UF 20V 80-200	R 210	1	85124A73	RESISTOR	10K 5-1/4	V205	1	48-8028C25	DIODE ZENER	12V 0-10
C 314	1	21-8027A31	CAPACITOR	10UF 20-50	R 211	1	85124A49	RESISTOR	1K 5-1/4					
C 315	1	21-8028A32	CAPACITOR	01UF 20V 80-200	R 212	1	85124A39	RESISTOR	10K 5-1/4					
C 316	1	21-8027A06	CAPACITOR	22UF 10-50	R 213	1	85124A73	RESISTOR	2.7K 5-1/4					
C 317	1	21-8027A31	CAPACITOR	10UF 20-50	R 214	1	85124A09	RESISTOR	57K 5-1/4					
C 318	1	21028280208	CAPACITOR	800UF 10-20	R 215	1	85124A09	RESISTOR	47K 5-1/4					
C 319	1	3C21706102-0060	CAPACITOR	10UF 35V 80-50	R 216	1	85124A09	RESISTOR	300K 5-1/4					
C 320	1	21-8027A31	CAPACITOR	10UF 20-50	R 217	1	85124A09	RESISTOR	300K 5-1/4					
C 321	1	21-8027A31	CAPACITOR	10UF 20-50	R 218	1	85124A09	RESISTOR	300K 5-1/4					
C 322	1	21-8028A32	CAPACITOR	1000PF 10-100	R 219	1	85124A11	RESISTOR	300K 5-1/4					
C 323	1	09-8028A72	CAPACITOR	10UF 20-50	R 220	1	85124A09	RESISTOR	10K 5-1/4					
C 324	1	21-8027A31	CAPACITOR	10UF 20-50	R 221	1	85124A73	RESISTOR	10K 5-1/4					
C 325	1	21-8027A31	CAPACITOR	10UF 20-50	R 222	1	85124A09	RESISTOR	47K 5-1/4					
C 326	1	21-8027A31	CAPACITOR	10UF 20-50	R 223	1	85124A09	RESISTOR	4.7K 5-1/4					
C 327	1	21-8027A31	CAPACITOR	10UF 20-50	R 224	1	85124A48	RESISTOR	1K 5-1/4					
C 328	1	2102828010	CAPACITOR	3300PF 10-100	R 225	1	85124A73	RESISTOR	10K 5-1/4					
C 329	1	2302841 018	CAPACITOR	4.7UF 20-50	R 226	1	85124A44	RESISTOR	820K 5-1/4					
C 330	1	2302841 014	CAPACITOR	47UF 20-50	R 227	1	85124A48	RESISTOR	47K 5-1/4					
CR201	1	48-8044A48	DIODE	50V 1A	R 228	1	85124A09	RESISTOR	10K 5-1/4					
CR202	1	48-8448A02	DIODE		R 229	1	85124A09	RESISTOR	10K 5-1/4					
CR203	1	48-8448A02	DIODE		R 230	1	85124A09	RESISTOR	10K 5-1/4					
CR204	1	48-8044A08	DIODE	50V 1A	R 231	1	85124A09	RESISTOR	10K 5-1/4					
CR205	1	48-8044A08	DIODE	50V 1A	R 232	1	85124A73	RESISTOR	10K 5-1/4					
L 301	1	24C20611001	CHOKER.FF	180MH	R 233	1	85124A09	RESISTOR	47K 5-1/4					
L 302	1	24-8420A00	INDUCTOR		R 234	1	85124A09	RESISTOR	2.2M 5-1/4					
L 303	1	24C20611001	CHOKER.FF		R 235	1	85124A33	RESISTOR	22K 5-1/2					
L 304	1	24C20611001	CHOKER.FF		R 236	1	85124A33	RESISTOR	22K 5-1/2					
L 305	1	24C20611001	CHOKER.FF		R 237	1	85124A09	RESISTOR	12K 5-1/4					
L 306	1	24C20611001	CHOKER.FF		R 238	1	85124A06	RESISTOR	200K 5-1/4					
L 307	1	24C20611001	CHOKER.FF		R 239	1	85124A73	RESISTOR	10K 5-1/4					
L 308	1	24C20611001	CHOKER.FF		R 240	1	85124A63	RESISTOR	300K 5-1/4					
L 309	1	24C20611001	CHOKER.FF		R 241	1	85124A49	RESISTOR	82K 5-1/4					

Figure 7-13. Low Voltage Power Supply Control Module A1A3 (RTP-4012A) Parts Location Diagram (Sheet 2 of 2)



4215-8

Figure 7-14. Low Voltage Power Supply Relay Module A1A4 Block Diagram

- NOTES:
1. INITIAL REFERENCE DESIGNATIONS ARE SHOWN. FOR COMPLETE DESIGNATION REFER WITH FIG. 1.
 2. FOR REFERENCE DRAWINGS REFER TO:
 3. UNLESS OTHERWISE SPECIFIED: ALL RESISTORS ARE IN OHMS, 2.5 PCT. 1/4 WATT, ALL CAPACITORS ARE IN UF, ALL INDUCTORS ARE IN UH, ALL VOLTAGES ARE DC.

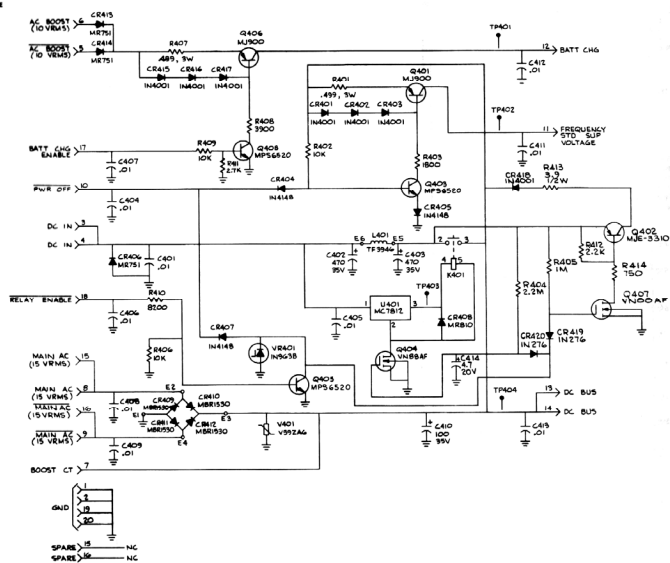

Figure 7-15. Low Voltage Power Supply Relay Module A1A4 Schematic Diagram

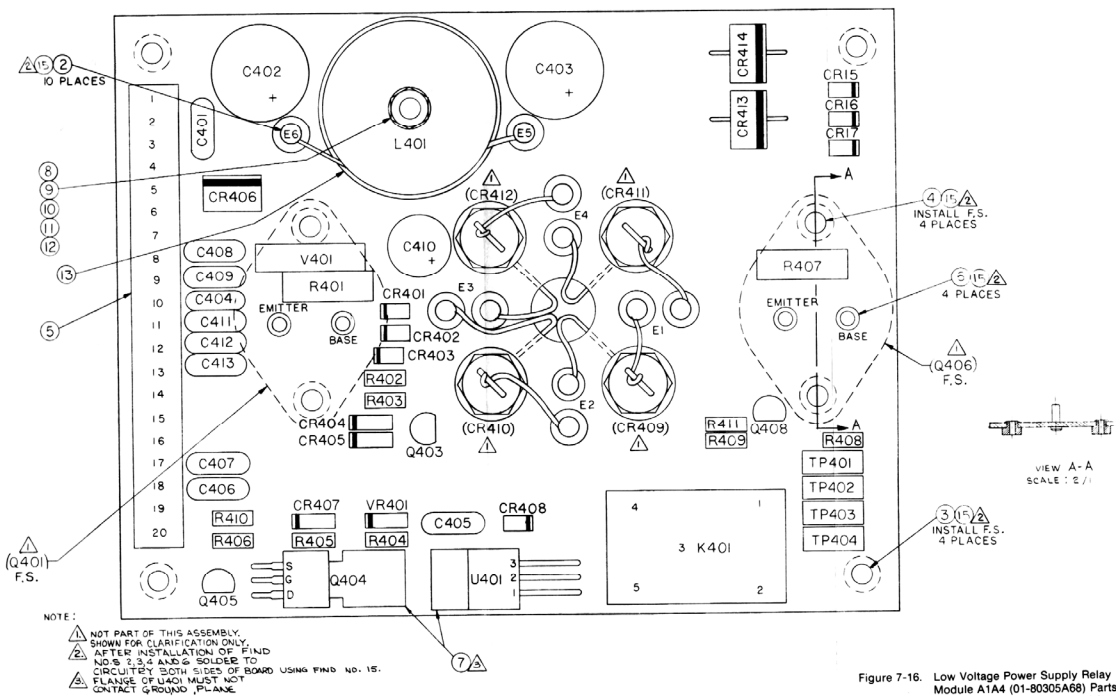
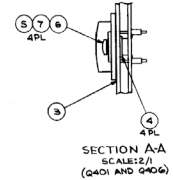

Figure 7-16. Low Voltage Power Supply Relay Module A1A4 (01-80305A68) Parts Location Diagram (Sheet 1 of 3)

Find No.	Qty. Req.	Part No.	Nomenclature	Part Value	Find No.	Qty. Req.	Part No.	Nomenclature	Part Value
001	1	84-P0786V001	PRINTED WIRING BOA		Q 408	48-80306A81	TRANSISTOR	MP5620 SCREENED	
002	10	198-17-8-20	TERMINAL		R 401	06-80270A44	RESISTOR	480-1-2	
003	4	81324-8-18-5	STANDOFF THREADED		R 402	8312473	RESISTOR	100-5-14	
004	4	8134-8-32-5	STANDOFF THREADED		R 403	85124A55	RESISTOR	1.8K-5-14	
005	1	2-8788-0	CONNECTOR		R 404	85124E89	RESISTOR	2.2K-5-14	
006	4	84030-1	JACK PRINTED CIRCU		R 405	85124E02	RESISTOR	14.5-5-14	
007	1	8407-86	WASHER SHOULDER		R 406	85124739	RESISTOR	100-5-14	
008	1	840308-202	SCREW PIN	1380-33X-750	R 407	06-80270A44	RESISTOR	480-1-2	
010	1	840308-41	WASHER LOCK	138	R 408	85124A03	RESISTOR	3.9K-5-14	
011	1	84077-8B-5	WASHER FLAT	156	R 409	85124735	RESISTOR	100-5-14	
012	1	840308-202	NUT HEX	1380-32	R 410	8312471	RESISTOR	8.2K-5-14	
013	1	14-80203A48	INSULATOR INDUCTOR		R 411	85124A59	RESISTOR	2.7K-5-14	
014	AR	50888W9P3	SOLDER		R 412	83124A57	RESISTOR	2.2K-5-14	
015	AR	50888W9P3	SOLDER		R 413	85125E89	RESISTOR	3.9K-5-12	
016	AR	8418828-A20-9	WIRE SOLDER	#20 WHITE	R 414	85124A48	RESISTOR	750-5-14	
017	1	309320-21	WASHER PLAIN NYLON	#20	TR481	06-80331A88	JACK TIP	WHT	
C 401	1	21-80308A42	CAPACITOR	01UF-20V-80-200	TR482	06-80331A88	JACK TIP	WHT	
C 402	1	21-80308A75	CAPACITOR	470UF-30V	TR483	06-80331A88	JACK TIP	WHT	
C 403	1	21-80308A79	CAPACITOR	470UF-30V	TR484	06-80331A88	JACK TIP	WHT	
C 404	1	21-80308A82	CAPACITOR	01UF-20V-80-200	U 401	31-80208A87	INTEGRATED CIRCUIT	MC7819CT	
C 405	1	21-80308A82	CAPACITOR	01UF-20V-80-200	R 401	06-80340A71	WASHER		
C 406	1	21-80308A82	CAPACITOR	01UF-20V-80-200	VR401	48-80209C25	DIODE ZENER	15V-5-12	
C 407	1	21-80308A82	CAPACITOR	01UF-20V-80-200					
C 408	1	21-80308A82	CAPACITOR	01UF-20V-80-200					
C 409	1	21-80308A82	CAPACITOR	01UF-20V-80-200					
C 410	1	21-80308A75	CAPACITOR	100UF-30V					
C 411	1	21-80308A82	CAPACITOR	01UF-20V-80-200					
C 412	1	21-80308A82	CAPACITOR	01UF-20V-80-200					
C 413	1	21-80308A82	CAPACITOR	01UF-20V-80-200					
C 414	1	230A41818	CAPACITOR	4.7UF-50-20					
CR401	1	48-8880C47	DIODE						
CR402	1	48-8880C47	DIODE						
CR403	1	48-8880C47	DIODE						
CR404	1	48-8880C47	DIODE						
CR405	1	48-8880C47	DIODE						
CR406	1	48-8880C47	DIODE	100V					
CR407	1	48-8880C47	DIODE						
CR408	1	48-8880C47	DIODE	50V-1A					
CR409	1	48-8880C47	DIODE	100V					
CR410	1	48-8880C47	DIODE	100V					
CR411	1	48-8880C47	DIODE						
CR412	1	48-8880C47	DIODE						
CR413	1	48-8880C47	DIODE						
CR414	1	48-8880C47	DIODE						
CR415	1	48-8880C47	DIODE						
CR416	1	48-8880C47	DIODE						
CR417	1	48-8880C47	DIODE						
CR418	1	48-8880C47	DIODE						
CR419	1	48-8880C47	DIODE						
CR420	1	48-8880C47	DIODE						
K 401	1	80-80270A46	RELAY						
L 401	1	21-80308A77	INDUCTOR						
Q 402	1	48-80345A84	TRANSISTOR	MP5620 SCREENED					
Q 403	1	48-80345A81	TRANSISTOR	VN8AF SCREENED					
Q 404	1	48-80345A56	TRANSISTOR	MP5620 SCREENED					
Q 405	1	48-80345A81	TRANSISTOR	VN8AF SCREENED					
Q 406	1	48-80345A56	TRANSISTOR	VN8AF SCREENED					

Figure 7-16. Low Voltage Power Supply Relay Module A1A4 (01-80305A68) Parts Location Diagram (Sheet 2 of 3)



Find No.	Qty. Req.	Part No.	Nomenclature	Part Value
001	1	01-80305A67	RELAY PWB ASSEMBLY	
002	1	04-P0786V001	PLATE MOUNTING REL	
003	2	84032778-03P	INSULATOR PLATE FI	T0-3
004	4	8407-171	WASHER SHOULDER	
005	8	840308-202	SCREW PIN	1120-40X-375
006	8	04-7807	WASHER FLAT	.125
007	8	04-11458	WASHER LOCK	.112
008	2	84032778-70P	INSULATOR PLATE FI	STD MT
009	4	8-225-10E	TERMINAL CRAMP INSU	#10
010	4	801568P015	NUT HEX	15-32
011	4	801568P009	WASHER LOCK	#10-19
012	4	8407-88	WASHER SHOULDER	
013	AR	50888W9P3	WIRE ELEC	#16 WHT
014	AR	50888W9P3	SOLDER	
015	AR	11-14187A01	INK	BLACK
CR409	1	48-80345A86	DIODE	
CR410	1	48-80345A86	DIODE	
CR411	1	48-80345A86	DIODE	
CR412	1	48-80345A86	DIODE	
Q 401	1	48-80306A89	TRANSISTOR	
Q 406	1	48-80306A89	TRANSISTOR	

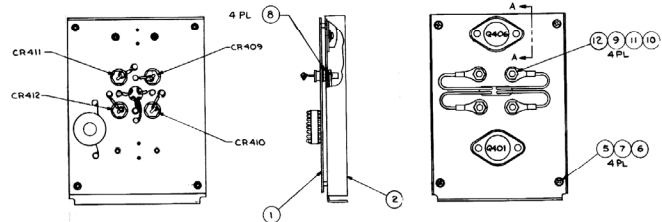

Low Voltage Power Supply Relay End Plate Assembly

Figure 7-16. Low Voltage Power Supply Relay Module A1A4 (01-80305A68) Parts Location Diagram (Sheet 3 of 3)

Part No.	Qty Req.	Part No.	Nomenclature	Part Value
001	1	64-P07811001	MOTHER BOARD	
002	6	810M-8-15-A	SPACER RING	
003	AR	5HG2WHP3	SOLDER	BLACK
004	AR	11-14-87A01	INK	
005	2	W232-266	NUT, PRESS, MIN	
006	AR	W18226-A22-9	WIRE SOLDER	#22 WHITE P
J101	1	2-81833-2	CONNECTOR	
J102	1	09-80331A99	CONNECTOR EDGE CAR	
J103	1	09-80331A99	CONNECTOR EDGE CAR	
J104	1	2-81833-2	CONNECTOR	
J105	1	1-87227-3	CONNECTOR	
J106	1	09-80331A95	SOCKET SOLDER DIP	
J107	1	09-80331A87	SOCKET SOLDER DIP	
J108	1	09-80331A96	SOCKET SOLDER DIP	14 PIN

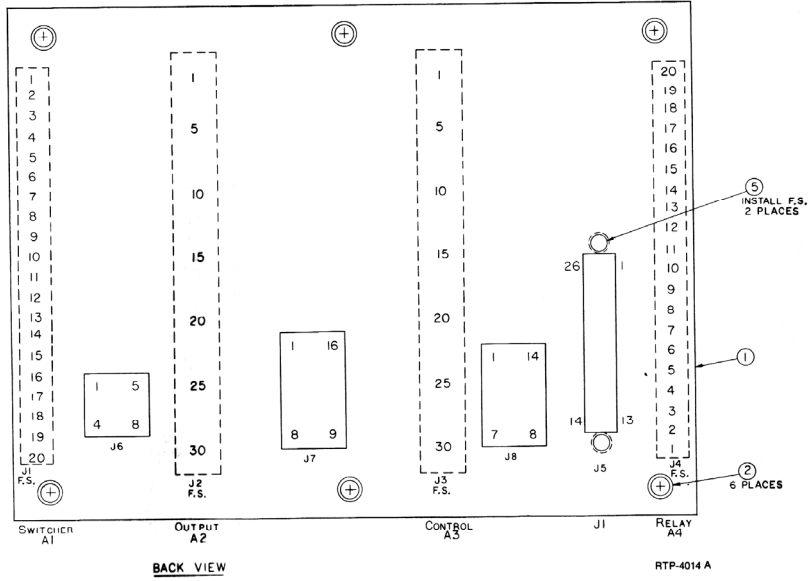

Figure 7-17. Low Voltage Power Supply A1
Motherboard Parts Location

SECTION 8 SCOPE AMPLIFIER (A2)

8-1. General. The Scope Amplifier module contains the horizontal and vertical deflection amps, the horizontal timebase generator, focus and intensity control circuitry, and miscellaneous CRT bias adjustments. A block diagram of the Scope Amplifier module is shown in figure 8-1 with its schematic shown in figure 8-2.

8-2. Deflection Amplifiers. The vertical and horizontal deflection amplifiers are identical. The input signal is initially amplified and split into two signals 180° out of phase. Each of the two signals is then further amplified to become the CRT deflection plate signals. The amplifiers provide up to 200 volts peak-peak signal capability with a 1 MHz frequency bandwidth.

8-3. Horizontal Timebase Generator. The horizontal timebase generator provides calibrated sweep rates over a six decade range from 1 μ sec to 100 msec per division. Sweep rate selection is from the processor via the SCOPE SWP CONT 0-7 signal lines. Vernier control over the sweep rate is via the SWP VERN VOLT input from the front panel. Sweep triggering is either the auto or normal mode as selected by the AUTO/NOR TRIG SEL line from the front panel. In the auto mode, if the SYNC PRESENT input is high indicating no sync, the scope sweep is self triggered after a hold off time. If there is a sync present, the sweep will wait for a pulse on the TRIG PULSE line to start the sweep after the hold off time. For the normal trigger mode the sweep will always wait for a TRIG PULSE input.

8-4. A sweep cycle consists of two parts, the sweep and the hold off. During the sweep the CRT is unblanked via the SWP BLANKING line and the horizontal trace is made. At the end of the sweep the CRT is blanked and the hold off time begins. During the hold off time, which is equal to the sweep time, the sweep generator and trigger circuits are reset in preparation for the next sweep.

See "CAUTION" note on page 4-19

8-5. Horizontal Switching. The input to the horizontal deflection amp is selected between two sources. The INT HORIZ IN signal line provides the horizontal character sweep and the horizontal spectrum analyzer sweep. The other source is the scope mode signal path from the horizontal positioning summing amp. The scope mode signal is either the output of the Horizontal Timebase Generator or the EXT HORIZ INPUT from the front panel. Selection between internal horizontal and scope mode horizontal inputs is via the SCOPE MODE EN line from the processor. Selection between the two scope mode signals is via the EXT HORIZ EN line.

8-6. Intensity Control. A crossover network is used to provide CRT Z-axis modulation from DC to 1 MHz. The INTEN LVL signal from the front panel control is gated with the SCOPE Z-AXIS signal by the intensity Level Gate. The gated signal is summed with the HV REF and INTEN SMPL VOLT signals to provide the INTEN TV signal. The INTEN TV (Intensity Tracking Voltage) is the low frequency control path which drives the intensity optoisolator in the High Voltage Supply.

8-7. The high frequency modulation path is via the Z-Axis Modulator circuit. The resulting CRT Z-AXIS signal is capacitively coupled to the CRT grid.

8-8. Focus Control. The FOCUS TV (Focus Tracking Voltage) signal is obtained by comparing the FOCUS LEVEL control line to the FOCUS SAMPLE VOLT signal. The tracking voltage signal drives an optoisolator circuit in the High Voltage Supply which controls the CRT focus voltage.

8-9. Astigmatism, Geometry, and Trace Rotation. These three CRT alignment controls are obtained from the respective wipers of three potentiometers. Each potentiometer is connected between supply voltages equal to the adjustment range required.

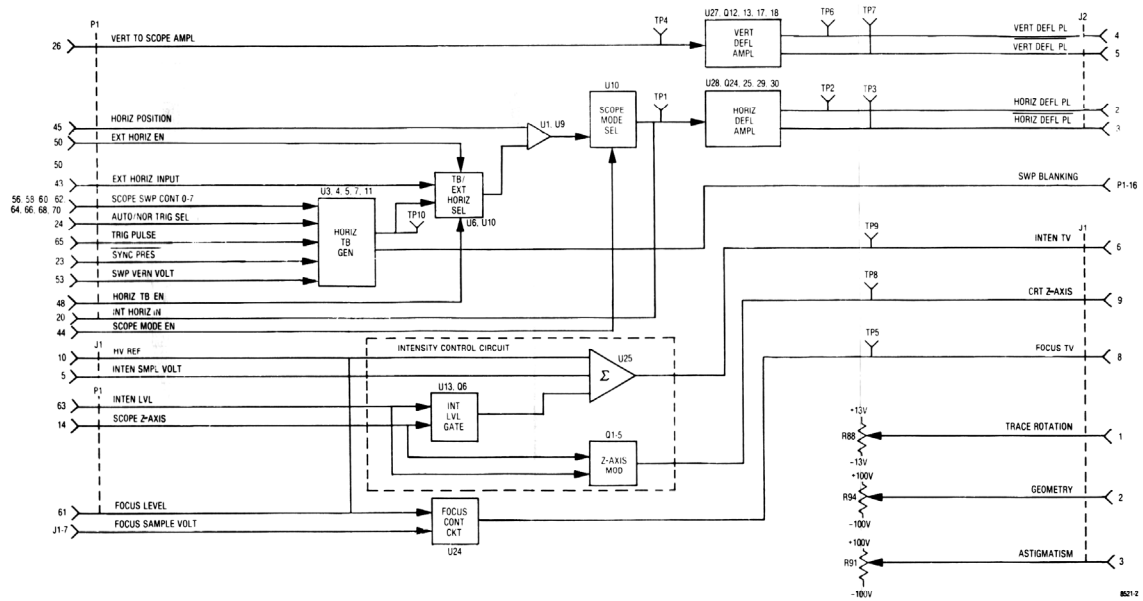

Figure 8-1. Vertical/Horizontal Scope Amplifier A2 Block Diagram

8-3

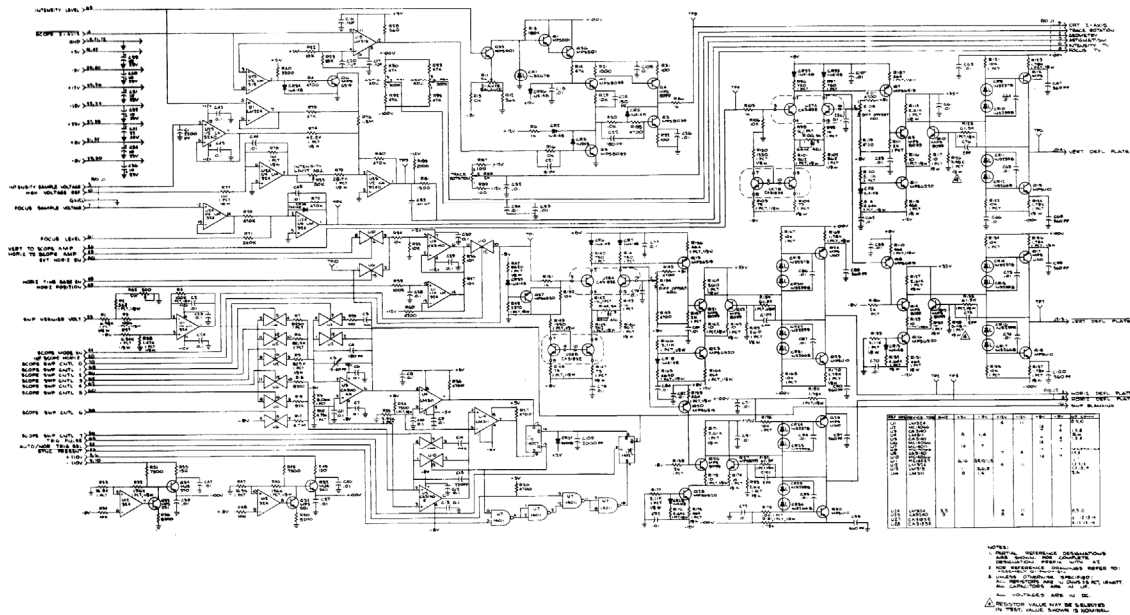

Figure 8-2. Vertical/Horizontal Scope Amplifier A2 Schematic Diagram

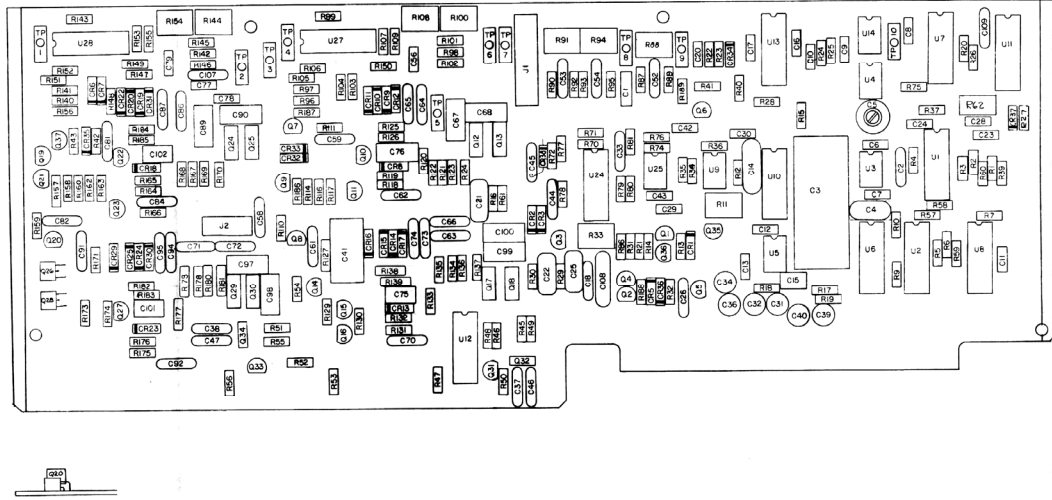

Figure 8-3. Vertical/Horizontal Scope Amplifier Module A2 (RTC-4007B) Parts Location

Find No.	Qty. Req.	Part No.	Nomenclature	Part Value	Find No.	Qty. Req.	Part No.	Nomenclature	Part Value	Find No.	Qty. Req.	Part No.	Nomenclature	Part Value
		RTC-4007B	SCOPE AMPLIFIER											
001	1	84-2023A14	PWR.SCOPE.HORZIVE		C 064	1	21-8029A52	CAPACITOR	01UF-20-80-200	J001	1	1-60456-9	CONNECTOR	
002	AR	5428280A93	SOLDER		C 065	1	21-8029A52	CAPACITOR	01UF-20-80-200	J002	1	60456-9	CONNECTOR	
003	AR	11-14817A21	RK	BLACK	C 066	1	21-8029A52	CAPACITOR	01UF-20-80-200	G 001	1	48-8034A49	TRANSISTOR	MPS 001 SCR
004	4	30-80014A44	HFAT RING TRANSIST		C 067	1	21-8029A50	CAPACITOR	500PF-10-500	G 002	1	48-8034A51	TRANSISTOR	
005	2	42-80017A001	BLACK TRANSFORM M		C 068	1	21-8029A50	CAPACITOR	500PF-10-500	G 003	1	48-8034A51	TRANSISTOR	
006	8	N43862-2-4	SCREW	4-888-14	C 070	1	21-8029A52	CAPACITOR	01UF-20-80-200	G 004	1	48-8034A51	TRANSISTOR	
007	4	N43862-2-15	SCREW	4-888-15B	C 071	1	21-8029A52	CAPACITOR	01UF-20-80-200	G 005	1	48-8034A51	TRANSISTOR	
008	4	04-114483	WASHER-LOCK	118	C 072	1	21-8029A52	CAPACITOR	01UF-20-80-200	G 006	1	48-8034A52	TRANSISTOR	MPS019 SCR
009	4	02-7013	NUT	119H-4	C 074	1	21-8029A52	CAPACITOR	01UF-20-80-200	G 007	1	48-8034A52	TRANSISTOR	MPS019 SCR
010	4	20-14232A-10	IDENTIFICATION.PLA		C 076	1	21-8029A52	CAPACITOR	01UF-20-80-200	G 008	1	48-8034A52	TRANSISTOR	MPS019 SCR
012	10	08-8031A488	JACK.TP	WHIT	C 077	1	21-14032087	CAPACITOR	2PF-5PF-500	G 009	1	48-8034A51	TRANSISTOR	MPS019 SCR
013	AR	R1V210	COATING.SILOCON		C 078	1	21-8029A49	CAPACITOR	1UF-20-100	G 010	1	48-8034A51	TRANSISTOR	MPS019 SCR
014	1	40-800817A002	BLACK TRANSFORM M		C 079	1	21-8029A49	CAPACITOR	1UF-20-100	G 011	1	48-8034A52	TRANSISTOR	MPS019 SCR
C 001	1	08-03789-01	CAPACITOR	0000PF-8-80	C 081	1	21-8029A52	CAPACITOR	01UF-20-80-200	G 014	1	48-8034A51	TRANSISTOR	
C 002	1	21-8029A52	CAPACITOR	1UF-20-80-200	C 082	1	21-8029A52	CAPACITOR	01UF-20-80-200	G 015	1	48-8034A51	TRANSISTOR	
C 003	1	08-804-1050	CAPACITOR	1UF-20-80-200	C 084	1	21-8029A52	CAPACITOR	01UF-20-80-200	G 016	1	48-8034A51	TRANSISTOR	MPS019 SCR
C 004	1	21-8029A52	CAPACITOR	1UF-20-80-200	C 086	1	21-8029A52	CAPACITOR	01UF-20-80-200	G 017	1	48-8034A51	TRANSISTOR	MPS019 SCR
C 005	1	20-082890007	CAPACITOR.VARIABLE	10-50PF	C 087	1	21-8029A52	CAPACITOR	01UF-20-80-200	G 018	1	48-8034A51	TRANSISTOR	MPS019 SCR
C 006	1	21-8029A49	CAPACITOR	1UF-20-100	C 088	1	21-8029A50	CAPACITOR	500PF-10-500	G 019	1	48-8034A52	TRANSISTOR	MPS019 SCR
C 007	1	21-8029A49	CAPACITOR	1UF-20-100	C 090	1	21-8029A50	CAPACITOR	500PF-10-500	G 020	1	48-8034A52	TRANSISTOR	MPS019 SCR
C 008	1	21-8029A49	CAPACITOR	1UF-20-100	C 091	1	21-8029A52	CAPACITOR	01UF-20-80-200	G 021	1	48-8034A51	TRANSISTOR	MPS019 SCR
C 009	1	21-8029A49	CAPACITOR	1UF-20-100	C 092	1	21-8029A52	CAPACITOR	01UF-20-80-200	G 022	1	48-8034A51	TRANSISTOR	MPS019 SCR
C 010	1	21-8029A49	CAPACITOR	1UF-20-100	C 094	1	21-8029A52	CAPACITOR	01UF-20-80-200	G 024	1	48-8034A48	TRANSISTOR	MPS019 SCR
C 011	1	21-8029A49	CAPACITOR	1UF-20-100	C 095	1	21-8029A52	CAPACITOR	01UF-20-80-200	G 025	1	48-8034A47	TRANSISTOR	MPS019 SCR
C 012	1	21-8029A49	CAPACITOR	1UF-20-100	C 097	1	41-9025A-09	CAPACITOR	400PF-10-400	G 026	1	48-8034A51	TRANSISTOR	MPS019 SCR
C 013	1	21-8029A49	CAPACITOR	1UF-20-100	C 098	1	21-8029A50	CAPACITOR	500PF-10-500	G 028	1	48-8034A51	TRANSISTOR	MPS019 SCR
C 014	1	08-038196-08	CAPACITOR	002UF-10-100	C 099	1	21-8029A50	CAPACITOR	500PF-10-500	G 029	1	48-8034A48	TRANSISTOR	MPS019 SCR
C 015	1	21-088197088	CAPACITOR	500PF-10-500	C 100	1	21-8029A50	CAPACITOR	500PF-10-500	G 030	1	48-8034A47	TRANSISTOR	MPS019 SCR
C 016	1	21-8029A49	CAPACITOR	1UF-20-100	C 101	1	21-14032087	CAPACITOR	2PF-5PF-500	G 031	1	48-8034A48	TRANSISTOR	MPS019 SCR
C 017	1	21-8029A49	CAPACITOR	1UF-20-100	C 102	1	21-14032087	CAPACITOR	2PF-5PF-500	G 032	1	48-8034A47	TRANSISTOR	MPS019 SCR
C 018	1	21-8029A52	CAPACITOR	01UF-20-80-200	C 107	1	21-8029A52	CAPACITOR	01UF-20-80-200	G 033	1	48-8034A49	TRANSISTOR	MPS 019 SCR
C 020	1	21-8029A49	CAPACITOR	1UF-20-100	C 108	1	21-8029A52	CAPACITOR	01UF-20-80-200	G 034	1	48-8034A46	TRANSISTOR	MPS 019 SCR
C 021	1	21-084450201	CAPACITOR	10PF-5-500	C 109	1	21-084450201	CAPACITOR	2000PF-10-200	G 035	1	48-8034A49	TRANSISTOR	MPS 019 SCR
C 022	1	21-084450201	CAPACITOR	10PF-5-500	C 110	1	48-8034A52	DIODE	33V-5-5	G 036	1	48-8034A49	TRANSISTOR	MPS 019 SCR
C 023	1	21-8029A49	CAPACITOR	1UF-20-100	C 111	1	48-8034A52	DIODE	33V-5-5	G 037	1	48-8034A49	TRANSISTOR	MPS 019 SCR
C 024	1	21-8029A49	CAPACITOR	1UF-20-100	C 112	1	48-8034A52	DIODE	33V-5-5	G 038	1	48-8034A49	TRANSISTOR	MPS 019 SCR
C 025	1	21-8029A49	CAPACITOR	1UF-20-100	C 113	1	48-8034A52	DIODE	33V-5-5	G 039	1	48-8034A49	TRANSISTOR	MPS 019 SCR
C 026	1	21-8029A49	CAPACITOR	1UF-20-100	C 114	1	48-8034A52	DIODE	33V-5-5	G 040	1	48-8034A49	TRANSISTOR	MPS 019 SCR
C 027	1	21-8029A49	CAPACITOR	1UF-20-100	C 115	1	48-8034A52	DIODE	33V-5-5	G 041	1	48-8034A49	TRANSISTOR	MPS 019 SCR
C 028	1	21-8029A52	CAPACITOR	01UF-20-80-200	C 116	1	48-8034A52	DIODE	33V-5-5	G 042	1	48-8034A49	TRANSISTOR	MPS 019 SCR
C 029	1	21-8029A49	CAPACITOR	1UF-20-100	C 117	1	48-8034A52	DIODE	33V-5-5	G 043	1	48-8034A49	TRANSISTOR	MPS 019 SCR
C 030	1	21-8029A49	CAPACITOR	1UF-20-100	C 118	1	48-8034A52	DIODE	33V-5-5	G 044	1	48-8034A49	TRANSISTOR	MPS 019 SCR
C 031	1	20-8029A49	CAPACITOR	1UF-20-100	C 119	1	48-8034A52	DIODE	33V-5-5	G 045	1	48-8034A49	TRANSISTOR	MPS 019 SCR
C 032	1	20-8029A49	CAPACITOR	1UF-20-100	C 120	1	48-8034A52	DIODE	33V-5-5	G 046	1	48-8034A49	TRANSISTOR	MPS 019 SCR
C 033	1	21-8029A52	CAPACITOR	01UF-20-80-200	C 121	1	48-8034A52	DIODE	33V-5-5	G 047	1	48-8034A49	TRANSISTOR	MPS 019 SCR
C 034	1	21-8029A52	CAPACITOR	01UF-20-80-200	C 122	1	48-8034A52	DIODE	33V-5-5	G 048	1	48-8034A49	TRANSISTOR	MPS 019 SCR
C 035	1	21-8029A52	CAPACITOR	01UF-20-80-200	C 123	1	48-8034A52	DIODE	33V-5-5	G 049	1	48-8034A49	TRANSISTOR	MPS 019 SCR
C 036	1	21-8029A52	CAPACITOR	01UF-20-80-200	C 124	1	48-8034A52	DIODE	33V-5-5	G 050	1	48-8034A49	TRANSISTOR	MPS 019 SCR
C 037	1	21-8029A52	CAPACITOR	01UF-20-80-200	C 125	1	48-8034A52	DIODE	33V-5-5	G 051	1	48-8034A49	TRANSISTOR	MPS 019 SCR
C 038	1	21-8029A52	CAPACITOR	01UF-20-80-200	C 126	1	48-8034A52	DIODE	33V-5-5	G 052	1	48-8034A49	TRANSISTOR	MPS 019 SCR
C 039	1	21-8029A52	CAPACITOR	01UF-20-80-200	C 127	1	48-8034A52	DIODE	33V-5-5	G 053	1	48-8034A49	TRANSISTOR	MPS 019 SCR
C 040	1	21-8029A52	CAPACITOR	01UF-20-80-200	C 128	1	48-8034A52	DIODE	33V-5-5	G 054	1	48-8034A49	TRANSISTOR	MPS 019 SCR
C 041	1	21-8029A52	CAPACITOR	01UF-20-80-200	C 129	1	48-8034A52	DIODE	33V-5-5	G 055	1	48-8034A49	TRANSISTOR	MPS 019 SCR
C 042	1	21-8029A52	CAPACITOR	01UF-20-80-200	C 130	1	48-8034A52	DIODE	33V-5-5	G 056	1	48-8034A49	TRANSISTOR	MPS 019 SCR
C 043	1	21-8029A52	CAPACITOR	01UF-20-80-200	C 131	1	48-8034A52	DIODE	33V-5-5	G 057	1	48-8034A49	TRANSISTOR	MPS 019 SCR
C 044	1	21-8029A52	CAPACITOR	01UF-20-80-200	C 132	1	48-8034A52	DIODE	33V-5-5	G 058	1	48-8034A49	TRANSISTOR	MPS 019 SCR
C 045	1	21-8029A52	CAPACITOR	01UF-20-80-200	C 133	1	48-8034A52	DIODE	33V-5-5	G 059	1	48-8034A49	TRANSISTOR	MPS 019 SCR
C 046	1	21-8029A52	CAPACITOR	01UF-20-80-200	C 134	1	48-8034A52	DIODE	33V-5-5	G 060	1	48-8034A49	TRANSISTOR	MPS 019 SCR
C 047	1	21-8029A52	CAPACITOR	01UF-20-80-200	C 135	1	48-8034A52	DIODE	33V-5-5	G 061	1	48-8034A49	TRANSISTOR	MPS 019 SCR
C 048	1	21-8029A52	CAPACITOR	01UF-20-80-200	C 136	1	48-8034A52	DIODE	33V-5-5	G 062	1	48-8034A49	TRANSISTOR	MPS 019 SCR
C 049	1	21-8029A52	CAPACITOR	01UF-20-80-200	C 137	1	48-8034A52	DIODE	33V-5-5	G 063	1	48-8034A49	TRANSISTOR	MPS 019 SCR
C 050	1	21-8029A52	CAPACITOR	01UF-20-80-200	C 138	1	48-8034A52	DIODE	33V-5-5	G 064	1	48-8034A49	TRANSISTOR	MPS 019 SCR
C 051	1	21-8029A52	CAPACITOR	01UF-20-80-200	C 139	1	48-8034A52	DIODE	33V-5-5	G 065	1	48-8034A49	TRANSISTOR	MPS 019 SCR
C 052	1	21-8029A52	CAPACITOR	01UF-20-80-200	C 140	1	48-8034A52	DIODE	33V-5-5	G 066	1	48-8034A49	TRANSISTOR	MPS 019 SCR
C 053	1	21-8029A52	CAPACITOR	01UF-20-80-200	C 141	1	48-8034A52	DIODE	33V-5-5	G 067	1	48-8034A49	TRANSISTOR	MPS 019 SCR
C 054	1	21-8029A52	CAPACITOR	01UF-20-80-200	C 142	1	48-8034A52	DIODE	33V-5-5	G 068	1	48-8034A49	TRANSISTOR	MPS 019 SCR
C 055	1	21-8029A52	CAPACITOR	01UF-20-80-200	C 143	1	48-8034A52	DIODE	33V-5-5	G 069	1	48-8034A49	TRANSISTOR	MPS 019 SCR
C 056	1	21-8029A52	CAPACITOR	01UF-20-80-200	C 144	1	48-8034A52	DIODE	33V-5-5	G 070	1	48-8034A49	TRANSISTOR	MPS 019 SCR
C 057	1	21-8029A52	CAPACITOR	01UF-20-80-200										

Find No.	Qty. Req.	Part No.	Nomenclature	Part Value	Find No.	Qty. Req.	Part No.	Nomenclature	Part Value	Find No.	Qty. Req.	Part No.	Nomenclature	Part Value
R 023	1	65124473	RESISTOR	10K-5-14	R 103	1	06-10621485	RESISTOR	75-1-18	R 152	1	65124455	RESISTOR	47K-5-14
R 024	1	06-10621C78	RESISTOR	7500-1-18	R 104	1	06-10621485	RESISTOR	75-1-18	R 154	1	1802042070	RESISTOR VARIABLE	1K
R 025	1	0608184630	RESISTOR	3.30K-5-14	R 105	1	65124449	RESISTOR	10K-5-14	R 155	1	65124465	RESISTOR	47K-5-14
R 026	1	65124469	RESISTOR	47K-5-14	R 106	1	65124473	RESISTOR	10K-5-14	R 156	1	06-10621B82	RESISTOR	454-1-18
R 027	1	65124465	RESISTOR	47K-5-14	R 107	1	65124465	RESISTOR	47K-5-14	R 157	1	0608187862	RESISTOR	2K-1-14
R 028	1	65124465	RESISTOR	500-5-14	R 108	1	1808445209	RESISTOR VARIABLE	1K	R 158	1	0608187862	RESISTOR	2K-1-14
R 029	1	65124473	RESISTOR	10K-5-14	R 109	1	65124465	RESISTOR	47K-5-14	R 159	1	06-10621B82	RESISTOR	454-1-18
R 030	1	65124473	RESISTOR	10K-5-14	R 110	1	06-10621B82	RESISTOR	454-1-18	R 160	1	06-10621C38	RESISTOR	2610-1-18
R 031	1	65124469	RESISTOR	100-5-14	R 111	1	0608187862	RESISTOR	2K-1-14	R 162	1	06-10621A01	RESISTOR	10-1-18
R 032	1	65124425	RESISTOR	100-5-14	R 112	1	06-10621C25	RESISTOR	2610-1-18	R 163	1	06-10621A01	RESISTOR	10-1-18
R 033	1	1802042070	RESISTOR VARIABLE	50K	R 113	1	06-10621A01	RESISTOR	10-1-18	R 164	1	06-10621B82	RESISTOR	454-1-18
R 034	1	65124473	RESISTOR	10K-5-14	R 114	1	06-10621A01	RESISTOR	10-1-18	R 165	1	06-10621C59	RESISTOR	4540-1-18
R 035	1	65124473	RESISTOR	10K-5-14	R 115	1	06-10621A01	RESISTOR	10-1-18	R 166	1	06-10621C30	RESISTOR	5110-1-18
R 036	1	65124473	RESISTOR	10K-5-14	R 116	1	06-10621A01	RESISTOR	454-1-18	R 167	1	0608187862	RESISTOR	10K-1-14
R 037	1	65124473	RESISTOR	10K-5-14	R 117	1	06-10621C59	RESISTOR	4540-1-18	R 168	1	0608187862	RESISTOR	10K-1-14
R 038	1	65124487	RESISTOR	100K-5-14	R 118	1	0608187862	RESISTOR	454-1-18	R 169	1	06-10621C19	RESISTOR	1780-1-18
R 040	1	65124466	RESISTOR	3.3K-5-14	R 119	1	0608187862	RESISTOR	4540-1-18	R 170	1	06-10621C19	RESISTOR	1780-1-18
R 041	1	65124465	RESISTOR	47K-5-14	R 120	1	06-10621C63	RESISTOR	5110-1-18	R 171	1	06-10621C35	RESISTOR	2610-1-18
R 042	1	06-10621C37	RESISTOR	9020-1-18	R 121	1	0608187862	RESISTOR	454-1-18	R 172	1	06-10621A01	RESISTOR	10-1-18
R 043	1	06-10621C31	RESISTOR	2730-1-18	R 122	1	0608187862	RESISTOR	454-1-18	R 173	1	06-10621A01	RESISTOR	10-1-18
R 045	1	65124470	RESISTOR	7.5K-5-14	R 123	1	06-10621C19	RESISTOR	1780-1-18	R 174	1	06-10621A01	RESISTOR	10-1-18
R 046	1	06-10621E17	RESISTOR	199K-1-18	R 124	1	06-10621C19	RESISTOR	1780-1-18	R 175	1	06-10621B82	RESISTOR	454-1-18
R 047	1	0608187862	RESISTOR	18.8K-1-14	R 125	1	06-10621C35	RESISTOR	2610-1-18	R 176	1	06-10621C59	RESISTOR	4540-1-18
R 048	1	65124473	RESISTOR	10K-5-14	R 126	501	06-10621C38	RESISTOR	2610-1-18	R 177	1	06-10621C63	RESISTOR	5110-1-18
R 049	1	65124429	RESISTOR	10K-5-14	R 127	1	06-10621C39	RESISTOR	2870-1-18	R 178	1	0608187862	RESISTOR	10K-1-14
R 050	1	65124471	RESISTOR	8.2K-5-14	R 128	501	06-10621C47	RESISTOR	3090-1-18	R 179	1	0608187862	RESISTOR	10K-1-14
R 051	1	65124470	RESISTOR	7.5K-5-14	R 129	1	06-10621C47	RESISTOR	3480-1-18 NOMINAL	R 180	1	06-10621C19	RESISTOR	1780-1-18
R 052	1	06-10621E17	RESISTOR	199K-1-18	R 130	501	06-10621C31	RESISTOR	3030-1-18	R 181	1	06-10621C19	RESISTOR	1780-1-18
R 053	1	0608187862	RESISTOR	18.8K-1-14	R 131	501	06-10621C30	RESISTOR	4200-1-18	R 182	1	06-10621C38	RESISTOR	61.9K-1-18
R 054	1	65124473	RESISTOR	10K-5-14	R 132	501	06-10621C59	RESISTOR	4540-1-18	R 183	1	06-10621C35	RESISTOR	2610-1-18
R 055	1	65124429	RESISTOR	10K-5-14	R 133	501	06-10621C39	RESISTOR	4540-1-18	R 184	1	06-10621D68	RESISTOR	61.9K-1-18
R 056	1	65124471	RESISTOR	8.2K-5-14	R 134	1	06-10621C35	RESISTOR	2610-1-18	R 185	1	06-10621C29	RESISTOR	2910-1-18
R 057	1	06-10621C72	RESISTOR	6340-1-18	R 135	1	06-10621C35	RESISTOR	2610-1-18	R 186	1	0608187862	RESISTOR	2K-1-14
R 058	1	06-10621C11	RESISTOR	1470-1-18	R 136	1	06-10621A01	RESISTOR	10-1-18	R 187	1	06-10621B82	RESISTOR	454-1-18
R 059	1	65124465	RESISTOR	100-5-14	R 137	1	06-10621B82	RESISTOR	454-1-18	R 188	1	65124465	RESISTOR	47K-5-14
R 060	1	65124465	RESISTOR	47K-5-14	R 138	1	06-10621C28	RESISTOR	4540-1-18	R 189	1	65124465	RESISTOR	2.2K-5-14
R 061	1	65124469	RESISTOR	10K-5-14	R 139	1	06-10621C30	RESISTOR	5110-1-18	U 001	1	51-8039A16	INTEGRATED CIRCUIT	LM324N SCREENED
R 062	1	1802042070	RESISTOR VARIABLE	200-20-12	R 140	1	06-10621C31	RESISTOR	2730-1-18	U 002	1	51-8039A48	INTEGRATED CIRCUIT	MC1406BCP SCREENED
R 063	1	65124814	RESISTOR	470K-5-14	R 141	1	0608187862	RESISTOR	454-1-18	U 003	1	51-8039A48	INTEGRATED CIRCUIT	MC1406BCP SCREENED
R 064	1	65124814	RESISTOR	470K-5-14	R 142	1	0608187862	RESISTOR	454-1-18	U 004	1	51-8039A68	INTEGRATED CIRCUIT	LM311P SCREENED
R 065	1	65124806	RESISTOR	220K-5-14	R 143	1	06-10621C19	RESISTOR	1780-1-18	U 005	1	51-8039A01	INTEGRATED CIRCUIT	CA3140E SCREENED
R 066	1	65124814	RESISTOR	470K-5-14	R 144	1	06-10621C19	RESISTOR	1780-1-18	U 006	1	51-8039A48	INTEGRATED CIRCUIT	MC1406BCP SCREENED
R 067	1	06-10621D52	RESISTOR	42.2K-1-18	R 145	1	06-10621D68	RESISTOR	61.9K-1-18	U 007	1	51-8039A32	INTEGRATED CIRCUIT	MC1401BCP SCREENED
R 068	1	65124469	RESISTOR	47K-5-14	R 146	1	06-10621C35	RESISTOR	2610-1-18	U 008	1	51-8039A48	INTEGRATED CIRCUIT	MC1406BCP SCREENED
R 069	1	65124806	RESISTOR	1M-1-18	R 147	1	06-10621C31	RESISTOR	2730-1-18	U 009	1	51-8039A01	INTEGRATED CIRCUIT	CA3140E SCREENED
R 070	1	06-10621E85	RESISTOR	1M-1-18	R 148	501	06-10621C35	RESISTOR	2610-1-18	U 010	1	51-8039A48	INTEGRATED CIRCUIT	MC1406BCP SCREENED
R 071	1	06-10621E85	RESISTOR	1M-1-18	R 149	501	06-10621C39	RESISTOR	2870-1-18	U 011	1	51-8039A32	INTEGRATED CIRCUIT	MC1402BCP SCREENED
R 072	1	06-10621D26	RESISTOR	28.7K-1-18	R 150	501	06-10621C42	RESISTOR	3090-1-18	U 012	1	51-8039A48	INTEGRATED CIRCUIT	LM339N SCREENED
R 073	1	65124814	RESISTOR	470K-5-14	R 151	501	06-10621C42	RESISTOR	3180-1-18	U 013	1	51-8039A06	INTEGRATED CIRCUIT	LM319N SCREENED
R 074	1	65124814	RESISTOR	470K-5-14	R 152	1	06-10621C47	RESISTOR	3480-1-18 NOMINAL	U 014	1	51-8039A68	INTEGRATED CIRCUIT	LM311P SCREENED
R 075	1	65124833	RESISTOR	1.5K-5-14	R 153	501	06-10621C51	RESISTOR	3030-1-18	U 015	1	51-8039A48	INTEGRATED CIRCUIT	LM324N SCREENED
R 076	1	65124833	RESISTOR	1.5K-5-14	R 154	501	06-10621C51	RESISTOR	3030-1-18	U 016	1	51-8039A48	INTEGRATED CIRCUIT	LM324N SCREENED
R 077	1	65124425	RESISTOR	100-5-14	R 155	501	06-10621C59	RESISTOR	4540-1-18	U 017	1	51-8039A04A	INTEGRATED CIRCUIT	CA3204E SCREENED
R 078	1	1802042070	RESISTOR VARIABLE	2K	R 156	501	06-10621C59	RESISTOR	4540-1-18	U 018	1	51-8039A48	INTEGRATED CIRCUIT	CA3140E SCREENED
R 079	1	65124425	RESISTOR	100-5-14	R 157	501	06-10621C63	RESISTOR	5110-1-18	U 019	1	51-8039A48	INTEGRATED CIRCUIT	CA3140E SCREENED
R 080	1	65124489	RESISTOR	47K-5-14	R 158	1	06084441A8	RESISTOR	750-1-14	U 020	1	51-8039A48	INTEGRATED CIRCUIT	CA3140E SCREENED
R 081	1	1802042070	RESISTOR VARIABLE	500K	R 159	1	06084441A8	RESISTOR	750-1-14	U 021	1	51-8039A48	INTEGRATED CIRCUIT	CA3140E SCREENED
R 082	1	65124489	RESISTOR	47K-5-14	R 160	1	06084441A8	RESISTOR	1K-1-14	U 022	1	51-8039A48	INTEGRATED CIRCUIT	CA3140E SCREENED
R 083	1	65124489	RESISTOR	47K-5-14	R 161	1	1802042070	RESISTOR VARIABLE	50K					
R 084	1	1802042070	RESISTOR VARIABLE	500K	R 162	1	06-10621D70	RESISTOR	502-1-18					
R 085	1	65124489	RESISTOR	47K-5-14	R 163	1	06-10621D70	RESISTOR	502-1-18					
R 086	1	06084441A8	RESISTOR	750-1-14	R 164	1	06-10621D70	RESISTOR	502-1-18					
R 087	1	06084441A8	RESISTOR	750-1-14	R 165	1	06-10621A85	RESISTOR	75-1-18					
R 088	1	06084441A8	RESISTOR	1K-1-14	R 166	1	06-10621C07	RESISTOR	1300-1-18					
R 089	1	06-10621D70	RESISTOR	5K	R 167	1	06-10621C07	RESISTOR	1300-1-18					
R 090	1	1802042070	RESISTOR VARIABLE	502-1-18	R 168	1	65124445	RESISTOR	18.8-1-18					
R 091	1	06-10621B70	RESISTOR	502-1-18	R 169	1	65124445	RESISTOR	18.8-1-18					
R 092	1	06-10621B70	RESISTOR	502-1-18	R 170	1	65124445	RESISTOR	18.8-1-18					

Figure 8-3. Vertical/Horizontal Scope Amplifier Module A2 (RTC-4007B) Parts Location Diagram

SECTION 9

SCOPE/DVM CONTROL MODULE (A3)

9-1. General. A primary function of the Scope/DVM Control Module is to route the required measurement and viewing signals to the DVM and scope circuitry. A large portion of the displayed data is determined by the DVM measurements on internal signal points. Thus for a rapid update of several data displays it is necessary to time division multiplex several measurements points to the DVM. The DVM control circuitry and the system processor provide this function.

9-2. The scope control circuitry allows the system to display data information, internal modulation or demodulated signals, and external scope inputs as selected by the user. Provisions are also made for external horizontal inputs and a horizontal sweep that is coherent with the sweep generator for spectrum analyzer and filter alignment displays.

9-3. The control module also contains circuitry for single sideband demodulation and a IF phase locked loop for filtering and waveshaping the IF signal for frequency counting. A block diagram of the Scope/DVM Control module is shown in figure 9-1 with a schematic shown in figure 9-2.

9-4. Scope Vertical Control. The input to the scope vertical amplifier is switched between four different sources; the range switch (VERT FROM RNG SW), the vertical character sweep, the spectrum analyzer (SPECT ANA VERT), or the 455 kHz IF. Range switch inputs are from either the scope vertical input jack on the front panel or the internal modulation signals as selected by the modulation display control on this module. The vertical character sweep is a sawtooth waveform generated by the Vertical Character Sweep Generator and synced by the VERT CHAR SYNC signal from the character generator. The detected and amplified output of the receiver logarithmic IF is the vertical input for the spectrum analyzer. The remaining signal source is the second IF signal from the receiver for IF envelope observation.

9-5. For the spectrum analyzer and the scope sweep displays the Dual Display Control and Character Sweep Counter circuitry allow a single row of characters at the top of the CRT. This function is implemented with the Vertical Sweep Control by alternating the spectrum analyzer or the range switch signal with the vertical character sweep signal.

9-6. The dual display sequence of events starts with the Synthesizer Sweep Generator which is common to both display modes. When the synthesizer sweep is near its peak (scope horizontal sweep is at the edge of the screen) the Dual Display Control activates the CHAR GEN RST line and switches the scope vertical and horizontal inputs to their character generator sweeps. When the first character line has been traced, a transition on the LINE 1 input from the character generator resets the character generator sweeps and the character generator, increments the Character Sweep Counter, and thus causes line 1 to be traced again. This process repeats until four traces, as counted by the Character Sweep Counter, have been completed. At that point the counter resets the scope inputs back to the spectrum analyzer or range switch input. During the character display time the synthesizer sweep generator is reset and held until a transition on the SYNTH SWP SYNC line restarts the sweep. The timing of the process allows for the four character traces to be completed before the sweep sync occurs.

9-7. SSB Detection. Single Sideband (SSB) modulation is recovered by multiplying the 455 kHz IF signal with a 455 kHz beat frequency oscillator (BFO) signal. The BFO is controlled directly from the front panel and is adjustable over a 6 kHz frequency range. SSB AUDIO from the multiplier is routed to the receiver for post detection filtering. A sample of the BFO signal is made available to the frequency counter on the IF/BFO FREQ line for sideband frequency error determination.

9-8. 455 kHz PLL. For monitor frequency error determination a 455 kHz Phase Locked Loop (PLL) is used to filter and to shape the IF signal. The cleaned up signal is switched with the BFO signal to the frequency counter.

9-9. Scope Horizontal Control. Switching for the scope horizontal input is divided between two modules. The time base generator and the external horizontal input are selected on the scope amplifier module. The Horizontal Character Sweep Generator and the Synthesizer Sweep Generator signals are selected on the Control Module to the INT SCOPE HORIZ signal line.

9-10. For the dual display modes (characters and synthesizer sweep) the Horizontal Switch Control switches the horizontal input between the synthesizer sweep and the character sweep. This switching occurs simultaneously with that occurring in the scope vertical control as described in paragraph 9-6. The Horizontal Switch Control also provides the SCOPE MODE EN line to the scope amplifier to enable the scope mode horizontal inputs.

9-11. Synthesizer Sweep Control. The sweep signal generated by the Synthesizer Sweep Generator is controlled in amplitude and in range across the front panel sweep width control. Attenuations of 1.0 or 0.1 are provided by the Sweep Width Select circuitry to the sweep signal at the DISPERSION SWP signal line to the top of the width control. The bottom side of the width control is returned to the Sweep Width Select circuitry via the DISPERSION SWP RTN line. A 10 to 1 resistor change is made in the return line simultaneously with the attenuator change to give sweep ranges of 1-10 MHz and 0.01-1 MHz.

9-12. Scope Z-Axis Control. The SCOPE Z-AXIS signal has three possible sources as selected by the Z-Axis Control circuit. For character displays the Z-Axis signal is the CHAR GEN Z-AXIS from the character generator. The SWP BLANKING signal from the horizontal timebase generator is switched to the scope Z-Axis for the scope modes. For the remaining modes, spectrum analyzer and scope sweep, a logic zero level is gated to the Z-Axis input.

9-13. Modulation Display Control. Internal modulation or demodulated signals are displayed on the scope by switching the desired signal source to the input ranging switch and then switching the ranging switch output to the scope vertical input. The INTERNAL SCOPE AND PEAK DETECTOR SELECT circuitry switches DEMOD CAL AUDIO or AM CARRIER + MOD LEVEL or MOD CAL AUDIO to the internal scope and the peak detectors. The signals are gain adjusted before exiting the module from the INT SCOPE TO RANGING SWITCH output pin. The gains are processor selected.

9-14. The DEMOD CAL AUDIO signal from the receiver is either AM, FM, or SSB as determined by the operating mode. The peak signal level on this line is calibrated to 10 kHz/volt for FM and 10%/volt for AM. SSB signals are not calibrated.

9-15. For AM the CARRIER + MOD LVL input from the generator output detector provides a direct display of the modulation. This input is a DC level representative of the average output level plus an AC signal representative of the amplitude modulation on the output. For the scope modulation display the DC level is blocked so that only the AC component is observed. This input is uncalibrated for absolute AC levels, but the processor by determining the peak AC and average DC levels can determine the modulation depth.

9-16. For FM the MOD CAL AUDIO input from the audio synthesizer is calibrated to 5 kHz/volt for narrow band and to 20 kHz/volt for wide band. Correspondingly the display calibration attenuator has two gain ranges to maintain the same display calibration for both narrow and wide band.

9-17. Peak Detector. Each of the modulation and demodulation inputs can be selected to the peak detecting circuitry for the determination of % AM or kHz deviation. The peak detector circuitry provides DC outputs equal to the negative and positive peak values of the input signal relative to the average DC level of the signal. These levels are then digitized by the DVM and input to the processor where the modulation level is determined.

9-18. DVM Control. Any one of nine internal measurement points may be switched to INT DVM TO A/D. This signal is routed to the A7 (processor interface board) where it is multiplexed with external DVM data to the input of the analog to digital (A/D) converter. In general several internal measurement points must be input to the A/D converter to obtain all of the displayed data. Therefore the processor continuously cycles the INTERNAL DVM SELECT through the required measurement points stopping at each one long enough to digitize and input the data to the microprocessor.

9-19. The Internal DVM Select switch is followed by a range attenuator. As the processor cycles through the inputs it sets the range attenuator according to the last cycle reading made at that input. Thus each internal input is auto ranged over two decades to give three digit accuracy up to a maximum input of 10 volts. The internal DVM inputs and their function are listed in table 9-1.

Table 9-1. Internal DVM Inputs

+ Peak Voltage	Positive modulation measurements
- Peak Voltage	Negative modulation measurements
Carrier Level	RF output level
RF INPUT PWR	Power level applied to the RF input/output port
EXT FWD PWR	Forward power level on external inline wattmeter element
EXT RFL PWR	Reflected power level on external inline wattmeter element
BATT VOLT	Voltage level at DC input jack on the rear panel divided by 10
TEMP SENS VOLT	+5V level signal the processor that the RF load temperature is too high
SINAD/DISTORTION IN	DC level proportional to the signal power at the input of the SINAD/DISTORTION NOTCH filter

9-21. External DVM Distortion Control. External DVM and distortion inputs to the front panel jack are ranged by microprocessor control over four decades at the A12 (front panel interface) module. The resulting output is routed to the DVM FROM RNG SWITCH input of the A3 module. The signal is input to the DVM/DISTORTION SELECT circuitry and the gain of 6.5 preceding the 1 kHz notch filter.

9-22. Distortion Measurement. In the distortion mode the DVM/DISTORTION SELECT circuitry routes the output of the 1 kHz notch filter to the EXT DVM to A/D output pin where it is connected to the RMS to DC converter on the A7 (processor interface) module. The output of the RMS to DC converter is multiplexed to the A/D and read by the microprocessor. The input to the notch filter is rectified, filtered and applied to the INTERNAL DVM SELECT for reading by the microprocessor (refer to paragraph 9-19). The microprocessor divides the RMS output voltage of the notch filter by the average rectified input voltage to the notch filter to obtain the percent distortion for a 1 kHz input. The notch filter has a microprocessor controlled gain that is switched to either times one or times ten depending on input distortion and signal levels.

9-23. EXTERNAL DVM MEASUREMENT. In the external DVM mode the DVM FROM RNG SWITCH input is routed by the DVM/DISTORTION SELECT circuitry directly to the EXT DVM to A/D output where it is connected to the RMS to DC converter on the A7 (microprocessor interface) module. The output of the RMS to DC converter is multiplexed to the A/D converter where it is read by the microprocessor.

9-24. Module Control. Processor control of the Scope/DVM Control module is via the AF ADD BUS 0-3, the AF DATA BUS 0-3, and the AF BUS EN 1 signal lines. The four address bits are decoded by the Address Decode to determine which Control Latch the four bits of data will be latched into. The latching process is synchronized by the enable line. Control latches in addition to those necessary for controlling the module provide control for the Scope Amplifier module and part of the RF input module.

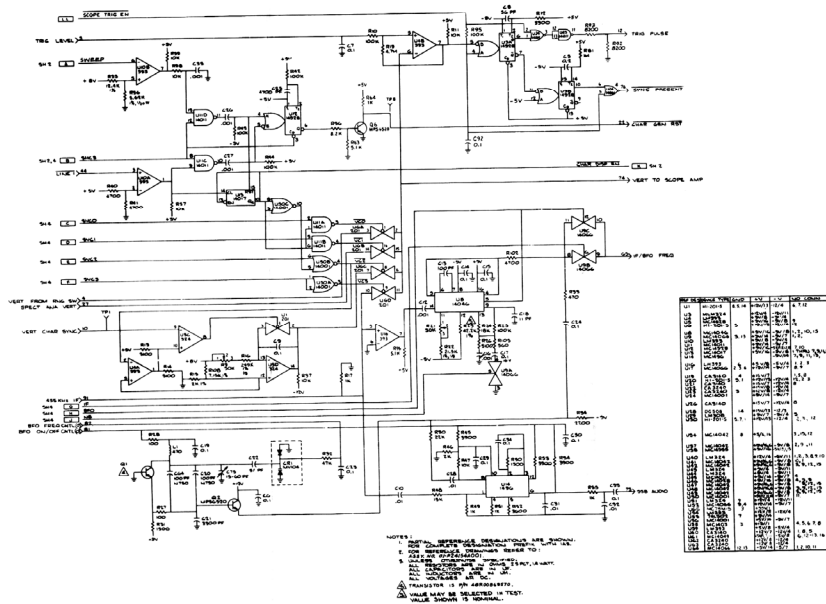

Figure 9-2. Scope/DVM Control Module A3 Schematic Diagram (Sheet 1 of 4)

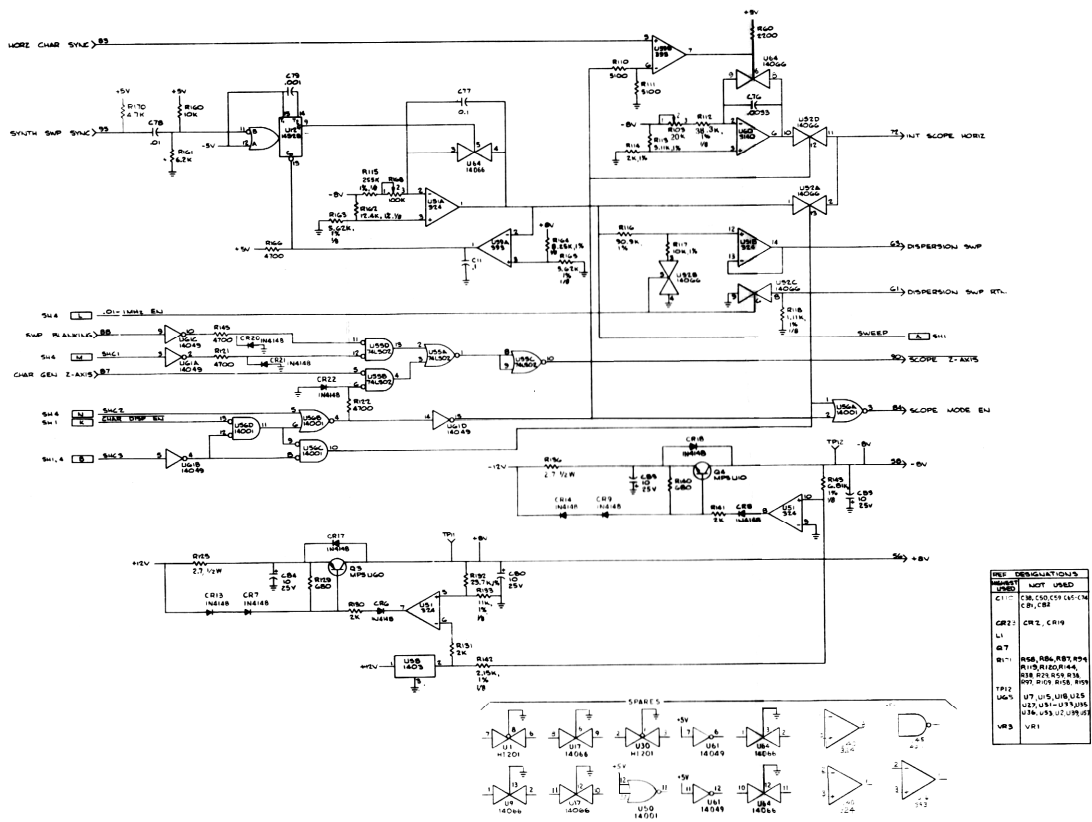

Figure 9-2. Scope/DVM Control Module A3 Schematic Diagram (Sheet 2 of 4)

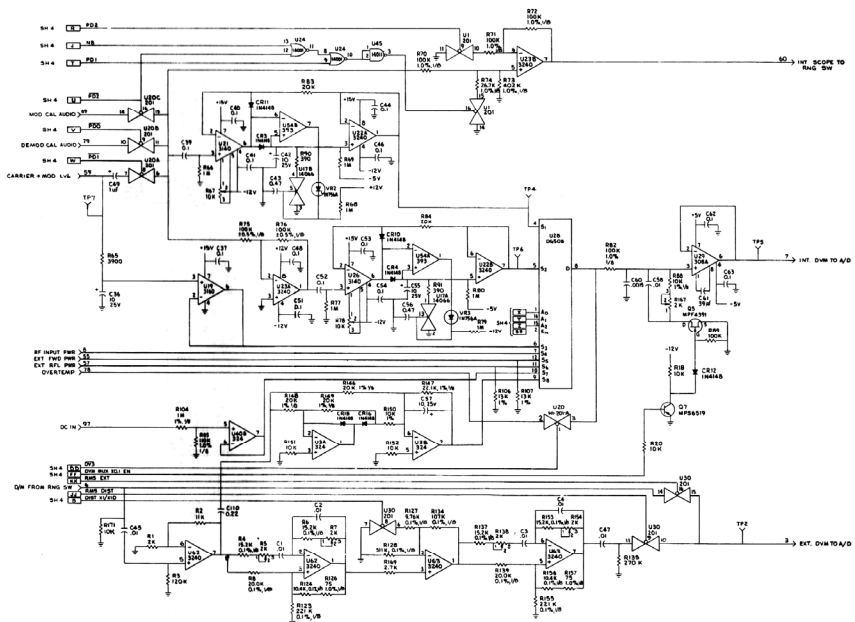

Figure 9-2. Scope/DVM Control Module A3 Schematic Diagram (Sheet 3 of 4)

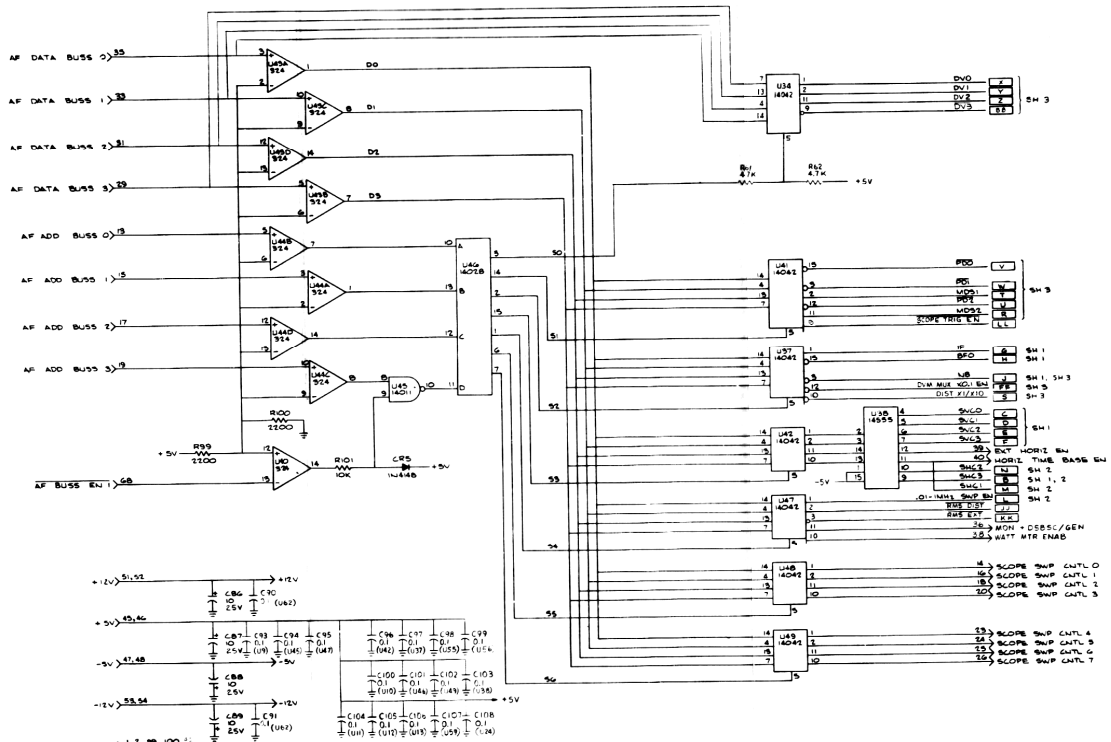

Figure 9-2. Scope/DVM Control Module A3
Schematic Diagram (Sheet 4 of 4)

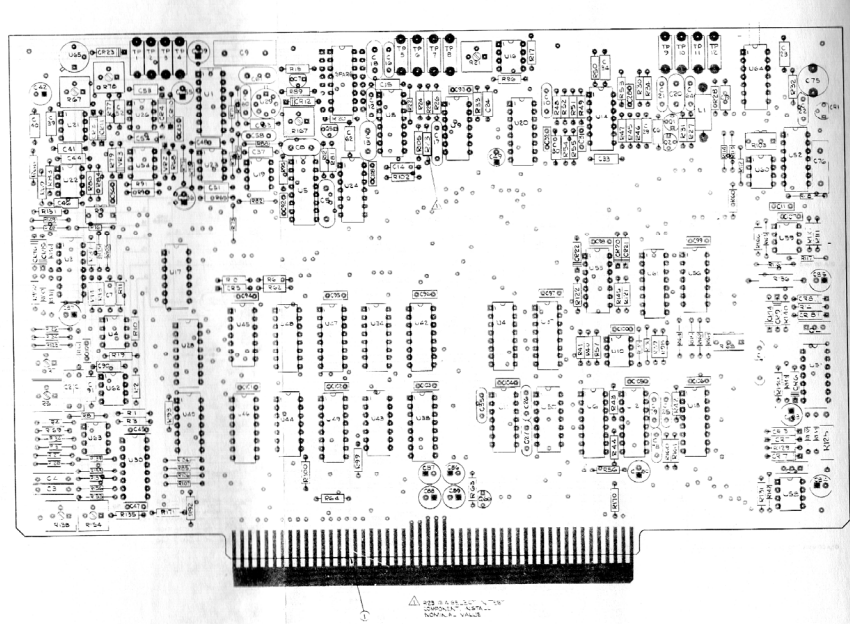

Figure 9-3. Scope/DVM Control Module
A3 (RTC-4024A) Parts Location
Diagram (Sheet 1 of 3)

Find No.	Qty. Req.	Part No.	Nomenclature	Part Value	Find No.	Qty. Req.	Part No.	Nomenclature	Part Value	Find No.	Qty. Req.	Part No.	Nomenclature	Part Value
001	1	RTC-4024	SCOPE/DVM CONTROL		C 001	1	21-00296404	CAPACITOR	399F-5.00	G 006	1	48-80369491	TRANSISTOR	MPF620 SCREENED
002	AR	84-P24171A01	PWR.SCOPE/DVM CONT		C 062	1	21-00296419	CAPACITOR	1UF-20-100	G 007	1	48-80369492	TRANSISTOR	MPF620 SCREENED
003	AR	1-114176A1	INK	BLACK	C 063	1	21-00296449	CAPACITOR	1UF-20-100	G 001	1	65124455	RESISTOR	2.0K-5-14
004	1	97-80236403	BRACKET/PWR.MTG		C 076	1	21-00296458	CAPACITOR	100PF-10-100	G 002	1	65124474	RESISTOR	11K-5-14
005	4	MS20370A02	EYEBOLT	1.8X3.312	C 075	1	19-80207039	CAPACITOR	15 TO 100PF-200	G 003	1	65124493	RESISTOR	120K-1-18
006	2	5C84500303	BRACKET		C 074	1	0808390525	CAPACITOR	0033-13-100	G 004	1	06-80356363	RESISTOR	15.2K-1-1.8
007	2	42CA384001	RETAINER		C 077	1	21-80384849	CAPACITOR	1UF-20-16	G 005	1	1803636702	RESISTOR VARIABLE	2K
008	4	20-12061	SCREW		C 078	1	21-80384852	CAPACITOR	01UF-20-90-200	G 006	1	06-80356363	RESISTOR	15.2K-1-1.8
009	1	21-80384853	CAPACITOR	4.4K-312	C 079	1	21-80384851	CAPACITOR	1000PF-10-100	G 007	1	1803636702	RESISTOR VARIABLE	2K
010	1	21-80384853	CAPACITOR	21UF-5-100	C 080	1	23-80296400	CAPACITOR	100UF-25V	G 008	1	06-80356364	RESISTOR	20K-1-1.8
011	1	21-80384853	CAPACITOR	01UF-5-100	C 083	1	23-80296400	CAPACITOR	100UF-25V	G 009	1	1803636701	RESISTOR VARIABLE	50K
012	1	21-80384853	CAPACITOR	01UF-5-100	C 084	1	23-80296400	CAPACITOR	100UF-25V	G 010	1	65124477	RESISTOR	100K-5-14
013	1	21-80384853	CAPACITOR	01UF-5-100	C 085	1	23-80296400	CAPACITOR	100UF-25V	G 011	1	65124473	RESISTOR	10K-5-14
014	1	21-80384853	CAPACITOR	01UF-5-100	C 086	1	23-80296400	CAPACITOR	100UF-25V	G 012	1	65124488	RESISTOR	3.9K-5-14
015	1	21-80384853	CAPACITOR	01UF-5-100	C 087	1	23-80296400	CAPACITOR	100UF-25V	G 013	1	65124488	RESISTOR	5.1K-5-14
016	1	21-80384853	CAPACITOR	01UF-5-100	C 088	1	23-80296400	CAPACITOR	100UF-25V	G 014	1	65124486	RESISTOR	5.1K-5-14
017	1	21-80384853	CAPACITOR	01UF-5-100	C 089	1	23-80296400	CAPACITOR	100UF-25V	G 015	1	65124486	RESISTOR	5.1K-5-14
018	1	21-80384853	CAPACITOR	01UF-5-100	C 090	1	23-80296400	CAPACITOR	100UF-25V	G 016	1	65124486	RESISTOR	5.1K-5-14
019	1	21-80384853	CAPACITOR	01UF-5-100	C 091	1	23-80296400	CAPACITOR	100UF-25V	G 017	1	65124486	RESISTOR	5.1K-5-14
020	1	21-80384853	CAPACITOR	01UF-5-100	C 092	1	23-80296400	CAPACITOR	100UF-25V	G 018	1	65124486	RESISTOR	5.1K-5-14
021	1	21-80384853	CAPACITOR	01UF-5-100	C 093	1	23-80296400	CAPACITOR	100UF-25V	G 019	1	65124486	RESISTOR	5.1K-5-14
022	1	21-80384853	CAPACITOR	01UF-5-100	C 094	1	23-80296400	CAPACITOR	100UF-25V	G 020	1	65124486	RESISTOR	5.1K-5-14
023	1	21-80384853	CAPACITOR	01UF-5-100	C 095	1	23-80296400	CAPACITOR	100UF-25V	G 021	1	65124486	RESISTOR	5.1K-5-14
024	1	21-80384853	CAPACITOR	01UF-5-100	C 096	1	23-80296400	CAPACITOR	100UF-25V	G 022	1	65124486	RESISTOR	5.1K-5-14
025	1	21-80384853	CAPACITOR	01UF-5-100	C 097	1	23-80296400	CAPACITOR	100UF-25V	G 023	1	65124486	RESISTOR	5.1K-5-14
026	1	21-80384853	CAPACITOR	01UF-5-100	C 098	1	23-80296400	CAPACITOR	100UF-25V	G 024	1	65124486	RESISTOR	5.1K-5-14
027	1	21-80384853	CAPACITOR	01UF-5-100	C 099	1	23-80296400	CAPACITOR	100UF-25V	G 025	1	65124486	RESISTOR	5.1K-5-14
028	1	21-80384853	CAPACITOR	01UF-5-100	C 100	1	23-80296400	CAPACITOR	100UF-25V	G 026	1	65124486	RESISTOR	5.1K-5-14
029	1	21-80384853	CAPACITOR	01UF-5-100	C 101	1	21-80384842	CAPACITOR	1UF-20-100	G 027	501	65124489	RESISTOR	47K-5-14
030	1	21-80384853	CAPACITOR	01UF-20-100	C 102	1	21-80384842	CAPACITOR	1UF-20-100	G 028	501	65124489	RESISTOR	47K-5-14
031	1	21-80384853	CAPACITOR	01UF-20-100	C 103	1	21-80384842	CAPACITOR	1UF-20-100	G 029	501	65124489	RESISTOR	47K-5-14
032	1	21-80384853	CAPACITOR	01UF-20-100	C 104	1	21-80384842	CAPACITOR	1UF-20-100	G 030	501	65124489	RESISTOR	47K-5-14
033	1	21-80384853	CAPACITOR	01UF-20-100	C 105	1	21-80384842	CAPACITOR	1UF-20-100	G 031	501	65124489	RESISTOR	47K-5-14
034	1	21-80384853	CAPACITOR	01UF-20-100	C 106	1	21-80384842	CAPACITOR	1UF-20-100	G 032	501	65124489	RESISTOR	47K-5-14
035	1	21-80384853	CAPACITOR	01UF-20-100	C 107	1	21-80384842	CAPACITOR	1UF-20-100	G 033	501	65124489	RESISTOR	47K-5-14
036	1	21-80384853	CAPACITOR	01UF-20-100	C 108	1	21-80384842	CAPACITOR	1UF-20-100	G 034	501	65124489	RESISTOR	47K-5-14
037	1	21-80384853	CAPACITOR	01UF-20-100	C 109	1	21-80384842	CAPACITOR	1UF-20-100	G 035	501	65124489	RESISTOR	47K-5-14
038	1	21-80384853	CAPACITOR	01UF-20-100	C 110	1	21-80384842	CAPACITOR	1UF-20-100	G 036	501	65124489	RESISTOR	47K-5-14
039	1	21-80384853	CAPACITOR	01UF-20-100	C 111	1	21-80384842	CAPACITOR	1UF-20-100	G 037	501	65124489	RESISTOR	47K-5-14
040	1	21-80384853	CAPACITOR	01UF-20-100	C 112	1	21-80384842	CAPACITOR	1UF-20-100	G 038	501	65124489	RESISTOR	47K-5-14
041	1	21-80384853	CAPACITOR	01UF-20-100	C 113	1	21-80384842	CAPACITOR	1UF-20-100	G 039	501	65124489	RESISTOR	47K-5-14
042	1	21-80384853	CAPACITOR	01UF-20-100	C 114	1	21-80384842	CAPACITOR	1UF-20-100	G 040	501	65124489	RESISTOR	47K-5-14
043	1	21-80384853	CAPACITOR	01UF-20-100	C 115	1	21-80384842	CAPACITOR	1UF-20-100	G 041	501	65124489	RESISTOR	47K-5-14
044	1	21-80384853	CAPACITOR	01UF-20-100	C 116	1	21-80384842	CAPACITOR	1UF-20-100	G 042	501	65124489	RESISTOR	47K-5-14
045	1	21-80384853	CAPACITOR	01UF-20-100	C 117	1	21-80384842	CAPACITOR	1UF-20-100	G 043	501	65124489	RESISTOR	47K-5-14
046	1	21-80384853	CAPACITOR	01UF-20-100	C 118	1	21-80384842	CAPACITOR	1UF-20-100	G 044	501	65124489	RESISTOR	47K-5-14
047	1	21-80384853	CAPACITOR	01UF-20-100	C 119	1	21-80384842	CAPACITOR	1UF-20-100	G 045	501	65124489	RESISTOR	47K-5-14
048	1	21-80384853	CAPACITOR	01UF-20-100	C 120	1	21-80384842	CAPACITOR	1UF-20-100	G 046	501	65124489	RESISTOR	47K-5-14
049	1	21-80384853	CAPACITOR	01UF-20-100	C 121	1	21-80384842	CAPACITOR	1UF-20-100	G 047	501	65124489	RESISTOR	47K-5-14
050	1	21-80384853	CAPACITOR	01UF-20-100	C 122	1	21-80384842	CAPACITOR	1UF-20-100	G 048	501	65124489	RESISTOR	47K-5-14
051	1	21-80384853	CAPACITOR	01UF-20-100	C 123	1	21-80384842	CAPACITOR	1UF-20-100	G 049	501	65124489	RESISTOR	47K-5-14
052	1	21-80384853	CAPACITOR	01UF-20-100	C 124	1	21-80384842	CAPACITOR	1UF-20-100	G 050	501	65124489	RESISTOR	47K-5-14
053	1	21-80384853	CAPACITOR	01UF-20-100	C 125	1	21-80384842	CAPACITOR	1UF-20-100	G 051	501	65124489	RESISTOR	47K-5-14
054	1	21-80384853	CAPACITOR	01UF-20-100	C 126	1	21-80384842	CAPACITOR	1UF-20-100	G 052	501	65124489	RESISTOR	47K-5-14
055	1	21-80384853	CAPACITOR	01UF-20-100	C 127	1	21-80384842	CAPACITOR	1UF-20-100	G 053	501	65124489	RESISTOR	47K-5-14
056	1	21-80384853	CAPACITOR	01UF-20-100	C 128	1	21-80384842	CAPACITOR	1UF-20-100	G 054	501	65124489	RESISTOR	47K-5-14
057	1	21-80384853	CAPACITOR	01UF-20-100	C 129	1	21-80384842	CAPACITOR	1UF-20-100	G 055	501	65124489	RESISTOR	47K-5-14
058	1	21-80384853	CAPACITOR	01UF-20-100	C 130	1	21-80384842	CAPACITOR	1UF-20-100	G 056	501	65124489	RESISTOR	47K-5-14
059	1	21-80384853	CAPACITOR	01UF-20-100	C 131	1	21-80384842	CAPACITOR	1UF-20-100	G 057	501	65124489	RESISTOR	47K-5-14
060	1	21-80384853	CAPACITOR	01UF-20-100	C 132	1	21-80384842	CAPACITOR	1UF-20-100	G 058	501	65124489	RESISTOR	47K-5-14
061	1	21-80384853	CAPACITOR	01UF-20-100	C 133	1	21-80384842	CAPACITOR	1UF-20-100	G 059	501	65124489	RESISTOR	47K-5-14
062	1	21-80384853	CAPACITOR	01UF-20-100	C 134	1	21-80384842	CAPACITOR	1UF-20-100	G 060	501	65124489	RESISTOR	47K-5-14
063	1	21-80384853	CAPACITOR	01UF-20-100	C 135	1	21-80384842	CAPACITOR	1UF-20-100	G 061	501	65124489	RESISTOR	47K-5-14
064	1	21-80384853	CAPACITOR	01UF-20-100	C 136	1	21-80384842	CAPACITOR	1UF-20-100	G 062	501	65124489	RESISTOR	47K-5-14
065	1	21-80384853	CAPACITOR	01UF-20-100	C 137	1	21-80384842	CAPACITOR	1UF-20-100	G 063	501	65124489	RESISTOR	47K-5-14
066	1	21-80384853	CAPACITOR	01UF-20-100	C 138	1	21-80384842	CAPACITOR	1UF-20-100	G 064	501	65124489	RESISTOR	47K-5-14
067	1	21-80384853	CAPACITOR	01UF-20-100	C 139	1	21-80384842	CAPACITOR	1UF-20-100	G 065	501	65124489	RESISTOR	47K-5-14
068	1	21-80384853	CAPACITOR	01UF-20-100	C 140	1	21-80384842	CAPACITOR	1UF-20-100	G 066	501	65124489	RESISTOR	47K-5-14
069	1	21-80384853	CAPACITOR	01UF-20-100	C 141	1	21-80384842	CAPACITOR	1UF-20-100	G 067	501	65124489	RESISTOR	47K-5-14

SECTION 10 RECEIVER (A4)

10-1. General. The Receiver down converts the 10.7 MHz first IF signal to 455 kHz. Following the down conversion a linear or a logarithmic IF amplifier provide the gain prior to AM and FM detectors or the spectrum analyzer detector respectively. Post detection filtering provides the wide or narrow band responses for the audio outputs. The audio amplifier for the speaker and the alarm generator are also contained on this module. A block diagram of the Receiver is shown in figure 10-1 and its schematic in figure 10-2.

10-2. Down Converter. The 10.7 MHz IF signal is converted to 455 kHz by mixing with a 10.245 MHz local oscillator. The local oscillator is phase locked to the system 10 MHz frequency standard. A sample of the 10.245 MHz VCO signal is output to the Processor I/O module. There the VCO signal is mixed with 10 MHz, the difference is divided by 49, and the result compared with a 5 kHz reference obtained from the 10 MHz. Any frequency difference causes a correction to be made to the VCO frequency via the 10.245 MHz VCO TV line through the Loop Filter.

10-3. The IF filter following the mixer provides the selectivity for the system. Two bandwidths, ± 100 kHz wideband and ± 13 kHz narrowband, are processor selectable to correspond the front panel bandwidth control.

10-4. Linear IF Amplifier and Detectors. The linear IF Amplifier amplifies the 455 kHz signal to the AM and FM detectors. The DC signal from the AM detector is fed to the AGC Amplifier and Squelch Detection circuitry. There it is compared to the AGC reference with the resulting AGC signal controlling the gain of the IF Amplifier. For signal present indication and squelch operation the SQUELCH LVL from the front panel is compared to the AGC voltage. When the AGC voltage falls below the squelch level, indicating a strong signal, the SIG PRESENT line is activated. With the SIG PRESENT active the audio is allowed through the select switch and the signal present light on the front panel is illuminated. To warn the operator when the IF input level is beyond the linear range of the IF amplifier, the AGC voltage is also compared to a fixed IF overload level. When this level is exceeded, the IF OVLD line is activated causing the processor to flash the warning on the CRT display.

10-5. The AC component from the AM detector is buffered by the Audio Buffer and then passed to the Audio Select switch. The lower 3 dB corner on the AM audio response is approximately 100 Hz.

10-6. Frequency modulation is recovered by a dual bandwidth phase locked loop discriminator. The bandwidth, wide or narrow, is selected coincident with the IF Filter bandwidth. Audio from the discriminator is applied to the Audio Select switch.

10-7. A 455 kHz Buffer amplifier provides an interface between the IF Amplifier output and the IF processing circuits on the Scope/DVM Control module.

10-8. Audio Switching and Filtering. The output of the AM or FM detector or the SSB AUDIO signal from the Scope/DVM Control module can be selected as the demodulated audio output. Selection is made by the processor depending on the operating mode and the presence of the active state on the SIG PRESENT line. If the SIG PRESENT line is not active, the Audio Select switch is opened squelching the audio signal.

10-9. The Audio Filter provides either wide or narrow band filtering on the recovered audio. For wideband a 0.5 dB bandwidth of 100 kHz is provided while narrowband has a 0.5 dB bandwidth of 3 kHz. The output of the filter is separately buffered to three signal lines. The DEMOD CAL AUD signal is used on the Scope/DVM Control module for modulation determination, the DEMOD OUT signal goes to the front panel jack, and the VOL CNTL AUD provides the drive to the speaker audio amplifier.

10-10. Logarithmic Amplifier and Detector. For the spectrum analyzer function the logarithmic IF amplifier processes the input signal level over an 80 dB range. The Amplifier is composed of four 20 dB sections summed together. Amplitude detection at the output of the amplifier provides the SPECT ANA VERT signal to the Scope/DVM Control module.

10-11. Alarm Generator and Audio Amplifier. An astable multivibrator operating at 1.2 kHz is the Alarm Generator. The Alarm signal is controlled by the processor and is summed with the VOL CNTL AUD RTN signal at the input of the Audio Amplifier. The SPKR AUD output of the amplifier has 0.5 watt capability and is connected directly to the system speaker.

10-12. Module Control. Address decoding for the two control latches on this module is performed on the Synthesizer module. The two decoded lines, RF LCH ADD 13 and RF LCH ADD 14, determine which Control Latch the four bit data bus, RF DATA BUS 0-3, will be stored.

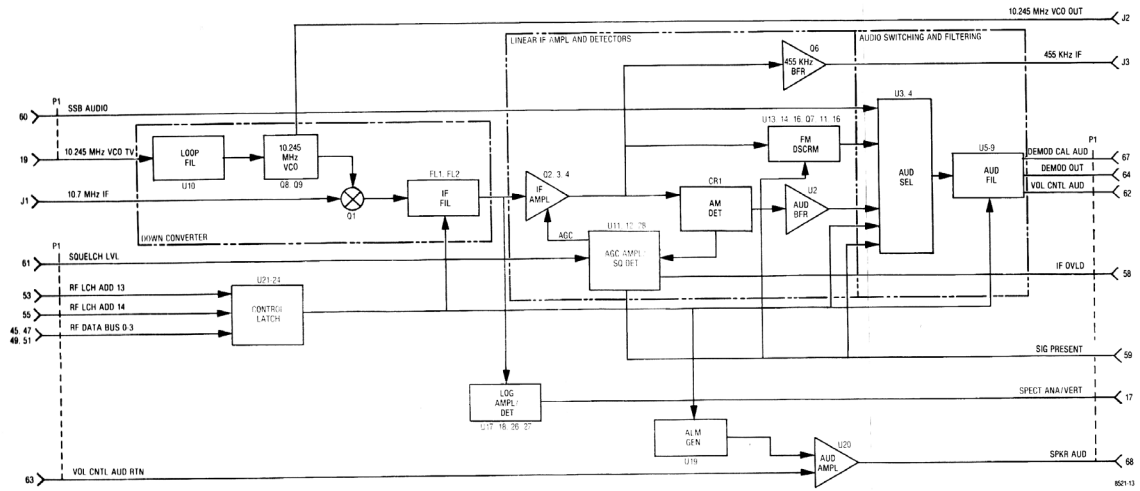

Figure 10-1. Receiver A4 Block Diagram

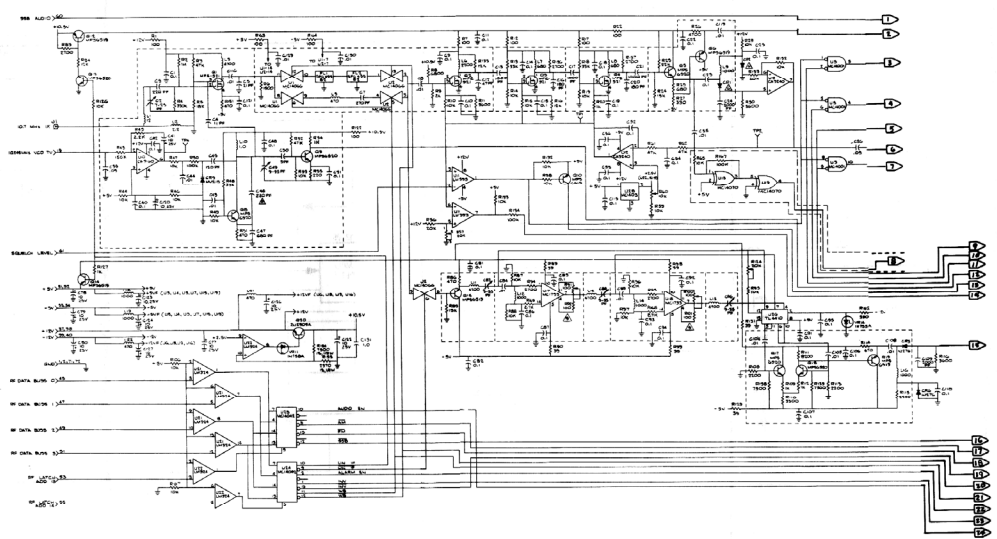

Figure 10-2. Receiver A4 Schematic Diagram (Sheet 1 of 2)

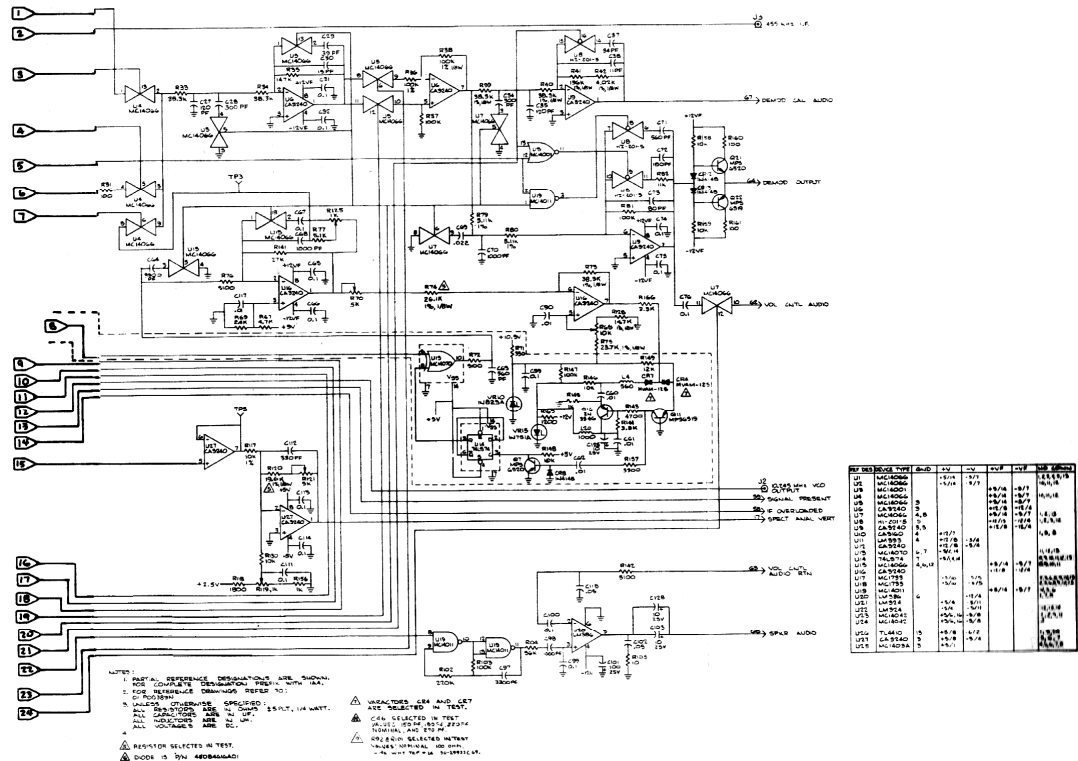

Figure 10-2. Receiver A4 Schematic Diagram (Sheet 2 of 2)

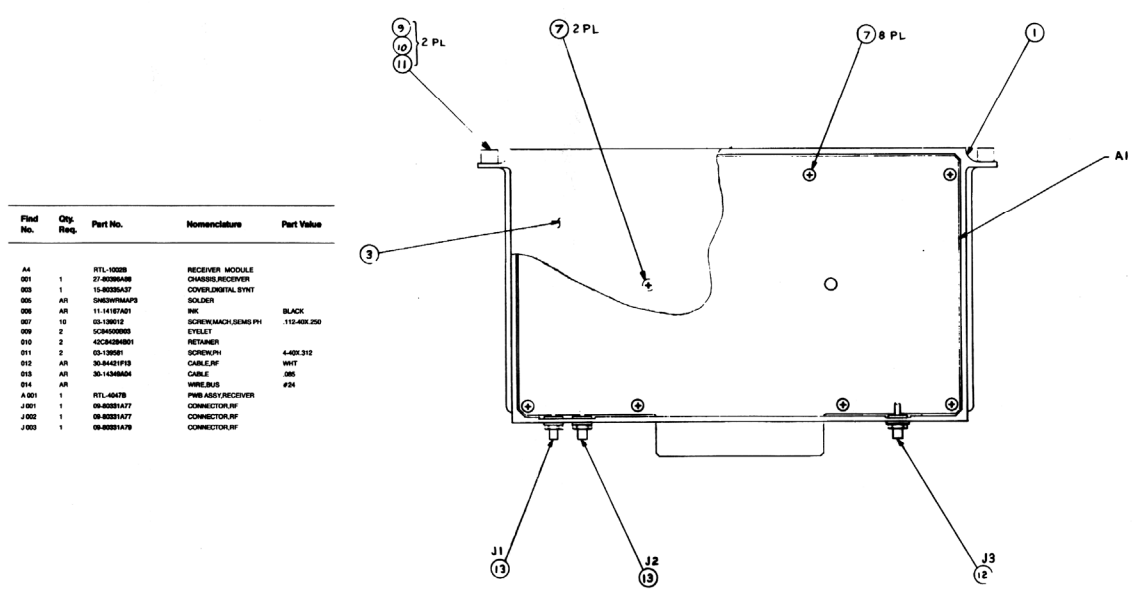

Figure 10-3. Receiver A4 (RTL-10002B) Parts Location Diagram

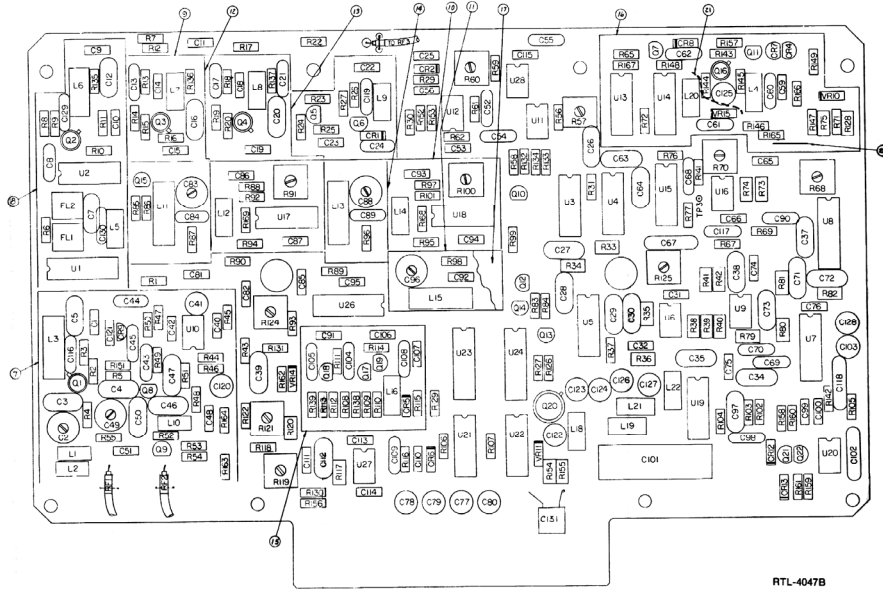

Figure 10-4. Receiver A4 PWB Parts
Location Diagram
(Sheet 1 of 3)

Find No.	Qty. Req.	Part No.	Nomenclature	Part Value	Find No.	Qty. Req.	Part No.	Nomenclature	Part Value	Find No.	Qty. Req.	Part No.	Nomenclature	Part Value
001	1	84-8033A23	FIBER RECEIVER		C 004	1	21-8033A49	CAPACITOR	1UF 20-16	C 125	1	23-8036A40	CAPACITOR	10UF 25V
005	AR	5N63WFP	SOLEID		C 055	1	21-8036A52	CAPACITOR	01UF 20-80-200	C 136	1	23-8036A40	CAPACITOR	10UF 25V
006	AR	11-14167A1	INK	BLACK	C 059	1	21-8036A49	CAPACITOR	1UF 20-100	C 127	1	23-8036A40	CAPACITOR	10UF 25V
007	1	26-P0067N001	SHIELD		C 059	1	21-8036A49	CAPACITOR	1UF 20-100	C 128	1	23-8036A40	CAPACITOR	10UF 25V
008	1	26-P0067N002	SHIELD		C 060	1	21-8036A52	CAPACITOR	01UF 20-80-200	C 129	1	21-8036A52	CAPACITOR	01UF 20-80-200
009	1	26-P0067N003	SHIELD		C 061	1	21-8036A52	CAPACITOR	01UF 20-80-200	C 130	1	21-8036A52	CAPACITOR	01UF 20-80-200
010	1	26-P0067N004	SHIELD		C 062	1	21-8036A52	CAPACITOR	01UF 20-80-200	C 131	1	23-8036A39	CAPACITOR	1UF 20-50
011	1	26-P0067N005	SHIELD		C 063	1	21-8036A50	CAPACITOR	560PF 10-500	C 131	1	48-8041A401	DIODE	
012	1	26-P0067N006	SHIELD		C 064	1	21D8-28810	CAPACITOR	300PF 15-100	C 002	1	48-8041A401	DIODE	
013	1	26-P0067N007	SHIELD		C 065	1	21-8036A49	CAPACITOR	1UF 20-100	C 004	501	48-8036A20	VARACTOR	MWAM-125 SCREENED
014	1	26-P0067N008	SHIELD		C 066	1	21-8036A49	CAPACITOR	1UF 20-100	C 004	501	48-8036A20	VARACTOR	MWAM-125 SCREENED
015	1	26-P0067N009	SHIELD		C 067	1	21-8036A05	CAPACITOR	1UF 20-100	C 004	501	48-8036A20	VARACTOR	MWAM-125 SCREENED
016	1	26-P0067N010	SHIELD		C 068	1	21-8036A51	CAPACITOR	1000PF 10-100	C 004	501	48-8036A20	VARACTOR	MWAM-125 SCREENED
017	1	26-P0067N011	SHIELD		C 069	1	21-8036A04	CAPACITOR	002UF 10-100	C 005	1	48-8316Z09	DIODE	
021	AR		WIRE TEF	#24 WHI	C 070	1	21-8036A51	CAPACITOR	1000PF 10-100	C 006	1	48-8316Z09	DIODE	
022	AR		WIRE SILD BUS	#24	C 071	1	21-8036A50	CAPACITOR	560PF 10-100	C 007	501	48-8036A20	VARACTOR	MWAM-125 SCREENED
C 081	1	21-8036A49	CAPACITOR	1UF 20-100	C 072	1	21D8-1448A6	CAPACITOR	80PF 5-500	C 007	501	48-8036A20	VARACTOR	MWAM-125 SCREENED
C 082	1	20-8036A56	CAPACITOR	7FD 25PF 200	C 073	1	21D8-12821	CAPACITOR	80PF 5-500	C 007	501	48-8036A20	VARACTOR	MWAM-125 SCREENED
C 083	1	21-8036A52	CAPACITOR	01UF 20-80-200	C 074	1	21-8036A49	CAPACITOR	1UF 20-100	C 007	501	48-8036A20	VARACTOR	MWAM-125 SCREENED
C 084	1	21D8-4948Z7	CAPACITOR	11PF 5-500	C 075	1	21-8036A49	CAPACITOR	1UF 20-100	C 008	1	48-8442K02	DIODE	
C 085	1	21D8-4948Z8	CAPACITOR	21PF 5-500	C 076	1	21-8036A49	CAPACITOR	1UF 20-100	C 009	1	48-8041A401	DIODE	
C 086	1	21D8-4948Z9	CAPACITOR	23PF 5-500	C 077	1	23-8036A40	CAPACITOR	10UF 25V	C 010	1	48-8442K02	DIODE	
C 088	1	21-8036A52	CAPACITOR	01UF 20-80-200	C 078	1	23-8036A40	CAPACITOR	10UF 25V	C 011	1	48-8442K02	DIODE	
C 089	1	21-8036A49	CAPACITOR	1UF 20-100	C 079	1	23-8036A40	CAPACITOR	10UF 25V	C 012	1	48-8036A30	FILTER CERAMIC	
C 090	1	21-8036A49	CAPACITOR	1UF 20-100	C 080	1	23-8036A40	CAPACITOR	10UF 25V	C 013	1	48-8036A30	FILTER CERAMIC	
C 091	1	21-8036A49	CAPACITOR	1UF 20-100	C 081	1	23-8036A40	CAPACITOR	10UF 25V	L 001	1	24-8036A30	COIL	12PH
C 092	1	21-8036A49	CAPACITOR	1UF 20-100	C 082	1	23-8036A40	CAPACITOR	10UF 25V	L 002	1	24-8036A30	COIL	2.2UH
C 093	1	21-8036A49	CAPACITOR	1UF 20-100	C 083	1	20-8036A57	CAPACITOR	8 TD 35PF 200	L 003	1	24-8036A44	COIL	4700UH
C 094	1	21D8-4948Z4	CAPACITOR	47PF 5-500	C 084	1	21-8036A52	CAPACITOR	01UF 20-80-200	L 004	1	24-8036A40	COIL	960UH
C 095	1	21-8036A51	CAPACITOR	1UF 20-100	C 085	1	21-8036A49	CAPACITOR	1UF 20-100	L 005	1	24-8036A40	COIL	470UH
C 096	1	21-8036A49	CAPACITOR	1UF 20-100	C 086	1	21-8036A49	CAPACITOR	1UF 20-100	L 006	1	21-8036A43	COIL	2000UH
C 097	1	21-8036A49	CAPACITOR	1UF 20-100	C 087	1	21-8036A49	CAPACITOR	1UF 20-100	L 007	1	24-8036A41	COIL	680UH
C 098	1	21-8036A49	CAPACITOR	1UF 20-100	C 088	1	21-8036A49	CAPACITOR	1UF 20-100	L 008	1	24-8036A41	COIL	680UH
C 099	1	21-8036A49	CAPACITOR	1UF 20-100	C 089	1	21-8036A49	CAPACITOR	1UF 20-100	L 009	1	24-8036A42	COIL	1000UH
C 100	1	21-8036A49	CAPACITOR	1UF 20-100	C 090	1	21-8036A52	CAPACITOR	01UF 20-80-200	L 010	1	24-8036A42	COIL	1000UH
C 101	1	21-8036A49	CAPACITOR	1UF 20-100	C 091	1	21-8036A49	CAPACITOR	1UF 20-100	L 011	1	24-8036A42	COIL	1000UH
C 102	1	21-8036A49	CAPACITOR	1UF 20-100	C 092	1	21-8036A49	CAPACITOR	1UF 20-100	L 012	1	24-8036A42	COIL	1000UH
C 103	1	21-8036A49	CAPACITOR	1UF 20-100	C 093	1	21-8036A49	CAPACITOR	1UF 20-100	L 013	1	24-8036A44	COIL	1700UH
C 104	1	21-8036A49	CAPACITOR	1UF 20-100	C 094	1	21-8036A49	CAPACITOR	1UF 20-100	L 014	1	24-8036A42	COIL	1000UH
C 105	1	21-8036A49	CAPACITOR	1UF 20-100	C 095	1	21-8036A49	CAPACITOR	1UF 20-100	L 015	1	24-8036A44	COIL	4700UH
C 106	1	21-8036A49	CAPACITOR	1UF 20-100	C 096	1	20-8036A57	CAPACITOR	8 TD 35PF 200	L 016	1	24-8036A42	COIL	1000UH
C 107	1	21D8-4948Z6	CAPACITOR	100PF 5-500	C 097	1	21D8-4948Z10	CAPACITOR	300PF 10-100	L 018	1	24-8036A42	COIL	1000UH
C 108	1	21D8-4948Z5	CAPACITOR	100PF 5-500	C 098	1	21-8036A51	CAPACITOR	1000PF 10-100	L 019	1	24-8036A42	COIL	1000UH
C 109	1	21D8-4948Z3	CAPACITOR	100PF 5-500	C 099	1	21-8036A49	CAPACITOR	1UF 20-100	L 020	1	24-8036A42	COIL	1000UH
C 110	1	21-8036A49	CAPACITOR	1UF 20-100	C 100	1	21-8036A49	CAPACITOR	1UF 20-100	L 021	1	24-8036A42	COIL	470UH
C 111	1	21-8036A49	CAPACITOR	1UF 20-100	C 101	1	20-8036A42	CAPACITOR	100PF 5-500	C 001	1	48-8036A42	TRANSISTOR	
C 112	1	21-8036A49	CAPACITOR	1UF 20-100	C 102	1	21C8237Z-10	CAPACITOR	05UF 20-25	C 001	1	48-8036A42	TRANSISTOR	
C 113	1	21-8036A49	CAPACITOR	1UF 20-100	C 103	1	21-8036A43	CAPACITOR	10UF 25V	C 002	1	48-8036A42	TRANSISTOR	
C 114	1	21-8036A49	CAPACITOR	1UF 20-100	C 104	1	21-8036A52	CAPACITOR	01UF 20-80-200	C 003	1	48-8036A42	TRANSISTOR	
C 115	1	21-8036A49	CAPACITOR	1UF 20-100	C 105	1	21-8036A52	CAPACITOR	01UF 20-80-200	C 004	1	48-8036A42	TRANSISTOR	
C 116	1	21-8036A49	CAPACITOR	1UF 20-100	C 106	1	21-8036A49	CAPACITOR	1UF 20-100	C 005	1	48-8036A49	TRANSISTOR	MPF5620 SCREENED
C 117	1	21-8036A49	CAPACITOR	1UF 20-100	C 107	1	21-8036A49	CAPACITOR	1UF 20-100	C 006	1	48-8036A49	TRANSISTOR	MPF5619 SCREENED
C 118	1	21-8036A49	CAPACITOR	1UF 20-100	C 108	1	21-8036A52	CAPACITOR	01UF 20-80-200	C 007	1	48-8036A49	TRANSISTOR	MPF5630 SCREENED
C 119	1	21-8036A49	CAPACITOR	1UF 20-100	C 109	1	21D8-4948Z9	CAPACITOR	2000PF 10-200	C 008	1	48-8036A49	TRANSISTOR	MPF5630 SCREENED
C 120	1	21-8036A49	CAPACITOR	1UF 20-100	C 110	1	21-8036A49	CAPACITOR	1UF 20-100	C 009	1	48-8036A49	TRANSISTOR	MPF5630 SCREENED
C 121	1	21-8036A49	CAPACITOR	1UF 20-100	C 111	1	21-8036A49	CAPACITOR	1UF 20-100	C 010	1	48-8036A49	TRANSISTOR	MPF5630 SCREENED
C 122	1	21-8036A49	CAPACITOR	1UF 20-100	C 112	1	21-8036A49	CAPACITOR	1UF 20-100	C 011	1	48-8036A49	TRANSISTOR	MPF5619 SCREENED
C 123	1	21-8036A49	CAPACITOR	1UF 20-100	C 113	1	21-8036A49	CAPACITOR	1UF 20-100	C 012	1	48-8036A49	TRANSISTOR	MPF5619 SCREENED
C 124	1	21-8036A49	CAPACITOR	1UF 20-100	C 114	1	21-8036A49	CAPACITOR	1UF 20-100	C 013	1	48-8036A49	TRANSISTOR	MPF5619 SCREENED
C 125	1	21-8036A49	CAPACITOR	1UF 20-100	C 115	1	21-8036A49	CAPACITOR	1UF 20-100	C 014	1	48-8036A49	TRANSISTOR	MPF5619 SCREENED
C 126	1	21-8036A49	CAPACITOR	1UF 20-100	C 116	1	21-8036A49	CAPACITOR	1UF 20-100	C 015	1	48-8036A49	TRANSISTOR	MPF5619 SCREENED
C 127	1	21-8036A49	CAPACITOR	1UF 20-100	C 117	1	21-8036A49	CAPACITOR	1UF 20-100	C 016	1	48-8036A49	TRANSISTOR	MPF5619 SCREENED
C 128	1	21-8036A49	CAPACITOR	1UF 20-100	C 118	1	21-8036A49	CAPACITOR	1UF 20-100	C 017	1	48-8036A49	TRANSISTOR	MPF5619 SCREENED
C 129	1	21-8036A49	CAPACITOR	1UF 20-100	C 119	1	21-8036A49	CAPACITOR	1UF 20-100	C 018	1	48-8036A49	TRANSISTOR	MPF5619 SCREENED
C 130	1	21-8036A49	CAPACITOR	1UF 20-100	C 120	1	21-8036A49	CAPACITOR	1UF 20-100	C 019	1	48-8036A49	TRANSISTOR	MPF5619 SCREENED
C 131	1	21-8036A49	CAPACITOR	1UF 20-100	C 121	1	21-8036A49	CAPACITOR	1UF 20-100	C 020	1	48-8036A49	TRANSISTOR	MPF5619 SCREENED
C 132	1	21-8036A49	CAPACITOR	1UF 20-100	C 122	1	21-8036A49	CAPACITOR	1UF 20-100	C 021	1	48-8036A49	TRANSISTOR	MPF5619 SCREENED
C 133	1	21-8036A49	CAPACITOR	1UF 20-100	C 123	1	21-8036A49	CAPACITOR	1UF 20-100	C 022	1	48-8036A49	TRANSISTOR	MPF5619 SCREENED
C 134	1	21-8036A49	CAPACITOR	1UF 20-100	C 124	1	21-8036A49	CAPACITOR	1UF 20-100	C 023	1	48-8036A49	TRANSISTOR	MPF5619 SCREENED

Figure 10-4. Receiver A4PWB Parts
Location Diagram
(Sheet 2 of 3)

SECTION 11

RF SYNTHESIZER (A5)

11-1. General. The RF Synthesizer provides an RF signal source for the frequency range from 10 kHz to 1 GHz in 100 Hz steps. The output frequency is programmed by the processor through the RF control bus and is phase locked to the 10 MHz frequency standard. A reference divider in the module produces outputs of 500 kHz, 50 kHz, 5 kHz, 1 kHz, 100 Hz, and 50 Hz (SYNTH SWP SYNC) each having the same accuracy as the frequency standard. A block diagram of the RF Synthesizer is shown in figure 11-1 and its schematic is shown in figure 11-3.

11-2. Frequency Synthesis Scheme. Four phase locked loops are used to generate the output frequency; a 60.5 MHz loop, a 310-440 MHz loop, the 500 MHz-1000 MHz loop, and the 550 MHz loop. Two of these loops contain programmable dividers, controlled by the microprocessor for varying the frequency. The 310-440 MHz loop is controlled by the four most significant digits of the required frequency and operates in discrete 50 kHz increments. The 60.5 MHz loop is controlled by the three least significant digits of the required frequency and operates in discrete 50 Hz increments.

11-3. The output is derived from three sources, covering the ranges of 10 kHz to 250 MHz, 250 MHz to 500 MHz, and 500 MHz to 1000 MHz. In the first range, 10 kHz to 250 MHz, the output is derived by mixing the fixed 550 MHz signal with 500-1000 MHz signal programmed for frequencies from 550.01 MHz to 800 MHz. For the second range, 250 to 500 MHz, the output is a divide by two of the 500-1000 MHz signal. The final range is the 500-1000 MHz signal directly. The appropriate frequency source is switched to the SYNTH RF output of the Output Select switch.

11-4. A basic flow diagram for programming the RF Synthesizer is shown in figure 11-2. This diagram includes generate and monitor considerations, wideband amplifier control, and modulation control.

11-5. 310-440 MHz Phase Locked Loop. A single 310-440 MHz VCO is phase locked to the 100 kHz reference input using a straight forward loop. The VCO output is divided down to 50 kHz using a programmable two modulus prescaler and divider. Programming of the divider is controlled by the processor to give output frequencies from 310 to 440 MHz in 50 kHz steps.

11-6. 60.5 MHz Phase Locked Loop. The 60.5 MHz loop is programmable over a ± 100 kHz range in 50 Hz increments. The 60.5 MHz VCO output is mixed with a 50 MHz signal from the 550 MHz loop. A programmable divider following the mixer divides the $10.5 \text{ MHz} \pm 100 \text{ kHz}$ signal down to the 50 Hz reference frequency. A comparison between the divider output and the reference signal by the Phase/Frequency detector results in an error voltage to the VCO which maintains the phase lock.

11-7. 550 MHz Phase Locked Loop. A fixed frequency of 550 MHz is obtained by dividing the 550 MHz VCO by 55 to obtain 10 MHz. The 10 MHz from the divider is compared with the 10 MHz frequency standard in the Phase/Frequency Detector. The resulting error signal is filtered and used to correct the 550 MHz VCO to maintain it in lock.

11-8. A Voltage Controlled Attenuator (VCA) follows the 550 MHz output to level the generator output for frequencies below 1 MHz. The leveling loop in the RF input module provides the ALC VOLT control signal to maintain the required output level at the front panel RF jack. See paragraph 5-31 for a further description of output leveling.

11-9. 500-1000 MHz Phase Locked Loop. The 500-1000 MHz output is locked to either the sum or the difference of the 310-440 MHz and 60.5 MHz loop output frequencies. In the locked condition, mixing the divide by two output of the 500-1000 MHz VCO's with the 310-440 MHz signal gives a difference frequency equal to the 60.5 MHz output. There are two frequencies at the divide by two output, the 310-440 MHz frequency plus or minus the 60.5 frequency, which will mix down to the correct frequency. However, the sense of the loop is inverted for one compared to the other. Thus the phase switch following the Phase/Frequency Detector determines at which frequency the loop will lock.

11-10. Modulation Control. Modulation of the tuning voltage for the 60.5 MHz VCO provides the frequency modulation of the RF output. Since the modulation sensitivity changes by a factor of two when the 250-500 MHz source is selected, the modulation control provides programmable gain control to maintain constant sensitivity at the FM MOD and SWEEP inputs. Additionally, the wideband modulation mode requires a gain of four beyond that for the narrowband mode. Thus under the control of the processor the Modulation Control selects between the SWEEP and FM MOD inputs, provides gains of 1, 2, 4, and 8 for the FM MOD input and gains of 1 and 2 for the SWEEP input. Input modulation sensitivities are 5 kHz/volt and 20 kHz/volt for narrow and wideband FM input and 2 MHz/volt for the sweep input.

11-11. Module Control. Control information is latched in four bit control latches which are loaded by the processor through the RF control bus. The four bit RF ADD BUS 0-3 is decoded by the Address Decoder to determine which Control Latch the four bit RF DATA BUS 0-3 is to be stored. Synchronization of the data transfer is the function of the RF BUS EN line. Two decoded address outputs, RF LATCH 13 and 14, select latches on the receiver module for receiver control. One control latch output, LO/HI BAND SEL, goes to the RF Input module to control the frequency range of the output amplifier.

Find No.	Qty. Req.	Part No.	Nomenclature	Part Value
001	1	RTC-1001B	SYNTHESIZER	
002	1	27-809841	CHASSIS ENVIRONMENT	
003	1	15-803347	COVER/DIGITAL SVT	
004	4	RTS-00003	RYELET	
005	4	RTS-00003	RETAINER	
006	29	03-13884	SCHEMACH SEMS PH	112-403-312
007	AR	5HE2WRM4P3	WIRE	#24
008	AR	11-191201	WRE	BLACK
009	AR	15-803346	COVER RF SYNTHESIZ	
010	1	15-803346	SHIELD CAPACITOR	
011	1	64-8031068	PLATE/CONNECTOR	
012	1	64-8031068	WASHER/LOCK	4-403-312
013	4	03-13884	SCHEMACH SEMS PH	112
014	38	04-11603	WASHER/LOCK	112
015	19	03-13884	SCHEMACH SEMS PH	112-403-312
016	AR	30-1068429	CABLE	WHITE
017	19	03-13884	SCHEMACH SEMS PH	112-403-312
018	AR	30-1068429	CABLE	WHITE
019	AR	30-1068429	CABLE	WHITE
020	7	03-13884	SCHEMACH SEMS PH	112-403-312
021	1	28-1075491	TERMINAL	
022	AR	M20305-104-8	WIRE	#24
023	AR	M20305-103-9	INSULATION SLEEVE	283 WHT
024	AR	M20305-103-9	INSULATION SLEEVE	283 WHT
025	17	10-PT989V002	DIGITAL SVT/REFTOR	
026	2	10-PT989V002	SOLDER RING/REFTOR	
027	1	RTS-00008	RF SYNTHESIZER ASS	
028	1	RTS-00008	RF SYNTHESIZER ASS	
C 001	1	204-603-1V50022	CAPACITOR	500PF-20-80-200
C 002	1	204-603-1V50022	CAPACITOR	500PF-20-80-200
C 003	1	204-603-1V50022	CAPACITOR	500PF-20-80-200
C 004	1	204-603-1V50022	CAPACITOR	500PF-20-80-200
C 005	1	204-603-1V50022	CAPACITOR	500PF-20-80-200
C 006	1	204-603-1V50022	CAPACITOR	500PF-20-80-200
C 007	1	204-603-1V50022	CAPACITOR	500PF-20-80-200
C 008	1	204-603-1V50022	CAPACITOR	500PF-20-80-200
C 009	1	204-603-1V50022	CAPACITOR	500PF-20-80-200
C 010	1	204-603-1V50022	CAPACITOR	500PF-20-80-200
C 011	1	204-603-1V50022	CAPACITOR	500PF-20-80-200
C 012	1	204-603-1V50022	CAPACITOR	500PF-20-80-200
C 013	1	204-603-1V50022	CAPACITOR	500PF-20-80-200
C 014	1	204-603-1V50022	CAPACITOR	500PF-20-80-200
C 015	1	204-603-1V50022	CAPACITOR	500PF-20-80-200
C 016	1	204-603-1V50022	CAPACITOR	500PF-20-80-200
C 017	1	204-603-1V50022	CAPACITOR	500PF-20-80-200
C 018	1	204-603-1V50022	CAPACITOR	500PF-20-80-200
F 001	1	RT-800411	FILTER HP	1500-003
F 002	1	RT-800411	FILTER HP	1500-003
J 001	1	08-8031479	CONNECTOR HP	
L 001	1	09-8030437	COIL	100UH

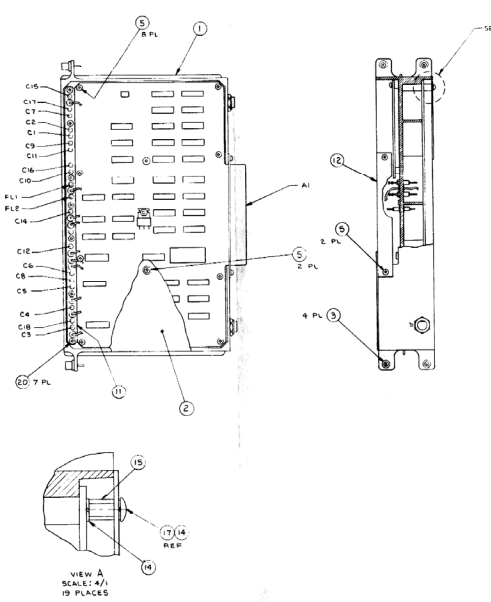

Figure 11-7. RF Synthesizer AS42 (RTC-4010B) Parts Location Diagram

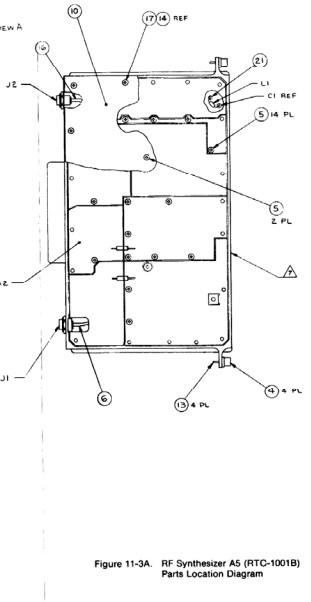
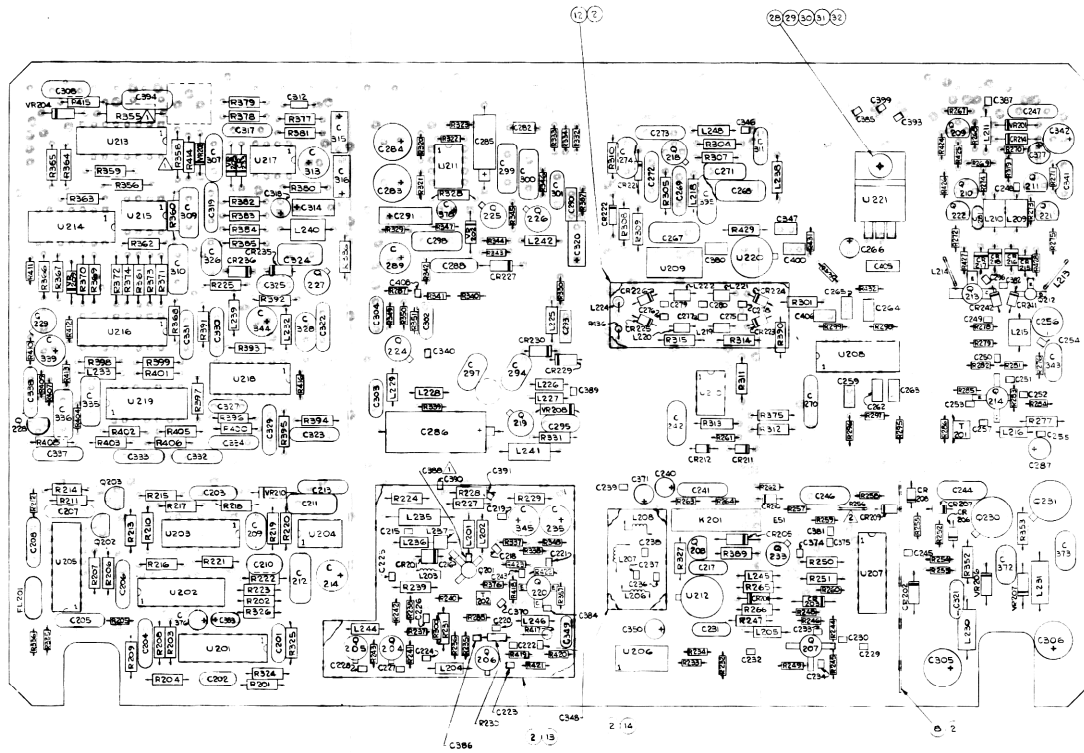

Figure 11-3A. RF Synthesizer AS5 (RTC-1001B) Parts Location Diagram

Find No.	Qty. Req.	Part No.	Nomenclature	Part Value
001	1	RTC-4010B	RF SYNTHESIZER	
002	AR	5HE2WRM4P3	SOLDER	BLACK
003	AR	11-191201	WRE	BLACK
004	AR	15-803346	COVER RF SYNTHESIZ	
005	1	64-8031068	SHIELD	
006	1	64-8031068	SHIELD	
007	1	64-8031068	SHIELD	
008	1	64-8031068	SHIELD	
009	1	64-8031068	SHIELD	
010	1	64-8031068	SHIELD	
011	AR	M20305-104-8	WIRE	#24
012	AR	M20305-103-9	INSULATION SLEEVE	283 WHT
013	AR	M20305-103-9	INSULATION SLEEVE	283 WHT
014	AR	M20305-103-9	INSULATION SLEEVE	283 WHT
015	AR	M20305-103-9	INSULATION SLEEVE	283 WHT
016	AR	M20305-103-9	INSULATION SLEEVE	283 WHT
017	AR	M20305-103-9	INSULATION SLEEVE	283 WHT
018	AR	M20305-103-9	INSULATION SLEEVE	283 WHT
019	AR	M20305-103-9	INSULATION SLEEVE	283 WHT
020	AR	M20305-103-9	INSULATION SLEEVE	283 WHT
021	AR	M20305-103-9	INSULATION SLEEVE	283 WHT
022	AR	M20305-103-9	INSULATION SLEEVE	283 WHT
023	AR	M20305-103-9	INSULATION SLEEVE	283 WHT
024	AR	M20305-103-9	INSULATION SLEEVE	283 WHT
025	AR	M20305-103-9	INSULATION SLEEVE	283 WHT
026	AR	M20305-103-9	INSULATION SLEEVE	283 WHT
027	AR	M20305-103-9	INSULATION SLEEVE	283 WHT
028	AR	M20305-103-9	INSULATION SLEEVE	283 WHT
029	AR	M20305-103-9	INSULATION SLEEVE	283 WHT
030	AR	M20305-103-9	INSULATION SLEEVE	283 WHT
031	AR	M20305-103-9	INSULATION SLEEVE	283 WHT
032	AR	M20305-103-9	INSULATION SLEEVE	283 WHT
033	AR	M20305-103-9	INSULATION SLEEVE	283 WHT
034	AR	M20305-103-9	INSULATION SLEEVE	283 WHT
035	AR	M20305-103-9	INSULATION SLEEVE	283 WHT
036	AR	M20305-103-9	INSULATION SLEEVE	283 WHT
037	AR	M20305-103-9	INSULATION SLEEVE	283 WHT
038	AR	M20305-103-9	INSULATION SLEEVE	283 WHT
039	AR	M20305-103-9	INSULATION SLEEVE	283 WHT
040	AR	M20305-103-9	INSULATION SLEEVE	283 WHT
041	AR	M20305-103-9	INSULATION SLEEVE	283 WHT
042	AR	M20305-103-9	INSULATION SLEEVE	283 WHT
043	AR	M20305-103-9	INSULATION SLEEVE	283 WHT
044	AR	M20305-103-9	INSULATION SLEEVE	283 WHT
045	AR	M20305-103-9	INSULATION SLEEVE	283 WHT
046	AR	M20305-103-9	INSULATION SLEEVE	283 WHT
047	AR	M20305-103-9	INSULATION SLEEVE	283 WHT
048	AR	M20305-103-9	INSULATION SLEEVE	283 WHT
049	AR	M20305-103-9	INSULATION SLEEVE	283 WHT
050	AR	M20305-103-9	INSULATION SLEEVE	283 WHT
051	AR	M20305-103-9	INSULATION SLEEVE	283 WHT
052	AR	M20305-103-9	INSULATION SLEEVE	283 WHT
053	AR	M20305-103-9	INSULATION SLEEVE	283 WHT
054	AR	M20305-103-9	INSULATION SLEEVE	283 WHT
055	AR	M20305-103-9	INSULATION SLEEVE	283 WHT
056	AR	M20305-103-9	INSULATION SLEEVE	283 WHT
057	AR	M20305-103-9	INSULATION SLEEVE	283 WHT
058	AR	M20305-103-9	INSULATION SLEEVE	283 WHT
059	AR	M20305-103-9	INSULATION SLEEVE	283 WHT
060	AR	M20305-103-9	INSULATION SLEEVE	283 WHT
061	AR	M20305-103-9	INSULATION SLEEVE	283 WHT
062	AR	M20305-103-9	INSULATION SLEEVE	283 WHT
063	AR	M20305-103-9	INSULATION SLEEVE	283 WHT
064	AR	M20305-103-9	INSULATION SLEEVE	283 WHT
065	AR	M20305-103-9	INSULATION SLEEVE	283 WHT
066	AR	M20305-103-9	INSULATION SLEEVE	283 WHT
067	AR	M20305-103-9	INSULATION SLEEVE	283 WHT
068	AR	M20305-103-9	INSULATION SLEEVE	283 WHT
069	AR	M20305-103-9	INSULATION SLEEVE	283 WHT
070	AR	M20305-103-9	INSULATION SLEEVE	283 WHT
071	AR	M20305-103-9	INSULATION SLEEVE	283 WHT
072	AR	M20305-103-9	INSULATION SLEEVE	283 WHT
073	AR	M20305-103-9	INSULATION SLEEVE	283 WHT
074	AR	M20305-103-9	INSULATION SLEEVE	283 WHT
075	AR	M20305-103-9	INSULATION SLEEVE	283 WHT
076	AR	M20305-103-9	INSULATION SLEEVE	283 WHT
077	AR	M20305-103-9	INSULATION SLEEVE	283 WHT
078	AR	M20305-103-9	INSULATION SLEEVE	283 WHT
079	AR	M20305-103-9	INSULATION SLEEVE	283 WHT
080	AR	M20305-103-9	INSULATION SLEEVE	283 WHT
081	AR	M20305-103-9	INSULATION SLEEVE	283 WHT
082	AR	M20305-103-9	INSULATION SLEEVE	283 WHT
083	AR	M20305-103-9	INSULATION SLEEVE	283 WHT
084	AR	M20305-103-9	INSULATION SLEEVE	283 WHT
085	AR	M20305-103-9	INSULATION SLEEVE	283 WHT
086	AR	M20305-103-9	INSULATION SLEEVE	283 WHT
087	AR	M20305-103-9	INSULATION SLEEVE	283 WHT
088	AR	M20305-103-9	INSULATION SLEEVE	283 WHT
089	AR	M20305-103-9	INSULATION SLEEVE	283 WHT
090	AR	M20305-103-9	INSULATION SLEEVE	283 WHT
091	AR	M20305-103-9	INSULATION SLEEVE	283 WHT
092	AR	M20305-103-9	INSULATION SLEEVE	283 WHT
093	AR	M20305-103-9	INSULATION SLEEVE	283 WHT
094	AR	M20305-103-9	INSULATION SLEEVE	283 WHT
095	AR	M20305-103-9	INSULATION SLEEVE	283 WHT
096	AR	M20305-103-9	INSULATION SLEEVE	283 WHT
097	AR	M20305-103-9	INSULATION SLEEVE	283 WHT
098	AR	M20305-103-9	INSULATION SLEEVE	283 WHT
099	AR	M20305-103-9	INSULATION SLEEVE	283 WHT
100	AR	M20305-103-9	INSULATION SLEEVE	283 WHT

Find No.	Qty. Req.	Part No.	Nomenclature	Part Value
C 236	1	21-8037010	CAPACITOR	10PF-5-100
C 237	1	21-8037014	CAPACITOR	22PF-5-100
C 238	1	21-8037014	CAPACITOR	22PF-5-100
C 239	1	21-8037010	CAPACITOR	10PF-5-100
C 240	1	2098341015	CAPACITOR	15UF-20-35
C 241	1	21-8036842	CAPACITOR	01UF-20-80-200
C 242	1	21-8036842	CAPACITOR	100PF-5-100
C 243	1	21-8037014	CAPACITOR	10PF-5-100
C 244	1	21-8036842	CAPACITOR	22PF-5-100
C 245	1	21-8037014	CAPACITOR	22PF-5-100
C 246	1	21-8036842	CAPACITOR	22PF-5-100
C 247	1	21-8036842	CAPACITOR	01UF-20-80-200
C 248	1	21-8037014	CAPACITOR	22PF-5-100
C 249	1	21-8037014	CAPACITOR	22PF-5-100
C 250	1	21-8037014	CAPACITOR	22PF-5-100
C 251	1	21-8037014	CAPACITOR	22PF-5-100
C 252	1	21-8037014	CAPACITOR	22PF-5-100
C 253	1	21-8037014	CAPACITOR	22PF-5-100
C 254	1	21-8037014	CAPACITOR	22PF-5-100
C 255	1	21-8037014	CAPACITOR	22PF-5-100
C 256	1	21-8037014	CAPACITOR	22PF-5-100
C 257	1	21-8037014	CAPACITOR	22PF-5-100
C 258	1	21-8037014	CAPACITOR	22PF-5-100
C 259	1	21-8037014	CAPACITOR	22PF-5-100
C 260	1	21-8037014	CAPACITOR	22PF-5-100
C 261	1	21-8037014	CAPACITOR	22PF-5-100
C 262	1	21-8037014	CAPACITOR	22PF-5-100
C 263	1	21-8037014	CAPACITOR	22PF-5-100
C 264	1	21-8037014	CAPACITOR	22PF-5-100
C 265	1	21-8037014	CAPACITOR	22PF-5-100
C 266	1	21-8037014	CAPACITOR	22PF-5-100
C 267	1	21-8037014	CAPACITOR	22PF-5-100
C 268	1	21-8037014	CAPACITOR	22PF-5-100
C 269	1	21-8037014	CAPACITOR	22PF-5-100
C 270	1	21-8037014	CAPACITOR	22PF-5-100
C 271	1	21-8037014	CAPACITOR	22PF-5-100
C 272	1	21-8037014	CAPACITOR	22PF-5-100
C 273	1	21-8037014	CAPACITOR	22PF-5-100
C 274	1	21-8037014	CAPACITOR	22PF-5-100
C 275	1	21-8037014	CAPACITOR	22PF-5-100
C 276	1	21-8037014	CAPACITOR	22PF-5-100
C 277	1	21-8037014	CAPACITOR	22PF-5-100
C 278	1	21-8037014	CAPACITOR	22PF-5-100
C 279	1	21-8037014	CAPACITOR	22PF-5-100
C 280	1	21-8037014	CAPACITOR	22PF-5-100
C 281	1	21-8037014	CAPACITOR	22PF-5-100
C 282	1	21-8037014	CAPACITOR	22PF-5-100
C 283	1	21-8037014	CAPACITOR	22PF-5-100
C 284	1	21-8037014	CAPACITOR	22PF-5-100
C 285	1	21-8037014	CAPACITOR	22PF-5-100
C 286	1	21-8037014	CAPACITOR	22PF-5-100
C 287	1	21-8037014	CAPACITOR	22PF-5-100
C 288	1	21-8037014	CAPACITOR	22PF-5-100
C 289	1	21-8037014	CAPACITOR	22PF-5-100
C 290	1	21-8037014	CAPACITOR	22PF-5-100
C 291	1	21-8037014	CAPACITOR	22PF-5-100
C 292	1	21-8037014	CAPACITOR	22PF-5-100
C 293	1	21-8037014	CAPACITOR	22PF-5-100
C 294	1	21-8037014	CAPACITOR	22PF-5-100
C 295	1	21-8037014	CAPACITOR	22PF-5-100
C 296	1	21-8037014	CAPACITOR	22PF-5-100
C 297	1	21-80370		



NOTES:
 1. VALUE OF COMPONENT TO BE
 SELECT IN TEST
 2. R266 IS SELECT IN TEST
 WITH NORMAL VALUE OF
 26 GA RES-WIDE

Figure 11-7. RF Synthesizer A5A2 (RTC-4010B)
 Parts Location Diagram

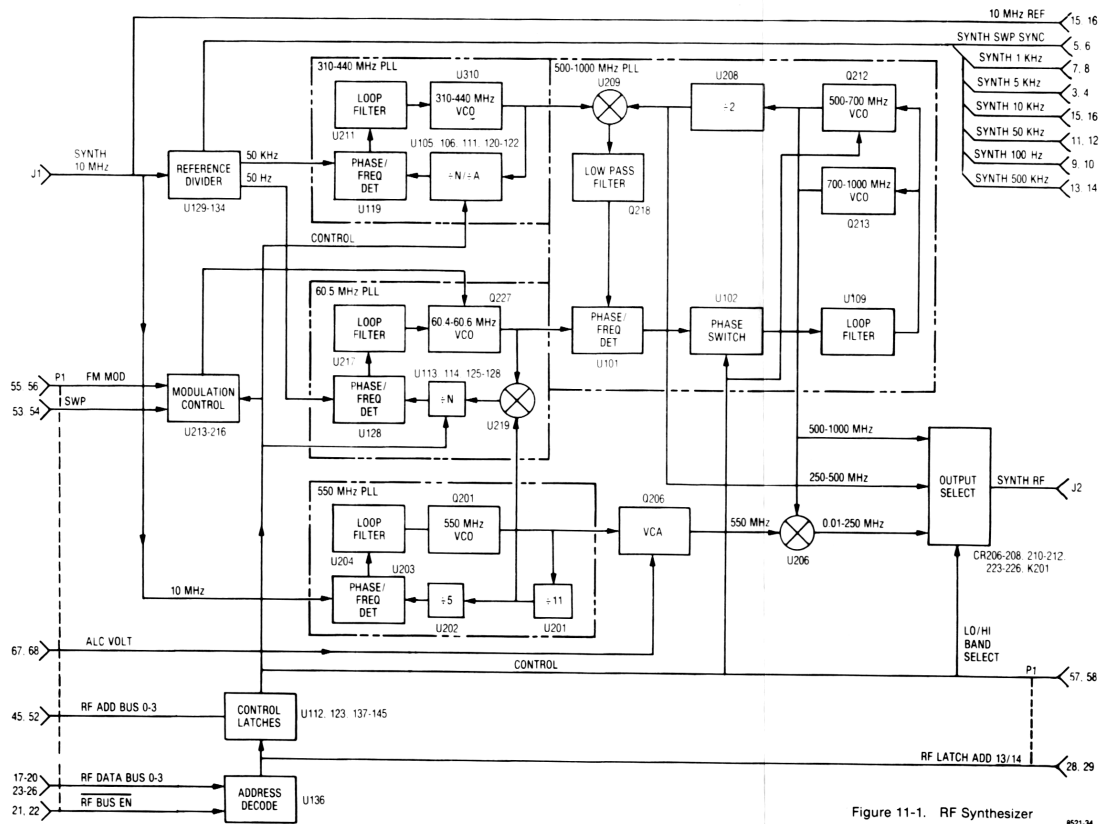

Figure 11-1. RF Synthesizer A5 Block Diagram

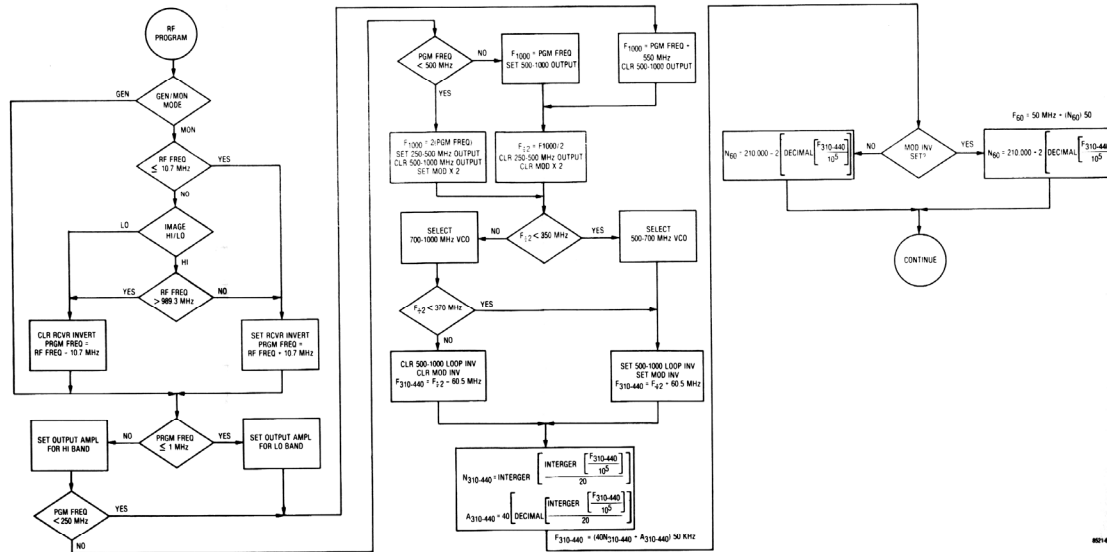

Figure 11-2. Frequency Programming Flow Diagram

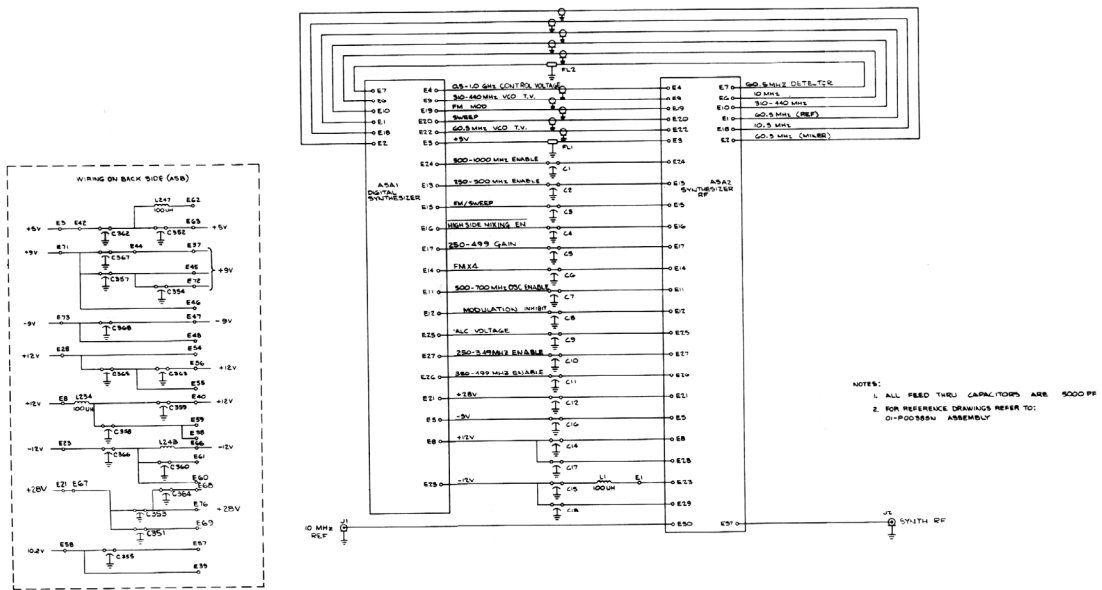

Figure 11-3. RF Synthesizer AS Schematic Diagram

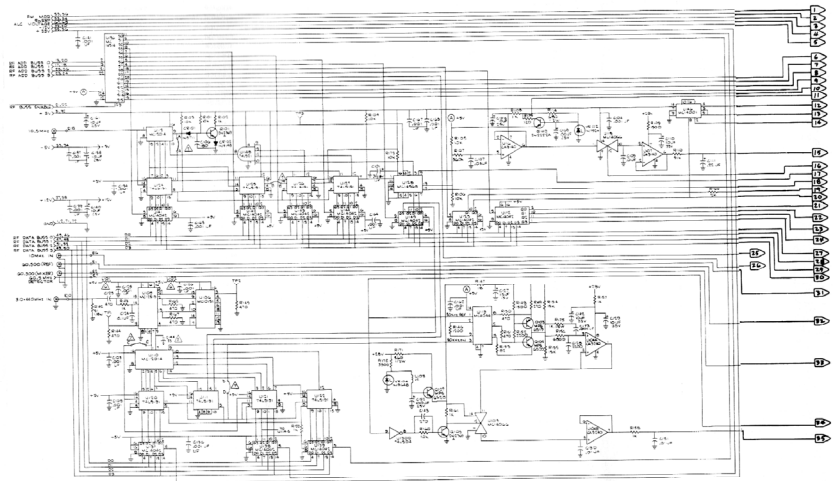

Figure 11-4. Digital Synthesizer A5A1 Schematic Diagram (Sheet 1 of 2)

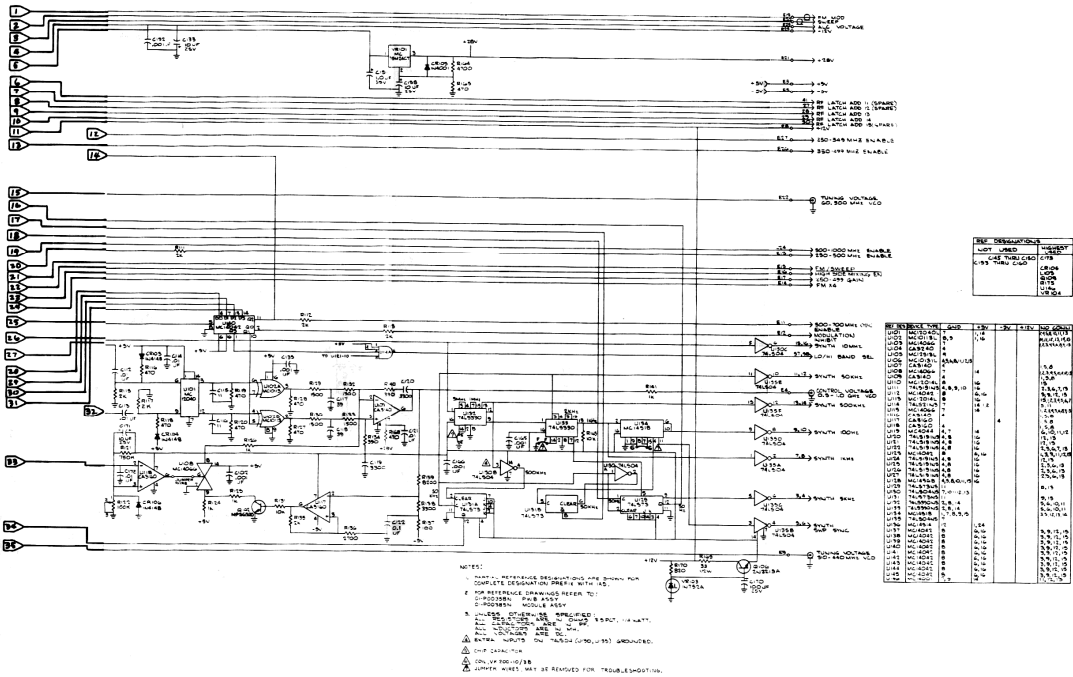

Figure 11-4. Digital Synthesizer A51 Schematic Diagram (Sheet 2 of 2)

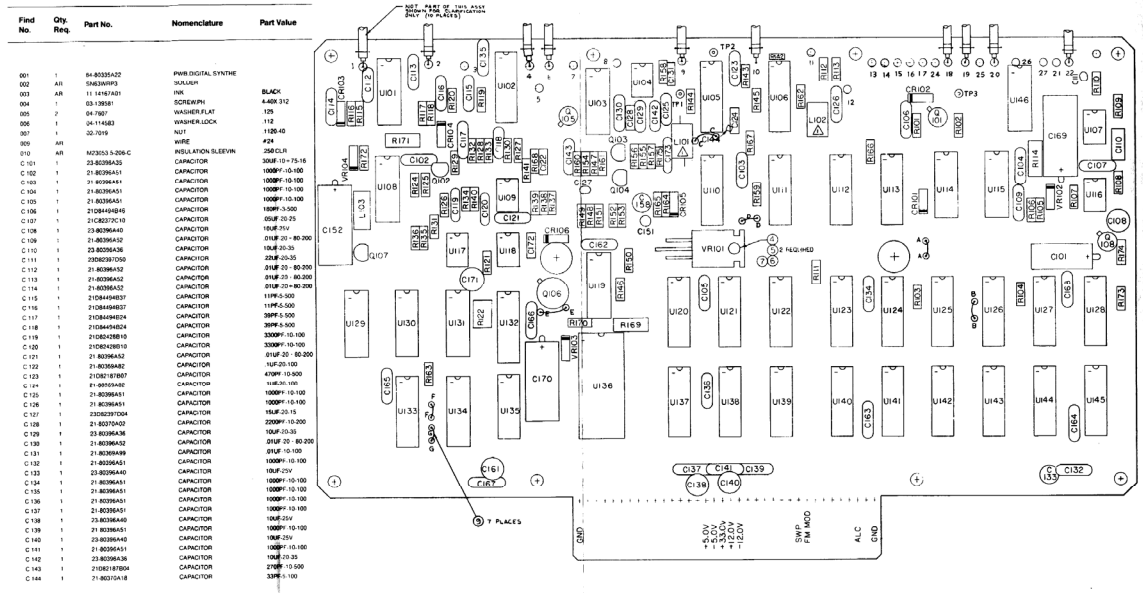

Figure 11-5. Digital Synthesizer A51 (RTC-4009B) Parts Location Diagram (Sheet 1 of 2)

Find No.	Qty Req.	Part No.	Nomenclature	Part Value	Find No.	Qty Req.	Part No.	Nomenclature	Part Value	Find No.	Qty Req.	Part No.	Nomenclature	Part Value
C 151	1	2308041013	CAPACITOR	10UF-20.35	R 121	1	6512A819	RESISTOR	750K-5.14	R 113	1	6512A48	RESISTOR	100K-5.14
C 152	1	230806510	CAPACITOR	100UF-25V	R 122	1	1808340219	RESISTOR VARIABLE	100K	U 101	1	518027A09	INTEGRATED CIRCUIT	MC12943 SCREENED
C 156	1	2308080440	CAPACITOR	10UF-25V	R 124	1	6512A449	RESISTOR	16K-5.14	U 102	1	518035B79	INTEGRATED CIRCUIT	MC12113 SCREENED
C 161	1	2308080440	CAPACITOR	10UF-25V	R 125	1	6512A449	RESISTOR	16K-5.14	U 103	1	518035B48	INTEGRATED CIRCUIT	MC14086PCP SCREENED
C 162	1	2180308A51	CAPACITOR	1000PF-10-100	R 126	1	6512A468	RESISTOR	16K-5.14	U 104	1	518035A54	INTEGRATED CIRCUIT	CA348E SCREENED
C 163	1	2180308A51	CAPACITOR	1000PF-10-100	R 127	1	6512A441	RESISTOR	47K-5.14	U 105	1	518035A13	INTEGRATED CIRCUIT	MC12513L SCREENED
C 164	1	2180308A51	CAPACITOR	1000PF-10-100	R 128	1	6512A441	RESISTOR	47K-5.14	U 106	1	518035L55	INTEGRATED CIRCUIT	MC1436E SCREENED
C 165	1	2180308A51	CAPACITOR	1000PF-10-100	R 129	1	6512A463	RESISTOR	15K-5.14	U 107	1	518035A21	INTEGRATED CIRCUIT	CA348E SCREENED
C 166	1	2180308A51	CAPACITOR	1000PF-10-100	R 130	1	6512A463	RESISTOR	15K-5.14	U 108	1	518038A48	INTEGRATED CIRCUIT	MC14086PCP SCREENED
C 167	1	2180308A51	CAPACITOR	1000PF-10-100	R 131	1	6512A473	RESISTOR	16K-5.14	U 109	1	518035A40	INTEGRATED CIRCUIT	CA348E SCREENED
C 168	1	2180308A51	CAPACITOR	1000PF-10-100	R 132	1	6512A463	RESISTOR	15K-5.14	U 110	1	518036A58	INTEGRATED CIRCUIT	MC1074L SCREENED
C 169	1	230806510	CAPACITOR	100UF-25V	R 133	1	6512A463	RESISTOR	15K-5.14	U 111	1	518036A74	INTEGRATED CIRCUIT	SN74LS19N SCREENED
C 170	1	230806510	CAPACITOR	100UF-25V	R 134	1	6512A459	RESISTOR	30K-5.14	U 112	1	518036A58	INTEGRATED CIRCUIT	MC14048E SCREENED
C 171	1	230806510	CAPACITOR	100UF-25V	R 135	1	6512A456	RESISTOR	2.0K-5.14	U 113	1	518036A58	INTEGRATED CIRCUIT	MC1074L SCREENED
C 172	1	2180308A51	CAPACITOR	01UF-10-100	R 136	1	6512A459	RESISTOR	2.7K-5.14	U 114	1	518036A18	INTEGRATED CIRCUIT	SN74LS24NS SCREENED
C 173	1	2180308A51	CAPACITOR	1000PF-10-100	R 137	1	6512A425	RESISTOR	100K-5.14	U 115	1	518038A48	INTEGRATED CIRCUIT	MC14086PCP SCREENED
CR101	1	4834418A01	DIODE		R 138	1	6512A461	RESISTOR	3.3K-5.14	U 116	1	518035A01	INTEGRATED CIRCUIT	CA348E SCREENED
CR102	1	4834430J02	DIODE		R 139	1	6512A401	RESISTOR	8.2K-5.14	U 117	1	518035A02	INTEGRATED CIRCUIT	CA348E SCREENED
CR103	1	4834430J02	DIODE		R 140	1	6512A420	RESISTOR	30K-5.14	U 118	1	518035A02	INTEGRATED CIRCUIT	CA348E SCREENED
CR104	1	4834430J02	DIODE		R 141	1	6512A468	RESISTOR	16K-5.14	U 119	1	518037K99	INTEGRATED CIRCUIT	MC044P SCREENED
CR105	1	4834430J02	DIODE		R 142	1	65188A18	RESISTOR	51.5-1.8	U 120	1	518036A74	INTEGRATED CIRCUIT	SN74LS19N SCREENED
CR106	1	4834430J02	DIODE		R 143	1	6512A465	RESISTOR	16K-5.14	U 121	1	518036A74	INTEGRATED CIRCUIT	SN74LS19N SCREENED
L 101	1	248030A46	COIL		R 144	1	6512A441	RESISTOR	47K-5.14	U 122	1	518036A74	INTEGRATED CIRCUIT	SN74LS19N SCREENED
L 102	1	248030A46	COIL		R 145	1	6512A441	RESISTOR	47K-5.14	U 123	1	518036A58	INTEGRATED CIRCUIT	MC14048E SCREENED
L 103	1	248037A28	INDUCTOR	12MH	R 146	1	6512A441	RESISTOR	12K-5.14	U 124	1	518036A74	INTEGRATED CIRCUIT	SN74LS19N SCREENED
Q 101	1	483430A92	TRANSISTOR		R 147	1	6512A407	RESISTOR	18K-5.14	U 125	1	518036A74	INTEGRATED CIRCUIT	SN74LS19N SCREENED
Q 102	1	483036A91	TRANSISTOR	MPS6520 SCREENED	R 148	1	6512A453	RESISTOR	15K-5.14	U 126	1	518036A74	INTEGRATED CIRCUIT	SN74LS19N SCREENED
Q 103	1	483036A92	TRANSISTOR	MPS6519 SCREENED	R 149	1	6512A456	RESISTOR	47K-5.14	U 127	1	518036A74	INTEGRATED CIRCUIT	SN74LS19N SCREENED
Q 104	1	483036A91	TRANSISTOR	MPS6520 SCREENED	R 150	1	6512A441	RESISTOR	47K-5.14	U 128	1	518037M08	INTEGRATED CIRCUIT	MC14086PCP SCREENED
Q 105	1	483036A92	TRANSISTOR	MPS6519 SCREENED	R 151	1	6512A441	RESISTOR	47K-5.14	U 129	1	5180309002	INTEGRATED CIRCUIT	SN74LS73NS SCREENED
Q 106	1	483881C32	TRANSISTOR	MPS6520 SCREENED	R 152	1	6512A427	RESISTOR	2.2K-5.14	U 130	1	518036A18	INTEGRATED CIRCUIT	SN74LS24NS SCREENED
Q 107	1	483036A91	TRANSISTOR	MPS6520 SCREENED	R 153	1	6512A425	RESISTOR	82.5-1.4	U 131	1	5180309002	INTEGRATED CIRCUIT	SN74LS73NS SCREENED
Q 108	1	483036C01	TRANSISTOR	MPS6520 SCREENED	R 154	1	6512A477	RESISTOR	19K-5.14	U 132	1	5180309008	INTEGRATED CIRCUIT	SN74LS24NS SCREENED
R 101	1	6512A473	RESISTOR	16K-5.14	R 155	1	6512A477	RESISTOR	19K-5.14	U 133	1	5180309008	INTEGRATED CIRCUIT	SN74LS24NS SCREENED
R 102	1	6512A468	RESISTOR	16K-5.14	R 156	1	6512A468	RESISTOR	8.2K-5.14	U 134	1	518036A58	INTEGRATED CIRCUIT	MC14086PCP SCREENED
R 103	1	6512A473	RESISTOR	16K-5.14	R 157	1	6512A468	RESISTOR	16K-5.14	U 135	1	518036A11	INTEGRATED CIRCUIT	MC14048E SCREENED
R 104	1	6512A473	RESISTOR	16K-5.14	R 158	1	6512A468	RESISTOR	16K-5.14	U 136	1	518036A58	INTEGRATED CIRCUIT	MC14048E SCREENED
R 105	1	6512A473	RESISTOR	16K-5.14	R 159	1	6512A468	RESISTOR	16K-5.14	U 137	1	518036A58	INTEGRATED CIRCUIT	MC14048E SCREENED
R 106	1	6512A473	RESISTOR	16K-5.14	R 160	1	6512A473	RESISTOR	16K-5.14	U 138	1	518036A58	INTEGRATED CIRCUIT	MC14048E SCREENED
R 107	1	6512A416	RESISTOR	500K-5.14	R 161	1	6512A468	RESISTOR	16K-5.14	U 139	1	518036A58	INTEGRATED CIRCUIT	MC14048E SCREENED
R 108	1	6512A468	RESISTOR	16K-5.14	R 162	1	6512A441	RESISTOR	47K-5.14	U 140	1	518036A58	INTEGRATED CIRCUIT	MC14048E SCREENED
R 109	1	6512A425	RESISTOR	15K-5.14	R 163	1	6512A473	RESISTOR	16K-5.14	U 141	1	518036A58	INTEGRATED CIRCUIT	MC14048E SCREENED
R 110	1	6512A406	RESISTOR	51K-5.14	R 164	1	6512A466	RESISTOR	10K-5.14	U 142	1	518036A58	INTEGRATED CIRCUIT	MC14048E SCREENED
R 111	1	6512A426	RESISTOR	2.0K-5.14	R 165	1	6512A441	RESISTOR	47K-5.14	U 143	1	518036A58	INTEGRATED CIRCUIT	MC14048E SCREENED
R 112	1	6512A456	RESISTOR	2.0K-5.14	R 166	1	6512A466	RESISTOR	2.0K-5.14	U 144	1	518036A58	INTEGRATED CIRCUIT	MC14048E SCREENED
R 113	1	6512A456	RESISTOR	2.0K-5.14	R 167	1	6512A441	RESISTOR	47K-5.14	U 145	1	518036A58	INTEGRATED CIRCUIT	MC14048E SCREENED
R 114	1	6512A456	RESISTOR	2.0K-5.14	R 168	1	6512A441	RESISTOR	47K-5.14	U 146	1	518036A58	INTEGRATED CIRCUIT	MC14048E SCREENED
R 115	1	6512A456	RESISTOR	2.0K-5.14	R 169	1	6512A473	RESISTOR	33K-5.14	VR101	1	518036A25	INTEGRATED CIRCUIT	MC14010PCP SCREENED
R 116	1	6512A441	RESISTOR	47K-5.14	R 170	1	6512A447	RESISTOR	82K-5.14	VR102	1	48313A458	DIODE ZENER	5.6V-4
R 117	1	6512A456	RESISTOR	2.0K-5.14	R 171	1	6512A443	RESISTOR	56K-5.12	VR103	1	48313A458	DIODE ZENER	5.6V-4
R 118	1	6512A441	RESISTOR	47K-5.14	R 172	1	6512A443	RESISTOR	3.3K-5.14	VR104	1	483229C50	DIODE ZENER	3.6V-4
R 119	1	6512A441	RESISTOR	47K-5.14	R 173	1	6512A473	RESISTOR	16K-5.14					
R 120	1	6512A441	RESISTOR	47K-5.14	R 174	1	6512A427	RESISTOR	12K-5.14					

Figure 11-5. Digital Synthesizer AS41 (RTC-4009B)
Parts Location Diagram
(Sheet 2 of 2)

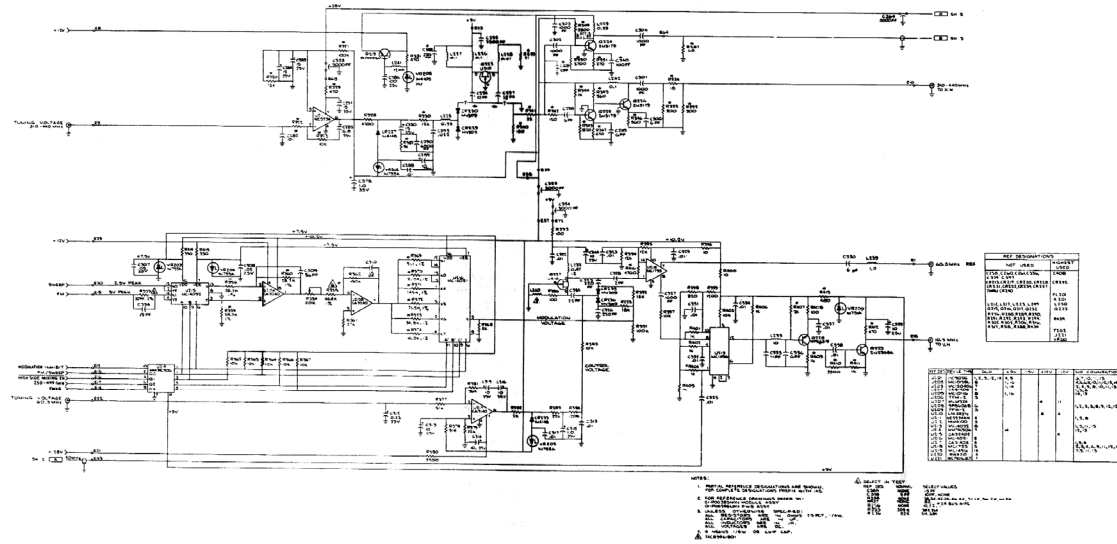

Figure 11-6. RF Synthesizer AS2A
Schematic Diagram (Sheet 1 of 3)

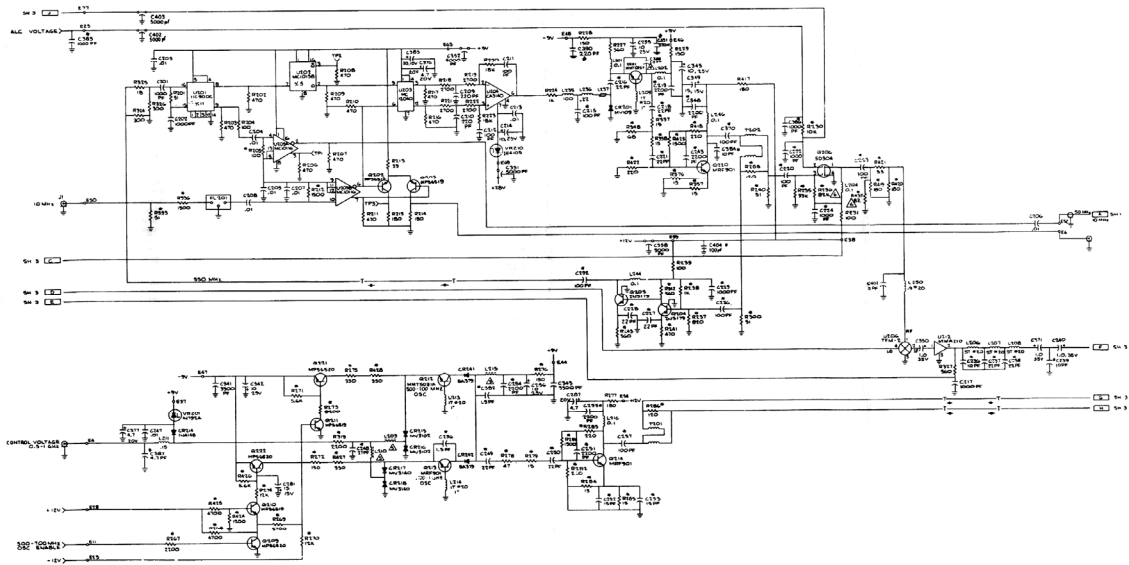

Figure 11-6. RF Synthesizer ASA2
Schematic Diagram (Sheet 2 of 3)

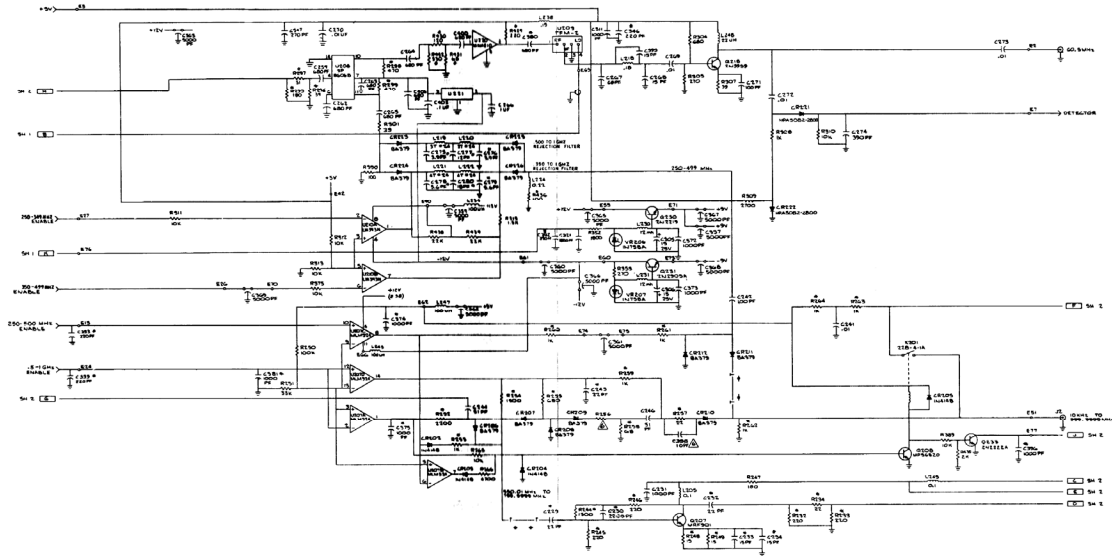

Figure 11-6. RF Synthesizer ASA2
Schematic Diagram (Sheet 3 of 3)

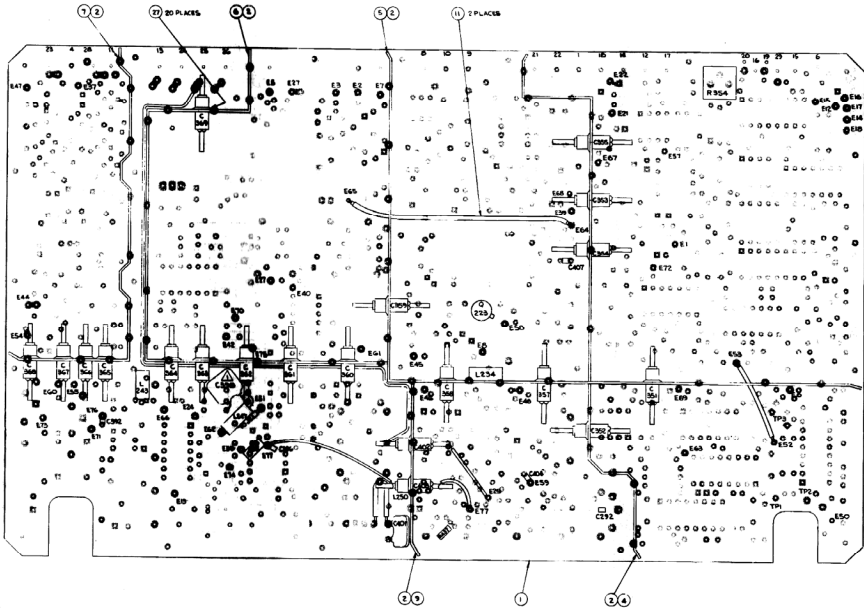

Figure 11-7. RF Synthesizer A5A2 (RTC-4010B) Parts Location Diagram

Find No.	Qty. Req.	Part No.	Nomenclature	Part Value	Find No.	Qty. Req.	Part No.	Nomenclature	Part Value	Find No.	Qty. Req.	Part No.	Nomenclature	Part Value
C 370	1	21-80370A21	CAPACITOR	100PF-20-100	F2201	1	48-80384A28	CRYSTAL FILTER	10MAZ-2 POLE	Q 223	1	48-80384A21	TRANSISTOR	
C 371	1	2302841815	CAPACITOR	1.0UF-20-35	4 201	1	48-80384A32	RES. 4W		Q 217	1	48-80384A41	TRANSISTOR	
C 372	1	21-80396A51	CAPACITOR	1000PF-10-100	1 201	1	24-80396A19	COLL.	1UH	Q 217	1	48-8089503	TRANSISTOR	
C 373	1	21-80396A51	CAPACITOR	1000PF-10-100	1 202	1	24-80396A19	COLL.	1UH	Q 218	1	48-80384A50	TRANSISTOR	
C 374	1	21-80370A22	CAPACITOR	1000PF-20-100	1 203	1	24-80389A60	COLL. AIR WOUND	17 #20	Q 223	1	48-80384A52	TRANSISTOR	MPS6819 SCREENED
C 375	1	21-80370A22	CAPACITOR	1000PF-20-100	1 204	1	24-80389A19	COLL.	1UH	Q 230	1	48-80861C52	TRANSISTOR	
C 376	1	2302841815	CAPACITOR	4.7UF-20-20	1 205	1	24-80389A19	COLL.	1UH	Q 221	1	48-808145	TRANSISTOR	
C 377	1	2302841815	CAPACITOR	4.7UF-20-20	1 206	1	24-80389A19	COLL. AIR WOUND	5 #20	Q 222	1	48-2089C21	TRANSISTOR	
C 378	1	2302841815	CAPACITOR	1.0UF-20-35	1 207	1	24-80389A49	COLL. AIR WOUND	5 #20	Q 201	1	65124A18	RESISTOR	51.5-1.4
C 380	1	21-80370A29	CAPACITOR	500PF-20-100	1 208	1	24-80389A49	COLL. AIR WOUND	5 #20	Q 202	1	65124A41	RESISTOR	470.5-1.4
C 381	1	21-80370A22	CAPACITOR	1000PF-20-100	1 209	1	24C80961801	CHOKER RF		Q 203	1	65124A41	RESISTOR	470.5-1.4
C 382	1	21-80370A29	CAPACITOR	1000PF-20-100	1 210	1	24C80961801	CHOKER RF		Q 204	1	65124A25	RESISTOR	470.5-1.4
C 383	1	2302841815	CAPACITOR	100PF-5-100	1 211	1	24-80389A23	COLL.	15UH	Q 205	1	65124A25	RESISTOR	100.5-1.8
C 384	1	21-80370A10	CAPACITOR	1000PF-20-100	1 212	1	24-80389A60	COLL. AIR WOUND	17 #20	Q 206	1	65124A41	RESISTOR	470.5-1.4
C 385	1	21-80370A22	CAPACITOR	1000PF-20-100	1 213	1	24-80389A60	COLL. AIR WOUND	17 #20	Q 207	1	65124A41	RESISTOR	470.5-1.4
C 386	1	21-80370A19	CAPACITOR	4.7VF-10-100	1 214	1	24-80389A19	COLL.	1UH	Q 208	1	65124A41	RESISTOR	470.5-1.4
C 387	1	21-80370A19	CAPACITOR	1.5VF-5PF-100	1 215	1	24-80389A19	COLL.	1UH	Q 209	1	65124A41	RESISTOR	470.5-1.4
C 388	101	21-80370A29	CAPACITOR	220PF-20-100	1 216	1	24-80389A24	COLL.	15UH	Q 210	1	65124A41	RESISTOR	470.5-1.4
C 389	1	21-80370A29	CAPACITOR	220PF-20-100	1 217	1	24-80389A48	COLL. AIR WOUND	37 #24	Q 211	1	65124A41	RESISTOR	470.5-1.4
C 390	1	21-80370A29	CAPACITOR	220PF-20-100	1 218	1	24-80389A48	COLL. AIR WOUND	27 #24	Q 212	1	65124A41	RESISTOR	1.8M-5-1.8
C 391	1	21-80370A29	CAPACITOR	220PF-20-100	1 219	1	24-80389A41	COLL. AIR WOUND	47 #24	Q 213	1	65124A31	RESISTOR	180.5-1.4
C 392	1	21-80370A29	CAPACITOR	220PF-20-100	1 220	1	24-80389A41	COLL. AIR WOUND	47 #24	Q 214	1	65124A31	RESISTOR	180.5-1.4
C 393	1	21-80370A29	CAPACITOR	220PF-20-100	1 221	1	24-80389A26	COLL.	30UH	Q 215	1	65124A15	RESISTOR	30.5-1.4
C 394	1	2108449838	CAPACITOR	15PF-5-500	1 222	1	24-80389A26	COLL.	30UH	Q 216	1	65124A41	RESISTOR	470.5-1.4
C 395	1	2108449838	CAPACITOR	15PF-5-500	1 223	1	24-80389A19	COLL.	1UH	Q 217	1	65124A41	RESISTOR	470.5-1.4
C 396	1	21-80370A22	CAPACITOR	1000PF-20-100	1 224	1	24-80389A19	COLL.	1UH	Q 218	1	65124A50	RESISTOR	2.7K-5-1.4
C 398	VAR	21-80396A1	CAPACITOR	10PF-5-500	1 225	1	24-80389A27	COLL.	47UH	Q 219	1	65124A50	RESISTOR	2.7K-5-1.4
C 399	1	21-80370A29	CAPACITOR	220PF-20-100	1 226	1	24-80389A26	COLL.	30UH	Q 220	1	65124A79	RESISTOR	18K-5-1.4
C 400	1	21-80370A29	CAPACITOR	220PF-20-100	1 227	1	24-80389A26	COLL.	30UH	Q 221	1	65124A50	RESISTOR	2.7K-5-1.4
C 401	1	21-80370A29	CAPACITOR	220PF-20-100	1 228	1	24-80370A39	INDUCTOR	12MH	Q 222	1	65124A50	RESISTOR	2.7K-5-1.4
C 402	1	2404-603-15V05022	CAPACITOR	5000PF-20-80-500	1 229	1	24-80389A14	COLL.	47UH	Q 223	1	65124A79	RESISTOR	18K-5-1.4
C 403	1	2404-603-15V05022	CAPACITOR	5000PF-20-80-500	1 230	1	24-80389A29	COLL.	10UH	Q 224	1	65124A49	RESISTOR	18K-5-1.4
C 404	1	21-80370A21	CAPACITOR	1000PF-20-100	1 231	1	24-80389A27	COLL.	100UH	Q 225	1	65124A79	RESISTOR	18K-5-1.4
C 405	1	21-80389A2	CAPACITOR	1UF-20-100	1 232	1	24-80389A37	COLL.	100UH	Q 226	1	65124A43	RESISTOR	560.5-1.8
C 406	1	21-80370A29	CAPACITOR	800PF-20-50	1 233	1	24-80389A26	COLL.	100UH	Q 227	1	65124A29	RESISTOR	100.5-1.4
C 407	1	21-80370A29	CAPACITOR	1.5PF-5PF-100	1 234	1	59-8300001	FERMITE BEAD		Q 228	1	65124A29	RESISTOR	100.5-1.4
C 408	1	21-80370A10	CAPACITOR	10PF-5-100	1 235	1	24-80389A23	COLL.	15UH	Q 230	1	65185A73	RESISTOR	10K-5-1.8
CR201	1	48-80396A6	DIODE VARACTOR		1 236	1	24-80389A22	COLL.	1UH	Q 231	1	65124A25	RESISTOR	220.5-1.8
CR202	1	48-8448302	DIODE		1 237	1	24C80961801	CHOKER RF		Q 232	1	65185A33	RESISTOR	10K-5-1.8
CR203	1	48-8448302	DIODE		1 238	1	24-80370A39	INDUCTOR	12MH	Q 233	1	65185A33	RESISTOR	220.5-1.8
CR204	1	48-8448302	DIODE		1 239	1	24-80389A19	COLL.	1UH	Q 234	1	65185A30	RESISTOR	220.5-1.8
CR205	1	48-8448302	DIODE		1 240	1	24-80389A27	COLL.	100UH	Q 235	1	65185A85	RESISTOR	32K-5-1.8
CR206	1	48-80345A2	DIODE		1 241	1	24-80389A19	COLL.	1UH	Q 236	1	65185A95	RESISTOR	82K-5-1.8
CR207	1	48-80345A2	DIODE		1 242	1	24-80389A19	COLL.	1UH	Q 237	1	65185A95	RESISTOR	51K-5-1.8
CR208	1	48-80345A2	DIODE		1 243	1	24-80389A19	COLL.	1UH	Q 238	1	65185A90	RESISTOR	68K-5-1.8
CR209	1	48-80345A2	DIODE		1 244	1	24-80389A37	COLL.	100UH	Q 239	1	65185A47	RESISTOR	820.5-1.8
CR210	1	48-80345A2	DIODE		1 245	1	24-80389A21	COLL.	100UH	Q 240	1	65185A47	RESISTOR	18K-5-1.8
CR211	1	48-80345A2	DIODE		1 246	1	24-80389A52	COLL. AIR WOUND	20UH	Q 241	1	65124A25	RESISTOR	100.5-1.4
CR212	1	48-80345A2	DIODE		1 247	1	48-80384A45	TRANSISTOR		Q 242	1	65185A18	RESISTOR	51.5-1.8
CR214	1	48-8448302	DIODE		1 248	1	48-80389A02	TRANSISTOR	MPS6819 SCREENED	Q 243	1	65185A41	RESISTOR	470.5-1.8
CR215	1	48-80396A47	VARACTOR		1 249	1	48-80389A02	TRANSISTOR	MPS6819 SCREENED	Q 244	1	65185A43	RESISTOR	560.5-1.8
CR216	1	48-80396A47	VARACTOR		1 250	1	48-80389A02	TRANSISTOR		Q 245	1	65185A43	RESISTOR	560.5-1.8
CR217	1	48-80396A47	VARACTOR		1 251	1	48-80389A02	TRANSISTOR		Q 246	1	65185A43	RESISTOR	1.5K-5-1.8
CR218	1	48-80396A47	VARACTOR		1 252	1	48-80389A02	TRANSISTOR		Q 247	1	65185A43	RESISTOR	220.5-1.8
CR221	1	48-80345A2	DIODE		1 253	1	48-80389A02	TRANSISTOR		Q 248	1	65124A31	RESISTOR	180.5-1.4
CR222	1	48-80345A2	DIODE		1 254	1	48-80389A02	TRANSISTOR		Q 249	1	65185A05	RESISTOR	15.5-1.8
CR223	1	48-80345A2	DIODE		1 255	1	48-80389A02	TRANSISTOR		Q 250	1	65185A05	RESISTOR	15.5-1.8
CR224	1	48-80345A2	DIODE		1 256	1	48-80389A02	TRANSISTOR		Q 251	1	65124A85	RESISTOR	33K-5-1.4
CR225	1	48-80345A2	DIODE		1 257	1	48-80389A02	TRANSISTOR		Q 252	1	65185A17	RESISTOR	2.2K-5-1.8
CR227	1	48-8448302	DIODE		1 258	1	48-80389A02	TRANSISTOR		Q 253	1	65185A18	RESISTOR	1K-5-1.8
CR229	1	48-80389A96	DIODE VARACTOR	MV309 SCREENED	1 259	1	48-80389A02	TRANSISTOR						
CR230	1	48-80389A96	DIODE VARACTOR	MV309 SCREENED	1 260	1	48-80389A02	TRANSISTOR						
CR233	1	48-8448302	DIODE		1 261	1	48-80389A02	TRANSISTOR						
CR235	1	48-80389A96	DIODE VARACTOR	MV309 SCREENED	1 262	1	48-80389A02	TRANSISTOR						
CR236	1	48-80389A96	DIODE VARACTOR	MV309 SCREENED	1 263	1	48-80389A02	TRANSISTOR						
CR241	1	48-80345A2	DIODE		1 264	1	48-80389A02	TRANSISTOR	MPS6820 SCREENED					
CR242	1	48-80345A2	DIODE		1 265	1	48-80389A02	TRANSISTOR	MPS6820 SCREENED					

Figure 11-7. RF Synthesizer A5A2 (RTC-4010B) Parts Location Diagram

SECTION 12

AUDIO SYNTHESIZER (A6)

12-1. General. Generation, processing, and control of modulation audio is the function of the Audio Synthesizer module. Three modulation signals, private line, digital private line, and a fixed 1 kHz, are generated on the board. Processing for external microphone and BNC jack audio inputs as well as summation of all modulation sources to form a composite source is provided. Switching of the composite source to the appropriate modulator completes the function of the Audio Synthesizer. A block diagram of the Audio Synthesizer is shown in figure 12-1 with its schematic in figure 12-2.

12-2. Private Line Generator. Private line tones from 10 Hz to 10 kHz in 0.1 Hz increments are synthesized using a phase accumulative technique. Consider the 360 degrees in a cycle to be divided into 2^{20} pieces. A 20 bit digital accumulator incrementing at some fixed rate could then at any instant represent a fixed point in the 360 cycle. That is, if the accumulator was half full it would represent the 180° point and if totally full would represent the 360° point.

12-3. The number of times per second that the accumulator goes through its complete cycle determines the output frequency. If the increment rate is fixed, the time required to accumulate 2^{20} bits can be changed by changing the number of bits added at each increment time.

12-4. The PL synthesizer increments at a 104 857.6 Hz rate so that if only one bit were added each time, the time to complete one cycle would be 10 seconds. Processor loaded control latches determine the number of bits to be added at each increment time and thus the final output frequency. A 20 Bit Adder adds the control word to the current word in the 20 bit accumulator Latch. At the next increment time the Adder output is latched and becomes the next input to the Adder.

12-5. Conversion of the linear digital output of the 20-Bit Latch accumulator into a sinusoidal digital output is the function of the Decode ROM. A Digital to Analog (D/A) converter following the ROM converts the sinusoidal information into a quantized sinewave having a period equal to the cycle time of the 20-Bit Latch accumulator.

12-6. A bandpass filter with a 10 Hz to 10 kHz passband filters the quantized waveform to a sinewave having less than 1% distortion. The level of the sinewave is processor controllable by a programmable attenuator having 0, 10, 20, and 30 dB settings. The output of the PL generator is switched with the output of the DPL generator to give the INT MOD signal.

12-7. DPL Generator. The 23 bit Digital Private Line (DPL) word is generated by the processor from the 3-digit code. The 23-bit word is then transferred to a serial shift register and clocked out at a 133 Hz rate. Connecting the output of the shift register back to its input causes the 23-bit word to be continuously repeated.

12-8. A 133 Hz tone from the PL generator is the DPL clock input. For the DPL output mode the tone is gated to the clock input of the shift register by the Shift Register Control circuit. During the load mode the Shift Register Control gates a control latch to the shift register input. Twenty three data bits and clock pulses are then provided by the processor to load the DPL word. At the completion of the load mode, the Shift Register Control switches back to the output mode to cause the DPL word to be cycled through the shift register at the 133 Hz rate.

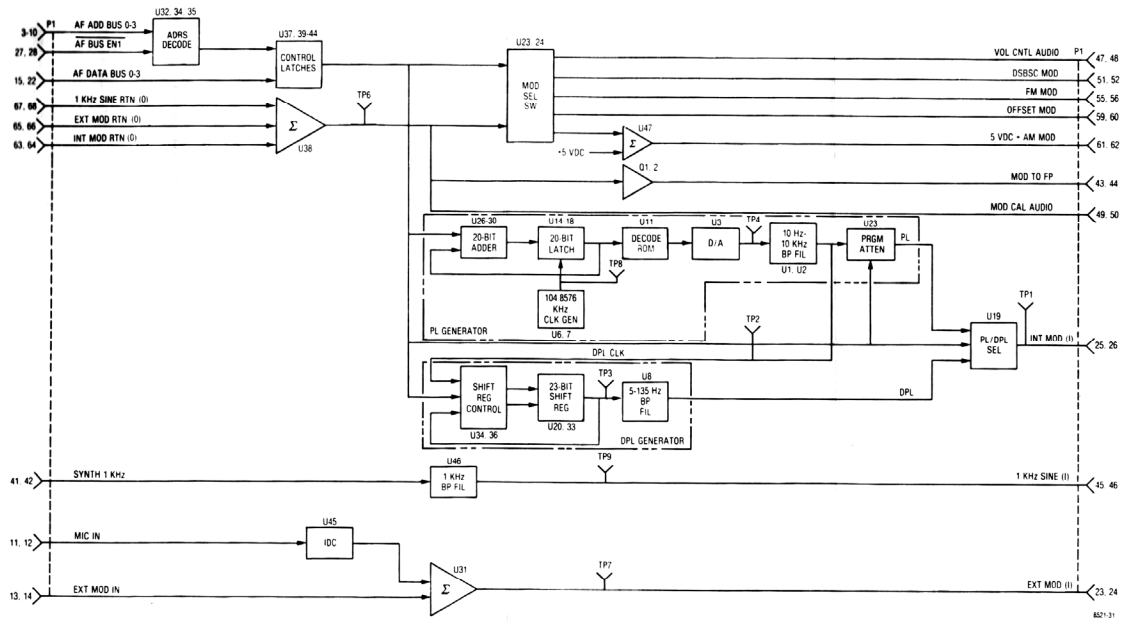

Figure 12-1. Audio Synthesizer A6 Block Diagram

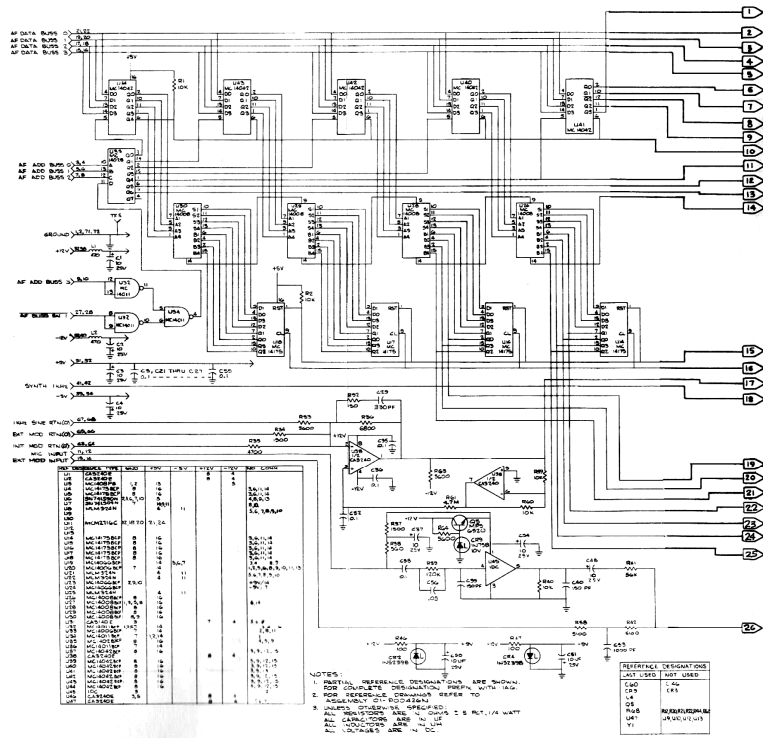

Figure 12-2. Audio Synthesizer A6 Schematic Diagram (Sheet 1 of 2)

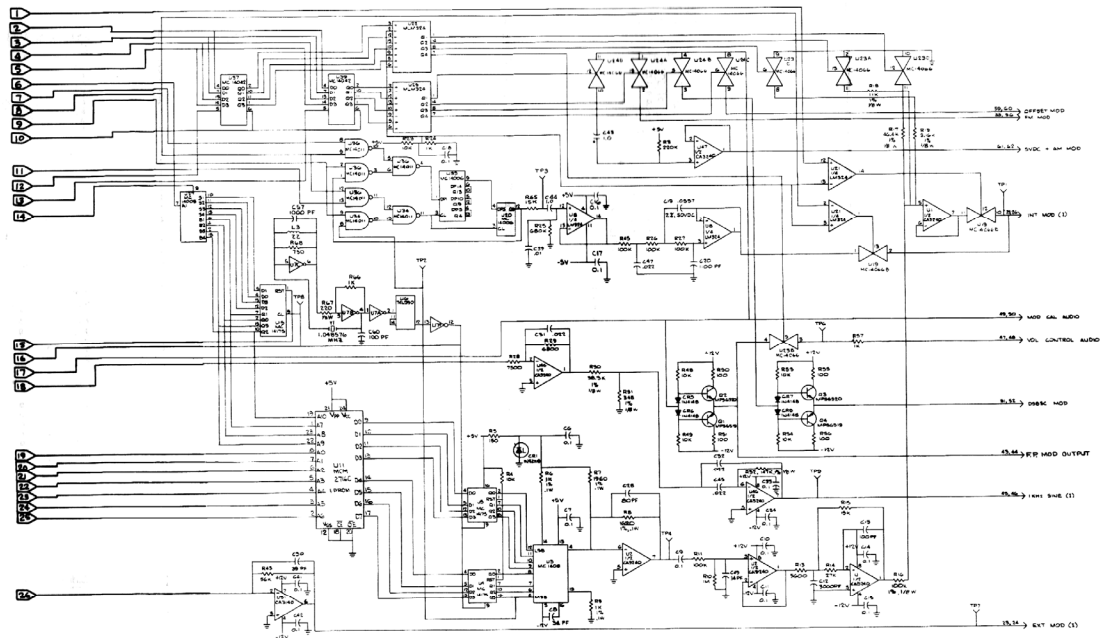

Figure 12-2. Audio Synthesizer A6 Schematic Diagram (Sheet 2 of 2)

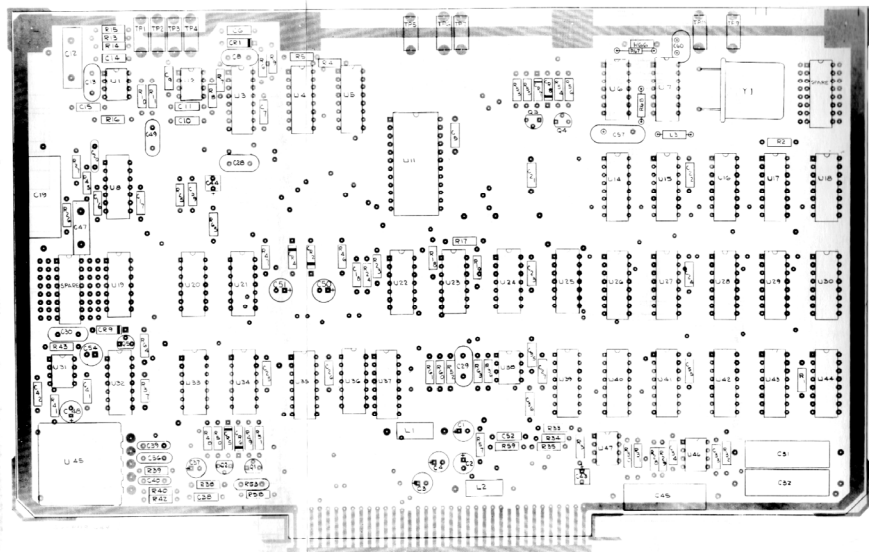

Figure 12-3. Audio Synthesizer A6 (RTC-4011B) Parts Location Diagram (Sheet 1 of 3)

Find No.	Qty. Req.	Part No.	Nomenclature	Part Value	Find No.	Qty. Req.	Part No.	Nomenclature	Part Value
		RTC-4011B	AUDIO SYNTHESIZER						
001	1	84803108V001	PWB AUDIO SYNTHESI		C 045	1	00084326A48	CAPACITOR	022UF-1-50
002	1	07-80353A63	BRACKET,PWB MITG		C 047	1	00082096J08	CAPACITOR	022UF-10-250
003	4	MS20470AD4-5	RIVET	1.8X.312	C 048	1	000820396A40	CAPACITOR	10UF-25V
004	AR	SNE3WRP3	SOLDER		C 049	1	0008204494B30	CAPACITOR	34PF-5-500
005	AR	1114167A01	INK	BLACK	C 050	1	000820396A40	CAPACITOR	10UF-25V
006	2	5C84500B03	EYELET		C 051	1	000820396A40	CAPACITOR	10UF-25V
007	2	42C84284B01	RETAINER		C 052	1	000820396A49	CAPACITOR	1UF-20-100
008	2	03-139581	SCREW,PH	4.40X.312	C 053	1	000820396A51	CAPACITOR	1000PF-10-100
009	AR	RTV3145	ADHESIVE,SIL RUBBE		C 054	1	000820396A40	CAPACITOR	10UF-25V
C 001	1	23-80396A40	CAPACITOR	10UF-25V	C 055	1	000820396A49	CAPACITOR	1UF-20-100
C 002	1	23-80396A40	CAPACITOR	10UF-25V	C 056	1	000820396A49	CAPACITOR	1UF-20-100
C 003	1	23-80396A40	CAPACITOR	10UF-25V	C 057	1	00082096D102J03	CAPACITOR	05UF-5-500
C 004	1	23-80396A40	CAPACITOR	10UF-25V	C 058	1	000820396A19	CAPACITOR	01UF-20-500
C 005	1	21-80396A49	CAPACITOR	1UF-20-100	C 060	1	201650118	CAPACITOR	100PF-5-500
C 006	1	21-80396A49	CAPACITOR	1UF-20-100	CR001	1	48B0345A80	DIODE,ZENER	24V-5.5
C 007	1	21-80396A49	CAPACITOR	1UF-20-100	CR002	1	48B0345A81	DIODE,ZENER	9V
C 008	1	21D84494B30	CAPACITOR	34PF-5-500	CR004	1	48B0345A81	DIODE,ZENER	9V
C 009	1	21-80396A49	CAPACITOR	1UF-20-100	CR005	1	48B4463K02	DIODE	
C 010	1	21-80396A49	CAPACITOR	1UF-20-100	CR006	1	48B4463K02	DIODE	
C 011	1	21-80396A49	CAPACITOR	1UF-20-100	CR007	1	48B4463K02	DIODE	
C 012	1	21H85335	CAPACITOR	3000PF-2-500	CR008	1	48B4463K02	DIODE	
C 013	1	21D84494B04	CAPACITOR	100PF-5-500	CR009	1	48B2256C11	DIODE,ZENER	10V-5.4
C 014	1	21-80396A49	CAPACITOR	1UF-20-100	L 001	1	2414119A55	COIL	470UH
C 015	1	21-80396A49	CAPACITOR	1UF-20-100	L 002	1	2414119A55	COIL	470UH
C 016	1	21-80396A49	CAPACITOR	1UF-20-100	L 003	1	2414119A55	COIL	22UH
C 017	1	21-80396A49	CAPACITOR	1UF-20-100	O 001	1	48B0368A92	TRANSISTOR	MPS6519 SCREENED
C 018	1	21-80396A49	CAPACITOR	1UF-20-100	O 002	1	48B0368A91	TRANSISTOR	MPS6520 SCREENED
C 019	1	06B84326A27	CAPACITOR	0557UF-2-50	O 003	1	48B0368A91	TRANSISTOR	MPS6520 SCREENED
C 020	1	21D83596E32	CAPACITOR	1100PF-5-200	O 004	1	48B0368A92	TRANSISTOR	MPS6519 SCREENED
C 021	1	21-80396A49	CAPACITOR	1UF-20-100	O 005	1	48B0368A91	TRANSISTOR	MPS6520 SCREENED
C 022	1	21-80396A49	CAPACITOR	1UF-20-100	R 001	1	65124A73	RESISTOR	10K-5-1/4
C 023	1	21-80396A49	CAPACITOR	1UF-20-100	R 002	1	65124A73	RESISTOR	10K-5-1/4
C 024	1	21-80396A49	CAPACITOR	1UF-20-100	R 003	1	65124A73	RESISTOR	220K-5-1/4
C 025	1	21-80396A49	CAPACITOR	1UF-20-100	R 004	1	65124A73	RESISTOR	150-5-1/4
C 026	1	21-80396A49	CAPACITOR	1UF-20-100	R 005	1	65124A29	RESISTOR	1000-1-1/8
C 027	1	21-80396A49	CAPACITOR	1UF-20-100	R 006	1	0610621B94	RESISTOR	1560-1-1/8
C 028	1	21D84494B03	CAPACITOR	80PF-5-500	R 007	1	0610621C23	RESISTOR	1620-1-1/8
C 029	1	21D84494B16	CAPACITOR	330PF-5-500	R 008	1	0610621C15	RESISTOR	1000-1-1/8
C 030	1	21D84494B24	CAPACITOR	39PF-5-500	R 009	1	0610621B94	RESISTOR	1620-1-1/8
C 031	1	06B84326A48	CAPACITOR	022UF-1-50	R 010	1	65124B22	RESISTOR	1M-5-1/4
C 032	1	06B84326A48	CAPACITOR	022UF-1-50	R 011	1	65124A97	RESISTOR	100K-5-1/4
C 033	1	21-80396A49	CAPACITOR	1UF-20-100	R 013	1	65124A67	RESISTOR	5.6K-5-1/4
C 034	1	21-80396A49	CAPACITOR	1UF-20-100	R 014	1	65124A83	RESISTOR	27K-5-1/4
C 035	1	21-80396A49	CAPACITOR	1UF-20-100	R 015	1	65124A77	RESISTOR	15K-5-1/4
C 036	1	21-80396A49	CAPACITOR	1UF-20-100	R 016	1	0610621D88	RESISTOR	48.4K-1-1/8
C 037	1	23-80396A40	CAPACITOR	10UF-25V	R 017	1	0610621D56	RESISTOR	11K-1-1/8
C 038	1	21-80396A49	CAPACITOR	1UF-20-100	R 018	1	0610621C95	RESISTOR	3160-1-1/8
C 039	1	21D84494B07	CAPACITOR	150PF-5-500	R 019	1	0610621C43	RESISTOR	1K-5-1/4
C 040	1	21D84494B07	CAPACITOR	150PF-5-500	R 023	1	65B24A73	RESISTOR	680K-5-1/4
C 041	1	21-80396A49	CAPACITOR	1UF-20-100	R 024	1	65B24A49	RESISTOR	100K-5-1/4
C 042	1	21-80396A49	CAPACITOR	1UF-20-100	R 025	1	65B24B18	RESISTOR	680K-5-1/4
C 043	1	23D83441B15	CAPACITOR	1.0UF-20-35	R 026	1	65B24A97	RESISTOR	100K-5-1/4
C 044	1	23D83441B15	CAPACITOR	1.0UF-20-35	R 027	1	65B24A97	RESISTOR	100K-5-1/4

Figure 12-3. Audio Synthesizer A6 (RTC-4011B)
Parts Location Diagram
(Sheet 2 of 3)

Find No.	Qty. Req.	Part No.	Nomenclature	Part Value	Find No.	Qty. Req.	Part No.	Nomenclature	Part Value
R 028	1	65124A72	RESISTOR	7.5K-5-1/4	U 006	1	51-80086A26	INTEGRATED CIRCUIT	SN74LS04NS SCREENED
R 029	1	65124A80	RESISTOR	4.8K-5-1/4	U 007	1	51-80086A11	INTEGRATED CIRCUIT	SN74LS04NS SCREENED
R 030	1	06-10821Q48	RESISTOR	38.3K-1-1/8	U 008	1	51-80086A16	INTEGRATED CIRCUIT	LM224N SCREENED
R 031	1	06-10821R80	RESISTOR	34K-1-1/8	U 011	1	51-80094A03	INTEGRATED CIRCUIT	2K X 8 EPROM
R 032	1	06-10821R08	RESISTOR	145K-1-1/8	U 014	1	51-80086A46	INTEGRATED CIRCUIT	MC141780CP SCREENED
R 033	1	65124A82	RESISTOR	3.9K-5-1/4	U 015	1	51-80086A46	INTEGRATED CIRCUIT	MC141780CP SCREENED
R 034	1	65124A83	RESISTOR	1.5K-5-1/4	U 016	1	51-80086A46	INTEGRATED CIRCUIT	MC141780CP SCREENED
R 035	1	65124A83	RESISTOR	4.2K-5-1/4	U 017	1	51-80086A46	INTEGRATED CIRCUIT	MC141780CP SCREENED
R 036	1	65124A88	RESISTOR	6.8K-5-1/4	U 018	1	51-80086A46	INTEGRATED CIRCUIT	MC141780CP SCREENED
R 037	1	65124A83	RESISTOR	100K-5-1/4	U 019	1	51-80086A46	INTEGRATED CIRCUIT	MC141780CP SCREENED
R 038	1	65124A42	RESISTOR	980-5-1/4	U 020	1	51-80086A30	INTEGRATED CIRCUIT	MC140860CP SCREENED
R 039	1	65124A89	RESISTOR	100K-5-1/4	U 021	1	51-80086A16	INTEGRATED CIRCUIT	LM224N SCREENED
R 040	1	65124A72	RESISTOR	10K-5-1/4	U 022	1	51-80086A16	INTEGRATED CIRCUIT	LM224N SCREENED
R 041	1	65124A81	RESISTOR	50K-5-1/4	U 023	1	51-8086A48	INTEGRATED CIRCUIT	MC140860CP SCREENED
R 042	1	65124A88	RESISTOR	51K-5-1/4	U 024	1	51-8086A48	INTEGRATED CIRCUIT	MC140860CP SCREENED
R 043	1	65124A81	RESISTOR	56K-5-1/4	U 025	1	51-80086A16	INTEGRATED CIRCUIT	LM224N SCREENED
R 044	1	65124A87	RESISTOR	100K-5-1/4	U 026	1	51-80086A31	INTEGRATED CIRCUIT	MC140860CP SCREENED
R 045	1	65124A87	RESISTOR	100K-5-1/4	U 027	1	51-80086A31	INTEGRATED CIRCUIT	MC140860CP SCREENED
R 046	1	65124A29	RESISTOR	100K-5-1/4	U 028	1	51-80086A31	INTEGRATED CIRCUIT	MC140860CP SCREENED
R 047	1	65124A29	RESISTOR	100K-5-1/4	U 029	1	51-80086A31	INTEGRATED CIRCUIT	MC140860CP SCREENED
R 048	1	65124A72	RESISTOR	10K-5-1/4	U 030	1	51-80086A31	INTEGRATED CIRCUIT	MC140860CP SCREENED
R 049	1	65124A72	RESISTOR	10K-5-1/4	U 041	1	51-80086A31	INTEGRATED CIRCUIT	MC140860CP SCREENED
R 050	1	65124A29	RESISTOR	100K-5-1/4	U 042	1	51-80086A31	INTEGRATED CIRCUIT	MC140860CP SCREENED
R 051	1	65124A29	RESISTOR	100K-5-1/4	U 043	1	51-80086A31	INTEGRATED CIRCUIT	MC140860CP SCREENED
R 052	1	65124A29	RESISTOR	100K-5-1/4	U 044	1	51-80086A31	INTEGRATED CIRCUIT	MC140860CP SCREENED
R 053	1	65124A72	RESISTOR	10K-5-1/4	U 045	1	61-9998A32	INTEGRATED CIRCUIT	MC141180CP SCREENED
R 054	1	65124A72	RESISTOR	10K-5-1/4	U 046	1	61-9998A32	INTEGRATED CIRCUIT	MC141180CP SCREENED
R 055	1	65124A82	RESISTOR	100K-5-1/4	U 047	1	51-80086A32	INTEGRATED CIRCUIT	MC140860CP SCREENED
R 056	1	65124A25	RESISTOR	100K-5-1/4	U 048	1	51-80086A32	INTEGRATED CIRCUIT	MC140860CP SCREENED
R 057	1	65124A40	RESISTOR	1K-5-1/4	U 049	1	51-80086A32	INTEGRATED CIRCUIT	MC140860CP SCREENED
R 058	1	65124A86	RESISTOR	51K-5-1/4	U 050	1	51-80086A32	INTEGRATED CIRCUIT	MC140860CP SCREENED
R 059	1	65124A72	RESISTOR	10K-5-1/4	U 040	1	51-80086A38	INTEGRATED CIRCUIT	MC140860CP SCREENED
R 060	1	65124A86	RESISTOR	100K-5-1/4	U 041	1	51-80086A38	INTEGRATED CIRCUIT	MC140860CP SCREENED
R 061	1	65124B30	RESISTOR	4.7M-5-1/4	U 042	1	51-80086A38	INTEGRATED CIRCUIT	MC140860CP SCREENED
R 062	1	65124A87	RESISTOR	5.6K-5-1/4	U 043	1	51-80086A38	INTEGRATED CIRCUIT	MC140860CP SCREENED
R 063	1	65124A87	RESISTOR	5.6K-5-1/4	U 044	1	51-80086A38	INTEGRATED CIRCUIT	MC140860CP SCREENED
R 064	1	65124A77	RESISTOR	19K-5-1/4	U 045	1	18071486A	INTEGRATED CIRCUIT	MC140860CP SCREENED
R 065	1	65124A49	RESISTOR	100K-5-1/4	U 046	1	51-80086A40	INTEGRATED CIRCUIT	MC140860CP SCREENED
R 067	1	65124A32	RESISTOR	22K-5-1/4	U 047	1	51-80086A40	INTEGRATED CIRCUIT	MC140860CP SCREENED
R 068	1	65124A46	RESISTOR	750-5-1/4	U 048	1	48-8054A07	CRYSTAL	1.94878MHz±20ppm
T9001	1	09-80231A88	JACK,TIP	WHT					
T9002	1	09-80231A88	JACK,TIP	WHT					
T9003	1	09-80231A88	JACK,TIP	WHT					
T9004	1	09-80231A88	JACK,TIP	WHT					
T9005	1	09-80231A88	JACK,TIP	WHT					
T9006	1	09-80231A88	JACK,TIP	WHT					
T9007	1	09-80231A88	JACK,TIP	WHT					
T9008	1	09-80231A88	JACK,TIP	WHT					
T9009	1	09-80231A88	JACK,TIP	WHT					
U 001	1	51-80086A34	INTEGRATED CIRCUIT						
U 002	1	51-80345A04	INTEGRATED CIRCUIT						
U 003	1	51-8097909A	INTEGRATED CIRCUIT						
U 004	1	51-80086A48	INTEGRATED CIRCUIT						
U 005	1	51-80086A48	INTEGRATED CIRCUIT						

Figure 12-3. Audio Synthesizer A6 (RTC-4011B)
Parts Location Diagram
(Sheet 3 of 3)

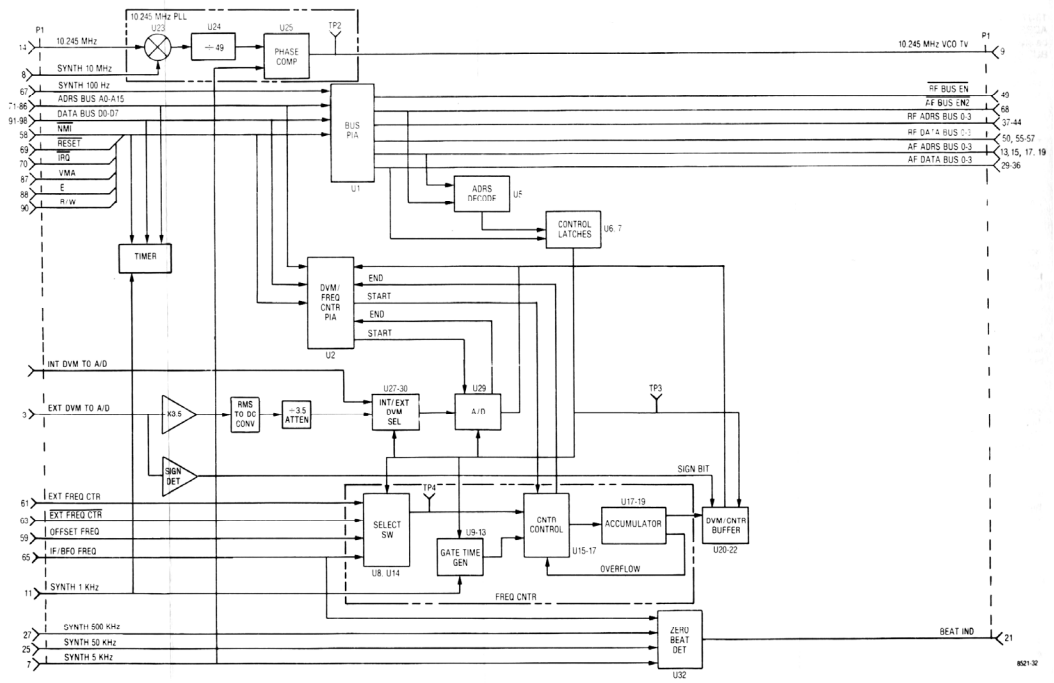

Figure 13-1. Processor I/O A7 Block Diagram

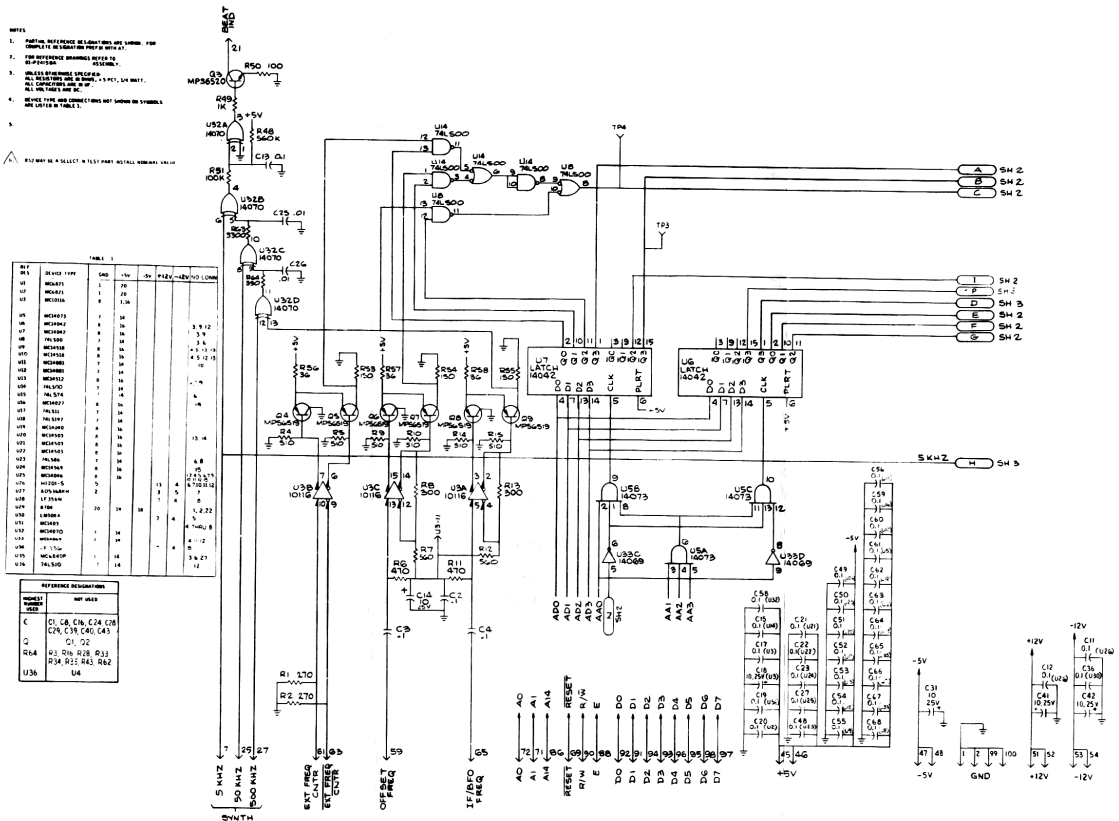

Figure 13-2. Processor I/O A7 Schematic Diagram (Sheet 1 of 3)

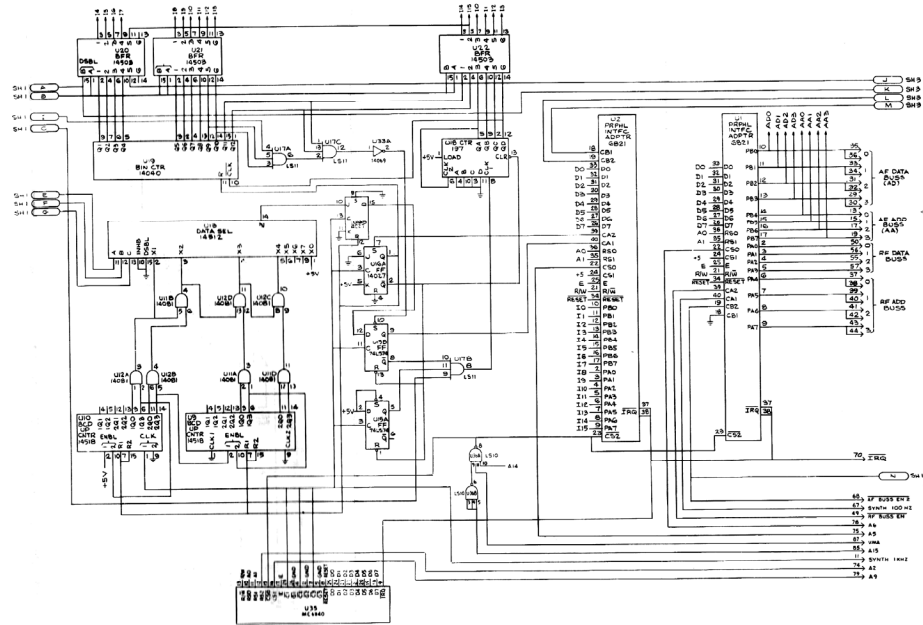

Figure 13-2: Processor I/O A7
Schematic Diagram
(Sheet 2 of 3)

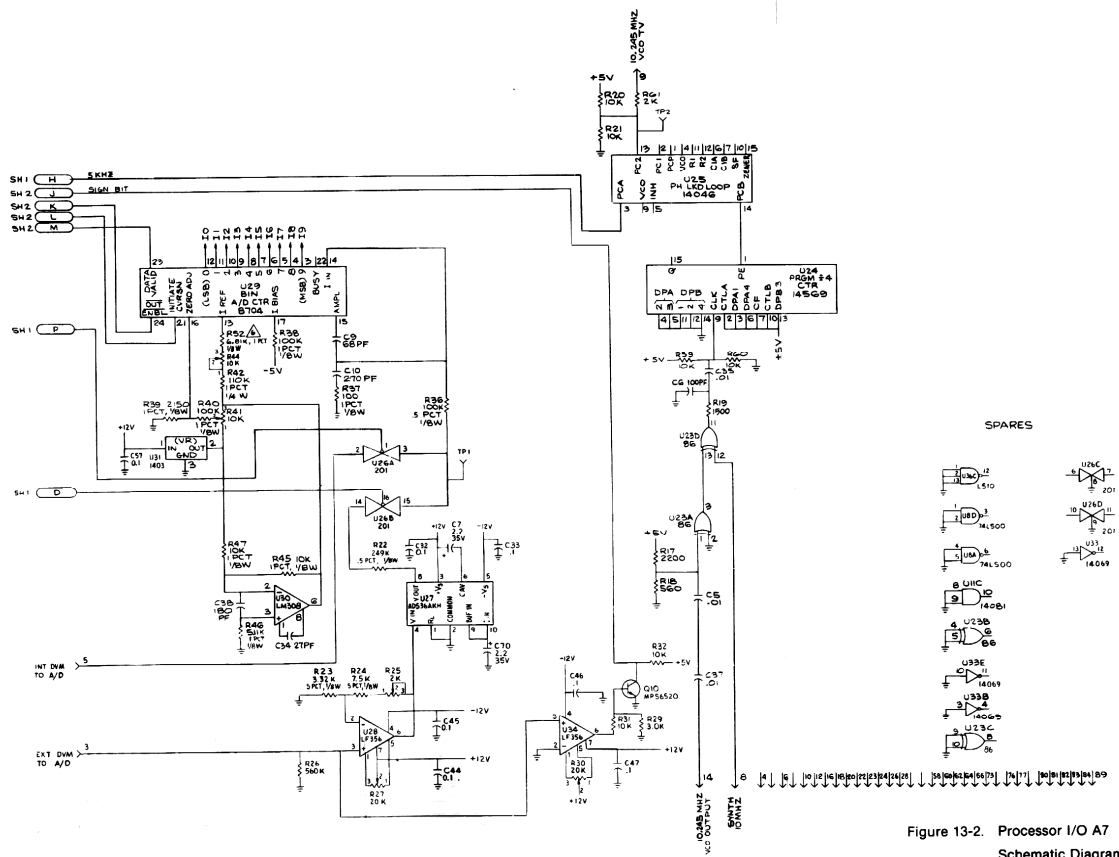
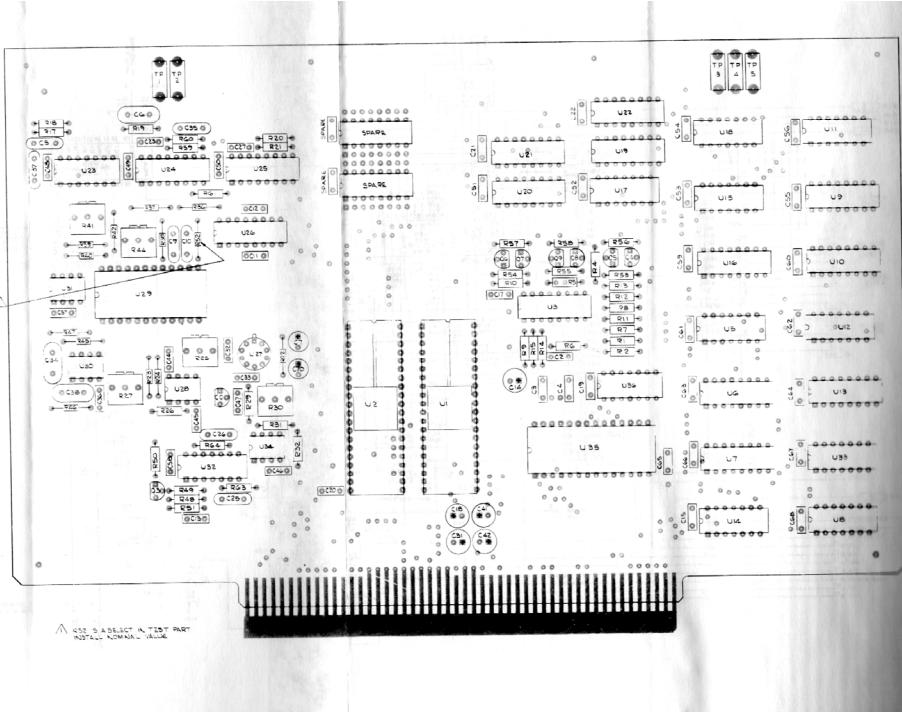

Figure 13-2: Processor I/O A7
Schematic Diagram
(Sheet 3 of 3)



Please check the quality of this scan; this section of the manual was fully designed as well several other sections. If you find errors, please contact us.

Figure 13-3. Processor I/O A7 (RTC-4025A)
Parts Location Diagram
(Sheet 1 of 2)

Find No.	Qty. Req.	Part No.	Nomenclature	Part Value	Find No.	Qty. Req.	Part No.	Nomenclature	Part Value	Find No.	Qty. Req.	Part No.	Nomenclature	Part Value
PROCESSOR I/O														
001	1	RTC-4025A	PROCESSOR I/O		C 066	1	21-80398A2	CAPACITOR	1UF 20-100	R 058	1	65124A14	RESISTOR	36.5-1.4
003	AR	540599P5	PWB PROCESSOR I/O		C 067	1	21-80398A2	CAPACITOR	1UF 20-100	R 060	1	65124A12	RESISTOR	10K-5-1.4
006	AR	11-14161A0	W/B	BLACK	C 068	1	21-80398A2	CAPACITOR	1UF 20-100	R 061	1	65124A12	RESISTOR	10K-5-1.4
005	1	07-80354B3	BRACKET PWB M/TG		C 070	1	23-3026A34	CAPACITOR	2.2UF 20-35	R 063	1	65124A06	RESISTOR	2.0K-5-1.4
006	4	1402073A6L8	PIVET	1.8X.312	O 003	1	48-80398A1	TRANSISTOR	MPS819 SCREENED	R 064	1	65124A11	RESISTOR	2.2K-5-1.4
007	2	3C6500003	EYELET		O 004	1	48-80398A2	TRANSISTOR	MPS819 SCREENED	R 064	1	65124A18	RESISTOR	300.5-1.4
008	2	4C0C849B01	RETAINER		O 005	1	48-80398A2	TRANSISTOR	MPS819 SCREENED	TP001	1	08-80331A88	JACK TIP	WHT
009	2	05-1308F1	SCREENING	4.0X.312	O 006	1	48-80398A2	TRANSISTOR	MPS819 SCREENED	TP002	1	08-80331A88	JACK TIP	WHT
C 002	1	21-80398A2	CAPACITOR	1UF 20-100	O 007	1	48-80398A2	TRANSISTOR	MPS819 SCREENED	TP003	1	08-80331A88	JACK TIP	WHT
C 003	1	21-80398A2	CAPACITOR	1UF 20-100	O 008	1	48-80398A2	TRANSISTOR	MPS819 SCREENED	TP004	1	08-80331A88	JACK TIP	WHT
C 004	1	21-80398A2	CAPACITOR	1UF 20-100	O 009	1	48-80398A2	TRANSISTOR	MPS819 SCREENED	TP005	1	08-80331A88	JACK TIP	WHT
C 005	1	21-80398A2	CAPACITOR	01UF 20-80-200	O 010	1	48-80398A1	TRANSISTOR	MPS820 SCREENED	U 001	1	51-80368A72	INTEGRATED CIRCUIT	MC821P SCREENED
C 006	1	21D8494B04	CAPACITOR	100PF 5-500	R 001	1	65124A35	RESISTOR	270.5-1.4	U 002	1	51-80368A72	INTEGRATED CIRCUIT	MC821P SCREENED
C 007	1	23-3026A34	CAPACITOR	2.2UF 20-35	R 002	1	65124A35	RESISTOR	270.5-1.4	U 003	1	51-80368A80	INTEGRATED CIRCUIT	MC10429 SCREENED
C 008	1	21-80398A2	CAPACITOR	1UF 20-100	R 003	1	65124A42	RESISTOR	510.5-1.4	U 005	1	51-80368A44	INTEGRATED CIRCUIT	MC1429BCP SCREENED
C 009	1	21-80398A2	CAPACITOR	1UF 20-100	R 004	1	65124A42	RESISTOR	510.5-1.4	U 006	1	51-80368A58	INTEGRATED CIRCUIT	MC140429 SCREENED
C 010	1	21D8187B04	CAPACITOR	270PF 10-500	R 005	1	65124A41	RESISTOR	470.5-1.4	U 007	1	51-80368A58	INTEGRATED CIRCUIT	MC140429 SCREENED
C 011	1	21-80398A2	CAPACITOR	1UF 20-100	R 006	1	65124A41	RESISTOR	470.5-1.4	U 008	1	51-80368A09	INTEGRATED CIRCUIT	SN743000P SCREENED
C 012	1	21-80398A2	CAPACITOR	1UF 20-100	R 007	1	65124A38	RESISTOR	300.5-1.4	U 009	1	51-80368A50	INTEGRATED CIRCUIT	MC14518BCP SCREENED
C 013	1	21-80398A2	CAPACITOR	1UF 20-100	R 008	1	65124A38	RESISTOR	300.5-1.4	U 010	1	51-80368A50	INTEGRATED CIRCUIT	MC14518BCP SCREENED
C 014	1	21-80398A2	CAPACITOR	1UF 20-100	R 009	1	65124A42	RESISTOR	510.5-1.4	U 011	1	51-80368A45	INTEGRATED CIRCUIT	MC14081BCP SCREENED
C 015	1	21-80398A2	CAPACITOR	1UF 20-100	R 010	1	65124A42	RESISTOR	510.5-1.4	U 012	1	51-80368A45	INTEGRATED CIRCUIT	MC14081BCP SCREENED
C 017	1	21-80398A2	CAPACITOR	1UF 20-100	R 011	1	65124A41	RESISTOR	470.5-1.4	U 013	1	51-80368A48	INTEGRATED CIRCUIT	MC145120CP SCREENED
C 018	1	21-80398A2	CAPACITOR	1UF 20-100	R 012	1	65124A48	RESISTOR	500.5-1.4	U 014	1	51-80368A09	INTEGRATED CIRCUIT	SN743000P SCREENED
C 019	1	21-80398A2	CAPACITOR	1UF 20-100	R 013	1	65124A38	RESISTOR	300.5-1.4	U 015	1	51-80368A24	INTEGRATED CIRCUIT	SN74324NS SCREENED
C 020	1	21-80398A2	CAPACITOR	1UF 20-100	R 014	1	65124A42	RESISTOR	510.5-1.4	U 016	1	51-80368A34	INTEGRATED CIRCUIT	SN74318NS SCREENED
C 021	1	21-80398A2	CAPACITOR	1UF 20-100	R 015	1	65124A42	RESISTOR	510.5-1.4	U 017	1	51-80368A58	INTEGRATED CIRCUIT	SN74318NS SCREENED
C 022	1	21-80398A2	CAPACITOR	1UF 20-100	R 017	1	65124A37	RESISTOR	2.2K-5-1.4	U 018	1	51-80368A75	INTEGRATED CIRCUIT	SN74318NS SCREENED
C 023	1	21-80398A2	CAPACITOR	1UF 20-100	R 018	1	65124A37	RESISTOR	2.2K-5-1.4	U 019	1	51-80368A35	INTEGRATED CIRCUIT	MC140820CP SCREENED
C 025	1	21-80398A2	CAPACITOR	01UF 20-80-200	R 019	1	65124A33	RESISTOR	1.5K-5-1.4	U 020	1	51-80368A47	INTEGRATED CIRCUIT	MC140820CP SCREENED
C 026	1	21-80398A2	CAPACITOR	01UF 20-80-200	R 020	1	65124A73	RESISTOR	10K-5-1.4	U 021	1	51-80368A47	INTEGRATED CIRCUIT	MC140820CP SCREENED
C 027	1	21-80398A2	CAPACITOR	1UF 20-100	R 021	1	65124A73	RESISTOR	10K-5-1.4	U 022	1	51-80368A47	INTEGRATED CIRCUIT	MC140820CP SCREENED
C 028	1	21-80398A2	CAPACITOR	1UF 20-100	R 022	1	08-80398A46	RESISTOR	20K-5-1.8	U 023	1	51-80368A25	INTEGRATED CIRCUIT	SN743000P SCREENED
C 029	1	21-80398A2	CAPACITOR	1UF 20-100	R 023	1	08-80398A47	RESISTOR	3.2K-5-1.8	U 024	1	51-80368A47	INTEGRATED CIRCUIT	MC140820CP SCREENED
C 030	1	21-80398A2	CAPACITOR	1UF 20-100	R 024	1	08-80398A49	RESISTOR	7.5K-5-1.8	U 025	1	51-80368A19	INTEGRATED CIRCUIT	MC140820CP SCREENED
C 031	1	23-3026A34	CAPACITOR	270PF 5-500	R 025	1	1808150P13	RESISTOR VARIABLE	20K	U 026	1	51-80368A19	INTEGRATED CIRCUIT	MC140820CP SCREENED
C 032	1	21-80398A2	CAPACITOR	1UF 20-100	R 026	1	65124B16	RESISTOR	50K-5-1.4	U 027	1	51-80368A17	INTEGRATED CIRCUIT	MC140820CP SCREENED
C 033	1	21-80398A2	CAPACITOR	1UF 20-100	R 027	1	1808150P15	RESISTOR VARIABLE	20K	U 028	1	51-80368A17	INTEGRATED CIRCUIT	MC140820CP SCREENED
C 034	1	21D8494B02	CAPACITOR	100PF 5-500	R 028	1	65124A60	RESISTOR	3.3K-5-1.4	U 029	1	51-80368A17	INTEGRATED CIRCUIT	MC140820CP SCREENED
C 035	1	21-80398A2	CAPACITOR	1UF 20-100	R 029	1	1808150P15	RESISTOR VARIABLE	20K	U 030	1	51-80368A17	INTEGRATED CIRCUIT	MC140820CP SCREENED
C 036	1	21-80398A2	CAPACITOR	1UF 20-100	R 030	1	1808150P15	RESISTOR VARIABLE	20K	U 031	1	51-80368A17	INTEGRATED CIRCUIT	MC140820CP SCREENED
C 037	1	21-80398A2	CAPACITOR	1UF 20-100	R 031	1	65124A77	RESISTOR	10K-5-1.4	U 032	1	51-80368A17	INTEGRATED CIRCUIT	MC140820CP SCREENED
C 038	1	21D8494B06	CAPACITOR	100PF 5-500	R 032	1	65124A73	RESISTOR	10K-5-1.4	U 033	1	51-80368A17	INTEGRATED CIRCUIT	MC140820CP SCREENED
C 041	1	23-3026A34	CAPACITOR	270PF 5-500	R 033	1	65124A73	RESISTOR	10K-5-1.4	U 034	1	51-80368A17	INTEGRATED CIRCUIT	MC140820CP SCREENED
C 042	1	21-80398A2	CAPACITOR	1UF 20-100	R 034	1	08-80398A59	RESISTOR	100K-5-1.8	U 035	1	51-80368A17	INTEGRATED CIRCUIT	MC140820CP SCREENED
C 043	1	21-80398A2	CAPACITOR	1UF 20-100	R 037	1	08-108150P1	RESISTOR	10K-1-1.8	U 036	1	51-80368A17	INTEGRATED CIRCUIT	MC140820CP SCREENED
C 044	1	21-80398A2	CAPACITOR	1UF 20-100	R 038	1	08-108150P1	RESISTOR	10K-1-1.8	U 037	1	51-80368A17	INTEGRATED CIRCUIT	MC140820CP SCREENED
C 045	1	21-80398A2	CAPACITOR	1UF 20-100	R 039	1	08-108150P1	RESISTOR	10K-1-1.8	U 038	1	51-80368A17	INTEGRATED CIRCUIT	MC140820CP SCREENED
C 046	1	21-80398A2	CAPACITOR	1UF 20-100	R 040	1	08-108150P1	RESISTOR	10K-1-1.8	U 039	1	51-80368A17	INTEGRATED CIRCUIT	MC140820CP SCREENED
C 047	1	21-80398A2	CAPACITOR	1UF 20-100	R 041	1	08-108150P1	RESISTOR	10K-1-1.8	U 040	1	51-80368A17	INTEGRATED CIRCUIT	MC140820CP SCREENED
C 048	1	21-80398A2	CAPACITOR	1UF 20-100	R 042	1	08-108150P1	RESISTOR	10K-1-1.8	U 041	1	51-80368A17	INTEGRATED CIRCUIT	MC140820CP SCREENED
C 049	1	21-80398A2	CAPACITOR	1UF 20-100	R 043	1	1808150P13	RESISTOR VARIABLE	10K	U 042	1	51-80368A17	INTEGRATED CIRCUIT	MC140820CP SCREENED
C 050	1	21-80398A2	CAPACITOR	1UF 20-100	R 044	1	08-80398A75	RESISTOR	10K-1-1.4	U 043	1	51-80368A17	INTEGRATED CIRCUIT	MC140820CP SCREENED
C 051	1	21-80398A2	CAPACITOR	1UF 20-100	R 045	1	1808150P13	RESISTOR VARIABLE	10K	U 044	1	51-80368A17	INTEGRATED CIRCUIT	MC140820CP SCREENED
C 052	1	21-80398A2	CAPACITOR	1UF 20-100	R 046	1	08-108150P1	RESISTOR	10K-1-1.8	U 045	1	51-80368A17	INTEGRATED CIRCUIT	MC140820CP SCREENED
C 053	1	21-80398A2	CAPACITOR	1UF 20-100	R 047	1	08-108150P1	RESISTOR	10K-1-1.8	U 046	1	51-80368A17	INTEGRATED CIRCUIT	MC140820CP SCREENED
C 054	1	21-80398A2	CAPACITOR	1UF 20-100	R 048	1	65124B16	RESISTOR	50K-5-1.4	U 047	1	51-80368A17	INTEGRATED CIRCUIT	MC140820CP SCREENED
C 055	1	21-80398A2	CAPACITOR	1UF 20-100	R 049	1	65124A49	RESISTOR	1K-5-1.4	U 048	1	51-80368A17	INTEGRATED CIRCUIT	MC140820CP SCREENED
C 056	1	21-80398A2	CAPACITOR	1UF 20-100	R 050	1	65124A52	RESISTOR	100.5-1.4	U 049	1	51-80368A17	INTEGRATED CIRCUIT	MC140820CP SCREENED
C 057	1	21-80398A2	CAPACITOR	1UF 20-100	R 051	1	65124A87	RESISTOR	100K-5-1.4	U 050	1	51-80368A17	INTEGRATED CIRCUIT	MC140820CP SCREENED
C 058	1	21-80398A2	CAPACITOR	1UF 20-100	R 052	1	08-80295F5	RESISTOR	680-1-1.8 NOMINAL	U 051	1	51-80368A17	INTEGRATED CIRCUIT	MC140820CP SCREENED
C 059	1	21-80398A2	CAPACITOR	1UF 20-100	R 052	AR	08-80295F5	RESISTOR	680-1-1.8 NOMINAL	U 052	1	51-80368A17	INTEGRATED CIRCUIT	MC140820CP SCREENED
C 060	1	21-80398A2	CAPACITOR	1UF 20-100	R 053	1	65124A29	RESISTOR	100.5-1.4	U 053	1	51-80368A17	INTEGRATED CIRCUIT	MC140820CP SCREENED
C 061	1	21-80398A2	CAPACITOR	1UF 20-100	R 054	1	65124A29	RESISTOR	100.5-1.4	U 054	1	51-80368A17	INTEGRATED CIRCUIT	MC140820CP SCREENED
C 062	1	21-80398A2	CAPACITOR	1UF 20-100	R 055	1	65124A29	RESISTOR	100.5-1.4	U 055	1	51-80368A17	INTEGRATED CIRCUIT	MC140820CP SCREENED
C 063	1	21-80398A2	CAPACITOR	1UF 20-100	R 056	1	65124A14	RESISTOR	36.5-1.4	U 056	1	51-80368A17	INTEGRATED CIRCUIT	

SECTION 14

IEEE INTERFACE MODULE (A8)

14-1. General. Remote control of the system is possible using a IEEE-488 bus and the IEEE Interface Module. The Interface Module provides the interface for the 488 bus and provides for processor control of most of the functions normally controlled from the front panel. A block diagram of the IEEE Interface Module is shown in figure 14-1 with its schematic shown in figure 14-2. See section 21 for information on the use of the IEEE Bus for system control.

14-2. IEEE Bus Interface. Bus buffering and interface protocol as defined by the IEEE-488 specification is provided for by the IEEE Bus Interface circuit. The system processor accesses the interface directly through its address, data, and control buses for reading from or writing to the IEEE bus.

14-3. RF Level Control. The RF Level Control circuitry selects between the 5 VDC + AM MOD or the AM MOD + DC REF (I) input for remote or local control respectively. For remote control the 5 VDC + AM MOD input is electronically attenuated to provide the requested RF output level. For local control the attenuator is programmed for unity gain so that the AM MOD + DC REF (I) signal from the front panel RF level potentiometer controls the RF output level.

14-4. For the IEEE control option, a electronically programmable RF step attenuator is installed in the system. Control of the attenuator is then from the processor through the Address Decode and Control Latch circuitry on the Interface Module.

14-5. Modulation Control. Each of the three modulation sources are individually controllable by the IEEE Bus Interface module. For remote control the respective modulation input (INT MOD (I), EXT MOD (I), and 1 kHz SINE) is switched to a programmable attenuator. The system processor selects the level of attenuation necessary to provide the requested level of modulation. For local control the attenuators are programmed for unity gain and the respective modulation signal from the front panel level control (INT MOD RTN (I), EXT MOD RTN (I), and 1 kHz SINE RTN (I)) is selected to the attenuator to provide modulation level control.

14-6. Address Decode and Control Latches. The system processor has direct control over the programmable attenuators on the module with the Address Decode and Control Latch circuitry. Control data on the data bus (D0-D7) is latched at the Control Latch indicated by the address bus (A0-A15).

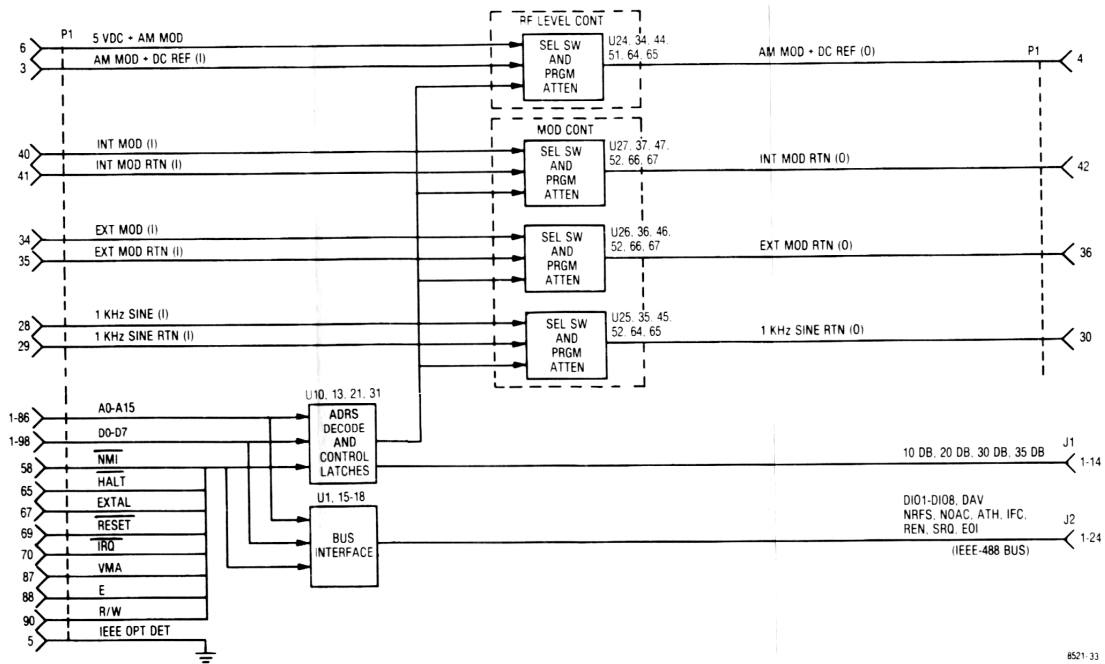

8521-33

Figure 14-1. IEEE Interface Module A8
Block Diagram

1. SEE THE "IEEE-488 BUS" SECTION OF THE "IEEE-488 BUS" MANUAL FOR A COMPLETE LIST OF SIGNALS AND THEIR FUNCTIONS.
 2. THE "IEEE-488 BUS" MANUAL IS AVAILABLE FROM THE "IEEE-488 BUS" MANUAL PUBLISHERS.
 3. THE "IEEE-488 BUS" MANUAL IS AVAILABLE FROM THE "IEEE-488 BUS" MANUAL PUBLISHERS.

REF	SYMBOL	DESCRIPTION	UNIT	VALUE	TYPE	LOCATION
U1	15-18	BUS INTERFACE	IC			15-18
U10	13, 21, 31	ADRS DECODE AND CONTROL LATCHES	IC			13, 21, 31
U24	34, 44, 51, 64, 65	SEL SW AND PRGM ATTN	IC			34, 44, 51, 64, 65
U27	37, 47, 52, 66, 67	SEL SW AND PRGM ATTN	IC			37, 47, 52, 66, 67
U26	36, 46, 52, 66, 67	SEL SW AND PRGM ATTN	IC			36, 46, 52, 66, 67
U25	35, 45, 52, 64, 65	SEL SW AND PRGM ATTN	IC			35, 45, 52, 64, 65

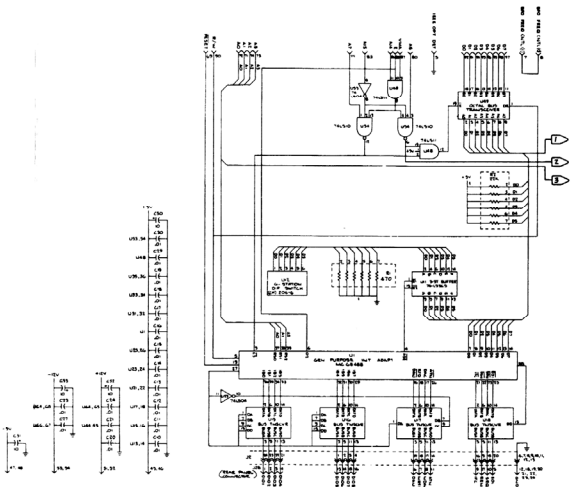

Figure 14-2. IEEE Interface Module A8
Schematic Diagram (Sheet 1 of 2)

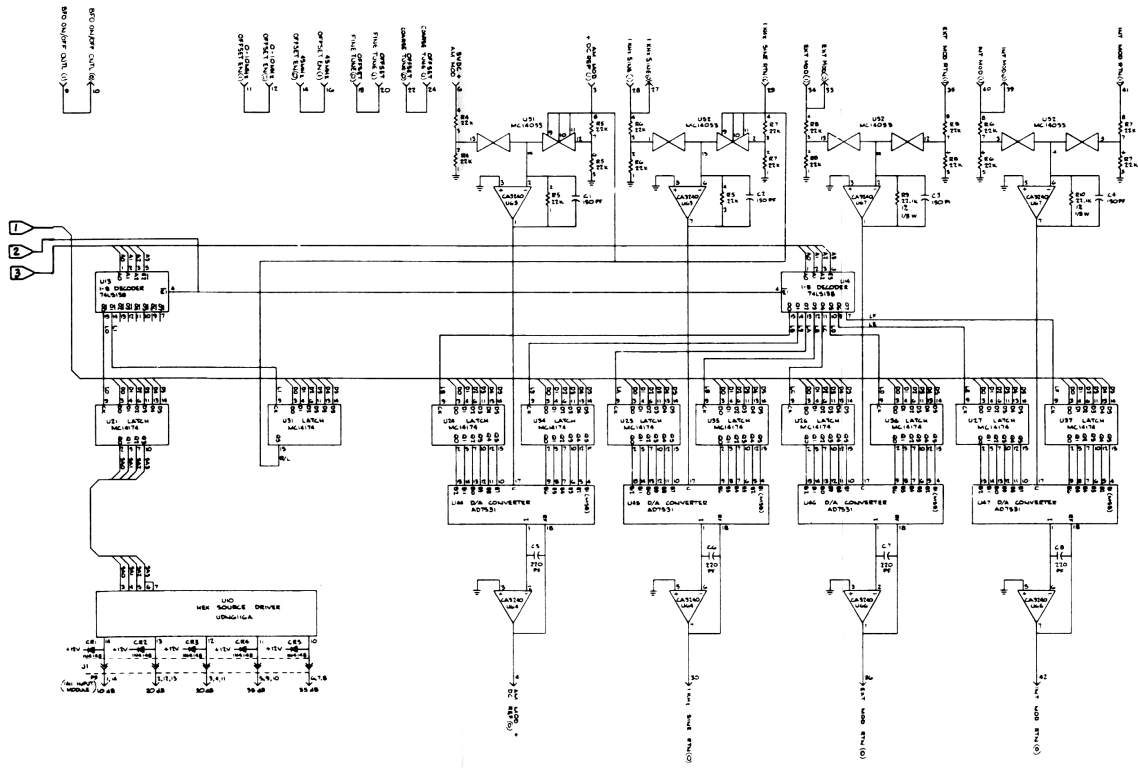

Figure 14-2. IEEE Interface Module A8
Schematic Diagram (Sheet 2 of 2)

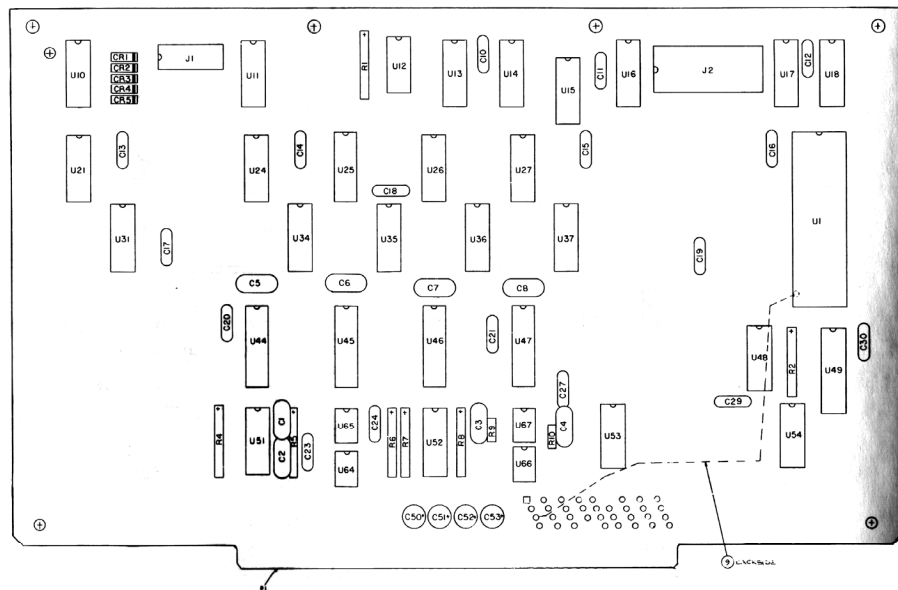

Figure 14-3. IEEE Interface Module A8
(RTC-4013B) Parts Location
Diagram (Sheet 1 of 2)

Find No.	Qty. Req.	Part No.	Nomenclature	Part Value	Find No.	Qty. Req.	Part No.	Nomenclature	Part Value
		RTC-4013B	IEEE INTERFACE		R 010	1	06-10621D25	RESISTOR	22 1K-1-1-8
001	1	84-P00204N001	PWB IEEE INTERFACE		U 001	1	51-80346A52	INTEGRATED CIRCUIT	MC68488P SCREENED
002	AR	SN63VRMAP3	SOLDER		U 010	1	51-80346A63	INTEGRATED CIRCUIT	
003	AR	11 14167A01	INK	BLACK	U 011	1	51-80345A31	INTEGRATED CIRCUIT	SN74LS365N SCREENED
004	1	07-80335A63	BRACKET PWB MTG		U 012	1	40-80369A07	SWITCH	
005	4	MS20470AD4-5	RIVET	1 BX 312	U 013	1	51-80346A57	INTEGRATED CIRCUIT	SN74LS138N SCREENED
006	2	5C84500B03	EYELET		U 014	1	51-80346A57	INTEGRATED CIRCUIT	SN74LS138N SCREENED
007	2	42C84284B01	RETAINER		U 015	1	51-80346A51	INTEGRATED CIRCUIT	MC3448 SCREENED
008	2	03-139581	SCREW PH	4.40X 312	U 016	1	51-80346A51	INTEGRATED CIRCUIT	MC3448 SCREENED
009	AR		WIRE	#26	U 017	1	51-80346A51	INTEGRATED CIRCUIT	MC3448 SCREENED
C 001	1	21D82187B49	CAPACITOR	150PF-10-500	U 018	1	51-80346A51	INTEGRATED CIRCUIT	MC3448 SCREENED
C 002	1	21D82187B49	CAPACITOR	150PF-10-500	U 021	1	51-80346A50	INTEGRATED CIRCUIT	MC14174BCP SCREENED
C 003	1	21D82187B49	CAPACITOR	150PF-10-500	U 024	1	51-80346A50	INTEGRATED CIRCUIT	MC14174BCP SCREENED
C 004	1	21D82187B49	CAPACITOR	150PF-10-500	U 025	1	51-80346A50	INTEGRATED CIRCUIT	MC14174BCP SCREENED
C 005	1	21D82187B08	CAPACITOR	220PF-10-500	U 026	1	51-80346A50	INTEGRATED CIRCUIT	MC14174BCP SCREENED
C 006	1	21D82187B08	CAPACITOR	220PF-10-500	U 027	1	51-80346A50	INTEGRATED CIRCUIT	MC14174BCP SCREENED
C 007	1	21D82187B08	CAPACITOR	220PF-10-500	U 031	1	51-80346A50	INTEGRATED CIRCUIT	MC14174BCP SCREENED
C 008	1	21D82187B08	CAPACITOR	220PF-10-500	U 034	1	51-80346A50	INTEGRATED CIRCUIT	MC14174BCP SCREENED
C 010	1	21-80396A52	CAPACITOR	01UF-20 + 80-200	U 035	1	51-80346A50	INTEGRATED CIRCUIT	MC14174BCP SCREENED
C 011	1	21-80396A52	CAPACITOR	01UF-20 + 80-200	U 036	1	51-80346A50	INTEGRATED CIRCUIT	MC14174BCP SCREENED
C 012	1	21-80396A52	CAPACITOR	01UF-20 + 80-200	U 037	1	51-80346A50	INTEGRATED CIRCUIT	MC14174BCP SCREENED
C 013	1	21-80396A52	CAPACITOR	01UF-20 + 80-200	U 044	1	51-80345A98	INTEGRATED CIRCUIT	AD7531JPN SCREENED
C 014	1	21-80396A52	CAPACITOR	01UF-20 + 80-200	U 045	1	51-80345A98	INTEGRATED CIRCUIT	AD7531JPN SCREENED
C 015	1	21-80396A52	CAPACITOR	01UF-20 + 80-200	U 046	1	51-80345A98	INTEGRATED CIRCUIT	AD7531JPN SCREENED
C 016	1	21-80396A52	CAPACITOR	01UF-20 + 80-200	U 047	1	51-80345A98	INTEGRATED CIRCUIT	AD7531JPN SCREENED
C 017	1	21-80396A52	CAPACITOR	01UF-20 + 80-200	U 048	1	51-80346A56	INTEGRATED CIRCUIT	SN74LS11N SCREENED
C 018	1	21-80396A52	CAPACITOR	01UF-20 + 80-200	U 049	1	51-80366A20	INTEGRATED CIRCUIT	SN74LS249NS SCREENED
C 019	1	21-80396A52	CAPACITOR	01UF-20 + 80-200	U 051	1	51-80368A39	INTEGRATED CIRCUIT	MC14053BCP SCREENED
C 020	1	21-80396A52	CAPACITOR	01UF-20 + 80-200	U 052	1	51-80368A39	INTEGRATED CIRCUIT	MC14053BCP SCREENED
C 021	1	21-80396A52	CAPACITOR	01UF-20 + 80-200	U 053	1	51-80368A11	INTEGRATED CIRCUIT	SN74LS04NS SCREENED
C 023	1	21-80396A52	CAPACITOR	01UF-20 + 80-200	U 054	1	51-80346A55	INTEGRATED CIRCUIT	SN74LS10N SCREENED
C 024	1	21-80396A52	CAPACITOR	01UF-20 + 80-200	U 064	1	51-80345A04	INTEGRATED CIRCUIT	CA3240E SCREENED
C 027	1	21-80396A52	CAPACITOR	01UF-20 + 80-200	U 065	1	51-80345A04	INTEGRATED CIRCUIT	CA3240E SCREENED
C 029	1	21-80396A52	CAPACITOR	01UF-20 + 80-200	U 066	1	51-80345A04	INTEGRATED CIRCUIT	CA3240E SCREENED
C 030	1	21-80396A52	CAPACITOR	01UF-20 + 80-200	U 067	1	51-80345A04	INTEGRATED CIRCUIT	CA3240E SCREENED
C 050	1	23-80396A40	CAPACITOR	10UF-25V					
C 051	1	23-80396A40	CAPACITOR	10UF-25V					
C 052	1	23-80396A40	CAPACITOR	10UF-25V					
C 053	1	23-80396A40	CAPACITOR	10UF-25V					
CR001	1	48-84463K02	DIODE						
CR002	1	48-84463K02	DIODE						
CR003	1	48-84463K02	DIODE						
CR004	1	48-84463K02	DIODE						
CR005	1	48-84463K02	DIODE						
J 001	1	09-80313A09	SOCKET	14 PIN					
J 002	1	09-80331A86	SOCKET	24 PIN					
R 001	1	51-80396A22	RESISTOR NETWORK	HEX SIP 470 OHM					
R 002	1	51-80368A77	RESISTOR NETWORK	HEX SIP					
R 004	1	51-80368A78	RESISTOR NETWORK	QUAD SIP					
R 005	1	51-80368A78	RESISTOR NETWORK	QUAD SIP					
R 006	1	51-80368A78	RESISTOR NETWORK	QUAD SIP					
R 007	1	51-80368A78	RESISTOR NETWORK	QUAD SIP					
R 008	1	51-80368A78	RESISTOR NETWORK	QUAD SIP					
R 009	1	06-10621D25	RESISTOR	22 1K-1-1-8					

Figure 14-3. IEEE Interface Module A8 (RTC-4013B) Parts Location Diagram (Sheet 2 of 2)

SECTION 15 PROCESSOR MODULE (A9)

15-1. GENERAL. The processor module provides primary control and data manipulations for the system. This module contains a processor and buffer, a program memory (ROM), a nonvolatile memory (NVM), a random access memory (RAM), a peripheral interface adapter (PIA), a timing generator, and a character generator. Input and output information is via the peripheral interface adapter and the address, data, and control buses. A block diagram and a schematic diagram of the module is shown in figure 15-1 and figure 15-2, respectively.

15.2 PROCESSOR AND BUFFER. The processor is a Motorola microprocessor MC6802, operating at a 1 MHz clock rate. This microprocessor controls the processor module via the three signal buses. The address bus provides access to the selected device for data transfers (read/write) from the data bus. Synchronization of the data transfer and specialized processor functions are provided through the control bus.

15-3. PROGRAM MEMORY (ROM). The series of commands (program instructions) that direct microprocessor action are contained in the ROM (Read Only Memory). This ROM is comprised of two 8192×8 -bit read only memories. An additional 8192×8 -bit read only memory is provided with the IEEE option.

15-4. NONVOLATILE MEMORY (NVM). The nonvolatile memory provides storage for 1024 four-bit words. Data that is to be held during power off is held in the NVM, which consists of a battery backed RAM (Random Access Memory). When the power is turned on, the microprocessor reads the NVM contents to obtain its start up mode, the RF and tone memory presets, and the remainder of the preset data. If the operator changes a preset, the microprocessor changes the data in the NVM so that the new preset will be remembered.

15-5. RANDOM ACCESS MEMORY (RAM). The random access memory provides temporary storage for both the processor and the CRT alphanumeric display. The RAM has provision to store 1024 eight-bit words, of which 512 are used for the CRT display data. Data is written into and read out of the RAM by the microprocessor.

15-6. PERIPHERAL INTERFACE ADAPTER (PIA). The peripheral interface adapter provides input and output latches for external data from/to the processor module. There are nine inputs from the keyboard, four column inputs (KYBD COL 0-3), and five row inputs (KYBD ROW 0-4). A single input (IEEE OPT DET) signals the processor that the IEEE option is installed. The AF BUS EN 1 output signal synchronizes the transfer of data on the system AF control bus.

15-7. TIMING GENERATOR. The timing generator provides the timing signals for the character generator. All of the timing signals are synchronized to the 1 MHz master clock signal from the processor. A x2 multiplier provides a 2 MHz clock to the 8-bit shift register, which in turn provides the dot clock. Additionally, the 1 MHz is successively divided through a divide-by-four circuit then through a 12-binary counter to provide the remaining clock requirements.

15-8. CHARACTER GENERATOR. The character generator sequentially accesses that part of the RAM where character information is stored and causes the respective characters to be displayed on the screen. Since both the character generator and the processor share the same RAM, the two must be synchronized so they access the RAM during alternate half cycles of the master clock. The 1 MHz master clock signal, from the processor is used to synchronize the 2 MHz dot clock.

15-9. Characters are displayed on the CRT as eight-by-eight dot matrices. Thirty-two dot matrices, of which the last two are always blank, make one character line. Sixteen lines, of which the last line is always blank, complete the display area. Therefore, the total number of matrices available for character display is 30×15 or 450 matrices. The blank matrices and the blank line are used for horizontal and vertical retrace blanking, respectively. The display is generated by dot rows. As the CRT sweeps the first dot row of a character line, the character generator outputs a serial bit pattern of 1's and 0's that turn the crt intensity on and off. The result is a row of dots that when combined with the next seven rows form a character.

15-10. A select switch, on the data and address buses to the RAM, toggles at the master clock rate of 1 MHz. This results in the processor and the character generator having access to the RAM alternately every other 0.5 microseconds. The processor stores in the RAM an 8-bit word that represent the character to be displayed. The character generator scans the RAM in sequence with the CRT display scan. As each location in the RAM is addressed, the 8-bit word stored at that location is latched by the 8-bit latch. Seven of the bits in the latch are applied to the character ROM, the eighth bit is not used. The timing generator provides 3 bits which indicates which row of dots are being scanned. The 10 bits applied to the character ROM, define a specific dot row of a particular character. An 8-bit pattern, defining that row of the character, is parallel loaded into the 8-bit shift register. These 8 bits are serially shifted out of the register, at a 2 MHz rate, as the CHAR GEN Z-AXIS output signal.

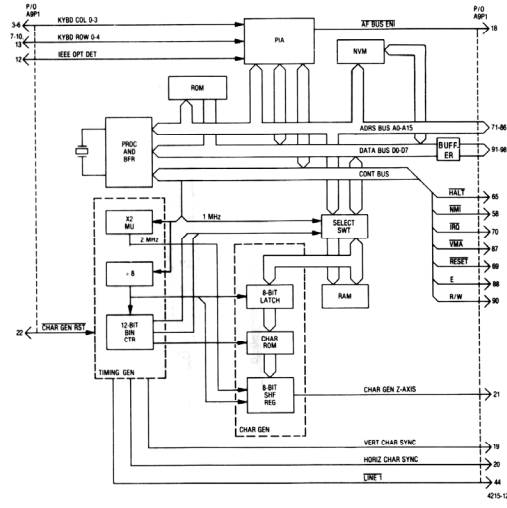

Figure 15-1. Processor Module A9 Block Diagram

15.2

- NOTES:
1. PARTIAL REFERENCE DESIGNATIONS ARE SHOWN. FOR COMPLETE DESIGNATION PREFIX WITH AS.
 2. FOR REFERENCE DRAWINGS REFER TO: 85-568-1 01 P14 65 A P14 65 B 04 P24 10 5 A
 3. UNLESS OTHERWISE SPECIFIED: ALL RESISTORS ARE IN OHMS, 5% PCT. UNLESS NOTED. ALL CAPACITORS ARE IN UF. ALL VOLTAGES ARE IN V.
 4. DEVICE TYPE AND CONNECTIONS NOT SHOWN ON SYMBOL ARE LISTED IN TABLE 1. UNDERLINE PORTION OF TYPE NUMBER IS USED AS A CODE TO IDENTIFY DEVICES ON DIAGRAM.

- ⚠ U3 IS USED FOR IEEE CONFIGURATION ONLY.
 - ⚠ U9 IS OPTIONAL
 - ⚠ U37 IS OPTIONAL
 - ⚠ P10 IS USED WITH LIB FOR IEEE CONFIGURATION ONLY.
- EPRM MCM2552
MUST BE PROGRAMMED WITH DATA PER IEEE PROGRAM 98-1 P20000A

REF DESIGNATIONS	
HIGHEST USED	NOT USED
BT 1	
C54	D16, L23, C70, C55
CR 5	
R 27	RB
TP12	
U42 *	U4
Y1	
F1	

* SEE TABLE 1

TABLE 1				
REF DES	DEVICE TYPE	GND	+5V	NO CONNECTION
U1	74LS221	8	16	3 4 12 13 14 15
U2	74LS16	7	14	12
U3	74LS244	7	14	4 6 10
U4	<u>NOT USED</u>			
U5	74LS191	8	16	13
U6	MCM4835P35	12	24	
U7	MCM4835P35	12	24	
U8	MCM2552	12	24	
U9	MCM2714	12	24	
U10	74LS393	7	14	
U11	74LS374	10	20	19
U12	64562	12	24	
U13	74LS168	8	16	
U14	MCM802	11, 21	8, 35	7
U15	74LS123	8	16	4 5
U16	74LS221	8	16	4 12
U17	74LS04	7	14	4 10, 12
U18	74LS240	7	14	
U19	74LS24	7	14	
U20	74LS24	7	14	6, 8, 9, 11, 12
U21	74LS24	7	14	2
U22	MCM821	1	20	
U23	74LS139	8	16	9 10 11 12
U24	74LS167	8	16	
U25	74LS157	8	16	12
U26	74LS157	8	16	12
U27	MCM2114	9	18	
U28	MCM2114	9	18	
U29	74LS245	10	20	
U30	74LS245	10	20	
U31	74LS125	7	14	
U32	74LS20	7	14	3 11
U33	74LS00	7	14	
U34	74LS123	8	16	5 13
U35	MCM4088B	7		
U36	6514	9		
U37	6514	9		
U38	74LS244	10	20	
U39	74LS244	10	20	
U40	74LS245	10	20	
U41	74LS27	7	14	
U42	74LS244	7	14	

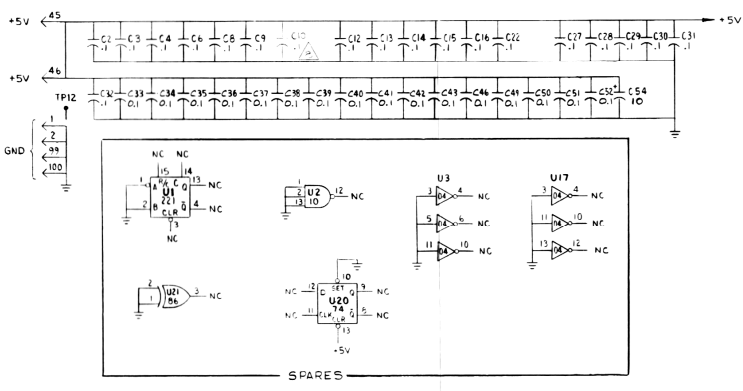

Figure 15-2. Processor Module A9 Schematic Diagram (Sheet 1 of 7)

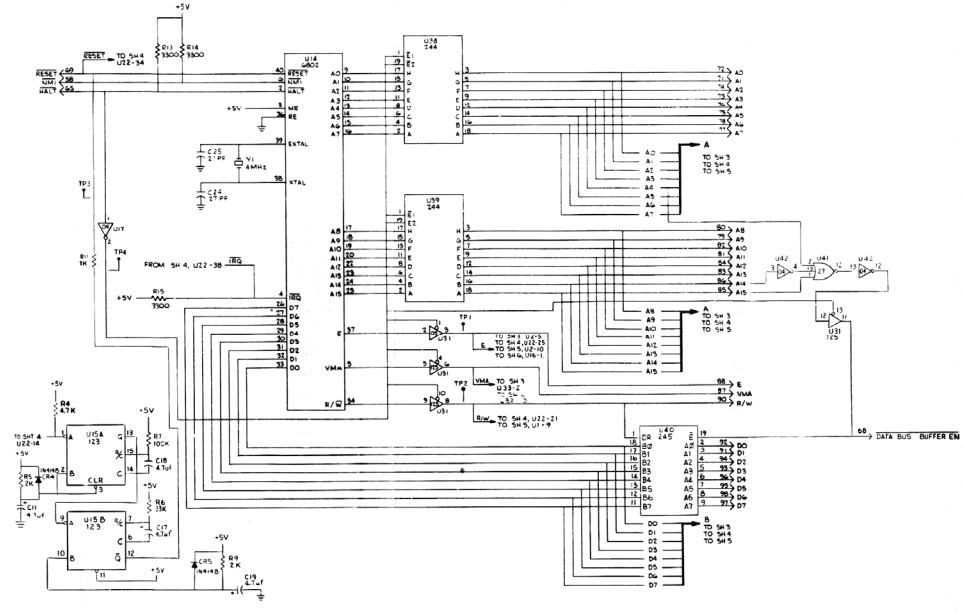

Figure 15-2. Processor Module A9
Schematic Diagram
(Sheet 2 of 7)

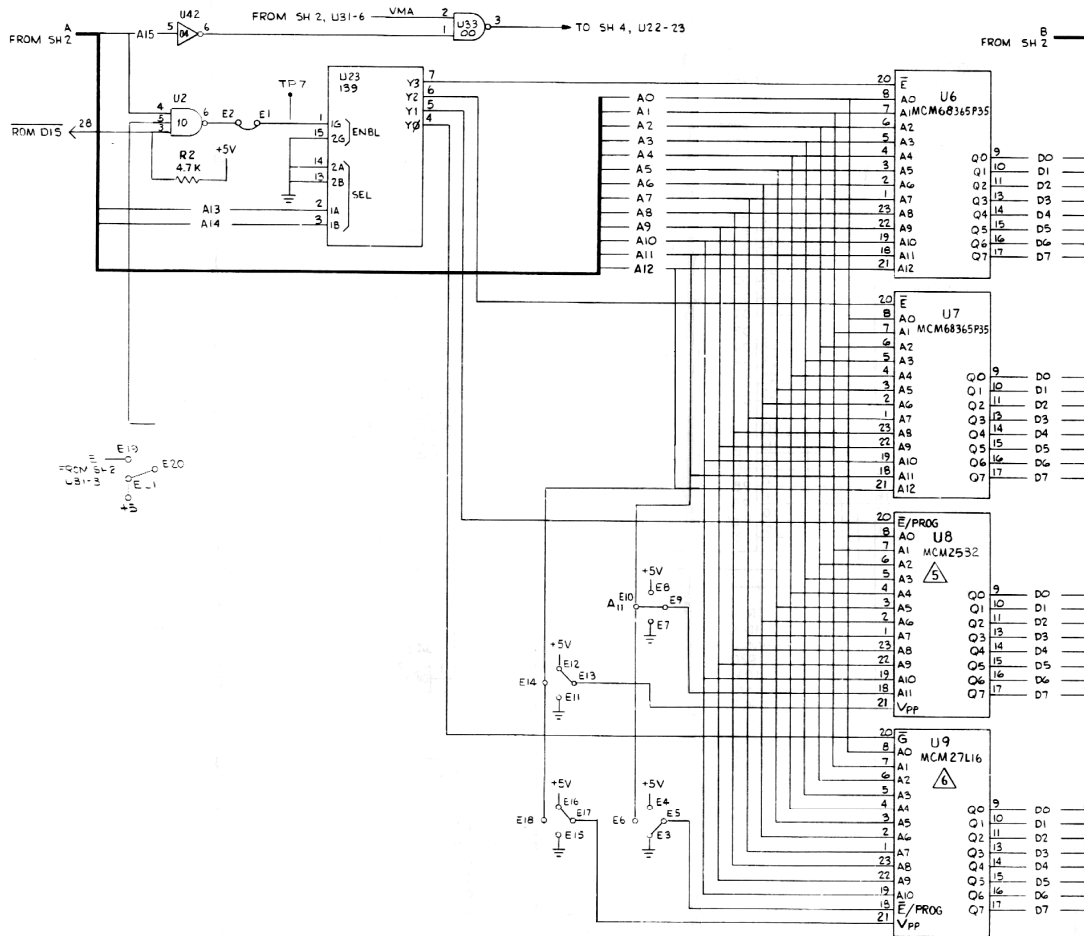

Figure 15-2. Processor Module A9
Schematic Diagram
(Sheet 3 of 7)

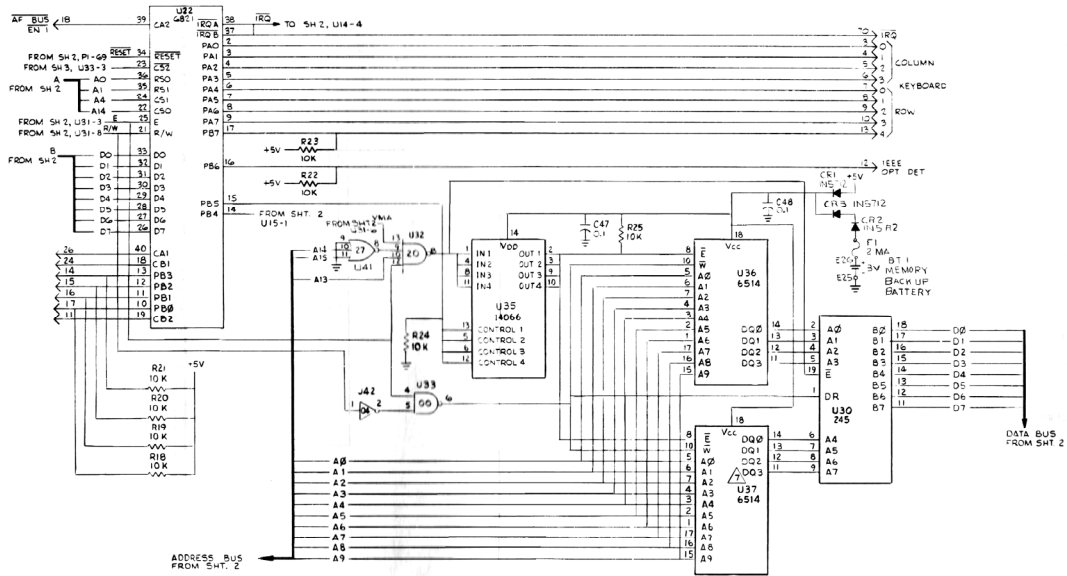

Figure 15-2. Processor Module A9
Schematic Diagram
(Sheet 4 of 7)

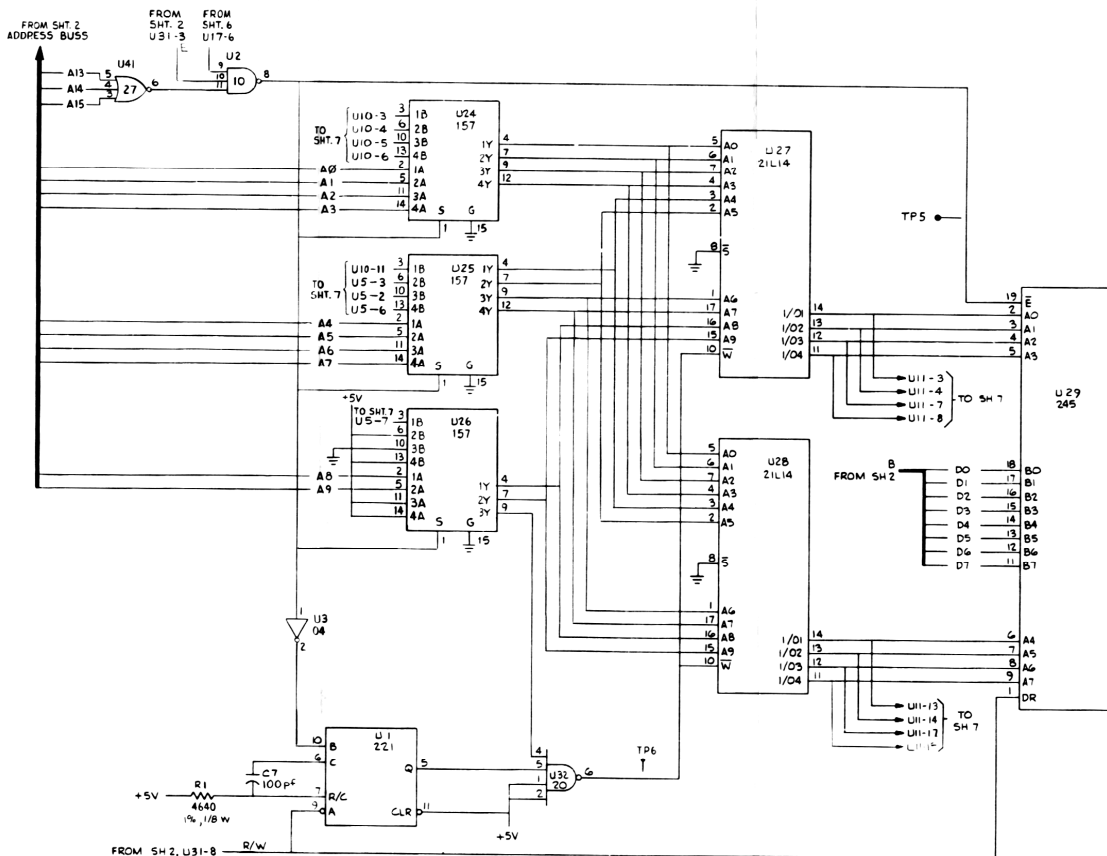

Figure 15-2. Processor Module A9
Schematic Diagram
(Sheet 5 of 7)

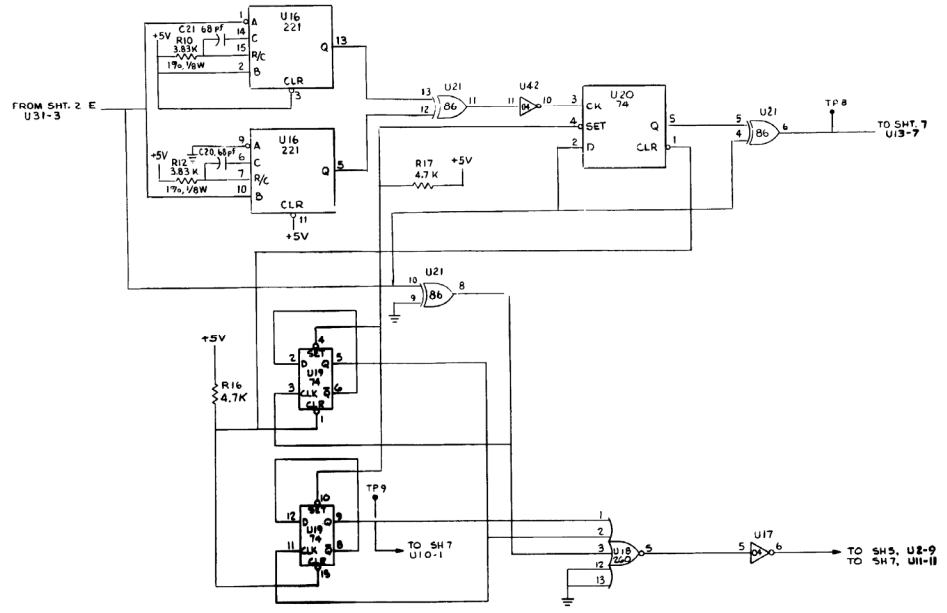

Figure 15-2. Processor Module A9
Schematic Diagram
(Sheet 6 of 7)

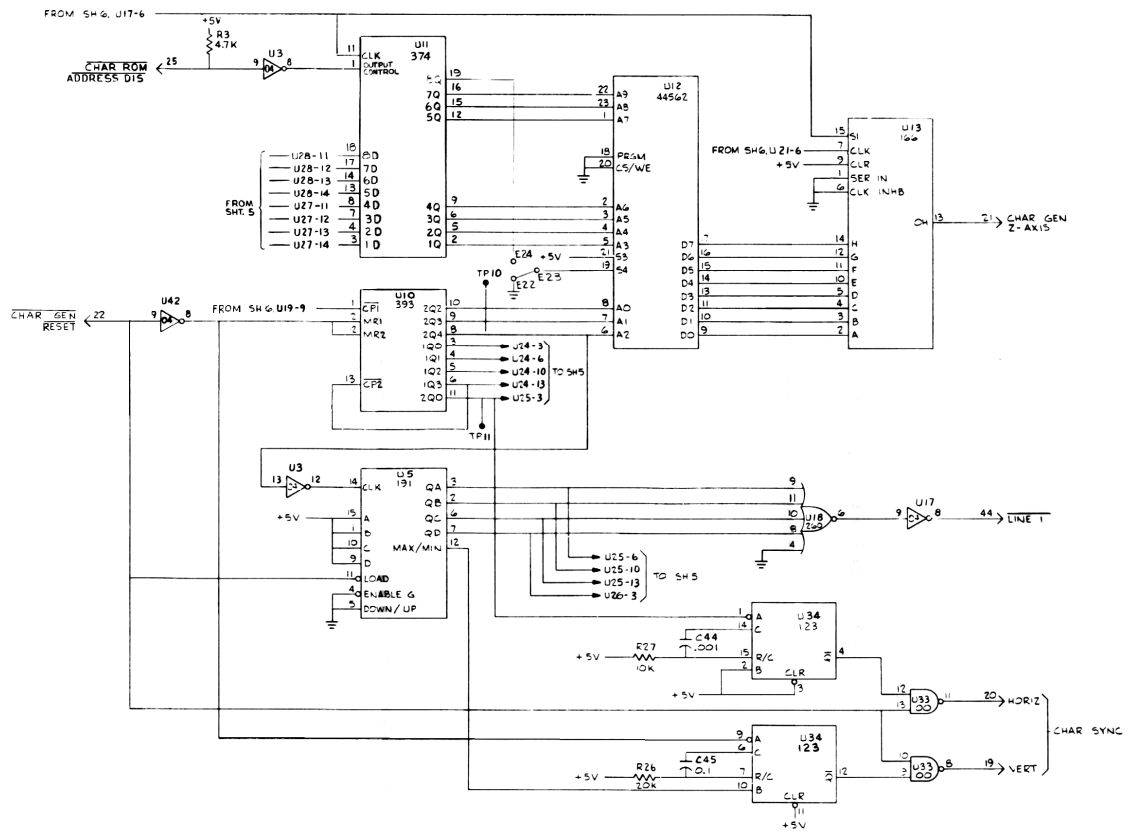

Figure 15-2. Processor Module A9
Schematic Diagram
(Sheet 7 of 7)

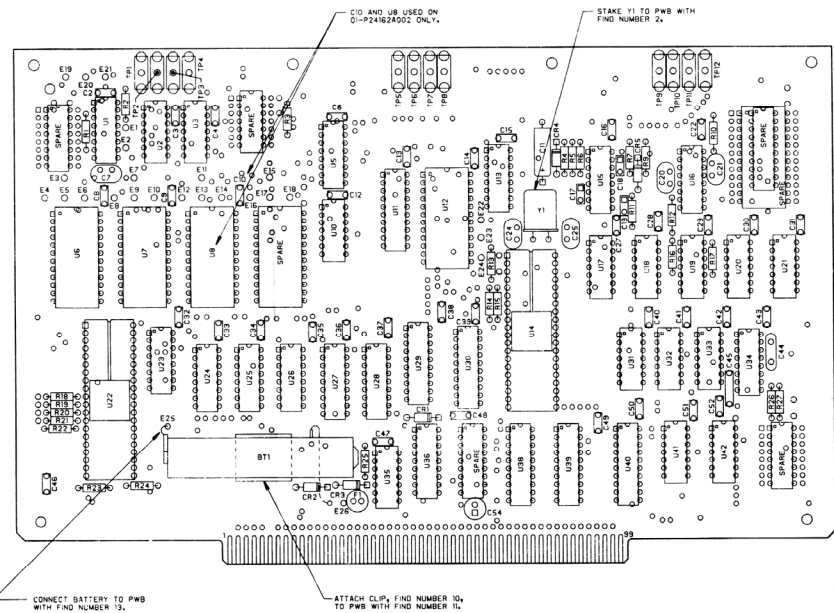

Figure 15-3. Processor Module A9 Parts Location Diagram

Find No.	Qty. Req.	Part No.	Nomenclature	Part Value	Find No.	Qty. Req.	Part No.	Nomenclature	Part Value	Find No.	Qty. Req.	Part No.	Nomenclature	Part Value
001	1	8TC-4026A	MICRO-PRO-7 PWB-DEL		C048	1	21-803694E1	CAPACITOR	1UF-20-100	U002	1	51-803694E5	INTEGRATED CIRCUIT	SATLS250NS SCREEN
002	AR	RTV2145	ADHESIVE SIL RUB		C047	1	21-803694E2	CAPACITOR	1UF-20-100	U003	1	51-803694E1	INTEGRATED CIRCUIT	SATLS250NS SCREEN
003	AR	5865WPS	SOLDER		C046	1	21-803694E2	CAPACITOR	1UF-20-100	U005	1	51-803694E8	INTEGRATED CIRCUIT	SATLS250NS SCREEN
004	AR	11-14187-001	INK	BLACK	C045	1	21-803694E2	CAPACITOR	1UF-20-100	U006	1	51-803694E9	INTEGRATED CIRCUIT	SATLS250NS SCREEN
005	1	07-803384E3	BRACKET/PWB MFG		C049	1	21-803694E2	CAPACITOR	1UF-20-100	U007	1	51-803694E9	INTEGRATED CIRCUIT	SATLS250NS SCREEN
006	4	40241010-0424	PIVET	1.8X 3.12	C051	1	21-803694E2	CAPACITOR	1UF-20-100	U010	1	51-803694E2	INTEGRATED CIRCUIT	SATLS250NS SCREEN
007	2	5C8-000003	EVELET		C052	1	21-803694E2	CAPACITOR	1UF-20-100	U011	1	51-803694E2	INTEGRATED CIRCUIT	SATLS250NS SCREEN
008	2	42CR392001	RETAINER	4.40X 3.12	C054	1	22-903694E2	CAPACITOR	1UF-20-100	U012	1	51-803694E2	INTEGRATED CIRCUIT	SATLS250NS SCREEN
009	2	03-105501	SCREW/PH		C060	1	48-803694E2	DIODE		U013	1	51-803694E2	INTEGRATED CIRCUIT	SATLS250NS SCREEN
011	1	4522 44-50-11	CLIP/COMPONENT		CR002	1	48-803694E2	DIODE		U014	1	51-803694E1	INTEGRATED CIRCUIT	SATLS250NS SCREEN
013	3	493026400 3 4	WIRE/TURN-IND	200X 3.14	CR003	1	48-803694E2	DIODE		U015	1	51-803694E2	INTEGRATED CIRCUIT	SATLS250NS SCREEN
013	AR	424-100T	WIRE BUS		CR004	1	48-803694E2	DIODE		U016	1	51-803694E2	INTEGRATED CIRCUIT	SATLS250NS SCREEN
81001	1	60-803694E1	BATTERY LITHIUM/AA	3V	CR005	1	48-803694E2	DIODE		U017	1	51-803694E1	INTEGRATED CIRCUIT	SATLS250NS SCREEN
C002	1	21-803694E2	CAPACITOR	1UF-20-100	F 001	1	68-803694E2	FUSE	20A	U018	1	51-803694E2	INTEGRATED CIRCUIT	SATLS250NS SCREEN
C003	1	21-803694E2	CAPACITOR	1UF-20-100	R 001	1	06-10021C03	RESISTOR	4665-1.8	U019	1	51-803694E2	INTEGRATED CIRCUIT	SATLS250NS SCREEN
C004	1	21-803694E2	CAPACITOR	1UF-20-100	R 002	1	8912A465	RESISTOR	47K5-1.4	U020	1	51-803694E2	INTEGRATED CIRCUIT	SATLS250NS SCREEN
C006	1	21-803694E2	CAPACITOR	1UF-20-100	R 003	1	8912A465	RESISTOR	47K5-1.4	U021	1	51-803694E2	INTEGRATED CIRCUIT	SATLS250NS SCREEN
C007	1	21-803694E2	CAPACITOR	1000F-5.000	R 004	1	8912A465	RESISTOR	47K5-1.4	U022	1	51-803694E2	INTEGRATED CIRCUIT	SATLS250NS SCREEN
C008	1	21-803694E2	CAPACITOR	1UF-20-100	R 005	1	8912A465	RESISTOR	2K5-1.4	U023	1	51-803694E2	INTEGRATED CIRCUIT	SATLS250NS SCREEN
C009	1	21-803694E2	CAPACITOR	1UF-20-100	R 006	1	8912A465	RESISTOR	39K-5-1.4	U024	1	51-803694E1	INTEGRATED CIRCUIT	SATLS250NS SCREEN
C011	1	20M472018	CAPACITOR	47UF-20-10	R 007	1	8912A469	RESISTOR	100K-5-1.4	U025	1	51-803694E1	INTEGRATED CIRCUIT	SATLS250NS SCREEN
C012	1	21-803694E2	CAPACITOR	1UF-20-100	R 008	1	8912A465	RESISTOR	2K5-1.4	U026	1	51-803694E1	INTEGRATED CIRCUIT	SATLS250NS SCREEN
C013	1	21-803694E2	CAPACITOR	1UF-20-100	R 010	1	06-10021C01	RESISTOR	3820-1.8	U027	1	51-803694E1	INTEGRATED CIRCUIT	SATLS250NS SCREEN
C014	1	21-803694E2	CAPACITOR	1UF-20-100	R 011	1	8912A469	RESISTOR	1K5-1.4	U028	1	51-803694E1	INTEGRATED CIRCUIT	SATLS250NS SCREEN
C015	1	21-803694E2	CAPACITOR	1UF-20-100	R 012	1	06-10021C01	RESISTOR	3000-1.8	U029	1	51-803694E2	INTEGRATED CIRCUIT	SATLS250NS SCREEN
C016	1	21-803694E2	CAPACITOR	1UF-20-100	R 013	1	8912A461	RESISTOR	2.3K-5-1.4	U030	1	51-803694E2	INTEGRATED CIRCUIT	SATLS250NS SCREEN
C017	1	20R841818	CAPACITOR	47UF-20-20	R 014	1	8912A461	RESISTOR	3.3K-5-1.4	U031	1	51-803694E2	INTEGRATED CIRCUIT	SATLS250NS SCREEN
C018	1	20R841818	CAPACITOR	47UF-20-20	R 015	1	8912A461	RESISTOR	3.3K-5-1.4	U032	1	51-803694E2	INTEGRATED CIRCUIT	SATLS250NS SCREEN
C019	1	20R841818	CAPACITOR	47UF-20-20	R 016	1	8912A465	RESISTOR	47K5-1.4	U033	1	51-803694E2	INTEGRATED CIRCUIT	SATLS250NS SCREEN
C020	1	21-803694E2	CAPACITOR	680F-5.000	R 017	1	8912A465	RESISTOR	47K5-1.4	U034	1	51-803694E2	INTEGRATED CIRCUIT	SATLS250NS SCREEN
C021	1	51-802964E7	CAPACITOR	680F-5.000	R 018	1	8912A473	RESISTOR	10K5-1.4	U035	1	51-802964E8	INTEGRATED CIRCUIT	MC4821P SCREENED
C022	1	21-803694E2	CAPACITOR	1UF-20-100	R 019	1	8912A473	RESISTOR	10K5-1.4	U036	1	51-803694E1	INTEGRATED CIRCUIT	CARD RAM
C024	1	21-803694E2	CAPACITOR	2700F-5.000	R 020	1	8912A473	RESISTOR	10K5-1.4	U038	1	51-803694E2	INTEGRATED CIRCUIT	SATLS250NS SCREEN
C025	1	21-803694E2	CAPACITOR	2700F-5.000	R 021	1	8912A473	RESISTOR	10K5-1.4	U039	1	51-803694E2	INTEGRATED CIRCUIT	SATLS250NS SCREEN
C027	1	21-803694E2	CAPACITOR	1UF-20-100	R 022	1	8912A473	RESISTOR	10K5-1.4	U040	1	51-803694E2	INTEGRATED CIRCUIT	SATLS250NS SCREEN
C028	1	21-803694E2	CAPACITOR	1UF-20-100	R 023	1	8912A473	RESISTOR	10K5-1.4	U041	1	51-803694E2	INTEGRATED CIRCUIT	SATLS250NS SCREEN
C029	1	21-803694E2	CAPACITOR	1UF-20-100	R 024	1	8912A473	RESISTOR	10K5-1.4	U042	1	51-803694E1	INTEGRATED CIRCUIT	SATLS250NS SCREEN
C030	1	21-803694E2	CAPACITOR	1UF-20-100	R 025	1	8912A473	RESISTOR	10K5-1.4	Y 001	1	48-803694E8	CRYSTAL	4.0MHz
C031	1	21-803694E2	CAPACITOR	1UF-20-100	R 026	1	8912A480	RESISTOR	20K-5-1.4					
C032	1	21-803694E2	CAPACITOR	1UF-20-100	R 027	1	8912A473	RESISTOR	10K5-1.4					
C033	1	21-803694E2	CAPACITOR	1UF-20-100	TP001	1	00-80331485	JACK T/P	WHY					
C034	1	21-803694E2	CAPACITOR	1UF-20-100	TP002	1	00-80331485	JACK T/P	WHY					
C035	1	21-803694E2	CAPACITOR	1UF-20-100	TP003	1	00-80331485	JACK T/P	WHY					
C036	1	21-803694E2	CAPACITOR	1UF-20-100	TP004	1	00-80331485	JACK T/P	WHY					
C037	1	21-803694E2	CAPACITOR	1UF-20-100	TP005	1	00-80331485	JACK T/P	WHY					
C038	1	21-803694E2	CAPACITOR	1UF-20-100	TP006	1	00-80331485	JACK T/P	WHY					
C039	1	21-803694E2	CAPACITOR	1UF-20-100	TP007	1	00-80331485	JACK T/P	WHY					
C040	1	21-803694E2	CAPACITOR	1UF-20-100	TP008	1	00-80331485	JACK T/P	WHY					
C041	1	21-803694E2	CAPACITOR	1UF-20-100	TP009	1	00-80331485	JACK T/P	WHY					
C042	1	21-803694E2	CAPACITOR	1UF-20-100	TP010	1	00-80331485	JACK T/P	WHY					
C043	1	21-803694E2	CAPACITOR	1UF-20-100	TP011	1	00-80331485	JACK T/P	WHY					
C044	1	21-803694E1	CAPACITOR	10000F-10-100	TP012	1	00-80331483	JACK T/P	WHY					
C045	1	21-803694E5	CAPACITOR	1UF-20-16	U001	1	51-803694E2	INTEGRATED CIRCUIT	SATLS2521N SCREEN					

Figure 15-3. Processor Module A9 (RTC-4026A) Parts Location Diagram (Sheet 2 of 2)

SECTION 16 HIGH VOLTAGE POWER SUPPLY (A10)

16-1. GENERAL. CRT bias and drive voltages are provided by the high voltage power supply. The power supply converts a nominal 15 VDC input to output voltages of +4kV and a -2kV. In addition, control circuits for the CRT focus and intensity grids are contained in this power supply. The high voltage power supply block and schematic diagrams are shown in figures 16-1 and 16-2, respectively.

16-2. HIGH VOLTAGE SUPPLY. An 8 VDC at the center tap of the high voltage transformer is switched, through the transformer primary winding by the chopper, at a 20 kHz rate. The chopper drive signals originate in the low voltage power supply. One transformer secondary winding provides a 6.3 VAC CRT heater voltage. The other transformer secondary winding provides a 1 kV to a X4 multiplier and a X2 multiplier. The output of the X4 multiplier, a nominal +4 kV is the CRT anode voltage. A nominal -2 kV output of the X2 multiplier is applied to the intensity and focus modulators. The -2 kV is regulated by comparing a sample of the -2 kV to a 6.3V reference signal. The resultant signal controls the level of the DC input at the center tap of the high voltage transformer. A bias divider, on the transformer center tap, provides the HV CHOPPER BIAS signal to the low voltage power supply.

16-3. INTENSITY AND FOCUS CONTROL. An 87V zener diode and a resistive divider circuit provide the intensity and focus voltages. Each modulator provides variable output voltages, within their bias range, under the control of the low voltage INTENSITY TV and FOCUS TV input signals. The grid and focus voltages are stabilized by using DC control loops. The INTENSITY SAMPLE signal and the HV REF signal are compared, on the scope amplifier module, to an input control signal. The result of this comparison is the INTENSITY TV signal. In a similar manner, the FOCUS SAMPLE signal is compared, on the scope amplifier module, to the input control signal. This results in the FOCUS TV signal.

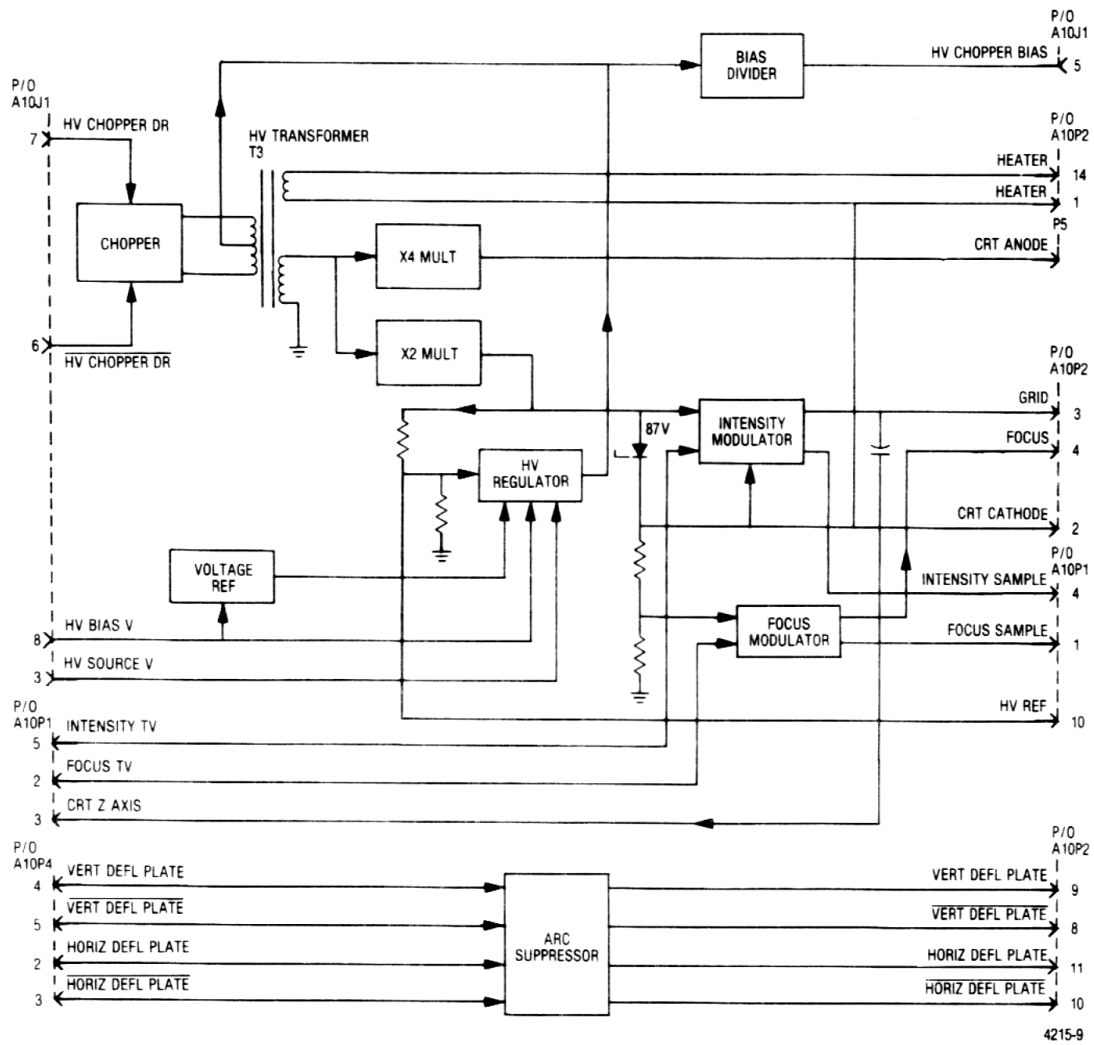

Figure 16-1. High Voltage Power Supply A10 Block Diagram

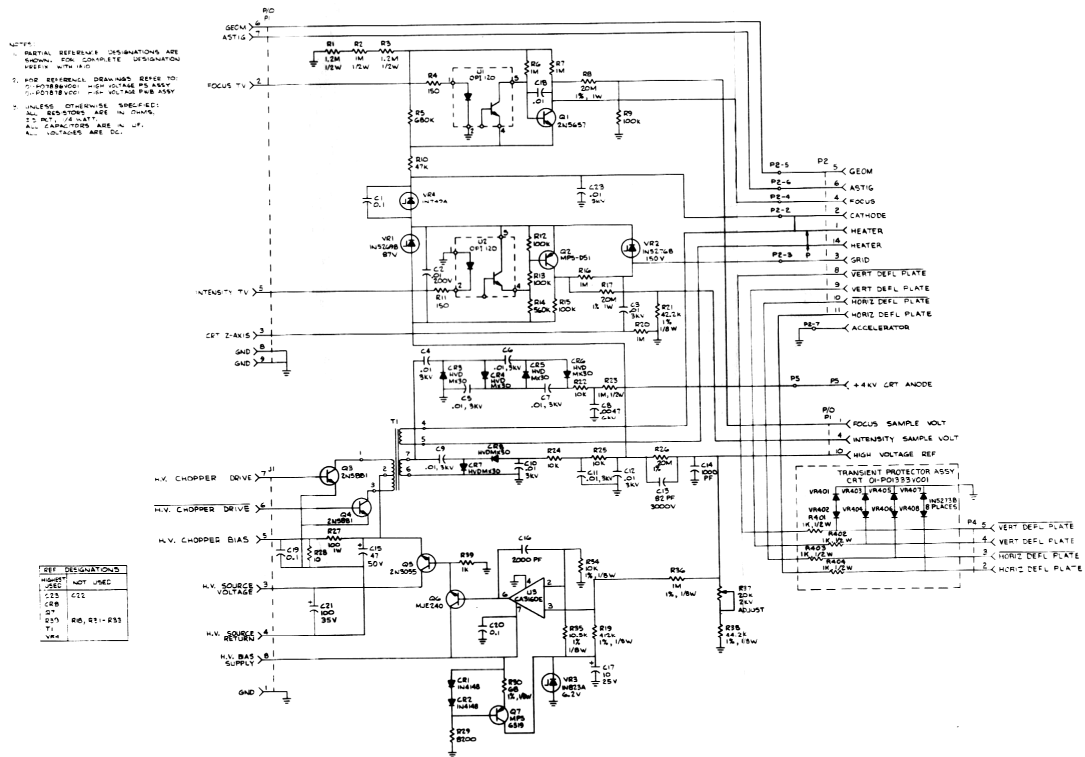

Figure 16-2. High Voltage Power Supply A10 Schematic Diagram

Find No.	Qty. Req.	Part No.	Nomenclature	Part Value
A10		RTP-1006A	HIGH VOLT PWR SUPPLY	
001	1	RTP-4015A	HIGH VOLTAGE PWR B	
002	1	51-98990001	HORIZONTAL PWR BU	
003	2	821-S-2	SCREW CAPTIVE	4.40
004	10	M325206-215	SCREW PH	1190.40X 375
005	10	04-7607	WASHER FLAT	125
006	10	04-114583	WASHER LOCK	112
007	5	3034-3803-14145	WASHER SHOULDER	
008	3	M38278-02P	INSULATOR PLATE P1	103
010	AR	F01A270	WIRE HIGH VOLTAGE	
011	AR		WIRE	
012	AR	SMS5W1MAP3	SOLDER	#24 WHY
013	AR	11-14187A01	INK	BLACK
014	1	01-8006460	TRANSIENT PROTECTO	
015	1	M323488-6	GROMMET	
016	1	11-80073447	INSULATOR	
017	1	3016-A-3-A-9	SPACER	
018	AR	M32987-4-9	STRAP THERDOWN	
019	AR	M320519-103-C	INSULATOR GLEWIN	093 CLR
020	1	33-14232A09	PLATE IDENT HV-V	
021	AR	495-04	ADHESIVE TAPE CLURE	
022	AR		TAPE THIN 00041	
P002	1	06-80311A02	CONNECTOR CRT	2.3 X 176 400
Q003	1	46-80084A05	TRANSISTOR	
Q004	1	46-80084A05	TRANSISTOR	
Q005	1	46-8889302	TRANSISTOR	

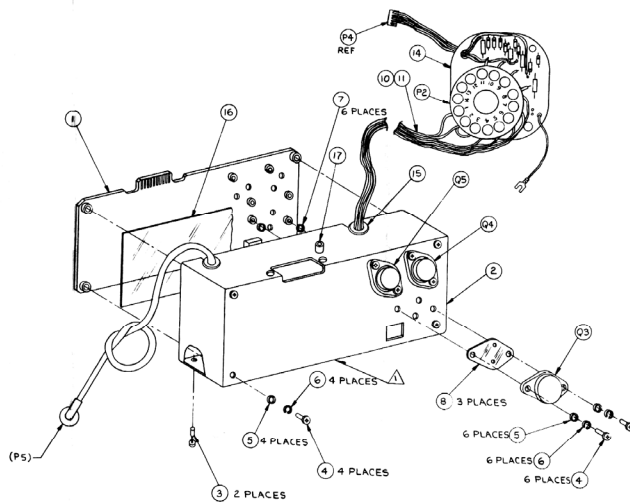
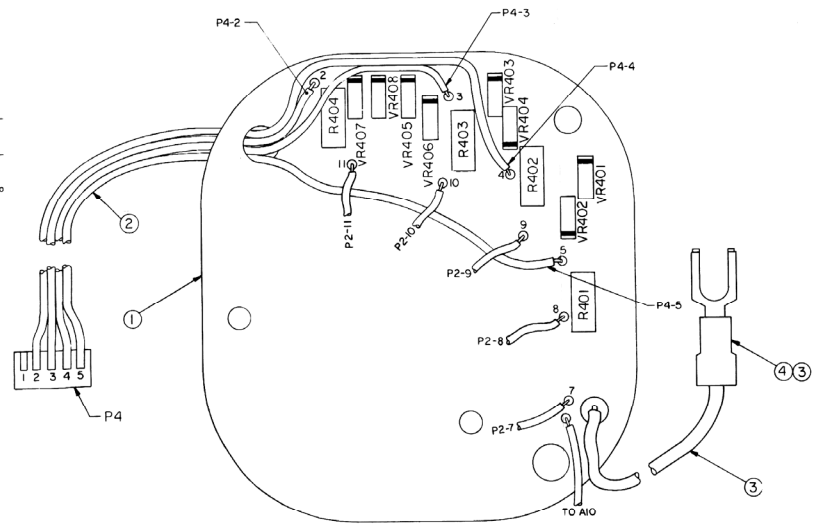

Figure 16-3. High Voltage Power Supply A10 (RTP-1006A) Parts Location Diagram

Part No.	Qty.	Part No.	Nomenclature	Part Value
001	1	84-PC1332V001	PRINTED WIRING BOA	TRANSIENT PROTECTOR
002	AR		WIRE	#18 WHIT
003	AR		WIRE	#18 WHIT
004	1	6015L	TERMINAL LUG	
005	AR	5042309F2	SOLDER	
006	AR	MS3307-4-8	STRAP/TIEDOWN	
P 004	1	603445-5	CONNECTOR 5 PIN	
R 401	1	06-125A49	RESISTOR	1000Ω-5-1/2
R 402	1	06-125A49	RESISTOR	1000Ω-5-1/2
R 403	1	06-125A49	RESISTOR	1000Ω-5-1/2
R 404	1	06-125A49	RESISTOR	1000Ω-5-1/2
VR401	1	48-80268A05	DIODE ZENER	120V
VR402	1	48-80268A05	DIODE ZENER	120V
VR403	1	48-80268A05	DIODE ZENER	120V
VR404	1	48-80268A05	DIODE ZENER	120V
VR405	1	48-80268A05	DIODE ZENER	120V
VR406	1	48-80268A05	DIODE ZENER	120V
VR407	1	48-80268A05	DIODE ZENER	120V



1-80304A60

Figure 16-4. Communications System Analyzer Transient Protector Assembly Parts Location Diagram

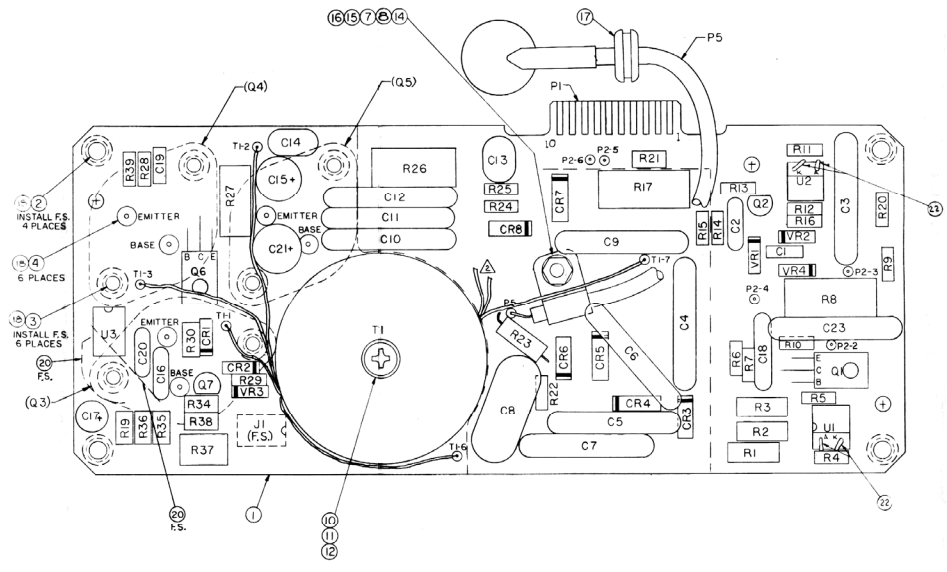

RTP-4015A

Figure 16-5. High Voltage Power Supply A10 PWB Parts Location Diagram (Sheet 1 of 2)

Find No.	Qty. Req.	Part No.	Nomenclature	Part Value
		RTP-4015A	HIGH VOLT PWR SUP	
001	1	84-P07879V001	PRINTED WIRING BOA	
002	4	B1534-B-1 8-5	SPACER SWAGE	125LG
003	6	B1534-B-3 32-5	SPACER SWAGE	093LG
004	6	640206-1	JACK PRINTED CIRCU	
007	1	M535206-217	SCREW PH	1120-40X 500
008	1	Q2-7019	NUT	1120-40
010	1	M535206-329	SCREW	1380-32X1 375
011	1	M527183-5	WASHER FL	158
012	1	KF2-632	NUT CLINCH	6-32
014	1	42-15031A60	CLAMP LOOP NYLON	
015	1	04-7607	WASHER FLAT	125
016	1	04-114583	WASHER LOCK	112
017	1	M535489-4	GROMMET RUBBER	
018	AR	SN63WRP3	SOLDER	
019	AR	11-14167A01	INK	BLACK
020	AR		WIRE BOLD	#26 WHT
021	AR	RTV3140	COATING SILICONE	
022	AR		INSULATION SLEEVE	#24 WHT
C 001	1	21-80369A82	CAPACITOR	1UF 20 100
C 002	1	21-80396A52	CAPACITOR	01UF 20 + 80-200
C 003	1	21D83596E19	CAPACITOR	01UF + 80-20-3KV
C 004	1	21D83596E19	CAPACITOR	01UF + 80-20-3KV
C 005	1	21D83596E19	CAPACITOR	01UF + 80-20-3KV
C 006	1	21D83596E19	CAPACITOR	01UF + 80-20-3KV
C 007	1	21D83596E19	CAPACITOR	01UF + 80-20-3KV
C 008	1	21-80369A80	CAPACITOR	0047 6000
C 009	1	21D83596E19	CAPACITOR	01UF + 80-20-3KV
C 010	1	21D83596E19	CAPACITOR	01UF + 80-20-3KV
C 011	1	21D83596E19	CAPACITOR	01UF + 80-20-3KV
C 012	1	21D83596E19	CAPACITOR	01UF + 80-20-3KV
C 013	1	21-80370A30	CAPACITOR	82PF 3KV
C 014	1	21-80396A51	CAPACITOR	1000PF 10 100
C 015	1	23-80369A79	CAPACITOR	47UF 50V
C 016	1	21D82428B36	CAPACITOR	2000PF 10 200
C 017	1	23-80396A40	CAPACITOR	10UF 25V
C 018	1	21D82428B19	CAPACITOR	01UF 20 500
C 019	1	21-80369A82	CAPACITOR	1UF 20 100
C 020	1	21-80369A82	CAPACITOR	1UF 20 100
C 021	1	23-80369A73	CAPACITOR	100UF 35V
C 023	1	21D83596E19	CAPACITOR	01MF 3KV
CR001	1	48-84463K02	DIODE	
CR002	1	48-84463K02	DIODE	
CR003	1	48-80345A63	DIODE	
CR004	1	48-80345A63	DIODE	
CR005	1	48-80345A63	DIODE	
CR006	1	48-80345A63	DIODE	
CR007	1	48-80345A63	DIODE	
CR008	1	48-80345A63	DIODE	
J 001	1	09-80331A95	SOCKET SOLDER DIP	8 PIN
P 005	1	01-80350A53	LEAD ASSEMBLY HV	
Q 001	1	48-80341A45	TRANSISTOR	
Q 002	1	48-80341A46	TRANSISTOR	MPS-D51 SCREENED
Q 006	1	48-80368A87	TRANSISTOR	

Find No.	Qty. Req.	Part No.	Nomenclature	Part Value
Q 007	1	48-80368A92	TRANSISTOR	MPS6519 SCREENED
R 001	1	6S125B24	RESISTOR	1.2M-5-1/2
R 002	1	6S125B22	RESISTOR	1M-5-1/2
R 003	1	6S125B24	RESISTOR	1.2M-5-1/2
R 004	1	6S124A29	RESISTOR	150-5-1/4
R 005	1	6S124B18	RESISTOR	680K-5-1/4
R 006	1	6S124B22	RESISTOR	1M-5-1/4
R 007	1	6S124B20	RESISTOR	1M-5-1/4
R 008	1	6-80331A37	RESISTOR	20M-1-1
R 009	1	6S124A97	RESISTOR	100K-5-1/4
R 010	1	6S124A89	RESISTOR	47K-5-1/4
R 011	1	6S124A29	RESISTOR	150-5-1/4
R 012	1	6S124A87	RESISTOR	100K-5-1/4
R 013	1	6S124A97	RESISTOR	100K-5-1/4
R 014	1	6S124B16	RESISTOR	560K-5-1/4
R 015	1	6S124A97	RESISTOR	100K-5-1/4
R 016	1	6S124B22	RESISTOR	1M-5-1/4
R 017	1	6-80331A37	RESISTOR	20M-1-1
R 019	1	06-10821E48	RESISTOR	419K-1-1/8
R 020	1	6S124B22	RESISTOR	1M-5-1/4
R 021	1	06-10821C52	RESISTOR	42.2K-1-1/8
R 022	1	6S124A75	RESISTOR	10K-5-1/4
R 023	1	6S125B20	RESISTOR	1M-5-1/2
R 024	1	6S124A75	RESISTOR	10K-5-1/4
R 025	1	6S124A75	RESISTOR	10K-5-1/4
R 026	1	6-80331A37	RESISTOR	20M-1-1
R 027	1	6S126A25	RESISTOR	100-5-1
R 028	1	6S124A01	RESISTOR	10-5-1/4
R 029	1	6S124A71	RESISTOR	8.2K-5-1/4
R 030	1	06-10821A81	RESISTOR	68.1-1-1/8
R 034	1	06-10821C91	RESISTOR	10K-1-1/8
R 035	1	06-10821C93	RESISTOR	10.5K-1-1/8
R 036	1	06-10821E85	RESISTOR	1M-1-1/8
R 037	1	18D83452F33	RESISTOR VARIABLE	20K
R 038	1	06-10821C54	RESISTOR	44.2K-1-1/8
R 039	1	6S124A46	RESISTOR	1K-5-1/4
T 001	1	25-80369A13	TRANSFORMER	
U 001	1	51-P07838V002	INTEGRATED CIRCUIT	OP120 SCREENED
U 002	1	51-P07838V002	INTEGRATED CIRCUIT	OP120 SCREENED
U 003	1	51-80345A02	INTEGRATED CIRCUIT	CA3160E SCREENED
VR001	1	48-80345A86	DIODE ZENER	87V-5-5
VR002	1	48-80345A87	DIODE ZENER	150V-5-5
VR003	1	48-80368A98	DIODE ZENER	6.2V-5-4
VR004	1	48-83461E13	DIODE ZENER	

RTP-4015 A

Figure 16-5. High Voltage Power Supply
A10 PWB Parts Location
Diagram (Sheet 2 of 2)

SECTION 17

RF INPUT MODULE (A11)

17-1. General. The RF Input Module is subdivided into three isolated circuits: input protection and power meter, wideband amplifier and frequency converter, and duplex generator. A block diagram of the RF Input Module is shown in figure 17-1 with its schematic shown in figure 17-2.

17-2. Input Protection and Power Meter. RF power to and from the system pass through this section to a common input/output RF connector (RF In/Out) attached to the module. In the generate or monitor operating modes the input protection relay is switched so that a low-loss 50-ohm path exists through the module. When the power monitor mode is selected, the WATT MTR EN line switches the relay so that the input is connected to a 50 ohm power termination. A detector across a portion of the load provides a DC level proportional to the input RF level. This level is amplified and made available to the system processor for the determination of input power. A terminal sensor monitors the load temperature and signals the processor when safe operating limits are exceeded. The processor in turn warns the operator that the RF input to the unit must be removed to prevent permanent damage.

17-3. If power in excess of 200 mW is applied to the system while operating in either the generate or monitor mode, the input is automatically switched to the 50 ohm load termination to protect the system. A signal line (INPUT PROTECT ACT) to the processor results in an audible and visual warning to the operator that the unit is in a protected mode. The warning ceases and normal operation resumes if the RF input is removed or if the power monitor mode is selected.

17-4. Wideband Amplifier and Frequency Converter. The wideband amplifier provides a leveled RF output from -3 dBm to $+13$ dBm in the generate mode and a $+7$ dBm LO drive in the monitor modes over the 10 KHz to 1 GHz frequency range. Primary components of the leveling loop are; the input VCA (Voltage Controlled Attenuator), the output level detector, and the level comparator. A level control voltage, proportional to the desired output level is compared to the actual output level as determined by the level detector. The result of the comparison steers the VCA maintaining the detected output level equal to the requested output level. In the generate mode the control voltage is obtained from the front panel RF level control (AM Mod + DC REF). For generate AM, the modulation signal is summed with the DC control level, causing the RF output level to follow the modulation signal. Also, in the generate mode the signal from the output level detector (CARRIER + MOD LVL) is made available for the determination of RF output power and percent of AM. A fixed reference voltage is switched to the level control input in the monitor modes giving a leveled $+7$ dBm local oscillator drive.

17-5. The VCA on the wideband amplifier board covers the frequency range from 1 MHz to 1 GHz. For frequencies below 1 MHz, the VCA select circuit clamps the VCA in the minimum position and enables a low frequency VCA in the RF Synthesizer. Coincident with the enabling of the low frequency VCA, the time constant of the output RF level detector is increased assuring proper operation down to 10 kHz.

17-6. The wideband amplifier output is relay switched between the local oscillator port of the input mixer for the monitor and generate DSBSC modes, and the RF attenuator for the generate mode. An RF sample from the mixer local oscillator output terminal, at a nominal level of -20 dBm, is provided to the duplex generator.

17-7. The frequency converter section consists of the input mixer, the first IF amplifier, and IF filters. In the monitor mode the desired signal is converted to 10.7 MHz by the input mixer. A two-pole input filter, IF amplifier, and a four-pole output filter select the 10.7 MHz component at the mixer output. The 10.7 MHz IF output of the converter is applied to the receive module.

17-8. For DSBSC generator the modulation audio is applied to the IF port of the input mixer through an isolation network. With the output of the wideband amplifier switched to the local oscillator port, a DSBSC signal is present at the RF port. Switching the Step Attenuator to the RF output port makes the DSBSC signal available at the RF output.

17.9. Duplex Generator. The Duplex Generator output is a frequency component that is offset from the system monitor frequency by 0 to 10 MHz or by 45 MHz. The offset is obtained by mixing the -20 dBm local oscillator signal from the wideband amp, which is already offset by 10.7 MHz, with a signal frequency from 10.7 MHz to 0.7 MHz or 34.3 MHz.

17-10. For the 3433MHz mixing signal, a single VCO is used. Tuning of the VCO is with the OFFSET FINE TUNE line from the front panel. Frequency modulation of the VCO is implemented by summing the OFFSET MOD signal with the tuning voltage.

17-11. For the 0.7 MHz to 10.7 MHz mixing signal a VCO with a frequency range from 35 MHz to 45 MHz is mixed with the 34.3 MHz VCO. The 35-45 MHz VCO is tuned by the OFFSET COARSE TUNE line from the front panel.

17-12. A sample of the offset frequency is made available to the frequency counter on the OFFSET FREQ line. The processor uses the frequency information to calculate and display the actual duplex frequency

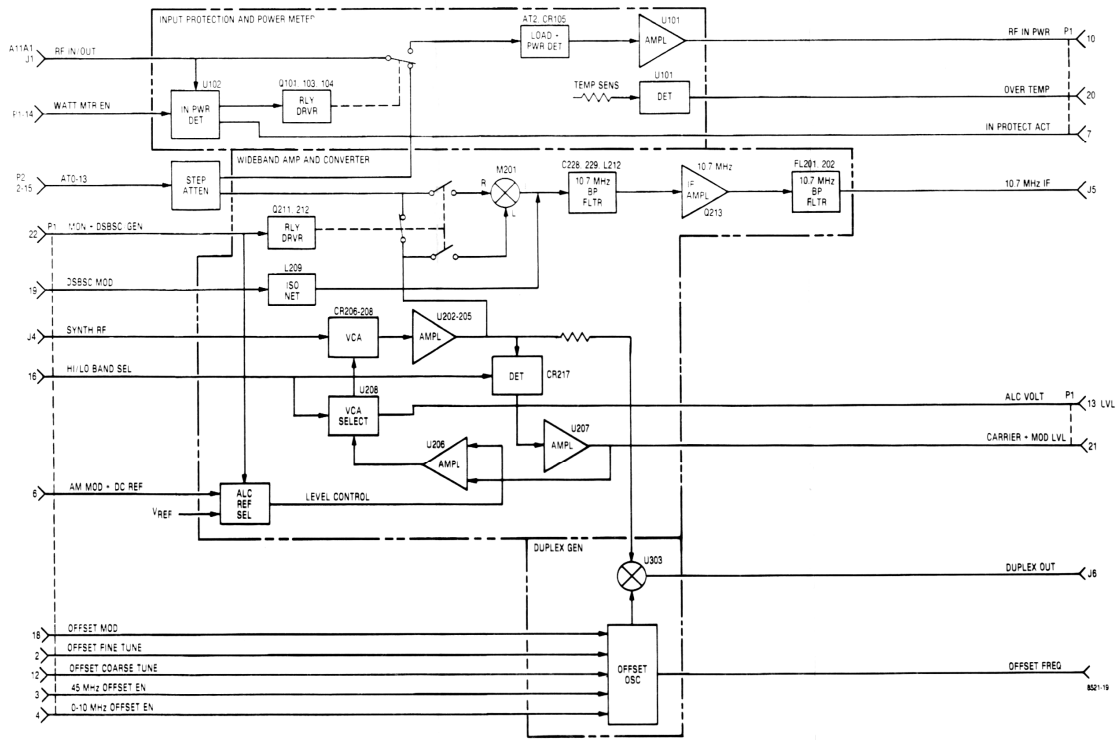

Figure 17-1. RF Input Module A11 Block Diagram

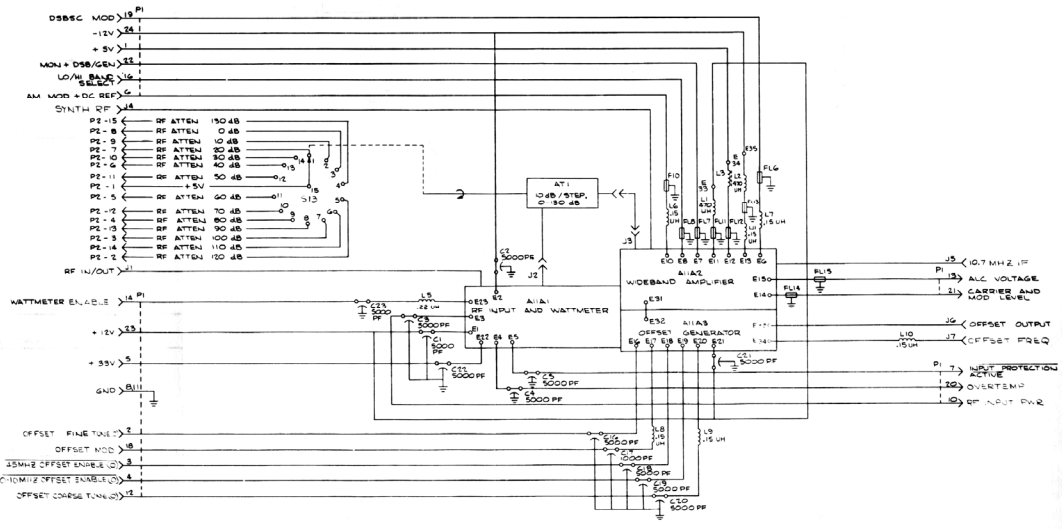

Figure 17-2. RF Input Module A11 Schematic Diagram

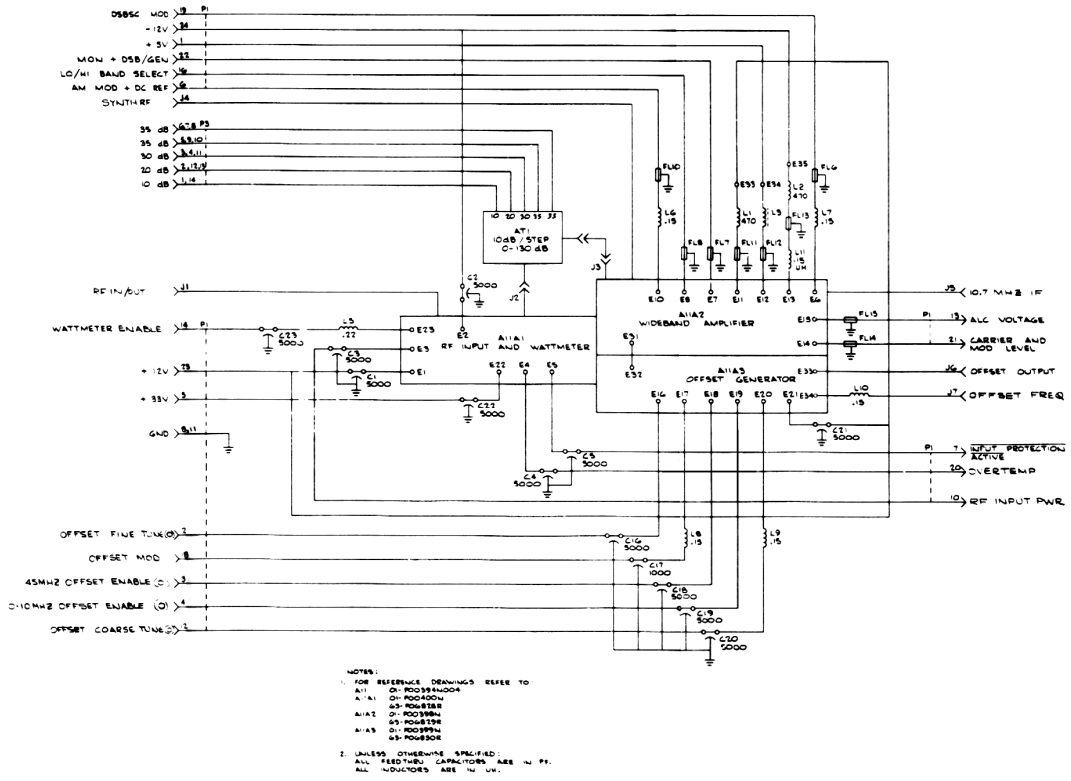
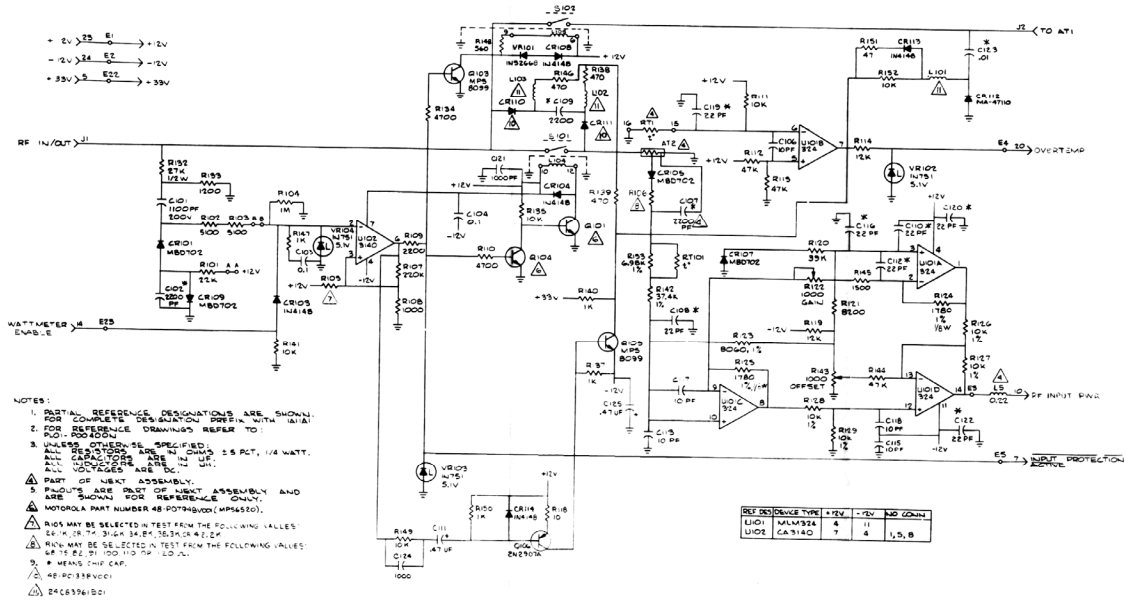

Figure 17-3. RF Input Module A11 with IEEE Option Schematic Diagram



- NOTES:
1. PARTIAL REFERENCE DESIGNATIONS ARE SHOWN FOR COMPLETE DESIGNATION REFER TO: FIG. 17-5A
 2. FOR REFERENCE DRAWINGS REFER TO: FIG. 17-5A
 3. UNLESS OTHERWISE SPECIFIED ALL RESISTORS ARE IN OHMS ± 5 PCT. 1/4 WATT. ALL CAPACITORS ARE IN UF. ALL WORKS ARE 5C.
- ▲ PART OF NEXT ASSEMBLY.
- ▲ PARTS ARE FROM THE LIGHT ASSEMBLY AND ARE SHOWN FOR REFERENCE ONLY.
- ▲ MOTOROLA PART NUMBER 48 POT98V00 (MPS650).
- ▲ R101 MAY BE SELECTED IN TEST FROM THE FOLLOWING VALUES: 5K, 10K, 15K, 20K, 25K, 30K, 35K, 40K, 45K.
- ▲ R102 MAY BE SELECTED IN TEST FROM THE FOLLOWING VALUES: 5K, 10K, 15K, 20K, 25K, 30K, 35K, 40K, 45K.
- ▲ R103, R104, R105, R106, R107, R108, R109, R110, R111, R112, R113, R114, R115, R116, R117, R118, R119, R120, R121, R122, R123, R124, R125, R126, R127, R128, R129, R130, R131, R132, R133, R134, R135, R136, R137, R138, R139, R140, R141, R142, R143, R144, R145, R146, R147, R148, R149, R150, R151, R152, R153, R154, R155, R156, R157, R158, R159, R160, R161, R162, R163, R164, R165, R166, R167, R168, R169, R170, R171, R172, R173, R174, R175, R176, R177, R178, R179, R180, R181, R182, R183, R184, R185, R186, R187, R188, R189, R190, R191, R192, R193, R194, R195, R196, R197, R198, R199, R200.
- ▲ R101, R102, R103, R104, R105, R106, R107, R108, R109, R110, R111, R112, R113, R114, R115, R116, R117, R118, R119, R120, R121, R122, R123, R124, R125, R126, R127, R128, R129, R130, R131, R132, R133, R134, R135, R136, R137, R138, R139, R140, R141, R142, R143, R144, R145, R146, R147, R148, R149, R150, R151, R152, R153, R154, R155, R156, R157, R158, R159, R160, R161, R162, R163, R164, R165, R166, R167, R168, R169, R170, R171, R172, R173, R174, R175, R176, R177, R178, R179, R180, R181, R182, R183, R184, R185, R186, R187, R188, R189, R190, R191, R192, R193, R194, R195, R196, R197, R198, R199, R200.

Figure 17-5. RF Input/Wattmeter PWB A11A1 Schematic Diagram

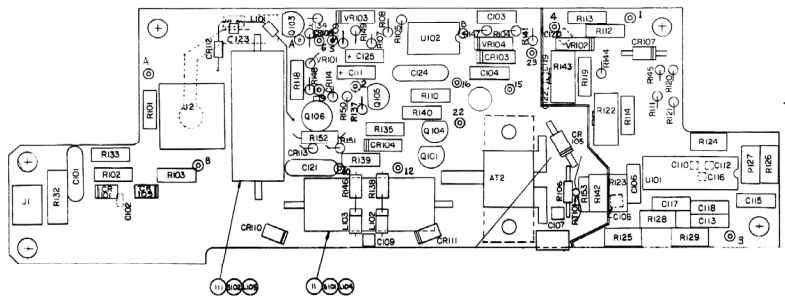

Figure 17-6. RF Input/Wattmeter A11A1 (RTL-4081B) Parts Location Diagram (Sheet 1 of 2)

SECTION 18

FRONT PANEL INTERFACE MODULE (A12)

18-1. GENERAL. The front panel interface module contains the input buffers for front panel control to the processor. In addition, buffering and ranging circuits for external scope vertical/horizontal, SINAD, DVM, and frequency counter inputs are in this module. A block diagram and schematic diagram of the Front Panel Interface Module is shown in figures 18-1 and 18-2, respectively.

18-2. Input Coupling and Ranging. Scope inputs to the Range Attenuator are from the front panel jack (EXT IN) or from the internal modulation sources (INT SCOPE TO RING SW). An INT/EXT relay selects the input path. The external path may be AC or DC coupled and is also the path for external DVM, Frequency Counter, and SINAD inputs.

18-3. Four decades of attenuation from 1.0 to 0.001 are provided by the Range Attenuator. The input impedance of the attenuator is 1.0 megohm compensated for a bandwidth of 1 MHz. A unity gain buffer amp following the attenuator provides the drive for the DVM, Frequency Counter, and scope Vertical Preamp circuits.

18-4. DVM Buffer. For DC measurements the DVM Buffer provides a 2-pole low pass filter with a minimum of 30 dB attenuation at 50 Hz. For AC measurements the bandwidth of the buffer is switched so that the attenuation at 10 kHz is less than 0.5 dB.

18-5. Frequency Counter Preamp. The frequency Counter Preamp has sufficient gain for 30 mV rms sensitivity and provides hysteresis for noise immunity.

18-6. Scope Vertical Preamp. A calibrated gain of 50 or a variable gain from 5 to 50 is provided by the Vertical Preamp. The gain is controlled from the front panel. From vertical scope positioning the DC bias point of the preamp is controlled by the front panel position control. Deflection sensitivity at the VERT FROM RING SW output is 0.5 volt per division.

18-7. Scope Horizontal Preamp. A fixed gain of 5 in the Horizontal Preamp gives a horizontal input sensitivity of 0.1 volt per division. Horizontal vernier gain is implemented on the front panel, and horizontal positioning on the Scope Amplifier module. Deflection sensitivity at the HORIZ TO SCOPE AMPL is 0.5 volt per division

18-8. Control and Display Interface. Front panel control information is input to the processor in 4-bit groups through the AF control bus. Priority encoders convert the multiposition switch positions (scope horizontal, frequency scan, and RF step attenuator) to 4-bit codes. The processor sequentially addresses each input buffer (AF ADRS BUS 0-3) through the Address Decoder. Data in the selected buffer is then transferred to the processor on the AF DATA BUS 0-3 lines while the AF BUS EN 2 signal is low. Two additional latches provide the processor control interface for the Range Attenuator, input switching, and DVM Buffer control.

18-9. AF BUS. The AF Bus consists of a 4-bit tri-state bus data AF DATA BUS 0-3 and a 4-bit address bus AF ADD BUS 0-3. Individual input/output bus locations are addressed by AF ADD BUS 0-3. When AF BUS EN 2 is low, the function of the AF DATA BUS lines are determined by the address present on the AF ADD BUS lines

18-10. LED CONTROL. Control output to the display, function, and modulation mode LEDs is by the AF BUS addressed 0, 1, and 2, respectively. Latch select outputs LS0, LS1, and LS2 are low to latch data present on the AF DATA BUS when the corresponding address is enabled on the AF ADD BUS. These latch select outputs and the AF DATA BUS are connected to the LED display board A14A1.

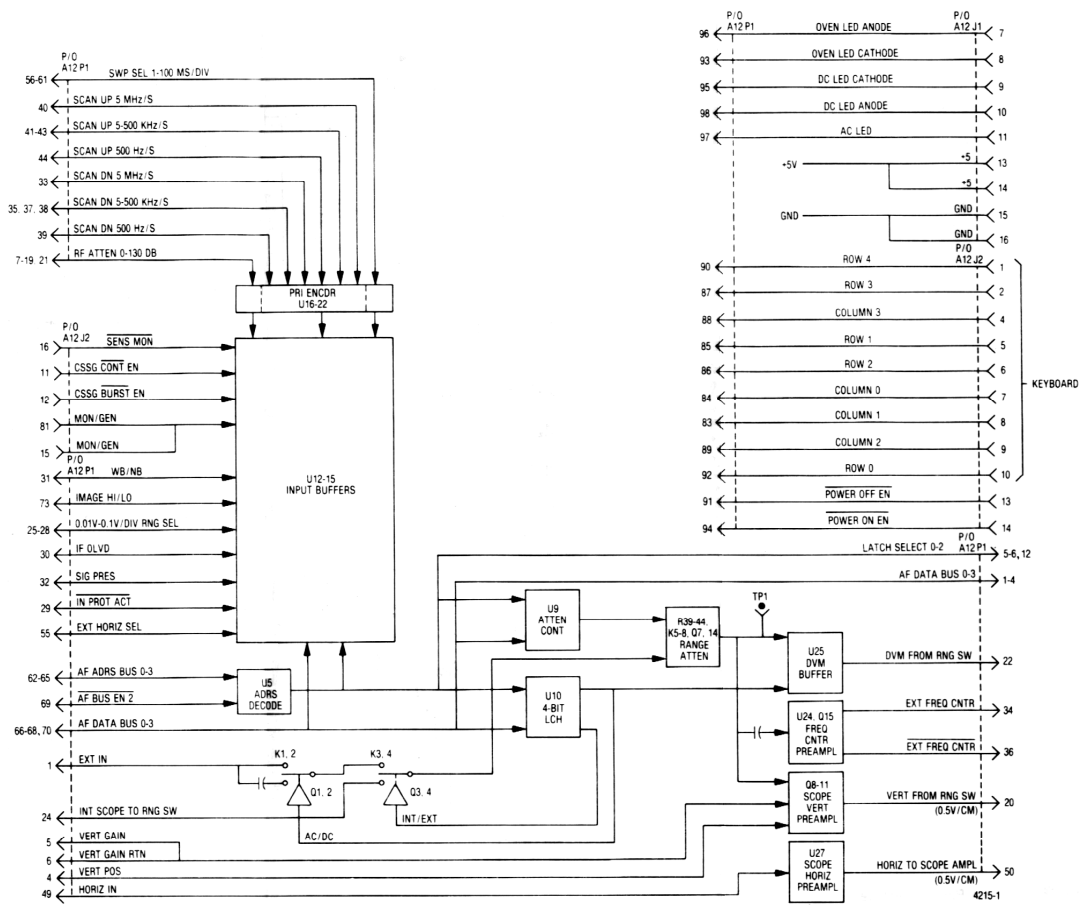

Figure 18-1. Front Panel Interface Module A12 Block Diagram

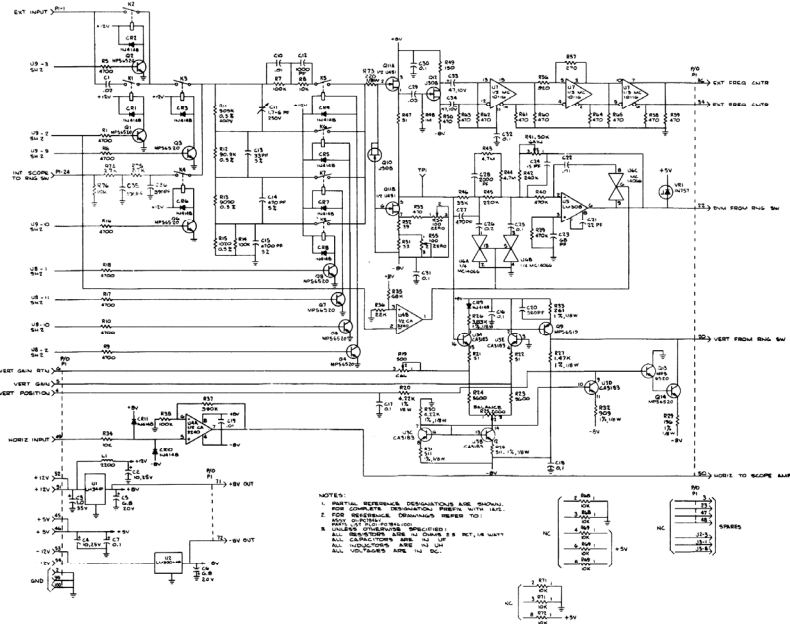

Figure 18-2. Front Panel Interface
Module A12 Schematic
Diagram (Sheet 1 of 2)

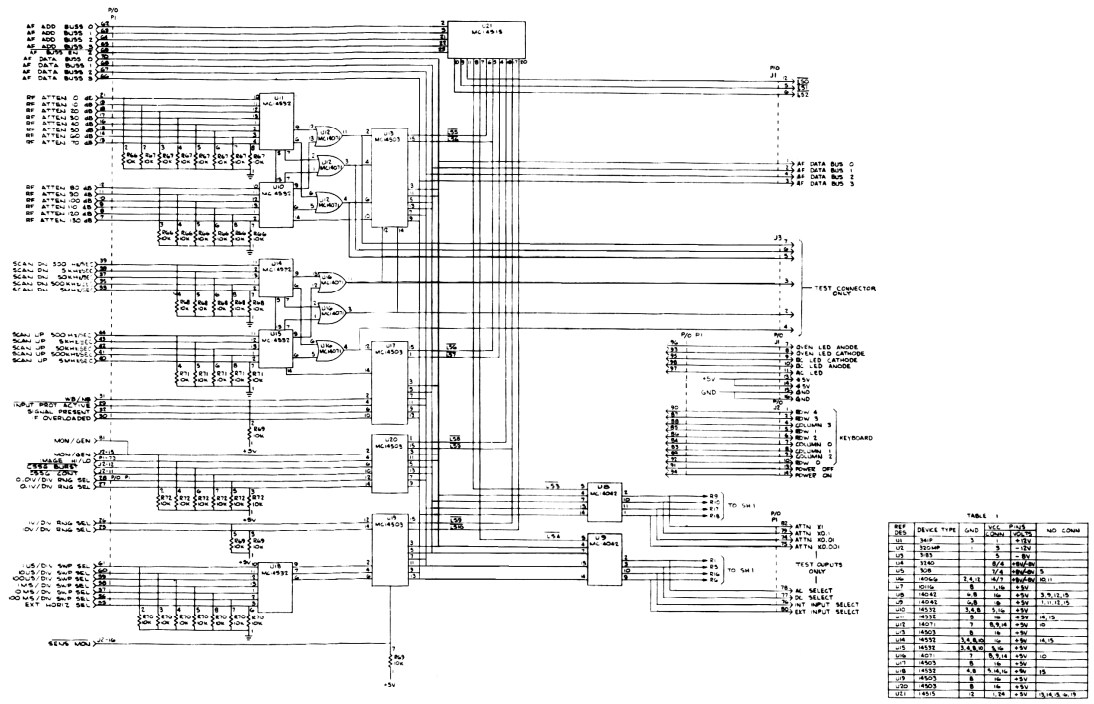

Figure 18-2. Front Panel Interface
Module A12 Schematic
Diagram (Sheet 2 of 2)

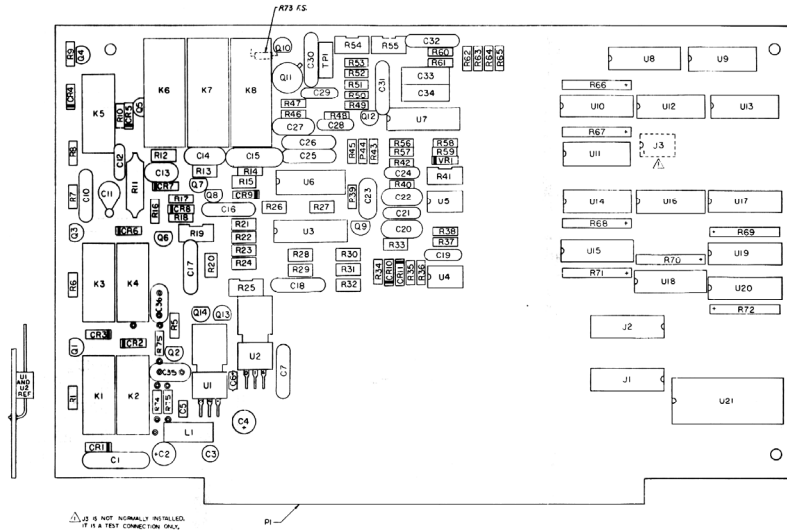

Figure 18-3. Front Panel Interface Module A12 (RTL-4086A) Parts Location Diagram (Sheet 1 of 2)

Find No.	Qty Req.	Part No.	Nomenclature	Part Value	Find No.	Qty Req.	Part No.	Nomenclature	Part Value	Find No.	Qty Req.	Part No.	Nomenclature	Part Value
		RTL 4086A	F FRONT INTERFACE											
001	1	84 803781001	PWB FRONT PANEL 1		001	1	24 80369113	COL	2200P	004	1	6512449	RESISTOR	100 5-1.4
003	AR	5M63VMMAP3	SOLDER		002	1	48 80368111	TRANSISTOR	MP5820 SCREENED	006	1	6512441	RESISTOR	470 5-1.4
004	AR	11 14191401	INK	BLACK	003	1	48 80368111	TRANSISTOR	MP5820 SCREENED	005	1	06 1067451	RESISTOR	33 2.1 1.8
C 001	1	21401109	CAPACITOR	05UF 20-80 80C	004	1	48 80368111	TRANSISTOR	MP5820 SCREENED	002	1	06 1067458	RESISTOR	39 2.1 1.8
C 002	1	23 80396A40	CAPACITOR	10UF 20-25	005	1	48 80368111	TRANSISTOR	MP5820 SCREENED	003	1	6512441	RESISTOR	475 5-1.4
C 003	1	2308341815	CAPACITOR	1.0UF 20-25	006	1	48 80368111	TRANSISTOR	MP5820 SCREENED	004	1	180834370	RESISTOR VARIABLE	100
C 004	1	23 80396A40	CAPACITOR	10UF 20-25	007	1	48 80368111	TRANSISTOR	MP5820 SCREENED	000	1	180834370	RESISTOR VARIABLE	100
C 005	1	2308397023	CAPACITOR	6.8UF 20-20	008	1	48 80368111	TRANSISTOR	MP5820 SCREENED	006	1	6512447	RESISTOR	820 5-1.4
C 006	1	2308397023	CAPACITOR	6.8UF 20-20	009	1	48 80368111	TRANSISTOR	MP5619 SCREENED	007	1	6512441	RESISTOR	470 5-1.4
C 007	1	21 80396A40	CAPACITOR	1UF 20-100	010	1	48 80368111	TRANSISTOR	MP5820 SCREENED	008	1	6512441	RESISTOR	470 5-1.4
C 010	1	2105142810	CAPACITOR	0.01UF 20-300	011	1	48 80368111	TRANSISTOR	MP5820 SCREENED	009	1	6512441	RESISTOR	470 5-1.4
C 011	1	20 80378A32	CAPACITOR	2 TO 8P7 250V	012	1	48 80368111	TRANSISTOR	MP5820 SCREENED	000	1	6512441	RESISTOR	470 5-1.4
C 012	1	21 80396A40	CAPACITOR	1000PF 10-100	014	1	48 80368111	TRANSISTOR	MP5820 SCREENED	002	1	6512441	RESISTOR	470 5-1.4
C 013	1	21 80396A40	CAPACITOR	33P 5-500	001	1	65 12445	RESISTOR	4 74 5-1.4	003	1	6512441	RESISTOR	470 5-1.4
C 014	1	2108494819	CAPACITOR	470PF 5-500	005	1	65 12445	RESISTOR	4 74 5-1.4	004	1	6512441	RESISTOR	470 5-1.4
C 015	1	21 80396A40	CAPACITOR	470PF 5-500	006	1	65 12445	RESISTOR	4 74 5-1.4	005	1	6512441	RESISTOR	470 5-1.4
C 016	1	21 80396A40	CAPACITOR	1UF 20-100	007	1	65 12447	RESISTOR	100K 5-1.4	006	1	6512441	RESISTOR	470 5-1.4
C 017	1	21 80396A40	CAPACITOR	1UF 20-100	008	1	65 12473	RESISTOR	10K 5-1.4	007	1	51 80368A0	RESISTOR	10K
C 018	1	21 80396A40	CAPACITOR	1UF 20-100	009	1	65 12445	RESISTOR	4 74 5-1.4	008	1	51 80368A0	RESISTOR	10K
C 019	1	21 80396A52	CAPACITOR	01UF 20-80 20C	010	1	65 12445	RESISTOR	4 74 5-1.4	009	1	51 80368A0	RESISTOR	10K
C 020	1	21 80396A51	CAPACITOR	1000PF 10-100	011	1	06 80296A7	RESISTOR	909K 1.1W 800	010	1	51 80368A0	RESISTOR	10K
C 021	1	21 80396A48	CAPACITOR	22P 5-500	012	1	06 80396A7	RESISTOR	90 9K 1.1.4	011	1	51 80368A0	RESISTOR	10K
C 022	1	21 80396A52	CAPACITOR	01UF 20-80 20C	013	1	06 80396A7	RESISTOR	909K 1.1.4	012	1	51 80368A0	RESISTOR	10K
C 023	1	2108494834	CAPACITOR	68P 5-500	014	1	06 80396A7	RESISTOR	10K 1.1.4	013	1	51 80368A0	RESISTOR	10K
C 024	1	21 80396A48	CAPACITOR	15P 5-500	015	1	06 80396A7	RESISTOR	10K 1.1.4	014	1	6518433	RESISTOR	290 5-1.8
C 025	1	21 80396A48	CAPACITOR	1UF 20-100	016	1	65 12445	RESISTOR	4 74 5-1.4	015	1	6512449	RESISTOR	2700 5-1.4
C 026	1	21C8372C08	CAPACITOR	2UF - 80 20 25	017	1	65 12445	RESISTOR	4 74 5-1.4	016	1	6512449	RESISTOR	2700 5-1.4
C 027	1	21082187807	CAPACITOR	470PF 10-500	018	1	65 12445	RESISTOR	4 74 5-1.4	017	1	6512447	RESISTOR	10K 5-1.4
C 028	1	21082188306	CAPACITOR	2000PF 10-500	019	1	180834370	RESISTOR VARIABLE	500	018	09 80331A8	JACK 10	WMT	
C 029	1	21C8372C10	CAPACITOR	05UF 20 25	020	1	06 1062155	RESISTOR	4200 1.1 8	001	1	51 8054508	INTEGRATED CIRCUIT	LM318 P 8 0 SCREENE
C 030	1	21 80396A48	CAPACITOR	1UF 20-100	021	1	65 12418	RESISTOR	51 5-1.4	002	1	51 8034507	INTEGRATED CIRCUIT	LM320P 8 0 SCREENE
C 031	1	21 80396A48	CAPACITOR	1UF 20-100	022	1	65 12448	RESISTOR	51 5-1.4	003	1	51 8034503	INTEGRATED CIRCUIT	CA138E SCREENED
C 032	1	21 80396A48	CAPACITOR	1UF 20-100	023	1	65 12447	RESISTOR	5 84 5-1.4	004	1	51 8054504	INTEGRATED CIRCUIT	CA3140E SCREENED
C 033	1	2308478118	CAPACITOR	47UF 20-10	024	1	65 12447	RESISTOR	5 84 5-1.4	005	1	51 80368A2	INTEGRATED CIRCUIT	LM300A SCREENED
C 034	1	2308478118	CAPACITOR	47UF 20-10	025	1	180834370	RESISTOR VARIABLE	2K	006	1	51 80368A4	INTEGRATED CIRCUIT	MC1408BP SCREENE
C 035	1	2108187828	CAPACITOR	390PF 10-500	026	1	06 1062151	RESISTOR	2800 1.1 8	007	1	51 8032660	INTEGRATED CIRCUIT	MC1611P SCREENED
C 036	1	21082187828	CAPACITOR	390PF 10-500	027	1	06 1062111	RESISTOR	1470 1.1 8	008	1	51 80368A8	INTEGRATED CIRCUIT	MC1408B SCREENED
CR001	1	48 84463X02	DIODE		028	1	06 1062184	RESISTOR	511 1.1 8	009	1	51 80368A9	INTEGRATED CIRCUIT	MC1408B SCREENED
CR002	1	48 84463X02	DIODE		029	1	06 1062187A	RESISTOR	196 1.1 8	010	1	51 80368A1	INTEGRATED CIRCUIT	MC145382CP SCREENE
CR003	1	48 84463X02	DIODE		030	1	06 1062115	RESISTOR	4200 1.1 8	011	1	51 80368A1	INTEGRATED CIRCUIT	MC145382CP SCREENE
CR004	1	48 84463X02	DIODE		031	1	06 1062189A	RESISTOR	511 1.1 8	012	1	51 80368A3	INTEGRATED CIRCUIT	MC14718CP SCREENE
CR005	1	48 84463X02	DIODE		032	1	06 10621890	RESISTOR	909 1.1 8	013	1	51 80368A7	INTEGRATED CIRCUIT	MC145382CP SCREENE
CR006	1	48 84463X02	DIODE		033	1	06 10621818	RESISTOR	261 1.1 8	014	1	51 80368A1	INTEGRATED CIRCUIT	MC145382CP SCREENE
CR007	1	48 84463X02	DIODE		034	1	65 12447	RESISTOR	10K 5-1.4	015	1	51 80368A1	INTEGRATED CIRCUIT	MC145382CP SCREENE
CR008	1	48 84463X02	DIODE		035	1	65 12443	RESISTOR	680 5-1.4	016	1	51 80368A3	INTEGRATED CIRCUIT	MC14718CP SCREENE
CR009	1	48 84463X02	DIODE		036	1	65 124481	RESISTOR	22K 5-1.4	017	1	51 80368A8	INTEGRATED CIRCUIT	MC145382CP SCREENE
CR010	1	48 84463X02	DIODE		037	1	65 124832	RESISTOR	390K 5-1.4	018	1	51 80368A1	INTEGRATED CIRCUIT	MC145382CP SCREENE
CR011	1	48 84463X02	DIODE		038	1	65 12487	RESISTOR	100K 5-1.4	019	1	51 80368A7	INTEGRATED CIRCUIT	MC145382CP SCREENE
J 001	1	09 80331A97	SOCKET SOLDER DIP		039	1	65 124814	RESISTOR	470K 5-1.4	020	1	51 80368A7	INTEGRATED CIRCUIT	MC145382CP SCREENE
J 002	1	09 80331A97	SOCKET SOLDER DIP		040	1	65 124814	RESISTOR	470K 5-1.4	021	1	51 8034522	INTEGRATED CIRCUIT	MC145382CP SCREENE
K 001	1	80 80346A01	RELAY REED	1A 500V	041	1	180834370	RESISTOR VARIABLE	50K	VR001	1	48 82256C8	DIODE ZENER	
K 002	1	80 80346A01	RELAY REED	1A 500V	042	1	06 1062187L	RESISTOR	24K 1.1 8					
K 003	1	80 80346A01	RELAY REED	1A 500V	043	1	65 124838	RESISTOR	4 74 5-1.4					
K 004	1	80 80346A01	RELAY REED	1A 500V	044	1	65 124838	RESISTOR	4 74 5-1.4					
K 005	1	80 80346A01	RELAY REED	1A 500V	045	1	06 1062187Z	RESISTOR	22K 1.1 8					
K 006	1	8008157801	REED RELAY	1A	046	1	06 10621433	RESISTOR	32 4K 1.1 8					
K 007	1	8008157801	REED RELAY	1A	047	1	06 1062151	RESISTOR	31 1.1 8					
K 008	1	8008157801	REED RELAY	1A	048	1	06 124922	RESISTOR	1M 5-1.4					

Figure 18-3. Front Panel Interface Module A12 (RTL-4086A) Parts Location Diagram (Sheet 2 of 2)

SECTION 19

10 MHz FREQUENCY STANDARD MODULE (A13)

19-1. General. The frequency Standard Module provides a stable 10 MHz source and the interface for an external 10 MHz input. A block diagram of the Frequency Standard Module is shown in figure 19-1 with its schematic shown in figure 19-2.

19-2. 10 MHz Oscillator and Control. The internal 10 MHz source is either a temperature compensated crystal oscillator (TCXO) or an optional ovenized crystal oscillator (OVXO). A voltage regulator on the module supplies the voltage to the oscillator and monitors the supply current. For the ovenized option, at power on, the oven draws high current. As the oven warms up the current decreases, reaching some low value when the operating temperature has been reached. A current detector illuminates the oven ready indicator when the current has decreased to the stabilized value. The indicator is continuously illuminated with the TCXO.

19-3. Internal/External Switchover. With no signal at the external 10 MHz input jack, the internal oscillator is gated to the SYNTH 10 MHz and the external 10 MHz OUT signal paths. When an external 10 MHz input is applied the switchover circuitry detects its presence, removes the power from the internal oscillator, and gates the external input to the SYNTH 10 MHz and external 10 MHz OUT signal paths. The oven ready indicator is extinguished when the system is operating from an external standard.

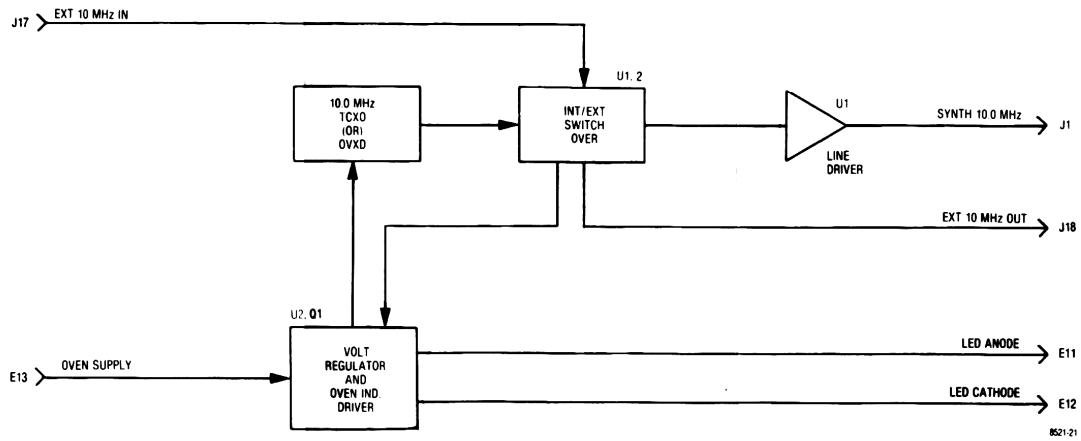
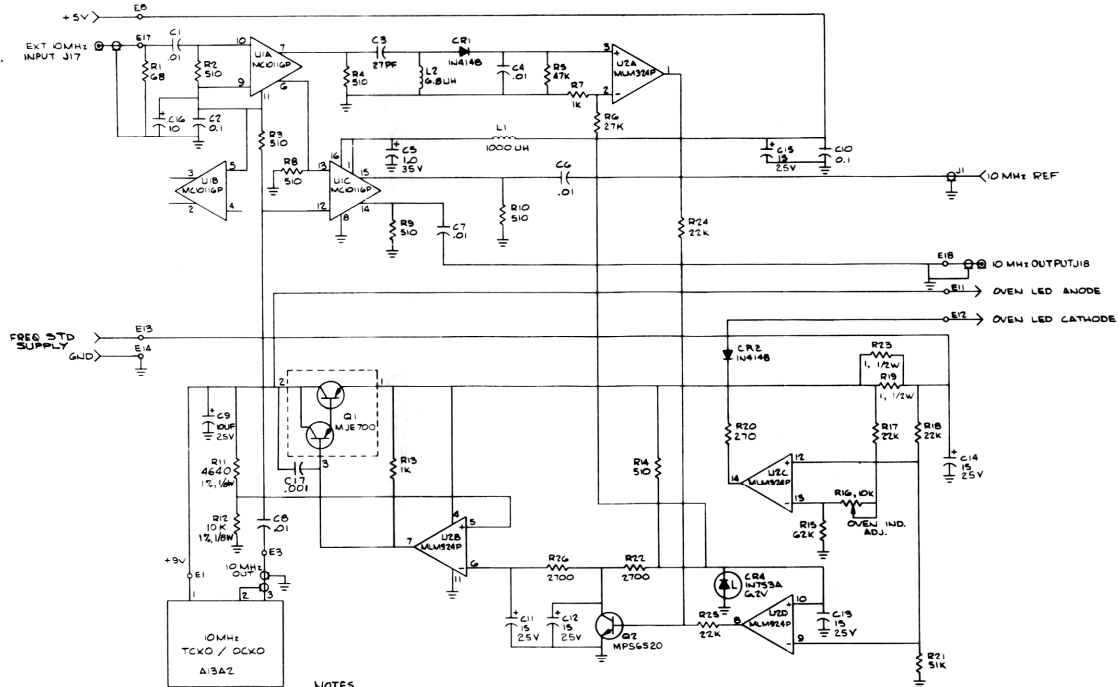

Figure 19-1. Frequency Standard Module A13
Block Diagram



- NOTES
1. TOP ASSY A13 01-P07895V
A13A1 01-P0037544002
PWB ASSY A13A1 01-P0037544002
A13A2 02XO 58-P003554
A13A2 TCXO 58-P003554
 2. CAPACITORS ARE IN UF UNLESS NOTED
 3. RESISTORS ARE 1/4 W UNLESS NOTED

Figure 19-2. Frequency Standard Module A13
Schematic Diagram

Find No.	Qty Req.	Part No.	Nomenclature	Part Value
A13	1	RTL-1011A	FREQUENCY STANDARD	
003	1	01-7030805001	BRACKET DISC	
004	7	03-336681	SCREWS	440X.312
005	7	04-114583	WASHER LOCK	112
006	4	04-1507	WASHER FLAT	125
009	AR	30-84421F13	CABLE,RF	WHT
010	2	1107-A-2	SPRINK	
011	1	84-706880001	PLATE CONNECTOR M	
012	1	29-15122A17	TERMINAL LUG	
013	AR		WIRE	#22 WHT
014	AR	5N62WRP3	SOLDER	
015	AR	11-44167A01	INK	BLACK
016	1	14-14348408	INSULATOR,LMCA	
017	AR		WIRE	#22 WHT
018	3	NA6620C4	WASHER	ND4
019	AR	M02063-204-C	INSULATION BLEEVIN	105 CLR
020	AR		WIRE #16 IN DIA	#16
A1001	1	RTL-4046B	10MHZ STD W/INTERFAC	
A1002	1	01-80037A08	REF DISC,10MHZ TCK00	
J1017	1	09-80331A09	CONNECTOR,RF	
J1018	1	09-80331A08	CONNECTOR,RF	

Figure 19-3. Frequency Standard Module A13 (RTL-1011A) Parts Location Diagram

Find No.	Qty Req.	Part No.	Nomenclature	Part Value
		RTL-4046B	10MHZ INTERFACE	
001	1	84-80335A20	PWB,10MHZ INTERFAC	
002	AR	5N62WRP3	SOLDER	
003	AR	11-14167A01	INK	BLACK
004	AR	5N96WRM4P3	SOLDER	
C 001	1	21-80396A52	CAPACITOR	01UF .20 + 80-200
C 002	1	21-80396A82	CAPACITOR	1UF .20-100
C 003	1	21D84494B42	CAPACITOR	27PF .5-500
C 004	1	21-80396A52	CAPACITOR	01UF .20 + 80-200
C 005	1	23D28411D15	CAPACITOR	1.0UF .20-35
C 006	1	21-80396A52	CAPACITOR	01UF .20 + 80-200
C 007	1	21-80396A52	CAPACITOR	01UF .20 + 80-200
C 008	1	21-80396A52	CAPACITOR	01UF .20 + 80-200
C 009	1	23-80396A40	CAPACITOR	10UF .25V
C 010	1	21-80396A82	CAPACITOR	1UF .20-100
C 011	1	23-80396A41	CAPACITOR	15UF .25V
C 012	1	23-80396A41	CAPACITOR	15UF .25V
C 013	1	23-80396A41	CAPACITOR	15UF .25V
C 014	1	23-80396A41	CAPACITOR	15UF .25V
C 015	1	23-80396A41	CAPACITOR	15UF .25V
C 016	1	23-80396A40	CAPACITOR	10UF .25V
C 017	1	21-80396A52	CAPACITOR	01UF .20 + 80-200
CR001	1	48-84463K02	DIODE	
CR002	1	48-84463K02	DIODE	
CR004	1	48-84302A09	DIODE,ZENER	6.2V .5-4
J 001	1	801	CONNECTOR,PHONE JA	
L 001	1	24-80368A42	COIL	1000UH
L 002	1	24-80368A16	CHOKE	
Q 001	1	48-80321A06	TRANSISTOR	
Q 002	1	48-80368A91	TRANSISTOR	MP6520 SCREENED

- NOTES:
- FOR REFERENCE DOCUMENTS REFER TO SCHEMATIC DIAG.
 - PARTIAL REFERENCE DESIGNATIONS ARE SHOWN FOR COMPLETE DESIGNATION PREFIX WITH A13.
 - SOLDER ALL ELECTRICAL CONNECTIONS IN ACCORDANCE WITH REQUIREMENT OF MIL-STD-883C USING FIND NO. 14.
- ⚠ INSTALL FIND NO. 18 BETWEEN TRANSISTOR ON A1 AND BRACKET FIND NO. 3.
- ⚠ TERMINATION LOCATIONS ARE SHOWN FOR REFERENCE ONLY AND ARE NOT TO BE ADDED ON THE ASSEMBLY.
- ⚠ SOLDER COAX CABLE SHIELDS TO P.W.B. AND CONNECTORS USING FIND NO. 14 AND 10.
- ⚠ WAVE SERIAL NUMBER A13 AND PART NUMBER 01-80396V-1 IN ACCORDANCE WITH MIL-STD-130 IN 12 MIN. HIGH GROSS CHARACTERISTICS USING FIND NO. 13.

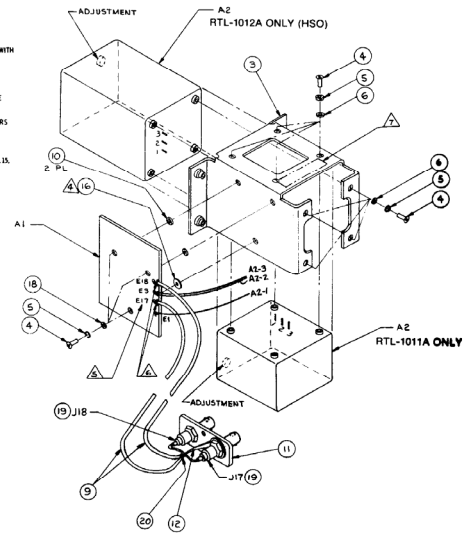

Figure 19-4. Frequency Standard Module A13 PWB Parts Location Diagram

Find No.	Qty Req.	Part No.	Nomenclature	Part Value
R 025	1	6S124A81	RESISTOR	22K-5-1/4
R 026	1	6S124A59	RESISTOR	2.7K-5-1/4
U 001	1	51-80320A60	INTEGRATED CIRCUIT	MC10116P SCREENED
U 002	1	51-80396A16	INTEGRATED CIRCUIT	LM324N SCREENED
R 001	1	6S124A21	RESISTOR	68.5-1/4
R 002	1	6S124A42	RESISTOR	510.5-1/4
R 003	1	6S124A42	RESISTOR	510.5-1/4
R 004	1	6S124A42	RESISTOR	510.5-1/4
R 005	1	6S124A88	RESISTOR	47K-5-1/4
R 006	1	6S124A83	RESISTOR	27K-5-1/4
R 007	1	6S124A49	RESISTOR	1K-5-1/4
R 008	1	6S124A42	RESISTOR	510.5-1/4
R 009	1	6S124A42	RESISTOR	510.5-1/4
R 010	1	6S124A42	RESISTOR	510.5-1/4
R 011	1	06-10821C59	RESISTOR	4640-1-1/8
R 012	1	06-10821C51	RESISTOR	10K-1-1/8
R 013	1	6S124A49	RESISTOR	1K-5-1/4
R 014	1	6S124A42	RESISTOR	510.5-1/4
R 015	1	6S124A92	RESISTOR	62K-5-1/4
R 016	1	180B8452P14	RESISTOR,VARIABLE	10K
R 017	1	6S124A81	RESISTOR	22K-5-1/4
R 018	1	6S124A81	RESISTOR	22K-5-1/4
R 019	1	6S125B70	RESISTOR	1.5-1/2
R 020	1	6S124A35	RESISTOR	270.5-1/4
R 021	1	6S124A50	RESISTOR	51K-5-1/4
R 022	1	6S124A59	RESISTOR	2.7K-5-1/4
R 023	1	6S125B70	RESISTOR	1.5-1/2
R 024	1	6S124A81	RESISTOR	22K-5-1/4

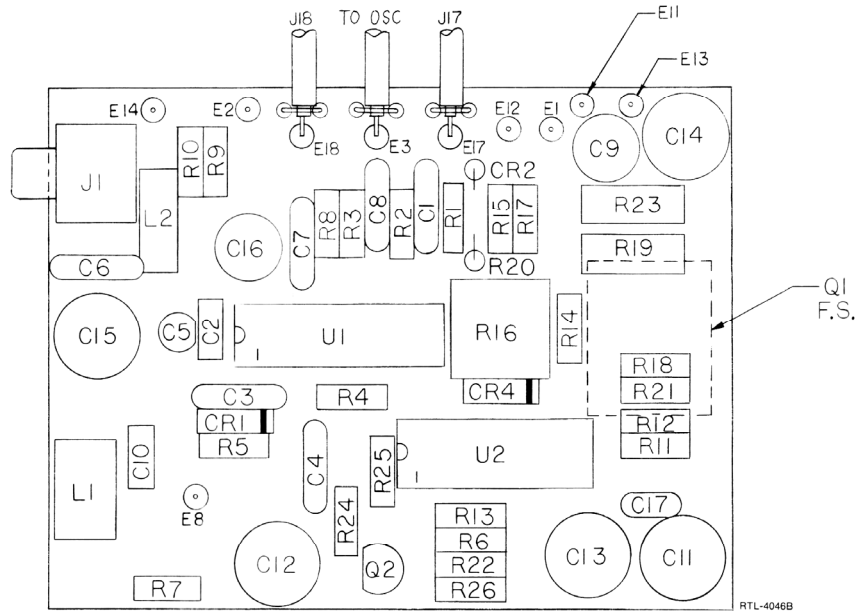

Figure 19-4. Frequency Standard Module
 A13 PWB Parts Location
 Diagram (Sheet 1 of 2)

SECTION 20 FRONT PANEL (A14)

20-1. GENERAL. The front panel assembly consists of a display board module and the analyzer operating switches and controls. A schematic diagram of the front panel assembly is shown in figure 20-1.

20-2. DISPLAY BOARD. The display board holds and decodes LED data. A display of 27 LEDs is driven by 24 drivers and three inputs from external sources. The keyboard is a 5-row by 4-column matrix of momentary contact switches. Jumper connections on the board are used to route signals between connectors. The display board consists of three latch/decoders, 24 LED drivers, and a 27 LED display. A display board block diagram is shown in figure 20-2.

20-3. The three latch/decoders hold and decode input data from the AF DATA BUS 0-3. Signals $\overline{LS0}$ - $\overline{LS2}$ are latch selects that transfer data from the AF DATA BUS 0-3 to the corresponding latch. Only one LED at a time can be turned on by any of the three latch selects. Each driver is an open-collector device which sinks current through its respective LED.

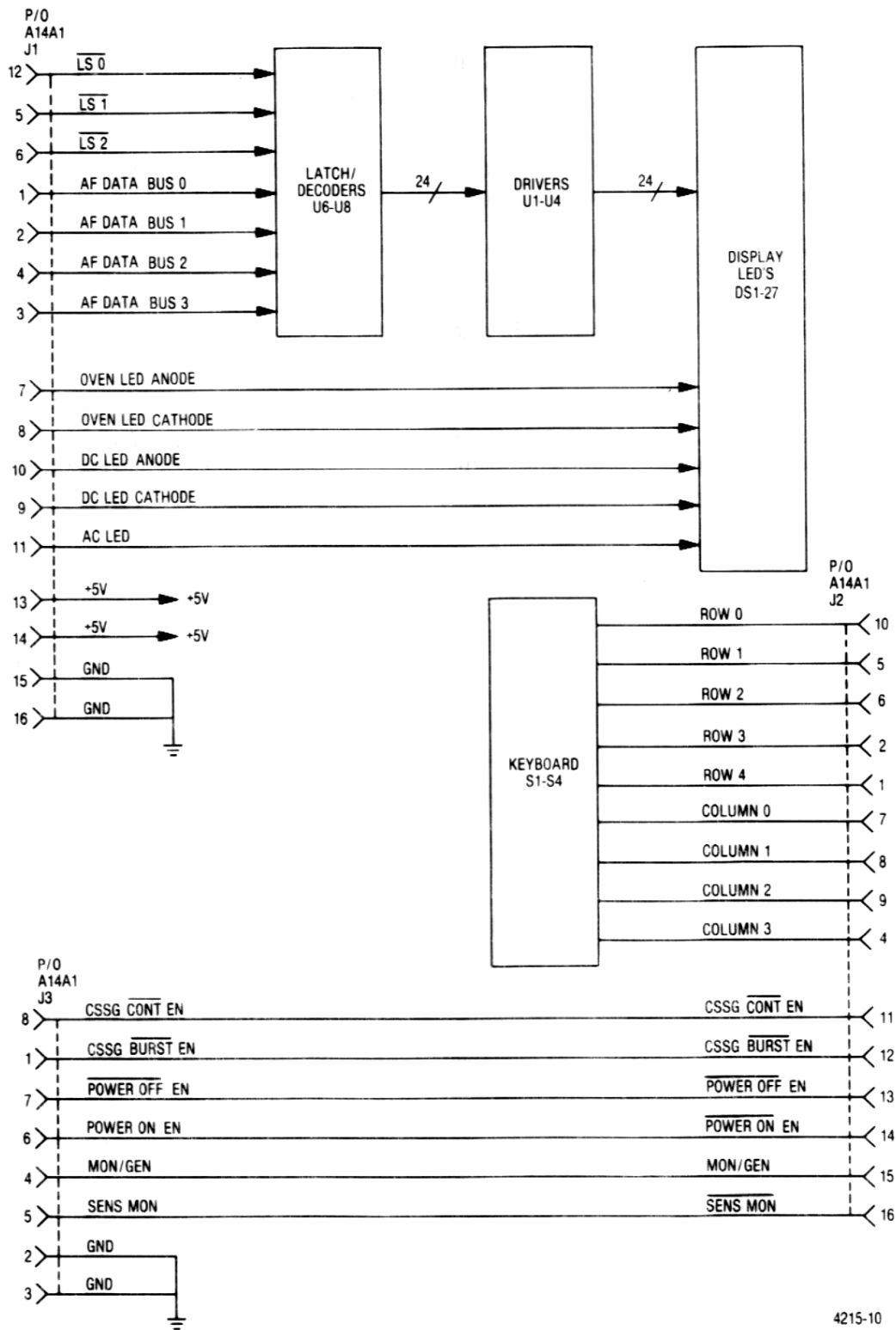

Figure 20-3. Display Board A14A1 Block Diagram

- NOTES:
- PARTIAL REFERENCE DESIGNATIONS ARE GIVEN FOR COMPLETE DESIGNATION PER MIL-STD-883C.
 - SEE REFERENCE DRAWING FOR TO: BLD-PROB-883C PARTS LIST OR REFER TO ASSEMBLY DRAWING.
 - UNLESS OTHERWISE SPECIFIED ALL RESISTORS ARE 1/4 OHM, 2.5K, 1/4WAT, ALL VOLTAGES ARE DC.
 - DEVICE TYPE AND CONNECTIONS NOT SHOWN ON SYMBOL ARE GIVEN IN TABLE 1. UNDERLINE POSITION OF TYPE NUMBER IS USED AS A CODE TO IDENTIFY REFERENCE PROGRAM.
 - ALL DIMS ARE IN MILS.

TABLE 1

REF	DEVICE TYPE	NO. OF PINS	NO. OF PINS	NO. OF PINS
U1	MC14514	8	9	6,7,10,11
U2	MC14514	8	9	7,10
U3	MC14514	8	9	7,10
U4	MC14514	8	9	7,10
U5	MC14514	8	9	7,10,13
U6	MC14514	8	9	4,5,13,10,13
U7	MC14514	8	9	4,5,13,10,13
U8	MC14514	8	9	4,5,13,10,13
U9	MC14514	8	9	14

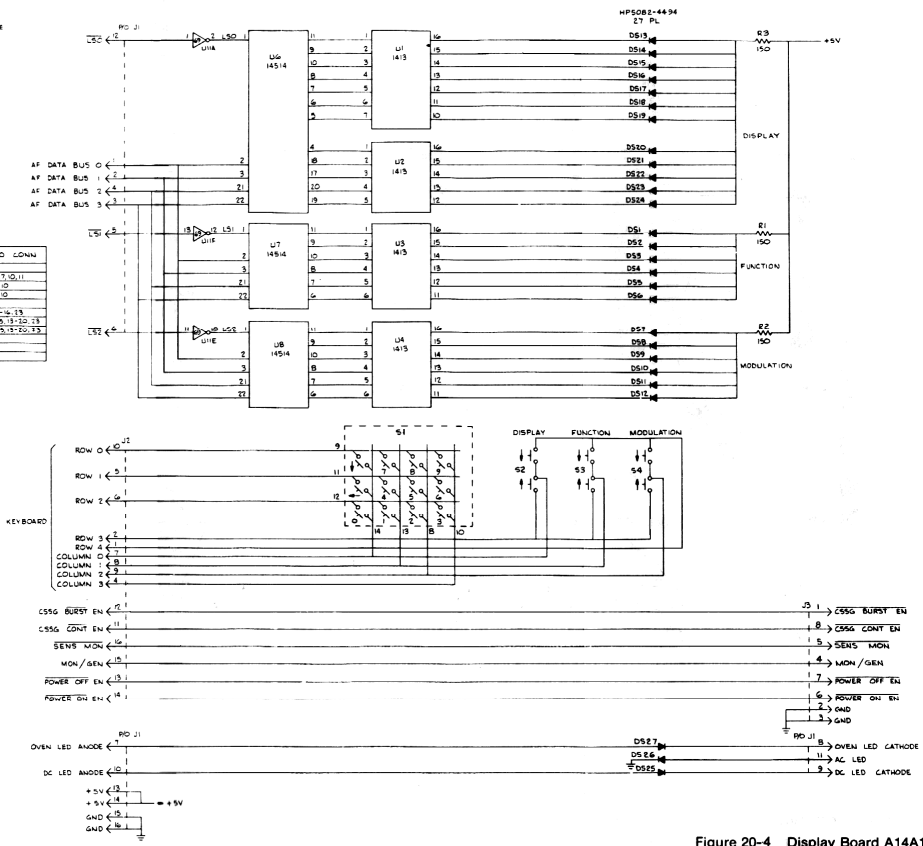

Figure 20-4 Display Board A14A1 Schematic Diagram

Part No.	Qty	Part No.	Nomenclature	Part Value
001	1	84-20784V001	PWB DISPLAY	BLACK
002	AR	11-14187A01	INK	
004	2	5807314	SOCKET 12 PIN	
005	AR	5M037M0AP3	SOLDER	
006	1	1-583773.3	SOCKET 8 PIN	
007	2	43-106403007	SPACER	
008	4	43-106403012	SPACER	
011	2	81134-B-1-B5	SPACER/SWAGE	
012	2	03-136A1	SCREW PIN	
013	AR		COMPOUND THD LKGP	
015	1	2-583773.6	SOCKET 24 PIN	
016	AR	49-04	ADHESIVE/FAST CURE	
D5001	1	48-80396A26	LED	
D5002	1	48-80396A26	LED	
D5003	1	48-80396A26	LED	
D5004	1	48-80396A26	LED	
D5005	1	48-80396A26	LED	
D5006	1	48-80396A26	LED	
D5007	1	48-80396A26	LED	
D5008	1	48-80396A26	LED	
D5009	1	48-80396A26	LED	
D5010	1	48-80396A26	LED	
D5011	1	48-80396A26	LED	
D5012	1	48-80396A26	LED	
D5013	1	48-80396A26	LED	
D5014	1	48-80396A26	LED	
D5015	1	48-80396A26	LED	
D5016	1	48-80396A26	LED	
D5017	1	48-80396A26	LED	
D5018	1	48-80396A26	LED	
D5019	1	48-80396A26	LED	
D5020	1	48-80396A26	LED	
D5021	1	48-80396A26	LED	
D5022	1	48-80396A26	LED	
D5023	1	48-80396A26	LED	
D5024	1	48-80396A26	LED	
D5025	1	48-80396A26	LED	
D5026	1	48-80396A26	LED	
D5027	1	48-80396A26	LED	
J001	1	09-80331A7	SOCKET SOLDER DIP	18 PIN
J002	1	09-80331A6	SOCKET SOLDER DIP	18 PIN
J003	1	09-80331A5	SOCKET SOLDER DIP	
R001	1	8512A29	RESISTOR	150-5.1 K
R002	1	8512A29	RESISTOR	150-5.1 K
R003	1	8512A29	RESISTOR	150-5.1 K
S001	1	40-80286A32	SWITCH PUSH/BUTTON	12 POS
S002	1	40-80286A32	SWITCH PUSH/BUTTON	2 POS
S003	1	40-80286A32	SWITCH PUSH/BUTTON	2 POS
S004	1	40-80286A32	SWITCH PUSH/BUTTON	2 POS
U001	1	51-80345A1	INTEGRATED CIRCUIT	MC14514P SCREENED
U002	1	51-80345A1	INTEGRATED CIRCUIT	MC14514P SCREENED
U003	1	51-80345A1	INTEGRATED CIRCUIT	MC14514P SCREENED
U004	1	51-80345A1	INTEGRATED CIRCUIT	MC14514P SCREENED
U005	1	51-80368A49	INTEGRATED CIRCUIT	MC14514BCP SCREENED
U006	1	51-80368A49	INTEGRATED CIRCUIT	MC14514BCP SCREENED
U007	1	51-80368A49	INTEGRATED CIRCUIT	MC14514BCP SCREENED
U008	1	51-80368A49	INTEGRATED CIRCUIT	MC14514BCP SCREENED
U009	1	51-80368A49	INTEGRATED CIRCUIT	MC14514BCP SCREENED

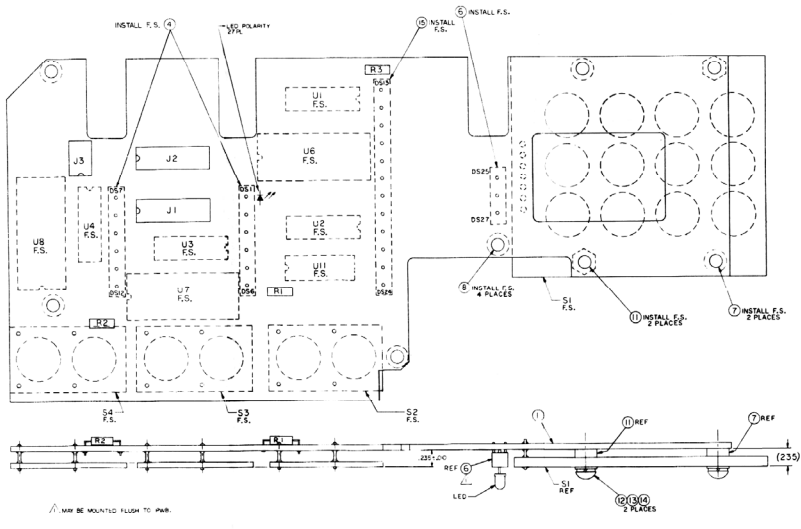
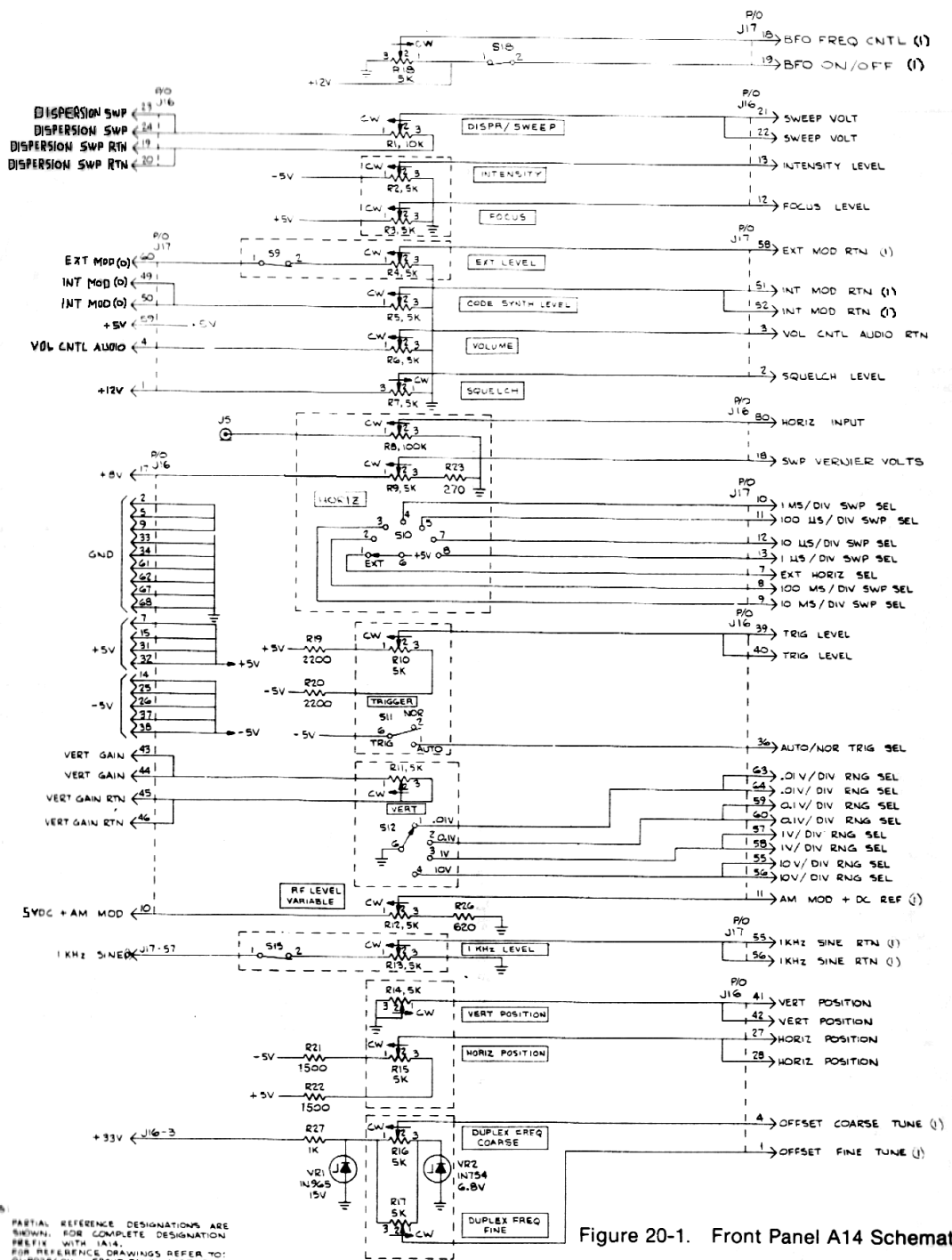

Figure 20-5. Display Board A14A1 (1-80305A63) Parts Location Diagram



- NOTES
- PARTIAL REFERENCE DESIGNATIONS ARE SHOWN. FOR COMPLETE DESIGNATION PREFIX WITH IAS.
 - FOR REFERENCE DRAWINGS REFER TO:
 - 01-P071860V FRONT PANEL ASSEMBLY
 - 01-P071843V DISPLAY BD ASSEMBLY
 - 01-P071899V DISPLAY BD SCHEMATIC
 - 01-P071868V SWITCH PUB ASSEMBLY
 - UNLESS OTHERWISE SPECIFIED:
 - ALL RESISTORS ARE IN OHMS, 0.5WATT, 1/4 WATT.
 - ALL VOLTAGES ARE DC.
- APPLIES TO IEEE OPTION ONLY. FOR REFERENCE DRAWING SEE: 01-P071860V FRONT PANEL ASSEMBLY

Figure 20-1. Front Panel A14 Schematic Diagram (Sheet 1 of 2)

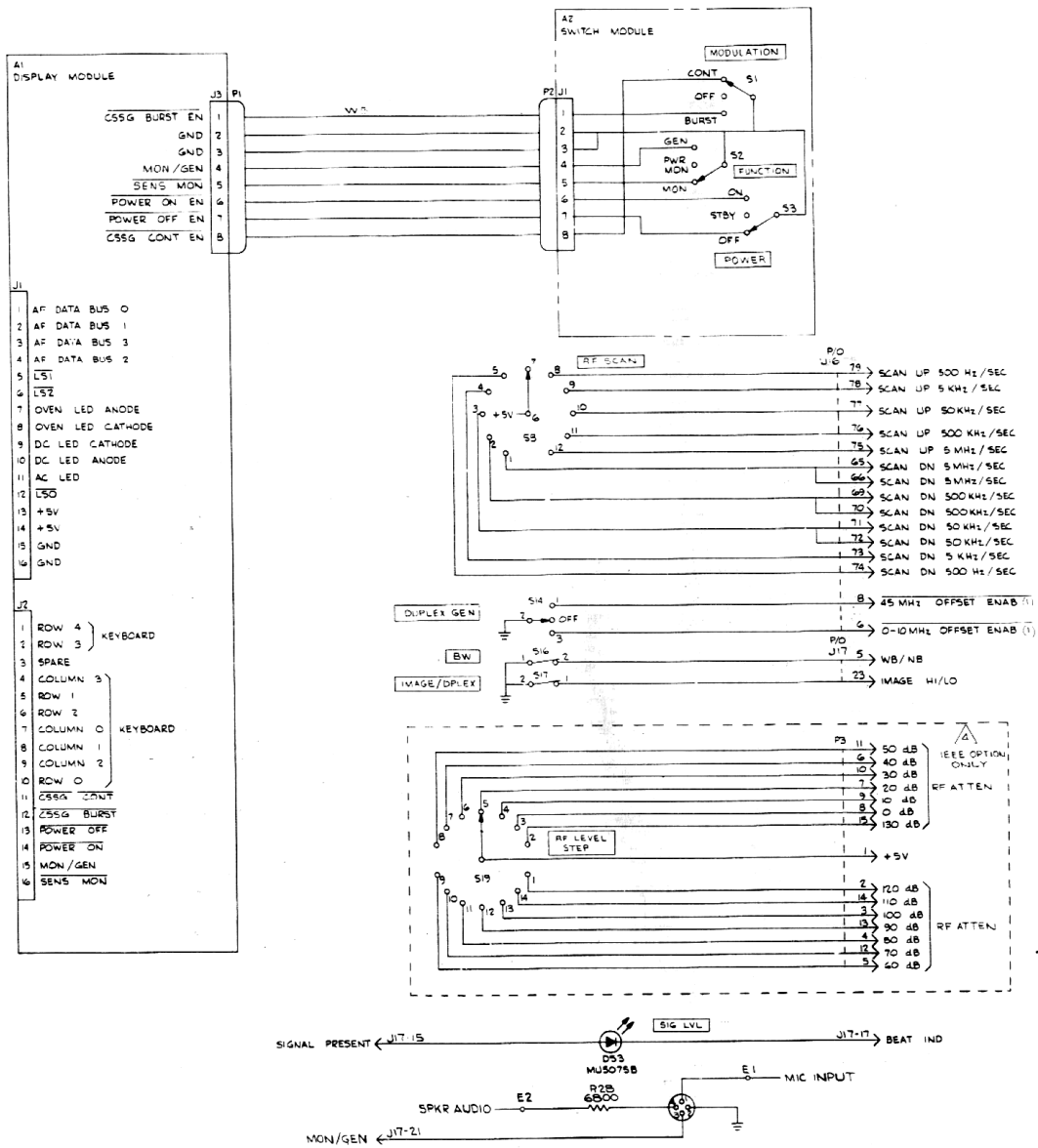

Figure 20-1. Front Panel A14 Schematic Diagram (Sheet 2 of 2)

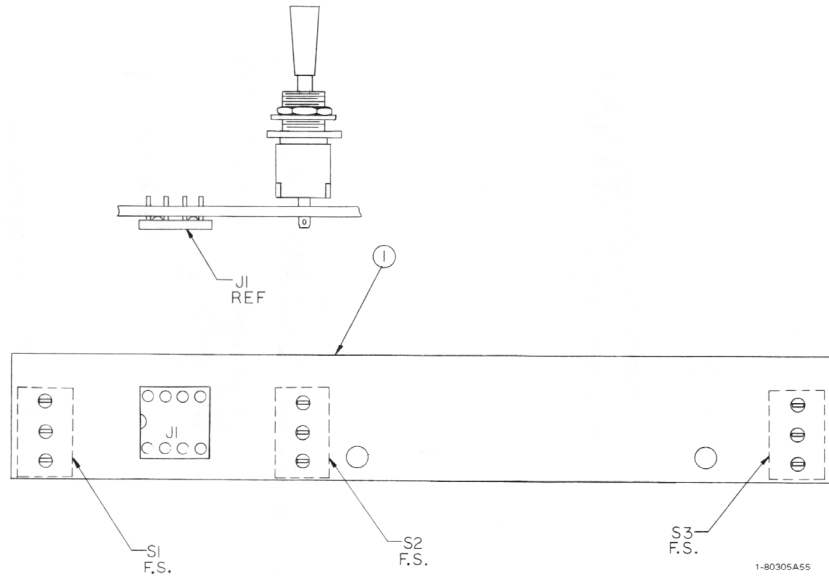

Figure 20-2 Front Panel A14 (01-80305A64) Parts
 Location Diagram (Sheet 3 of 3)

SECTION 21

IEEE — 488 BUS CONTROL

21-1. INTRODUCTION

21-2. The IEEE Interface Option enables the use of the Communications System Analyzer as a programmable measurement instrument. When combined with a suitable programmable controller and applications software, the major functions of the analyzer can be controlled or monitored via an IEEE-488 standard digital interface. Thus, repetitive test routines can be performed and the data recorded quickly and accurately with little operator interaction.

21-3. The interface characteristics conform to the specifications of the IEEE Standard Digital Interface for Programmable Instrumentation (IEEE Standard 488) which defines both the electrical and the mechanical interface. Control protocol is also defined by the specification. Control commands which are unique to the analyzer are described in detail in the following paragraphs of this section.

21-4. The controller for this application should be capable of reading and writing ASCII and control characters from and to the bus in accordance with the 488 specification. Application software is the user's responsibility as dictated by the controller selected, although interface and application assistance is available from Motorola.

21-5. The IEEE option package consists of an IEEE Interface module (A8) with a rear panel connector, an electrically programmable RF attenuator in place of the step attenuator on the RF Input Module (A11), a fourteen position rotary switch on the front panel in place of the step attenuator shaft, and one additional ROM memory IC on the Processor module (A9).

21-6. While in the local mode the IEEE-488 equipped system operates and performs the same as a standard system, except the maximum RF output level is reduced to +11 dBm from +13 dBm. However, when the Remote Enable (REN) line on the IEEE Bus is activated many of the front panel controls are disabled and their functions placed under bus control. Refer to table 21-1 for a listing of those functions which can be controlled or monitored via the 488 Bus.

Table 21-1. IEEE-488 Interface Controllable Functions

Control/Measurement	Comment	Control/Measurement	Comment
Function Switch	Generate/Power Monitor/ Monitor (Note 1)	RF Frequency	Frequency entry to be supplied by program
Modulation Control	Continuous/OFF/BLURST	PL Frequency	Frequencies not available from memory table
Wideband/Narrowband Switch		DPL Cont	
Image High/Low Switch		Tone A Frequency	
Time Sequence Select	Sequences 1 through 5 only (Note 2)	Tone B Frequency	
Duplex Oscillator Switch	1-10 MHz/OFF/45 MHz	External Modulation	Modulation settable to any measurable level
Keyboard	Numeric Entries 0-9 Can be transmitted to the bus	Code Synthesizer Modulation	(0-20 KHz deviation in 10 Hz steps) (Note 3) (0-90% AM in 0.1% steps)
Display Mode	Generate/Monitor/Meters (Note 1) Modulation Spectrum Analyzer Duplex Generator RF Memory Tone Memory Frequency Counter DVM External Wattmeter IF Scope AC Scope DC Remote Terminal Mode Unit can also display a subset of ASCII characters (numbers 0-9, upper case alpha letters A-Z, plus other symbols—ASCII characters 20 thru 5F. Hexadecimal address display of operator messages on CAT display in a transparent terminal mode)	RF level	RF level settable to any measurable level (1:10 to 1:1 when in 0.1 dBm steps) (Note 3) (Note 4)
Function Mode	FM (Note 1) CW AM SSB/DSB SWP 1-10 MHz SWP 0.01-1 MHz	Scope Vertical Step Attenuator	0.01, 0.1, 1, 10 volts
Code Synthesizer Mode	PL/DPL PL/DPL Invert Tone A Tone B Time Sequence Tone Remote	Horizontal Scope Sweep	1, 10, 100 milliseconds 1, 10, 100 microseconds External
		Input Power Meter	Frequency Error Deviation - or - 3, AM, or BINAD Reading returned as displayed on screen (Note 3)
		External DVM (AC or DC)	
		External Frequency Count	
		External Power Meter PWD/REV	

Notes: (1) May be affected by other controls (see below).
(2) Sequence 5 timing is programmable under IEEE bus control.
(3) As reading is displayed, LED corresponding to measurement mode and function mode are illuminated.
(4) The IEEE-Bus option, due to a change in the RF step attenuator, restricts the maximum RF output to +10 dBm.

NON-CONTROLLABLE FUNCTIONS

Since control and monitor functions of the interface are implemented to obtain remote measurement capability, certain front panel controls are not implemented in the interface due to their local operator orientation. A list of these operator oriented controls are as follows:

- | | | |
|--------------------------------|---------------------------|---|
| Power On/Off | Scope Vertical Position | Deviation Limit |
| Power Mode Indicators | Scope Horizontal Position | Battery Voltage Reading |
| Display Focus | Receiver Squelch | Deviation Limit Alarm (Disabled Under Remote Control) |
| Display Intensity | Receiver Volume | Attenuator 0 Indicator |
| Dispersion/Sweep | Zero Beat Indicator | Battery Below Limit Warning |
| Scope/DVM Vertical Vernier | RF Scan | BFO Frequency Adjust |
| Scope Trigger Level | RF Memory Table | Offset Oscillator Adjust |
| Scope Trigger Slope | | Mobile Telephone Tone 1 and Tone 2 Frequencies |
| Scope Horizontal Sweep Vernier | | |

21-7. IEEE-488 BUS STRUCTURE

21-8. The following discussion briefly describes the 488 Bus operation. It is not a complete definition of the total bus structure or capability. For complete information a copy of IEEE Standard 488 should be obtained.

21-9. **Bus Signals.** The IEEE-488 Bus consists of 16 parallel lines. The lines are divided into three groups. Lines D101-D108, Data Input Output, form the 8-bit data bus for the bidirectional transfer of control and ASCII characters. Three handshake lines, Data Valid (DAV), Not Ready for Data (NRFD), and Not Data Accepted (NDAC), control the transfer of data on the data bus. The remaining five lines can be termed the bus management lines with functions as follows:

- | | |
|-----------------------|--|
| Attention (ATN) | — When true the data bus carries an address or a command when false it carries data. |
| Interface Clear (IFC) | — When true all devices on the bus are placed in a known quiescent state. |
| Service Request (SRQ) | — Indicates a device on the bus needs service. |
| Remote Enable (REN) | — Enables the remote control feature of the devices on the bus. |
| End or Identify (EOI) | — Indicates the end of a multiple byte transfer. |

21-10. **Data Transfer.** Each byte of data that is transferred across the data bus is synchronized with a handshaking procedure. This procedure allows devices with different data transfer rates to share the same bus. The handshake cycle starts when the source device which has data to transfer checks for a false condition on the NRFD line. When NRFD is false, all devices on the bus are ready to accept data. The source then puts the data onto the data bus and sets the DAV to its true state. The acceptor devices inputs the data, sets the NRFD line to its true state, and when ready set the NDAC line to its false state. Because the NRFD and NDAC lines are wire-ORed the line will not go to the false state until all devices on the bus have released the line. Thus the slowest device on the bus determines the transfer rate. When the NDAC line goes false the source devices set the DAV false which in turn causes the acceptor devices to set the NDAC line true. When the acceptor devices have completed processing the data byte just received they allow the NRFD line to go to the false state completing the handshake. As the data transfer continues the cycle repeats for each data byte.

21-11. **Bus Address.** Each device on the bus is assigned a four bit address by the programmer. The address assigned to the device is set by an address switch within the device. On the analyzer the address switch is on the IEEE Interface Module. Only the top four switches are used to set the address. The fifth switch is unused. To set the address use the binary equivalent of the address number and set the switches to the ON position for a logic 1. The least significant bit is the top switch.

21-12. Programming

21-13. Programming the system analyzer consists of first addressing the unit as a listener, transferring the control commands to the unit, and then sending a command termination sequence. To obtain data from the system, the pertinent control commands are first transferred to the unit and then the unit is addressed as a talker. As a talker the system outputs onto the bus the data requested by the control commands.

21-14. The bus controller is the central part of the automatic system. The program, consisting of sequences of analyzer control commands and sequences of controller instructions for handling the return data, is contained within the controller. The user must initially write the program so that the desired test sequences and data outputs will be obtained. The following paragraphs define the instruction set and data formats that can be used to control or will be returned from the system analyzer. The user must insure that the controller is compatible with the IEEE-488 Standard bus and that its program is correct for the instruments on the bus.

21-15. Command Structure. Each command consists of a two letter definition prefix followed by a numeric data field. The data field will vary in length and structure according to the definition prefix as shown in table 21-3. Spaces may be inserted anywhere in the command but are not required. Each letter or number of a command is transferred from the bus controller to the analyzer in ASCII format. ASCII defines a 7-bit digital code for each letter, number, and symbol commonly used in computer programming.

21-16. The first letter of the two letter prefix identifies a command category with the second letter identifying a particular command within that category. A listing of the command categories and the corresponding first letter is provided in table 21-2. A complete list of commands is shown in table 21-3.

Table 21-2. Command Categories

A	Audio Synthesizer
C	Control
F	Frequency Counter
G	Generate/Monitor Control
K	Keyboard
M	Modulation
O	Oscilloscope
R	Receiver
V	Voltmeter/Distortion Analyzer
W	Wattmeter

21-17. The data field is comprised of five sub-fields as shown:



Data limits and accompanying units are given in table 21-3. The data field is optional or not allowed for certain commands.

21-18. **Data Sign.** The data sign is a single '+' or '-' character indicating the sign of the data value. The sign may be omitted for positive value data.

21-19. **Data Value.** The data value field is restricted to the numbers '0' through '9' and '.'. A maximum of five digits to the right and to the left of the decimal point are allowed. The decimal point can be omitted for integer values. If the value field is omitted, it is assumed to be zero.

21-20. **Exponent.** The presence of the "E" character in the exponent field indicates that the data value is to be multiplied by 10 raised to the power following the "E" character. If the "E" is omitted the exponent is assumed to be 10^0 or 1.

21-21. **Exponent Sign.** The exponent sign is a single + or - character and can be omitted for positive exponent values.

21-22. **Exponent Magnitude.** The exponent magnitude is a single character 0 through 9. If the exponent magnitude is omitted, it is assumed to be zero.

Table 21-3 Programming Commands					
Data	Units	Type	Function	Changes To	
				Display	Function Mode
AUDIO GENERATOR					
AA	0-999.9	Hz	D	Tone A Frequency	
AB	0-999.9	Hz	D	Tone B Frequency	
AD	0-999.9	Hz	D	F ₀ Frequency	
AD	0-777	—	D	DPL Code	
AF	X.XXXXX	—	D	S/B Tone Number	
AK	1-4	—	D	Tone Menu Select	
AT	XXXXXX	—	D	Telephone Number	
AV	XXXXXX	—	D	Select V Tone Number	
AS	1-8	—	D	Tone Sequence Select	
For AM - 1 (A/B)					
1 Tone					
2 Tr - Vse					
3 Var 1					
4 Var 2					
For AM - 2 (S-R)					
1 S Tone					
2 S Tone					
For AM - 3 (Modula Test)					
1 MTS					
2 MTS					
3 MTS					
For AM - 4 (Set V)					
1 VSE 1					
2 Modified ZVE 1					
3 OCOR (10ms)					
4 CCOR (100ms)					
5 SEA					
AW	0-9.99	SEC	D	A On User Sel. (AS - 3)	
AX	0-9.99	SEC	D	B Off User Sel. (AS - 3)	
AY	0-9.99	SEC	D	B On User Sel. (AS - 3)	
AZ	0-9.99	SEC	D	B Off User Sel. (AS - 3)	
CONTROL					
CD	0-12	—	C	Display Select	1
0 Gen-Mon Mtr					
1 Modulation					
2 Spect Analyzer					
3 Duplex Gen					
4 RF Mem					
5 Tone Mem					
6 Freq Counter					
7 DVM					
8 Fst Wattmeter					
9 IF					
10 Scope AC					
11 Scope DC					
12 Terminal					
CF	0-5	—	C	Function Select	1
0 FM					
1 CW					
2 AM					
3 SSB/DSBSC					
4 SWP 0-10 MHz					
5 SWP 0.01-1 MHz					
CG	—	—	C	Generate Mode	GEN
CM	—	—	C	Monitor Mode	MON
CP	—	—	C	Power Monitor Mode	PWR MON

Table 21-3 Programming Commands (Cont)					
Prefix	Data	Units	Type	Function	Changes To
					Display Function Mode
FREQUENCY COUNTER					
FC	0-35000	kHz	O	External freq count	2
GENERATE/MONITOR					
GF	0-999.9999	MHz	D	Generate/Monitor Frequency	
GL	-130.0 to -13.0	DBM	C	Generate RF Level	GEN
KEYBOARD					
K1	0-127	—	D	Display Up Key Data	
K2	0-127	—	D	Display Down Key Data	
K3	0-127	—	D	Function Up Key Data	
K4	0-127	—	D	Function Down Key Data	
K5	0-127	—	D	Mode Up Key Data	
K6	0-127	—	D	Mode Down Key Data	
MODULATION					
MB	—	—	C	Modulation Burst	
MC	—	—	C	Modulation Continuous	
MD	—	—	C	Modulation Off	
MM	0-5	—	C	Modulation Mode	
0 PL/DPL					
1 PL/DPL div					
2 Tone A					
3 Tone B					
4 Tone Sequence					
5 Tone Remote					
ME	0-99.9	kHz (FM)	C	External Mod Level	3 GEN
MK	0-99.9	kHz (FM) % (AM)	C	1 kHz Mod Level	3 GEN
MS	0-99.9	kHz (FM) % (AM)	C	Code Synthesizer Mod Level	— 3 GEN
OSCILLOSCOPE					
OH	0-6	—	C	Horizontal Sweep Select	
0 1 micro sec/div					
1 10 micro sec/div					
2 100 micro sec/div					
3 1 milli sec/div					
4 10 milli sec/div					
5 100 milli sec/div					
6 External					
OD	0-9.999	SEC	D	Trigger Delay	
OV	0-3	—	C	Vertical Gain Select	
0 10 V/div					
1 1 V/div					
2 0.1 V/div					
3 0.01 V/div					

Table 21-3 Programming Commands (Cont)					
Prefix	Data	Units	Type	Function	Changes To
					Display Function Mode
RECEIVER					
RH	—	—	C	High Image	
RL	—	—	C	Low Image	
RN	—	—	C	Narrow band	
RW	—	—	C	Wide band	
RA	0-13	10dB	C	Receive Mode Step Attenuator Setting	
0 0 dB					
1 10 dB					
2 10 dB					
3 10 dB					
4 10 dB					
RE	0-100	—	O	Receive Frequency error	4 MON
RP	0-1	—	O	Signal Presence Indication	MON
0 No signal					
1 Signal present					
R-	0-99.99	kHz	O	Minus Deviation	4 FM MON
R+	0-99.99	kHz	O	Plus Deviation	4 FM MON
RK	0-99.99	%	O	Minus % AM	4 AM MON
RJ	0-99.99	%	O	Plus % AM	4 AM MON
VOLTMETER					
VA	0-300	VOLTS	O	DVM AC	5
VD	0-300	VOLTS	O	DVM DC	5
VP	0-99.9	%	O	Distortion Reading	5
VS	0-40.0	dB	O	Sinad Reading	4 6 GEN
WATTMETER					
WE	1-9	—	D	Wattmeter element number	
1 2.5 W					
2 5 W					
3 10 W					
4 20 W					
5 50 W					
6 100 W					
7 250 W					
8 500 W					
9 1000 W					
WI	0-132.0	WATTS	O	Internal Wattmeter reading	4 PWR MON
WF	0-1000	WATTS	O	Forward External Wattmeter Reading	7
WH	0-1000	WATTS	O	Reverse External Wattmeter Reading	7
Notes					
1 Display is defined by the data					
2 External Frequency Counter Display					
3 FM if not AM					
4 Gen/Mon Mtr Display					
5 DVM Display					
6 FM if in DSBSC or SWEEP					
7 External Wattmeter Display					

21-23. The following are examples of correct data fields for the value 12.34:

0.1234 E+2	+0.1234 E2	1234 E-2	1234.E-2
+12.34	12.34E	+1234 E-2	12.34 E0

21-24. Command Strings. A command string consists of either a single command or multiple commands in succession with or without embedded spaces. A command string must be terminated with a carriage return and a line feed character.

21-25. Command Types. Each command is one of three basic types, control selects (C), data entry (D), and output requests (O). Type information for each command is listed in table 21-3.

21-26. Control Selects. Control select commands select front panel switch settings. Some of these commands do not require accompanying data, such as toggle switch commands.

21-27. Data Entry. Data entry commands replace manual entry of data through the keyboard. All of these commands require data in the data field.

21-28. Output Requests. Output request commands allow data that is normally displayed on the CRT to be transferred to the controller. Accompanying data is not required with output requests. The data limits and units listed in table 21-3 for these commands refer to the return data. Output request commands cause the analyzer to go to the proper display, function, and mode to acquire the designated reading. These states are listed in table 21-3. The measurement however, is not made until a trigger command 'T' has been sent from the controller. The trigger command causes the measurement to be made and the data held for transmission to the controller. Then when the controller addresses the analyzer as a talker the data is output to the controller. A reading can be retaken for any number of triggers without repeating the output request. The request is lost however, when any command changing the display, function, or mode is sent.

21-29. Trigger Command. The trigger command is the exception to the two character command prefix. This command is simply the letter 'T' usually sent immediately following the output request command. If no output request is pending, the trigger command is ignored.

21-30. Return Data. The data returned from the analyzer is formatted similar to the control data as shown.

DATA SIGN DATA VALUE EXPONENT SIGN EXPONENT MAGNITUDE

 / + / n / E / n

The data is always returned in this format with a single exception. Data for the "RP", signal present, command is returned as a single digit having a value of "0" or "1".

21-32. Data Value. The data value is 1 to 5 digits in length with leading zero suppression and no decimal point.

21-33. Exponent and Exponent Sign. The letter 'E' followed by a '-' character is always transmitted with return data.

21-34. Exponent Magnitude. The exponent magnitude is a single digit with a value from 0 to 9. The digit indicates the negative power of ten that is to be multiplied with the data value to obtain the units listed in table 21-3.

21-35. Programming Commands. Table 21-3 lists the programming commands available for the system analyzer. The table identifies the category and type of command, the data limits and units, the command function, and any display, function, or mode change that would occur.

21-36. Terminal Mode. When the command 'CD12' is used, the system terminal mode is enabled. The terminal mode allows the analyzer's CRT display and keyboard to perform as a limited function I/O terminal. Possible uses for the terminal mode would be to provide test instructions to a test operator at an auto test station.

21-37. Display Format. Once the 'CD12' command has been sent the terminal mode has been entered. All further ASCII valid characters sent from the controller will appear on the CRT display. The total display area on the CRT is 15 lines of 30 characters each. Character entry on the CRT is on the bottom line. Each line feed character causes the bottom line to move up one place. If more than 30 lines are entered, the top lines are lost off the top of the display. A list of valid ASCII characters for the display is provided in table 21-4. All invalid characters are ignored in the terminal mode.

21-38. Keyboard Entry. In the terminal mode the keyboards on the analyzer may be used to input data to the bus controller. The ten numeric keys and the left cursor key have predefined ASCII characters. The character corresponds to the number on the key for the numeric keys. For the left cursor key, carriage return and line feed characters are sent. The down cursor key causes a bus service request to be generated regardless of the operating mode. This key could be used to halt an automatic test sequence.

21-39. The remaining pushbuttons are defined, prior to entering the terminal mode, with the use of the keyboard control commands listed in table 21-3. Each key is assigned an ASCII character by following the Kn command prefix with the decimal equivalent of the binary ASCII code for that character. A list of valid ASCII characters and their binary and decimal equivalents are listed in table 21-4.

21-40. Data that is entered from the keyboard is stored in a 9 character buffer until addressed by the bus controller. If more than 9 keypresses occur before the controller accesses the analyzer, the excess inputs are lost. Once the controller has addressed the analyzer, the analyzer transmits the character data to the controller. The analyzer will continue to transmit, or hold up the bus handshake if no keys have been pressed, until the left cursor key is pressed. Thus every data string entering from the keyboard must terminate with the left cursor key. As the data is transmitted to the controller it is also entered onto the CRT display.

21-41. Terminal Mode Exit. An ASCII end of transmission character (EOT) sent from the controller will terminate the terminal mode. When the mode is terminated the analyzer returns to the Gen/Mon Mtr display, and is ready to accept new command inputs.

21-42. Error Messages. Error messages are generated by the analyzer to help the programmer troubleshoot his program. As control commands are received by the analyzer, they are decoded to determine the command sent. If the analyzer is unable to decode the command it generates an error message and ignores all succeeding commands. To clear the error condition the bus controller must address the analyzer as a talker so that the error message will be transferred to the controller.

21-8

21-43. The format of the error message is:

ERROR nn(CR)(LF)

The two digit number nn defines the error condition as listed in table 21-5. The carriage return (CR) and line feed (LF) characters are the termination sequence used by analyzer whenever it transmits information. All characters are ASCII coded.

Table 21-5. Error Messages

Error Code	Condition
00	Data requested without trigger
01	Invalid mnemonic prefix
02	One character mnemonic (not T)
03	Invalid mnemonic suffix
04	Exponent overflow
05	Data underflow
06	Data overflow
07	Data transmitted, not allowed
08	Invalid data
09	RF input power exceeded
10	Level or mod control error

21-44. To effectively utilize the error message capability of the analyzer it is necessary to address the unit as a talker after the transmission of each command string. The bus controller must then be programmed to recognize the error message and to decode the error number. A successful data transmission will send back an error code 00 when addressed as a talker. The controller should be programmed to ignore error 00 and to display any other error to the operator. Of course if a valid output command followed by the trigger command was sent, the talker address will result in the requested data being output to the controller.

21-45. Service Requests. There are only two conditions that will cause the analyzer to generate a service request (SRQ) on the bus. If a SRQ is generated it must be cleared by a serial poll of the analyzer. The serial poll is a bus command which results in a data byte being sent to the controller from the analyzer. The data byte indicates the cause of the SRQ. Table 21-6 lists the SRQ causes and the corresponding serial poll data.

Table 21-6. SRQ Data

Condition	Return Data		
	Binary	HEX	DEC
Depressing Cursor Down Key	01000001	41	65
RF load over Temperature	01000010	42	66

21-10

Table 21-4. Terminal Mode ASCII Characters Printable Characters

ASCII Char	Equivalent			ASCII Char	Equivalent		
	Binary	Hex	Dec		Binary	Hex	Dec
@	00100000	20	32	@	01000000	40	64
A	00100001	21	33	A	01000001	41	65
B	00100010	22	34	B	01000010	42	66
C	00100011	23	35	C	01000011	43	67
D	00100100	24	36	D	01000100	44	68
E	00100101	25	37	E	01000101	45	69
F	00100110	26	38	F	01000110	46	70
G	00100111	27	39	G	01000111	47	71
H	00101000	28	40	H	01001000	48	72
I	00101001	29	41	I	01001001	49	73
J	00101010	2A	42	J	01001010	4A	74
K	00101011	2B	43	K	01001011	4B	75
L	00101100	2C	44	L	01001100	4C	76
M	00101101	2D	45	M	01001101	4D	77
N	00101110	2E	46	N	01001110	4E	78
O	00101111	2F	47	O	01001111	4F	79
P	00110000	30	48	P	01010000	50	80
Q	00110001	31	49	Q	01010001	51	81
R	00110010	32	50	R	01010010	52	82
S	00110011	33	51	S	01010011	53	83
T	00110100	34	52	T	01010100	54	84
U	00110101	35	53	U	01010101	55	85
V	00110110	36	54	V	01010110	56	86
W	00110111	37	55	W	01010111	57	87
X	00111000	38	56	X	01011000	58	88
Y	00111001	39	57	Y	01011001	59	89
Z	00111010	3A	58	Z	01011010	5A	90
[00111011	3B	59	[01011011	5B	91
\	00111100	3C	60	\	01011100	5C	92
]	00111101	3D	61]	01011101	5D	93
^	00111110	3E	62	^	01011110	5E	94
_	00111111	3F	63	_	01011111	5F	95

NON-PRINTING CHARACTERS			
Equivalent			
ASCII Char	Binary	Hex	Dec
EOT*	00000100	04	4
BELL	00000111	07	7
BSP	00001000	08	8
LF	00001010	0A	10
CR	00001101	0D	13
*causes exit from terminal mode			

21-9

21-46. Programming Considerations. The flexibility of the IEEE-488 option is reflected in the number of programming commands. To use these effectively and efficiently, certain programming practices should be followed. The following paragraphs present the major considerations for effective programming.

21-47. General. Overall, programming the analyzer involves the same steps as are involved when using it manually. A program can be fairly easily obtained by first performing the desired test sequence manually noting each time a setting is changed and a reading made. The program is then simply a duplication of the manual steps with control commands substituted.

21-48. Generate Mode. For accurate level control it is best to specify the generate frequency prior to the RF output level. For example, the command string: CGGFIOOGLS sets the generate mode, a frequency of 100 MHz and an output level of -4 dBm.

21-49. Code Synthesizer. Before enabling the output of the code synthesizer with an MS, ME, or MK command, all the necessary parameters must first be defined. Table 21-7 lists the modes and their controlled parameters that need to be defined. It should be noted that these parameters do not need to be defined each time a mode is selected, only when they are to be changed for that mode.

21-50. Always select a tone mode before selecting a tone sequence ie: command an AM before AS as in AM4 A85 for 'Sel V, EEA' sequence.

21-51. Both sequence 3 and sequence 4 in tone mode 1 (A/B) are user selectable. This means that the A/B User's Sequence from Table 21-7 could also read A/B User Sequence AM1AS4X1A1Y1AZ1MM2MS3MM4.

21-52. When selecting AM3 (mobile telephone sequence) it is not possible to modify the frequency of the tones with the AA or AB commands. The frequency of the tone can only be changed through manual entry. When the analyzer is powered up, the frequency of the tone is whatever was last entered manually and retained in the non-volatile memory.

21-53. To set up a code synthesizer level (AM depth or FM deviation) with the MS command it is necessary to first select tone A or tone B (MM2 or MM3). Therefore, always request MM2 or MM3 before setting up a level with the MS command. If a tone sequence is desired, follow the MS command with an MM4 or MM5.

Table 21-7. Code Synthesizer Programming Considerations

Output	Command String	Effect
DPL Code	CF0AD131MM0MS3	FM, DPL Code 131, 3 kHz FM
DPL Inverted Code	CFAD313MM1MS5	FM, DPL Code 313, 5 kHz FM
PL Code	CF2AP60 5MM3S0	AM, PL60 5 Hz, 30% AM
Tone A	CFAAZ30MM2MS3	FM, 2000 Hz, 3 kHz FM
Tone B	CFAB2000MM3S3	FM, 2000 Hz, 3 kHz FM
Tone Remote	CFAA1 5E3AB300AM1MM2MS3MM5	FM, Mode 1, A=1500 Hz, B=300 Hz, 3 kHz FM
A/B Standard Sequence	CFAM1AS1AA1E3ABZ30MM2MS3MM5	FM, Mode 1, seq. 1, A=1 kHz, B=2 kHz, 3 kHz FM
A/B User Sequence	AM1, AS3AX1AY1AZ1MM2MS3MM4	1 sec. on/off times, 3 kHz FM
B Tone A/B Sequence	AM2AS2AF1 23456MM2MS3MM4	Preamble & 6 tones, 3 kHz FM
Mobile Tel. MTS seq	AM3AS2AT820X3B9MM2MS3MM4	Preamble & 7 digits, 5 kHz FM
CD1H 100MS Sel V seq	AM4AS4AV9676MM3MS5MM4	5 tones, 5 kHz FM

21-11

21-54 Modulation. The system analyzer is capable of modulating with three simultaneous sources. The commands ME, MK, and MS only affect their individual portion of the total output. Thus to avoid inadvertently having an unwanted modulation source enabled it is recommended that all three source values be defined together. For example:

CFMKMSME20

selects the FM mode, disables the 1 kHz and code synthesizer modulation, and set 20 kHz deviation from the external input. The external input must be applied to the analyzer prior to sending this command.

21-55. For the generate AM mode the frequency and output level must be defined prior to selecting the modulation level. The following command string is of the proper sequence to obtain 30% AM at 100 Mhz with a level of -100 dBm:

CGGF100GL100MEMSMK30

21-56. The bandwidth control commands, RN and RW, range the generate FM modulator sensitivity. For greater resolution and faster set up time for deviations less than 20 kHz use the narrowband RN command. Above 20 kHz deviation the wideband RW command must be used.

21-57. Either upper or lower case letters can be used in programming the analyzer. In the terminal mode, lower case letters will appear as upper case letters on the CRT screen.

21-58. Measurements. To obtain correct monitor mode data it is necessary to first set the frequency, bandwidth, and image prior to making the reading. Thus, it is a good practice to always place the request for a reading as the last command in the string. For example the command string:

CMRNHRGF95 SRET

selects the monitor mode, narrowband, high image, and 95.5 MHz center frequency. The RET command asks for a frequency error reading and triggers the analyzer so that the reading will be made.

21-59. R2002C Analyzer Configuration

The R2002C analyzer differs in configuration from the standard R2001C in the following manner:

A11 Module: The manual attenuator AT1 is replaced with a programmable version. A new ribbon cable assembly connected to the A8 module provides control signals for the attenuator.

A9 Module: Additional memory for the IEEE program is added by adding U8.

Front Panel Assembly A14: Rotary switch S19 is added for control of the HF Input/Output level.

Module A8 is added to the analyzer (see Section 14 for details). Ribbon cable assembly is added from the A8 module to the rear panel of the analyzer to provide I/O signals.

For conversion of R2001C to R2002C, contact your local area test equipment sales office.

Addendum to Section 21 68-81069A99-0

The items that require clarification relate to the code synthesizer functions and modify paragraphs 21-48 thru 21-50 as follows:

1. Always select a tone mode before selecting a tone sequence, i.e: select an AM before selecting AS (table 21-7, last five examples are in error)
2. Use AS3 or AS4 to select A/B delay (AW, AX, AY, AZ). AS5 is no longer available (table 21-7, last example is in error).
3. To set up a code synthesizer level (AM depth or FM deviation) with the MS command it is necessary to select tone A or tone B first (M2 or M3). Therefore, always request M2 or M3 before setting up a level with the MS command. If a tone sequence is desired, follow the MS command with an M24 or M25.
4. When selecting AM3 (mobile telephone sequence) it is not possible to modify the frequency of the tones with the AA or AB commands. The frequency of the tone can only be changed through manual entry. When the analyzer is powered up, the frequency of the tone is whatever was last entered manually and retained in the non-volatile memory.
5. The analyzer now recognizes lower case letters in terminal mode and in commands.
6. The following chart is enclosed to clarify the various functions available with the new code synthesizer:

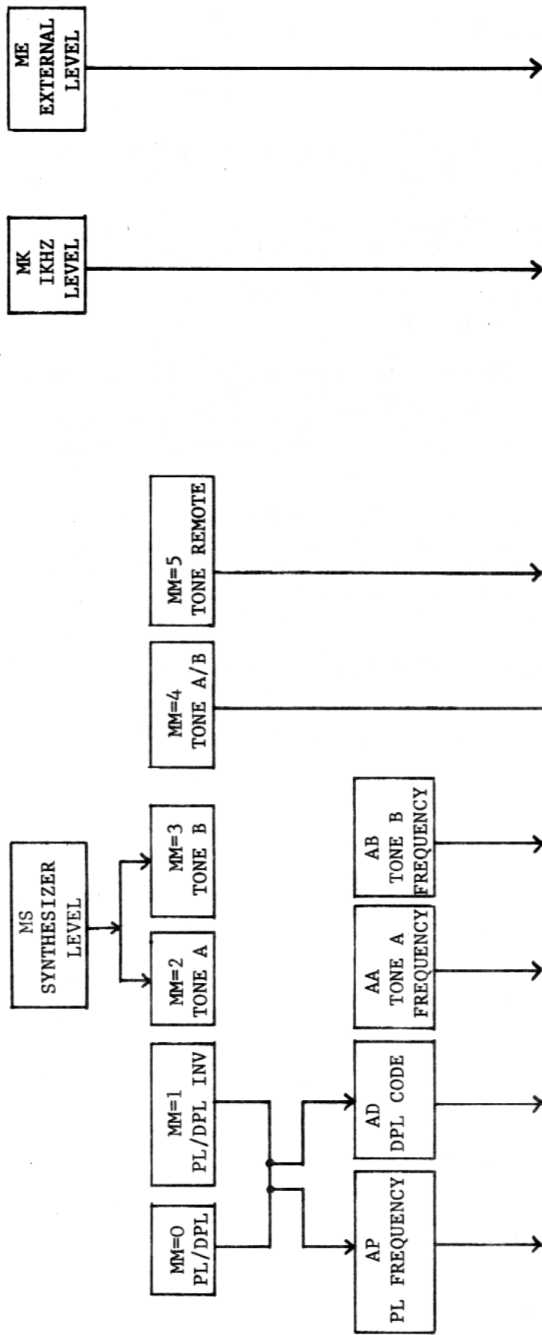

21-14

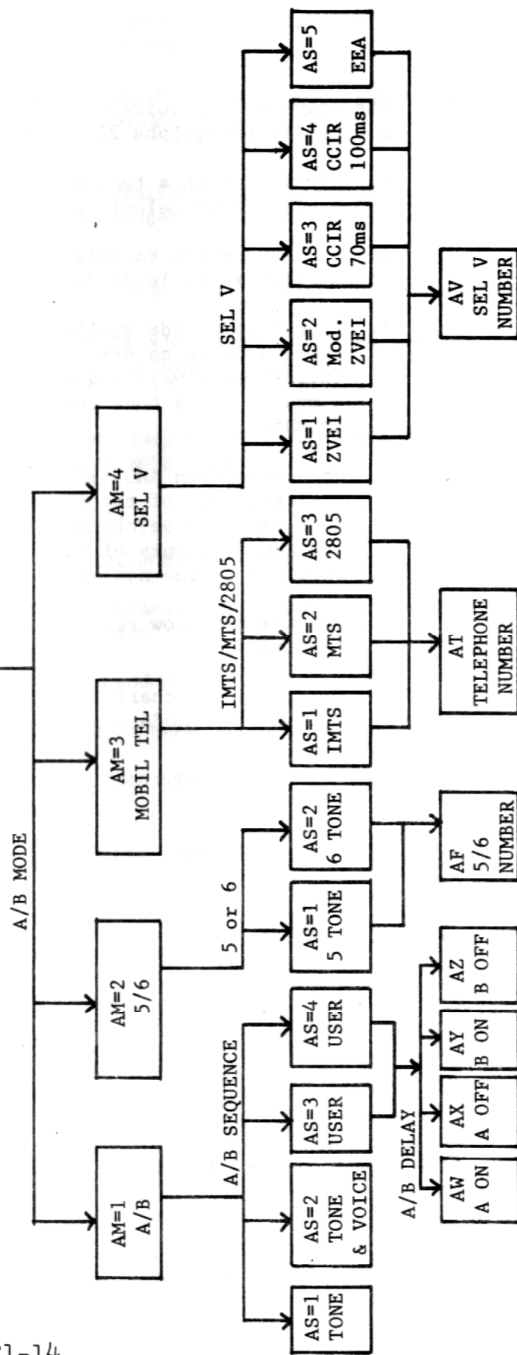

COMMUNICATIONS SYSTEM ANALYZER

68P81069A99-0

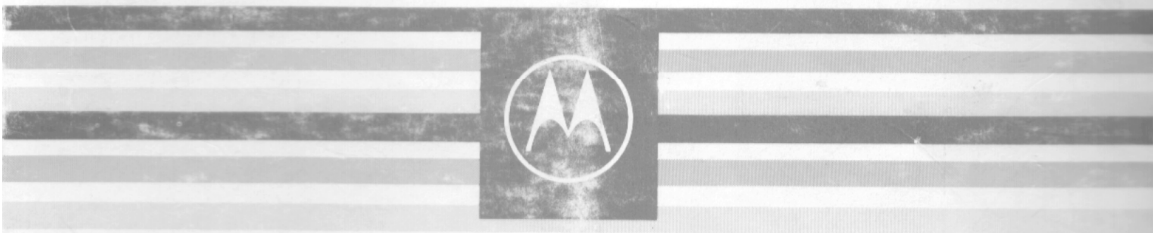



1. DESCRIPTION

The RTP-1002A is a battery pack and charger designed to be mounted to the back of the R-2001 Communications System Analyzer. The unit contains battery capacity to operate the R-2001 for approximately one hour. A constant current charging system is capable of recharging the batteries in 16 hours.

2. OPERATION

2.1 The RTP-1002A Battery Pack is automatically engaged when no ac power is present, and the power switch is either in the ON or STANDBY positions. When ac power is applied, the R-2001 automatically switches the RTP-1002A Battery Pack out of the circuit and draws its power from the ac power source.

2.2 When the power switch is in the OFF or STANDBY position and ac power is applied to the R-2001, the RTP-1002A Battery Pack draws dc current from the R-2001 to activate the charging circuit. The charging circuit delivers approximately 750 mA of current until the battery voltage reaches 14 volts. As the

battery voltage reaches 14 volts, the current drops to approximately 25 mA and the high-charge indicator LED extinguishes.

2.3 When the R-2001 systems analyzer is used with the RTP-1002A Battery Pack, it is recommended to keep the power switch in the STANDBY position whenever possible. This extends the time the battery is able to operate the R-2001 Communications System Analyzer. The low trickle charge rate enables the batteries to be left on charge indefinitely without damage due to overcharging.

CAUTION

Do NOT permit battery discharge below 10.4 V dc as indicated on CRT in DVM display mode; immediately turn unit "OFF". Allowing battery discharge below this level may result in permanent damage to the battery. The R-2001 should be plugged into ac power (117/234 V ac) with the power switch in "OFF" or "STANDBY" position to recharge the batteries.

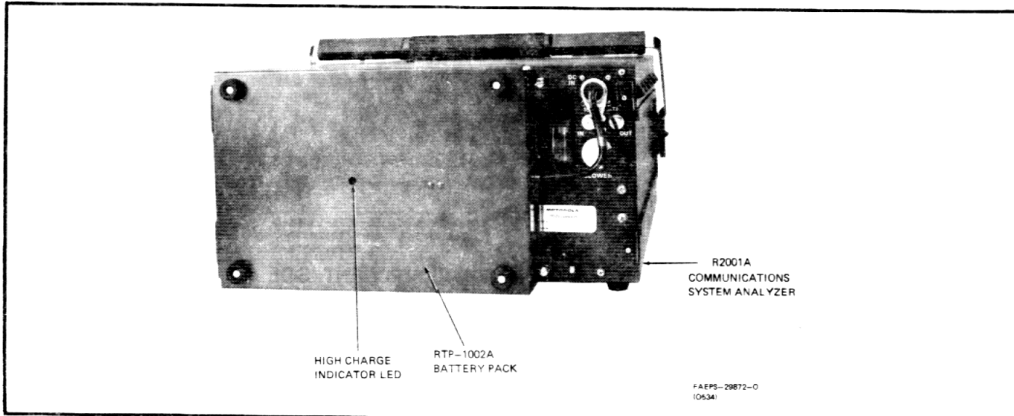

RTP-1002A Battery Pack Mounting Detail

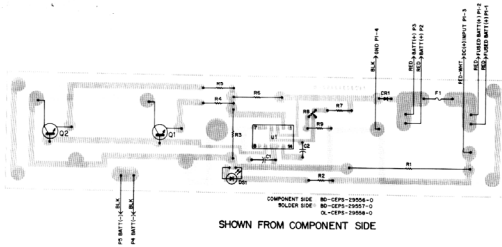
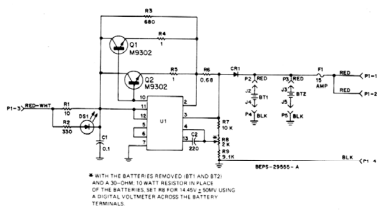

RTP-1002A Battery Pack
Schematic Diagram, Circuit Board Detail,
Parts Location Detail, and Parts List
Motorola No. PEP-29554-A
(Sheet 1 of 2)

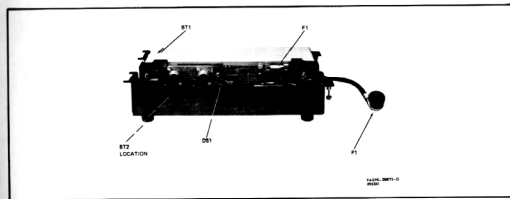

RTP-1002A Battery Pack Parts Location Detail

parts list

REFERENCE SYMBOL	MOTOROLA PART NO.	DESCRIPTION	PL. 5816.4
BT1, 2	60-8034348	Battery, 12 V.	
C1	8-5096118	capacitor, fixed, 1 uF ± 10%, 250 V	
C2	21-8396610	220 pF ± 20%, 500 V	
CR1	48-8292501	diode (see note)	
DS1	48-8207610	light emitting diode, 1.5 CD	
F1	65-804906	15A slow blow	
G1, 2	48-869302	transformer (see note) NPN type M8302	
R1	17-8036840	resistor, fixed, 10 Ω, 10 W	
R2	6-124221	200 Ω	
R3	6-105241	100 Ω	
R4, 5	6-125810	5 ± 5%, 1/2 W	
R6	17-8036841	50 Ω ± 4%, 1/2 W	
R7	6-124473	10k ± 5%	
R8	6-8036470	resistor, CA, ± 20%, 1/2 W	
R9	6-124472	8.7k ± 5%	
U1	51-8034349	integrated circuit (see note) MCT723CL	

REFERENCE SYMBOL	MOTOROLA PART NO.	DESCRIPTION	non-referenced items
	1-8034471	BATTERY CASE includes:	
	27-8035441	CASE, battery	
	3-8034489	SCREW, captive, 6-32 x 2.102", 2 used	
	41-8034483	SPRING, coil	
	15-8034432	COVER, battery case	
	1-8034472	CIRCUIT BOARD ASSEMBLY includes:	
	42-8292501	CLIP, top-mount, 2 used	
	42-8292502	CLIP, bottom-mount, 4 used	
	1-8034473	LEAD ASSEMBLY, battery terminals, WIRE, No. 18 stranded, #12" used	
	26-80116	CONTACT, resectable	
	1-8034474	LEAD ASSEMBLY, battery blocks includes:	
	26-80116	CONTACT, resectable	
	26-80116	WIRE, No. 18 stranded, #12" used	
	4-7666	WASHER, lock, No. 4 external tooth, 4 used	
	64-8034244	PLATE, insulator	
	1-8034475	CABLE ASSEMBLY, includes:	
	15-1081408	HOUSING, connector, 4 pin	
	8-8241101	CONTACT, resectable, 4 used	
	42-8292503	CLAMP, cable	
	2-7666	NUT, flat, 8-32, 4 used	
	4-7666	WASHER, lock, No. 8 external tooth, 4 used	
	14-8034491	INSULATOR BOARD	
	15-8292501	FOOT, rubber, 4 used	
	2-8034446	SCREW, machine, 8-32 x 1/2", 4 used	
	3-138774	SCREW, machine, 4-40 x 1/4", 3 used	
	3-138461	SCREW, machine, 8-32 x 1/8", 2 used	
	4-7667	WASHER, lock, No. 4 external tooth, 5 used	
	42-8292505	CLAMP	

note: For optimum performance, replacement diodes, transformers and integrated circuits must be ordered by Motorola part number.

RTP-1002A Battery Pack
Schematic Diagram, Circuit Board Detail,
Parts Location Detail, and Parts List
Motorola No. PEP-29554-A
(Sheet 2 of 2)