

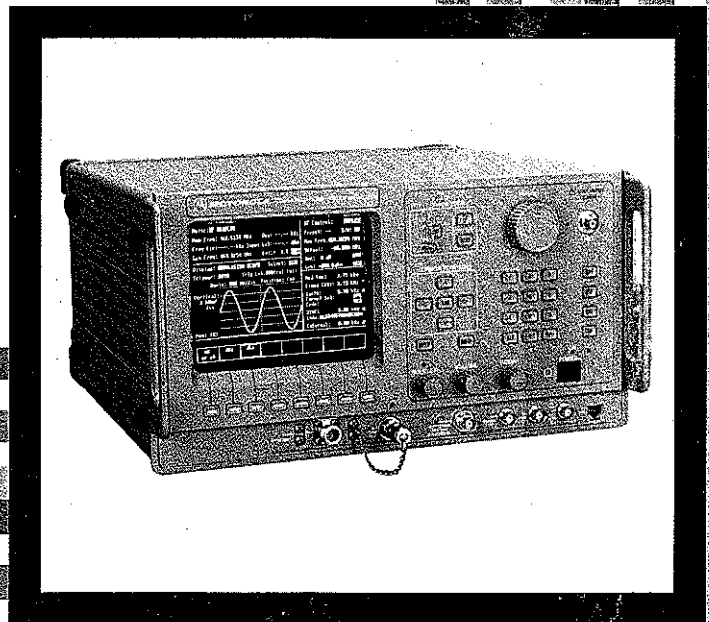

MOTOROLA

test equipment

**Communications
System Analyzer
OPERATOR'S MANUAL**



R-2550



R-2550
Communications
System Analyzer
OPERATOR'S MANUAL

Motorola Test Equipment Products
1313 E. Algonquin Rd.
Schaumburg, IL 60196

©Motorola, Inc. 1993
All Rights Reserved
Printed in U.S.A.

68P80309E54

Table of Contents

<u>Topic</u>	<u>Page</u>
LIMITED WARRANTY	iv
COMPUTER SOFTWARE COPYRIGHTS	v
SERVICE LOCATIONS	vi
TEST EQUIPMENT SERVICE REQUEST FORM	vii

Section I INTRODUCTION

1-1	SCOPE OF MANUAL	1
1-2	WARNINGS AND CAUTIONS	1
1-3	SERVICE	1
1-4	REPLACEMENT PARTS ORDERS	1
1-5	INSTALLATION	1
	1-5.1 Packing	1
	1-5.2 Initial Set-up	1
	1-5.3 Battery Pack Operation	2
	1-5.4 Battery Pack Installation	4

Section II DESCRIPTION

2-1	DESCRIPTION	5
2-2	OPERATOR CONTROLS	5
	2-2.1 Keys & Indicators	5
	2-2.2 Knobs	8
	2-2.3 CRT	8
	2-2.4 Connectors	9
2-3	BOTTOM CONTROLS	10

Table of Contents (CONT)

Topic

Page

Section III OPERATING INSTRUCTIONS

3-1	GENERAL	11
3-2	BASIC OPERATION	11
	3-2.1 Expanded Display	13
3-3	HELP	13
3-4	WARNINGS	15
3-5	PRIMARY OPERATING MODES	16
	3-5.1 MONITOR Mode	16
	3-5.2 GENERATE Mode	18
	3-5.3 DUPLEX Mode	20
	3-5.4 TRACKING GENERATOR Mode (Option)	22
3-6	AUDIO/MODULATION SYNTHESIZER	24
	3-6.1 Fixed 1 kHz	24
	3-6.2 Synth	24
	3-6.3 DTMF	26
	3-6.4 External	26
3-7	METER AND DISPLAY	28
	3-7.1 Meter	28
	3-7.2 Display	33
3-8	OTHER FUNCTIONS	37
	3-8.1 Audio Monitor	37
	3-8.2 Remote Operation	37
	3-8.3 Calibration	37
	3-8.4 Special Functions Menu	37
	3-8.5 Memory Screens	39

Table of Contents (CONT)

<u>Topic</u>		<u>Page</u>
	Section IV	
	APPLICATIONS	
4-1	BASIC FM TRANSMITTER TESTING	41
4-1.1	Basic FM Transmitter Testing Setup	42
4-1.2	Transmit Power, Frequency, and Frequency Deviation Measurements	42
4-1.3	Modulation Measurements	43
4-1.4	Off-The-Air Measurements	45
4-2	BASIC FM RECEIVER TESTING	46
4-2.1	Basic FM Receiver Testing Setup	47
4-2.2	Receiver Distortion Measurement	48
4-2.3	SINAD Measurement	48
4-2.4	Modulation Acceptance Bandwidth	49
4-2.5	Receiver Sensitivity Testing (20 dB Quieting)	49
4-2.6	Squelch Sensitivity Test	50

APPENDIXES

Appendix A		
	LIST OF ABBREVIATIONS	53
Appendix B		
	TONE AND CODE SPECIFICATIONS	55
Appendix C		
	SAFE HANDLING OF CMOS INTEGRATED CIRCUIT DEVICES	59
Appendix D		
	EXTERNAL PORT PIN ASSIGNMENTS	61

MOTOROLA TEST EQUIPMENT PRODUCTS

LIMITED WARRANTY

(EXCLUDES EXPORT SHIPMENTS)

Motorola Test Equipment Products (herein the "product") that are manufactured or distributed by Motorola Communications Group Parts Department are warranted by Motorola for a period of one (1) year from date of shipment against defects in material and workmanship.

This express warranty is extended to the original purchaser only. In the event of a defect, malfunction, or failure during the period of warranty, Motorola, at its option, will either repair, or replace the product providing Motorola receives written notice specifying the nature of the defect during the period of warranty, and the defective product is returned to Motorola at 1313 East Algonquin Road, Schaumburg, IL 60196 transportation prepaid. Proof of purchase and evidence of date of shipment (packing list or invoice) must accompany the return of the defective product. Transportation charges for the return of the product to Purchaser shall be prepaid by Motorola.

This warranty is void, as determined in the reasonable judgement of Motorola, if:

- (a) The product has not been operated in accordance with the procedures described in the operating instruction;
- (b) The seals on non-user serviceable components or modules are broken;
- (c) The product has been subject to misuse, abuse, damage, accident, negligence, repair or alteration.

In no event shall Motorola be liable for any special, incidental, or consequential damages.

In the event Motorola elects to repair a defective product by replacing a module or subassembly, Motorola, at its option, may replace such defective module or subassembly with a new or reconditioned replacement module or subassembly. Only the unexpired warranty of the warranty product will remain in force on the replacement module or subassembly. **EXCEPT AS SPECIFICALLY SET FORTH HEREIN, ALL WARRANTIES EXPRESS OR IMPLIED, INCLUDING ANY IMPLIED WARRANTY OF FITNESS FOR A PARTICULAR PURPOSE OR MERCHANTABILITY, ARE EXCLUDED.**

COMPUTER SOFTWARE COPYRIGHTS

The Motorola products described in this instruction manual include copyrighted Motorola computer programs stored in semiconductor memories or other media. Laws in the United States and other countries preserve for Motorola certain exclusive rights for copyrighted computer programs, including the exclusive right to copy or reproduce in any form the copyrighted computer program. Accordingly, any copyrighted Motorola computer programs contained in the Motorola products described in this instruction manual may not be copied or reproduced in any manner without the express written permission of Motorola. Furthermore, the purchase of Motorola products shall not be deemed to grant either directly or by implication, estoppel, or otherwise, any license under the copyrights, patents or patent applications of Motorola, except for the normal non-exclusive, royalty free license to use that arises by operation of law in the sale of a product.

This product contains silicon software designed by Ready Systems Corp. ©1989 Ready Systems Corp. All rights reserved. Unpublished-rights reserved under the copyright laws of the United States.

RESTRICTED RIGHTS LEGEND

Use, duplication or disclosure by the Government is subject to restrictions as set forth in subparagraph (c)(1)(ii) of the Rights in Technical Data & Computer Software clause at DFARS 252.227-7013.

READY SYSTEMS, 470 POTRERO AVENUE, SUNNYVALE, CA 94086

Specifications subject to change without notice.

Motorola, Private-Line, and Digital Private-Line are trademarks of Motorola, Inc.

Vertex, RSC, Ready Systems Corp. are trademarks of Ready Systems Corporation.

Printed in U.S.A. ©1990 Motorola Inc.

SERVICE LOCATIONS

General Offices:

MOTOROLA
Communications Div Parts Dept.
1313 E. Algoquin Rd.
Schaumburg, Illinois 60196
Ordering: (800) 422-4210

Test Equipment Service Centers: 800-323-6967

UNITED STATES
Motorola Inc., Test Equipment Service Depot
1308 Plum Grove Road
Schaumburg, IL 60173
Phone: (708) 576-7025
FAX: (708) 576-8813

AUSTRALIA
Motorola Pyt, Ltd.
666 Wellington Rd.
Mulgrave, 3170
Victoria
Phone: 61-3-566-7610
FAX: 61-3-561-3809

CANADA
Motorola Canada Ltd.
System and Aftermarket Products
3125 E. Steeles Ave.
North York, Ontario M2H 2H6
Phone: 416-499-1441 Ext. 3051

FRANCE
Motorola Storno
69 Rue Andre Karman
93300 Aubervilliers
Phone : 33-1-4843 9244

FEDERAL REPUBLIC OF GERMANY

Motorola GmbH
Georg Ohm Str. 2
D6208 Taunusstein 4 (Neuhof)
Phone: 49-6128-702178
FAX: 6128-73538

ISRAEL

Motorola
16, Kremenetski Str.
Tel-Aviv 67 889
Phone: 972-3-338 590
FAX: 972-3-562 4925

ITALY

Motorola SpA
Via Galvani 1/2
20090 Trezzano Sul Naviglio (MI)
Phone: 39-02-48401458

JAPAN

Nippon Motorola Ltd.
2-1-3 Arakawa-Ku
Tokyo 106
Phone: 81-3-802-9188
FAX: 81-3-802-9170
Cable: MOTOROLA
Telex: 7812424897

REPUBLIC OF SINGAPORE

Motorola Singapore Pte. Ltd.
Blk 1302, Lorong 1 Toa Payoh #01-03/04
Siong Hoe Industrial Bldg.
Singapore 1231
Phone: 3530311
FAX: 3539152

UNITED KINGDOM

Motorola Ltd.
Viabes Industrial Extate
Basingstoke, Hampshire RG224PD
Phone: 0256-58211

MOTOROLA, INC.
COUMMUNICATIONS SECTOR
TEST EQUIPMENT SERVICE DEPOT
 1308 Plum Grove Rd.
 Schaumburg, IL 60173

TEST EQUIPMENT SERVICE REQUEST FORM
 This completed form must accompany equipment return for service.

CUSTOMER'S PURCHASE ORDER NUMBER	DATE
MODEL NUMBER	SERIAL NUMBER
DESCRIPTION OF PROBLEM:	
REQUESTED SERVICE	
SHIP TO ADDRESS	
SHIP VIA:	

Providing the information below will reduce the turnaround time on you Test Equipment Service.

MOTOROLA CUSTOMER NUMBER	BILL TAG	SHIP TAG	INTERNATIONAL MOTOROLA ACCOUNT NO.
--------------------------	----------	----------	------------------------------------

SIGNED: _____

Section 1

INTRODUCTION

1-1 SCOPE OF MANUAL

This manual contains information for using the R-2550 Communications System Analyzer. The Analyzer incorporates many devices and functions, permitting a technician to completely monitor and service radio communications equipment in the shop and in the field.

1-2 WARNINGS AND CAUTIONS

You should observe several precautions when handling this equipment.

WARNING

This unit is designed to be operated with a ground connection to the chassis via a three-wire power connection. If the unit is not properly grounded while operating from an AC power source, the voltage potential between it and ground may cause an electrical shock.

CAUTION

This equipment contains parts that are subject to damage by static electricity. While there is normally no need for operator access to any internal components, take proper precautions in handling should the need arise. See Appendix C for safe handling procedures.

1-3 SERVICE

Motorola Test Equipment Service Centers service all test equipment supplied by the Motorola Communications Sector. The Center maintains a stock of original equipment replacements parts and a complete library of service information for all Motorola test equipment. A service request form along with a list of worldwide service locations is found at the front of the manual.

1-4 REPLACEMENT PARTS ORDERS

Send orders for replacement parts to the nearest Motorola Test Equipment Service Center. Be sure to include the complete identification number located on the equipment. Also direct inquiries to the Test Equipment Service Center, including requests for part number identification and test equipment calibration or repair.

1-5 INSTALLATION

1-5.1 Packing

Foam pieces protect the R-2550 Analyzer, which is packed inside a carton. Save the packing container and materials for future use.

1-5.2 Initial Set-up

1. Place the Analyzer on a workbench in the shop or mobile repair unit.
2. Lower the bail underneath to raise the Analyzer for easier viewing.
3. Remove the front cover by pressing in the spring loaded mechanism

which snaps into the right front handle of the unit.

4. Take the power cord that is stored in the cover. Attach the cord's female connector to the appropriate connector on the Analyzer's rear panel. Connect the other end of the cord to the power source. For AC, use a grounded 3-wire 100-130 VAC or 200-260 VAC power source.
5. Set the two-position LINE switch (bottom of unit) to either the 110 or 220 position, as applicable. The factory initially sets the LINE switch for 110 VAC. A 3A fuse for 110 VAC operation and a 10A fuse for DC operation are installed at the factory. Change as indicated for 220 VAC operation.

<u>OPERATION</u>	<u>FUSE</u>	<u>PART NUMBER</u>
110 VAC	3A	65-20404
12 VDC	10A	65-10266
220 VAC	1.5A	65-890033

6. Remove accessories from the cover as needed.
7. Insert the whip antenna into the ANT port, located to the right of the tuning knob on the front panel.
8. Press the power switch ON. The Analyzer is now ready for use. Before operating the Analyzer, review the operating procedures described in this manual.

CAUTION

When installing the Analyzer in a vehicle, fuse the DC supply line close to the vehicle's battery. The DC-10A fuse (located on the Analyzer's rear panel) protects the Analyzer against overload but does not protect the vehicle.

1-5.3 Battery Pack Operation

The optional battery pack (RPN-4000A) is designed to conveniently mount to the back of the R-2550. Containing an internal battery charger, the battery pack is automatically recharged whenever connected direct to an AC receptacle. Battery charging is independent of the main R-2550 equipment.

NOTE

The battery pack has an internal switch allowing the user to switch operation of the battery pack to 115 VAC or 220 VAC. Before attempting to plug the battery pack into the ac line for charging, ensure this switch is set to the correct position for your line voltage. This switch is accessible by removing six screws attaching the cover to battery pack chassis as shown in figure 1-1.

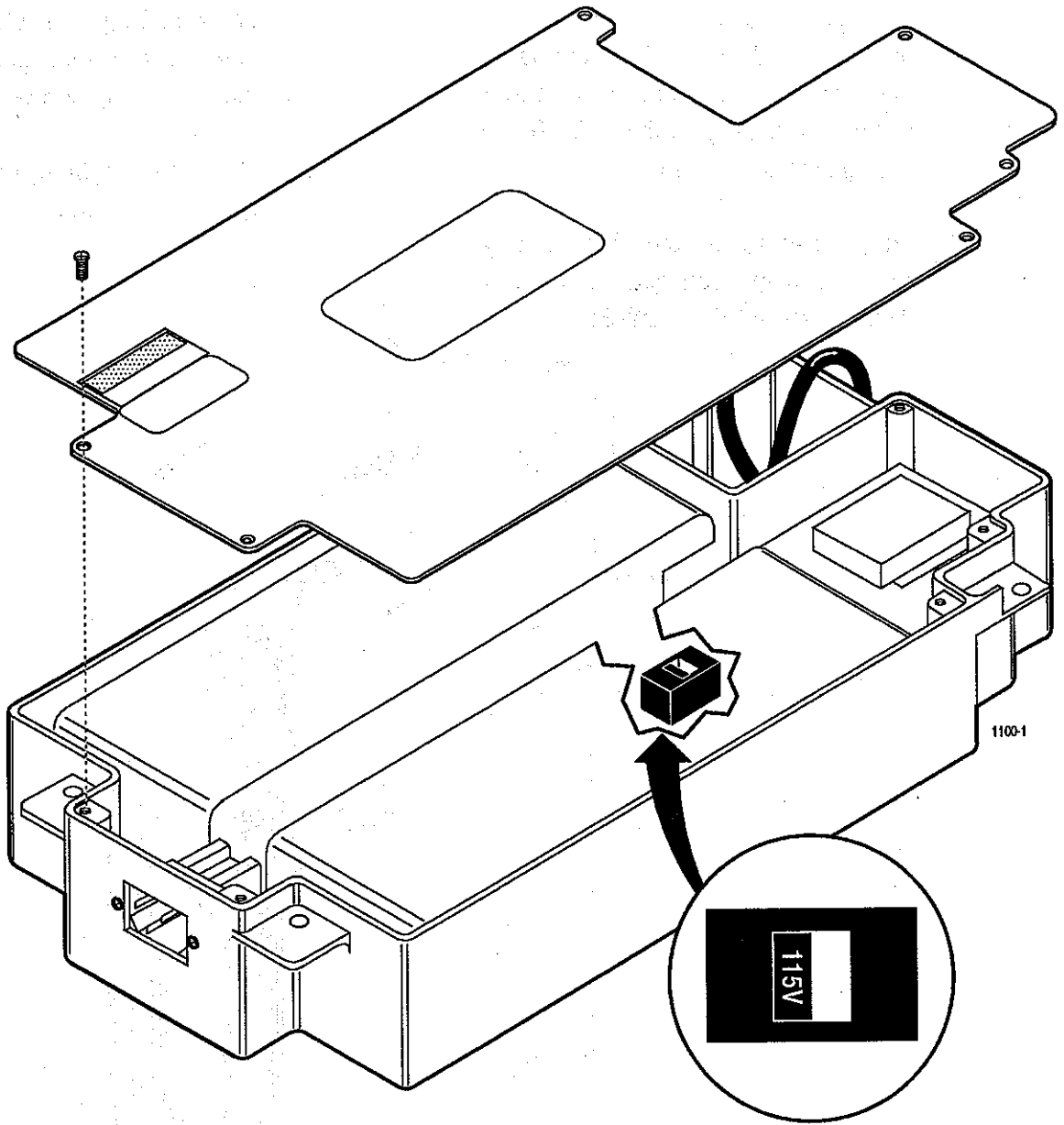

Figure 1-1. 110 VAC/220 VAC Selection Switch

1-5.4 Battery Pack Installation

1. Set the R-2550 in an inverted vertical position on a table with the back of the unit facing upward.
2. Lay battery pack on the back surface of the R-2550 such that the cut out in the battery, will match the locations of the power plug on the R-2550. Do not engage the attachment screw yet.
3. Plug four-pin connector from battery pack to four-pin connector on back of R-2550 labeled DC POWER.
4. Plug AC cord from battery pack to AC power plug on back of R-2550 unit.
5. Dress cabling into retaining area and slide battery into position to align with mounting screws
6. Align and tighten the four slotted mounting screws.

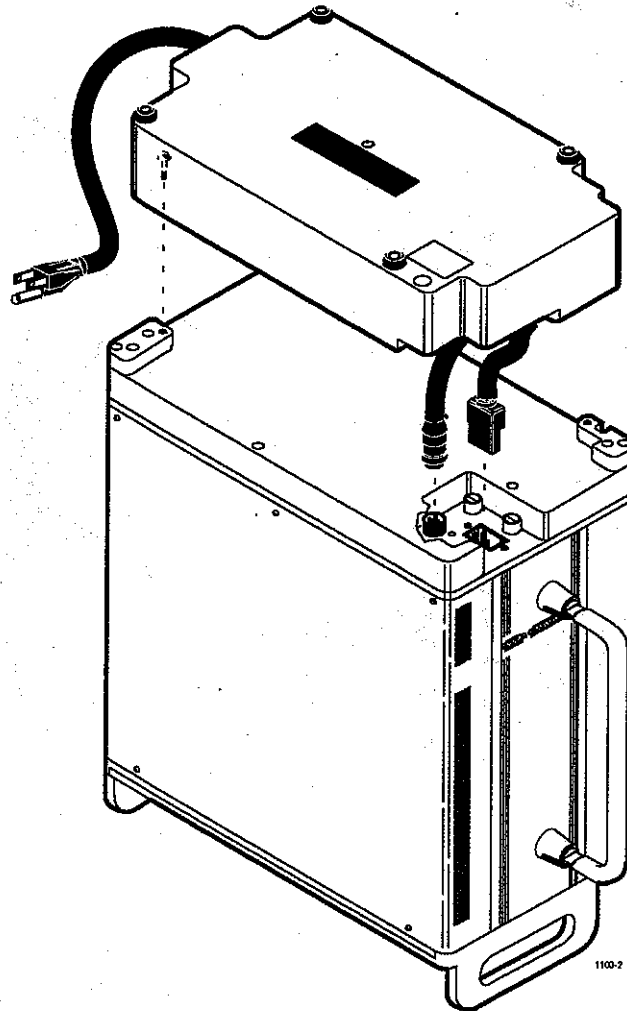

Figure 1-2. Battery Pack Installation

Section 2

DESCRIPTION

2-1 DESCRIPTION

The R-2550 Communication System Analyzer is a portable test instrument designed to monitor and service radio communications equipment over the frequency range of 400 Hz to 999.9999 MHz. Figures 2-1 and 2-2 show the Analyzer's controls, indicators, and connectors, and lists their functions. The Analyzer generates signals, measures modulation and frequency, and performs a variety of tests normally associated with the following devices:

- RF Signal Generator
- Sensitive Measurement Receiver
- Spectrum Analyzer
- Duplex Offset Generator
- Oscilloscope
- Period Counter
- AC/DC Voltmeter
- RF Wattmeter
- Signaling Encoder/Decoder
- Signal Strength Meter
- SINAD Meter
- Distortion Analyzer

2-2 OPERATOR CONTROLS

2-2.1 Keys & Indicators

Power Switch

Press ON to energize all circuitry. The unit automatically selects AC power if line power is available. Otherwise, the

unit looks for a DC source. Switching is automatic upon cycling of the POWER switch.

ON LED

Illuminates when power switch is pressed ON.

DC LED

Illuminates when equipment uses DC power.

Cursor Zone Keys (RF, AUD, & DISP)

Determines the zone (third of CRT screen) that the cursor will be active in. When changing zones, the cursor moves to the same cursor location occupied the previous time it was in that zone.

Cursor Position Keys (Up, Down, Left, Right, TAB)

The five cursor movement keys are used to move the cursor to the left, right, up, down, or tab.

HELP Key

Displays help instructions for the present screen.

MEM Key

Accesses the Memory screen for non-volatile memory presets.

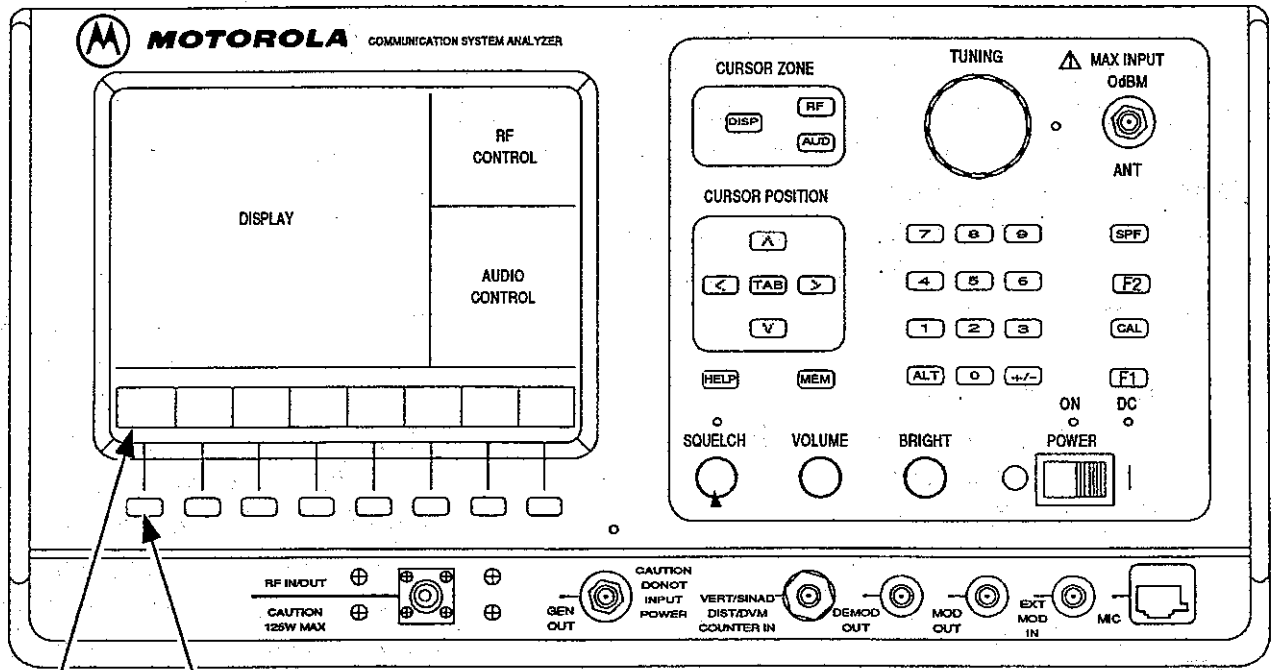

SOFTKEY LABELS SOFTKEYS

Figure 2-1. Front Panel Controls, Indicators, and Connectors

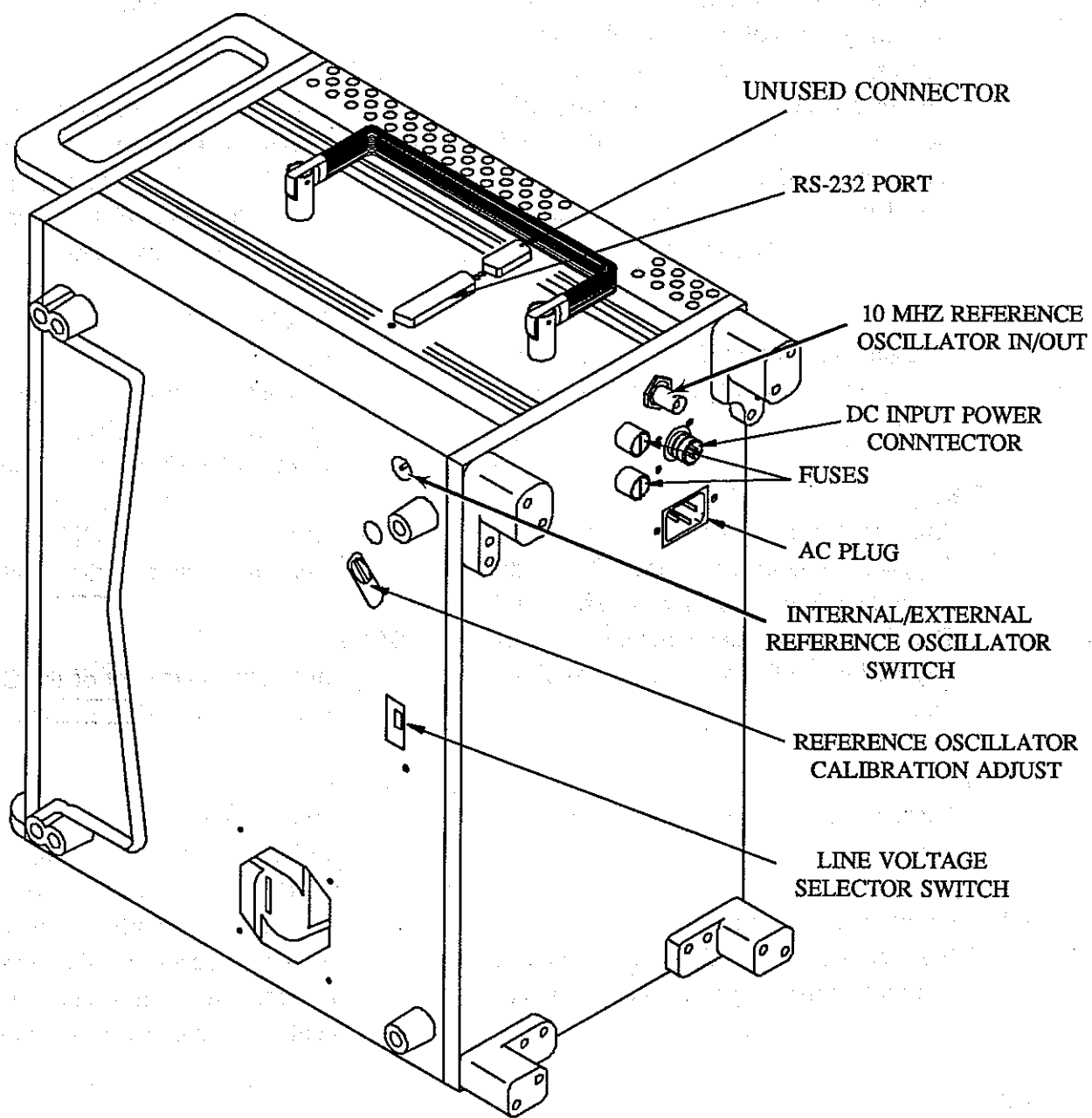

Figure 2-2. Side, Rear, and Bottom Panels

Numeric Keys (0-9)

For entering numeric information into the Analyzer. When a key is pressed, the existing CRT numeral (where the cursor is sitting) is replaced with the numeral represented by the keypress. The Analyzer then reacts to the new information just entered. When an invalid numeric entry is attempted, the Analyzer ignores the keypress and the numeral on the screen remains unchanged.

+/- Key

Toggles the displayed sign from its present value to the negative of its present value.

ALT Key

Enables the alternate functions on the keypad. Upon pressing the ALT key, the message ALT appears on the message line. Pressing any other key following the ALT key will cause the ALT message to disappear.

SPF Key

Displays the special functions menu of the display.

F2 Key (optional function)

Permits access to additional functions. Currently, this key provide no functionality.

CAL Key

Instructs the processor to perform a self calibration on the system.

F1 Key (Optional Function)

Permits access to additional functions. Currently used to return to local mode from remote mode.

Softkeys

Located below the display, the softkeys provide a menu function to indicate all possible values or entries for the current cursor position. If the cursor moves, the softkey functions change.

2-2.2 Knobs

SQUELCH

Squelch control. Clockwise rotation increases the receiver threshold signal level above which the squelch opens.

VOLUME

Controls volume of the speaker audio.

BRIGHT

Intensity adjustment of the CRT. Clockwise rotation results in higher intensity.

TUNING

Incrementally changes the digit over which the cursor is currently sitting. Clockwise rotation of the tuning knob increases the number; counter-clockwise rotation decreases the number. This provides the equivalent of an analog control for numeric cursor entry locations.

2-2.3 CRT

9 cm x 11 cm bit-mapped CRT. Provides data, operating controls, and instructional information. Displays in digital, analog, and bar graph forms.

NOTE

The CRT has a screen saver feature that reduces intensity after approximately 30 minutes of inactivity. Press any key to restore the display.

2-2.4 Connectors

2-2.4.1 Front Panel Connectors

RF IN/OUT

Provides RF input signal to the Analyzer's internal monitor or output signal from the Analyzer's internal generator. Also provides combined input/output in DUPLEX mode. Contains the RF wattmeter load. This is the only front panel connector to which RF power may be applied.

GEN OUT

Provides a high level generator RF output port isolated from the Monitor input. **DO NOT APPLY RF POWER.**

ANT

Input port for sensitive monitor receiver. Useful for off-the-air measurements. **DO NOT APPLY RF POWER.**

NOTE

The GEN OUT and ANT connectors are protected from overload by a 1/16 amp RF fuse installed in the front panel connector. This fuse may be accessed by unscrewing the front portion of the BNC connector from the panel using a 7/16 inch deep socket wrench. Replacement fuse part number is GG-6530277C002.

CAUTION

The RF fuse leads must be trimmed to a length of .48 ±.02 inches and the tips cut to a point to facilitate installation.

VERT/SINAD DIST/DVM COUNTER IN

Combined input port for oscilloscope vertical, SINAD meter, Distortion meter, DVM, and period counter inputs.

DEMOD OUT

Recovered (demodulated) audio output (MONITOR or DUPLEX mode).

MOD OUT

Composite output of internally generated modulation signals.

EXT MOD IN

External modulation input connector. Requires a fixed input level of $1V_{pk}$ for accurate level displays.

MIC

Connector for external accessory microphone.

2-2.4.2 Side Panel Connector

RS-232 PORT (25 pin)

Provides input/output for printer or control interface.

2-2.4.3 Back Panel Connectors

10 MHZ STD

BNC connector provides input/output for 10 MHz reference frequency. Input impedance is 50 ohms. Input level requirement is 70 mV to 1 Vrms. Output level is approximately 250 uVrms.

AC POWER Connector

Primary AC power input port.

DC POWER Connector

Primary DC power input port.

FUSE

Line fuseholders for AC and DC line fuses:

OPERATION	FUSE	PART NUMBER
-----------	------	-------------

110 VAC	3A	65-20404
220 VAC	1.5A	65-890033
12 VDC	10A	65-10266

2-3 BOTTOM CONTROLS

Internal/External Oscillator Micro-Switch

Used to switch between input and output configurations for the rear panel 10 MHz reference oscillator BNC connector.

CAUTION

The R-2550 will not function properly if this switch is set to external without a 10 MHz reference signal applied to the rear 10 MHz reference BNC connector.

Internal Reference Oscillator Adjustment Access

Provides convenient external access to recalibrate reference oscillator frequency setting.

CAUTION

Use a reliable and accurate frequency standard when making this adjustment.

110/220 VAC Selector Switch

Used to switch the unit's internal power supply for either 110V or 220V operation. Check the fuse for proper size when switching to a different line voltage.

Section 3

OPERATING INSTRUCTIONS

3-1 GENERAL

The Analyzer is designed specifically for the service and monitoring of radio communications equipment. This product represents a breakthrough in simplicity of operation. In place of numerous meters, keys and controls, the R-2550 employs a large CRT display which simultaneously presents control and data displays. A simplified front panel, utilizing soft keys, cursor movement keys, a numeric key pad, an analog tuning control and other dedicated function keys all combine to make the unit extremely easy to learn and very efficient to use.

Primary operating modes of the unit are MONITOR, GENERATE, and DUPLEX. They are accessed through the RF Control display area at the upper right of the screen. Within these modes of operation, various measurement functions may be selected in order to measure and diagnose many types of radio equipment under test.

RF data display, voltmeters, distortion meter, SINAD meter, frequency counter and modulation decoder functions are available through the Meter display area at the upper left of the screen.

Spectrum analyzer, oscilloscope and bar graph displays are available through the Display area at the lower left of the screen.

Control of the internal modulation synthesizer and level selection for externally applied modulation are provided through the Audio area at the lower right of the screen.

Further explanation of the function of each of these screen areas can be accessed through use of the HELP key to the lower right of the screen.

3-2 BASIC OPERATION

Control of the unit and selection of data to be displayed are done through the use of three main windows which simultaneously appear on this screen (figure 3-1).

These three main windows, or cursor zones, are accessed simply through a cluster of three CURSOR ZONE keys at the top center of the unit. The location where the cursor rests within each zone is known as a cursor field. To control the unit and enter data, all operator inputs are made at highlighted cursor field locations (brighter-face type).

For further simplicity, softkeys, with customized on-screen labels interact with the screen to provide a unique menu of entry options for each cursor field. This greatly reduces the number of keys and having to search through unrelated controls to find the one that's needed.

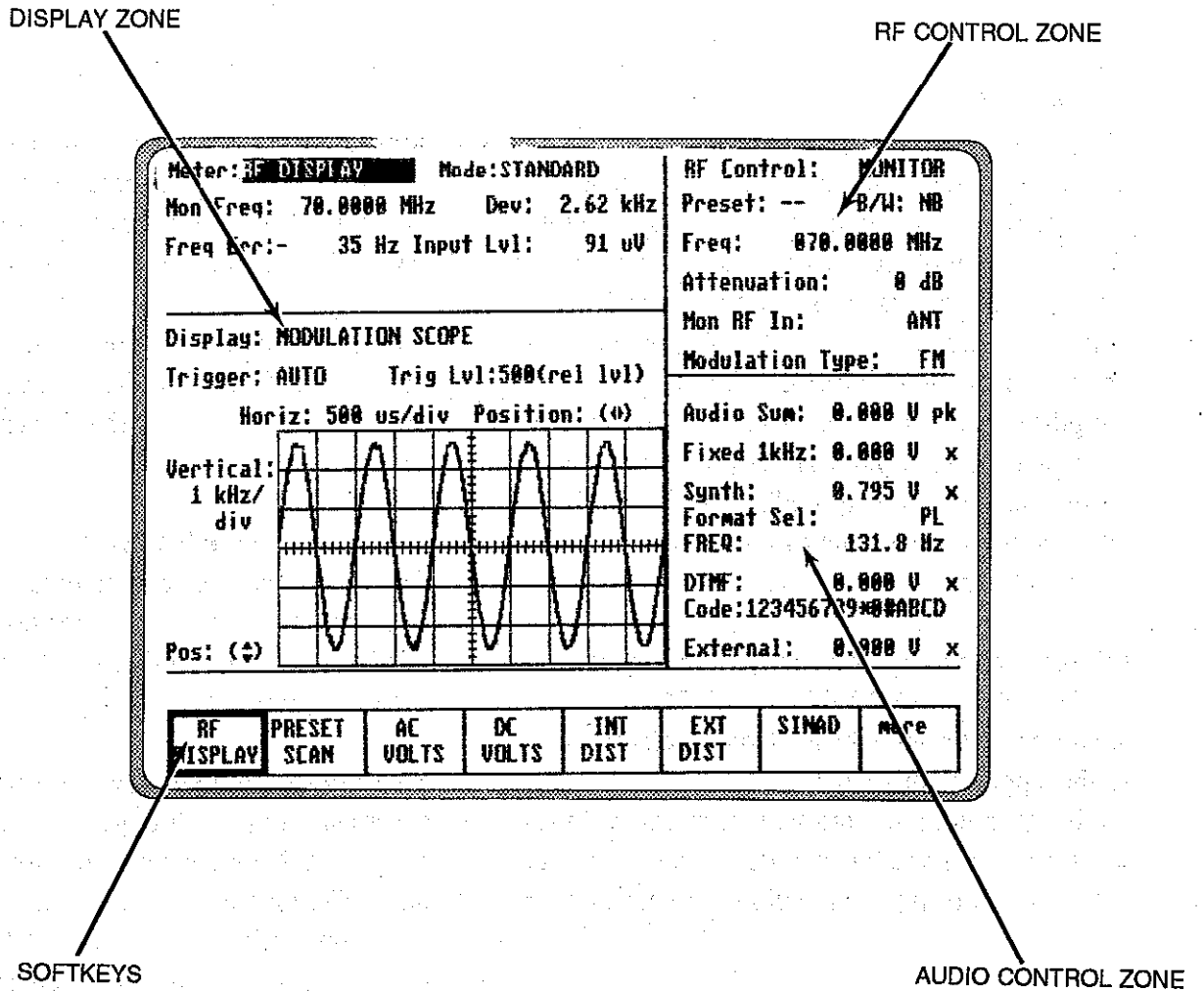

Figure 3-1. Screen Zone Arrangement

Control the cursor location and input information by:

- Using the CURSOR ZONE keys to move the cursor among the three zones.
- Using the CURSOR POSITION keys to move the cursor from field to field within a zone.
- Once at the desired field, use either the TUNING knob or the numeric keys to enter numeric information. Use the softkeys for other menu selections.

3-2.1 Expanded Display

Some functions have the ability to expand their contents and overwrite other display areas. These consist of the following:

- Encode tables
- Dedicated keys

3-2.1.1 Encode Tables

Encode Tables are selected from the "Audio Mod Sum:/Mod Sum:" field). Selection of the General Sequence or DTMF encode modes, and pressing the display table softkey, causes the system to overwrite the meter and display zones with the display tables. Use the return softkey to exit to previous screen.

3-2.1.2 Dedicated Keys

Refer to the Other Functions portion of this manual (paragraph 3-8) for an explanation of expanded screens in the HELP, MEM, SPF, and CAL modes.

3-3 HELP

The Analyzer provides on-screen operating instructions via the dedicated HELP key. Help screens are organized such that each display area has an associated help screen pertaining to that area of the screen. System help (figure 3-2) is available via a softkey within each help screen. Use the return softkey to return to the function in progress.

System Help

1. Operation of this unit is done primarily through the use of softkeys located immediately below the display screen. These keys along with the CURSOR POSITION keys located to the right of the screen provide for the entry of test requirements and the selection of data to be displayed.
2. Each highlighted cursor location has its own unique menu of selections displayed in boxes immediately above the softkeys. Simply push the key below the box to make the selection.
3. Three main windows or cursor zones are used for RF and Audio control on the right and data display on the left. The CURSOR ZONE keys provide for easy movement between these zones. Once in the zone of interest the cursor can be moved between the highlighted entry location by using the five CURSOR POSITION keys.

Page 1 of 3

first page	prev page	next page				return	
---------------	--------------	--------------	--	--	--	--------	--

Figure 3-2. System Help

3-4 WARNINGS

The system provides warnings for the following operating conditions, which are considered detrimental to the proper functioning of the Analyzer:

- RF Overload
(Input level to monitor too great for accurate measurement)
- Recalibrate
(Indicates that the unit's internal temperature has changed more than 10° C from where it was last self-calibrated. This may affect the accuracy of the generator output level, monitor input level below +20 dBm, and modulation level. Refer to paragraph 3-8.3 for further information)
- RF Over Temperature
(Excessive power to RF load)
- Optional Battery Pack Voltage Low

If any of these conditions exist:

- A warning will be displayed on the warning line of the CRT for RF overload, recalibrate, and low battery voltage.
- A continuous audible warning tone along with an overwrite of the screen with a warning message will be presented for RF Over Temperature (figure 3-3). This condition may occur when the intermittent power rating of the 125 watt internal load is exceeded. Both the display and the warning tone remain on and all operator input is ignored until the condition is corrected. The Analyzer then resumes normal operation.

CAUTION

Remove RF power immediately to correct the RF Over Temperature condition. Otherwise damage to the unit may occur.

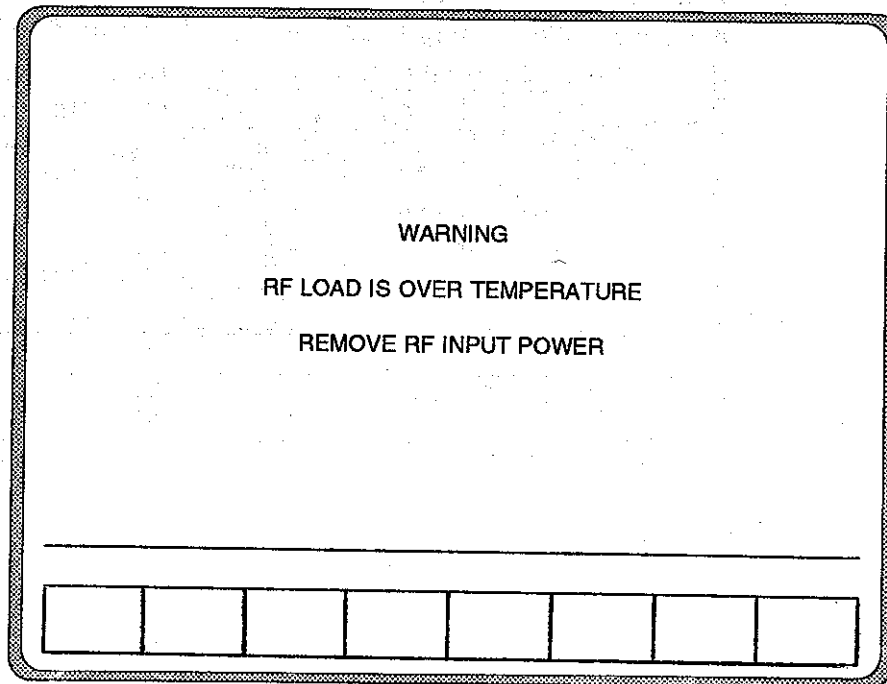

Figure 3-3. RF Over Temperature Warning Message

3-5 PRIMARY OPERATING MODES

Select the operating mode by placing the cursor in the "RF Control:" field in the RF zone. Use the desired softkey to make selection. Primary operating modes are: MONITOR, GENERATE, and DUPLEX.

3-5.1 MONITOR Mode

The Monitor mode (figure 3-4) provides the unit's test receiver function which is used in the testing of radio transmitters. It is capable of monitoring RF input through its antenna or a direct connection to the transmitter to accurately determine the frequency, power level, and modulation characteristics. It monitors signals from 400 kHz to 999.9999 MHz. Center frequency is set in 100 Hz increments. Specific controls which further configure the MONITOR

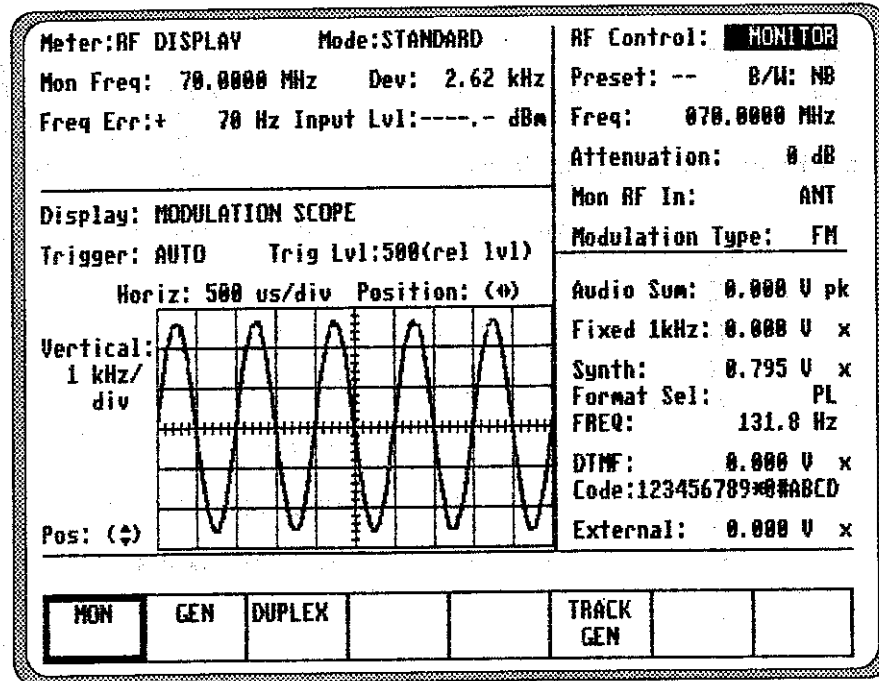

Figure 3-4. Monitor Mode

mode are located within the RF zone when MONITOR is first selected. The specific entry fields are as follows.

Preset

This field allows one of the twenty possible preset monitor/generate frequency pairs to be selected. Frequency memory presets are programmed in the memory screen as discussed in paragraph 3-8.5. When a preset number is entered in this field, the monitor and generate frequencies stored under that number are used by the analyzer for monitor and generate modes.

B/W

Selects either wide or narrow IF and audio bandwidths of the unit via softkey selection.

Freq

Enter the desired monitor frequency using keypad or tuning knob.

Attenuation

Select the amount of attenuation at the RF input to the monitor receiver using softkeys. Selectable input attenuation is useful in adjusting displays for a wide range of input levels, as well as for use in high RF field environments where intermodulation may cause desensitization of the receiver.

Mon RF In

Selects the RF input port via softkeys.

CAUTION

Do not apply input power to the ANT input port. In the event RF power is inadvertently applied, the port is protected by an in-line RF fuse. This fuse may be accessed by unscrewing the front of the BNC connector out of the front panel. Refer to Section 2-1, Description for additional detail.

The RF I/O port contains an RF load and should be used for direct connection to the radio under test. The ANT port accesses the unit's sensitive receiver and should be used with an antenna for "off-the-air" reception. Selection of the ANT port is indicated by a red LED adjacent to the ANT connector.

Modulation Type

Selects the type of modulation via softkeys.

3-5.2 GENERATE Mode

The GENERATE mode (figure 3-5) configures the Analyzer to generate an RF signal at a controllable output level to provide for a wide range of receiver testing. Multiple internal and

external modulation signals can be simultaneously impressed on the carrier frequency to generate composite signals for servicing. Signals from 400 kHz to 999.9999 MHz may be generated. Center frequency is set in 100 Hz increments.

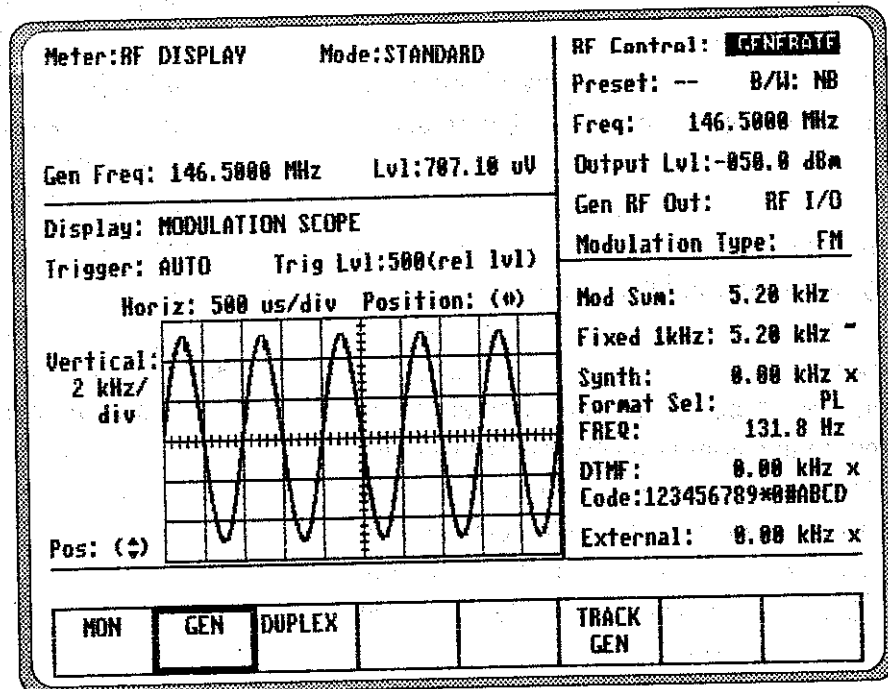

Figure 3-5. Generate Mode

Specific controls which further configure the GENERATE mode are located within the RF Control zone when GENERATE is first selected. The specific entry fields are as follows:

Preset

The preset function is the same as in the MONITOR mode.

B/W

Selects either wide or narrow bandwidth of the unit via softkey selection.

Freq

Enter the desired generate RF frequency using keypad or tuning knob.

Output Lvl

Selects generator output level in 0.1 dBm steps over the range of -130 dBm to 0 dBm. An alternate display of generate level in microvolts is available in the "Meter:" area of the display zone. Output level is available in two ranges depending upon which output port is selected:

- The range of -80 dBm to 0 dBm is available when the high level GEN output port is selected.
- The range of -130 dBm to -50 dBm is available when the RF I/O output port is selected.

NOTE

If AM modulation is selected, the maximum output at the GEN port is reduced to -6 dBm; the maximum output at the RF I/O port is reduced to -56 dBm.

Gen RF Out

Selects the RF output port via softkeys. The RF I/O port is recommended for most applications where GEN and MON ports are combined for a single connection to the radio under test. The GEN port is recommended where higher levels are needed. Selection of the GEN port is indicated by a red LED adjacent to the GEN OUT connector.

CAUTION

Do not apply input power to the GEN output port. In the event RF power is inadvertently applied, the port is protected by an in-line RF fuse. This fuse may be accessed by unscrewing the front of the BNC connector out of the front panel. Refer to Section 2-1, Description for additional information.

Modulation Type

Selects the type of modulation via softkeys.

3-5.3 DUPLEX Mode

The DUPLEX Mode (figure 3-6) provides a simultaneous RF generator output that is offset in frequency from the monitor center frequency and fully adjustable in output level. This capability provides for servicing full duplex radio equipment as well as repeaters and radios operating with offset transmit and receive frequencies.

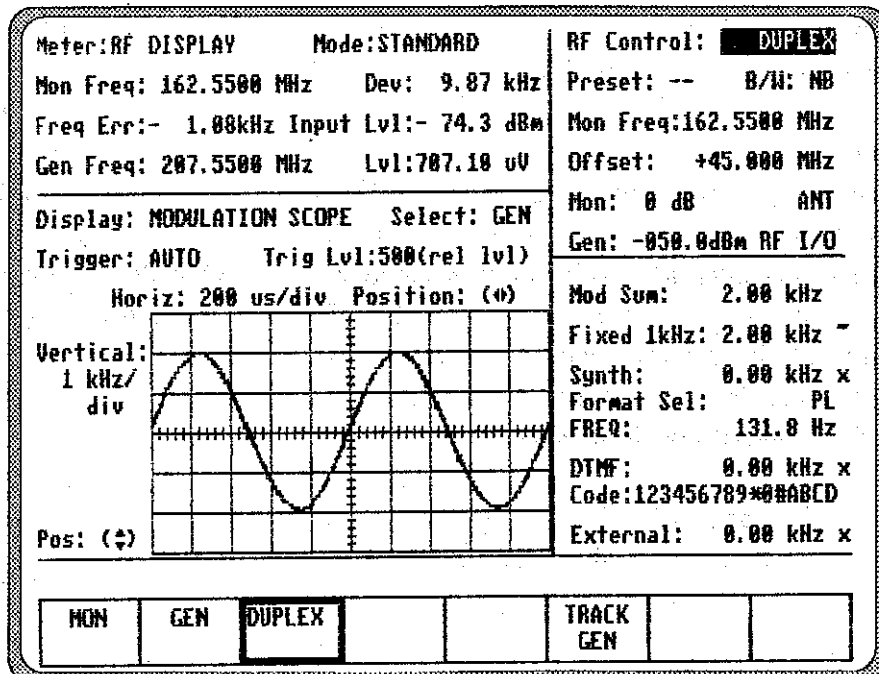

Figure 3-6. Duplex Mode

Specific controls which further configure the DUPLEX mode are located within the RF Control zone when DUPLEX is first selected.

The specific entry fields are as follows:

Preset

The preset function is the same as in the monitor mode. However, when the Duplex mode is activated and a preset number is entered into this field, the duplex offset frequency will be automatically calculated to be the difference between the stored monitor and generate frequencies. If the difference between the stored monitor and generate frequencies is greater than or equal to 55 MHz, the duplex frequency offset will be set to its maximum value of 55 MHz.

B/W

Selects either wide or narrow bandwidth of the unit via softkey selection.

Mon Freq

Enter the desired monitor frequency using keypad or tuning knob.

Offset

Enter the generator frequency offset relative to the monitor frequency entered. Offset frequencies of ± 0 to 55 MHz are allowed. The offset frequency is set in 5 kHz steps.

Mon

This field actually contains two separate fields, one for monitor input attenuation and one for monitor port selection. Refer to the MONITOR description for further details.

Gen

This field actually contains two separate fields, one for generate output level and one for generate output port selection. Refer to the GENERATE description for further details.

NOTE

Only FM modulation is provided for the duplex generator. Either FM or AM demodulation may be selected. Selection must be done in MONITOR Mode within the RF control zone. The RF I/O port combines monitor and generate signals for the duplex function. However, either the ANT or GEN ports may be independently selected.

3-5.4 TRACKING GENERATOR Mode

(Option)

The TRACK GENERATOR mode (figure 3-7) sets up the unit's signal generator in a sweeping mode for use with the optional Tracking Generator display. This provides a valuable capability for measuring and servicing a wide variety of RF filtering and combining networks.

To operate the Tracking Generator, simply select TRACK GEN via softkey in the "RF Control:" field in the RF Control zone. Connect the GEN OUT port to the input of the network under test.

Connect the output of the network under test to the ANT port. Be sure to activate the ANT port thru the "Mon:" field in the RF Control zone. If input attenuation is needed as part of the measurement procedure, 20 or 40 dB attenuation may similarly be selected thru the "Mon:" field in the RF Control zone.

The Tracker display is selected thru softkeys at the "Display:" field of the DISP zone at the left center of the screen. The display is a 10 dB/div

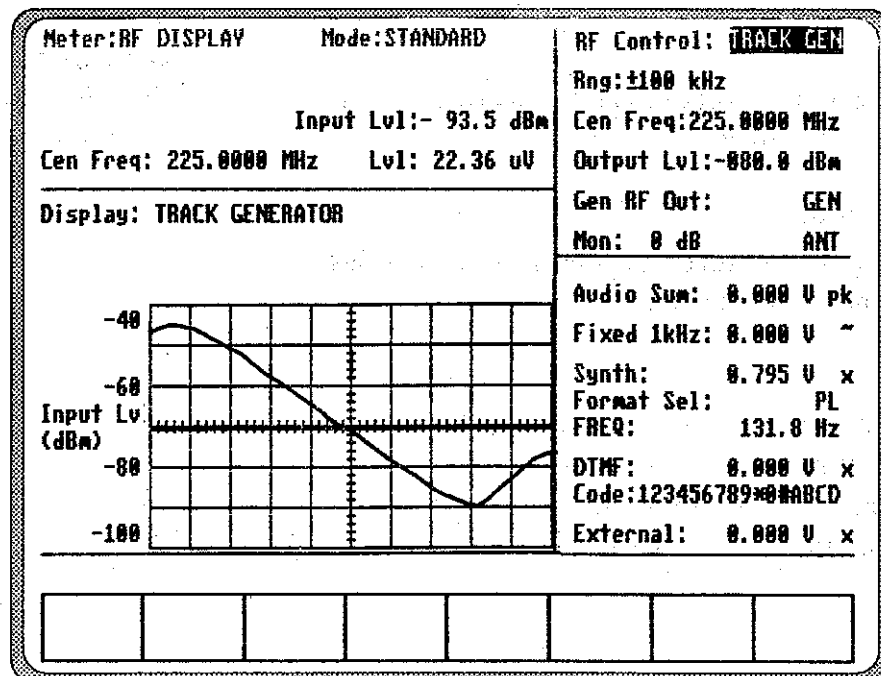



Figure 3-7. Tracking Generator Mode



log scale. By adjusting the generator level and selecting 20 or 40 dB of input attenuation, the usable measurement range is approximately 100 dB at frequencies below 500 MHz and 80 dB above 500 MHz.

All adjustments of center frequency, frequency range and generator level are made thru the RF zone at the upper right of the screen. The TUNING control is especially useful in tuning center frequency and generator level. These may all be adjusted as follows, thru softkeys or numeric entry, for the desired display, depending on the type of network being tested.

Rng



Selects the RF frequency range over which the generator will sweep. These are expressed in \pm full screen deflection ranges that are selectable via softkeys. The sweep rate of the tracking generator is fixed at approximately 50 ms/sweep.

Cen Freq

Selects the center frequency of the Tracking Generator display. See the GENERATE mode for more detail on frequency entry.

Output Lvl

Refer to GENERATE mode.

Gen RF Out

Refer to GENERATE mode.

3-6 AUDIO/MODULATION SYNTHESIZER

The Audio zone located at the lower right of the screen is used to control the multi-purpose audio synthesizer section of the unit. Signals generated by the audio synthesizer are coupled internally to the generator modulation input as well as to the MOD OUT front panel connector.

In the GENERATE and DUPLEX modes, levels entered in the Audio zone are shown as modulation (either deviation or % AM). The composite sum of modulation, only for those modulation sources enabled, is displayed at the top of the zone at the "Mod Sum:" location.

In the MONITOR mode, levels entered in the Audio zone are shown as peak voltage values. The composite sum of the voltage value (only for those modulation sources enabled) is displayed at the top of the zone at the "Audio Sum:" location.

Each of the following modulation signals has a cursor field for entering its desired level. Use the keypad or TUNING knob to enter the desired level.

An additional cursor field, adjacent to each level entry, is used to enable or switch each selection on and off using softkeys. This field is located at the extreme right side of the zone. There are three possible conditions for this softkey selection.

1. CONT activates continuous ON condition, or continuous cycling if a sequence has been selected. A ~ symbol is indicated at the extreme right, adjacent to the level to indicate continuous ON.

2. OFF switches off the modulation source. Off is indicated by an "X" at the extreme right, adjacent to the level.
3. BURST provides a single timed sequence of modulation only for DTMF, TONE A, TONE B, and GENERAL SEQUENCE. A single burst sequence is shown by the "*" symbol.

For DPL, select the START DISC TN (*) softkey to produce a continuous disconnect tone. (Select CONT then "*" softkeys to simulate a complete DPL transmission with disconnect tone.)

The composite sum at the top of the zone will not indicate the burst condition. To set the composite level to include bursts of signaling, temporarily select CONT for those modulation sources which will be "burst" enabled.

3-6.1 Fixed 1 kHz

The Analyzer has a fixed 1 kHz modulation source, which can be selected independently from the other audio synthesizers. Level control and on-off selection is described above.

3-6.2 Synth

Level control and on-off selection are selectable via softkey selection. The synthesizer function encodes a broad selection of signaling formats, which are softkey selected through the "Format Sel:" field adjacent to "Syth:" level field. Use

of the more softkey accesses three different menu levels for the following signaling formats.

PL (figure 3-8)

This softkey selects Motorola Private-Line tone coded squelch signaling. This selection

produces two additional fields on the line below the "Format Sel:" field. The first allows for softkey selection of either frequency or code entry. The second is the value corresponding to the frequency or code. Valid PL codes are found in Appendix B. All frequency entries are accepted, but only valid codes can be entered.

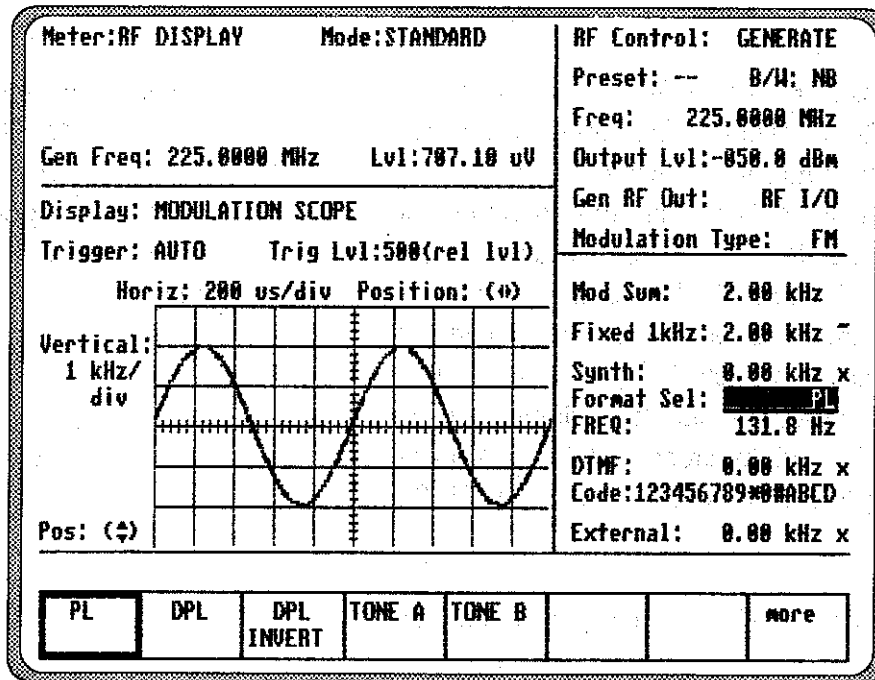

Figure 3-8. PL Format Selection

DPL/DPL INVERT

This softkey selects standard or inverted Motorola Digital Private-Line coded squelch. A single cursor field is located below the "Format Sel:" field for entry of code. Only valid DPL codes should be entered per Appendix B.

TONE A/TONE B

This softkey selects either of two continuous audio tones. Tone frequencies may be entered from the "Freq:" field.

GENERAL SEQ (figure 3-9)

This softkey selects a free-form 10-tone sequence encoding which has full flexibility to enter unique frequency and time duration for each of the 10 tone slots. The single field below the "Format Sel:" field is used to enter the frequency code sequence. An expandable display table is selectable by softkey to allow entry of frequency and time duration data. Frequencies and durations are tabulated corresponding to a given code number (i.e. 1], 2], 3], etc.).

The frequency code sequence can be entered in the expanded display table as well as in the Audio Control zone. The clear to end softkey allows all code numbers entered in the "Code Sequence:" field to the right of the current cursor position to be cleared.

3-6.3 DTMF

Provides a means for encoding DTMF (Dual-Tone Multi-Frequency) signaling for testing telephone interface systems. Enter level as described above and enter "Code:" in the field immediately below the "DTMF:" field.

3-6.4 External

Used to set the level and enable externally applied signals from both the MIC and the EXT MOD IN front panel connectors.

NOTE

In the case of external signals applied to the EXT MOD connector, the accuracy of this level displayed is dependent on applying a fixed signal level of $1 V_{pk}$ ($2 V_{pkpk}$) to the EXT MOD IN connector.

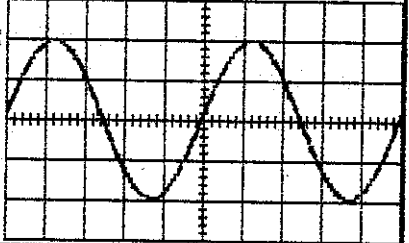
Meter: RF DISPLAY	Mode: STANDARD	RF Control: GENERATE
Gen Freq: 225.0000 MHz	Lvl: 707.10 uV	Preset: -- B/W: NB
Display: MODULATION SCOPE	Trigger: AUTO	Trig Lvl: 500 (rel lvl)
Horiz: 200 us/div	Position: (0)	Output Lvl: -050.0 dBm
Vertical: 1 kHz/div		Gen RF Out: RF I/O
Pos: (0)		Modulation Type: FM
		Mod Sum: 2.00 kHz
		Fixed 1kHz: 2.00 kHz ~
		Synth: 00.0 kHz x
		Format Sel: GEN SEQ
		Code: 0123456789
		DTMF: 0.00 kHz x
		Code: 123456789*0#ABCD
		External: 0.00 kHz x

GENERAL SEQ				display table	more
------------------------	--	--	--	------------------	------

Synthesizer Encode Format Sel GEN SEQ

Code Sequence: 0123456789
(Same code as in Audio Control)

	Freq (Hz)	Dur (sec)
01	19000.0	1.000
11	18000.0	0.900
21	17000.0	0.800
31	16000.0	0.700
41	15000.0	0.600
51	14000.0	0.500
61	13000.0	0.400
71	12000.0	0.300
81	11000.0	0.200
91	10000.0	0.100

				clear to end	return
--	--	--	--	-----------------	--------

Figure 3-9. General Sequence Mode Select

3-7 METER AND DISPLAY

The display of metered data is presented both numerically and graphically within the Display zone in the left portion of the screen (figure 3-10). This zone is divided into two separate display areas: Meter area and Display area.

3-7.1 Meter

Select a measurement display from the following, using softkeys from the "Meter:" cursor field.

3-7.1.1 RF Display

This area displays the RF test data for the radio under test, subject to the mode selected (MONITOR, GENERATE, DUPLEX, or optional TRACK GENERATE).

In the MONITOR Mode, the following data is displayed in the RF Display area.

Mon Freq

Center frequency of the radio under test as entered in the RF Control zone.

Freq Err

This area displays the plus or minus frequency offset (error) of the received carrier relative to the center frequency entered above.

Dev/%AM

Indicates the modulation level of the received carrier, dependent upon the modulation type selected in the RF Control zone.

Note: THE R-2550 ONLY OPERATES IN THE STANDARD MODE

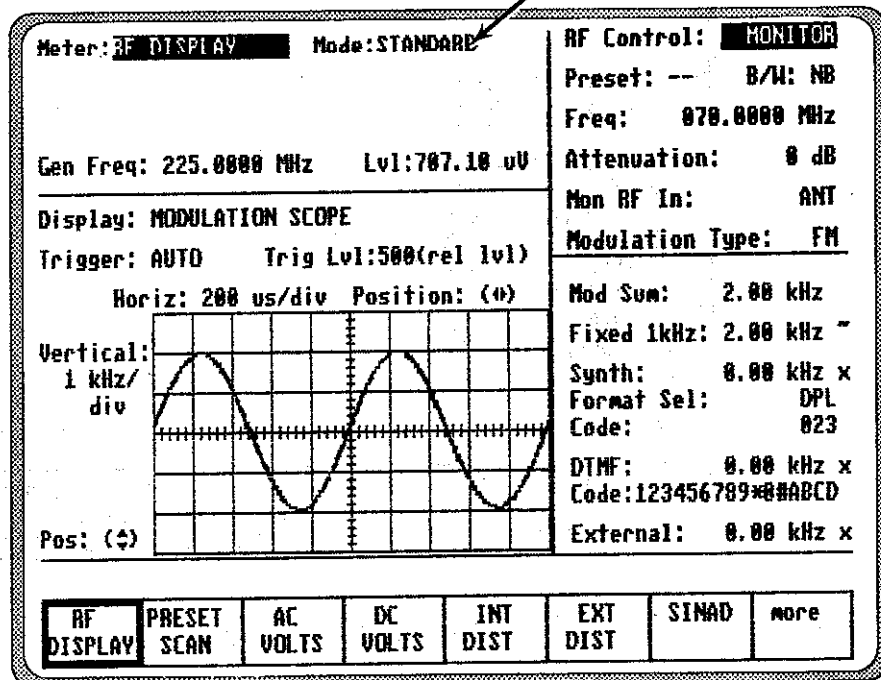

Figure 3-10. RF Display Zone

Input Lvl

Displays the signal level received at the selected front panel connector. This area displays transmitter power for high levels of input as well as lower levels of field strength. Data is displayed only for "on channel" carrier frequencies. A single cursor field at this location allows selection by softkey of either microvolts/watts or dBm units of display.

When the GENERATE mode is selected, the RF Display area shows generator center frequency as well as generate level per the RF Control zone entry. A single cursor field at this location allows selection by softkey of either millivolts/microvolts (mV/uV), dBu, or dBm units of display.

When DUPLEX mode is selected, the RF Display area reflects a combination of the monitor and generator data, as described above.

3-7.1.2 Preset Scan

The R-2550 analyzer provides a preset scan function in which the preset monitor frequencies stored in the RF memory are continually scanned (figure 3-11). The analyzer scans through the preset frequencies, stopping and dwelling on a channel whenever the receiver squelch is broken. When the receiver becomes squelched again, scanning resumes. All 20 preset monitor frequencies, or a subset consisting of a continuous block of frequencies, can be scanned. When no signals are detected, the analyzer scans through all 20 preset frequencies in less than 1/2 second. If the number of preset frequencies to be scanned is reduced, the scanning process is even faster. RF signals to be scanned can be input from either the ANT or RF I/O ports.

While the analyzer is scanning, the "Freq:" fields within the meter zone and RF Control zone indicate **scanning**. When a carrier is

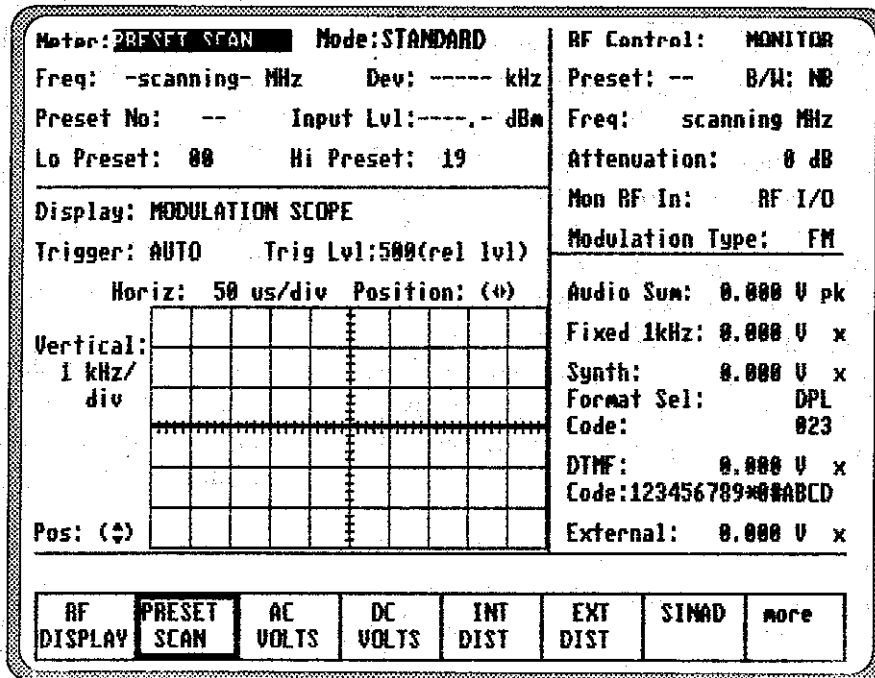

Figure 3-11. Preset Scan Mode

acquired, the "Freq:" field in the RF Control zone indicates **metering** and its counterpart in the meter zone displays the channel on which the carrier was detected. Also displayed in the meter zone are the preset number of the channel, the received power level and the modulation level of the received signal.

To activate the Preset Scan function, depress the Preset Scan softkey. This key not only begins the preset scanning but also serves as a "continue key" to temporarily skip past a channel with heavy radio traffic. When the analyzer is locked on a preset frequency and you wish to continue scanning, although the signal is still present, press the Preset Scan softkey again. This continues the scanning with the next preset frequency in the memory table. Pressing the Preset Scan softkey only skips over a frequency once; if radio traffic is still present on that frequency the next time that it is scanned, the analyzer will stop and dwell once again.

The number of preset frequencies to be scanned can be limited by using the Low Preset and High Preset fields in the meter zone. Entries in these fields will cause the analyzer to only scan from the low preset number to the high preset number. By carefully arranging the preset frequencies in the RF memory into related groups, you can make maximum use of the Low Preset and High Preset scan limiters. For example, a particularly busy preset frequency which is causing the analyzer to stop scanning and dwell for long periods of time can be removed from the scan list by moving it within the RF memory table to a location just above or below the preset numbers being scanned.

It is recommended that frequencies in the RF memory table be grouped according to their modulation type and bandwidth because these parameters must be manually changed in the analyzer's RF Control zone. If an AM frequency (e.g. aircraft band) is intermixed with FM fre-

quencies (e.g. public service band) in the scan list and the analyzer is set to FM mode, radio traffic on the AM frequency will cause the scanner to lock, but the received audio will be unintelligible and the modulation measurement will be meaningless.

Because breaking the receiver squelch causes the analyzer to stop scanning, it is important to properly adjust the squelch control. If the squelch is adjusted too loosely (counterclockwise rotation of the squelch knob), undesired noise signals will break the receiver squelch and the scanning function will not operate properly. If the squelch is adjusted too tightly (clockwise rotation of the squelch control knob), it is possible that desired signals will not be strong enough to break the squelch and the analyzer will not stop and dwell on the channel. To adjust the squelch control for proper scanning operation, turn the squelch control fully counterclockwise and activate the Preset Scan mode. The analyzer will not scan because it will lock on the first frequency due to the squelch being open. Now slowly rotate the squelch control clockwise, just until the squelch light goes out, the noise in the speaker stops and the unit begins to scan. If an actual signal is received while the squelch is being adjusted, wait until it ends before resuming the adjustment. For maximum sensitivity, the squelch level should be adjusted as loose as possible (counterclockwise) without being broken by receiver noise.

To halt the scanning operation at any time, press the RF Display softkey. This stops the scanning and leaves the analyzer locked on the last scanned frequency prior to the key press.

Note: *When the unit is in the Preset Scan mode the response time to key presses will be somewhat slower than normal. For best results, it is recommended that you do not leave Preset Scan active in the Display zone when it is not being used.*

3-7.1.3 AC/DC VOLTMETER

The Analyzer provides a general purpose AC/DC digital voltmeter (figure 3-12). The voltmeter input is the same front panel BNC port that also serves as the input for the SINAD/DIST meter, the VERT oscilloscope input, and the period COUNTER IN.

Move the cursor to the "Range:" field. Select the voltage range (1V, 10V, or 100V DC) by pressing the applicable softkey. Maximum AC range is 70 VAC. If the optional battery pack is installed, an additional selection is available to read the battery voltage.

CAUTION

The maximum analyzer input voltage is 100 volts peak.

The data portion of this screen will show a horizontally oriented bar graph for an analog indication along with a digital readout of the measured voltage (up to 4 digits resolution).

In the AC mode, the measured input is also displayed in dBm, referenced to 1mW into 600 ohms.

3-7.1.4 INT DIST/EXT DIST Meter

The internal and external distortion meter are selectable via softkeys located within the "Meter:" field in the Display zone. The display consists of a digital readout and bar graph. Distortion is used to measure the audio quality of the transmitter and receiver modulation. The distortion meter is selectable via softkey between internal (coupled from the monitor demodulated signal) and external (through the DIST input on the front panel).

The distortion meter operates only at the fixed frequency of 1 KHz.

3-7.1.5 SINAD Meter

The SINAD meter is selected within the "Meter:" field in the Display zone. Display consists of a digital readout and bar graph. SINAD is used in making receiver sensitivity measurements per EIA specifications using a fixed 1 kHz modulation frequency.

Internal coupling for SINAD is not provided; input is always via the external BNC port on the front panel.

3-7.1.6 Counter and Decoding Functions

The following are all accessed via softkey through the "Meter:" field within the Display zone. Their inputs are all normally internally coupled to the monitor demodulated signal for either direct or "off-the-air" testing. If use of these functions is needed for an externally applied signal, the Special Functions screen, under SYSTEM FUNCTIONS, provides a means of switching the input of the Counter/decoder from Internal to External.

These screens contain a "Sensitivity:" field where MIN or MAX may be selected via softkey. This provides a means to desensitize the counter/decoder circuits, if needed to properly measure very high level signals. Under normal operation, this field should be set to MAX.

The display exhibits a digital frequency and equivalent PL code if applicable. Refer to Appendix B for valid codes.

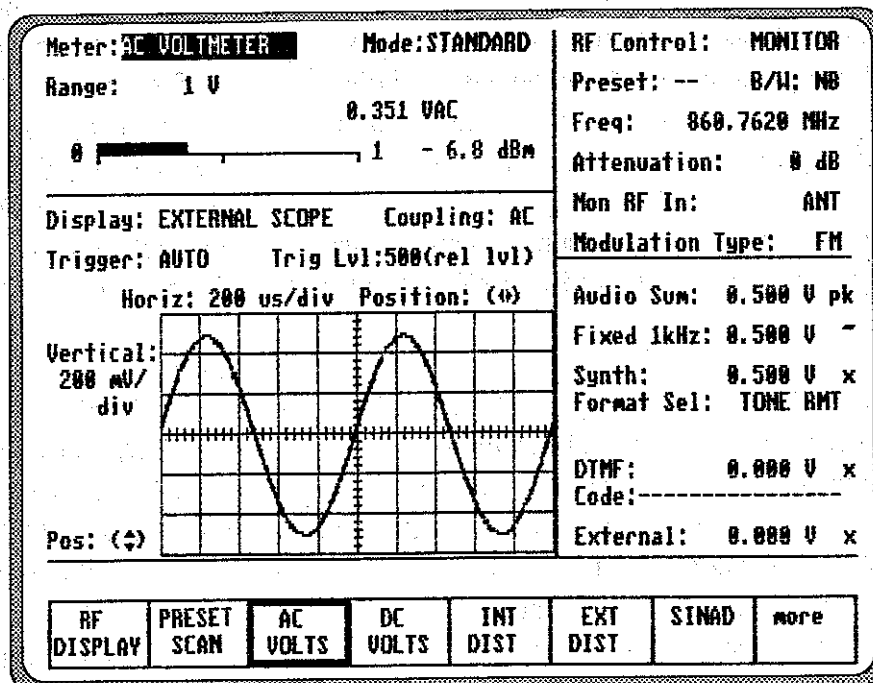
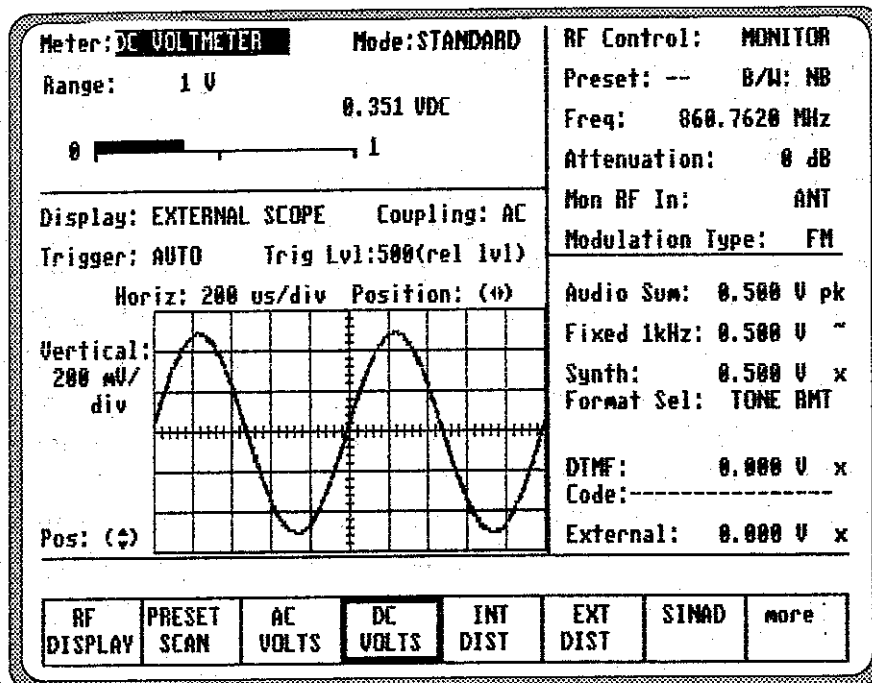

Figure 3-12. Digital Voltmeter Screens

PL/PER Counter

This softkey provides a convenient means of measuring the frequency of Motorola Private-Line (PL) or any other low frequency audio tones with 3 digit resolution. Period measurement makes it possible to measure low frequencies down to high resolution without the need for the long gate times associated with frequency counting.

CAUTION

Do not input frequencies above 400 kHz to the period counter. Slow down of system operations will result.

DPL DECODE

This softkey provides decoding for valid Motorola Digital Private-Line (DPL) codes. Refer to Appendix B for applicable codes. Selection of high and low pass filters may be made from this screen as described above.

DTMF DECODE

This softkey provides a means of decoding DTMF (Dual Tone Multi Freq) signaling for testing telephone interfaced systems. A "reset" softkey clears the display.

3-7.2 Display

Any of the following graphic data displays can be selected for simultaneous display along with the previously discussed meter displays. Select using softkeys from the "Display:" field in the Display zone.

3-7.2.1 Spectrum Analyzer

The Spectrum Analyzer (figure 3-13) is active in the MONITOR or DUPLEX modes. Move the cursor to the "Display:" field within the Display zone.

Select SPECTRUM ANALYZER by pressing the softkey. The input frequency spectrum is displayed in a frequency-versus-amplitude

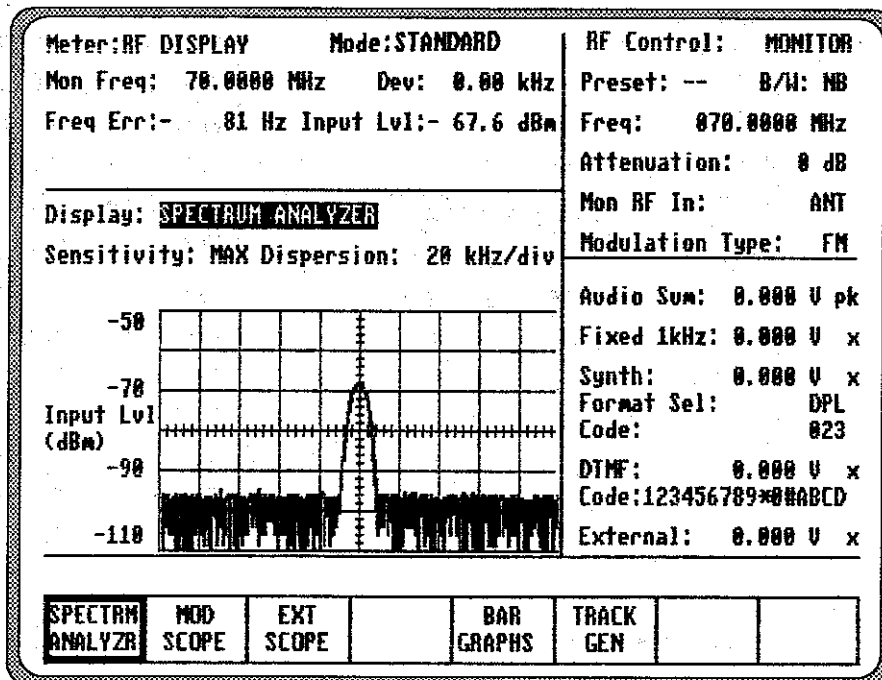

Figure 3-13. Spectrum Analyzer

(dBm) graph. Either the ANT or RF I/O port may be selected for input from the "RF Control:" zone. The amount of input attenuation may also be selected within the zone to vary the sensitivity of the Spectrum Analyzer.

NOTE

If SPECTRUM ANALYZER is selected while the Preset Scan feature is active, the spectrum analyzer will be temporarily disabled during scanning, but will become active again when the analyzer locks onto a signal.

Sensitivity

The SA "Sensitivity: MIN/MAX" field shifts the baseline reference of the display by 10 db. This is valid only for 0 dB input attenuation. Changing the input attenuation or changing from ANT to RF I/O port in the RF Control zone will change the vertical scale of the Spectrum Analyzer display. Calibration is maintained between the display and the signal

level present at the input port so there is no need to compensate for added attenuation.

Dispersion (freq/div)

Select the bandwidth (20 kHz, 50 kHz, 100 kHz, 200 kHz, 500 kHz, 1 MHz) by first moving the cursor to the dispersion field, then pressing the desired softkey. Center frequency is entered from the RF Control zone and may be conveniently varied with the TUNING knob.

3-7.2.2 Modulation Scope

The Modulation Scope (figure 3-14) displays the internal modulation waveforms. It automatically switches between generator or monitor modulation depending on which mode is selected.

In DUPLEX mode, select either generate or monitor modulation displays by first moving the cursor to the "Select:" field within the Display area, then pressing the desired softkey.

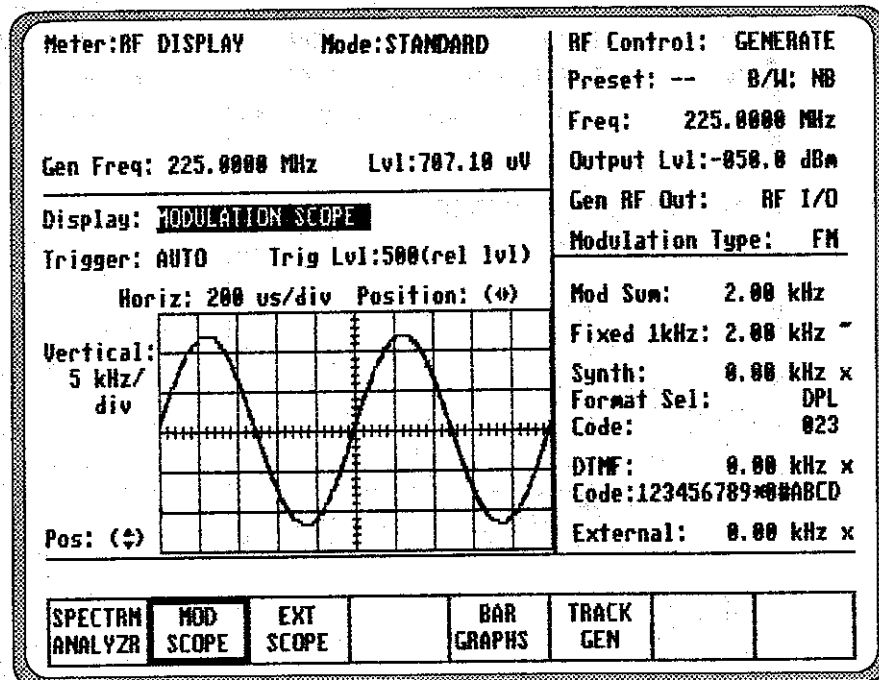

Figure 3-14. Modulation Scope

NOTE

Because the R-2550 Analyzer has a fully digital oscilloscope (storage scope), it inherently has some characteristics which are different from the "real-time" analog scopes familiar to most users. For best overall results, it is recommended that the trigger level be set to 500 and the triggering be set to AUTO.

The Display area of the screen will indicate MODULATION SCOPE with the input signal displayed in a time-versus-frequency graph. To change triggering, horizontal position, horizontal range, vertical position, or vertical range, use the cursor control keys to highlight the appropriate cursor fields as follows:

Trigger

Press the AUTO, NORMAL, or SINGLE SWEEP softkey to select the type of triggering desired. The trigger level synchronizes the horizontal time base to the vertical input signal.

In AUTO mode, the scope will trigger continuously. In this mode, the analyzer will always re-sweep the display even if there is no signal present. The rate will be about 1 per second with no signal present and about 10 per second with signal present.

In NORMAL mode, the scope will trigger when the vertical signal exceeds the trigger level set. In NORMAL mode the analyzer will re-sweep at a rate of 10 per second, with the last screen display remaining after removal of the signal.

In SINGLE SWEEP mode, the scope will trigger one time for each softkey press, subject

to the trigger level setting (triggering always occurs on the rising portion of the applied waveform). Messages on the line just above the softkeys indicate the status of the single sweep. The single sweep is useful in measuring one-time events, such as a tone burst at the beginning of a transmission. Such bursts may be followed by other modulation which would over-write the screen if measured in the NORMAL trigger mode.

Level

Adjust the TUNING knob to select the desired trigger level. The trigger level is a relative level setting between the values of 0 and 999 (full scale) where 0 is the most negative and 999 is the most positive voltage.

NOTE

To achieve the fastest update rate of the display a trigger level setting of 500 is recommended for most applications.

Horiz

Press the desired softkey to select the Horizontal Sweep rate (20 us to 1 second/div). Since all ranges cannot be shown on one screen, press the **more** softkey for additional selections.

NOTE

If horizontal sweep rates of greater than 10 msec/div are selected, the update rate will slow down. A good overall setting for most applications is 200 usec per division.

Horizontal Position

Adjust the horizontal position through the (< >) cursor field either by using the desired softkey (MOVE LEFT, MOVE RIGHT) or by using the rotary TUNING knob.

Vertical Sensitivity

Press the desired softkey to select the Vertical Sensitivity (AM: 1%, to 50% per division, FM: 100 Hz to 50 kHz per division, dependent on bandwidth selected). When all ranges cannot be shown on one screen, press the more softkey for additional selections.

NOTE

The vertical scales and softkeys for FM deviation will change automatically between wideband and narrowband.

Vertical Position

Adjust the vertical position through the (^ v) cursor field either by using the desired softkey (MOVE UP, MOVE DOWN) or by using the rotary TUNING knob.

NOTE

Scale and positioning adjustments are not possible for stored waveforms that are displayed through the use of single sweep or triggering on single non-periodic signals.

3-7.2.3 EXT'L SCOPE

The Analyzer provides a general purpose oscilloscope with calibrated vertical input sensitivities and automatic or triggered horizontal sweep

rates. Use the scope to analyze waveforms, detect asymmetric modulation or audio distortion, trace signals, and troubleshoot.

The vertical (VERT) input is the same BNC port that also serves as the input for DVM, SINAD/DIST meter, and COUNTER IN.

The EXT'L SCOPE mode has an additional cursor field to select "Coupling:" AC or DC via softkey selection. Operation of triggering, ranges, trace positioning and optional markers are the same as described in MODULATION SCOPE above. Vertical ranges will always display in voltage per division in the EXT'L SCOPE mode.

3-7.2.4 Tracking Generator (Option)

This display must work in conjunction with the TRACK GENERATE mode which is selected thru the "RF Control:" field of the RF zone. Refer to paragraph 3-5.4 for a full description of Tracking Generator operation.

3-7.2.5 Bar Graphs

The bar graphs provide a graphical display of the RF Display data from the Meter area of the screen.

NOTE

The Freq. Error bar graph is not available if PRESET SCAN, PL/PER COUNTER, or DPL DECODE are selected in the "Meter:" field area.

3-8 OTHER FUNCTIONS

3-8.1 Audio Monitor

The Analyzer has a speaker for the purpose of audibly monitoring the recovered baseband signal in the MONITOR and DUPLEX modes and the modulating signal in the GENERATE mode. Switching between the two is automatic.

Using the VOLUME control, the input signal to the speaker is adjustable to a maximum level of 0.5 watts rms.

The speaker is also used for audible warnings, such as RF overtemperature.

3-8.2 Remote Operation

To use the remote function, refer to *The Programmer Reference Manual*, 68-80309E55.

3-8.3 Calibration

Calibration of the Analyzer is performed by the following steps.

- a. Press the CAL key to instruct the processor to perform a self calibration on the system. The CAL function provides a self calibration of the units RF generator output level, the monitor input level and the modulation level. All other parameters are not subject to this self-calibration.

This assures the unit's specification accuracy under conditions of ambient temperature extremes and aging. Re-calibration is recommended at weekly intervals or when the re-calibrate warning appears on the screen. Calibration is only recommended after the unit has fully warmed up to oper-

ating temperature unless critical measurements are needed immediately upon turn-on.

CAUTION

Before starting self calibration be sure that the 50 ohm load, attached by chain to the front panel, is connected to the GEN OUT port. This provides the termination which is essential to proper calibration. Also ensure all connections to the RF I/O and ANT connectors are removed.

- b. Press the START softkey to begin the calibration. While the calibration is active, the message **calibrating** appears.
- c. When the calibration has been performed, the message **complete** appears. Press the return softkey or a cursor control key to return to the previous screen.

3-8.4 Special Functions Menu

The Special Function mode (figure 3-15) accessed by pressing the SPF key, provides control over various system conditions as follows:

VERSION

Accesses a display table which provides the internal software version and checksum for the system and any options present.

RS-232 SETUP

Accesses a display table which allows configuration of the RS-232.

SPF RESET

This softkey appears throughout the Special Function screen as a convenience in resetting

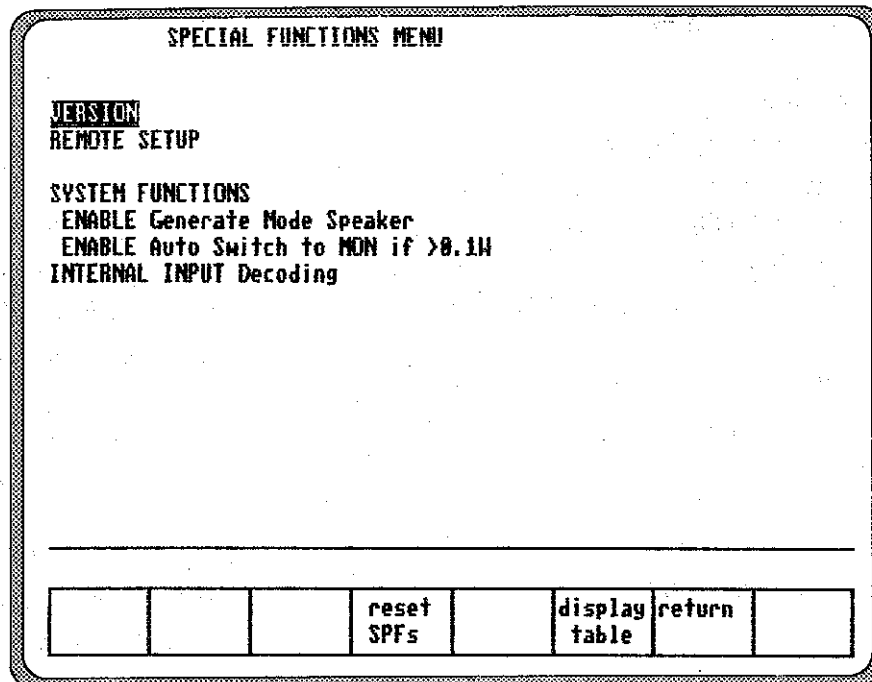

Figure 3-15. Special Functions Menu

of all special functions to the factory standard state. This will switch all decoding to internal.

SYSTEM FUNCTIONS

Accesses softkeys to select the following:

NOTE

*When any of the following special functions are selected, the normal operating screens will flash a warning **SPF Enabled** at the lower right of the screen. This serves as a reminder since special functions inadvertently left enabled can adversely effect normal operation of the unit.*

•NVM Clear

This softkey erases the entire RF Preset-memory area and front panel CAL memory. The Analyzer must be recalibrated after this key has been pressed.

•NVM Reset

This softkey provides a less extensive system reset than NVM Clear. CAL and preset memory are not erased.

•Save State

Sets the current condition and settings of the unit as the power up state.

ENABLE/DISABLE Generate Mode Speaker

Provides the means to disable the internal speaker during generate mode.

ENABLE/DISABLE Auto Switch to MON if 0.1 W

Allows the unit to automatically switch to the MONITOR mode when power levels greater than 0.1 watt are applied to the RF IN/OUT front panel connector.

INTERNAL/EXTERNAL INPUT Decoding

Switches the decoder function between the internal monitor demodulated signal and the signal at the VERT/SINAD front panel connector.

3-8.4.1 Special Function Selection

To select a special function follow the following procedure.

1. Press the SPF key to display the special functions menu on the display.

2. Move the cursor to highlight the field of the function desired. Applicable softkeys will be presented.
3. Use the softkeys to make selections. Levels may be set using the TUNING knob or keypad.
4. Press the return key to return to the previous screen.

3-8.5 Memory

The Memory screen provides for viewing and entry of preset frequencies into non-volatile memory. The actual selection of a preset number for operation of the system can only be done from the RF Control zone.

Pressing the MEM key accesses the memory display (figure 3-16) which shows the 20 presets

MEMORY		Current Preset 001	
Mon Freq (MHz)	Gen Freq (MHz)	Mon Freq (MHz)	Gen Freq (MHz)
001 100.0000	115.0000	101 999.9999	999.9999
011 225.5000	225.5000	111 999.9999	999.9999
021 125.0000	425.0000	121 999.9999	999.9999
031 448.5000	424.5000	131 999.9999	999.9999
041 999.9999	999.9999	141 999.9999	999.9999
051 999.9999	999.9999	151 999.9999	999.9999
061 999.9999	999.9999	161 999.9999	999.9999
071 999.9999	999.9999	171 999.9999	999.9999
081 999.9999	999.9999	181 999.9999	999.9999
091 999.9999	999.9999	191 999.9999	999.9999

Use numeric keys in addition to softkeys

						return	
--	--	--	--	--	--	--------	--

Figure 3-16. Memory Screen

(00 - 19) and the monitor and generate frequencies associated with each.

To change the preset memory frequencies, perform the following steps:

- a. Press the MEM key to access the special Memory screen.
- b. Move the cursor to the appropriate digit of the monitor or generate frequency value displayed, and enter the desired frequency information.
- c. Press the "return" key to return to the previous screen.

Section 4

APPLICATIONS

4-1 BASIC FM TRANSMITTER TESTING

This section of the manual contains information on typical test setups to perform some of the more common radio tests using the R-2550.

Motorola takes no responsibility for application accuracy, applicability, or safety. Always refer to your own transceiver's service manual for recommended test methods and specifications.

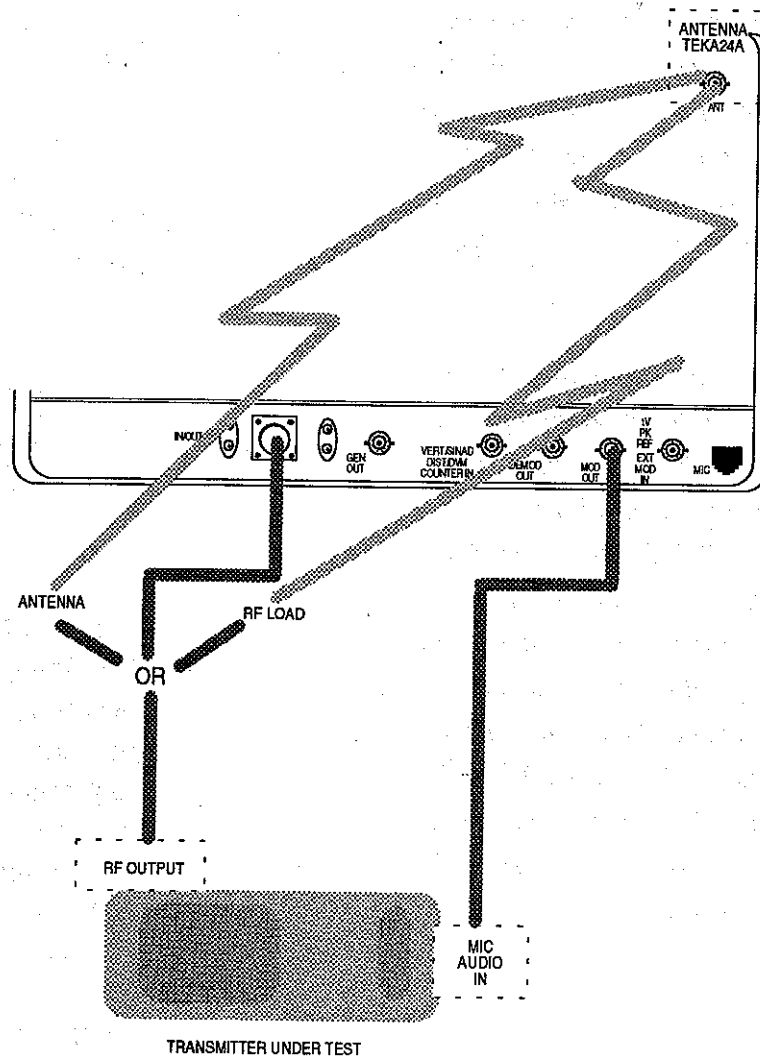

Figure 4-1. Basic FM Transmitter Testing Setup

4-1.1 Basic FM Transmitter Testing Setup

Refer to Figure 4-1. Connect the R-2550 Analyzer RF I/O port to the RF output of the transmitter under test. Connect the R-2550 Analyzer MOD OUT jack to the mic audio input of the transmitter under test.

CAUTION

For transmit power output measurements, connect the transmitter under test only to the R-2550 Analyzer RF I/O port. Do not connect it to the R-2550 Analyzer ANT port. The ANT port is used with an antenna for "off-air" reception.

*The built-in RF load dissipates up to 50 W for three minutes and up to 125 W for one minute. If a high-power transmitter is keyed into the R-2550 Analyzer for a time long enough to threaten overheating the power measuring circuitry, the system's audible alarm sounds and the display changes to the **RF LOAD OVER TEMPERATURE** warning, signaling the operator to unkey (refer to paragraph 3-4).*

4-1.2 Transmit Power, Frequency, and Frequency Deviation Measurements

1. With the cursor located within the RF Control zone (refer to paragraph 3-2), press the **MON** softkey to place the R-2550 Analyzer into its Monitor mode of operation.

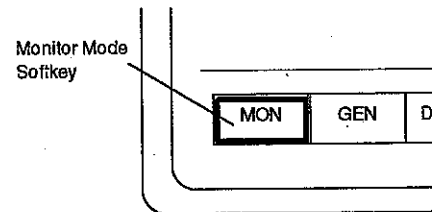

2. Within the RF Control zone, set as follows:

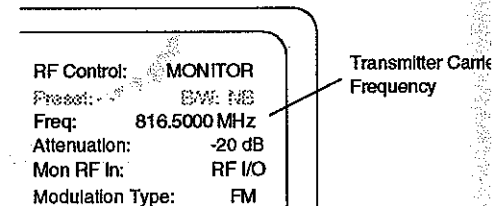

3. Set the **SQUELCH** control to threshold. For low-power transmitters, it may be necessary to use a lower attenuation value in order to unsquelch the monitor (refer to paragraph 3-5.1). Too high of an attenuation setting or too tight a squelch setting inhibits the frequency error reading (refer to paragraph 3-7.1.1). Accurate measurements require sufficient signal level from the radio to fully quiet the R-2550 Analyzer's receiver. Use good quality cable of minimum length to prevent cable-loss which can be a significant

factor in RF power measurements, especially at UHF and above.

4. With the cursor located within the RF Control zone, press the RF DISPLAY soft-key:

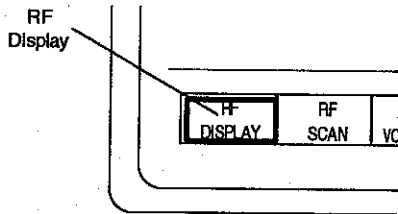

5. Key the transmitter and read the power (Input Level) and frequency error (Freq Err). Refer to your radio's service manual to determine if power and frequency are within specified limits and determine if any adjustments are required.

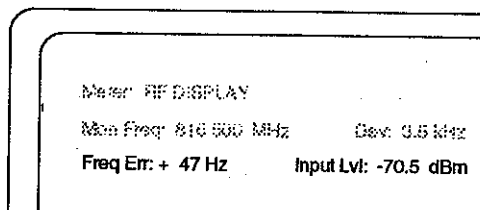

4-1.3 Modulation Measurements

1. Key up the transmitter with appropriate PL (or DPL) enabled.

NOTE: *Microphone pickup of background audio noise in the testing area may result in deviation measurement errors. Consult your transceiver manual for the proper procedure to disable the microphone audio.*

2. When monitoring the PL (or DPL) deviation as follows, refer to your radio's service manual to determine if any adjustments are required.

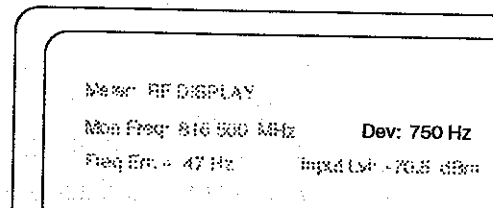

3. Introduce a 1 kHz audio modulating signal from the MOD OUT connector located on the front panel of the R-2550 Analyzer to your radio. Check your radio's service manual to determine the minimum audio signal level required for proper MIC sensitivity as well as the maximum level required to ensure proper IDC (Instantaneous Deviation Control) function.

NOTE: *The voltage levels displayed in the Audio Control zone are peak open circuit voltages. Source impedance of the MOD OUT port is 100 ohms.*

- Turn the 1kHz signal on, and set for minimum level as determined in step 3.

Audio Sum:	0.00 V pk
Fixed 1kHz:	0.40 V ~
Synth:	0.00 V x
Format Set:	PL
FREQ:	131.8 Hz
DTMF:	0.00 V x
Code:	1234567890#ABCD
External:	0.00 V x

- Verify proper MIC sensitivity by reading the deviation. Refer to your radio's service manual to determine maximum rated system deviation to determine if any adjustments are required.

Meter: RF DISPLAY	
Mon Freq: 816.000 MHz	Dev: 3.5 kHz
Freq Err: -47 Hz	Imped Lvl: -70.5 dBm

- Set the 1 kHz audio modulating signal for maximum level as determined in step 3. Repeat steps 4 and 5.

- To measure the percentage of distortion, locate the cursor within the Display Control zone, at the "meter:" field. Press the **INT DIST** softkey to measure percentage of distortion.

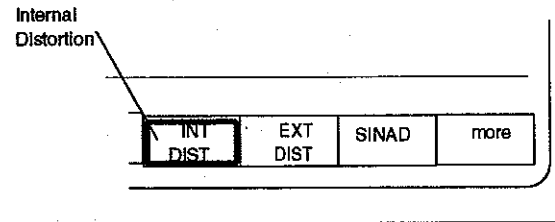

- Refer to the displayed digital readout and bar graph. Refer to your radio's service manual to determine if any adjustments are required.

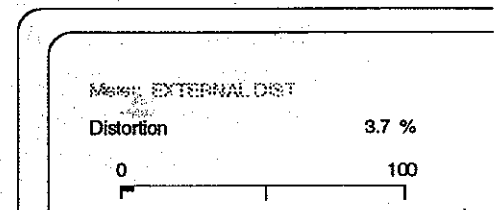

4-1.4 Off-The-Air Measurements

1. Connect the TEKA-24A Pick-Up Antenna to the R-2550 ANT port. Operate the transmitter under test either into its own antenna or into a dummy RF load.
2. With the cursor located within the RF Control zone, press the **MON** softkey to place the R-2550 Analyzer into its Monitor mode of operation.
4. Check transmitter frequency and modulation as detailed in paragraphs 4-1.2 and 4-1.3.

NOTE: *This method may be used to verify frequency and modulation of a remotely located transmitter by reducing the attenuation setting to fully realize the sensitivity of the R-2550 Analyzer "Off-The-Air" monitor function.*

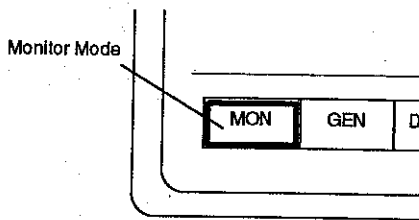

3. Set the SQUELCH control to threshold. Within the RF Control zone, set as follows:

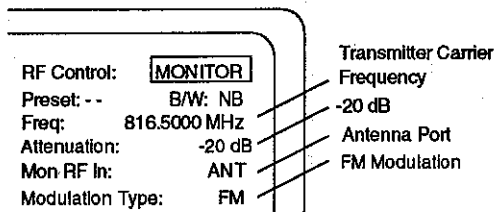

4-2 BASIC FM RECEIVER TESTING

This section of the manual contains information on typical test setups to perform some of the more common radio tests using the R-2550.

The R-2550 Analyzer DVM input is unbalanced (ground referenced). Use an appropriate interface to measure balanced circuits, such as certain receiver audio outputs or telephone lines.

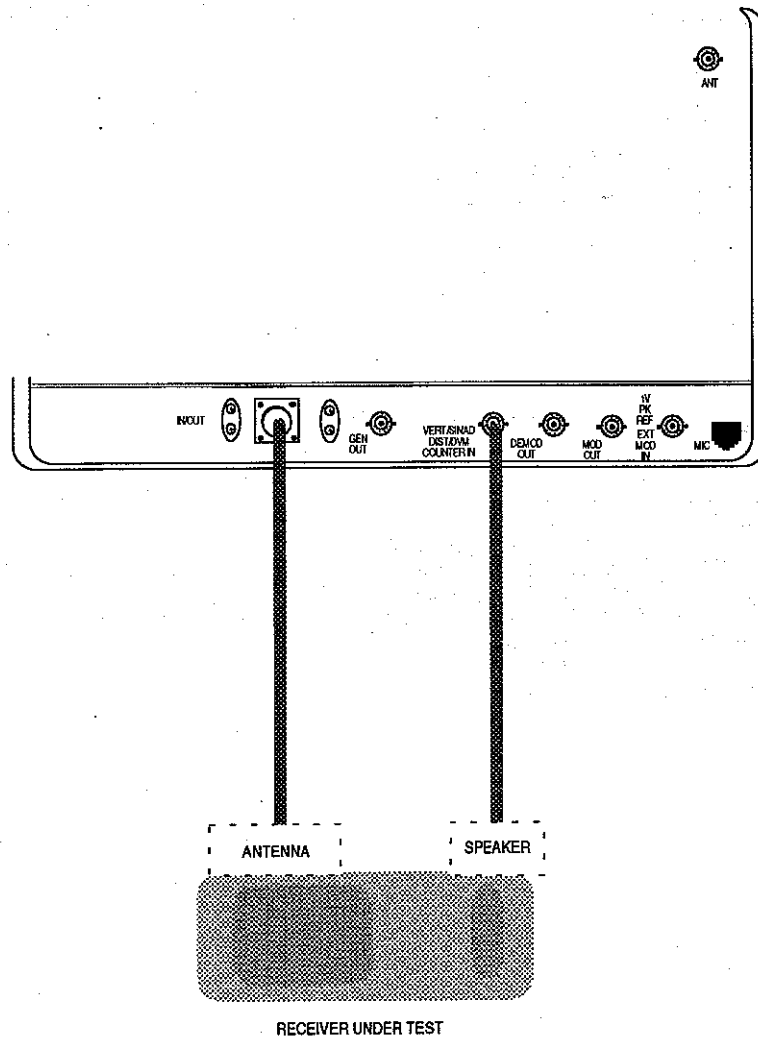

Figure 4-2. Basic FM Receiver Testing Setup

4-2.1 Basic FM Receiver Testing Setup

Refer to Figure 4-2. Connect the R-2550 Analyzer RF I/O port to the radio antenna connector. Connect the radio audio output to VERT/SINAD port of the R-2550 Analyzer.

CAUTION

With some radios, grounding the speaker leads will damage the audio circuitry. Use isolation techniques on these radios.

1. With the cursor located within the RF Control zone (refer to paragraph 3-2), press the **GEN** softkey to place the R-2550 Analyzer into its Generator mode of operation.

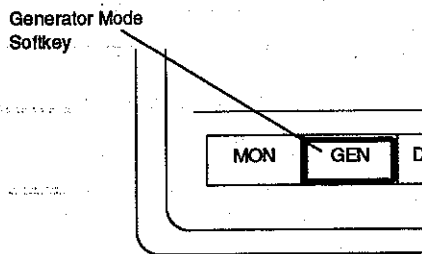

2. Within the RF Control zone, set as follows:

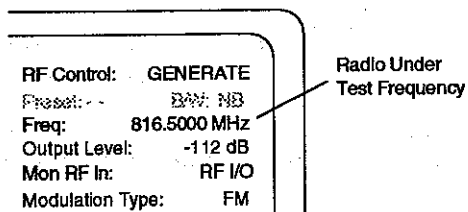

NOTE: *For setup and distortion measurements, set output level to at least 30 dB above sensitivity threshold (-80 dBm recommended).*

3. Within the Audio Control zone, set as follows:

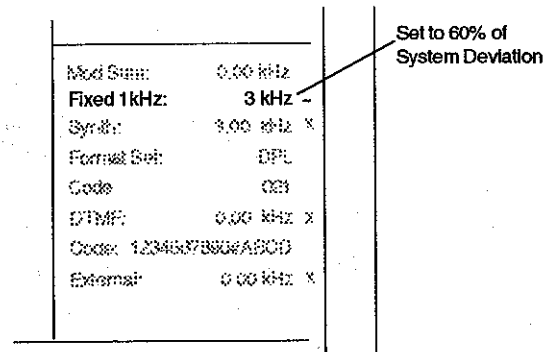

4. With the cursor located within the Display Control zone, press the **AC VOLTS** softkey to display the ac voltmeter:

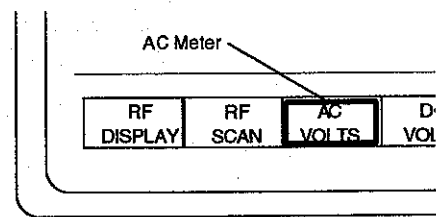

5. Adjust the radio for rated power output by computing voltage needed for rated power with load resistor/speaker in use, and setting the radio volume to produce required voltage.

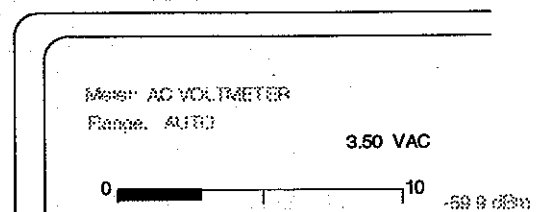

- With the cursor located within the Display Control zone (at Display:), press the **EXT SCOPE** softkey.

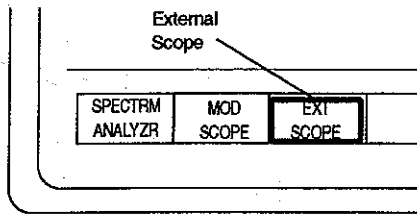

- Set scope vertical and horizontal deflection to observe sine wave from receiver audio.

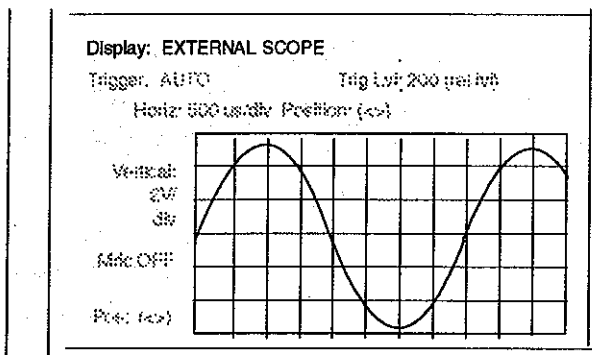

4-2.2 Receiver Distortion Measurement

- With the cursor located within the Display Control zone, press the **EXT DIST** softkey to measure percentage of distortion.

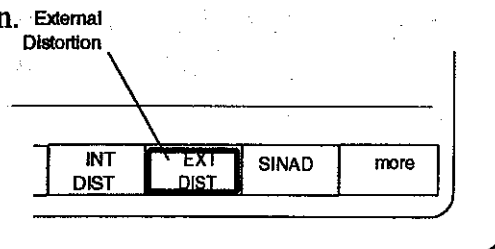

- Refer to the displayed digital readout and bar graph. Refer to your radio's service

manual to determine if any adjustments are required.

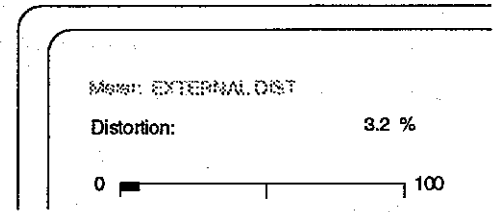

4-2.3 SINAD Measurement

- With the cursor located within the Display Control zone, press the **SINAD** softkey.

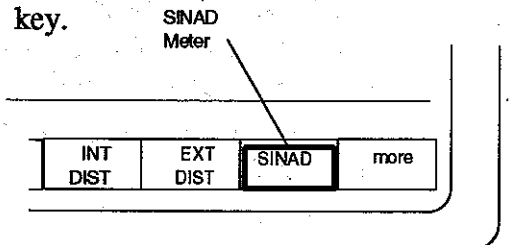

- Refer to the displayed digital readout and bar graph.

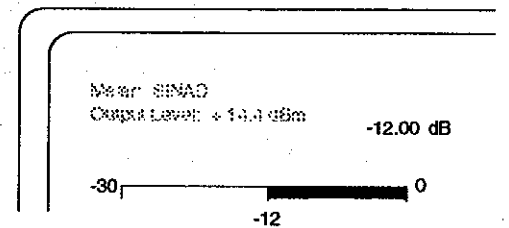

- Within the RF Control zone, adjust the selected RF level until the SINAD reading on the SINAD meter averages 12 dB (instantaneous reading will vary several dB).

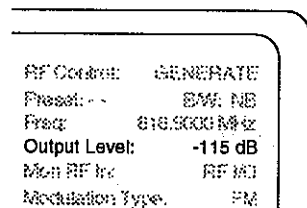

- Note RF output level required for SINAD reading of 12 dB (-115 dBm typical dependent on manufacturers specifications).

NOTE: RF output level can be referenced to mV, uV, dBu, or dBm. Selection of units is available within the Display Control zone (Output Level:).

4-2.4 Modulation Acceptance Bandwidth

- Set the volume control of the radio to 10% of its rated audio output level.
- Set the RF output level 6 dB (doubles the voltage, i.e. 0.35 uV increased 6dB = 0.7 uV) above the RF output level required in paragraph 4-2.3 to achieve the SINAD reading of 12 dB.

RF Control:	GENERATE
Preset:	---
Freq:	810.5000 MHz
Output Level:	-109 dB
Mon RF In:	RF IN
Modulation Type:	FM

Increase 6 dB

- Increase the deviation level until the SINAD meter display returns to 12 dB.

Mod Sum:	0.00 kHz
Fixed 1kHz:	5 kHz
Synth:	9.00 kHz X
Format Set:	DPL
Code:	001
DTMF:	0.00 kHz X
Code:	1234567890*ABCD
External:	0.00 kHz X

Increase as required

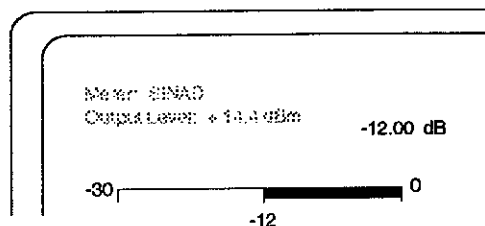

- Read the deviation level required in step 3. A typical modulation acceptance bandwidth of a 5 kHz receiver is 7 to 8 kHz. Refer to your radio's service manual to determine if any adjustments are required.

Mod Sum:	0.00 kHz
Fixed 1kHz:	7 kHz X
Synth:	9.00 kHz X
Format Set:	DPL
Code:	001
DTMF:	0.00 kHz X
Code:	1234567890*ABCD
External:	0.00 kHz X

4-2.5 Receiver Sensitivity Testing (20 dB Quieting)

- With the cursor located within the RF Control zone, press the **MON** softkey to remove input signal from the radio.

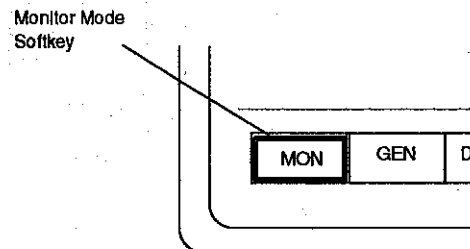

- With the cursor located within the Display Control zone, press the **AC VOLTS** softkey to display the ac voltmeter:

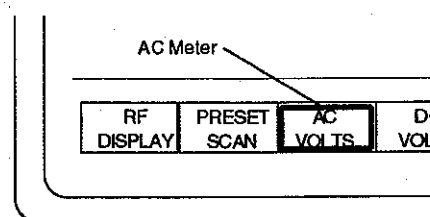

- Turn on the receiver (unscelched). Increase the receiver volume control to feed audio noise to the R-2550 Analyzer (at least 1/4 the rated audio power). Record the noise reading in dBm.

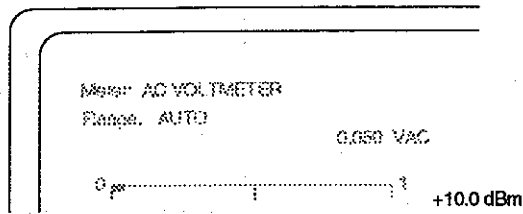

- With the cursor within the RF Control zone, press the **GEN** softkey.

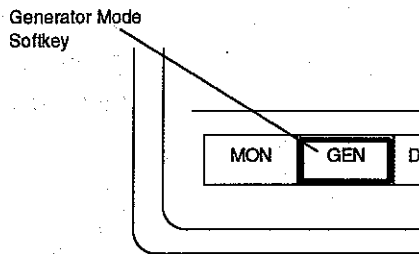

- Within the Audio Control zone, set the modulation off.

Mod Bw:	0.00 kHz
Fixed 1kHz:	7 kHz x
Syn Bw:	9.00 kHz x
Format Set:	DPL
Code:	000
D/TMF:	0.00 kHz x
Code:	1234567890ASCD
External:	0.00 kHz x

- Within the RF Control zone, adjust the RF output level until the noise reading is less than 20 dB from the value recorded in step 3. Refer to your radio's service manual to determine if any adjustments are required.

NOTE: To convert the RF output level to μV or dBV , locate the cursor within the Display Control zone and press the **RF DISPLAY** softkey. Locate the cursor to units used for Lvl: and select the required unit using the softkeys.

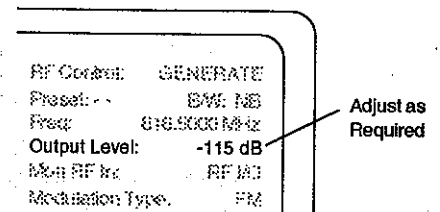

4-2.6 Squelch Sensitivity Test

- With the cursor located within the RF Control zone, press the **MON** softkey.

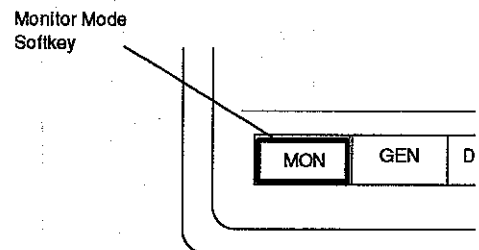

2. Disable the PL/DPL squelch if so equipped. Set the radio's squelch control to the point where the receiver barely quiets.

NOTE: To convert the RF output level to μV or dBV , locate the cursor within the Display Control zone and press the **RF DISPLAY** softkey.

3. With the cursor located within the RF Control zone, press the **GEN** softkey.

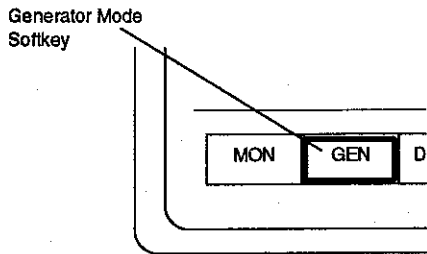

6. Repeat step 5 with the radio's squelch level set to maximum tightness to determine the tight squelch sensitivity of the radio.

7. To check PL/DPL squelch sensitivity, locate the cursor within the Audio Control zone and enter the proper PL frequency or DPL code per Appendix B.

4. Within the Audio Control zone, set the modulation off.

Mod Sum:	0.00 kHz
Fixed 1kHz:	7 kHz x
Synth:	0.00 kHz x
Format Sel:	DPL
Code:	001
DTMF:	0.00 kHz x
Code:	1234567890*ABCD
External:	0.00 kHz x

Audio Sum:	0.00 V pk
Fixed 1kHz:	0.00 V x
Synth:	0.00 V x
Format Sel:	PL
FREQ:	131.8 Hz
DTMF:	0.00 V x
Code:	1234567890*ABCD
External:	0.00 V x

OR

5. Within the RF Control zone, increase the RF output level until the receiver just un-squelches. This is the threshold squelch sensitivity of the radio.

RF Control:	GENERATE	
Preset:	--	EMF NE
Freq:	810.0000 MHz	
Output Level:	-115 dB	Adjust as Required
Mon RF In:	RF IN	
Modulation Type:	FM	

Audio Sum:	0.00 V pk
Fixed 1kHz:	0.00 V x
Synth:	0.00 V x
Format Sel:	DPL
Code:	23
DTMF:	0.00 V x
Code:	1234567890*ABCD
External:	0.00 V x

- With the cursor located within the Audio Control zone, turn on the modulation and set the R-2550 synthesizer to provide a nominal 750 Hz (500 - 1 kHz) deviation or to the radio's manufacturer's specifications.

Mod Sum:	0.00 kHz
Fixed 1kHz:	5 kHz -
Synth:	0.75 kHz -
Format Set:	DPL
Code:	001
DTMF:	0.00 kHz x
Code:	1234567890ABCDEF
Extrem:	0.00 kHz x

- Enable the radio's PL/DPL squelch circuit. Fully open the carrier squelch control.
- Within the RF Control zone, increase the RF output level until the receiver just un-squelches. This is the coded squelch sensitivity.

RF Control:	GENERATE
Preset:	EMF: NE
Freq:	818.000 MHz
Output Level:	-112 dB
Mon RF In:	RF MO
Modulation Type:	FM

Adjust as Required

Appendix A

LIST OF ABBREVIATIONS

A	Ampere	Div	Division
AC	Alternating Current	DPL	Digital Private Line, a Motorola registered trademark
AM	Amplitude Modulation		
ATTEN	Attenuation	DTMF	Dual-tone multi-frequency
AUTO	Automatic	Dur	Duration
BATT	Battery	DVM	Digital Voltmeter
BNC	Coaxial RF Connector	EEA	Electronic Engineering Association
BW	Bandwidth		
C	Celsius	EIA	Electronics Industry Association
CAL	Calibrate		
CCIR	International Radio Consultative Committee	Ext'l	External
C&E	Communications and Electronics (part of Motorola)	FM	Frequency Modulation
cm	Centimeters	FREQ	Frequency
CMOS	Complementary Metal Oxide Semiconductor	GEN	Generate
Cntr	Counter	GHz	Gigahertz
CRT	Cathode Ray Tube	Horiz	Horizontal
CW	Continuous Wave	Hz	Hertz
dB	Decibel	IC	Integrated Circuit
dBc	Decibel (referred to carrier)	IDC	Instantaneous Deviation Control
dBm	Decibel (referred to 1 mW into 50 ohms)	IEEE	Institute of Electrical and Electronics Engineers
DC	Direct Current	IF	Intermediate Frequency
Demod	Demodulation	I/O	Input/Output
DEV	Deviation	Kohm	Kilohm
Disp	Dispersion	kHz	Kilohertz
DIST	Distortion	LED	Light-Emitting Diode

LIST OF ABBREVIATIONS-CONTINUED

Lvl	Level	SEQ	Sequence
MHz	Megahertz	SINAD	Ratio of (Signal + Noise + Distortion)/(Noise + Distortion)
MIC	Microphone		
MIN	Minimum	SPF	Special Function
MOD	Modulation	STD	Standard
MON	Monitor	SW	Switch
us	Microsecond	SWP	Sweep
ms	Millisecond	Synth	Synthesizer
MSEC	Millisecond	TN	Tone
Mtr	Metering	Trig	Trigger
MV	Millivolts	TX	Transmitter
uV	Microvolts	UHF	Ultra High Frequency
mW	Milliwatt	V	Volts
n	Number	VAC	Volts Alternating Current
N/A	Not Applicable	VDC	Volts Direct Current
NB	Narrow Bandwidth	Vert	Vertical
NVM	Non-volatile memory	VRMS	Volts (root-mean-square)
ORIG	Originated		
PCT	Percent	W	Watts
PL	Private Line, a Motorola registered trademark	WB	Wide Bandwidth
+/-	Plus or minus	XCVR	Transceiver
PRT	Print	XX	(Select Any Valid Number)
RF	Radio Frequency		
RMS	Root-Mean-Square		
Rng	Range		
RS	Receiver Specification		
SEC	Second		

Appendix B

TONE AND CODE SPECIFICATIONS

Table B-1. Standard DTMF Tones

TONE GROUP	STANDARD DTMF (Hz)
LOW	697
LOW	770
LOW	852
LOW	941
HIGH	1209
HIGH	1336
HIGH	1477
HIGH	1633

Table B-2. DTMF Frequency Coding*

KEY	LOW GROUP TONE (Hz)				HIGH GROUP TONE (Hz)			
	697	770	852	941	1209	1336	1477	1633
1	•				•			
2	•					•		
3	•						•	
A	•							•
4		•			•			
5		•				•		
6		•					•	
B		•					•	•
7			•		•			
8			•			•		
9			•				•	
C			•				•	•
*				•	•			
O				•		•		
#				•			•	
D				•				•

* The R-2550 has provisions for encoding and decoding 16 different keys. Each key is assigned two frequencies: one from a low tone group and one from a high tone group. Four tones are available from each group, with 16 different combinations of low and high group tones. This table show the tone assignments of each key.

Table B-3. Private-Line (PL) Codes

CODE	FREQUENCY (Hz)
XZ	67.0
WZ	69.3
XA	71.9
WA	74.4
XB	77.0
WB	79.7
YZ	82.5
YA	85.4
YB	88.5
ZZ	91.5
ZA	94.8
ZB	97.0
1Z	100.0
1A	103.5
1B	107.2
2Z	110.9
2A	114.8
2B	118.8
3Z	123.0
3A	127.3
3B	131.8
4Z	136.5
4A	141.3
4B	146.2
5Z	151.4
5A	156.7
5B	162.2
6Z	167.9
6A	173.8
6B	179.9
7Z	186.2
7A	192.8
M1	203.5
8Z	206.5
M2	210.7
M3	218.1
M4	225.7
9Z	229.1
M5	233.6
M6	241.8
M7	250.3

Table B-4. DPL Standard Codes

023	174	445
025	205	464
026	223	465
031	226	466
032	243	503
043	244	506
047	245	516
051	251	532
054	261	546
065	263	565
071	265	606
072	271	612
073	306	624
114	311	627
115	315	631
116	331	632
125	343	654
131	351	662
132	364	664
134	365	703
143	371	712
152	411	723
155	412	731
156	413	732
162	423	734
165	431	743
172	432	

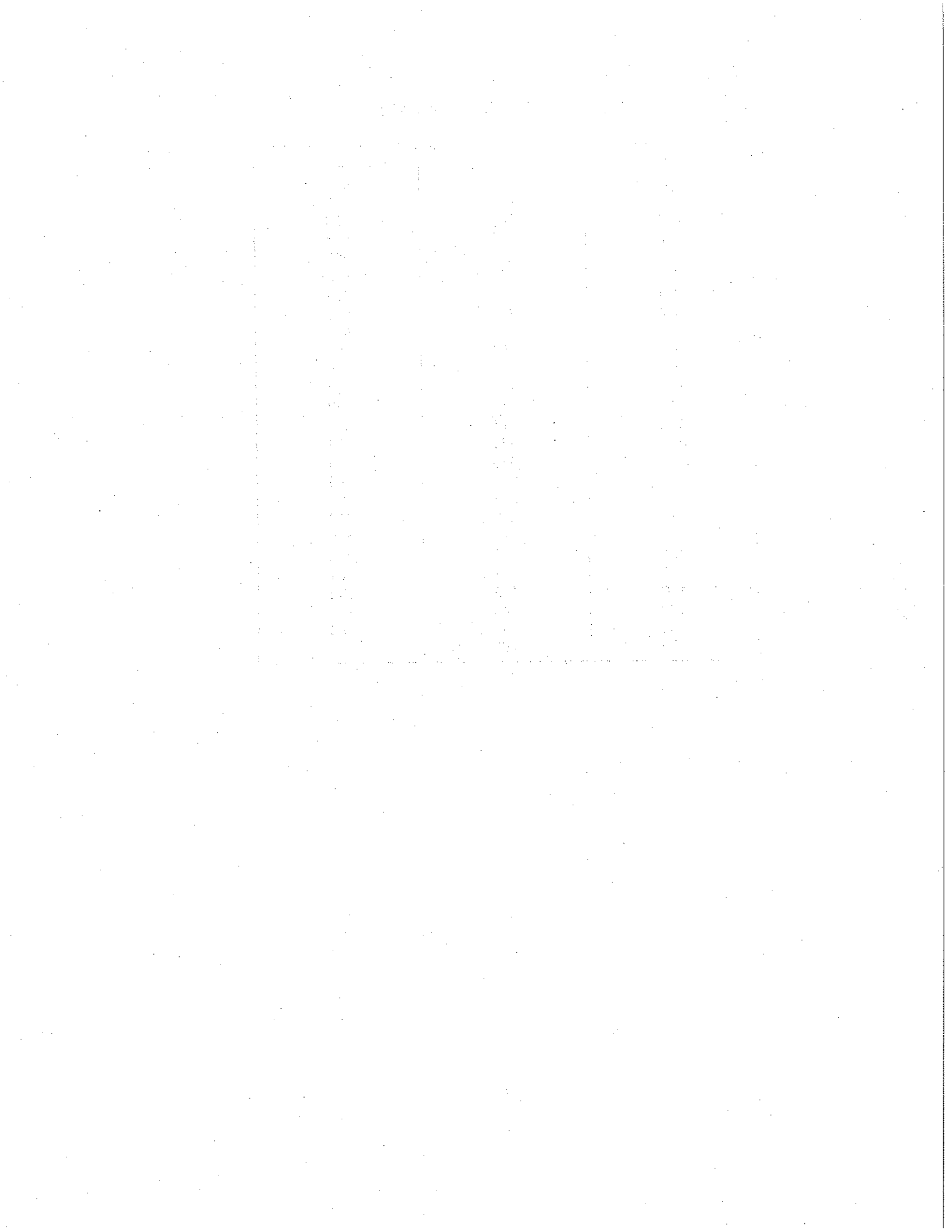

Appendix C

SAFE HANDLING OF CMOS INTEGRATED CIRCUIT DEVICES

Many of the integrated circuit devices used in communications equipment are of the CMOS (Complementary Metal Oxide Semiconductor) type. Because of their high open circuit impedance, CMOS ICs are vulnerable to damage from static charges. Care must be taken in handling, shipping, and servicing them and the assemblies in which they are used.

Even though protection devices are provided in CMOS IC inputs, the protection is effective only against overvoltage in the hundreds of volts range such as are encountered in an operating system. In a system, circuit elements distribute static charges and load the CMOS circuits, decreasing the chance of damage. However, CMOS circuits can be damaged by improper handling of the modules even in a system.

To avoid damage to circuits, observe the following handling, shipping, and servicing precautions.

1. Prior to and while servicing a circuit module, particularly after moving within the service area, momentarily touch both hands to a bare metal earth grounded surface. This will discharge any static charge which may have accumulated on the person doing the servicing.

NOTE

Wearing Conductive Wrist Strap (Motorola No. RSX-4015A) will minimize static buildup during servicing.

WARNING

When wearing Conductive Wrist Strap, be careful near sources of high voltage. The good ground provided by the wrist strap will also increase the danger of lethal shock from accidentally touching high voltage sources.

2. Whenever possible, avoid touching any electrically conductive parts of the circuit module with your hands.
3. Normally, circuit modules can be inserted or removed with power applied to the unit. However, check the INSTALLATION and MAINTENANCE sections of the manual as well as the module schematic diagram to insure there are no objections to this practice.
4. When servicing a circuit module, avoid carpeted areas, dry environments, and certain types of clothing (silk, nylon, etc.) because they contribute to static buildup.

5. All electrically powered test equipment should be grounded. Apply the ground lead from the test equipment to the circuit module before connecting the test probe. Similarly, disconnect the test probe prior to removing the ground lead.
6. If a circuit module is removed from the system, it is desirable to lay it on a conductive surface (such as a sheet of aluminum foil) which is connected to ground through 100k of resistance.
7. When soldering, be sure the soldering iron is grounded.
8. Prior to connecting jumpers, replacing circuit components, or touching CMOS pins (if this becomes necessary in the replacement of an integrated circuit device), be sure to discharge any static buildup as described in procedure 1. Since voltage differences can exist across the human body, it is recommended that only one hand be used if it is necessary to touch pins on the CMOS device and associated board wiring.

WARNING

If the aluminum foil is connected directly to ground, be cautious of possible electrical shock from contacting the foil at the same time as other electrical circuits.

Appendix D

EXTERNAL PORT PIN ASSIGNMENTS

RS-232 PORT

This is a full bidirectional RS-232 port with the capability to respond to a serial input. The port serves a dual purpose in that if an RS-232 is not desired, the port can be used as a printer output. Software determines if the port functions as an RS-232 bidirectional port or as an output-only printer port. 25 pin female "D" connector on Processor Module for RS-232 interface at the side panel. Drawing shows pins as seen from a side view of the Analyzer.

PIN

1	GND
2	TXD (transmit data)
3	RXD (receive data)
4	RTS (request to send)
5	CTS (clear to send)
6	DSR (data set ready)
7	SIG GND (signal ground)
8	DCD* (data carrier detect)
9-19	not used
20	DTR* (data terminal ready)
21-25	not used

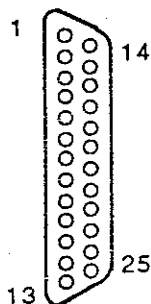

DCD* (Data Carrier Detect) input is not used in this application.

DSR* (Data Set Ready) is a general purpose input that is used for modem control. This line is not used when a printer is connected.

DTR* (Data Terminal Ready) is a general purpose output to indicate the Analyzer is ready to receive more data on the RXD line.

RTS* and CTS* (Request-To-Send, Clear-To-Send) are handshaking signals used in RS232 communications.

RXD (Receive Data) input signal is the data received. If this connector is used as a printer output, the RXD pin is not used.

TXD (Transmit Data) output signal is the data being transmitted.

REAR PANEL DC INPUT PORT

Drawing shows pins as seen from a rear view of the Analyzer.

Positive DC voltage must be between +11 and +18VDC.

Either "+" pin may be used for the positive DC voltage since these two pins are tied together at the 10 amp DC fuse.

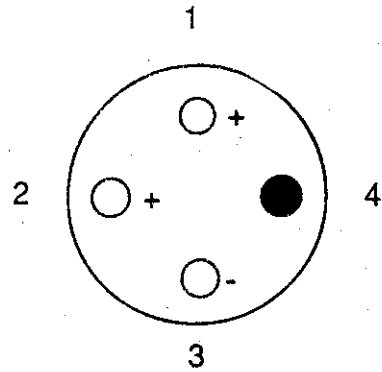

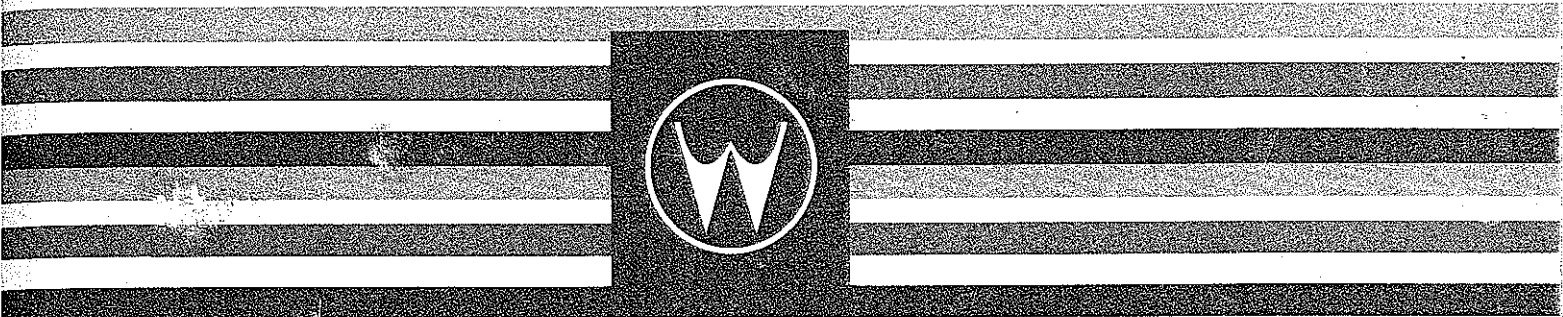

68P80309E56

COMMUNICATIONS SYSTEM ANALYZER