

Model TEK-1A

p/o CE2114



MODEL TEK-1A TONE GENERATOR

MODEL	TYPE OF MOUNTING
TEK-1A	SELF-CONTAINED IN STEEL HOUSING
TEK-28	PANEL MTD. FOR MTG. IN TU546, TU546P, S1056A OR S1057A PORTABLE TEST SETS

1. APPLICATION

These compact, battery-powered transistorized generators will deliver an approximate 400 or 1000 cps sine wave output of over two

volts with less than 10% distortion into an open circuit. When terminated in a resistive or inductive load of 500 ohms, the output will be greater than one volt. They can be used in a number of useful applications in servicing communications equipment such as: checking gain in receiver audio stages; checking modulation sensitivity in transmitter audio stages; providing a 1000 cps tone output for setting the transmitter IDC control; checking line losses in audio control lines; and other uses where a 400 or 1000 cps tone at one or two volts level may be required. The TEK-1A and TEK-28 Tone Generators are electrically identical.

2. USE OF THE TONE GENERATORS

The success of using the Tone Generator in trouble shooting a receiver or transmitter will depend a great deal upon your ability to know what to expect from such equipment under normal conditions. Only in this manner will you be able to interpret intelligently the results realized in some service problem. Thus, it is wise to take time to make these checks on at least one receiver and transmitter known to operate properly.

a. Operation

To turn on the tone generator, rotate the tone selector switch to either the 400 cycle or 1000 cycle position. The output voltage level is set by adjusting the level control. Output is available at both a three-circuit phone jack and pin jacks.

b. Test Cable

A test cable is provided for connecting the output of the generator to the input of a transmitter. The three-circuit phone plug connects to the tone generator. The other end of the cable is terminated with a microphone plug. Connection to a transmitter is made directly to the transmitter microphone receptacle or through a test set. When the tone generator is connected to a transmitter through the test cable, turning on the tone generator automatically keys the transmitter when the tone selector switch is in either the 400 or 1000 cycle position.

c. Calibrating the Generator Output

The output voltage of any generator will vary with the "load" into which it works. A lower re-

sistance termination becomes a "heavier" load for it allows more power to be taken from the generator. Also, due to "drops" within the generator, the output voltage from the generator will vary with the load. Thus, any calibrations made for the generator will be accurate only if used under the same load conditions.

If a low resistance such as 500 ohms is kept across the generator output at all times, the circuit into which the generator is connected will not change the total load to any noticeable degree and calibrations made for the generator will be more accurate. By taking readings for several settings of the output control and making a graph or chart from these readings, it is possible to know the generator output voltage for any setting of the control. Several such charts for different "loads" will give a reasonably accurate calibration for any condition under which you may use the generator and will eliminate the necessity of measuring the generator output every time it is used.

The output voltage of the generator will be less for a heavier load. Thus, if maximum output is desired, the load should be minimized as much as possible. Output voltage of the generator will also change with the battery voltage. A periodic check on either the output or the batteries will be advantageous. Replacing the batteries should not necessitate a change in calibration.

d. Checking The Audio Section of a Receiver

The dial of the tone generator can be calibrated to indicate an output level into a specific load by placing a high impedance a-c voltmeter across such a load. The meter reading in voltage corresponding to the tone generator dial setting will calibrate the dial in volts.

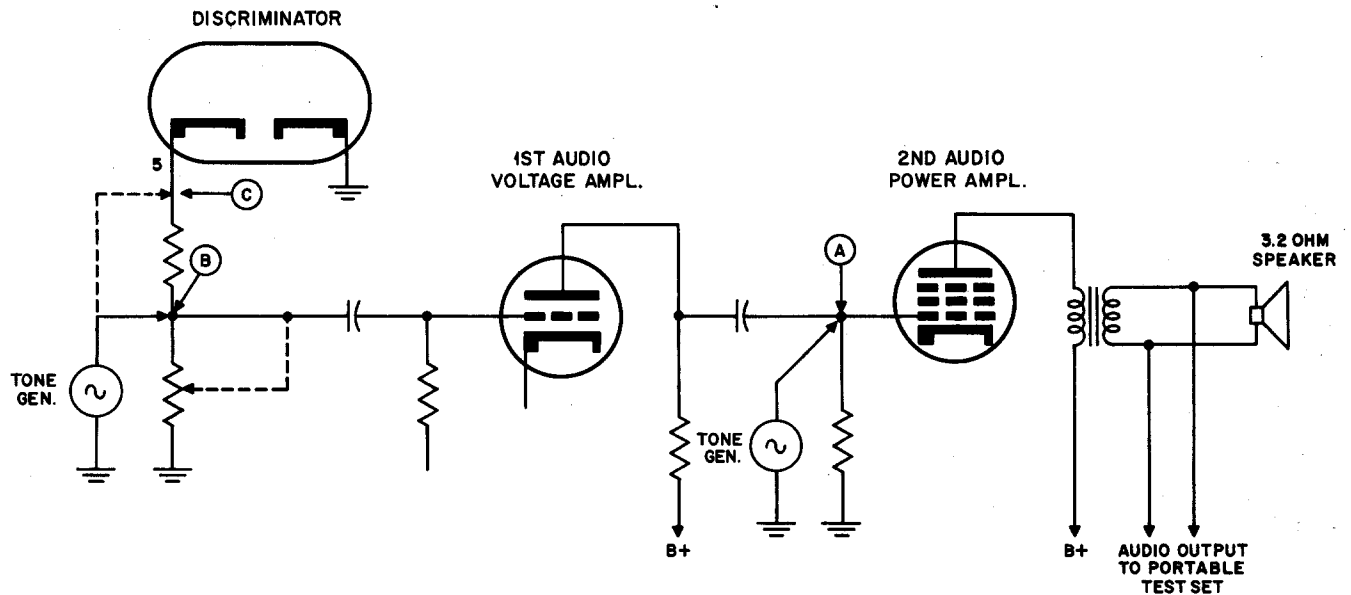

FIGURE 1
AUDIO SECTION, RECEIVER

In checking the audio output of a receiver, the tone generator output is applied to various points in the receiver audio stages, (see Fig. 1). The receiver output level is then indicated on the portable test set meter. This output voltage is a function of audio stage gain and its level is an indication that the audio stages of the receiver tested have normal gain or power output.

There may be some difference in the impedance of the speaker voice coil or meter of the portable test sets. For this reason it is recommended that the output level calibration be made on the particular test set used and any speaker external to the test set be disconnected during the test.

There may be different audio levels over the various receivers tested, therefore, any comparison of levels between receivers must be made on the same model or type of receiver.

Procedure for checking audio gain:

- (1) Insert the metering plug of the portable test set into the metering receptacle of the receiver.
- (2) Set the test set metering switch to the audio position. With the test set switch in this position the meter functions as an a-c voltmeter connected across the secondary of the audio output transformer.

- (3) Use a pair of clip-on test leads with pin tips on one end from the tone generator and connect one lead to ground and the other lead to the grid of the last (PA) audio stage of the receiver (point "A" in Fig. 1). Adjust the output of the tone generator to 2 volts. Note the reading on the test set meter. This reading will be an indication of audio output level.

- (4) Move the generator lead to the top of the grid type volume control or junction point "B" in Fig. 1. Set the squelch control to the unsquelched position and the volume control fully "on". Adjust the output of the tone generator to .5 volts. Note the meter reading on the test set. This reading will be an indication of output level developed from the amplification of the two audio stages.

- (5) Move the generator lead to the output of the discriminator (point "C" Fig. 1, pin 5 on 6AL5 discriminator tube socket). Adjust the output of the tone generator to 2 volts. Note the meter reading on the test set. This reading is an indication of level developed from the discriminator point.

In making measurements, take into consideration the many possible variations that may be encountered. Also, values that are typical for one receiver may not apply to another. As an example some communications receivers are designed to give an output of about 1 watt. Others however, will give two watts of audiopower. Stage measurements will vary for these receivers. When

comparisons are made they must always be applied to identical equipment or models.

e. Variations in Readings

For service work quick checks are possible for the "approximate" audio output, gain, etc. These may not be the complete information or the true values that might be realized under ideal and controlled conditions, but for service work they will suffice.

Figure 1 gives a common arrangement for the audio section of a communications receiver. Some models do not have a grid type volume control, and another point may be substituted for point "B".

f. Audio Measurements

In a receiver, the first audio stage is a voltage amplifier, while the last or output stage is a power amplifier. Thus, we are interested in the power gain of the last stage and the voltage gain of the first amplifier. In addition, a check may be made for the approximate power output.

g. Power Output

With the voltage known and an assumed impedance of 3 ohms for the voice coil, the power output can be calculated by the formula, $W = E^2/R$, where R is the voice coil impedance. With the S1056A-9A or TU546 Series Portable Test Sets, in position 11 (audio) the voltage is read directly on the red scale. With the P-8501 Portable Test Set in position 8, full scale deflection is approximately 2.5 volts. Divide the 0-50 scale markings by 20 to convert to voltage.

EXAMPLE

A 2-volt reading on the meter gives 4/3 or 1-1/3 watts.

Full power output cannot be realized unless the input voltage is sufficient to drive the output to full power. The tone generator must be moved to the grid of the first amplifier before maximum output can be realized.

h. Power Gain

To determine input power, the generator should be terminated in a 500-ohm load. Connect a 470 (500) ohm resistor across the generator leads and then connect to the grid of the last amplifier point ("A" Fig. 1). Adjust the generator

for an output of 1 volt at the grid. The input power is then 0.002 watts. Determine the power output. The ratio of this output to the input power is the power gain.

EXAMPLE

Output .08 watt \div input .002 watt = power gain 40.

i. Voltage Gain

To find the voltage gain of the first stage, apply a signal of .25 volts to point "B" Fig. 1. Leaving the generator connected, measure the a-c voltage at point "A" (across the grid resistor of the output stage). The ratio of the output voltage to the input is the approximate voltage gain of the stage at the frequency used.

EXAMPLE

Voltage out 5.0 volts \div voltage in .25 volts = voltage gain 20.

A reading of output levels at any stage which would be much less than normal would be an indication of a defect at that stage such as low gain tube, resistors or capacitors either open, shorted or off value. The above tests will determine the ability of the receiver audio stages to develop normal audio gain or power output. However, such tests do not prove the received signal will develop such audio amplification. The recovered audio of the receiver is also dependent on the output of the discriminator in accordance with the deviated carrier. The slope output of the discriminator can be checked for normal output by displacing the 455 kc carrier frequency, to which the discriminator is balanced, by ± 5 kc and noting the reading on the test set meter in position #4. An FM generator can also be used to check both the slope output of a discriminator and audiogain by applying a carrier frequency to the receiver modulated by ± 5 kc.

3. USING THE TONE GENERATOR IN THE TRANSMITTER

The generator was used to check both power levels and voltage gains in the receiver. At the transmitter it is used as a source of voltage to determine the modulation input level sensitivity and the point of clipper limiting.

Figure 2. gives the partial circuit of the audio stages in the transmitter. The specified input voltages for the various microphones are .18 and .25 volt at 1000 cps. The clipper prevents the

audio voltage from rising too high on peaks and over modulating the transmitter. This clipping action should start at the specified level of modulation sensitivity.

When the input audio voltage or its peaks exceed the modulation sensitivity level (.18 or .25 volts) the clipper will limit the output level to a constant value. The IDC control ("Instantaneous Deviation Control") can then be adjusted to provide the desired deviation. In normal practice the audio input voltage is set to a point well above the indicated clip level, +12 db or higher to insure full limiting at the clipper stage, then the IDC control is adjusted to effect the desired deviation of the transmitter carrier.

4. CHECKING THE AUDIO SECTION OF A TRANSMITTER

Connect the output of the tone generator to the microphone receptacle with the cable provided per the following instructions:

- Insert the phone plug into the tone generator jack.
- Insert the metal microphone plug into the microphone receptacle of the test set (if test set is used) or directly into a microphone receptacle on the control head or power supply.
- Connect a d-c voltmeter (Motorola DC Multi-meter or equivalent) to pin 2 of the 6AL5 clipper tube and ground. Key the transmitter by setting the toggle switch to the "on" position. Increase the tone output until the meter reading just begins to

drop off. Connect an a-c voltmeter (Motorola Transistorized AC Voltmeter or equivalent) to the output leads of the tone generator connected to the microphone receptacle pins 1 and 2. Measure the input voltage at this point. A reading of .25 volt ± 3 db for input sensitivity tap at the .25 volt point (#1, Fig. 2) or a reading of .18 volts ± 3 db if sensitivity tap is at .18 volt point (#2, Fig. 2) is an indication of normal gain at this point. Readings higher than these would indicate low audio gain and difficulty would be experienced in modulating the transmitter properly with normal voice level. The low gain may be caused by low gain tubes, low voltages or defective component parts.

- Setting the deviation control: If the above test indicates normal audio gain, adjust the output of the tone generator to the 1 volt level as indicated on the a-c voltmeter or previously calibrated dial position. Then adjust the IDC control in accordance with the 5 kc indication on the particular modulation meter used. Inability to obtain a reading of 5 kc on a suitably calibrated deviation meter would be an indication of a weak or defective tube in the amplifier following the clipper stage or the modulator, low voltages, or defective component parts.

5. CHECKING LINE LOSSES OF AUDIO CONTROL LINES

Remote control lines are used to connect the remote microphone amplifier to the transmitter.

The line loss (at the tone generator frequency of 400 or 1000 cycles) can be determined by

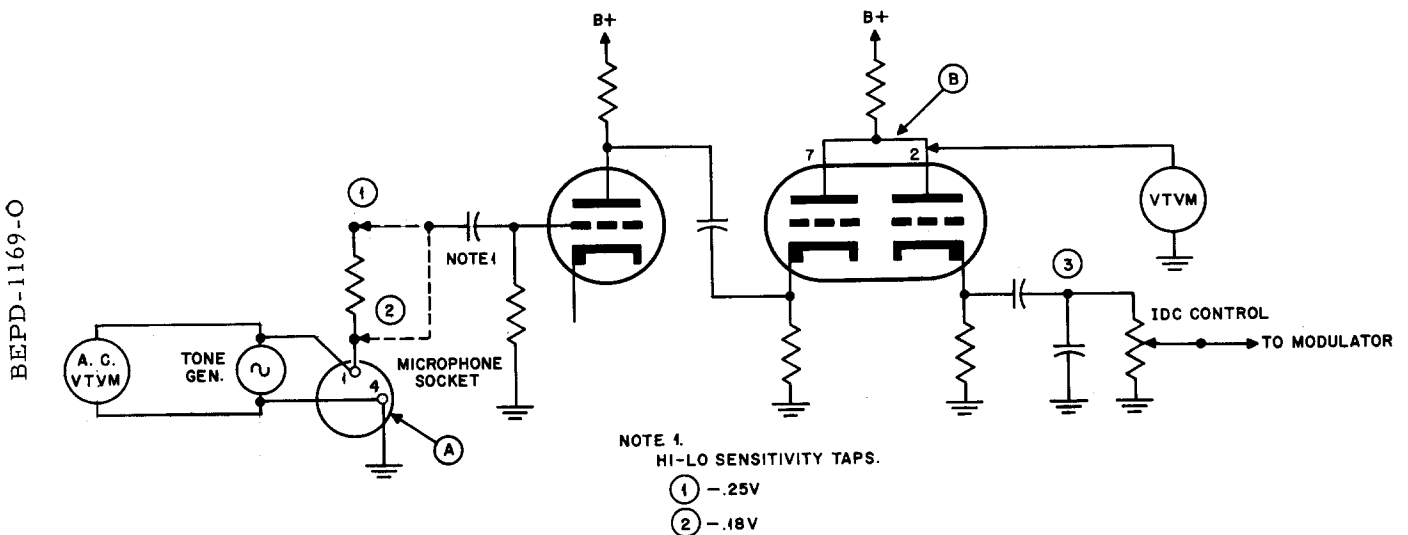

FIGURE 2
AUDIO SECTION, TRANSMITTER

making a voltage measurement at the remote point of the line and the opposite or terminating end of the line. A 400 or 1000 cycle tone of 1 volt (as measured on a high impedance a-c voltmeter) is applied to the line at the remote console. The a-c voltmeter is then moved to the transmitter end of the line and a reading is taken at this point. The ratio of the remote console line voltage to the transmitter end line voltage would be the line loss in db.

EXAMPLE

The voltage at the remote end (1 volt) divided by the voltage at the transmitter end (.25 volts) = a voltage ratio of 4:1 or 12 db. The indicated line loss would be 12 db.

The insertion loss of a P-8066 Series Remote Control Chassis at the base station can also be checked in the following manner: Remove the remote line from terminals 7 & 8 bottom row of the (P-8066) panel. Remove the power from the transmitter. Connect the output leads of the tone generator to terminals 7 & 8 bottom row. Place an a-c voltmeter on terminals 6 and 8 of the top row. Turn the line input control to the full on position.

Press the keying relay manually. Adjust the output of the tone generator to a maximum indication on the meter. Record the meter reading. Move the a-c voltmeter leads to terminals 7 and 8 bottom row and note the meter reading. The difference of the two readings in volts is the ratio of input to output voltage through the remote panel or the insertion loss between the input and output terminals.

EXAMPLE

Volts input at terminals 7 and 8 bottom row = 1 volt divided by volts output measured at terminals 6 and 8 top row = .8 volts. The ratio of input to output voltage = 1.25:1 or approximately 2 db.

For all remote panels with input and output impedance of the same order, the insertion loss should not exceed 2 db for a normal unit.

For remote panels with different input and output impedances, the voltage ratios must be calculated in accordance with the value of the impedances encountered. However, the tests can be made on a basis of comparison of levels with similar model or type of units known to be working properly.

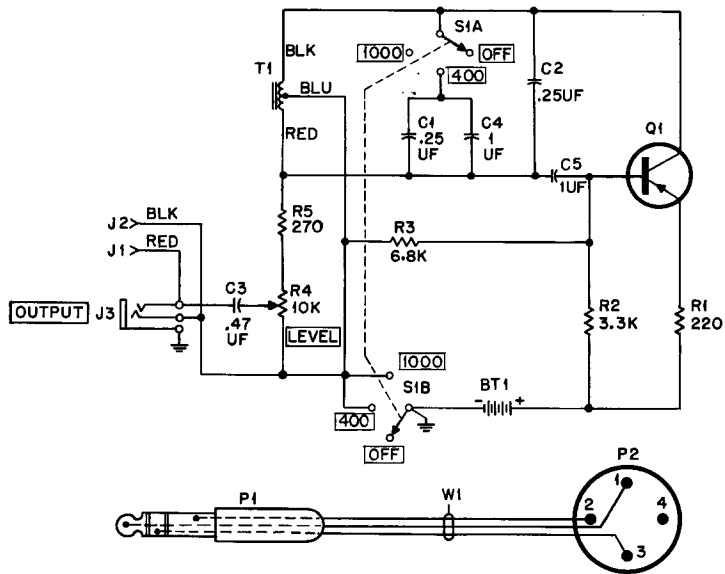

DIAGRAM NO. 63B81101A92

PARTS LIST for Schematic Diagram 63B81101A92-A

REFERENCE SYMBOL	MOTOROLA PART NO.	DESCRIPTION
BT1	60A82282C01	<u>BATTERY:</u> dry; 9 v See note
C1, 2	8K834384	<u>CAPACITOR, fixed:</u> uuf, unl stated 0.25 uf ±20%; 200 v
C3	8K863028	0.47 uf ±10%; 200 v
C4, 5	8K863306	1.0 uf ±10%; 200 v
J1	9K833983	<u>CONNECTOR, receptacle:</u> female; single contact; RED
J2	9A833982	female; single contact; BLK
J3	9A82281B01	<u>JACK, telephone:</u> 3 contact, open circuit
P1	28K855278	<u>PLUG, telephone:</u> 3 contact; RED
P2	28A163370	<u>CONNECTOR, plug:</u> male; 4 contact
Q1	48A134400	<u>TRANSISTOR, (NOTE 1)</u> P-N-P
R1	6R6270	<u>RESISTOR, fixed: ±10%; 1/2 w;</u> unl stated 220
R2	6R5581	3.3K
R3	6R6428	6.8K
R4	18D890193	var; 10K ±10%; 2 w
R5	6R6432	270
S1	40K801196	<u>SWITCH,</u> 4 pole; 3 position: c/o
S1A		2 pole, 3 position
S1B		2 pole, 3 position
T1	25B848522	<u>TRANSFORMER, audio:</u> single winding; RED, BLK with BLU tap
W1	30B844810	<u>CABLE shielded</u> 2 conductor, 3 ft. req'd.
NON-REFERENCED ITEMS		
	36A855027	KNOB, control for S1
	36A863918	KNOB, control; for R4
	31R121813	TERMINAL STRIP, 5 terminals
	42K801125	CLIP, battery
	39K644719	CLIP, and leads

REVISIONS

DIAG. ISSUE	CHASSIS AND SUFFIX NO.	REF. SYMBOL	CHANGE	LOCATION
A	TEK-1A & TEK-28	R5	ADDED	R4 POTENTIO-METER

Note: The battery used by this Test Set is a common 9-volt "transistor" battery, unlike similar Motorola Test Sets, which use 6.75 or 7.0 volt mercury batteries.

NOTE:

1. Replacement transistors of crystal units (diodes) must be ordered by Motorola part number only for optimum performance.

END OF DOCUMENT

Transistor Tone Generator
Schematic Diagram
Motorola No. 63B81101A92-A
3/4/64-UP