

DEPARTMENT OF THE ARMY TECHNICAL MANUAL

DEPARTMENT OF THE AIR FORCE TECHNICAL ORDER

^{Try}
TM11-5030A
T016-35TS497-7

SIGNAL GENERATOR

TS-497B/URR



DEPARTMENTS OF THE ARMY AND THE AIR FORCE

OCTOBER 1953

TECHNICAL MANUAL
 No. 11-5030A
 TECHNICAL ORDER
 No. 16-35TS497-7

DEPARTMENTS OF THE ARMY AND
 THE AIR FORCE
 WASHINGTON 25, D. C., 13, October 1953.

SIGNAL GENERATOR TS-497B/URR

	<i>Paragraphs</i>	<i>Page</i>
CHAPTER 1. INTRODUCTION		
Section I. General.....	1, 2	7
II. Description and data.....	3-8	7
CHAPTER 2. OPERATING INSTRUCTIONS		
Section I. Service upon receipt of Signal Generator TS-497B/URR.....	9-11	11
II. Controls and instruments.....	12, 13	14
III. Operation under usual conditions.....	14-17	15
CHAPTER 3. ORGANIZATIONAL MAINTENANCE INSTRUCTIONS		
Section I. Organizational tools and equipment.....	18, 19	19
II. Preventive maintenance service.....	20-23	19
III. Lubrication and weatherproofing.....	24, 25	22
IV. Troubleshooting at organizational maintenance level.....	26-29	23
CHAPTER 4. THEORY.....	30-37	26
5. FIELD MAINTENANCE INSTRUCTIONS		
Section I. Prerepair procedures.....	38-42	35
II. Troubleshooting at field maintenance level.....	43-49	36
III. Repairs.....	50-57	40
IV. Calibration procedure.....	58-62	45
CHAPTER 6. SHIPMENT AND LIMITED STORAGE AND DEMOLITION TO PREVENT ENEMY USE		
Section I. Shipment and limited storage.....	63, 64	47
II. Demolition of materiel to prevent enemy use.....	65, 66	47
APPENDIX I. REFERENCES.....		48
II. IDENTIFICATION TABLE OF PARTS.....		49
INDEX.....		57

WARNING

HIGH VOLTAGE

is used in the operation of
this equipment.

DEATH ON CONTACT

may result if operating personnel
fail to observe safety precautions.

ARTIFICIAL RESPIRATION

GENERAL PRINCIPLES

1. Seconds count! Begin at once! Don't take time to move the victim unless you must. Don't loosen clothes, apply stimulants or try to warm the victim. Start resuscitation! Get air in the lungs! You may save a life!

2. Place the victim's body in a prone position, so that any fluids will drain from the respiratory passages. The head should be extended and turned sideward *never flexed forward*; the chin shouldn't sag, since obstruction of the respiratory passages may occur.

3. Remove any froth or debris from the mouth with your fingers. Draw the victim's tongue forward.

4. Begin artificial respiration. Continue it rhythmically and without any interruption until natural breathing starts or the victim is pronounced dead. Try to keep the rhythm smooth. Split-second timing is not absolutely essential.

5. When the victim starts breathing, or when additional help is available loosen the clothing; remove it, if it's wet; keep the victim warm. Shock should receive adequate attention. Don't interrupt the rhythmical artificial technique for these measures. Do them only when you have help or when natural breathing has started.

6. When the victim is breathing, adjust your timing to assist him. Don't fight his efforts to breathe. Synchronize your efforts with his. After resuscitation, keep him lying down until seen by a physician or until recovery seems certain.

7. Don't wait for mechanical resuscitation! If an approved model is available, use it, but, since mechanical resuscitators are only slightly more effective than properly performed "push-pull" manual technique. *never* delay manual resuscitation for it.

BACK-PRESSURE ARM LIFT METHOD

1. *Position of Victim.* Place the victim in the prone (face-down) position. Bend his elbows; place one hand upon the other. Turn his face to one side, placing his cheek upon his hands.

2. *Position of Operator.* Kneel on your left or right knee, at the victim's head, facing him. Your knee

should be at the side of the victim's head close to his forearm, your foot should be near his elbow. Kneel on both knees if you find it more comfortable, with one knee on each side of the head. Place your hands on the flat of the victim's back so that their heels are just below the lower tip of his shoulder blades. With the tip of your thumbs touching spread your fingers downward and outward. (See A)

3. *Compression Phase.* Rock forward until your arms are approximately vertical and allow the weight of the upper part of your body to exert a slow, steady, even, downward pressure upon your hands. This forces air out of the lungs. Keep your elbows straight and press almost directly downward on the back. (See B)

4. *Expansion Phase.* Release the pressure, avoid any finish thrust, and commence to rock backward slowly. Place your arms upon the victim's arms just above the elbows, and draw his arms upward and toward you. Apply just enough lift to feel resistance and tension at the victim's shoulders.

Don't bend your elbows. As you rock backward, the victim's arms will be drawn toward you. (The arm lift expands the chest by pulling on the chest muscles, arching the back and relieving the weight on the chest.) Drop the arms gently to the ground or floor. This completes the cycle. (See C and D). Now repeat the cycle.

5. *Cycle Timing and Rhythm.* Repeat the cycle 10 to 12 times per minute. Use a steady uniform rate of Press, Release, Lift, Release. Longer counts of about equal length should be given to the "Press" and "Lift" steps of the compression and expansion phases. Make the "Release" periods of minimum duration.

6. Changing Position or Operator.

(a) Remember that you can use either or both knees or can shift knees during the procedure, provided you don't break the rhythm. Observe how you rock forward with the back-pressure and backward with the arm-lift. The rocking motion helps to sustain the rhythm and adds to the ease of operation.

(b) If you tire and another person is available, you can "take turns." Be careful not to break the rhythm in changing. Move to one side and let your replacement come in from the other side. Your replacement begins the "Press-Release" after one of the "Lift-Release" phases, as you move away.

TM AR-3

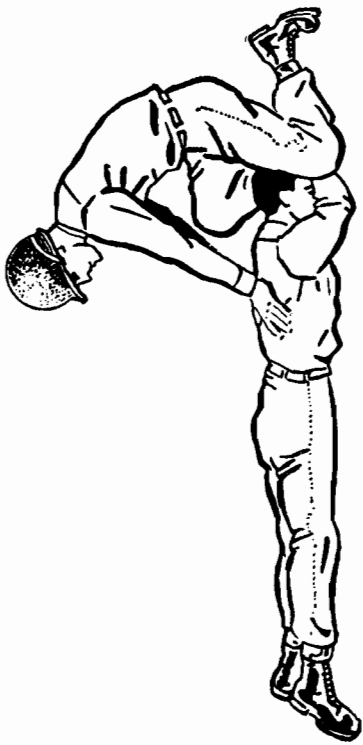

A Position of operator and victim

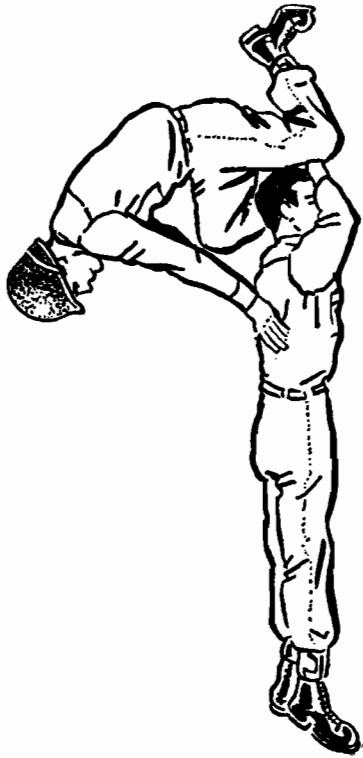

B Compression phase

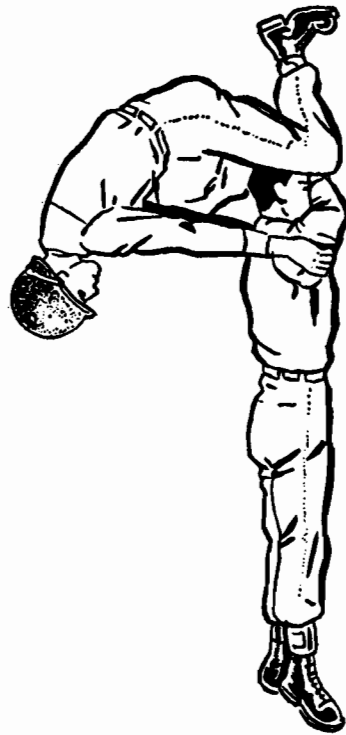

C Expansion phase (arm lift)

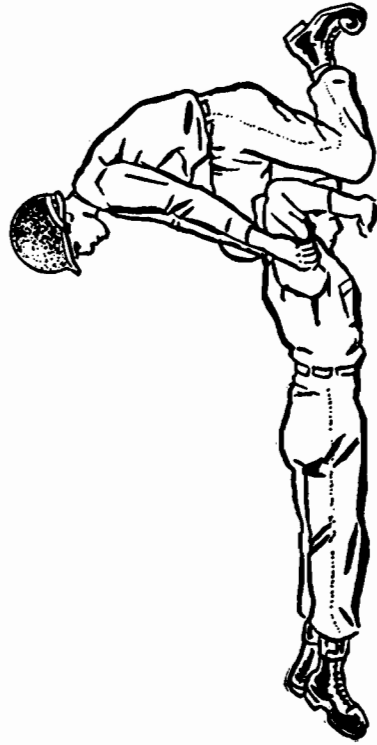

D Expansion phase (arm release)

TMAR-4

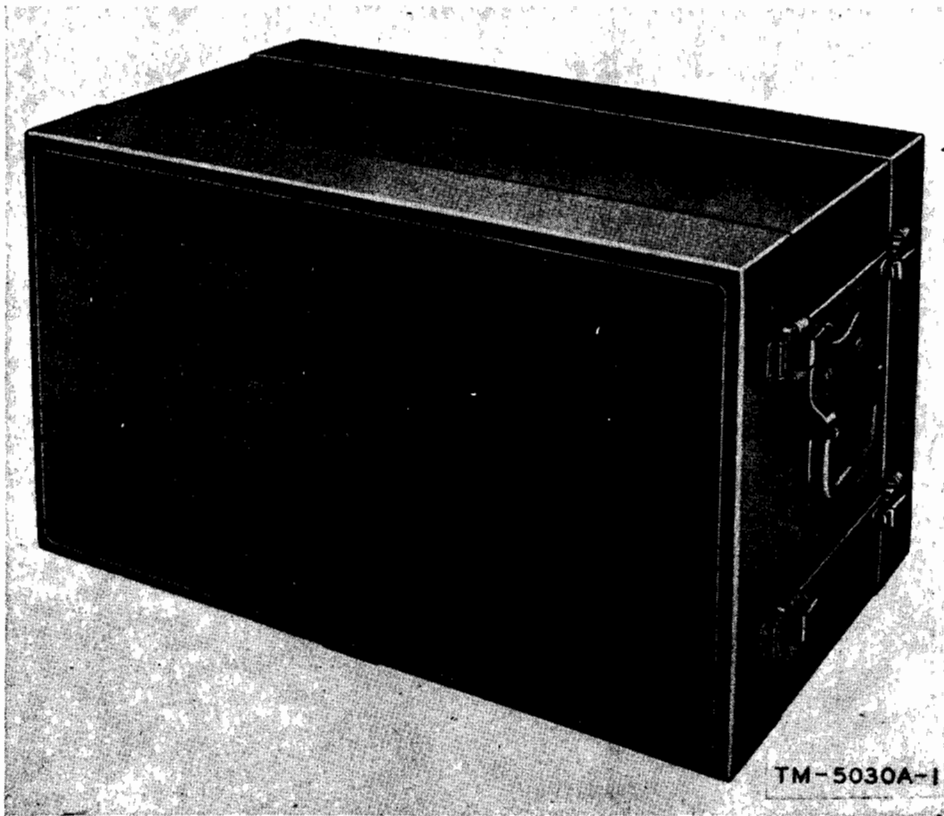

Figure 1. Signal Generator TS-497B/URR, outside view.

CHAPTER 1

INTRODUCTION

Section I. GENERAL

1. Scope

This manual is published for the information and guidance of the personnel to whom this equipment is issued. It includes instructions for the installation, operation, maintenance, and repair of Signal Generator TS-497B/URR. In addition to these instructions there are two appendixes covering a list of references and an identification table of parts.

2. Forms and Records

The following forms will be used for reporting unsatisfactory conditions of Army equipment and in performing preventive maintenance.

a. DD Form 6, Report of Damaged or Improper Shipment, will be filled out and forwarded as prescribed in SR 745-45-5 (Army), Navy Shipping Guide, Article 1850-4, and AFR 71-4 (Air Force).

b. DA Form 468, Unsatisfactory Equipment Report, will be filled out and forwarded to the Office of the Chief Signal Officer, as prescribed in SR 700-45-5.

c. AF Form 54, Unsatisfactory Report, will be filled out and forwarded to Commanding General, Air Materiel Command, Wright-Patterson Air Force Base, Dayton, Ohio, as prescribed in SR 700-45-5 and AFR 65-26.

d. DA AGO Form 11-238, Operator First Echelon Maintenance Check List for Signal Corps Equipment (Radio Communication, Direction Finding, Carrier, Radar), will be prepared in accordance with instructions on the back of the form.

e. DA AGO Form 11-239, Second and Third Echelon Maintenance Check List for Signal Corps Equipment (Radio Communication, Direction Finding, Carrier, Radar), will be prepared in accordance with instructions on the back of the form.

f. Use other forms and records as authorized.

Section II. DESCRIPTION AND DATA

3. Purpose and Use

a. Signal Generator TS-497B/URR (fig. 1) is a portable unit which provides r-f (radio-frequency) test signals over a range of 2 to 400 mc (megacycles) in six bands.

b. The instrument is designed primarily for use in making the precise measurements required in the maintenance of radio equipment.

c. The signal generator provides a sine-wave a-m (amplitude-modulated) r-f signal. Provision is made for the use of an external sine-wave generator having an output between 7 and 10 volts within the frequency range from 50 to 10,000 cps (cycles per second). An input jack is provided for pulse modulation from an external source. The pulse generator should provide a minimum of 150 volts peak.

4. Technical Characteristics

Frequency range :

Band A.....	2 mc to 5 mc.
Band B.....	5 mc to 13 mc.
Band C.....	13 mc to 30 mc.
Band D.....	30 mc to 78 mc.
Band E.....	78 mc to 180 mc.
Band F.....	180 mc to 400 mc.

Accuracy of frequency calibrations. ± 0.5 percent on all ranges.

Output impedance..... Approximately 50 ohms.

Percent modulation (sine wave). 0 to 30 percent.

Internal modulation..... 400 or 1,000 cps.

External modulation :

Sine wave..... 50 to 10,000 cps, 7 to 10 volts, rms (root mean square).

Pulse..... 150 volts peak minimum.

Input voltage..... 117 volts, 50/60 cycles.

Power input..... 65 watts

Carrier output----- Continuously variable 0.1 to 100,000 μv (microvolts) (50,000 μv when used with attenuator pad). (Attenuator leakage is less than 0.1 μv and the stray field is less than 0.2 μv at any point outside the case.)

Number of tubes----- 8.

Number of crystals----- 2.

Weight----- 57 pounds.

5. Packaging Data

Signal Generator TS-497B/ URR is packaged in a moisture-vaporproof container and packed in a wooden shipping container. Figure 4 shows a typical equipment packed for export. The packed equipment weighs approximately 75 pounds and has a volume of 3.5 cubic feet. For

export shipment, the box is bound with two metal straps.

6. Table of Components

Component	Re-quired No.	Height (in.)	Depth (in.)	Length (in.)	Vol-ume (cu ft)	Unit weight (lb)
Signal Generator TS-497B/URR---	1	11 $\frac{1}{2}$	11 $\frac{1}{2}$	20 $\frac{1}{2}$	1.61	54.7
Cord CG-55B/U----	1			50		.75
RF Cable Assembly CG-683/U-----	1			50		.25
Fixed attenuator Z1	1	1	1	3 $\frac{1}{2}$.3
Set of running spares	1					1
Technical manual	2					
Total-----					1.61	57

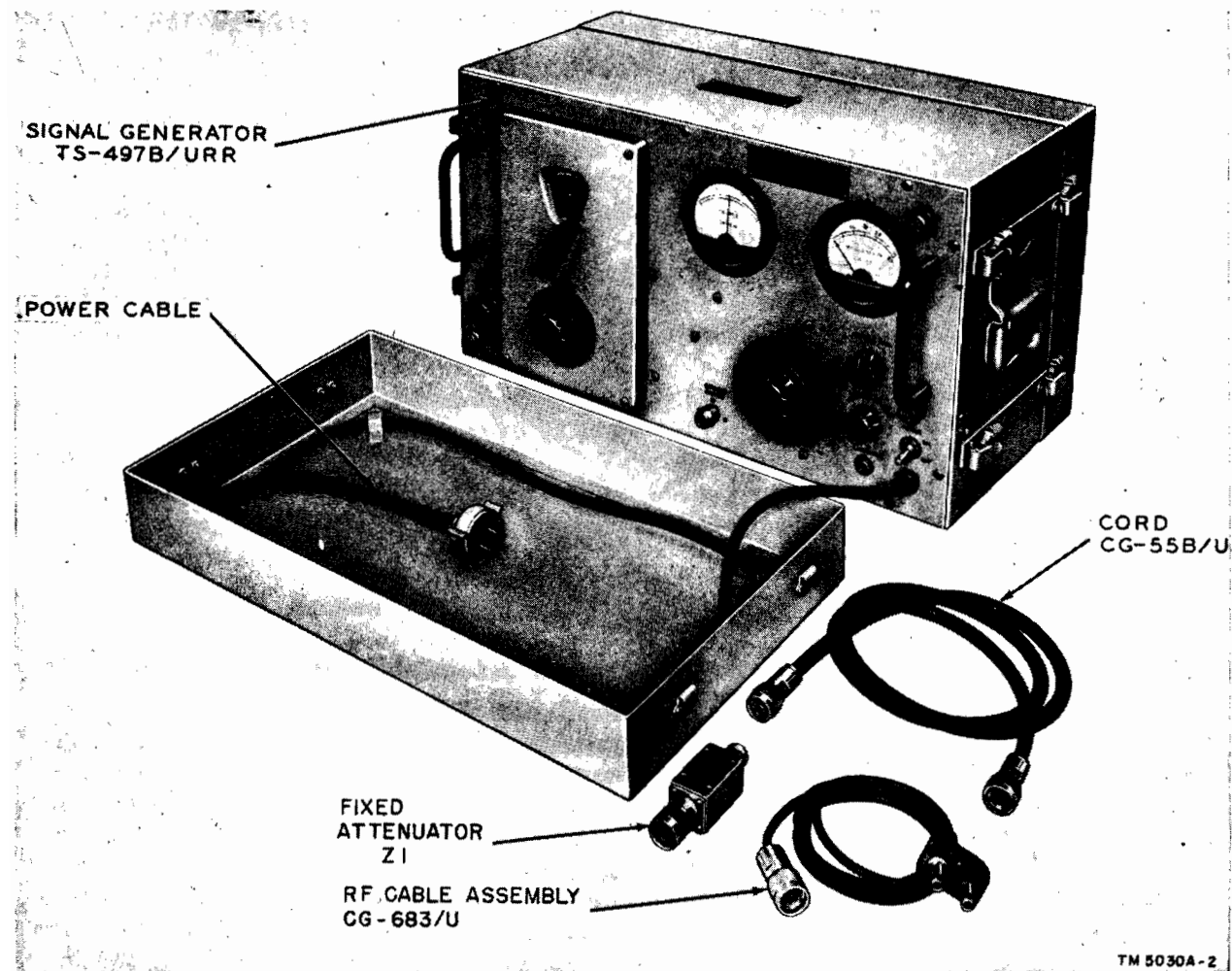

Figure 2. Signal Generator TS-497B/URR, front view.

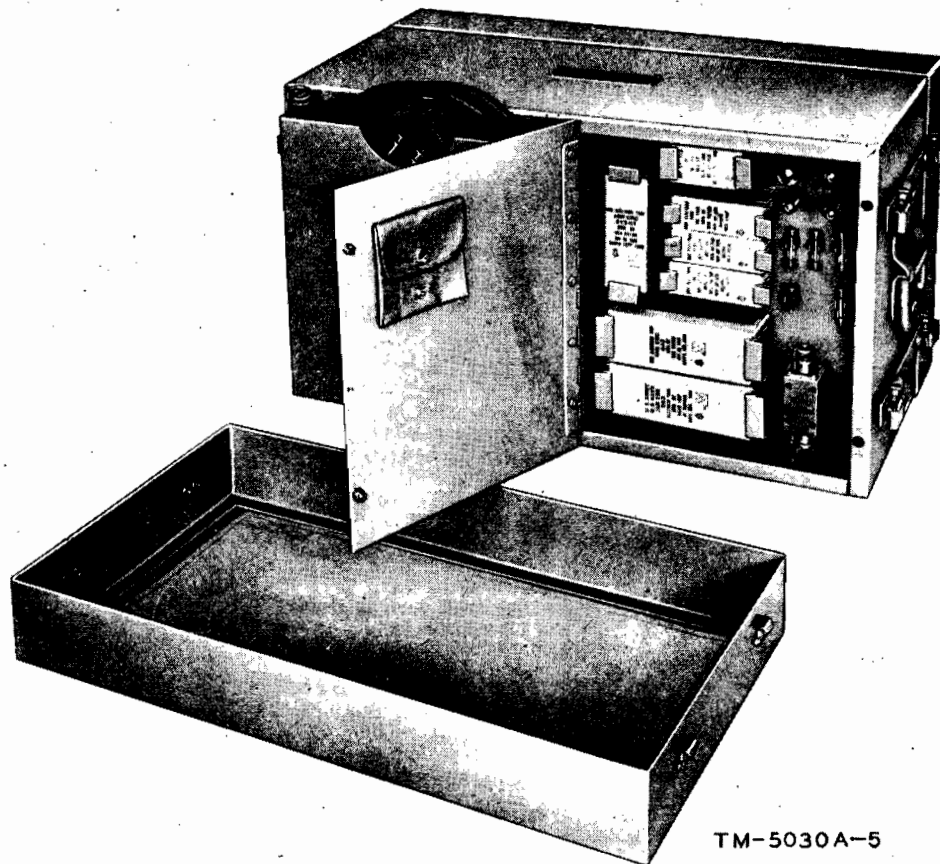

Figure 3. Signal Generator TS-497B/URR, rear view.

7. Description of Signal Generator

a. The signal generator consists of a panel chassis assembly (fig. 17) contained in a steel case. The case is equipped with two carrying handles and four protective feet. The front and rear of the case are protected by two covers held in place by spring catches. Steel runners are located in the bottom of the case to permit easy removal of the chassis. The a-c (alternating-current) power cord attached to the chassis is accessible from the front of the generator. When the equipment is packed for shipping, the plug on the end of the cord is secured to the front cover by a clip.

b. All controls and assemblies of the signal generator are mounted on the front panel. The guard handles on each side of the front panel (fig. 2) provide means for removing the unit from the case and also serve as a protecting support for the meters and controls when the unit is rested on the front panel for servicing.

c. A drum assembly, located to the left of the power supply chassis on the back of the front panel, contains the carrier oscillator (fig. 17). The assembly consists of an inner and an outer drum, each having a cover shield. A grounding wiper is fastened on the inside of the inner shield. Three clamps secure the outer shield to the drum.

d. The case is designed so that all components, spare parts, and an Allen wrench case are housed within the case. A circuit label is located inside the rear cover of the case.

e. The following components are supplied with Signal Generator TS-497B/URR (fig. 2):

- (1) Cord CG-55B/U, consisting of a 4-foot length of Radio Frequency Cable RG-8A/U terminated with a Radio Frequency Plug UG-21B/U at each end.
- (2) RF Cable Assembly CG-683/U, consisting of a 4-foot length of Radio Frequency Cable RG-58C/U terminated

with Plug Connector UG-536/U at one end and two binding posts and a 52.5-ohm termination in a metal housing at the other end.

- (3) An impedance-matching pad, fixed attenuator Z1, which consists of a 50-ohm resistive network mounted in a cast-aluminum housing, terminated at the input end with Radio Frequency Plug UG-21B/U, and at the output end with Radio Frequency Receptacle UG-58/U. It provides an attenuation of 6 db (decibels).
- (4) An Allen wrench set (fig. 3).

8. Running Spares

The following running spares (fig. 3) are supplied with each signal generator:

- 1 lamp, 3 watts, 120 volts, GE #S-6.
- 3 Lamps LM-27.
- 5 fuses, 1 ampere, Buss type AGC.
- 1 tube type 6AQ5.
- 1 tube type 0A3/VR75.
- 1 tube type 5Y3GT.
- 1 tube type 0C3/VR105.
- 1 tube type 6AU6.
- 1 tube type 12AU7.
- 1 crystal rectifier 1N21B.
- 1 tube type 955.

CHAPTER 2

OPERATING INSTRUCTIONS

Section I. SERVICE UPON RECEIPT OF SIGNAL GENERATOR TS-497B/URR

9. Uncrating and Unpacking New Equipment

Note. For used or reconditioned equipment, refer to paragraph 11.

a. General. Signal Generator TS-497B/URR is packed in a wooden box. When new equipment is received, select a location where the equipment may be unpacked without exposure to dust, dirt, or excessive moisture. Use tools carefully; the equipment may be damaged if tools are thrust into the interior of the shipping container.

b. Step-By-Step Instructions for Uncrating and Unpacking (fig. 4).

- (1) Place the packing case as near the operating position as convenient.
- (2) Cut and fold back the steel straps.
- (3) Remove the nails with a nail puller. Remove the top cover.
- (4) Remove the waterproof metal container and any filler material.
- (5) Open the four flaps on the top of the inner corrugated container.
- (6) Remove the equipment from its inner container and place it on the workbench.
- (7) Inspect the equipment for possible damage incurred during shipment.

Note. Save the original packing cases and containers. They may be used again when the equipment is repacked for storage or shipment.

10. Inspecting New Equipment

a. Remove the 10 screws that hold the front panel to the case. Carefully slide the signal generator out of the case.

b. See that all tubes (except V11) are seated firmly in their proper sockets on the chassis (fig. 9). *Do not check tube V11 which is located within the carrier oscillator drum shield.*

c. Check the fuses for the proper rating (1 amp.). They are shipped in the fuseholders. The fuseholder at the upper right-hand corner of the panel (fig. 5) is for a spare fuse.

d. Rest the signal generator on the guard handles. Check the equipment for broken wires or loose connections.

e. Reassemble the unit in the case. Check the operation outlined in paragraph 14. The signal generator is portable, and may be placed in any location convenient to the equipment to be tested.

11. Service Upon Receipt of Used or Reconditioned Equipment

a. Follow the instructions in paragraph 9 for uncrating, unpacking, and checking the equipment.

b. Check the used or reconditioned equipment for tags or other indications pertaining to wiring changes. If wiring changes have been made, note the changes in this manual, preferably on the schematic diagram.

c. Inspection and operational checks will be the same as those outlined for new equipment.

CHAPTER 2

OPERATING INSTRUCTIONS

Section I. SERVICE UPON RECEIPT OF SIGNAL GENERATOR TS-497B/URR

9. Uncrating and Unpacking New Equipment

Note. For used or reconditioned equipment, refer to paragraph 11.

a. General. Signal Generator TS-497B/URR is packed in a wooden box. When new equipment is received, select a location where the equipment may be unpacked without exposure to dust, dirt, or excessive moisture. Use tools carefully; the equipment may be damaged if tools are thrust into the interior of the shipping container.

b. Step-By-Step Instructions for Uncrating and Unpacking (fig. 4).

- (1) Place the packing case as near the operating position as convenient.
- (2) Cut and fold back the steel straps.
- (3) Remove the nails with a nail puller. Remove the top cover.
- (4) Remove the waterproof metal container and any filler material.
- (5) Open the four flaps on the top of the inner corrugated container.
- (6) Remove the equipment from its inner container and place it on the workbench.
- (7) Inspect the equipment for possible damage incurred during shipment.

Note. Save the original packing cases and containers. They may be used again when the equipment is repacked for storage or shipment.

10. Inspecting New Equipment

a. Remove the 10 screws that hold the front panel to the case. Carefully slide the signal generator out of the case.

b. See that all tubes (except V11) are seated firmly in their proper sockets on the chassis (fig. 9). *Do not check tube V11 which is located within the carrier oscillator drum shield.*

c. Check the fuses for the proper rating (1 amp.). They are shipped in the fuseholders. The fuseholder at the upper right-hand corner of the panel (fig. 5) is for a spare fuse.

d. Rest the signal generator on the guard handles. Check the equipment for broken wires or loose connections.

e. Reassemble the unit in the case. Check the operation outlined in paragraph 14. The signal generator is portable, and may be placed in any location convenient to the equipment to be tested.

11. Service Upon Receipt of Used or Reconditioned Equipment

a. Follow the instructions in paragraph 9 for uncrating, unpacking, and checking the equipment.

b. Check the used or reconditioned equipment for tags or other indications pertaining to wiring changes. If wiring changes have been made, note the changes in this manual, preferably on the schematic diagram.

c. Inspection and operational checks will be the same as those outlined for new equipment.

NOTE: FOLLOW PROCEDURE OUTLINED IN STEPS 1 THROUGH 5 ONLY FOR DOMESTIC SHIPMENTS.
ADD STEPS 7 AND 8 FOR OVERSEAS SHIPMENTS.

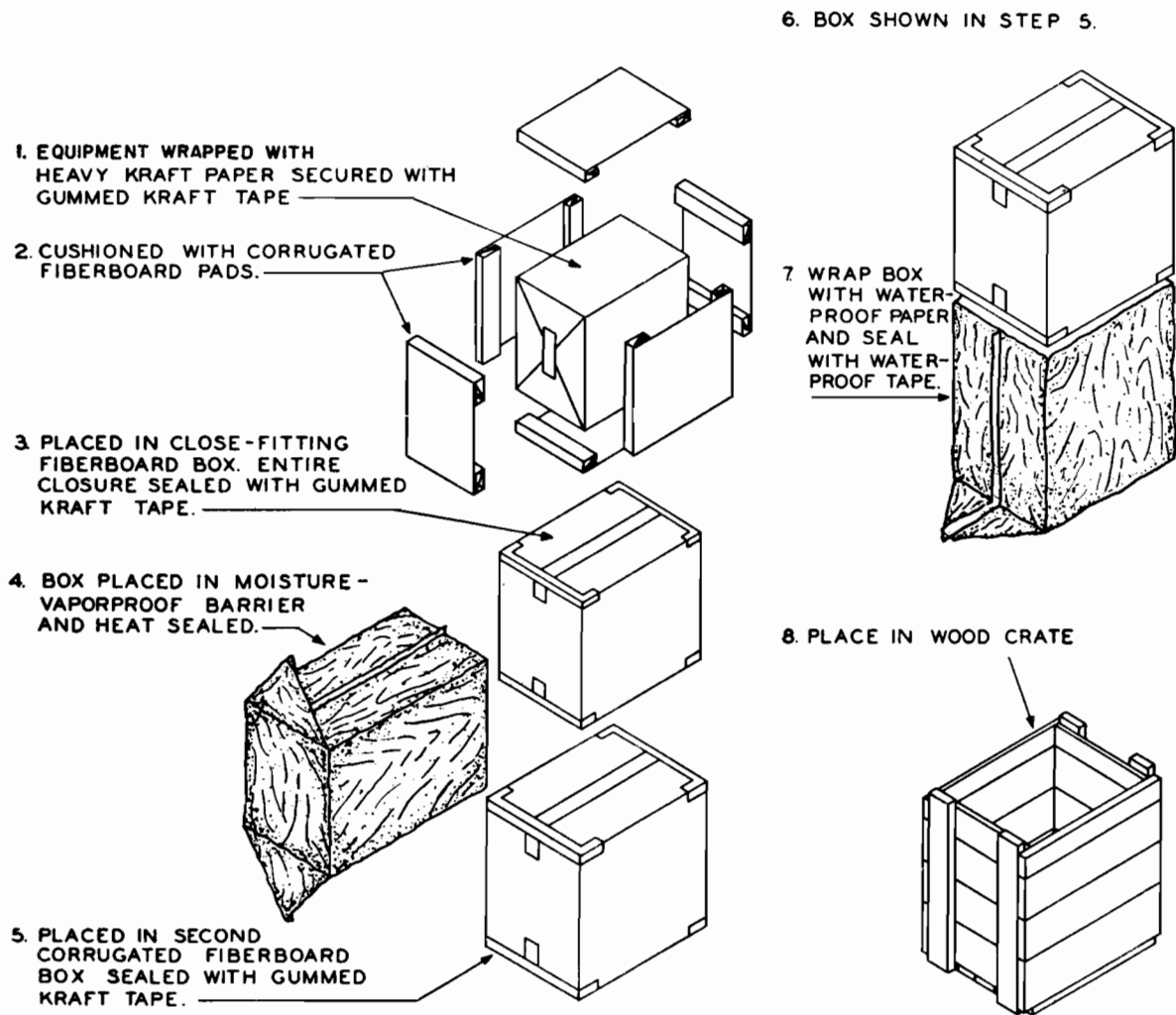

Figure 4. Typical packaging for export shipment.

TM 1242-5

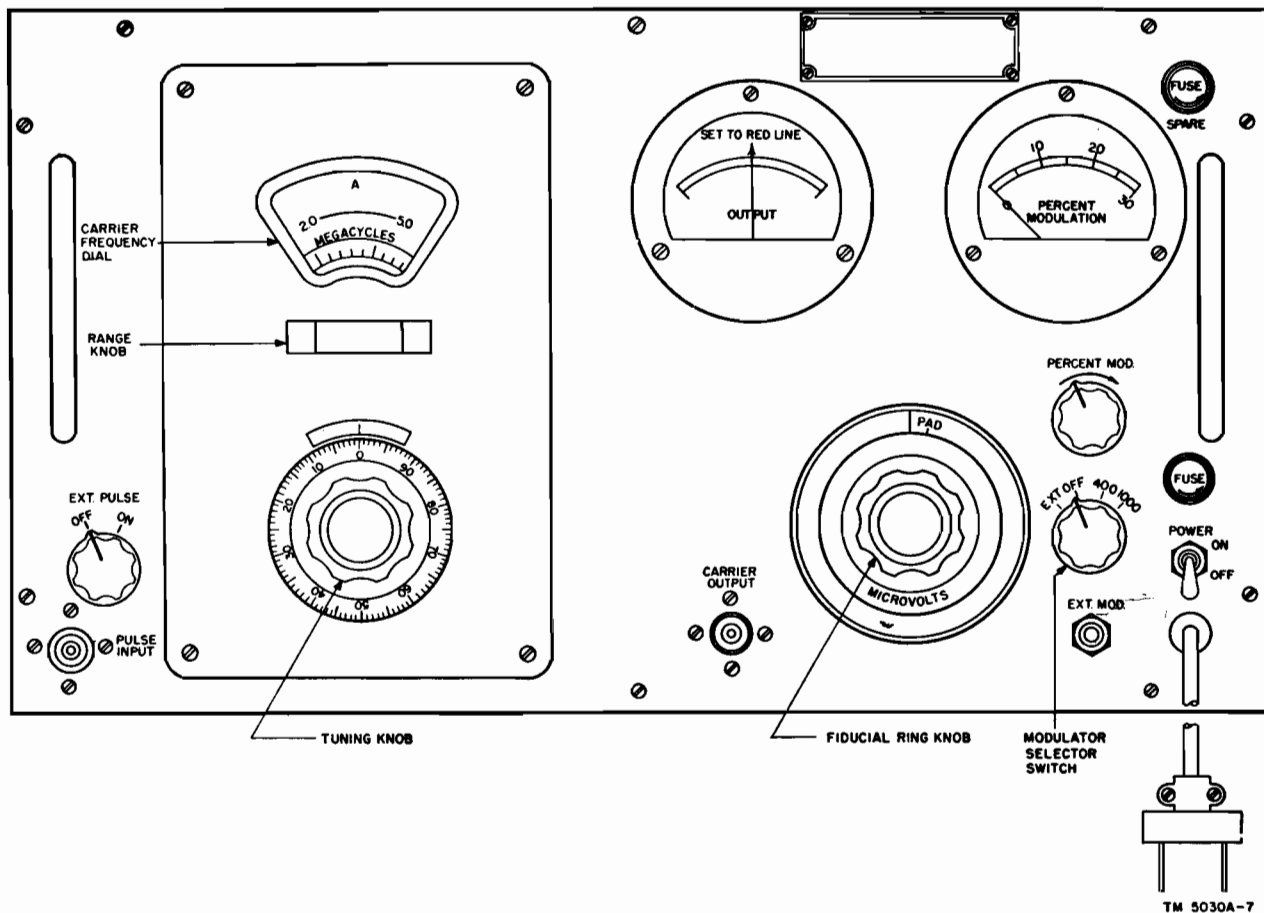

Figure 5. Signal Generator TS-497B/URR, front panel.

Section II. CONTROLS AND INSTRUMENTS

12. Controls and Instruments and Their Uses (fig. 5)

Haphazard operation or improper setting of the controls may cause damage to electronic equipment. For this reason, it is important to know the function of every control. The actual operation of the equipment is discussed in paragraphs 14 through 17. The following table lists the controls and instruments of the signal generator and indicates their functions:

Control or instrument	Function
Range knob-----	Selects desired frequency band and operates a mask to conceal dial markings on bands not in use. The various bands are: Band A: 2 mc to 5 mc. Band B: 5 mc to 13 mc. Band C: 13 mc to 30 mc. Band D: 30 mc to 78 mc. Band E: 78 mc to 180 mc. Band F: 180 mc to 400 mc.
Carrier frequency dial---	Indicates carrier frequencies for each of six frequency bands. Divisions of carrier frequency dial are spaced as follows: Band A: Every 100 kc (kilocycles) with numbered frequencies indicated at every half mc. Band B: Every 200 kc with numbered frequencies indicated at every mc. Band C: Every 200 kc to 20 mc, every 500 kc from 20 to 30 mc, with numbered frequencies indicated at every mc. Band D: Every 1 mc with numbered frequencies indicated at every 5 mc. Band E: Every 2 mc with numbered frequencies indicated at every 10 mc. Band F: Every 5 mc with numbered frequencies indicated at every 10 mc.
Tuning knob (C12)-----	Selects desired frequency on carrier frequency dial. When disengaged from carrier frequency dial, tuning knob can be reset to read 0. In this

Control instrument	Function
PERCENT MODULATION meter (M2). PERCENT MOD. knob (R33). Modulation selector switch (S2) EXT. OFF. 400, 1000.	way, small frequency increments on either side of a main calibration may be obtained readily (par. 16b). Indicates percent modulation (sine wave) of output signal. Sets desired percent modulation on meter. Selects type of modulation as follows: 1000: Provides for internal sine-wave modulation at 1,000 cps. 400: Provides for internal sine-wave modulation at 400 cps. OFF: Deenergizes sine-wave modulation circuits. EXT: Allows for sine-wave modulation by an external source of 50 to 10,000 cps when source is connected to EXT. MOD. jack.
EXT. MOD. jack (J1)---	Provides means for connecting an external audio oscillator to modulation circuits of signal generator.
Pulse input jack (J2)---	Provides means for connecting an external pulse generator for pulse modulation.
EXT. PULSE switch (S3) OFF-ON.	Connects PULSE INPUT jack to plate circuit of carrier oscillator for pulse modulation.
OUTPUT meter (M1)---	Calibrates output levels indicated on MICROVOLTS dial.
MICROVOLTS carrier output dial and fiducial ring.	Sets carrier output to desired value by setting dial with reference to white line or PAD mark on fiducial ring. PAD mark is used only when 6-db pad is used between CARRIER OUTPUT jack and equipment under test. Fiducial ring must be adjusted so that pointer on OUTPUT meter rests opposite red line when modulation selector switch is in OFF position.
POWER ON-OFF switch (S1).	Controls application of a-c power to signal generator.
CARRIER OUTPUT jack (J3).	Provides means for connecting output of signal generator to equipment under test.

13. Use of Accessory Equipment

a. The impedance-matching pad (fixed attenuator Z1, fig. 2) may be connected to the CARRIER OUTPUT jack to properly terminate the output circuit of the generator. It introduces an attenuation of 6 db (reduces output voltage to one-half of the calibrated level). This loss is compensated for by setting the MICROVOLTS dial to the PAD mark on the fiducial ring.

b. Cord CG-55B/U and RF Cable Assembly CG-683/U (fig. 2) are provided for connection

between the signal generator and the equipment under test. Cord CG-55B/U is more convenient for equipments with coaxial input jacks and should be used with the fixed attenuator pad. RF Cable Assembly CG-683/U is more convenient for equipments without coaxial input jacks and is used without the fixed attenuator pad. This cable is not recommended for use above 100 mc. Paragraph 15 and figure 6 provide additional data on the use of the fixed attenuator pad and cables.

Section III. OPERATION UNDER USUAL CONDITIONS

14. Preliminary Starting Procedure

When the equipment is first received or is returned from a depot, the following preliminary starting procedure should be performed to determine whether it is in proper operating condition. Unless the generator has not been in use for an extended period of time, it will be unnecessary to follow the procedure outlined below before each operating period.

a. Connect the power plug to a 117-volt, 50/60-cycle, a-c source.

b. Terminate the generator output circuit by inserting the impedance-matching pad (fixed attenuator Z1) into the CARRIER OUTPUT jack.

c. Turn the POWER ON-OFF switch (fig. 5) to the ON position. Observe whether the carrier frequency dial is illuminated.

d. Turn the modulation selector switch to the OFF position.

e. Turn the EXT. PULSE switch to the OFF position.

f. Rotate the range knob until the letter A appears in the window above the knob. Rock the knob slightly from side to side to check that the range-change mechanism has locked into position.

g. Use the fiducial ring to set the OUTPUT meter pointer to the red line. Use the tuning knob to rotate the carrier frequency dial from one end to the other; note whether it is possible to set the meter pointer to the red line over the entire range. The frequency dial is disengaged automatically when the usable part of the band is past. This disengagement causes a jumpy action of the control and should not be mistaken for faulty operation.

h. Rotate the range knob clockwise to each of the other ranges (B, C, D, E, and F) successively,

while adjusting the fiducial ring at various settings of the carrier frequency dial as outlined in g above. If the OUTPUT meter pointer cannot be caused to reach the red line by adjusting the fiducial ring at any particular frequency or range, refer to paragraph 48c.

i. Turn the PERCENT MOD. knob to the extreme counterclockwise position and set the modulation selector switch to 400. Turn the PERCENT MOD. knob clockwise until the PERCENT MODULATION meter reads 30. The OUTPUT meter should deflect to the right of the red line as modulation is applied.

j. Turn the modulation selector switch to 1000. The PERCENT MODULATION meter should return to 30 without further adjustment of the PERCENT MOD. knob.

Note. If an abnormal result is obtained during the preliminary adjustments, refer to paragraph 48. Do not change the setting of the fiducial ring unless the OUTPUT meter pointer is not on the red line when the modulation selector switch is in the OFF position. Never adjust the fiducial ring when the modulation selector switch is in the 400 or 1000 position.

15. Connection to Equipment Under Test

a. *General.* The methods for interconnecting the signal generator to equipment under test must meet the basic requirement: The signal generator must be terminated in the proper impedance. If this is not done, the calibration of the output signal level will be incorrect and precise measurements will not be possible. The methods of interconnection discussed herein will permit proper termination of the signal generator. The methods are based on the assumption that the load impedance is essentially resistive. This is true for most applications for which this signal

generator will be used in the field. In the cases where the load impedance is not essentially resistive, it will be necessary for the operator to interpret these principles with respect to the nature of the load.

b. Methods of Connection. Six methods of interconnecting the signal generator to a resistive load are shown in figure 6. Three methods (1, 2, and 3) are based on the use of Cord CG-55B/U. The others (4, 5, and 6) are based on the use of RF Cable Assembly CG-683/U. Figure 6 shows that any input impedance can be matched by using either cable. However, it is recommended that methods 1, 2, and 3 be used for frequencies above 100 mc. With the use of either cable, all connections should be as short as possible, and the matching resistor placed as close as possible to the equipment under test.

c. Balanced and Unbalanced Inputs. All methods shown in figure 6 are for matching into an unbalanced load; that is, one of the input terminals, of the equipment under test, is at r-f ground potential. It is not possible to conveniently match this generator to a balanced input circuit. In those cases where it is necessary to work into a balanced input circuit, use the method (1 through 6) which correctly matches the impedance without regard to the unbalance. When tests or measurements are completed, reverse the two input leads at the input to the equipment under test and repeat the test. The second set of readings should closely approximate the first set because of autotransformer action of the balanced input coil.

d. Use of Impedance-Matching Pad (Fixed Attenuator Z1). The impedance-matching pad (fixed attenuator Z1) is a 6-db attenuator used to correctly terminate the signal generator when Cord CG-55B/U is used. When this pad is used, the MICROVOLTS dial is set to, or read at, the PAD reference mark. In this method of operation, the maximum available output signal is 50,000 μ v. This pad and unterminated Cord CG-55B/U generally is used when the equipment under test has a coaxial input type of connector. RF Cable Assembly CG-683/U generally is used when the equipment under test has binding post or screw-type terminals. When RF Cable Assembly CG-683/U is used, the pad is omitted. In either case, additional matching resistors may be required as shown in figure 6. RF Cable Assembly CG-683/U is not recommended for use above 100 mc.

e. Matching Resistors. All the matching resistors used in accordance with figure 6 must be of the noninductive composition type. All the matching resistors should be measured and adjusted to the exact values outlined in figure 6.

f. Connection of External Modulation Source. If sine-wave modulation at other than 400 or 1,000 cycles is required, or if pulse modulation is required, auxiliary equipment must be connected as outlined below.

- (1) Connect a sine-wave oscillator (such as Audio Oscillator TS-382A/U) to the EXT. MOD. jack for sine-wave modulation.
- (2) Connect a pulse generator (such as Signal Generator TS-155/UP) to the PULSE INPUT jack for pulse modulation.

Note. Leave the modulation selector and EXT. PULSE switches in the OFF positions until the output level has been set (par. 16).

16. Operation

a. Starting. Operate the POWER switch to the ON position. Permit a short period of time for the tubes to warm up. When making accurate measurements, allow at least 15 minutes for warm-up time before completing the final tuning.

b. Tuning. Tuning the generator involves selecting a range and tuning within that range as follows:

- (1) Rotate the range knob until the desired frequency band appears in the window of the carrier frequency dial. Rock the range knob slightly to check the detent position so that the desired frequency band coil contacts are engaged.
- (2) To set the signal generator to any frequency represented by a calibration mark on the carrier frequency dial (par. 12), turn the tuning knob until the desired calibration mark is opposite the frequency reference line in the window of the carrier frequency dial.
- (3) To tune to any frequency that falls between two calibrations, tune to the nearest lower calibration as instructed in (2) above, and interpolate as follows:
 - (a) Disengage the tuning knob from the tuning mechanism by pressing downward on the tuning knob. While holding the knob down, rotate it until the zero calibration is in line with the

METHOD	INPUT IMPEDANCE Z	CIRCUIT	MATCHING RESISTOR R_M	VOLTAGE APPLIED TO LOAD V_L
1	Z_1 IS LESS THAN 50Ω		$R_{M1} = 50 - Z_1$	$V_L = V_{INDICATED} \times \frac{Z_1}{50}$
2	Z_2 IS BETWEEN 50Ω AND 500Ω		$R_{M2} = \frac{50(Z_2)}{(Z_2) - 50}$	$V_L = V_{INDICATED}$
3	Z_3 IS 500Ω OR GREATER		$R_{M3} = 50\Omega$	$V_L = V_{INDICATED}$
4	Z_4 IS LESS THAN 50Ω		$R_{M4} = 50 - Z_4$	$V_L = V_{INDICATED} \times \frac{Z_4}{50}$
5	Z_5 IS BETWEEN 50Ω AND 500Ω		$R_{M5} = \frac{50(Z_5)}{(Z_5) - 50}$	$V_{INDICATED}$
6	Z_6 IS 500Ω OR GREATER		NO MATCHING RESISTOR REQUIRED	$V_{INDICATED}$

NOTES:

1. ALL MATCHING RESISTORS MUST BE OF THE NON-INDUCTIVE COMPOSITION TYPE.
2. IMPEDANCE MATCHING PAD IS NOT USED IN METHODS 4 TO 6.

TM 5030A-22

Figure 6. Connections to equipment under test.

white tuning knob reference mark above the knob (fig. 5). Release the knob carefully to avoid disturbing the setting of the carrier frequency dial.

- (b) Turn the tuning knob slowly until the carrier frequency dial has moved through a single scale division; that is, until the next higher calibration mark is opposite the frequency reference line. Note the number of tuning knob

divisions required for the one-division movement of the carrier frequency dial. Note also the frequency spacings between calibrations on the carrier frequency dial (par. 12).

- (c) Determine the proper setting of the tuning dial from the following formula, and turn the tuning knob back to this setting.

$$\text{Tuning knob setting} = \frac{\text{Desired frequency} - \text{frequency of nearest lower calibration}}{\text{Frequency spacing on carrier frequency dial}} \times \text{Tuning dial divisions per carrier frequency dial division}$$

Example: Desired frequency is 13.15 mc.
 Nearest lower calibration is 13.0 mc.
 Desired frequency minus frequency of nearest lower calibration is 0.15 mc.
 Frequency spacing on carrier frequency dial is 0.2 mc (par. 12).
 Tuning knob divisions per carrier frequency dial division are 20 (assumed).

$$\text{Tuning knob setting is } \frac{0.15}{0.20} \times 20 = 15.$$

Note. The tuning knob rotation required to move the carrier frequency dial from one calibration to the next is different on each band and varies from one end of each band to the other. The procedure above must be followed for each interpolation.

c. Setting Carrier Level. With the modulation selector switch in the OFF position, turn the fiducial ring until the pointer of the OUTPUT meter rests on the red line. Set the carrier output by setting the desired value on the MICROVOLTS dial to the white line on the fiducial ring. When the 6-db matching pad is used between the signal generator and the equipment under test, set the MICROVOLTS dial to the PAD mark on the fiducial ring.

d. Modulating With Sine Wave. To use sine-wave modulation, perform the following steps:

- (1) For sine-wave modulation at 400 or 1000 cycles, set the modulation selector switch to either 400 or 1000 cycles, as required.
- (2) If external sine-wave modulation is used (par. 15f), set the modulation selector switch to the EXT. position.

- (3) Connect on external audio oscillator, adjusted for 7- to 10-volt output, to the EXT. MOD. jack on the front panel.
- (4) Adjust the PERCENT MOD. knob until the PERCENT MODULATION meter indicates the desired percentage of modulation.

Note. During sine-wave modulation, the position of the pointer on the OUTPUT meter will change. This is a normal response and should be ignored. Never change the fiducial ring setting unless the modulation selector switch is in the OFF position.

e. Pulse Modulation. If pulse modulation is used (par. 15f), turn the modulation selector switch to the OFF position. Turn the EXT. PULSE switch clockwise to the ON position. This disconnects the internal modulator and permits direct pulse modulation of the carrier from an external pulse generator connected at the PULSE INPUT jack. The external pulse must be at least 150 volts peak. The PERCENT MODULATION meter will not read during pulse modulation operation.

Note. For detailed information on the calibration and operation of auxiliary equipment, refer to the technical manuals for the particular instruments.

17. Operation Under Unusual Conditions

If Signal Generator TS-497B/URR is required in performing tests under severe climatic conditions that prevail in tropical, arctic, or desert regions, or where excessive moisture, dust, or sand is present, the same precautions that apply to the equipment under test will apply to the signal generator. The manual covering the equipment under test tells how the equipment should be housed and gives methods of dustproofing, moistureproofing, ventilating, etc.

CHAPTER 3

ORGANIZATIONAL MAINTENANCE INSTRUCTIONS

Section I. ORGANIZATIONAL TOOLS AND EQUIPMENT

18. Tools and Materials

Organizational tools and materials required for the maintenance of Signal Generator TS-497B/URR are contained in Tool Equipment TE-41, and are listed in Department of the Army Supply Catalog SIG 6-TE-41. In addition to these tools, a 1-inch open-end, flat wrench is re-

quired for removing the coil disk retaining nut in the oscillator coil disk assembly.

19. Special Tools Supplied

Four Allen wrenches, sizes No. 4, 6, 8, and 10, are supplied with the signal generator. These wrenches are located in the spare parts compartment (fig. 3).

Section II. PREVENTIVE MAINTENANCE SERVICE

20. Definition of Preventive Maintenance

Preventive maintenance is work performed on equipment (usually when the equipment is not in use) to keep it in good working order so that breakdowns and needless interruptions in service will be kept at a minimum. Preventive maintenance differs from troubleshooting and repair since its object is to prevent certain troubles from occurring. See AR 750-5.

21. General Preventive Maintenance Techniques

- a. Use No. 0000 sandpaper to remove corrosion.
- b. Use a clean, dry, lint-free cloth or dry brush for cleaning.
 - (1) If necessary, except for electrical contacts, moisten the cloth or brush with solvent, dry-cleaning (SD); then wipe the parts dry with a cloth.
 - (2) Clean electrical contacts with a cloth moistened with carbon tetrachloride; then wipe them dry with a dry cloth.

Caution: Repeated contact of carbon tetrachloride with the skin or prolonged breathing of the fumes is dangerous. Make sure adequate ventilation is provided.

c. If available, dry compressed air may be used at a line pressure not exceeding 60 psi (pounds per square inch) to remove dust from inaccessible places.

Caution: Be sure that both inner and outer shields of the carrier oscillator drum and the filter covers are in place before applying air pressure.

d. For further information on preventive maintenance techniques, refer to TB SIG 178.

22. Use of Preventive Maintenance Forms (figs. 7 and 8)

a. The decision as to which items on DA AGO Forms 11-238 and 11-239 are applicable to this equipment is a tactical decision to be made in the case of the first echelon maintenance by the communication officer/chief or his designated representative, and in the case of the second and third echelon maintenance, by the individual making the inspection. Instructions for the use of each form appear on the reverse side of the form.

b. Circled items in figures 7 and 8 are partially or totally applicable to Signal Generator TS-497B/URR. References in the ITEM block refer to paragraphs in the text which contain additional maintenance information.

OPERATOR FIRST ECHELON MAINTENANCE CHECK LIST FOR SIGNAL CORPS EQUIPMENT
RADIO COMMUNICATION, DIRECTION FINDING, CARRIER, RADAR

INSTRUCTIONS: See other side

EQUIPMENT NOMENCLATURE

SIGNAL GENERATOR TS-497B/URR

EQUIPMENT SERIAL NO.

LEGEND FOR MARKING CONDITIONS: ✓ Satisfactory; X Adjustment, repair or replacement required; (X) Defect corrected.
 NOTE: Strike out items not applicable.

DAILY

NO.	ITEM	CONDITION						
		S	M	T	W	T	F	S
1	COMPLETENESS AND GENERAL CONDITION OF EQUIPMENT (receiver, transmitter, carrying cases, wire and cable, microphones, tubes, spare parts, technical manuals and accessories). PAR. 23 a (1)							
2	LOCATION AND INSTALLATION SUITABLE FOR NORMAL OPERATION.							
3	CLEAN DIRT AND MOISTURE FROM ANTENNA, MICROPHONE, HEADSETS, CHESTSETS, KEYS, JACKS, PLUGS, TELEPHONES, CARRYING BAGS, COMPONENT PANELS. PAR. 23 a (2)							
4	INSPECT SEATING OF READILY ACCESSIBLE "PLUCK-OUT" ITEMS: TUBES, LAMPS, CRYSTALS, FUSES, CONNECTORS, VIBRATORS, PLUG-IN COILS AND RESISTORS.							
5	INSPECT CONTROLS FOR BINDING, SCRAPING, EXCESSIVE LOOSENESS, WORN OR CHIPPED GEARS, MISALIGNMENT, POSITIVE ACTION. PAR. 23 a (5)							
6	CHECK FOR NORMAL OPERATION. PAR. 23 a (3)							

WEEKLY

NO.	ITEM	COND- TION	NO.	ITEM	COND- TION
7	CLEAN AND TIGHTEN EXTERIOR OF COMPONENTS AND CASES, RACK MOUNTS, SHOCK MOUNTS, ANTENNA MOUNTS, COAXIAL TRANSMISSION LINES, WAVE GUIDES, AND CABLE CONNECTIONS. PAR. 23 a (6), (10), AND (11)		13	INSPECT STORAGE BATTERIES FOR DIRT, LOOSE TERMINALS, ELECTROLYTE LEVEL AND SPECIFIC GRAVITY, AND DAMAGED CASES.	
8	INSPECT CASES, MOUNTINGS, ANTENNAS, TOWERS, AND EXPOSED METAL SURFACES, FOR RUST, CORROSION, AND MOISTURE. PAR. 23 a (7)		14	CLEAN AIR FILTERS, BRASS NAME PLATES, DIAL AND METER WINDOWS, JEWEL ASSEMBLIES. PAR. 23 a (9)	
9	INSPECT CORD, CABLE, WIRE, AND SHOCK MOUNTS FOR CUTS, BREAKS, FRAYING, DETERIORATION, KINKS, AND STRAIN. PAR. 23 a (8)		15	INSPECT METERS FOR DAMAGED GLASS AND CASES. PAR. 23 a (9)	
10	INSPECT ANTENNA FOR ECCENTRICITIES, CORROSION, LOOSE FIT, DAMAGED INSULATORS AND REFLECTORS.		16	INSPECT SHELTERS AND COVERS FOR ADEQUACY OF WEATHER-PROOFING.	
11	INSPECT CANVAS ITEMS, LEATHER, AND CABLING FOR MILDEW, TEARS, AND FRAYING. PAR. 23 a (4)		17	CHECK ANTENNA GUY WIRES FOR LOOSENESS AND PROPER TENSION.	
12	INSPECT FOR LOOSENESS OF ACCESSIBLE ITEMS: SWITCHES, KNOBS, JACKS, CONNECTORS, ELECTRICAL TRANSFORMERS, POWER-STATS, RELAYS, SELSYNS, MOTORS, BLOWERS, CAPACITORS, GENERATORS, AND PILOT LIGHT ASSEMBLIES.		18	CHECK TERMINAL BOX COVERS FOR CRACKS, LEAKS, DAMAGED GASKETS, DIRT AND GREASE.	

19 IF DEFICIENCIES NOTED ARE NOT CORRECTED DURING INSPECTION, INDICATE ACTION TAKEN FOR CORRECTION.

DA AGO FORM 11-238
1 MAY 51

REPLACES DA AGO FORM 419, 1 DEC 50, WHICH IS OBSOLETE.

TM 5030A-20

Figure 7. DA AGO Form 11-238.

SECOND AND THIRD ECHELON MAINTENANCE CHECK LIST FOR SIGNAL CORPS EQUIPMENT			
RADIO COMMUNICATION, DIRECTION FINDING, CARRIER, RADAR			
INSTRUCTIONS: See other side			
EQUIPMENT NOMENCLATURE		EQUIPMENT SERIAL NO.	
SIGNAL GENERATOR TS-497B/URR			
LEGEND FOR MARKING CONDITIONS: ✓ Satisfactory; X Adjustment, repair or replacement required; ⊕ Defect corrected; NOTE: Strike out items not applicable.			
NO	ITEM	NO.	ITEM
1	COMPLETENESS AND GENERAL CONDITION OF EQUIPMENT (receiver, transmitter, carrying cases, wire and cable, microphone, tubes, spare parts, technical manuals and accessories). PAR. 23 b (1) AND (3)	19	ELECTRON TUBES - INSPECT FOR LOOSE ENVELOPES, CAP CONNECTIONS, CRACKED SOCKETS; INSUFFICIENT SOCKET SPRING TENSION; CLEAN DUST AND DIRT CAREFULLY; CHECK EMISSION OF RECEIVER TYPE TUBES. PAR. 23 b (7) AND (16)
2	LOCATION AND INSTALLATION SUITABLE FOR NORMAL OPERATION.	20	INSPECT FILM CUT-OUTS FOR LOOSE PARTS, DIRT, MISALIGNMENT AND CORROSION.
3	CLEAN DIRT AND MOISTURE FROM ANTENNA, MICROPHONE, HEADSETS, CHESTSETS, KEYS, JACKS, PLUGS, TELEPHONES, CARRYING BAGS, COMPONENT PANELS. PAR. 23 b (12)	21	INSPECT FIXED CAPACITORS FOR LEAKS, BULGES, AND DISCOLORATION. PAR. 23 b (10)
4	INSPECT SEATING OF READILY ACCESSIBLE "PLUCK-OUT" ITEMS: TUBES, LAMPS, CRYSTALS, FUSES, CONNECTORS, VIBRATORS, PLUG-IN COILS AND RESISTORS. PAR. 23 b (8) AND (14)	22	INSPECT RELAY AND CIRCUIT BREAKER ASSEMBLIES FOR LOOSE MOUNTINGS; BURNED, PITTED, CORRODED CONTACTS; MISALIGNMENT OF CONTACTS AND SPRINGS; INSUFFICIENT SPRING TENSION; BINDING OF PLUNGERS AND HINGE PARTS.
5	INSPECT CONTROLS FOR BINDING, SCRAPING, EXCESSIVE LOOSENESS, WORN OR CHIPPED GEARS, MISALIGNMENT, POSITIVE ACTION.	23	INSPECT VARIABLE CAPACITORS FOR DIRT, MOISTURE, MISALIGNMENT OF PLATES, AND LOOSE MOUNTINGS.
6	CHECK FOR NORMAL OPERATION. PAR. 23 b (5)	24	INSPECT RESISTORS, BUSHINGS, AND INSULATORS, FOR CRACKS, CHIPPING, BLISTERING, DISCOLORATION AND MOISTURE. PAR. 23 b (9)
7	CLEAN AND TIGHTEN EXTERIOR OF COMPONENTS AND CASES, RACK MOUNTS, SHOCK MOUNTS, ANTENNA MOUNTS, COAXIAL TRANSMISSION LINES, WAVE GUIDES, AND CABLE CONNECTIONS.	25	INSPECT TERMINALS OF LARGE FIXED CAPACITORS AND RESISTORS FOR CORROSION, DIRT AND LOOSE CONTACTS. PAR. 23 b (11) AND (14)
8	INSPECT CASES, MOUNTINGS, ANTENNAS, TOWERS, AND EXPOSED METAL SURFACES, FOR RUST, CORROSION, AND MOISTURE. PAR. 23 b (2) AND (4)	26	CLEAN AND TIGHTEN SWITCHES, TERMINAL BLOCKS, BLOWERS, RELAY CASES, AND INTERIORS OF CHASSIS AND CABINETS NOT READILY ACCESSIBLE. PAR. 23 b (14)
9	INSPECT CORD, CABLE, WIRE, AND SHOCK MOUNTS FOR CUTS, BREAKS, FRAYING, DETERIORATION, KINKS, AND STRAIN.	27	INSPECT TERMINAL BLOCKS FOR LOOSE CONNECTIONS, CRACKS AND BREAKS. PAR. 23 b (14)
10	INSPECT ANTENNA FOR ECCENTRICITIES, CORROSION, LOOSE FIT, DAMAGED INSULATORS AND REFLECTORS.	28	CHECK SETTINGS OF ADJUSTABLE RELAYS.
11	INSPECT CANVAS ITEMS, LEATHER, AND CABLING FOR MILDEW, TEARS, AND FRAYING.	29	LUBRICATE EQUIPMENT IN ACCORDANCE WITH APPLICABLE DEPARTMENT OF THE ARMY LUBRICATION ORDER.
12	INSPECT FOR LOOSENESS OF ACCESSIBLE ITEMS: SWITCHES, KNOBS, JACKS, CONNECTORS, ELECTRICAL TRANSFORMERS, POWERSTATS, RELAYS, SELSYNS, MOTORS, BLOWERS, CAPACITORS, GENERATORS, AND PILOT LIGHT ASSEMBLIES. PAR. 23 b (7) AND (15)	30	INSPECT GENERATORS, AMPLIFIERS, DYNAMOTORS, FOR BRUSH WEAR, SPRING TENSION, ARCING, AND FITTING OF COMMUTATOR.
13	INSPECT STORAGE BATTERIES FOR DIRT, LOOSE TERMINALS, ELECTROLYTE LEVEL AND SPECIFIC GRAVITY, AND DAMAGED CASES.	31	CLEAN AND TIGHTEN CONNECTIONS AND MOUNTINGS FOR TRANSFORMERS, CHOKES, POTENTIOMETERS, AND RHEOSTATS. PAR. 23 b (6) AND (14)
14	CLEAN AIR FILTERS, BRASS NAME PLATES, DIAL AND METER WINDOWS, JEWEL ASSEMBLIES.	32	INSPECT TRANSFORMERS, CHOKES, POTENTIOMETERS, AND RHEOSTATS FOR OVERHEATING AND OIL-LEAKAGE.
15	INSPECT METERS FOR DAMAGED GLASS AND CASES.	33	BEFORE SHIPPING OR STORING - REMOVE BATTERIES.
16	INSPECT SHELTERS AND COVERS FOR ADEQUACY OF WEATHERPROOFING.	34	INSPECT CATHODE RAY TUBES FOR BURNED SCREEN SPOTS.
17	CHECK ANTENNA GUY WIRES FOR LOOSENESS AND PROPER TENSION.	35	INSPECT BATTERIES FOR SHORTS AND DEAD CELLS.
18	CHECK TERMINAL BOX COVERS FOR CRACKS, LEAKS, DAMAGED GASKETS, DIRT AND GREASE.	36	INSPECT FOR LEAKING WATERPROOF GASKETS, WORN OR LOOSE PARTS.
		37	MOISTURE AND FUNGIPROOF. PAR. 23 b (13)
38	IF DEFICIENCIES NOTED ARE NOT CORRECTED DURING INSPECTION, INDICATE ACTION TAKEN FOR CORRECTION.		

DA AGO FORM 11-239
1 MAY 52

REPLACES DA AGO FORM 429, 1 DEC 50, WHICH IS OBSOLETE.

16-6880-1

TM 5030A-21

Figure 8. DA AGO Form 11-239.

23. Performing Preventive Maintenance

Perform the following preventive maintenance operations at the intervals indicated, unless these intervals are reduced by the local commander.

Caution: Tighten screws, bolts, and nuts carefully. Fittings tightened beyond the pressure for which they are designed will be broken or damaged.

a. External Preventive Maintenance.

- (1) Check for completeness and satisfactory condition of the signal generator and the spare parts.
- (2) Remove dirt and moisture from the case and panel.
- (3) Check for normal operation.
- (4) Remove the dirt and moisture from the a-c power cord and all other cords associated with the equipment.
- (5) Inspect all the panel controls for binding, scraping, looseness, and positive action.
- (6) Tighten the mounting screws that hold the panels to the case.
- (7) Inspect the metal surfaces for scratches, indentures, and rust.
- (8) Inspect the cables for frayed insulation, breaks, and cuts.
- (9) Inspect the meter glasses for cracks, dirt, and moisture.
- (10) Inspect the hasp-type latches for positive action and rust.
- (11) Inspect the front and back covers for tightness of fit.

b. Internal Preventive Maintenance.

- (1) Check the equipment for its general condition, the spare parts, and completeness.

- (2) Remove the dirt and moisture from the interior of the two covers, spare parts compartment, cable compartment, and case.
- (3) Inspect all spare parts in the spare parts compartment for completeness and usability.
- (4) Inspect the metal surfaces for rust and scratches.
- (5) Check the set for normal operation.
- (6) Inspect the meter connections for tightness.
- (7) Inspect the vacuum tubes for loose envelopes; the sockets for cracks, dirt, and moisture.
- (8) Inspect fuse F1 for dirt and moisture and positive fit.
- (9) Inspect the resistors for heating, discoloration, and cracks.
- (10) Inspect the fixed capacitors for bulges, dirt, and moisture.
- (11) Inspect the terminals of resistors and capacitors for corrosion and positive contacts.
- (12) Remove the dirt and moisture from all the components.
- (13) Inspect the moistureproofing and fungiproofing for cracks.
- (14) Inspect all electrical connections for tightness.
- (15) Inspect the door on the spare parts compartment for dirt and moisture, and the Dzus fasteners for positive action.
- (16) Inspect pluck-out parts, such as vacuum tubes, vacuum-tube shields, and crystals, for seating.

Section III. LUBRICATION AND WEATHERPROOFING

24. Lubrication and Weatherproofing

a. *General.* Signal Generator TS-497B/URR requires no lubrication. Signal Corps equipment, when operated under severe climatic conditions such as prevail in tropical, arctic, and desert regions, requires special treatment and maintenance. Fungus growth, insects, dust, corrosion, salt spray, excessive moisture, and extreme temperatures are harmful to most materials.

b. *Tropical Maintenance.* A special moistureproofing and fungiproofing treatment has been devised which, if properly applied, provides a

reasonable degree of protection. This treatment is explained in TB SIG 13 and TB SIG 72.

c. *Winter Maintenance.* Special precautions necessary to prevent poor performance or total operational failure of equipment in extremely low temperatures are explained in TB SIG 66 and TB SIG 219.

d. *Desert Maintenance.* Special precautions necessary to prevent equipment failure in areas subject to extremely high temperatures, low humidity, and excessive sand and dust are explained in TB SIG 75.

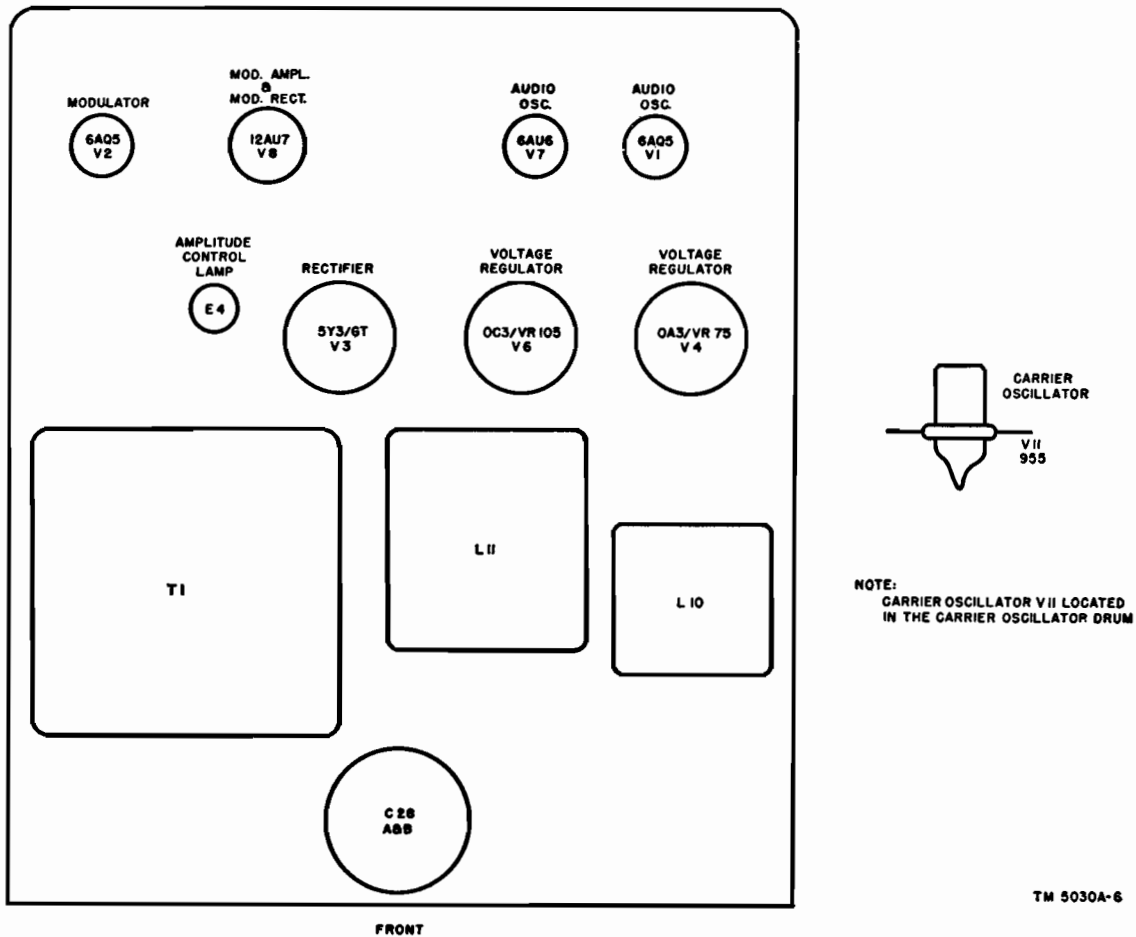

Figure 9. Tube location diagram.

25. Rustproofing and Painting

a. When the finish on the case has been badly scarred or damaged, touch up the exposed surfaces to prevent rust and corrosion. Use No. 000 or No. 0000 sandpaper to clean the surface down to the bare metal; obtain a bright smooth finish.

Caution: Do not use steel wool. Minute particles frequently enter the case and cause harmful internal shorting or grounding of circuits.

b. When a touchup job is necessary, apply paint with a small brush. Remove rust from the case by cleaning corroded metal with solvent, dry-cleaning (SD). In severe cases it may be necessary to use the solvent (SD) to soften the rust and to use sandpaper to complete the preparation for painting. Paint used will be authorized and consistent with existing regulations (TM 9-2851).

Section IV. TROUBLESHOOTING AT ORGANIZATIONAL MAINTENANCE LEVEL

26. General

a. The troubleshooting and repair work that can be performed at the organizational maintenance level (operators and repairmen) is necessarily limited in scope by the tools, test equipment, and replaceable parts issued, and by the existing tactical situation. Accordingly, troubleshooting

is based on the performance of the equipment and the use of the senses in determining such troubles as burned-out tubes, etc.

b. Paragraphs 27 through 29 help in determining which portion of the equipment, such as the audio oscillator, carrier oscillator, or modulator, is at fault, and in localizing the fault within that portion.

27. Visual Inspection

a. Failure of the signal generator to operate properly will usually be caused by one or more of the following faults:

- (1) Worn, broken, or disconnected cords and plugs.
- (2) Burned-out fuses.
- (3) Wires broken because of excessive vibration.
- (4) Defective tubes.
- (5) Defective crystal rectifiers.

b. When failure is encountered and the cause is not immediately apparent, check as many of the foregoing items as is practicable before starting a detailed examination of the component parts of the equipment. If possible, obtain information from the operator of the equipment regarding performance at the time trouble occurred.

28. Troubleshooting by Using Equipment Performance Checklist

a. *General.* The equipment performance checklist (par. 29) will help the operator to locate trouble in the equipment. The list gives items

to be checked, the conditions under which the item is checked, the normal indications of correct operation, and the corrective measures the operator can take. *In using this list, perform the checks in numerical sequence.*

b. *Action or Condition.* The information given in the *Action or condition* column consists of various switch and control settings under which the item is to be checked.

c. *Normal Indications.* The normal indications listed include the visible and audible signs that the operator should perceive when he checks the items. If the indications are not normal, the operator should apply the recommended corrective measures or turn the equipment in for troubleshooting and maintenance.

d. *Corrective Measures.* The corrective measures listed are those the operator can make without turning in the equipment for repairs. A reference in the table to chapter 5 indicates that the trouble cannot be cleared during operation and that troubleshooting by an experienced repairman is necessary. If the set is completely inoperative or if the recommended corrective measures do not yield results, troubleshooting is necessary.

29. Equipment Performance Checklist

	Item No.	Item	Action or condition	Normal indications	Corrective measures
P R E P A R A T O R Y	1	Line cord.....	Connect to source of a-c power.	-----	Check fuse F1 on front panel. Check linecord.
	2	Modulation selector switch.	Operate to OFF position.....	-----	
	3	EXT. PULSE switch....	Operate to OFF position.....	-----	
	4	Range knob.....	Operate to band A.....	-----	
	5	POWER switch.....	Operate to ON position....	Dial light lights.....	
E Q U I P M E N T P E R F O R M A N C E	6	Fiducial ring.....	Set for OUTPUT meter reading on red line after determining that the fiducial ring actually controls meter reading. <i>Note.</i> If OUTPUT meter reading is controllable and the dial light is inoperative, replace the dial light.	Fiducial ring controls meter reading. If fiducial ring controls OUTPUT meter reading but will not reach red line, see chapter 5.	See par. 47 (check for failure of 180-volt supply).
	7	Band switch.....	Set successively to bands A, B, C, D, E, and F.	Fiducial ring controls OUTPUT meter reading and reaches red line on each band.	See par. 48.
	8	Modulation selector switch.	Set to 400.....	-----	

EQUIPMENT PERFORMANCE—Continued

Item No.	Item	Action or condition	Normal indications	Corrective measures
9	PERCENT MOD. control.	Turn clockwise-----	PERCENT MODULATION meter reads. OUTPUT meter reading rises above red line at 30% reading of PERCENT MODULATION meter.	See par. 48.
10	Modulation selector switch.	Set to 1000.-----	Same as above-----	See par. 48.
11	Modulation selector switch.	Set to either 400 or 1000.---	PERCENT MODULATION meter will indicate 30.	Check tubes VI and V7.
12	EXT. PULSE switch----	Set to ON-----	OUTPUT meter swings to left end of scale. PERCENT MODULATION meter reading will increase. No output from generator.	See par. 48.
13	Modulation selector switch.	Set to OFF-----	PERCENT MODULATION reading falls to zero. OUTPUT meter swings to left end of scale.	See par. 48.
14	Modulation selector switch.	Set to 400-----		
	Band switch-----	Set to A-----		
	Frequency meter-----	Connect to output of signal generator and tune to carrier oscillator frequency.		
	MICROVOLTS dial----	Vary the setting-----	Varying signal intensity at output of frequency meter.	See par. 48.

CHAPTER 4

THEORY

30. Block Diagram

(fig. 10)

Signal Generator TS-497B/URR consists essentially of a carrier frequency oscillator to provide r-f test signals that cover a range from 2 to 400 mc. The various stages of the signal generator are shown in figure 10. A complete schematic is shown in figure 24.

a. Audio Oscillator. The audio oscillator generates a sine-wave voltage of either 400 or 1,000 cycles for amplitude modulation of the carrier oscillator. Either of these signals may be supplied to the modulator through a selector switch.

b. Modulator. The modulator circuit amplifies the output of the audio oscillator, or the signal from an external audio oscillator, and uses the amplified signal to modulate the plate voltage of the carrier oscillator. The metering portion of the circuit indicates the output of the modulator in terms of percent modulation.

c. Carrier Oscillator. The carrier oscillator generates an r-f signal that is between 2 and 400 mc. Six bands (par. 4) are used to cover the frequency range. The output of the carrier oscillator is metered and coupled to a CARRIER OUTPUT jack through a variable attenuator. The attenuator is of the mutual inductance type and is commonly referred to as a *piston attenuator*.

d. Output Metering System.

- (1) This circuit includes a crystal diode rectifier, a temperature-compensating crystal, and an OUTPUT meter. A d-c (direct-current) bias, applied to the measuring crystal through the temperature-compensating crystal, determines the portion of the characteristic curve in which the crystal operates. The r-f energy fed to the measuring crystal is rectified and indicated by the OUTPUT meter. The compensating crystal varies the d-c bias to compensate for temperature changes.

- (2) The meter reading indicates that the calibration of the MICROVOLTS dial (output attenuator) is a true indication of the carrier output voltage. The correlations between the OUTPUT meter reading and the reading of the MICROVOLTS dial, depend upon the calibration procedure outlined in paragraph 61.

31. Audio Oscillator

(fig. 11)

a. A resistance-capacitance type oscillator is used to generate a 400- or 1,000-cycle sine-wave modulating voltage for the carrier oscillator. The audio oscillator consists essentially of a two-stage resistance-coupled amplifier (V7 and V1) with both regenerative and degenerative feedback from the second stage to the first stage.

b. When modulation selector switch S2 is in the 400-cycle position, regenerative voltage is coupled from the plate of V1 to the grid of V7 through capacitor C34 and the frequency-determining elements of the circuit, capacitors C20 and C21 and resistors R23, and R24. The values of the frequency-determining elements are chosen so that the regenerative voltage will be in phase with the grid voltage at 400 cycles. When switch S2 is placed in the 1,000-cycle position, resistors R23 and R24 are paralleled by resistors R25 and R26, respectively, and the regeneration occurs at 1,000 cycles.

c. Degenerative voltage is coupled from the plate of V1 to the cathode of V7 through capacitor C34 and resistor R31. E4 is a 3-watt lamp that functions as a variable resistance to control the amplitude of the oscillator output. If the amplitude at the plate of V1 tends to rise, the current through E4 will increase, thus raising the voltage at the cathode of V7 and reducing the gain of the tube. The increased degeneration will offset the tendency of a rise in the oscillator output. Conversely, a tendency for the oscillator output to decrease will cause decreased degeneration and a

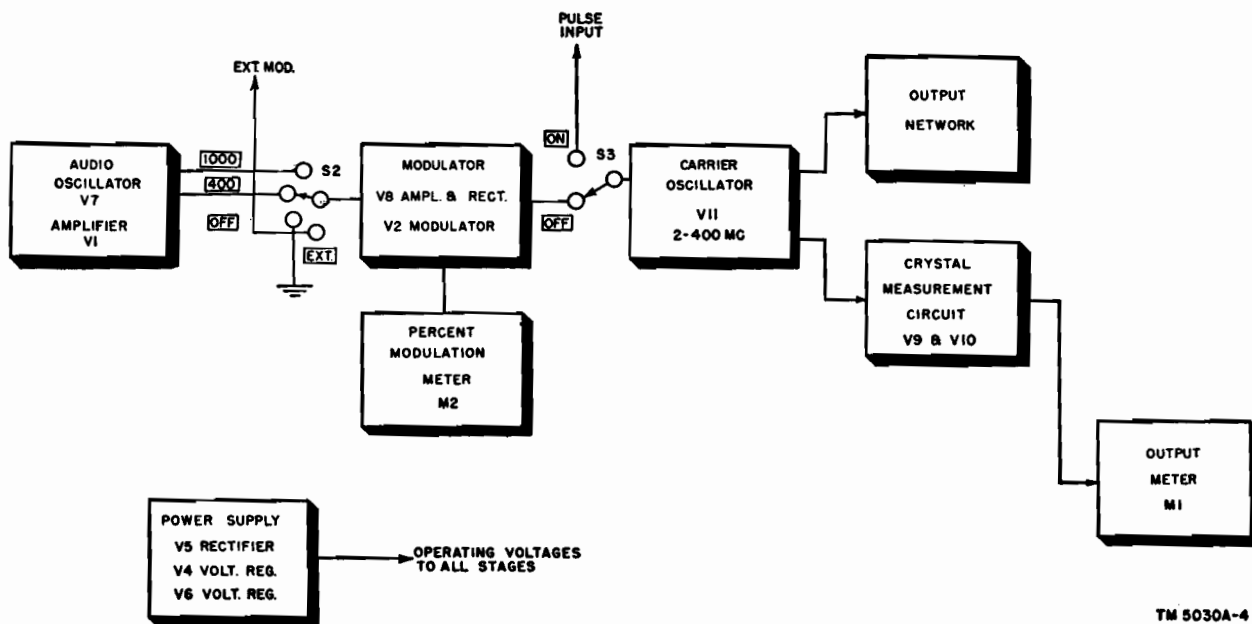

Figure 10. Block diagram.

TM 5030A-4

corresponding increase in amplification through V7.

d. Plate voltage and screen voltage for V7 are obtained from the 180-volt output of the power supply. The plate voltage is supplied through load resistor R45, and the screen voltage through dropping resistor R27. Capacitor C22 bypasses the screen to the cathode. Plate voltage for V1 is obtained from the 300-volt output of the power supply through parallel load resistors R8 and R28. The 180-volt output of the power supply is used as screen voltage.

e. Assuming that there is some output from V7 (regardless of the amplitude or frequency), a signal will be developed across grid resistor R29 and will be amplified by V1. Regenerative feedback, from the plate of V1 to the grid of V7, will be developed across the resistance-capacitance network between the grid of V7 and ground. Because of the reactive nature of capacitors C20 and C21, the phase of the regenerative voltage, relative to the voltage at the grid of V7, will vary with frequency. In-phase regeneration will occur at either 400 or 1,000 cycles, depending on the position of Switch S2.

f. The output from V1 is developed across parallel resistors R8 and R28. Capacitors C34 (fig. 24) and a section on modulation selector switch S2 couple the output to the modulator section.

When switch S2 is in the OFF or EXT. position, the audio oscillator is inoperative. Resistor R30 is the cathode bias resistor for tube V1.

32. Modulator

(fig. 12)

The modulator circuit amplifies the sine-wave voltage generated by the internal audio oscillator, or an external oscillator (par. 33), and impresses this signal upon the carrier oscillator. The circuit consists of a modulation amplifier (section B of V8), a modulator (V2), and a modulation rectifier (section A of V8).

a. The modulator circuit obtains its input signal voltage from the internal audio oscillator through modulation selector switch S2 when it is in the 400 or 1,000 position, depending on whether 400 or 1,000 cycles is desired. The arm of selector switch S2 applies the voltage to modulation volume control R33 (PERCENT MOD.). R33 permits adjusting the percentage of modulation from 0 to 30 percent. The voltage at the arm of R33 is applied to the grid (pin 7) of the amplifier section of V8 through d-c isolation capacitor C33. The grid is returned through grid resistor R46 to the junction of cathode resistors R34 and R35. Fixed bias for the amplifier is developed across resistor R34 by the bleeder current that flows from ground through resistors R35, R34, and R36, and modulation choke L10 to B plus.

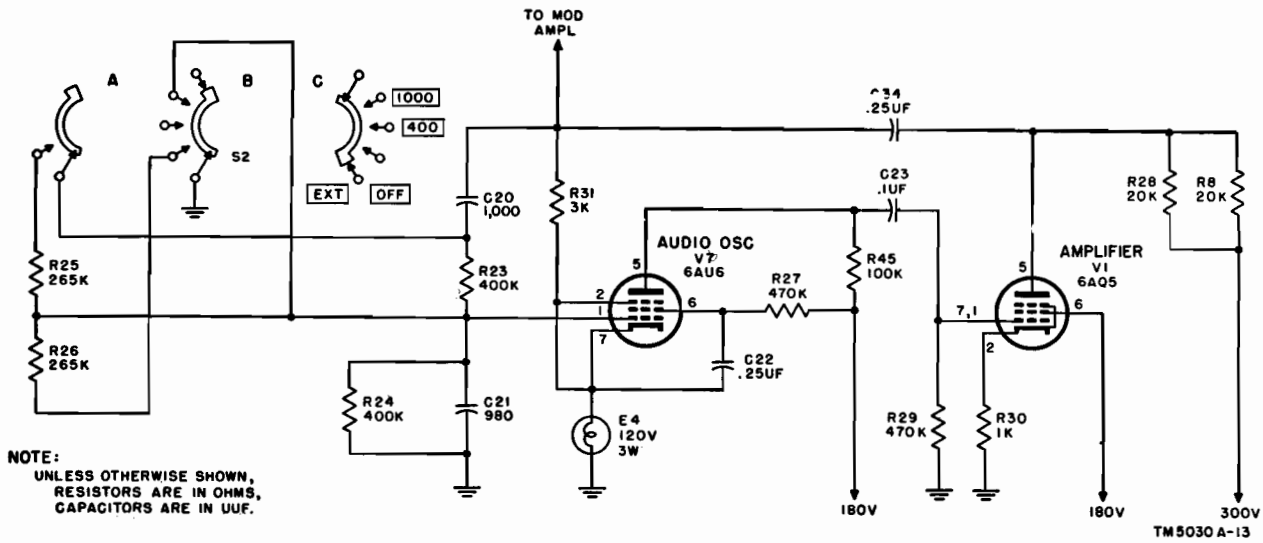

Figure 11. Audio oscillator schematic.

b. Plate voltage for the V8B is obtained from the 180-volt output of the power supply through load resistor R32. The output of V8B is coupled to the grid of modulator tube V2 through blocking capacitor C26. The grid of tube V2 is returned to ground through grid resistor R37. Bias for tube V2 is obtained by the voltage drop across cathode resistor R38. Screen voltage is obtained from the 180-volt supply. Plate voltage for V2 and carrier oscillator tube V11 (par. 24) is obtained from the 180-volt supply through modulation choke L10.

Since the voltage across the choke varies in accordance with the sine-wave voltage at the grid of V2, the plate voltage of the carrier oscillator will vary at the same audio frequency.

c. A portion of the output of V2 (fig. 12) is fed back through R36 to the cathode of V8B. This negative feedback reduces the amount of distortion in the modulator.

d. Another portion of the output of V2 is fed through blocking capacitor C27 and voltage dividers R39 and R40 to the plate of V8A. The plate

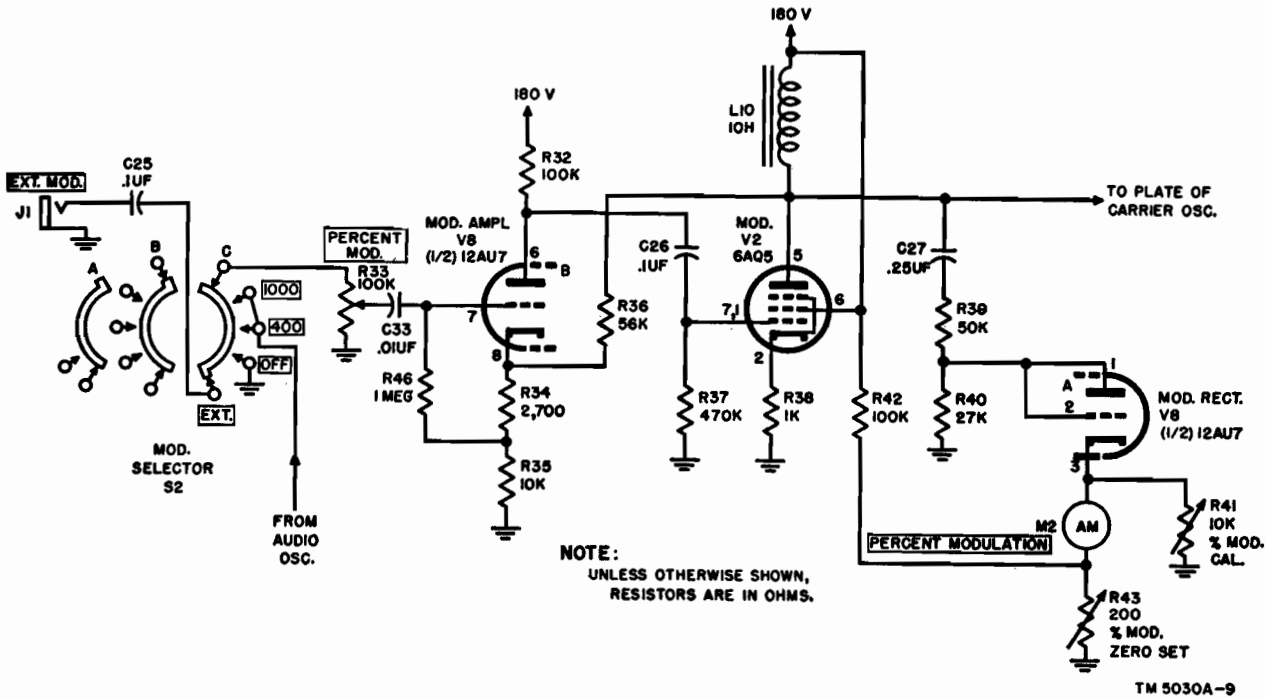

Figure 12. Sine-wave modulator schematic.

and grid of V8A are connected so that the tube functions as a diode rectifier. PERCENT MODULATION meter M2 is connected in the cathode of V8A (pin 3) to indicate the amount of rectified audio frequency. When there is no audio variation at the plate of V8A (pin 1), the tube should be nonconductive and the meter should read zero. However, the contact potential of the tube would cause the tube to conduct (and the meter to read) without any input to the tube. To overcome an erroneous reading of this nature, a variable bias is applied to the cathode from the junction of resistors R42 and R43 in a voltage divider between the positive 180-volt supply and ground. Resistor R43 is a variable zero-set control adjusted (par. 58) so that tube V2 is just cut off when there is no audio output. Variable resistor R41 is used to adjust the calibration of the PERCENT MODULATION meter.

33. External Modulation

a. Sine-Wave Modulation. Sine-wave modulation at any frequency between 50 and 10,000 cycles may be obtained by connecting an external audio oscillator to the EXT. MOD. jack and turning modulation selector switch S2 to the EXT. position. The modulation circuit now obtains its input voltage from the external generator through EXT. MOD. jack J1, capacitor C25, and the EXT. position contacts of modulation selector switch S2. The external audio oscillator should have a 7- to 10-volt signal output.

b. Pulse Modulation. When EXT. PULSE switch S3 (fig. 24) is turned to the ON position, the plate circuit of the carrier oscillator is switched from the output of the modulator circuit to pulse input jack J2 through resistor R13 and r-f bypass capacitor C7. Since V11 is then deprived of its plate voltage, it will not oscillate unless an external supply is connected to the pulse input jack. The external supply should provide a pulse of 150 volts peak as a minimum.

34. Carrier Oscillator

(fig. 13)

The carrier oscillator section of the signal generator uses an acorn-type triode (V11) in a modified Hartley plate-modulated circuit.

a. The oscillator tank includes one of six r-f coils (L6A through L6F) and a split-stator tuning capacitor (C12). Band switching is controlled by

the range knob and is accomplished by rotating a disk on which the six r-f coils are mounted (fig. 21). Three contacts on each coil assembly mate with three fixed contacts on the capacitor assembly. Detents on the edge of the coil disk engage a spring-loaded detent roller (fig. 20) to accurately position the coil assembly for the desired frequency band. Plate voltage is supplied to the oscillator through the center contact (center tap of the coil assembly). Plate voltage is supplied to bands B through F through dropping resistor R9B, C, D, E, or F, respectively. This resistor is part of the coil assembly.

b. Capacitor C12 tunes the oscillator within each frequency band and is coupled mechanically to the carrier frequency dial. The carrier frequency dial is rotated by the tuning knob which is pivoted to disengage when pressed downward. This permits resetting of the tuning knob zero to correspond to any desired frequency, and is useful for interpolating between frequency calibrations (par. 16). It is impossible to force the tuning mechanism when the stop is reached since the tuning knob will automatically jump down and slip. The resulting jumpy action indicates that the usable portion of the range has been passed. No moving contacts are used in the tuning capacitor, and the rotor is insulated from ground. Spring-loading of the tuning reduction gears provides smooth operation with a minimum of dial backlash. Capacitor C11 is the grid d-c blocking capacitor for tube V11.

c. The modulated voltage from tube V2 in the modulator circuit (or the output of an external pulse generator) is fed to the plate of V11. Leakage from the carrier oscillator to the plate supply is prevented by five-section filter choke coils L1, L2, L3, L4, and L5; resistors R12 and R14; and bypass capacitors C5, C6, C8, C9, and C10. Each section of this filter is isolated within a separate shield. R-f chokes L1 and L2 are in a two-section can; L3, L4, and L5 are r-f choke coils wound on ceramic coil forms and are located between the inner and outer shields (fig. 24).

d. The filament supply of B11 (fig. 13) is filtered in the same manner as the plate supply. The three-section filter is comprised of choke coils L7, L8, and L9 and bypass capacitors C13, C14, C15, C16, C31, and C32. R-f chokes L7 and L8 are in a two-section can (fig. 13). L9 is a single-section r-f choke wound on a polystyrene coil form and is located between the inner and outer shields. Re-

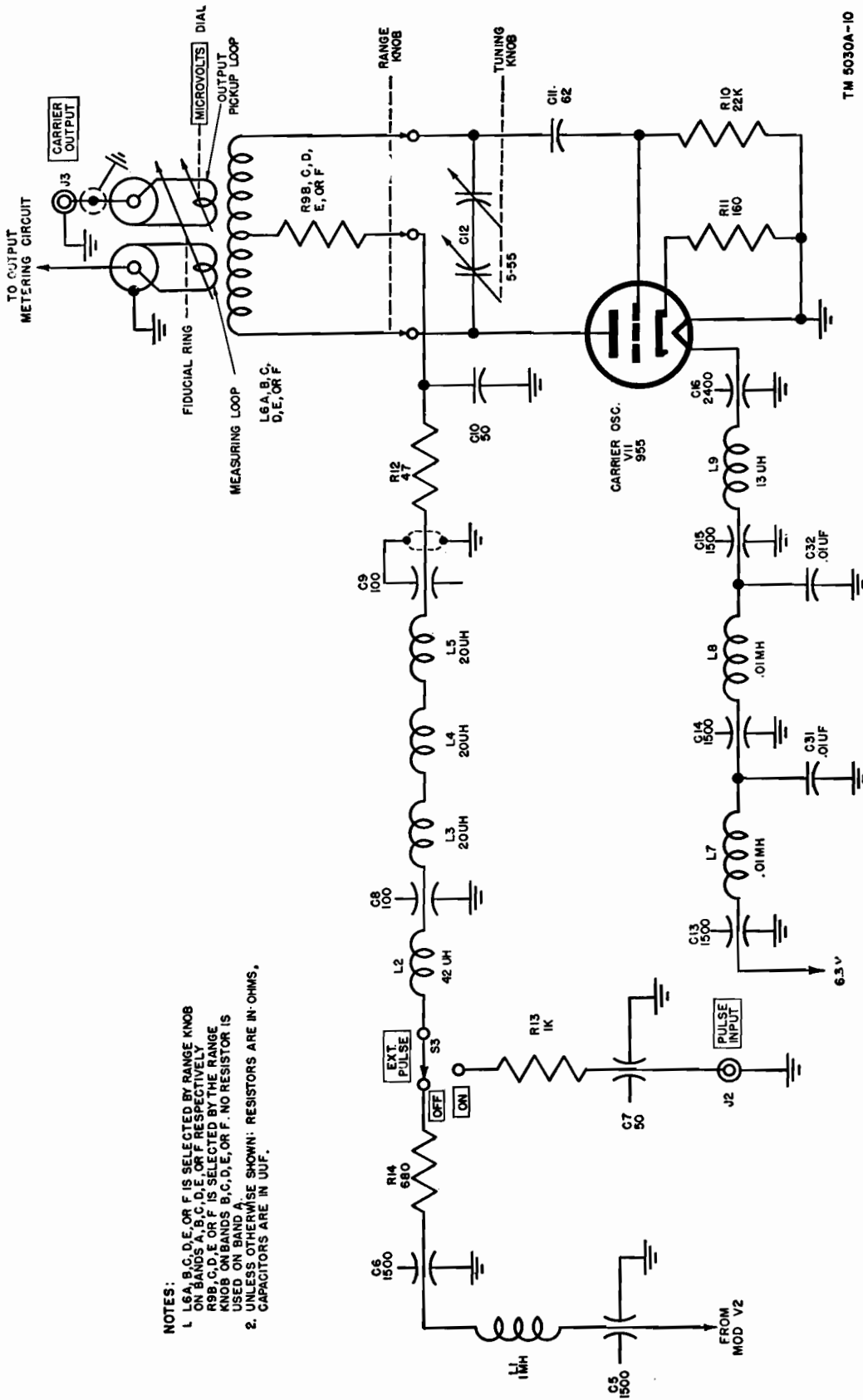

TM 5030A-10

Figure 13. Carrier oscillator schematic.

sistor R11 provides cathode bias in addition to minimizing the effects of cathode lead inductance. Resistor R10 provides grid bias.

e. Output from the oscillator tank is supplied to CARRIER OUTPUT jack J3 (fig. 13) and to an output metering circuit through a variable piston-type attenuator (par. 35).

35. Carrier Output Circuit

a. The variable piston-type attenuator used to couple the oscillator output to CARRIER OUTPUT (fig. 14) jack is of the mutual inductance type. It consists of three concentric metal tubes and a length of coaxial cable that runs down the center tube. The outer tube is fixed in position and is grounded. It serves as a guide within which the other tubes are free to move axially. The middle tube carries the measuring pickup loop (fig. 15) and measuring crystal rectifier V10. The middle tube is driven by the fiducial ring (fig. 14) through a mechanical linkage (special wire cable). The inner tube carries the output pickup loop to

which is connected the coaxial cable that runs through the center of the inner tube and to CARRIER OUTPUT jack J3. The inner tube is driven by the MICROVOLTS dial through a mechanical linkage (special wire cable). Both pickup loops are in the field of the oscillator tank coil.

b. As the MICROVOLTS dial is turned, the inner tube carrying the output pickup loop is moved linearly closer to, or farther away from, the oscillator coil. As the spacing between the output pickup loop and the oscillator coil changes linearly, the voltage induced in the pickup loop changes in a logarithmic fashion. This induced voltage is made available at CARRIER OUTPUT jack J3.

36. Output Metering System

a. Since the linear movement of the output pickup loop results in a logarithmic change in carrier output voltage, a logarithmic scale is used on the MICROVOLTS dials. If one calibration can

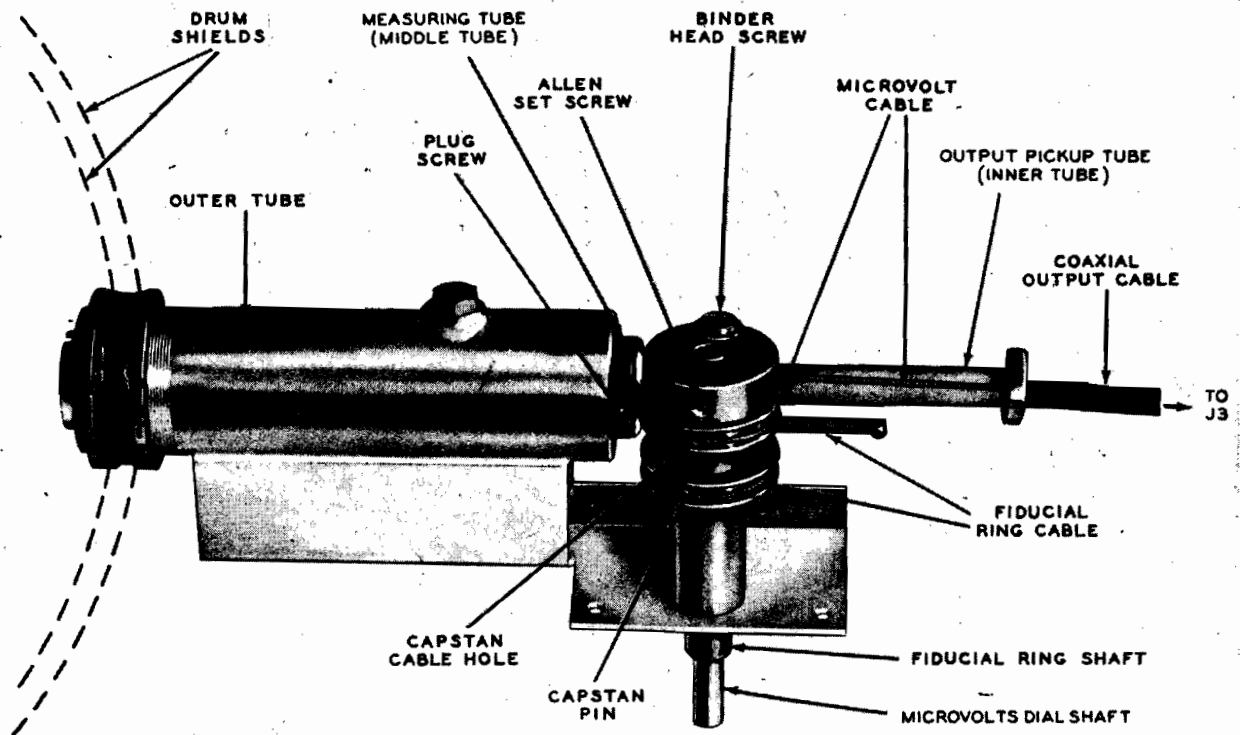

TM 5030A-23

Figure 14. Piston attenuator.

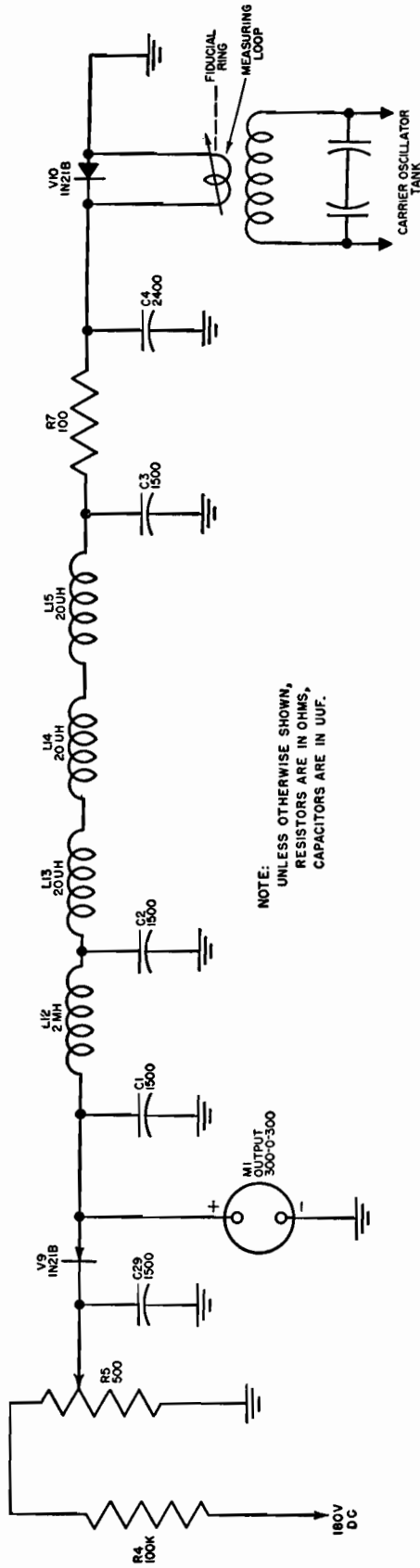

Figure 15. Output metering schematic.

be determined accurately, the others will be equally reliable. However, since the carrier oscillator output, and the voltage induced in the output pickup loop at any one position, may vary from band to band and from frequency to frequency within a single band, a single fixed calibration cannot be used; it is necessary to establish the accuracy of calibration at each frequency.

b. The essential elements of the metering circuit include a measuring pickup loop in the field of the oscillator coil, a crystal diode that rectifies the r-f voltage, and a meter that indicates the output.

c. The measuring pickup loop is mounted on the middle tube, which is concentric with the center (output) and fixed outer tubes. The fiducial ring on the front panel controls the position of the measuring tube and the position of the measuring loop relative to the oscillator coil.

d. Since the attenuator and measuring loops move linearly, with respect to the oscillator coil, the voltage induced in the output pickup loop may be determined for any position of the MICRO-VOLTS dial, if the measuring loop output and the relative position of the two loops are known. The output of the measuring loop is supplied to a crystal diode where it is rectified and passed on to the OUTPUT meter.

e. The measuring crystal, V10, is mounted on the measuring tube. It is coupled closer to, or farther from, the oscillator coil by rotating the fiducial ring. Any change in the position of the fiducial ring will be reflected in the reading of the OUTPUT meter. To establish the correct reference mark on the fiducial ring, it is necessary to calibrate the equipment with an external barretter

bridge (par. 61). Coils L12 through L15 (fig. 15) are r-f filters for the measurement circuit. Capacitors C1 through C4 are r-f bypass filters for the measurement circuit. The temperature-compensating crystal, V9, is located outside the double shields at the bottom rear of the front panel. Since crystal diodes have a poor efficiency at low signal levels, such as $50\text{K } \mu\text{V}$, a d-c bias is applied to the measuring crystal so that it operates over a more efficient part of its characteristic curve. Also, the rectification efficiency of crystal diodes changes with ambient temperature. To overcome this characteristic, the d-c bias voltage is applied to the measuring crystal through a compensating crystal which automatically changes the bias with temperature, to maintain the proper operating condition of the measuring crystal. The d-c bias is supplied from the regulated 180 volts through adjusting output metering set potentiometer R5 and dropping resistor R4. OUTPUT meter M1 is a zero-center meter that reads the difference between the d-c bias voltage and the rectified r-f voltage. When these are equal the meter reads at the red line. The design of the meter is such that it has a nonlinear characteristic with the maximum deflection sensitivity in the center of the scale. In addition to providing increased center-scale sensitivity, this design protects the meter pointer from damage caused by hitting the stops at each end of the meter scale.

37. Power Supply

(fig. 16)

a. The a-c voltage required for operation is supplied from an external source through fuse F1 and

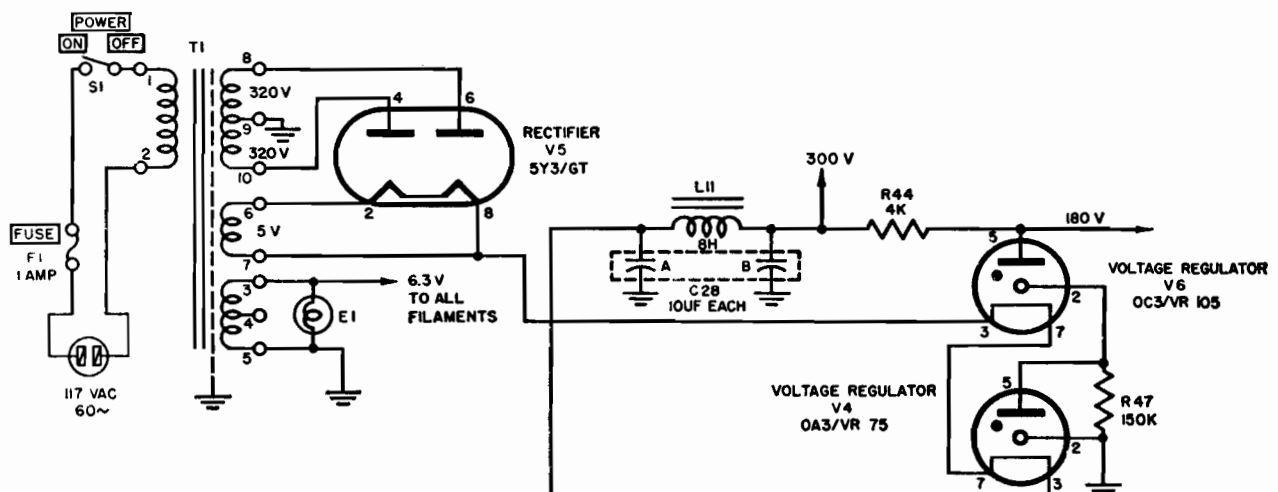

Figure 16. Power supply schematic.

TM 5030A-12

POWER switch S1, to the primary winding of transformer T1. Transformer T1 has three secondary windings. A 6.3-volt secondary winding supplies voltage for the filaments of pilot lamp E1 and all vacuum tubes except V5. A 5-volt winding supplies the filament voltage to rectifier tube V5. An h-v (high-voltage) winding is connected to the two plates of tube V5. This tube rectifies the a-c voltage to a pulsating d-c which is smoothed out by filter capacitors C28A and C28B and choke L11. A 300-volt d-c output from

the filter is supplied to the plate of tube V1 through voltage dropping resistors R8 and R28.

b. Two voltage regulator tubes (V4 in series with V6), in conjunction with current-limiting resistors R44 and R47, regulate a 180-volt supply. The power supply furnishes 300 volts (unregulated), and 180 volts (regulated) for the various tubes used in the signal generator. Voltage regulator tubes V4 and V6 are wired so that removal of either one will cut off the entire plate supply by opening the connection between the rectifier and the filter.

CHAPTER 5

FIELD MAINTENANCE INSTRUCTIONS

Note. This chapter contains information for field maintenance. The amount of repair that can be performed by units having field maintenance responsibility is limited only by the tools and test equipment available and by the skill of the repairman.

Section I. PREREPAIR PROCEDURES

38. Tools, Materials, and Test Equipment

Tools, materials, and test equipment needed for performing the prerepair procedures in this section are listed below:

- Tool Equipment TE-113.
- Wrench, 1 inch flat, open end.
- Solvent, Dry Cleaning (SD), Federal P-S-661a.
- Tube Tester I-177.
- Multimeter TS-352/U.
- Crocus cloth.

39. Removal of Pluck-Out Parts

a. Removing Tubes.

- (1) Remove the 10 screws that hold the panel in the case. Grasp the pull handles on the panel and slide the signal generator out of the case.
- (2) Unscrew lamp E4 and remove it from the socket.
- (3) Remove the tube clamp holding vacuum tubes V4 and V6 in position.
- (4) Remove the vacuum tube shields by pushing them down and turning them counterclockwise.
- (5) Use Tube Puller TL-201 to remove all the tubes located on the power supply chassis. Do not rock the tube if it can be removed by a direct upward pull. If it does not release readily, rock it *gently* to avoid spreading the tube prongs or contacts of the socket. Label each tube as it is removed to assure replacement in its proper socket. (This is necessary for tube V8 since its replacement requires special aging as noted in par. 58.)

- (6) Do not remove carrier oscillator tube VII. For replacement see paragraph 53.

b. Removing Fuses. Two fuseholders labeled FUSE and SPARE FUSE are located on the front panel. Turn the fuseholder cap counterclockwise. The fuse will be extracted with the fuseholder cap.

c. Pilot Lamp E1. Do not remove pilot lamp E1 unless it requires replacement. If replacement is necessary, follow the procedure outlined in paragraph 51.

40. Cleaning, Inspecting, and Testing Removed Parts

a. Cleaning, Inspecting, and Testing Tubes.

- (1) *Cleaning.* Clean the tubes with a cloth moistened with solvent (SD); if necessary, clean the prongs with crocus cloth.
- (2) *Inspection.* Inspect the tubes for cracks in the glass and the base, and for bent or broken prongs.
- (3) *Testing.* Check ballast lamp E4 with an ohmmeter. Resistance should be between 500 and 1,000 ohms. Note that the resistance increases as the filament warms up. Use the tube tester to test the other tubes for short circuits, leakage, and proper emission.

b. Inspecting, Cleaning, and Testing Fuses.

- (1) *Inspecting.* Inspect the fuse ends for evidence of burning, corrosion, and looseness.
- (2) *Cleaning.* Clean the fuse ends with emery cloth and wipe them with a clean cloth. If a file is used to remove deep pits, use crocus cloth to leave a smooth

contact surface and then wipe them dry with a clean cloth.

- (3) *Testing.* Check fuses for continuity with an ohmmeter.

41. Cleaning and Inspecting Interior of Chassis

a. Cleaning. Rest the signal generator on the guard handles. Remove loose dirt and dust from the power supply with a brush or blower; be careful not to hit the attenuator tube or cable assembly. Remove dirt and grease which adheres to the chassis or parts with a brush or cloth moistened with solvent (SD). Do not remove the oscillator drum shields or filter cover when cleaning the power supply chassis.

b. Inspecting. After the chassis has been cleaned carefully, make a visual inspection of parts and wiring for rust, corrosion, loose connection, frayed or burned insulation, loose screws, and charred resistors and coils. Inspect the tube sockets and switches for broken contacts. Inspect terminal boards for broken lugs and signs of burning.

42. Reassembling Signal Generator

Replace the fuses and tubes. If it is necessary to replace tube V8 with a new tube, refer to paragraph 58; a new tube will require aging for about 8 hours and will necessitate recalibration of the PERCENT MODULATION meter. Be sure that all tubes are placed in the correct sockets. Slide the chassis into the case.

Section II. TROUBLESHOOTING AT FIELD MAINTENANCE LEVEL

43. Troubleshooting Procedures

a. General. The first step in servicing the signal generator is to sectionalize the fault. Sectionalization means tracing the fault to the *major component or circuit* responsible for the abnormal operation of the set. The second step is to localize the fault. Localization means tracing the fault to the defective *part* responsible for the abnormal condition. Some faults, such as burned-out resistors, r-f arcing, and shorted transformers, often can be located by sight, smell, and hearing. The majority of faults, however, must be localized by checking voltage and resistance.

b. Component Sectionalization and Localization. The tests listed below aid in isolating the source of trouble. For maximum effect, follow the procedure in the order given. The servicing procedure should cause no further damage to the signal generator. First, the trouble must be localized to a single stage or circuit. Then the trouble may be isolated within that stage or circuit by appropriate voltage, resistance, and continuity measurements. The service procedure is summarized as follows:

- (1) *Visual inspection.* The purpose of visual inspection (par. 27) is to locate any visible trouble. Through this inspection alone the repairman frequently may discover the trouble. This inspection is also valuable in forestalling future failures and in avoiding additional damage which might

occur through improper servicing methods.

- (2) *Power supply resistance measurements.* These measurements (par. 47) prevent further damage to the signal generator from possible short circuits.
- (3) *Operational check.* The operational check (par. 48) is important because it frequently indicates the general location of trouble and nature of the fault. To utilize this information fully all symptoms must be interpreted in relation to one another.
- (4) *Troubleshooting chart.* The trouble symptoms listed in this chart (par. 49) will aid greatly in localizing trouble.
- (5) *Intermittents.* In all the foregoing tests, the possibility of intermittents should not be overlooked. If present, this type of trouble often may be forced to reappear by tapping or jarring the set. This trouble may not be caused by the set itself but by faulty cables or connectors. Check by substituting cables known to be in good working order.

44. Troubleshooting Data

Take advantage of the material supplied in this manual. It will help in the rapid location of faults. Consult the following troubleshooting data:

Fig. or par. No.	Description
Par. 48	Operational test.
Fig. 10	Block diagram.
Fig. 17	Bottom view of chassis, location of parts.
Fig. 18	Tube socket voltage and resistance diagram.
Fig. 19	Dial mechanism, front view.
Fig. 20	Signal Generator TS-497B/URR, inside rear view.
Fig. 21	Oscillator assembly.
Fig. 24	Signal Generator TS-497B/URR, overall schematic.

45. Test Equipment Required for Troubleshooting

The test equipment required for troubleshooting Signal Generator TS-497B/URR is listed below. Available publications for the test equipment also are listed.

Test equipment	Publication
Tube Tester I-177	TM 11-2627.
Multimeter TS-352/U	TM 11-5527.
Barretter bridge (Measurements Corporation #202 or equal).	
Frequency Meter TS-175B/U	TM 11-5050.
Spring scale: 5 to 15 lb.	
Crystal Rectifier Test Set TS-268(*)/U	TM 11-1242.

46. Precautions

a. Never use tools to pry off the oscillator shields. Slight dents in these shields may cause serious leakage of the carrier.

b. Exposed portions of the calibrated carrier frequency dial must be protected against handling. *No liquids should be used for cleaning, since each dial is calibrated individually and liquids might remove the markings.*

c. Do not disturb the adjustment of OUTPUT METER SET control R5 (fig. 17).

d. Careless replacement of parts often makes new faults inevitable. Note the following points:

- (1) Before a part is unsoldered, note the position of the leads. Tag the leads to assure correct replacement.
- (2) Do not allow drops of solder to fall into the set. They may cause shorts.
- (3) Be careful in making soldered connections; faults due to poorly soldered joints are difficult to find.

- (4) When a part is replaced in r-f circuits, it must be placed exactly as the original one was, since a part having the same electrical value but different physical size may cause trouble in h-f (high-frequency) circuits. Give particular attention to proper grounding. Use the same ground as in the original wiring.

47. Power Supply Resistance Measurements

Trouble within the signal generator often may be detected by checking the resistance of the power supply circuit before applying power to the equipment. While the unit is fused, affording protection from shorts, preliminary checks will prevent needless blowing of fuses.

a. The d-c resistance of the input windings of T1 should be approximately 6 ohms.

b. The resistance measurements from B+ to ground is approximately 50,000 ohms. This measurement can be made readily between a terminal of coil L11 (fig. 24) and the chassis.

- (1) If the resistance is zero or unusually low, check the h-v wiring and filter capacitors C28A and C28B.
- (2) If the resistance is low, check for a shorted bypass capacitor or a shorted wire in one of the plate or screen grid circuits.
- (3) If the resistance is higher than normal, check R34, R35, R36, R42, R43, R44, and R46 for continuity. The voltage and resistance chart (fig. 18) will aid in checking for the correct resistance values.

48. Operational Test

a. Connect the power plug to the a-c source and turn on the power. Note whether the carrier frequency dial is illuminated.

b. Turn the EXT. PULSE switch and the modulation selector switch to OFF.

- (1) If the PERCENT MODULATION meter shows a reading when the modulation selector switch is at OFF, the trouble may be due to a filament to cathode short (or leakage) in carrier oscillator tube V11.
- (2) Turn the EXT. PULSE knob to ON. If the PERCENT MODULATION meter returns to 0, the trouble is definitely due to a short circuit in V11.

c. Set the OUTPUT meter pointer to the red line by means of the fiducial ring. Rotate the

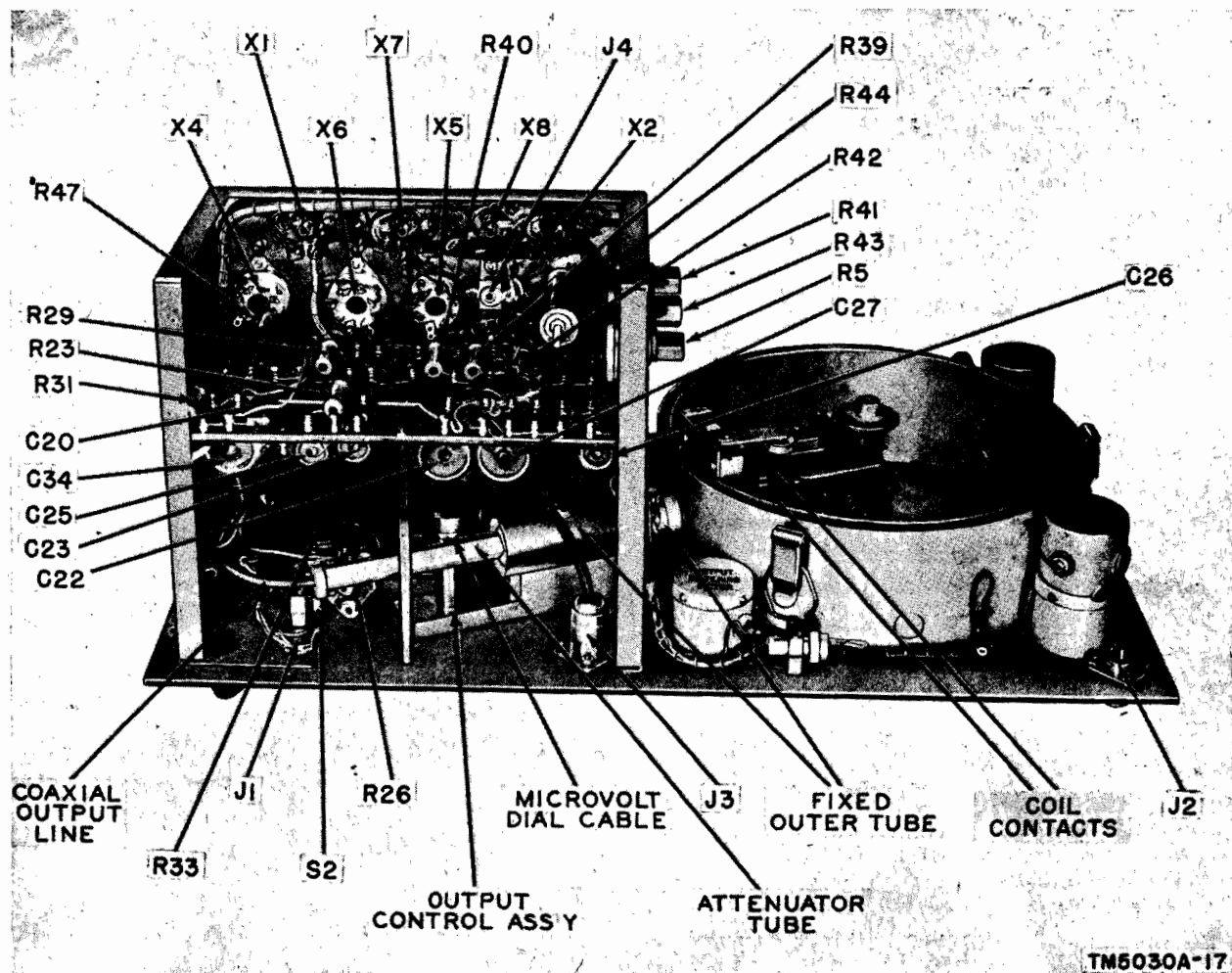

Figure 17. Bottom view of chassis, location of parts.

tuning knob and note whether it is possible to set the meter pointer to the red line over the entire range. If not, the following checks will aid in sectionalizing the trouble:

- (1) If the OUTPUT meter reads midway between the left and center marks and does not respond to adjustments of the fiducial ring, check all of the ranges successively.
- (2) If some ranges are normal, note those which do not respond to adjustments of the fiducial ring. Refer to paragraph 54 for replacing defective oscillator coils.
- (3) If the OUTPUT meter remains fixed on *all* ranges when turning the fiducial ring, turn the EXT. PULSE switch ON and OFF.
- (4) If no change occurs on the OUTPUT meter, turn the modulation selector

switch to 400; turn the PERCENT MOD. control until the PERCENT MODULATION meter reads 20 percent; and again turn the EXT. PULSE switch ON and OFF. If a drop occurs in the PERCENT MODULATION meter when the EXT. PULSE switch is ON, it may be assumed that the carrier oscillator is working properly.

d. Turn the PERCENT MOD. knob to the extreme counterclockwise position. Set the modulation selector switch at 400. Turn the PERCENT MOD. knob until the PERCENT MODULATION meter reads 30 percent. The OUTPUT meter should deflect to the right of the red line as modulation is applied.

- (1) If there is no deflection of the PERCENT MODULATION meter, notice whether the OUTPUT meter deflects to

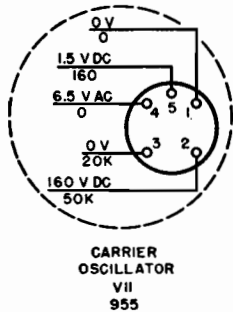
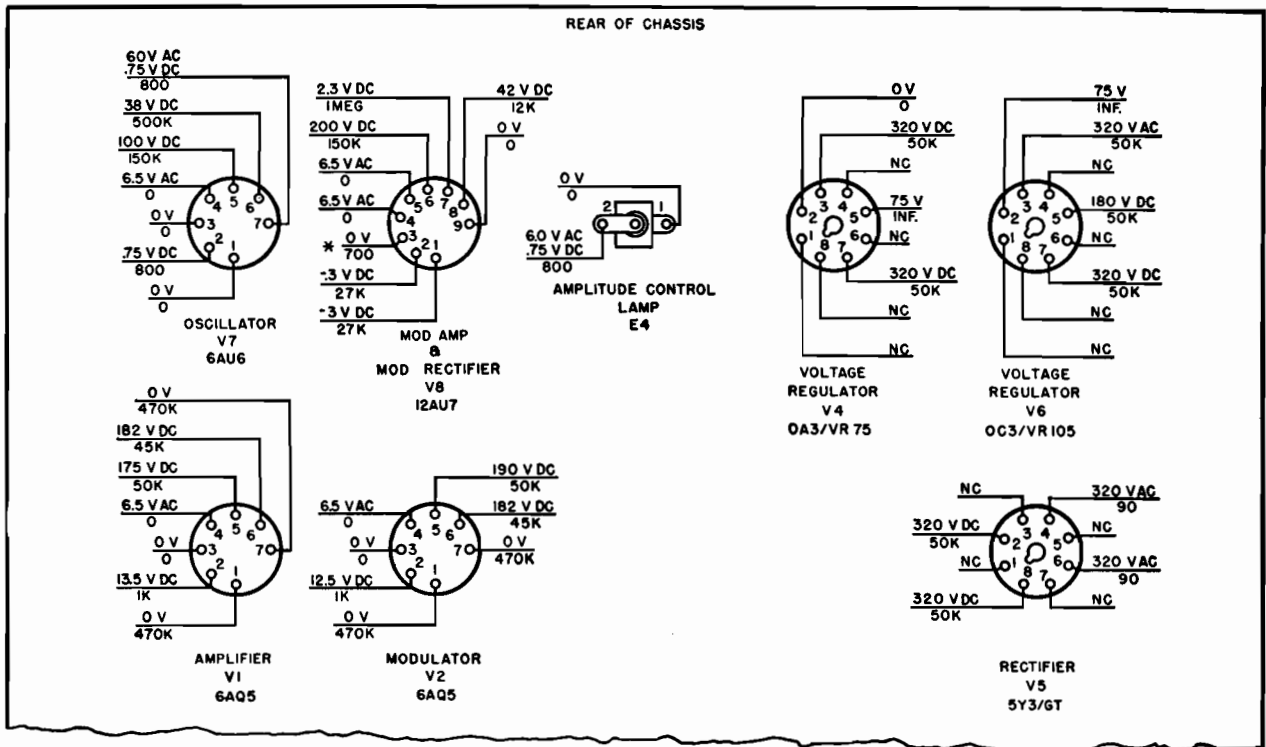

- NOTES:
1. ALL VOLTAGES ARE MEASURED TO GROUND AND ARE DC UNLESS INDICATED OTHERWISE.
 2. NC INDICATES NO CONNECTION.
 3. D-C VOLTAGE MEASURED WITH 2000 Ω /VOLT METER.
 4. A-C VOLTAGE MEASURED WITH 1000 Ω /VOLT METER.
 5. RESISTANCE MEASUREMENTS ARE MEASURED TO GROUND.
 6. * DEPENDS ON SETTINGS OF R41 AND R43.
 7. VOLTAGE READINGS ABOVE LINES, RESISTANCE READINGS BELOW LINES.

TM 5030A-18

Figure 18. Tube socket voltage and resistance diagram.

the right with increased modulation. Deflection of the OUTPUT meter indicates that the modulation circuits are functioning normally.

- (2) If the OUTPUT meter does not deflect to the right, replace tube V8 with a new 12AU7 vacuum tube. If there is no improvement, be sure to restore the original tube to its socket.
- (3) If a new tube V8 is required, it must be aged for about 8 hours before recalibrating (par. 58).

e. Turn the modulation selector switch to 1000. The PERCENT MODULATION meter should return to 30 percent without further adjustment of the PERCENT MOD. knob.

f. Set the MICROVOLTS dial for a fairly high modulated carrier output. If the OUTPUT meter and the PERCENT MODULATION meter readings appear normal, but no carrier output is obtained, make the following checks:

- (1) Check all the cables and external equipment by substituting equipment known to be in working condition.
- (2) Measure the resistance from the center conductor of CARRIER OUTPUT jack J3 to ground. This resistance will be zero unless the output pickup coaxial line is broken. If it is broken, resistance will be infinite.
- (3) With the carrier output cable disconnected from the CARRIER OUTPUT

jack, set the MICROVOLTS dial to 100K and tune the carrier oscillator slowly between 330 and 340 mc on the F band. At some point, a dip in the OUTPUT meter reading should occur. At this point, shorting the CARRIER OUTPUT jack should cause a considerable rise in the OUTPUT meter read-

ing. This indicates that the attenuator line is not shorted internally and further check of the carrier output connections must be made.

49. Troubleshooting Chart

The following chart is supplied as an aid in locating trouble in the signal generator.

Symptom	Probable trouble	Correction
1. Dial lamp does not light. No meter indication.	1. Shorted filter capacitor C28A or C28B; grounded filament lead.	1. Replace faulty capacitor; clear short.
2. No carrier output, or meter indication other than 10 percent on PERCENT MODULATION meter.	2. Plate supply V11 shorted.	2. Isolate with ohmmeter and clear short.
3. No carrier output at CARRIER OUTPUT jack; meters operate properly.	3. Shorted CARRIER OUTPUT jack caused by using a connector with projecting center pin.	3. Replace connector and open output receptacle to clear short.
4. OUTPUT METER cannot be set to red line.	4. Output circuit calibration out of adjustment.	4. Reset (par. 61).
5. PERCENT MODULATION meter reads slightly off zero.	5. Variation in value of circuit elements caused by heat.	5. Reset R43 (% MOD ZERO SET) through hole in rear of power supply chassis.
6. OUTPUT meter pointer cannot be set to red line on one range only.	6. Oscillator coil or resistor on that range open.	6. Replace (par. 54).
7. OUTPUT meter pointer cannot be set to red line on two or more frequency ranges.	7. Tube V11 weak or defective.	7. Replace (par. 53).
8. Fiducial ring turns loosely without affecting OUTPUT meter indication.	8. Fiducial ring cable broken.	8. Replace (par. 57).
9. MICROVOLTS dial turns loosely without controlling carrier output voltage.	9. MICROVOLTS dial cable broken.	9. Replace (par. 56).
10. PERCENT MODULATION meter shows deflection with modulation selector switch at OFF.	10. Filament to cathode short in tube V11.	10. Replace (par. 53).

Section III. REPAIRS

50. General

Most of the electrical components in the power supply and modulator are readily accessible and are replaced easily if they are found to be faulty. To avoid errors where replacements are made, tag each wire when removing a part. Observe the precautions outlined in paragraph 46.

51. Dial Lamp Replacement

To replace the dial lamp, it is necessary to remove the dial cover. Refer to figure 19 for location of parts and use the following procedure:

a. Turn the range knob until band A appears in the window above the knob.

b. Remove the range knob by loosening the two No. 10 Allen setscrews.

c. Remove the tuning knob by loosening the two No. 8 Allen setscrews.

d. Remove the four screws from the corners of the dial cover and lift it off.

e. Remove the dial lamp and replace it with one of the same type.

f. Loosen the nut that secures the lamp holder and adjust the holder with the lamp touching the edge of the fiducial so that the lamp filament is aligned with the frequency reference line.

g. Replace the dial cover and check to see that band A has sufficient illumination. Replace the

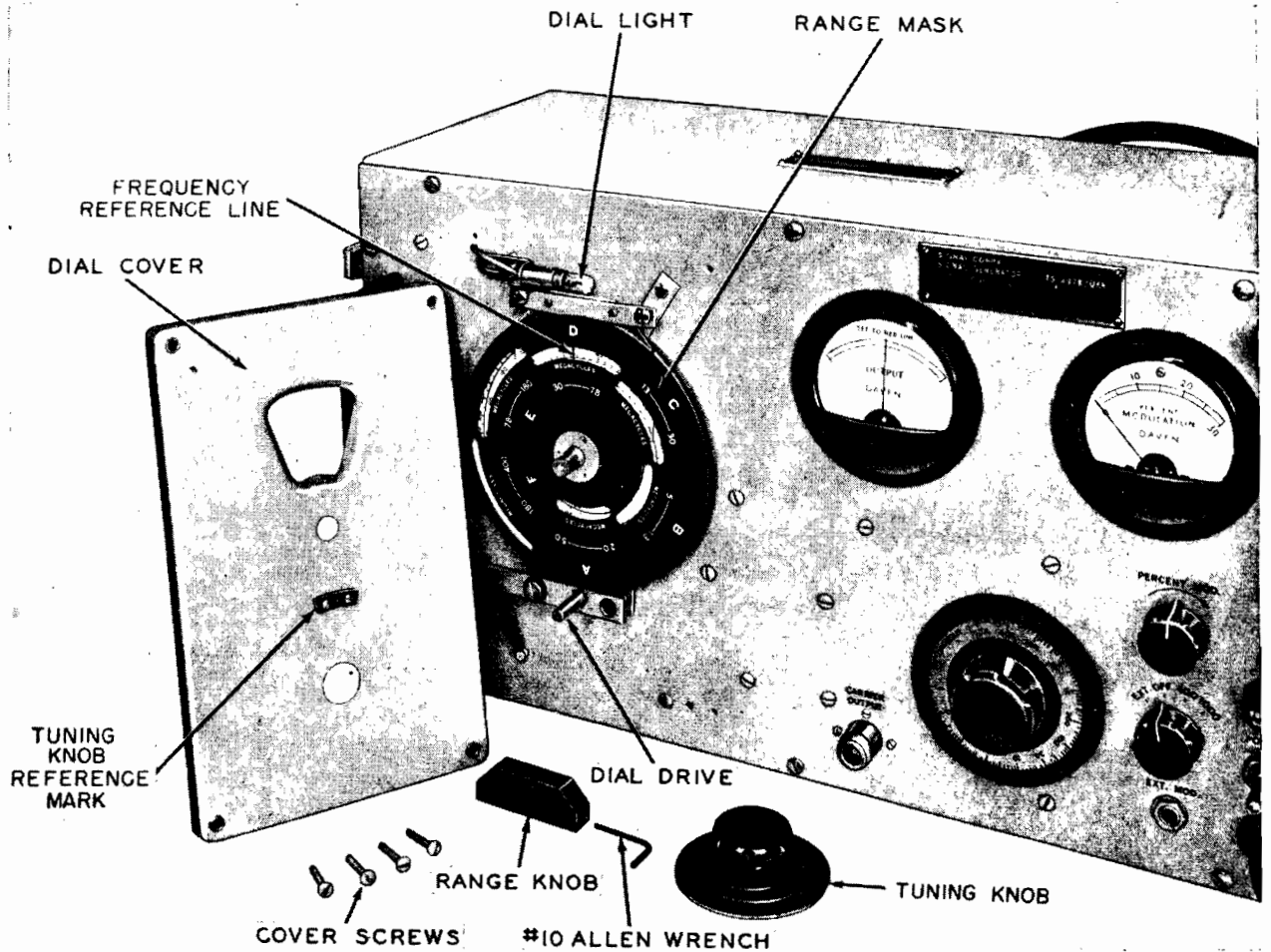

Figure 19. Dial mechanism, front view.

tuning knob. Before tightening the dial cover screws, adjust the dial cover so that the tuning knob just clears the tuning knob reference mark and rotates freely.

h. Replace the range knob and tighten the set-screws on both knobs.

52. Removal and Replacement of Shields and Coil Disk

a. *Drum Shields.* When it is necessary to remove or replace the carrier oscillator drum shields, follow the procedures outlined in (1) through (3) below:

- (1) Carefully unlatch the three shield clamps. Remove the outer and inner shields. Never use tools to pry off these shields since slight dents may cause serious leakage of the carrier.

- (2) When replacing the inner shield, it must be positioned so that the grounding wiper lies adjacent to the roller spring (fig. 20).
 - (3) Replace the outer shield and latch.
- b. *Coil Disk Removal.* With the drum shields removed, remove the coil disk in the following manner:

- (1) Remove the lower screw from the roller spring bracket. This screw is nearest to the roller spring (fig. 20).
- (2) Unscrew the upper screw about $\frac{1}{4}$ inch (2 turns). Remove the roller from the spring. The roller is held in position by the pressure of the spring.
- (3) Push the spring to the left far enough to clear the coil disk.
- (4) Rotate the coil disk to place the detent roller midway between two detents.

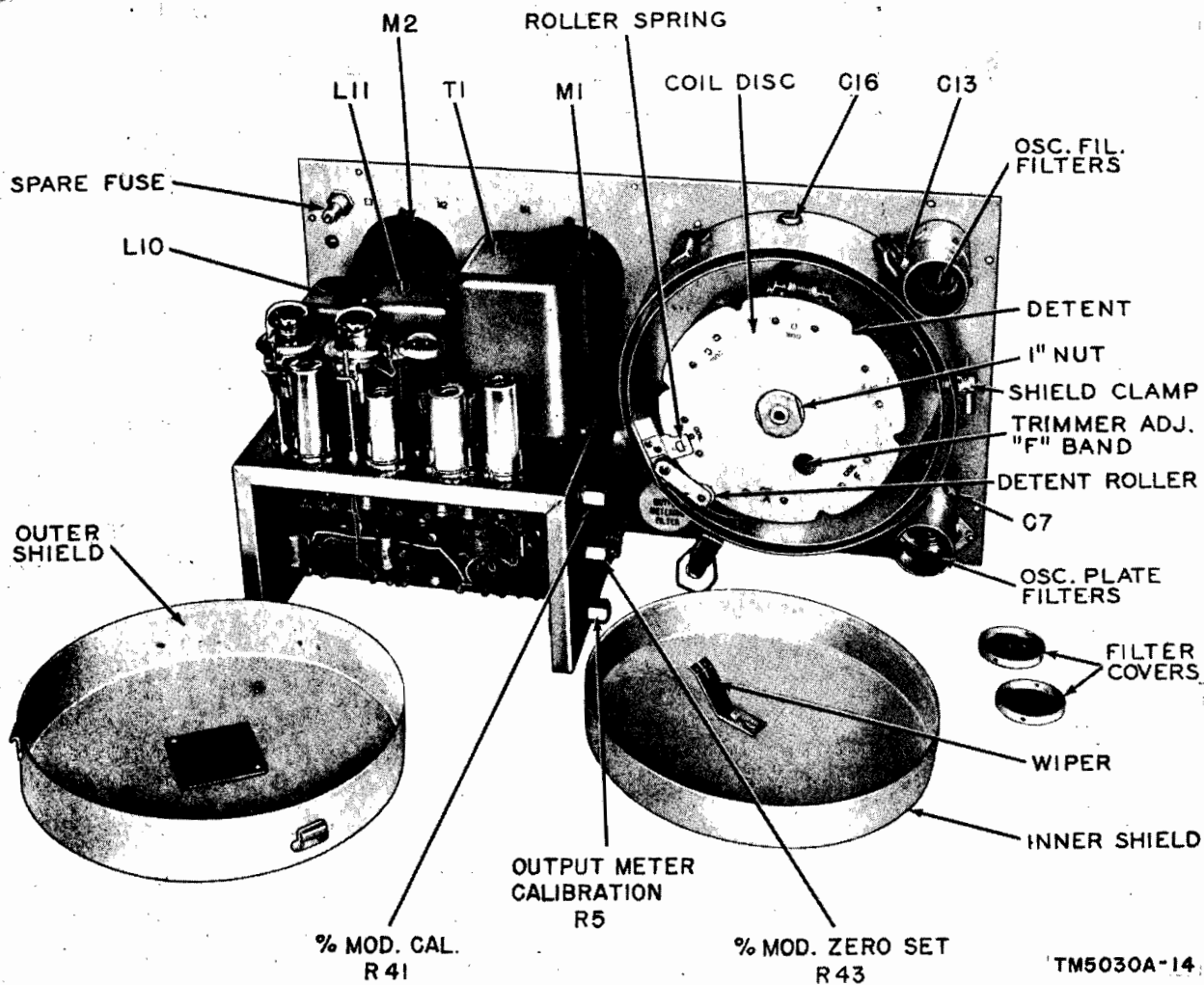

Figure 20. Signal Generator TS-497B/URR, inside rear view.

- (5) Grip the coil disk firmly with one hand and remove the retaining nut with a 1-inch flat open-end wrench.

Caution: Do not let the disk slip; the coil contacts may be damaged.

- (6) Hold the detent roller away from the disk and carefully lift the coil disk assembly from the hub.

c. Replacement of Coil Disk.

- (1) Retract the detent roller; be sure that its spring is engaged. Lower the coil disk in position to engage the flattened position of the hub. Release the detent roller against the supporting bushing.
- (2) Replace the retaining nut and tighten it firmly.

- (3) Replace the roller in the roller spring and push the spring into position.
- (4) Insert the lower screw in the roller spring and tighten both screws.

Caution: Do not rotate the coil disk before visually checking the alignment of the three coil contacts with respect to the contact posts on the capacitor assembly C 12 (fig. 21). Misalignment of these coil contacts, caused by improper seating of the coil disk on its bushing, will cause serious damage to the contacts.

53. Replacement of Carrier Oscillator Tube

The carrier oscillator tube, V11, is located on the side of the capacitor assembly, C12, (fig. 21). Replace as follows:

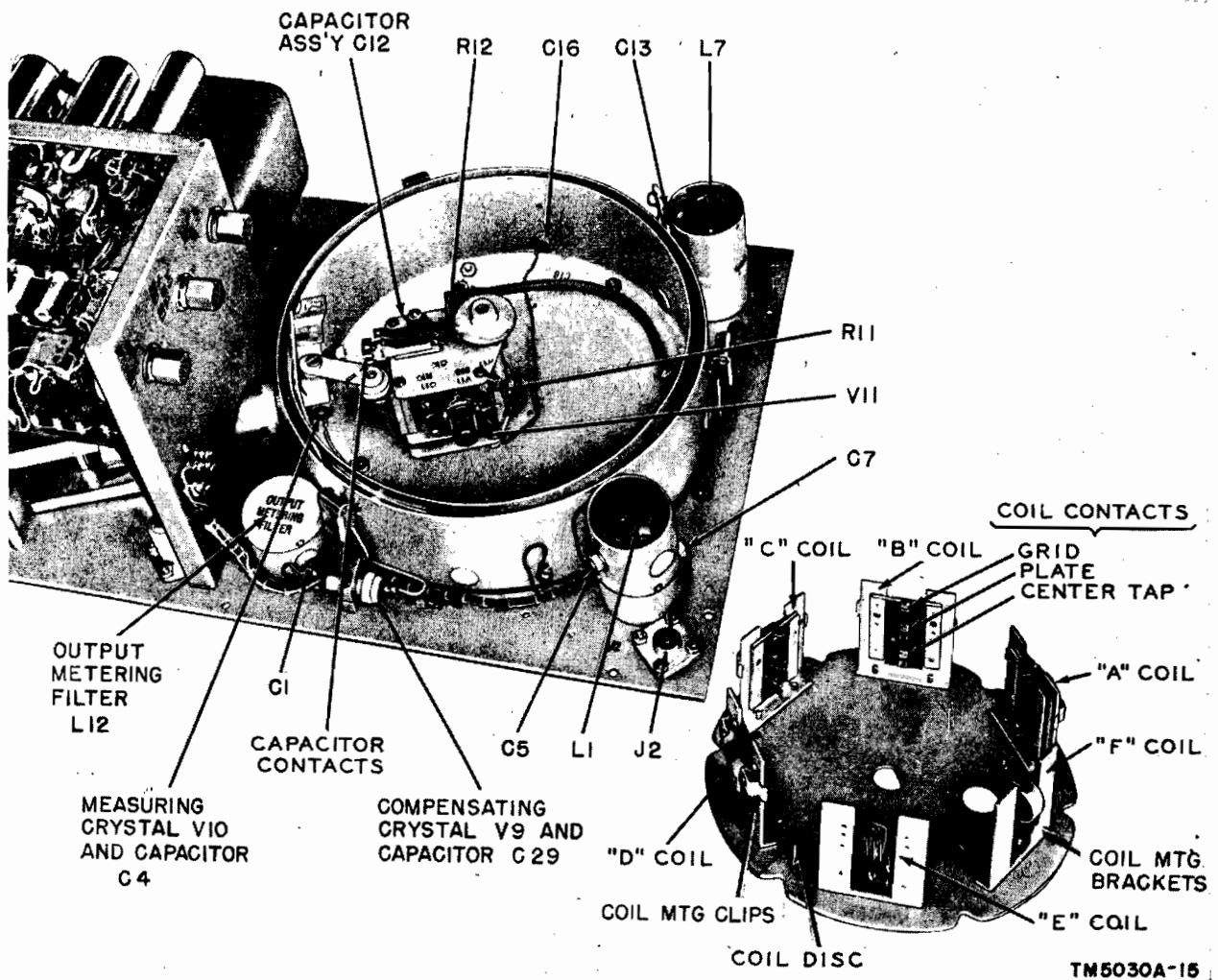

Figure 21. Oscillator assembly.

- a. Remove the drum shields and coil disk (par. 52).
- b. Withdraw the cathode connector from the cathode pin. (Pull the connector straight and do not twist it.)
- c. Remove the acorn-type tube with a sharp counterclockwise twist.
- d. Insert the new tube so that the three-pin side of the tube is on the cathode connector side of the tube socket. Carefully align the pins before easing them into their contacts.
- e. Replace the cathode connector.
- f. Replace the coil disk and drum shields (par. 52).

54. Replacement of Oscillator Coils

A defective oscillator coil can be removed without removing the entire disk assembly.

- a. Remove the drum shields (par. 52).
- b. Rotate the disk so that the defective coil can be reached with the fingers.
- c. Remove the two retaining screws which hold the coil mounting clips of the defective coil (figs. 20 and 21). In most cases, a defect in any part of the coil assembly will require replacement of the entire assembly.
- d. Install the new coil assembly and tighten the screws.

Caution: Be sure that coil leads are not lying against metallic parts of the coil bracket.

e. After replacing a coil, align it in accordance with paragraph 60.

f. Replace the drum shields.

55. Replacement of Crystals

a. The measuring crystal V10 (fig. 21) can be replaced in the following manner:

- (1) Remove the drum shields and coil disk (par. 52).
- (2) Unscrew the crystal holder cap which contains bypass capacitor C4. The holder is mounted on the attenuator measuring tube.
- (3) Remove the crystal by pulling it straight out.
- (4) Replace the crystal and capacitor cap.
- (5) Check the pickup lead from the crossbar of the middle tube for a possible short after replacement of the crystal.

b. The compensating crystal can be replaced in the following manner:

- (1) Unscrew the cap containing bypass capacitor C29.
- (2) Remove the crystal by pulling straight out.
- (3) Replace the crystal and capacitor cap.
- (4) Check the pickup lead from the holder for a possible short after replacement.

c. After replacement of either the measuring or compensating crystal, recalibrate the output circuit in accordance with paragraph 61.

56. Replacement of MICROVOLTS Dial Cable (fig. 14)

The measuring tube (middle tube) and the output pickup tube (inner tube) are moved in and out of the fixed outer tube by means of two separate cables which are looped around capstans. These capstans are rotated independently by the fiducial ring and the MICROVOLTS dial. If either cable breaks in service, replace it with wire that is identical with that which is removed, or wire of the same diameter; otherwise, the incremental reading of the MICROVOLTS dial will be in error. This cable must be prestretched for 8 hours by suspension from a clamp with a 12-pound weight attached to the free end by means of another clamp. Apply the weight gradually to avoid damaging the cable. For the following directions, the end of the attenuator toward the oscillator coils will be designated the front end,

and the opposite end, the rear end. Replace the MICROVOLTS dial cable as follows:

a. Remove the drum shields (par. 52).

b. Remove the coil disk assembly (par. 52).

c. Unsolder the end of broken cable at the rear end of the inner tube.

d. Remove the binder-head screw from the rear capstan. Rotate the MICROVOLTS dial until the Allen setscrew can be loosened. Remove the rear section of the capstan.

e. Remove the small screw in the depression of the front section of the capstan, and pull the cable out of the hole.

f. Withdraw the square tube as far as possible and push the cable back into the hole about $\frac{3}{8}$ inch. Push the square tube in as far as possible and extract the broken cable from the front end of the attenuator.

Note. Before cutting the cable, tin a small portion and cut it in the center of that section. This will prevent the cable from fraying.

g. Cut off about 15 inches of the prestretched cable. On one end, fold back $\frac{1}{8}$ inch of the cable. Press the folded portion together and solder it. This will form an enlarged end similar to the one removed.

h. Withdraw the square tube as far as possible to the rear. Thread a piece of copper wire, approximately the same size as the cable, through the cable holes of the attenuator. Butt-solder the front end of this wire to the unbent end of the cable. Make a smooth joint so that it will slide through the cable holes.

i. Pull the rear end of the copper wire until the cable passes through the cable holes and the front end seats in the depression at the front of the measuring tube. Unsolder the copper wire.

j. Pass the cable around the capstan once, down through the cable hole, around the screw, and back up through the hole. Adjust the position of the cable on the capstan until the cable hole is closest to the inner tube. The rear end of the tube is approximately $3\frac{7}{8}$ inches away from the hole. Tighten the screw in the capstan to hold the cable in position.

k. Place the free end of the cable in the slot at the rear of the inner tube. Stretch the cable to a tension of 7 pounds, as measured with a spring scale, and solder it. Trim off the excess cable.

l. Replace the rear portion of the capstan but do not tighten the setscrew. Rotate the fiducial ring clockwise to bring the measuring tube in toward

the oscillator capacitor. Push the inner tube in carefully by hand until the output pick-up loop (a straight piece of $\frac{1}{16}$ -inch diameter wire across the inner tube) is exactly in line with the measuring loop. They should appear as one continuous line.

m. While holding the two loops in alinement, turn the MICROVOLTS dial clockwise to stop at 100K and tighten the binder head screw in the rear portion of the capstan.

Caution: Never allow the measuring or output pickup loops to come in contact with an oscillator coil when making hand adjustment of these tubes.

n. Check the operation of the MICROVOLTS dial and if it is satisfactory, replace the coil disk and drum covers.

57. Replacement of Fiducial Ring Cable

Follow the same procedure for prestretching the cable as in paragraph 56.

a. Remove the drum shields (par. 52).

b. Unsolder the rear end of the broken cable.

c. Unsolder the cable from the capstan pin (fig. 14) and remove the excess solder.

d. Withdraw the measuring tube until the two screws which secure the plug in the end of the tube can be removed. Withdraw the plug and push the cable out.

Note. Before cutting the cable, tin a small portion and cut it in the center of that section. This will prevent the cable from fraying.

e. Cut off about 9 inches of the prestretched cable. On one end, fold back $\frac{1}{8}$ inch of the cable to form an enlarged end similar to the one removed. Press this end together and solder it.

f. Feed the cable through the hole in the plug and replace the plug and screws.

g. Observe the front end of the attenuator and, at the same time, carefully push the measuring tube by hand toward the oscillator assembly.

h. Select the A band and carefully adjust the measuring tube until there is about $\frac{1}{32}$ -inch clearance between the measuring loop and the A band coil.

i. Turn the fiducial ring clockwise to the stop.

j. Loop the dial cable once around the fiducial ring capstan. Be sure it lays in the groove of the soldering pin, and pull it to a tension of 7 pounds while soldering the free end of the cable to the rod in the identical manner to the one removed. Be careful not to disturb the position of the measuring tube or fiducial ring during this operation.

k. Solder the cable to the capstan pin as it was previously.

l. Check the operation of the attenuator and replace the drum shields.

Section IV. CALIBRATION PROCEDURE

58. PERCENT MODULATION Meter

Since tube V8 functions as a meter rectifier, it must be replaced with a tube that has been aged for about 8 hours. The filament of the tube must be energized for this period of time in order to stabilize the emission before checking or recalibrating the meter. To do this, place the tube in its socket and energize the signal generator for the required period. Calibrate the meter as follows:

a. With the modulation selector switch in the OFF position, connect a high resistance d-c voltmeter between Capacitor C5 (fig. 21) and the chassis. Multiply the value obtained (approx. 175 volts) by the factor 0.212. Remove the d-c meter.

b. Connect a high-impedance a-c voltmeter, adjusted to read approximately 35 volts, in series with a 0.5- μ f (microfarad) capacitor between Capacitor C5 and the chassis. Turn the modula-

tion selector switch to 400. Adjust the PERCENT MOD. control until the a-c voltmeter reads the value obtained in *a* above (the d-c voltage multiplied by 0.212). Note the reading of the PERCENT MODULATION meter.

c. Adjust R41 (fig. 20) (% MOD CAL) until the PERCENT MODULATION meter reads slightly less than 30 percent.

d. The PERCENT MODULATION meter zero must be reestablished by switching the modulation selector switch to OFF and setting the meter to 0 by means of R43 (% MOD ZERO SET).

e. The procedures outlined in subparagraphs *c* and *d* above are interdependent. Repeat the procedures to obtain the desired results.

59. Carrier Oscillator Trimmer Adjustment

An oscillator trimmer adjustment is provided to compensate for frequency errors which may oc-

cur after carrier oscillator tube V11 is changed. Use an external crystal frequency meter such as Frequency Meter TS-175 B/U covering the frequencies between 300 and 400 mc and proceed as follows:

a. Connect the signal generator output to the frequency meter.

b. Set the signal generator to a standard frequency on the **F** range.

c. Insert a 1/4-inch socket wrench through the coil disk hole provided for this calibration (trimmer adjustment **F** band, fig. 20).

d. Adjust the trimmer until the frequency meter indicates that the output of the signal generator is at the same frequency as that indicated on the carrier frequency dial.

60. Oscillator Coil Alinement

When the oscillator coil is replaced, the new coil must be alined with respect to the output and measuring pickup loops. Proceed as follows:

a. Check to see whether the available movement of the fiducial ring is sufficient to bring the pointer of **OUTPUT** meter to the red line. If it is not, loosen the two screws which hold the coil mounting bracket to the coil disk. Move the coil slightly toward the attenuator and away from the coil disk shaft. Realinement of the coils does not affect the output accuracy of the signal generator.

b. Connect a barretter bridge to the **CARRIER OUTPUT** jack.

c. Switch the new coil into operating position and set the **OUTPUT** meter to the red line. Set the **MICROVOLTS** dial to **50K** and measure the actual output on the bridge. In most cases, the output from a new coil will be low. To increase the output, loosen the two screws on the coil mounting clips and make a very small adjustment of the coil. Push the coil away from the coil disk and toward the front panel. A small offset-head screwdriver will enable the screws to be released

and tightened without removing the coil assembly. Coils **E** and **F** do not have these mounting clips. Coil **F** cannot be adjusted. Coil **E** is adjusted by rotating the entire coil on its soldered leads. When the coil is adjusted toward the front panel, carrier output is increased, and the **OUTPUT** meter reading is decreased. When the meter again is brought up to the red line, an additional increase in output occurs. Since the effect of coil adjustment on carrier output is therefore magnified, this alinement process is critical. Adjust the coil position for a **50K** reading on the barretter bridge.

61. Output Circuit Recalibration

Replacement of one or both of the crystals may necessitate restandardization of the output metering system. This is done by readjusting the **OUTPUT METER SET** control (**R5**) (fig. 20) as follows:

a. Connect a barretter bridge to the carrier **OUTPUT** jack.

b. Set **50K** on the **MICROVOLTS** dial to the white line on the fiducial ring.

c. Adjust the fiducial ring until a carrier output of exactly **50K** microvolts (0.05 volt) is indicated on the external barretter bridge.

d. Unscrew the cap nut of **OUTPUT METER SET** control **R5**. This is located on the side of the power supply chassis (fig. 20). Set the screwdriver adjustment so that the **OUTPUT** meter pointer is on the red center line.

e. Recheck this calibration at various frequencies on each band and make a compromise adjustment of **R5**, if necessary. It will not be difficult to obtain carrier output levels within 5 percent unless the measuring equipment is unreliable.

62. Final Checking

After replacement and recalibration of any parts, the signal generator must be given a final operational check (par. 48) before returning the unit to service.

CHAPTER 6

SHIPMENT AND LIMITED STORAGE AND DEMOLITION TO PREVENT ENEMY USE

Section I. SHIPMENT AND LIMITED STORAGE

63. Repacking for Shipment or Limited Storage

The exact procedure in repacking for shipment or limited storage depends on the material available and the conditions under which the equipment is to be shipped or stored. Refer to paragraph 9 and reverse the instructions outlined in that paragraph.

64. Waterproofing and Weatherproofing

Place dehydrating agent, such as silica gel, inside the packing case. Protect the packing case with a waterproof paper barrier. Seal the seams of the paper barrier with waterproof sealing compound or tape. Place the waterproofed container in a padded wooden case. Use excelsior padding between the waterproofed container and the packing case.

Section II. DEMOLITION OF MATERIEL TO PREVENT ENEMY USE

65. General

The demolition procedures outlined in paragraph 66 will be used to prevent the enemy from salvaging or using this equipment. Demolition of the equipment will be accomplished only upon order of the commander.

66. Methods of Destruction

a. Smash. Smash the meters, controls, tubes, coils, switches, capacitors, and transformers; use sledges, axes, handaxes, hammers, crowbars, or heavy tools.

b. Cut. Cut the cords, wiring, and all cables; use handaxes, axes, or machetes.

c. Burn. Burn cords, resistors, capacitors, coils, wiring, and technical manuals; use gasoline, kerosene, oil, flame throwers, or incendiary grenades.

d. Bend. Bend the panel, cabinet, and chassis.

e. Explosives. If explosives are necessary, use firearms, grenades, or TNT.

f. Disposal. Bury or scatter the destroyed parts in slit trenches, fox holes, or other holes, or throw them into streams.

g. Destroy. Destroy everything.

APPENDIX I

REFERENCES

Note. For availability of items listed, check SR 310-20-3, SR 310-20-4, and SR 310-20-5. Check Department of the Army Supply Manual SIG 1, Introduction and Index, for Signal Corps Supply Manuals.

1. Army Regulations

- AR 750-5 Maintenance of Supplies and Equipment, Maintenance Responsibilities and Shop Operation.
- AR 380-5 Military Security, Safeguarding Security Information.

2. Supply Bulletins

- SR 725-405-5 Preparation and Submission of Requisitions for Signal Corps Supplies.

3. Auxiliary Equipment and Test Equipment

- TM 11-300 Frequency Meter Sets SCR-211-A, B, C, D, E, F, J, K, L, M, N, O, P, Q, R, T, AA, AC, AE, AF, AG, AH, AJ, AK, AL.
- TM 11-303 Test Sets I-56-C, I-56-D, I-56-H, and I-56-J.
- TM 11-321 Test Set I-56-E.
- TM 11-1242 Crystal Rectifier Test Set TS-268(*)/U.
- TM 11-2613 Voltohmmeter I-166.
- TM 11-2624B Voltohmmeters TS-294/U, TS-294B/U, and TS-294C/U.
- TM 11-2626 Test Unit I-176, I-176-A, and I-176-B.
- TM 11-2627 Tube Tester I-177 and I-177-A.
- TM 11-4700 Electrical Indicating and Measuring Instruments, Repair Instructions.
- TM 11-5050 Frequency Meter TS-175B/U.
- TM 11-5527 Multimeter TS-352/U.

4. Painting, Preserving, and Lubrication

- TB SIG 13 Moistureproofing and Fungiproofing Signal Corps Equipment.
- TM 9-2851 Painting Instructions for Field Use.

5. Camouflage, Decontamination, and Demolition

- FM 5-25 Explosives and Demolitions.

6. Other Publications

- SR 310-20-3 Index of Training Publications.
- SR 310-20-4 Index of Technical Manuals, Technical Regulations, Technical Bulletins, Supply Bulletins, Lubrication Orders, and Modification Work Orders.
- SR 310-20-5 Index of Administrative Publications.
- SR 700-45-5 Unsatisfactory Equipment Report (Reports Control Symbol CSGLD-247).
- SR 745-45-5 }
Navy Ship- } Report of Damaged or Improper Ship-
p i n g } ment (Reports Control Symbols
Guide, } CSGLD-66 (Army), SandA-70-6
A r t i c l e } (Navy), and AF-MC-U2 (Air
1850-4 } Force)).
AFR 71-4 }
- TB SIG 25 Preventive Maintenance of Power Cords.
- TB SIG 66 Winter Maintenance of Signal Equipment.
- TB SIG 72 Tropical Maintenance of Ground Signal Equipment.
- TB SIG 75 Desert Maintenance of Ground Signal Equipment.
- TB SIG 123 Preventive Maintenance Practices for Ground Signal Equipment.
- TB SIG 178 Preventive Maintenance Guide for Radio Communication Equipment.
- TB SIG 219 Operation of Signal Equipment at Low Temperatures.
- TM 11-455 Radio Fundamentals.
- TM 11-661 Electrical Fundamentals (Direct Current).
- TM 11-681 Electrical Fundamentals (Alternating Current).
- TM 11-4000 Troubleshooting and Repair of Radio Equipment.

APPENDIX II

IDENTIFICATION TABLE OF PARTS

1. Requisitioning of Parts

The fact that a part is listed in this table is not sufficient basis for requisitioning the item. Requisitions must cite an authorized basis, such as a specific T/O & E, T/A, SIG 7 & 8, list of allowances of expendable material, or another authorized supply basis. The Department of the Army Supply Manual applicable to the equipment covered in this manual is SIG 7 & 8-TS-497/URR. For an index of available supply manuals, in the Signal portion of the Department of the Army Supply Manual, see SIG 1, Introduction and Index.

2. Identification Table of Parts for Signal Generator TS-497B/URR

Ref. symbol	Name of part and description	Function of part	Signal Corps stock No.
	SIGNAL GENERATOR TS-497B/URR: freq range 2-400 mc in 6 band; accuracy $\pm 5\%$ on all ranges.	Provides test signals over a range of 2 to 400 mc.	3F4325-497.
M1	TECHNICAL MANUAL TM 11-5030A-AMMETER: d-c; 300-0-300 μ a; Davenco #6040C.	OUTPUT meter	Order thru AGO. 3F930-45.
M2	AMMETER: d-c; 0-200 μ a; Marion Elec Instr type #HS-3; spcl.	PERCENT MODULATION meter.	3F872-35.
Z1	ATTENUATOR, fixed: resistive type; 5-20 db; Davenco type #RFC-155-50-6.	Fixed impedance matching pad for use with RF plug UG-21B/U.	2Z394.85.
	ATTENUATOR, variable: 50-ohm impedance; Davenco #6107-A.	Varies output of the carrier oscillator.	2Z394.124.
W2	CABLE ASSEMBLY, RF: RF Cable Assembly CG-683/U; uses Radio Frequency Cable RC-58C/U; 4' lg.	Output cable	3E6015-683.1.
W1	CABLE ASSEMBLY, RF: Cord CG-55C/U; Radio Frequency Cable RG-8A/U; 5' lg.	Output cable	3E5999A-1.
W3	CABLE, power: electrical; UL-type SJ cable modified; 2 #18 AWG stranded cond; 8'.	A-c power cable	1B3018-2.28.
	CABLE, RF: RF Cable RG-8A/U; coaxial; 52 ohms; w/o fittings.	Part of cable W1	1F425-8A.
	CABLE, RF: RF Cable RG-58C/U; coaxial; 52 ohms; w/o fittings.	Part of cable W2	1F425-58C.
C7	CAPACITOR, fixed: mica dielectric; 50 μ mf $\pm 5\%$; 1250 vdw; Davenco part #6002A.	Pulse modulation circuit, r-f bypass.	3D9050-172.
C11	CAPACITOR, fixed: mica dielectric; 62 μ mf $\pm 10\%$; 350 vdw; Sangamo type #M-73, part #66633.	Carrier oscillator grid circuit, d-c blocking.	3D9062-14.
C8, C9	CAPACITOR, fixed: mica dielectric; 100 μ mf $\pm 5\%$; 1250 vdw; Sangamo type #M-24.	Carrier oscillator plate circuit, r-f bypass.	3D9100-317

2. Identification Table of Parts for Signal Generator TS-497B/URR—Continued

Ref. symbol	Name of part and description	Function of part	Signal Corps stock No.
C21-----	CAPACITOR, fixed: mica dielectric; 980 $\mu\mu\text{f}$ $\pm 1\%$; 500 vdcw; Electro Motive type #603M.	Frequency control in audio oscillator.	3D9980-7.
C20-----	CAPACITOR, fixed: mica dielectric; 1000 $\mu\mu\text{f}$ $\pm 1\%$; 500 vdcw; Electro Motive type #603M.	Frequency control in audio oscillator.	3DA1-294.
C1, C2, C3, C5, C6, C13, C14, C15, C29.	CAPACITOR, fixed: ceramic dielectric; 1500 $\mu\mu\text{f}$ $+20\%$ -10% ; 500 vdcw; Electrical Reactance Corp type #CFC-1.	C1, C2, C3: Measurement circuit bypass (r-f). C5, C6: Carry oscillator plate bypass (r-f). C13, C14, C15: Carry oscillator filament bypass (r-f). C29: Crystal (V9) circuit r-f bypass.	3DA1.500-52.
C4, C16-----	CAPACITOR, fixed: mica dielectric; 2400 $\mu\mu\text{f}$ $\pm 5\%$; 1250 vdcw; Davenco part #6005A.	C4: Measurement circuit bypass (r-f). C16: Carries oscillator filament bypass (r-f).	3D9240-29.
C33-----	CAPACITOR, fixed: mica dielectric; 10,000 $\mu\mu\text{f}$ $\pm 10\%$; 300 vdcw; JAN type CM35B103K.	Coupling from PERCENT MOD. control to grid of V7.	3K3510321.
C31, C32-----	CAPACITOR, fixed: ceramic dielectric; 10,000 $\mu\mu\text{f}$, -0 $+20\%$; 500 vdcw; Electrical Reactance Corp type #BPD-.01.	Carry oscillator filament bypass---	3DA10-539.
C23, C25, C26-----	CAPACITOR, fixed: paper dielectric; 100,000 $\mu\mu\text{f}$ $\pm 20\%$; 600 vdcw.	C23: Coupling from plate of tube V7 to grid of tube V1. C25: Coupling from EXT. MOD. jack to switch S2. C26: Coupling from grid of tube V2 to plate of tube V8.	3DA100-853.
C22, C27, C34-----	CAPACITOR, fixed: paper dielectric; 250,000 $\mu\mu\text{f}$ $\pm 20\%$; 600 vdcw.	C22: Screen-grid bypass, tube V7. C27: Coupling from tube V2 to diode-connected section of tube V8. C34: Coupling from plate of tube V1 to grid and cathode of tube V7.	3DA250-445.
C28-----	CAPACITOR, fixed: electrolytic; 2 sect.; 10-10 μf ; 450 vdcw; JAN type CE42F100R.	Power supply filter-----	3DB10-168.
C12-----	CAPACITOR ASSEMBLY: c/o 2 ea variable capacitors, 5-55 $\mu\mu\text{f}$, 1 ea fixed capacitor 62 $\mu\mu\text{f}$; RCC part No. CN800240.	Carries frequency tuning-----	3DE62V.
	CLAMP, electrical: for T-11, T-12, and ST-12 envelopes; MT-10 metal envelope; Times Facsimile part No. 3 top hat retainer and part No. 32 post.	For securing tube V4 and V6-----	2Z2642.485.
L6A-----	COIL, RF: unshielded; 123 μh , 2-5 mc; Davenco part #6540.	Oscillator tuning A band-----	3C1081-51A.
L6B-----	COIL, RF: unshielded; 21.5 μh , 5-13 mc; Davenco part #6541; includes R9B, a 1,000-ohm resistor.	Oscillator tuning B band-----	3C1081-51B.
L6C-----	COIL, RF: unshielded; 3.3 μh , 13-30 mc; Davenco part #6542; includes R9C, a 1,000-ohm resistor.	Oscillator tuning C band-----	3C1084Z84.

2. Identification Table of Parts for Signal Generator TS-497B/URR—Continued

Ref. symbol	Name of part and description	Function of part	Signal Corps stock No.
L6D	COIL, RF: unshielded; 0.55 μ h, 30–78 mc; Davenco part #6543; includes R9D, a 1,000-ohm resistor.	Oscillator tuning D band	3C1084Z84-1.
L6E	COIL, RF: unshielded; 0.077 μ h, 78–180 mc; Davenco part #6544; includes R9E, a 1,000-ohm resistor.	Oscillator tuning E band	3C1084Z84-2.
L6F	COIL, RF: unshielded; 0.018 μ h, 180–400 mc; Davenco part #6545; includes R9F, a 4,700-ohm resistor.	Oscillator tuning F band	3C1084Z84-3.
L9	COIL, RF: choke; unshielded; 13 μ h at 1,000 cyc, 0.5 amp; Davenco part #6034.	Oscillator filament choke	3C319G-1.
L3, L4, L5, L13, L14, L15.	COIL, RF: choke; unshielded; 20 μ h at 1,000 cyc 50 ma; 1.6 ohms d-c resistance; Davenco part #6025.	L3, L4, L5: R-f filters, oscillator plate circuit. L13, L14, L15: R-f filters, measurement circuit.	3C319G-2.
L2	COIL, RF: choke; unshielded; 42 μ h at 1,000 cyc, 50 ma; 3.4 ohms d-c resistance; Davenco part #6026.	R-f filter, oscillator plate circuit	3C319G-3.
L7, L8	COIL, RF: choke; shielded, cylindrical paper cen; Fast part #P-32212.	Oscillator filament chokes	3C319G-4.
L1, L12	COIL, RF: choke; unshielded; 1 mh at 1,000 cyc, 50 ma; 23 ohms d-c resistance; Davenco part #6024.	L1: R-f filter, oscillator plate circuit. L12: R-f filter, measurement circuit.	3C319G.
	CONNECTOR, plug: Radio Frequency Plug UG-21B/U; 1 round male coax cont; straight type.	Terminations for Cord CG-55B/U	2Z7390-21B.
	CONNECTOR, plug: Plug Connector UG-536/U; 1 round male cont; straight type.	Termination for RF Cable Assembly CG-683/U.	2Z7390-536.
	CONNECTOR, plug: 2 parallel blades male cont; straight type; Hubbell type 7057.	Power connector	6Z1727.
J2	CONNECTOR, receptacle: Radio Frequency receptacle UG-58A/U; 1 round female cont; straight type.	PULSE INPUT jack	2Z7390-58A.
J3	CONNECTOR, receptacle: 1 round female cont; straight; Industrial Products Co. part #36000.	CARRIER OUTPUT jack	2Z3062-235.
	COVER, panel: protective; Davenco part #6282.	Protects instruments on front panel.	2Z3351-295.
V9, V10	CRYSTAL, rectifier: JAN type 1N21B	V9: Measurement circuit detector. V10: Provides temperature compensation.	2J1N21B.
	DIAL CONTROL: scale marking 0 thru 100; Davenco part #6547A.	Tuning dial	2Z3723-318.
	DIAL CONTROL: Davenco part #6535A.	MICROVOLTS dial	2Z3723-317.
F1	FUSE FU-26: 1 amp	Overload protection	3Z1926.
E2, E3	FUSEHOLDER: extractor post; for single AGC-1 fuse; BUSS type #HKP.	E2: Holder for operating fuse. E3: Holder for spare fuse.	3Z3285-6.7.
J1	JACK JK-34-A: for 2 cond plug 0.25" dia; JAN type JJ-034.	EXT. MOD. jack	2Z5534.
	JUNCTION BOX: 0.195" o/a dia of cable; Davenco part #6250; Davenco dwg #A3015-25 (issue C).	Termination for RF Cable Assembly CG-683/U.	6Z6512-3.

2. Identification Table of Parts for Signal Generator TS-497B/URR—Continued

Ref. symbol	Name of part and description	Function of part	Signal Corps stock No.
	KNOB: hex., w/pointer; black bakelite; ¼" dia shaft; white line on pointer; Davenco part #6230A.	Used as the EXT. PULSE knob, the PERCENT MOD. knob, and the modulator selector knob.	2Z5821-171.
	KNOB: bar; blk Alumilite finish on aluminum; 0.391" dia shaft; Davenco part #6229A.	Range knob	2Z5821-170.
E1	LAMP LM-27: 6-8 v, 0.25 amp; miniature bayonet base.	Illumination of frequency dial	2Z5927.
E4	LAMP, incandescent: 120 v, 3 w; candelabra screw base; GE #S-6.	Ballast lamp, provides degeneration for audio oscillator V7.	6Z6820-3.
J4	LAMPHOLDER: candelabra; Dialco part #611.	Socket for lamp E4	2Z5884-96.
J5	LAMPHOLDER: miniature bayonet; Drake Mfg #706-C.	Socket for dial lamp E1	2Z5883-348.
	POST, binding: screw type; Davenco part #6467.	For holding test leads	3Z741-38.1.
L11	REACTOR: single sect.; 8 hy min at 10 v, 0.085 amp d-c; 175 ohms d-c resistance; HS metal case; Chi Trans cat. #RH-1085.	Power supply filter choke	3C547-40.
L10	REACTOR: modulation; single sect.; 12 hy min at 10 v, 0.040 amp d-c; 475 ohms d-c resistance; HS metal case; Chi Trans cat. #RH-1540.	Plate load for tube V2	3C547-39.
R12	RESISTOR, fixed: comp; 47 ohms ± 10%; ½ w; JAN type RC20BF470K.	Carries oscillator plate filter	3RC20BF470K.
	RESISTOR, fixed: comp; 52.5 ohms ± 3%; ½ w; AB type #EB525G3.	Terminating resistor across binding posts of RF Cable Assembly CG-683/U.	3Z6005-B2-3.
R7	RESISTOR, fixed: comp; 100 ohms ± 10%; ½ w.	Measuring circuit resistor	3RC20BF101K.
R11	RESISTOR, fixed: comp; 160 ohms ± 5%; ½ w; JAN type RC20BF161J.	Carrier oscillator cathode resistor	3RC20BF161J.
R14	RESISTOR, fixed: comp; 680 ohms ± 10%; ½ w; JAN type RC20BF681K.	Carrier oscillator plate	3RC20BF681K.
R13, R30, R38	RESISTOR, fixed: comp; 1,000 ohms ± 10%; ½ w; JAN type RC20BF102K.	R13: Pulse modulation input filter. R30: Cathode bias V1. R38: Cathode bias V2.	3RC20BF102K.
R34	RESISTOR, fixed: comp; 2,700 ohms ± 10%; ½ w; JAN type RC20BF272K.	Bias voltage divider V8	3RC20BF272K.
R31	RESISTOR, fixed: film; 3,000 ohms ± 2%; 1 w; Concarbon type NOBELOY X-1.	Audio oscillator degeneration	3Z6300-227.
R44	RESISTOR, fixed: WW; 1,000 ohms ± 5%; 12 w; JAN type RW32G102.	Current limiting V4 and V6	3RW27907.
R35	RESISTOR, fixed: comp; 10,000 ohms ± 10%; 1 w; JAN type RC30BF103K.	Bias voltage divider V8	3RC30BF103K.
R8, R28	RESISTOR, fixed: comp; 20,000 ohms ± 5%; 2 w; JAN type RC12BE203J.	Plate load V1	3RC12BE203J.
R10	RESISTOR, fixed: comp; 22,000 ohms ± 10%; 2 w; JAN type RC20BF 223K.	Carrier oscillator grid return	3RC20BF223K.
R27, R29, R37	RESISTOR, fixed: comp; 47,000 ohms ± 10%; ½ w; JAN type RC20BF474K.	R27: Screen voltage dropping V7. R29: Grid return V1. R37: Grid return V2.	3RC20BF474K.
R36	RESISTOR, fixed: comp; 100,000 ohms ± 10%; ½ w; JAN type RC20BF104K.	Modulation amplifier degeneration.	3RC20BF104K.
R4, R32, R45	RESISTOR, fixed: comp; 100,000 ohms ± 10%; ½ w; JAN type RC20BF104K.	R4: Metering circuit resistor. R32: Plate load V8. R45: Plate load V7.	3RC20BF104K.

2. Identification Table of Parts for Signal Generator TS-497B/URR—Continued

Ref. symbol	Name of part and description	Function of part	Signal Corps stock No.
R46	RESISTOR, fixed: comp; 1 meg $\pm 10\%$; $\frac{1}{2}$ w; JAN type RC20BF105K.	Grid return V8 (amplifier section).	3RC20BF105K.
R40	RESISTOR, fixed: film; 27,000 ohms $\pm 2\%$; 1 w; Concarbon type NOBELOY X-1.	Input voltage divider V8 (metering section).	3Z6627-40.
R39	RESISTOR, fixed: film; 50,000 ohms $\pm 2\%$; 1 w; Concarbon type NOBELOY X-1.	Input voltage divider V8 (metering section).	3Z6650-174.
R42	RESISTOR, fixed: film; 100,000 ohms $\pm 2\%$; 1 w; Concarbon type NOBELOY X-1.	Bias voltage divider V8 (metering section).	3Z6700-212.
R25, R26	RESISTOR, fixed: film; 265,000 ohms $\pm 2\%$; 1w; Concarbon type NOBELOY X-1.	Audio oscillator frequency determination (1,000 cycle).	3Z6726E5.
R23, R24	RESISTOR, fixed: film; 400,000 ohms $\pm 2\%$; 1 w; Concarbon type NOBELOY X-1.	Audio oscillator frequency determination (400 cycle).	3Z6740-15.
R43	RESISTOR, variable: WW; 200 ohms $\pm 10\%$; 3 w; JAN type.	Zero adjustment for PERCENT MODULATION meter.	3RA4206.
R5	RESISTOR, variable: WW; 500 ohms $\pm 10\%$; 3 w; JAN type RA25A1SA501AK.	Adjusts d-c bias or crystals.	3RA5104.
R41	RESISTOR, variable: WW; 10,000 ohms $\pm 10\%$; 3 w; JAN type RA25A1SA103AK.	Calibration adjustment for PERCENT MODULATION meter.	3RA7504.
R33	RESISTOR, variable: comp; 100,000 ohms $\pm 20\%$ 2.25 w.	PERCENT MOD. control.	3Z7480-175.
R47	RESISTOR, fixed: comp; 150,000 ohms $\pm 10\%$; RC20BF154K.	Current limiting resistor for V4.	3RC20BF154K.
	SHIELD, electron tube: bayonet type mtg; JAN type TSFOT103.	Tube shield.	2Z8304.172.
	SHIELD, electron tube: bayonet type mtg; JAN type TSFOT102.	Tube shield.	2Z8304.154.
	SHIELD, electron tube: bayonet type mtg; JAN type TSFOT105.	Tube shield.	2Z8304.183.
X1, X2, X7	SOCKET, electron tube: 7 cont miniature; 1 piece saddle mtg; JAN type TSE7T101.	Sockets for V1, V2, and V7.	2Z8677.94.
X4, X5, X6	SOCKET, electron tube: 8 cont med octal; 1 piece saddle mtg; JAN type TSB8T102.	Sockets for V4, V4, and V6.	2Z8678.327.
X8	SOCKET, electron tube: 9 cont; 1 piece saddle mtg; JAN type TSE9T101.	Socket for V8.	2Z8679.30.
S3	SWITCH, rotary: SPDT; single deck; Davenco part #6087.	EXT. PULSE switch.	3Z9825-58.193.
S2	SWITCH, rotary: 3-pole, 4-position; single deck; Davenco part #6086.	Modulation selector.	3Z9825-57.3.
S1	SWITCH, toggle: SPST; JAN type ST12A.	POWER-ON-OFF switch.	3Z9863-12A.
T1	TRANSFORMER, power: step-down, fil type; 117 v, 60 cyc, 1-ph; secd No. 1—6.3 v CT, 3 amp, secd No. 2—5 v, 2 amp, secd No. 3—320-0-320 v, .07 amp; HS metal case; Chi Trans cat #PHC-70.	Power transformer.	2Z9617-258.
V5	TUBE, electron: type 5Y3GT.	Rectifier.	2J5Y3GT.
V1, V2	TUBE, electron: type 6AQ5.	V1: Audio oscillator V2: Modulator.	2J6ZQ5.
V7	TUBE, electron: type 6AU6.	Audio oscillator.	2J6AU6.

2. Identification Table of Parts for Signal Generator TS-497B/URR—Continued

Ref. symbol	Name of part and description	Function of part	Signal Corps stock No.
V8	TUBE, electron: type 12AU7	Modulation amplifier	2J12AU7.
V11	TUBE, electron: type 955	Carrier oscillator	2J955.
V4	TUBE, electron: type OA3	Voltage regulator	2JOA3.
V6	TUBE, electron: type OC3	Voltage regulator	2JOC3.
	WRENCH TL-567/U: Allen type hex. key, short arm series; $\frac{1}{16}$ " across flats; fits No. 5 or No. 6 screws.	For removing Allen-head screws	6R57400-6.
	WRENCH, socket head screw: Allen type L-shaped; $\frac{5}{64}$ " across flats; spcl for Allen type No. 8 socket head set-screw and Allen Mfg No. 4 socket head cap screw.	For removing Allen-head screws	6R57400.
	WRENCH, socket head screw: Allen type hex., L-shaped; $\frac{3}{32}$ " across flats.	For removing Allen-head screws	6R55496.
	WRENCH, socket head screw: Allen type hex., L-shaped; 0.050" across flats.	For removing Allen-head screws	6R55499.

CAPACITOR COLOR AND LETTER CODES

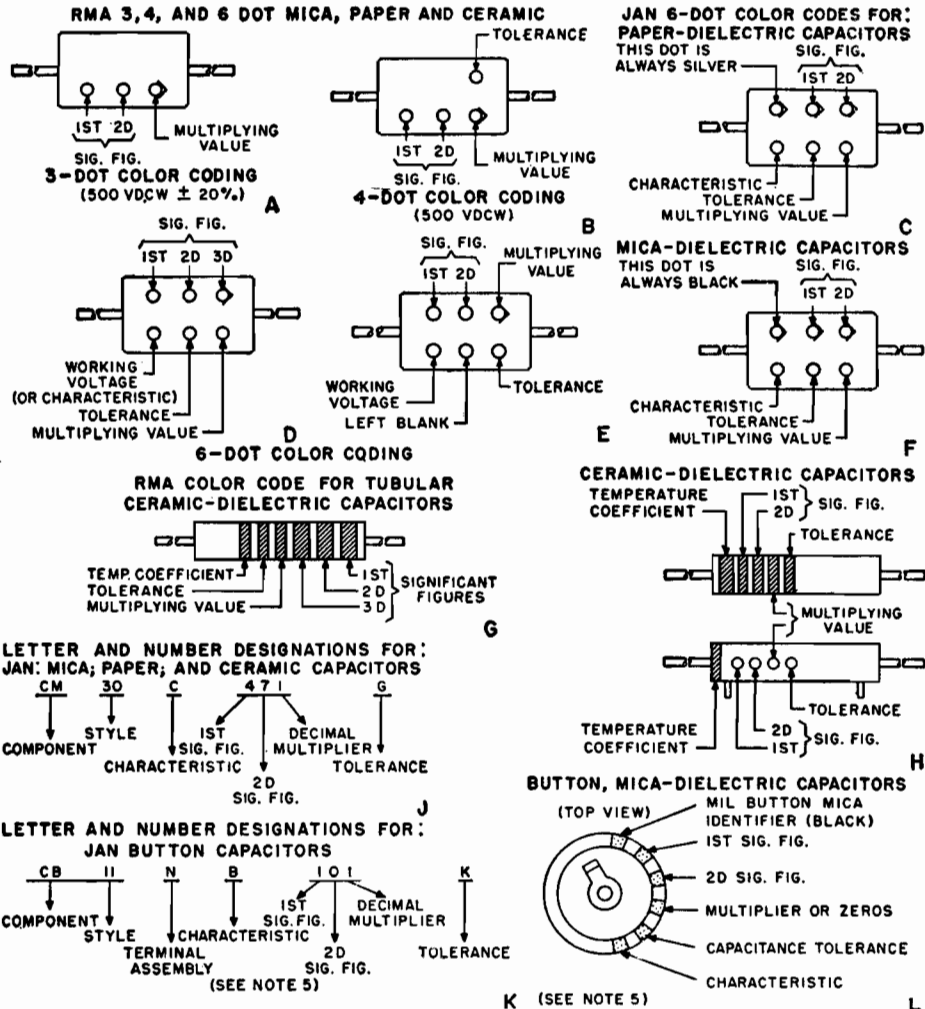

- STANDARDS -					JAN MICA-CM		JAN PAPER-CN		JAN CERAMIC-CC					
COLOR	SIG. FIG.	DECIMAL MULTIPLIER	% TOL.	VDCW	LETTER TOL.	CHARAC-TERISTIC	LETTER TOL.	CHARAC-TERISTIC	DEC. MULT.	%	LETTER DESIGNIGATION	UUF	LETTER DESIGNIGATION	CHARAC-TERISTIC
BLACK	0	1	±20	500	M	A	M	A	1	±20	M	±2.0	G	C
BROWN	1	10	±1	100	-	B	-	E	10	±1	F	-	-	H
RED	.2	100	±2	200	G	C	-	H	100	±2	G	-	-	L
ORANGE	3	1,000	±3	300	-	D	N*	J	1,000	-	-	-	-	P
YELLOW	4	10,000	±4	400	-	E	-	P	-	-	-	-	-	R
GREEN	5	100,000	±5	500	-	F	-	R	-	±5	J	±0.5	D	S
BLUE	6	1,000,000	±6	600	-	G	-	S	-	-	-	-	-	T
VIOLET	7	10,000,000	±7	700	-	-	-	T	-	-	-	-	-	U
GRAY	8	100,000,000	±8	800	-	-	-	-	0.01	-	-	±0.25	C	B
WHITE	9	1,000,000,000	±9	900	-	-	-	-	0.1	±10	K	±1.0	F	SL
GOLD	-	0.1	±5	1,000	J	-	-	-	-	-	-	-	-	A
SILVER	-	0.01	±10	2,000	K	-	-	-	-	-	-	-	-	-
NO COLOR	-	-	±20	500	-	-	-	-	-	-	-	-	-	-

* THE TOLERANCE OF THIS CAPACITOR IS ±30%, NOT ±25%

NOTES

- JAN: JOINT ARMY-NAVY
- RMA: RADIO MANUFACTURERS ASSOCIATION
- 1. THESE COLOR AND LETTER CODES GIVE CAPACITANCES IN MICROMICROFARADS
- 2. THIS TABLE IS ADAPTED FOR JAN AND RMA COLOR AND JAN LETTER TYPE DESIGNATIONS
- 3. CERAMIC AND MICA CAPACITORS, BOTH JAN AND RMA, ARE GENERALLY 500 VDCW
- 4. BUTTON CAPACITORS ARE GENERALLY 300 VDCW
- 5. READ BUTTON CAPACITOR TOLERANCE UNDER CERAMICS OF MORE THAN 10 UUF
- 6. CHARACTERISTICS ARE AVAILABLE IN JAN CAPACITOR SPECIFICATION MANUALS
- 7. THE COMPONENTS USED ABOVE FOR JAN LETTER TYPE DESIGNATIONS ARE:
 CP MICA BUTTON; CC CERAMIC; CM MICA MOULDED; CN PAPER MOULDED

TM CC

Figure 23. Capacitor color codes.

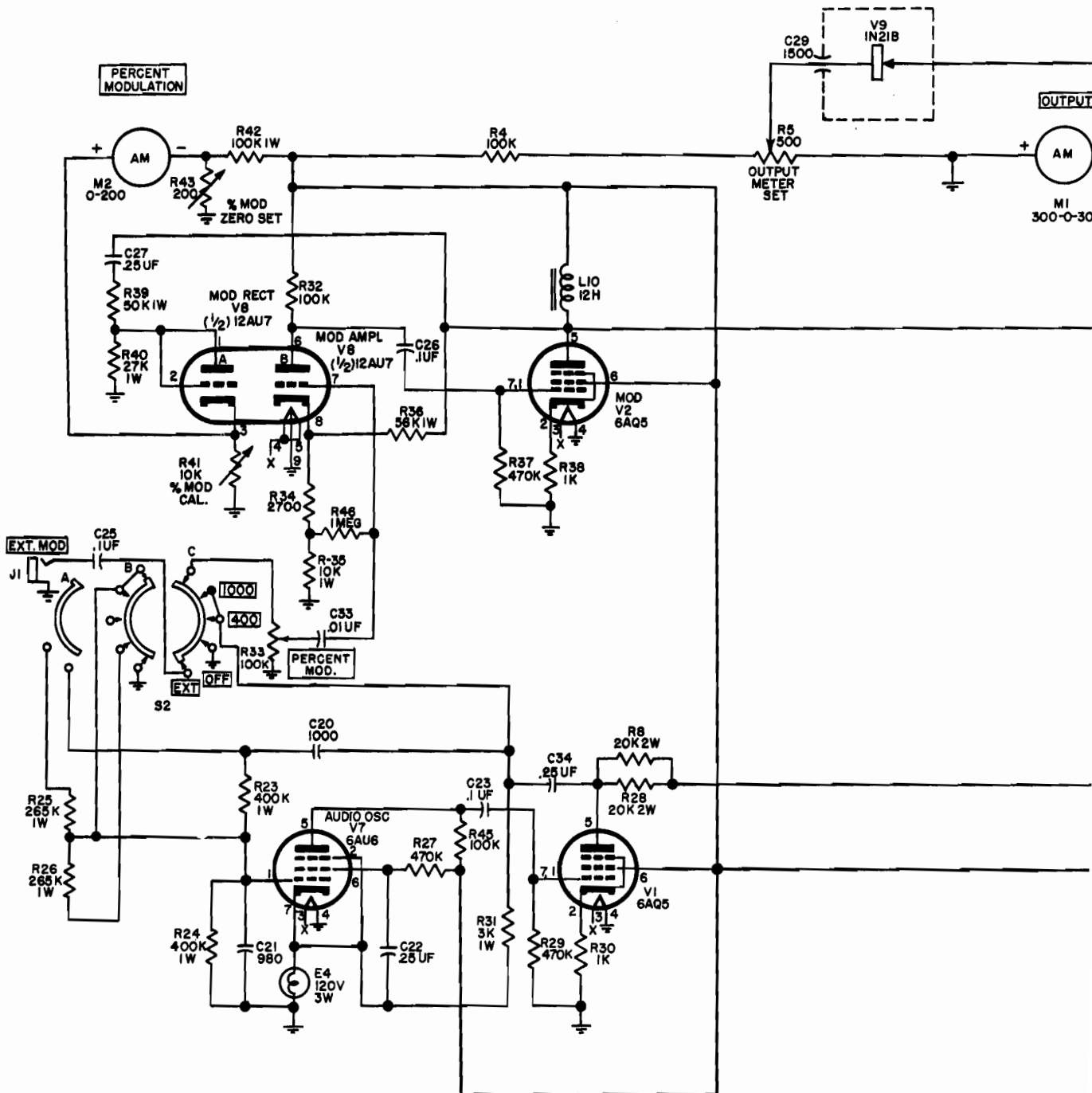

374603 O - 53 (Face P. 56)

NOTE:
 1. RESISTOR
 OTHERWISE
 2. CAPACITY
 3. * L6A, B,
 R9B, C,
 R9 B, C
 NO RE

FIGURE 24.—Signal Generator TS-46

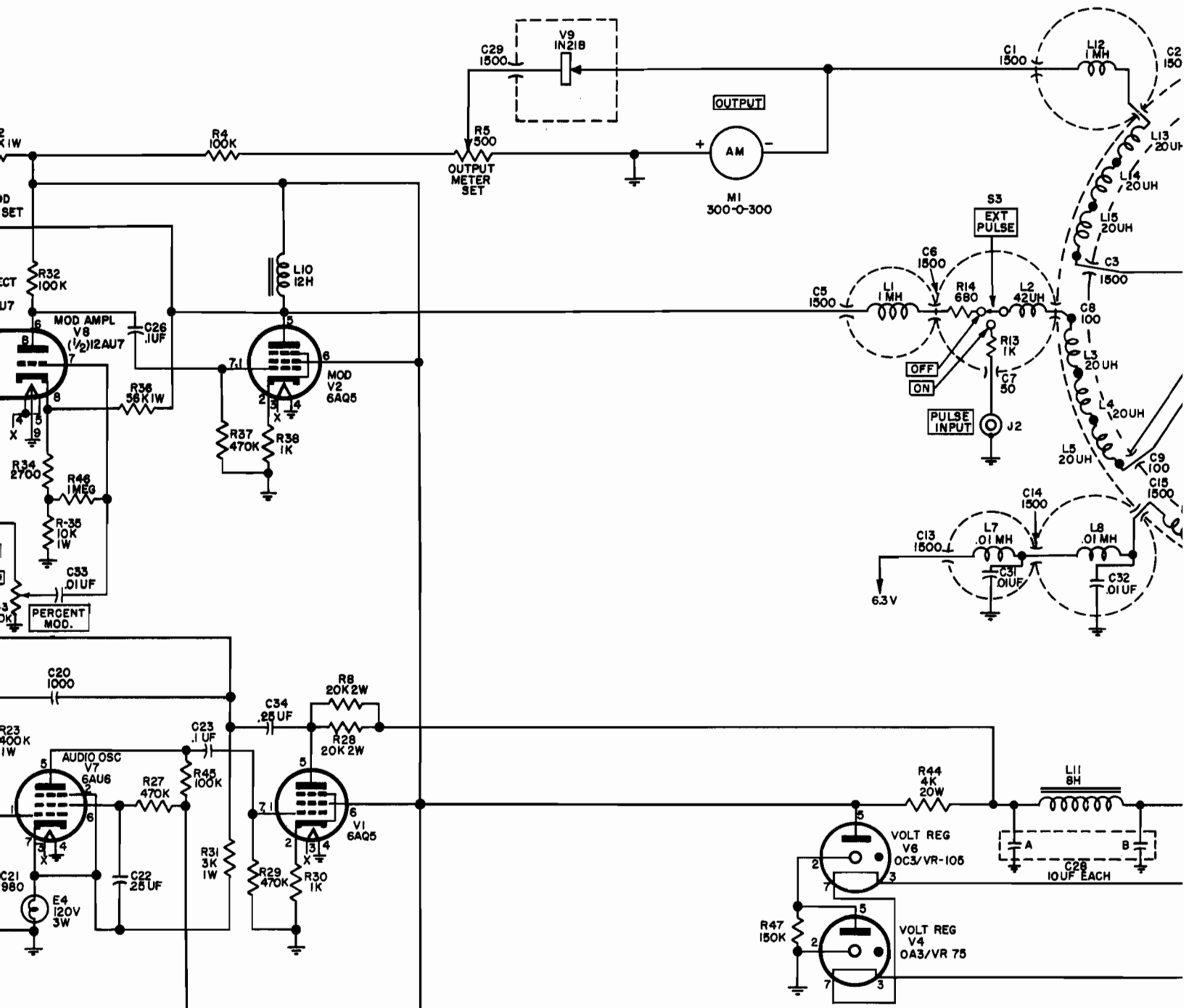

NOTE:

1. RESISTORS ARE IN OHMS AND ARE 1/2 WATT UNLESS OTHERWISE SPECIFIED.
2. CAPACITORS IN UUF UNLESS OTHERWISE SPECIFIED.
3. * L6A, B, C, D, E OR F IS SELECTED BY THE RANGE KNOB. R9B, C, D, E OR F IS SELECTED BY THE RANGE KNOB. R9B, C, D OR E IS 1,000 OHMS, R9F IS 4,700 OHMS. NO RESISTOR IS USED ON BAND A.

4. SWITCH S2 IS VIEWED WITH
5. SWITCH S-2

FIGURE 24.—Signal Generator TS-497B/URR, overall schematic.

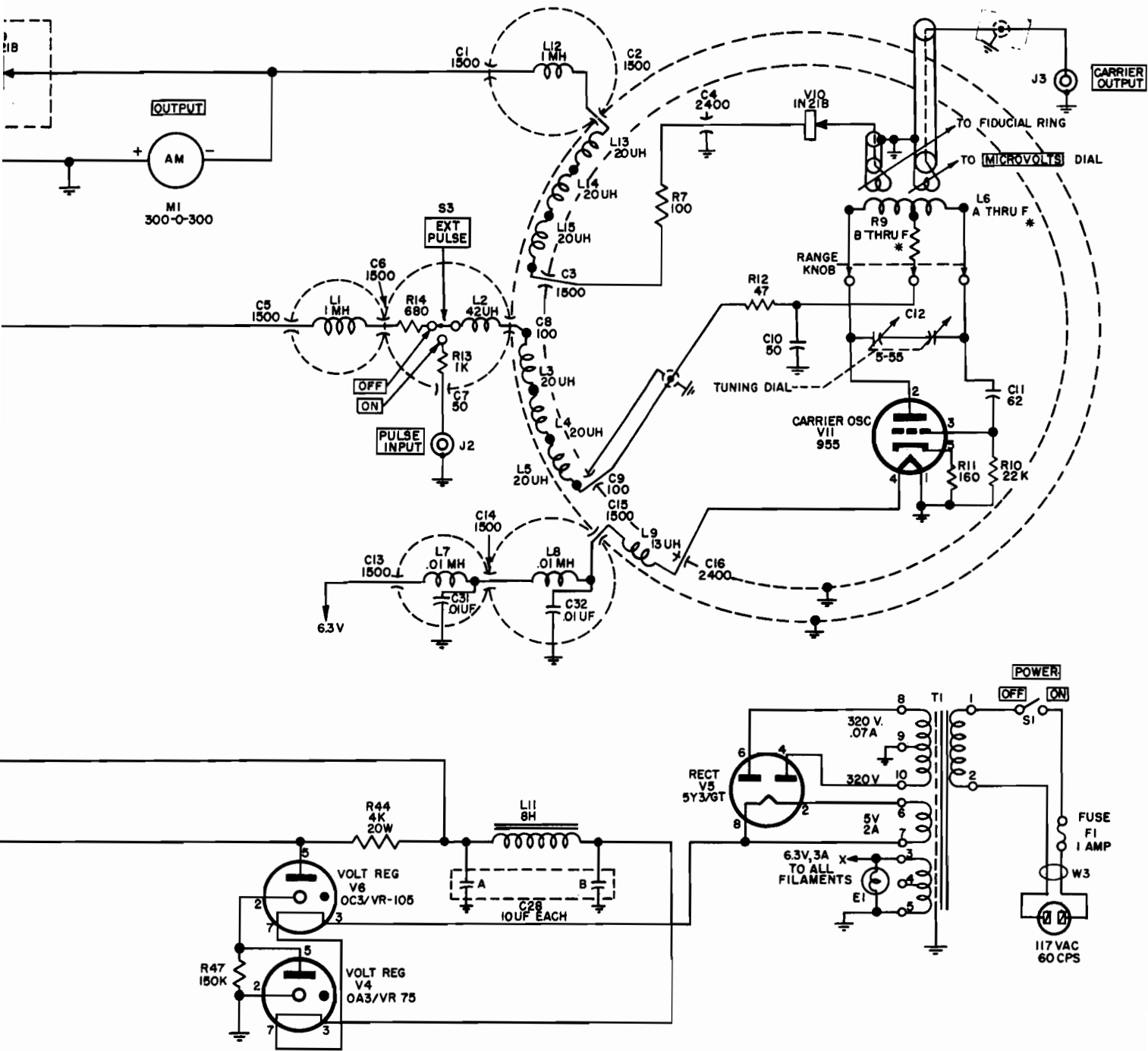

NOTE:

1. RESISTORS ARE IN OHMS AND ARE $\frac{1}{2}$ WATT UNLESS OTHERWISE SPECIFIED.
2. CAPACITORS IN UUF UNLESS OTHERWISE SPECIFIED.
3. * L6A, B, C, D, E OR F IS SELECTED BY THE RANGE KNOB. R9B, C, D, E OR F IS SELECTED BY THE RANGE KNOB. R9B, C, D OR E IS 1,000 OHMS, R9F IS 4,700 OHMS. NO RESISTOR IS USED ON BAND A.
4. SWITCH S2 IS SINGLE SECTION SWITCH, 3 POLE, 4 POSITION, VIEWED WITH CHASSIS INVERTED AND FROM END OPPOSITE CONTROL KNOB.
5. SWITCH S-2 "A" IS ON REAR OF SECTION, "B" IS ON FRONT OF SECTION L.H. SIDE "C" IS ON FRONT OF SECTION R.H. SIDE

-Signal Generator TS-497B/URR, overall schematic.

TM 5030A-19

826-361-6