



DOCUMENT NUMBER: 17-00175
 ISSUE NUMBER: 2
 ISSUE DATE: February, '98

RELATED DOCUMENTS:
 C/R 25243
 17-00180

9323/9360/9390/9680/9780 lock up

1. Scope

9323/9360/9390/9780 transceivers in mobile installations are prone to lock up problems if the radio is on during engine cranking.

2. Symptom

Two symptoms have been identified:

- the display on the front panel/control head is blanked although the radio continues to function normally
- the radio fails to respond to any button presses although the display remains

3. Corrective action

Circuit modifications have occurred to overcome this problem. The following table identifies the first transceivers fitted with the modified circuits. Section 4 details the steps required to retrospectively fit the revised circuits.

Transceiver type	Serial Number
9323	E0652
9323-H	E0110
9360	E1426
9360-C	E0100
9360-V	A0269
9390	E0274
9680	E0300
9780	B0556

Head Office

Codan Pty Ltd
 ACN 007 590 605
 81 Graves Street
 Newton
 South Australia 5074
 Telephone +61 8 8305 0311
 Facsimile +61 8 8305 0411

Email:
radcom@codan.com.au
Worldwide Web:
<http://www.codan.com.au>

Codan (UK) Ltd
 Gostrey House
 Union Road
 Farnham, Surrey GU9 7PT
 United Kingdom
 Telephone +44 1252 717 272
 Facsimile +44 1252 717 337
 Telex 858355

Codan Pty Ltd
 Suite 11A, 2 Hardy Street
 South Perth
 Western Australia 6151
 Telephone +61 8 9368 5282
 Facsimile +61 8 9368 5283

4. Modification

The modification is in two parts. Part one describes the steps required to modify the microprocessor reset circuit in the transceiver. Part two addresses the front panel and control head circuits.

Parts required

1 x XD-01233-500 reset IC (Integrated Circuit) and 1 x 47 k Ω CR25, 0.33 watt resistor (Codan part number 40-44700-020) shall be required for each of the following (minimum of two):

- the main transceiver
- at each control point (front panel or control head)

Tools required

- Pozidrive screwdriver (1 point)
- Desoldering tool
- 60/40 Tin/Lead resin core solder
- Soldering iron
- Side cutters
- Scalpel or sharp blade

The following tools may also be useful:

- Tweezers or small nose pliers
- Surface Mount Device (SMD) desoldering tool

4.1 Part one

This procedure describes the modification to the **transceiver**. The procedure covers two possible circuit configurations.

Procedure

- Remove the transceiver (including the control head where applicable) from the installation.
- Remove the two screws securing the bottom cover and remove the cover.
- Locate the Microprocessor and Audio Assembly PCB (Printed Circuit Board), 08-04966-001.
- Disconnect all the ribbon cables from the PCB taking careful note of the orientation of the connectors on P103 and P302.
- Remove the eight screws securing the PCB.
- Withdraw the PCB from the chassis.
- Locate and remove R124, R125, R126, and C114. Refer to Figures 1 and 2.

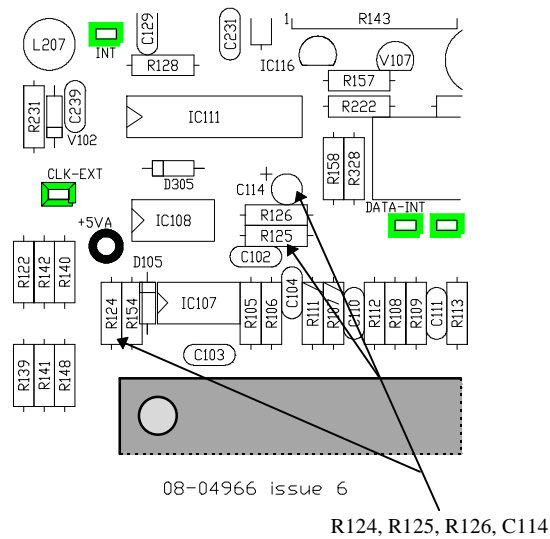

Figure 1: Location of components

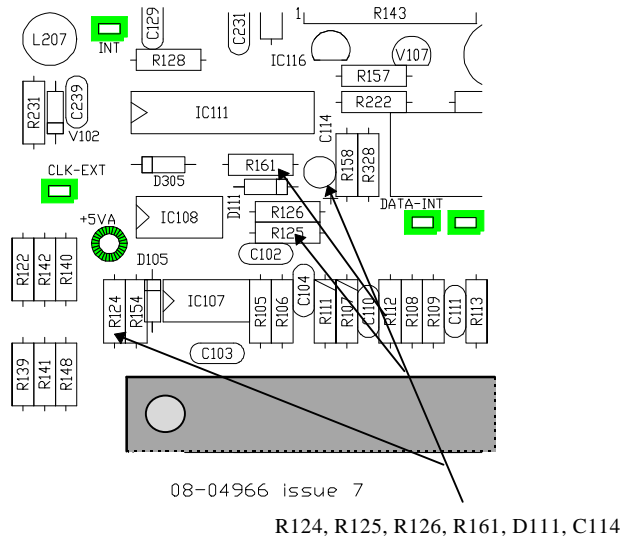

Figure 2: Location of components

- Remove R161 and D111 if fitted. Refer to Figures 1 and 2.
- Locate IC107 (LM358). Refer to Figure 3.

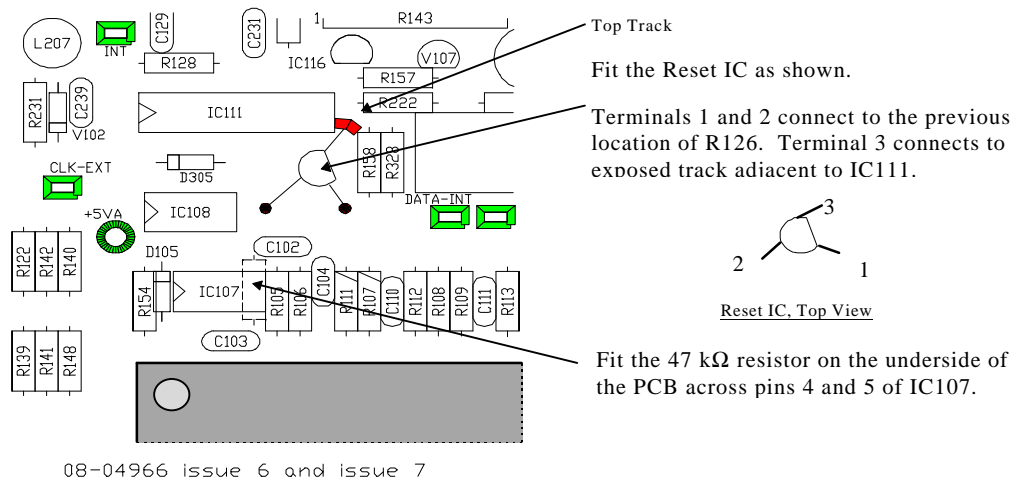

Figure 3: Location of IC and 47 kΩ resistor

- Fit and solder the 47 kΩ resistor across pins 4 and 5 of IC107. This is best done on the underside. Refer to Figure 3.
- Locate the track on the component side of the PCB adjacent to IC111. Refer to Figure 3.
- Using the scalpel or blade, carefully scrape the green masking from the track so that approximately 2 mm of bare copper is exposed.
- Tin the exposed copper.
- Fit the Reset IC as shown in Figure 3.
- Fit and secure the PCB into the chassis with the eight screws.
- Replace all ribbon cables onto their corresponding connectors paying particular attention to the orientation of P103 and P302.

4.2 Part two

This procedure describes the modification to the **front panel** and/or **control head**. The procedure covers two possible circuit configurations.

Refer to Service Bulletin 17-00180 as further work may be required.

- If you want to modify a front panel, continue at *Procedure: front panel*.
Otherwise, continue at *Procedure: control head*.

Procedure: front panel

- Disconnect the cable connecting the front panel to the Microprocessor and Audio PCB.
- Remove the four screws securing the front panel to the chassis.
- Withdraw the entire front panel from the chassis.
- Remove the two screws securing the shield covering the front panel PCB.
- Remove the shield.
- Continue at *Procedure: modification*.

Procedure: control head

- Remove the two screws securing the back panel and remove the panel.
- Carefully disconnect the control interface cable (P4) and the extension speaker plug (if fitted).

Procedure: modification

- Locate R8, R10, R11, and C4. Refer to Figures 4 and 5.

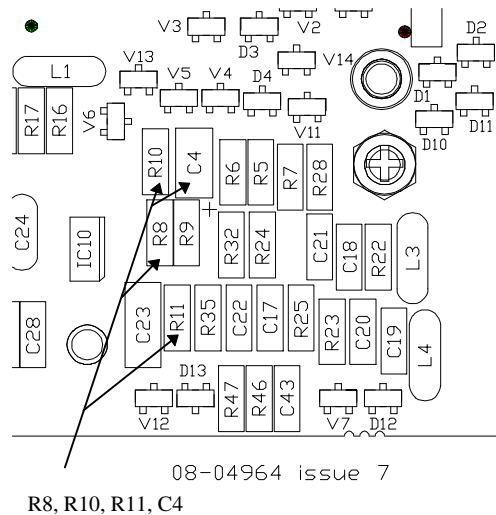
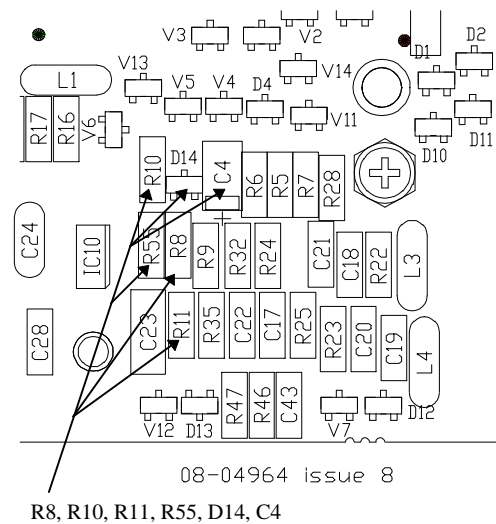
**Figure 4: Location of components****Figure 5: Location of components**

- Using a pair of tweezers (or small nose pliers) and soldering iron, or a SMD desoldering tool, remove R8, R10, R11, and C4 from the PCB.
- Remove R55 and D14 if fitted. Refer to Figures 4 and 5.
- Fit and solder the 47 kΩ resistor as shown in Figure 6 or 7.

Fit 47 kΩ resistor between R8 and R10 pads as shown

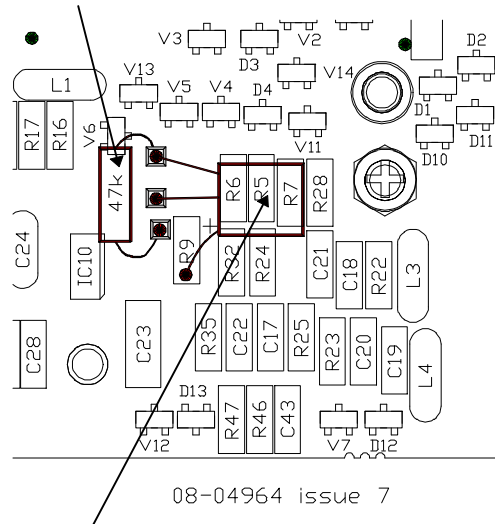

Fit Reset IC to, R10 pads and to R9—**Flat side UP**

Figure 6: Location of IC and 47 kΩ resistor

Fit 47 kΩ resistor between R8 and R10 pads as shown

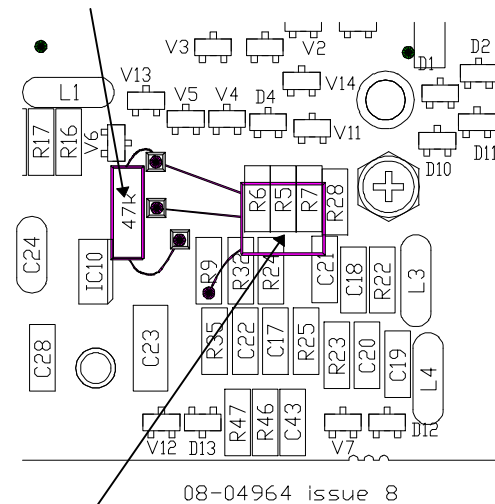

Fit Reset IC to, R10 pads and to R9—**Flat side UP**

Figure 7: Location of IC and 47 kΩ resistor

- Fit and solder the Reset IC as shown in Figure 6 or 7.

Reassembly

- Reassembly of the front panel is the reverse of the steps in *Procedure: front panel*.
- Reassembly of the control head is the reverse of the steps in *Procedure: control head*.
- Refit the bottom cover to the transceiver and secure with the two screws.
- Reinstall the transceiver (including the control head where applicable) to the installation.