

DO NOT SCALE

ITEM	PART No.	DESCRIPTION
1	15-10412-001	FITTING INSTRUCTIONS
2	08-05090-001	MICROPROCESSOR PCB
3	08-05091-001	LOOM, OPT RS
4	90-20540	EPROM
5	30-05102-001	CABLE CLAMP
6	15-10271	OPTION PS

NOTES:

1. REMOVE BOTTOM COVER.
2. FIT OPTION PS COMPONENTS TO MOTHERBOARD. DO NOT FIT PS LOOM.
3. REMOVE MICROPROCESSOR PCB AND REPLACE WITH ITEM 2.
4. CHECK ISSUE NO OF EPROM - ITEM 4. IT IS TO BE AT LEAST 4-4.
5. INSTALL LOOM - ITEM 3 AND ATTACH WITH ITEM 5 AS SHOWN.
6. TEST FOR CORRECT OPERATION.
7. REPLACE BOTTOM COVER.

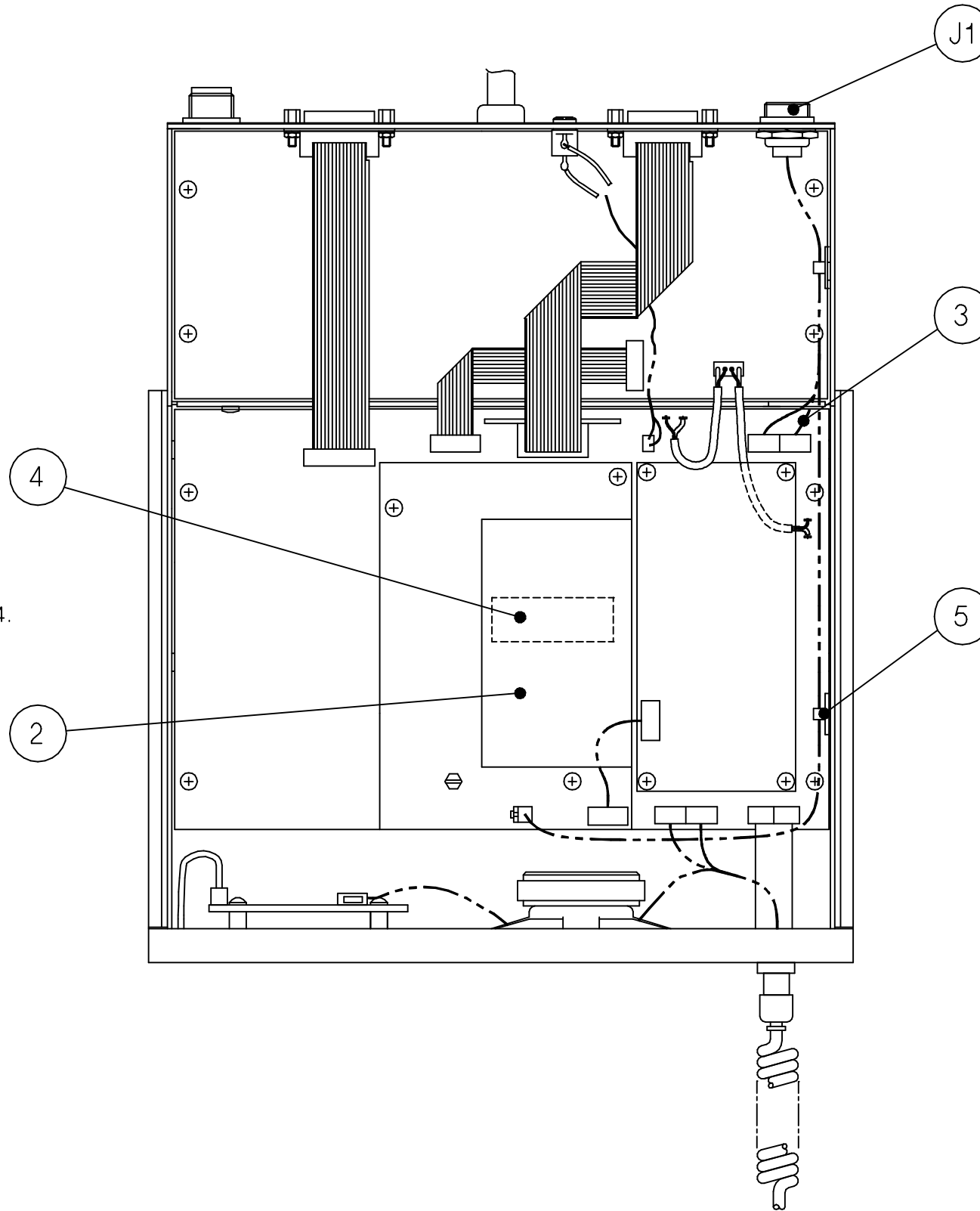

ISSUE B
OPTION RS ADDED.
C/R 23929
7-4-94 NJA

ISSUE C
ITEM 4 WAS 90-20278
C/R 23930
30-5-94 CAH

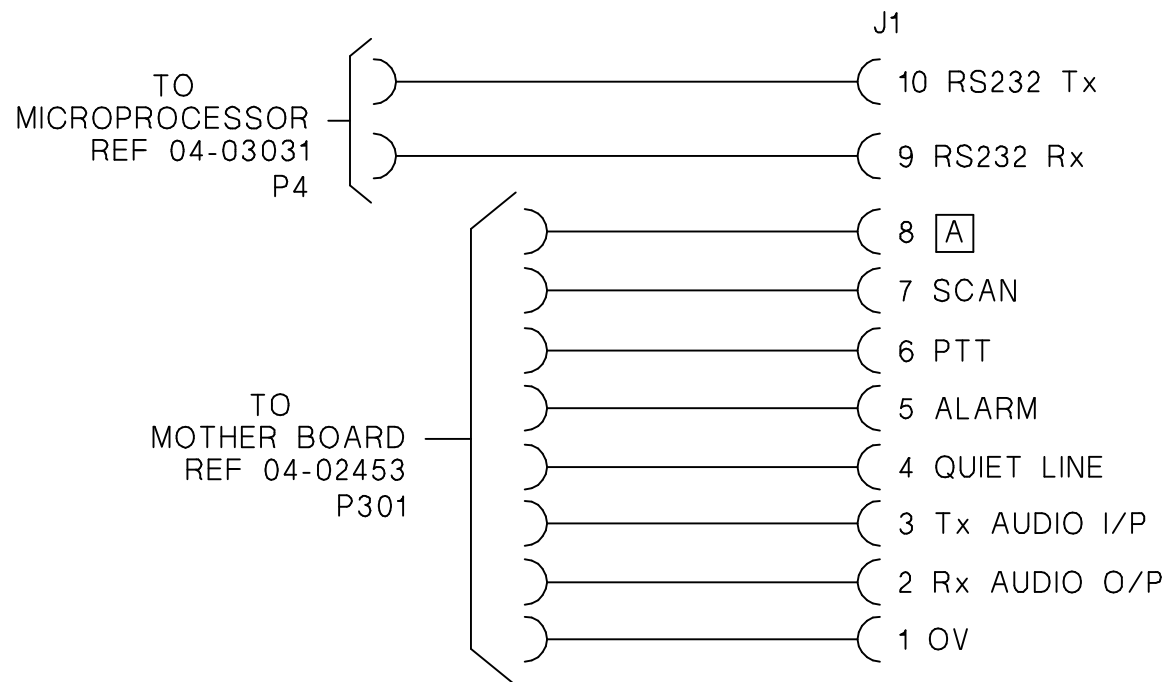

DIMENSIONS IN mm

FILE No.
15\10412__C.DWG

		SCALE NTS	© CODAN PTY LTD, A.C.N. 007 590 605: 2000			
	DRN	ILT	DATE 17-3-94	TITLE FITTING INSTRUCTIONS OPTIONS RS 8528		
MATERIAL	CHKD	NJA	21-3-94	DRAWING/DOC NO.		
FINISH	APPD			A3	15-10412-001	
	TOLERANCES UNLESS OTHERWISE STATED			ISS		
	2 PLACES DEC.	±0.10		A	B	C
	1 PLACE DEC.	±0.5				
	0 PLACE DEC.	±1				
						SHT. 1 OF 1