ADVANTEST®

ADVANTEST CORPORATION

U3641 Series

Spectrum Analyzer

Operation Manual

MANUAL NUMBER FOE-8311266K00

Applicable models

U3641
U3641PHS
U3641N

Safety Summary

To ensure thorough understanding of all functions and to ensure efficient use of this instrument, please read the manual carefully before using. Note that Advantest bears absolutely no responsibility for the result of operations caused due to incorrect or inappropriate use of this instrument.

If the equipment is used in a manner not specified by Advantest, the protection provided by the equipment may be impaired.

- **Warning Labels**

Warning labels are applied to Advantest products in locations where specific dangers exist. Pay careful attention to these labels during handling. Do not remove or tear these labels. If you have any questions regarding warning labels, please ask your nearest Advantest dealer. Our address and phone number are listed at the end of this manual.

Symbols of those warning labels are shown below together with their meaning.

DANGER: Indicates an imminently hazardous situation which will result in death or serious personal injury.

WARNING: Indicates a potentially hazardous situation which will result in death or serious personal injury.

CAUTION: Indicates a potentially hazardous situation which will result in personal injury or a damage to property including the product.

- **Basic Precautions**

Please observe the following precautions to prevent fire, burn, electric shock, and personal injury.

- Use a power cable rated for the voltage in question. Be sure however to use a power cable conforming to safety standards of your nation when using a product overseas.
- When inserting the plug into the electrical outlet, first turn the power switch OFF and then insert the plug as far as it will go.
- When removing the plug from the electrical outlet, first turn the power switch OFF and then pull it out by gripping the plug. Do not pull on the power cable itself. Make sure your hands are dry at this time.
- Before turning on the power, be sure to check that the supply voltage matches the voltage requirements of the instrument.
- Be sure to plug the power cable into an electrical outlet which has a safety ground terminal. Grounding will be defeated if you use an extension cord which does not include a safety ground terminal.
- Be sure to use fuses rated for the voltage in question.
- Do not use this instrument with the case open.

- Do not place objects on top of this product. Also, do not place flower pots or other containers containing liquid such as chemicals near this product.
- When the product has ventilation outlets, do not stick or drop metal or easily flammable objects into the ventilation outlets.
- When using the product on a cart, fix it with belts to avoid its drop.
- When connecting the product to peripheral equipment, turn the power off.

- **Caution Symbols Used Within this Manual**

Symbols indicating items requiring caution which are used in this manual are shown below together with their meaning.

DANGER: Indicates an item where there is a danger of serious personal injury (death or serious injury).

WARNING: Indicates an item relating to personal safety or health.

CAUTION: Indicates an item relating to possible damage to the product or instrument or relating to a restriction on operation.

- **Safety Marks on the Product**

The following safety marks can be found on Advantest products.

 : ATTENTION - Refer to manual.

 : Protective ground (earth) terminal.

 : DANGER - High voltage.

 : CAUTION - Risk of electric shock.

- **Replacing Parts with Limited Life**

The following parts used in the instrument are main parts with limited life.

Replace the parts listed below after their expected lifespan has expired.

Note that the estimated lifespan for the parts listed below may be shortened by factors such as the environment where the instrument is stored or used, and how often the instrument is used.

There is a possibility that each product uses different parts with limited life. For more information, refer to Chapter 1.

Main Parts with Limited Life

Part name	Life
Unit power supply	5 years
Fan motor	5 years
Electrolytic capacitor	5 years
LCD panel	6 years
LCD backlight	2.5 years
Floppy disk drive	5 years

- **Precautions when Disposing of this Instrument**

When disposing of harmful substances, be sure dispose of them properly with abiding by the state-provided law.

Harmful substances: (1) PCB (polycarbon biphenyl)
 (2) Mercury
 (3) Ni-Cd (nickel cadmium)
 (4) Other

Items possessing cyan, organic phosphorous and hexadic chromium and items which may leak cadmium or arsenic (excluding lead in solder).

Example: fluorescent tubes, batteries

Environmental Conditions

This instrument should only be used in an area which satisfies the following conditions:

- An area free from corrosive gas
- An area away from direct sunlight
- A dust-free area
- An area free from vibrations

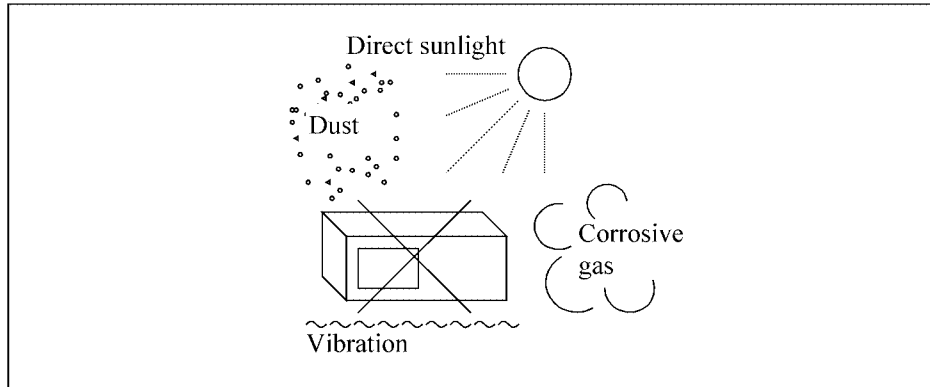

Figure-1 Environmental Conditions

- Instrument Placement

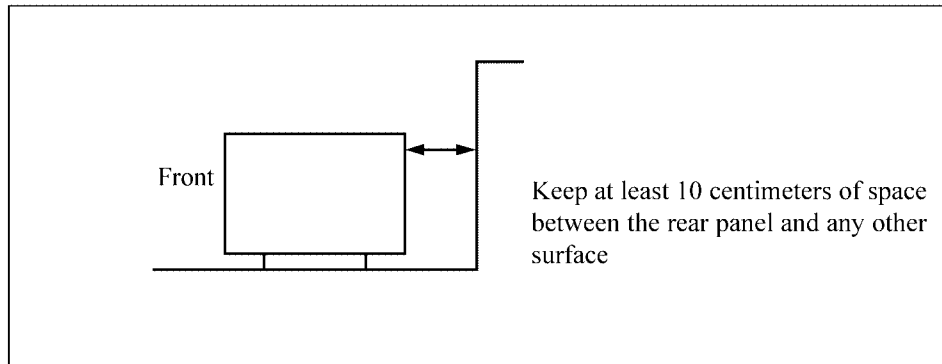

Figure-2 Instrument Placement

This instrument can be used safely under the following conditions:

- Altitude of up to 2000 m
- Installation Categories II
- Pollution Degree 2

MANUAL CHANGES

ADVANTEST CORPORATION

Date	Sep 21/98	Manual number	FOE-8311266H00 or later
Manual Name	U3641 Series Operation Manual	Manual Change No.	EMC-02

When using Option 73 in this analyzer, attach noise suppression cores on the cables to suppress EMI noise.

- (1) Adding noise suppression cores to the standard accessories
The following parts have been added to the standard accessories to make the instrument compliant with EMI.

Accessory Name	Model Number	Quantity
Core	SFC-4	9
	ESD-SR-15	1
Cable tie	T18R	3

- (2) Attaching the cores to the cables
For the connectors shown below, attach the core near the plug on the U3641 side.

Note: When the core appears to be loose, use the provided cable tie to secure it in place.

Connector	Core used
10MHz REF IN / CAL OUT	SFC-4
EXT TRIG	
GATE IN	
COMP VIDEO	
VIDEO OUT	
VIDEO IN	
SOUND OUT	
SOUND IN	
PHONE	
AC Power supply	ESD-SR-15

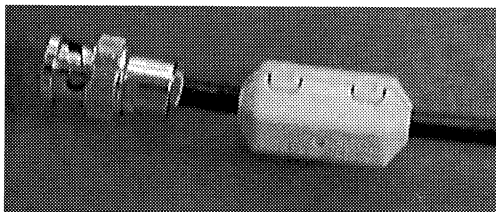

Core attached to the Cable

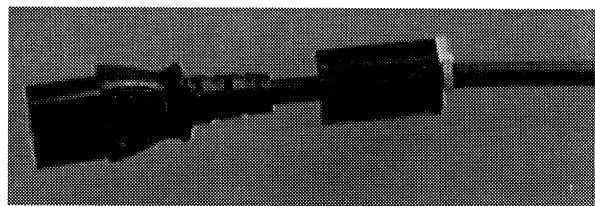

Core and Cable Tie attached to the Cable

Certificate of Conformity

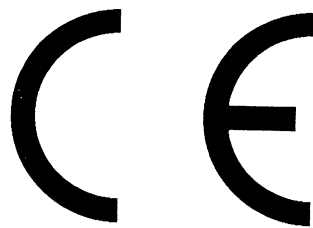

This is to certify, that

Spectrum Analyzer

U3641 Series

instrument, type, designation

complies with the provisions of the EMC Directive 89/336/EEC in accordance with EN50081-1 and EN50082-1 and Low Voltage Directive 73/23/EEC in accordance with EN61010.

ADVANTEST Corp

Tokyo, Japan

ROHDE&SCHWARZ



Engineering and Sales GmbH

Munich, Germany

Table of Power Cable Options

There are six power cable options (refer to following table).

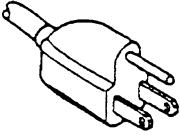
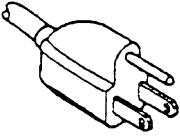
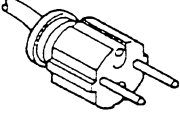
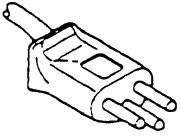
Order power cable options by Model number.

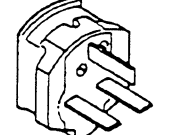
	Plug configuration	Standards	Rating, color and length	Model number (Option number)
1		JIS: Japan Law on Electrical Appliances	125 V at 7 A Black 2 m (6 ft)	Straight: A01402 Angled: A01412
2		UL: United States of America CSA: Canada	125 V at 7 A Black 2 m (6 ft)	Straight: A01403 (Option 95) Angled: A01413
3		CEE: Europe DEMKO: Denmark NEMKO: Norway VDE: Germany KEMA: The Netherlands CEBEC: Belgium OVE: Austria FIMKO: Finland SEMKO: Sweden	250 V at 6 A Gray 2 m (6 ft)	Straight: A01404 (Option 96) Angled: A01414
4		SEV: Switzerland	250 V at 6 A Gray 2 m (6 ft)	Straight: A01405 (Option 97) Angled: A01415
5		SAA: Australia, New Zealand	250 V at 6 A Gray 2 m (6 ft)	Straight: A01406 (Option 98) Angled: -----
6		BS: United Kingdom	250 V at 6 A Black 2 m (6 ft)	Straight: A01407 (Option 99) Angled: A01417

PREFACE

1. This manual configuration

Part 1. Operating Instruction

Following options also are explained

- TV demodulation function (OPT72)
- TV channel function (OPT78)
- Tracking generator function

Part 2. Explanation of PHS-ID demodulation function (U3641PHS only)

2. Selection Guide

Function Model name	High Stab Reference function	Narrow RBW function	TV Picture monitor function	Tracking Generator function	TV Channel setting function
U3641/3641N *1	OPT20	OPT26	OPT72 *2	OPT74	OPT78 *2
U3641PHS *1		OPT26		OPT74	

*1 Input Impedance of U3641/3641PHS is 50Ω.
Input Impedance of U3641N is 75Ω.

*2 Option 72 include option 78.

キャリング・ベルト使用上の注意

Caution in using carrying belt

(1)正しいベルトの着脱方法 Attachment of the belt

脱

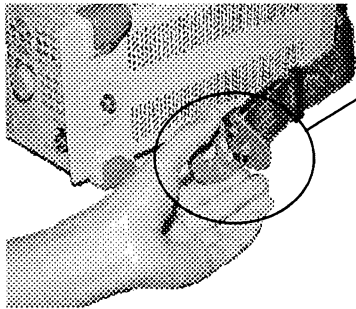

ベルトのレバーを
起こします。
Raise the lever of the
belt.

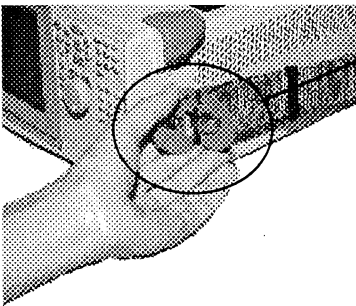

本体の突起に掛けます。
Hang the lever to
the projections of
the main unit.

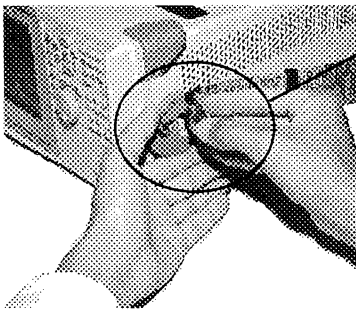

レバーに無理な力を
加えぬよう注意して
下さい。
Be careful not to give
excessive power to the
lever.

着



誤操作 Misoperation

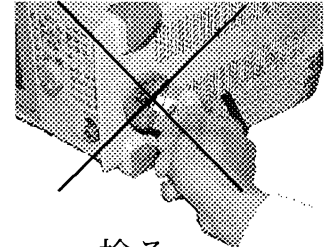

捻る Twisting

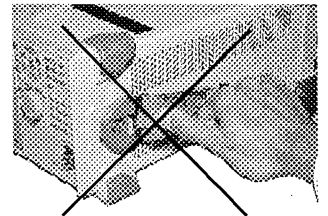

押す Pushing

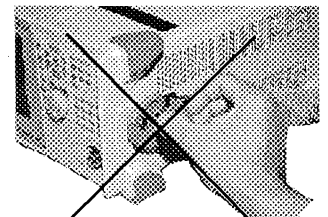

引く Pulling

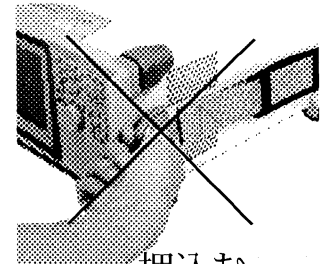

押込む Pushing in

(2)装着後の確認 Check after attaching the belt

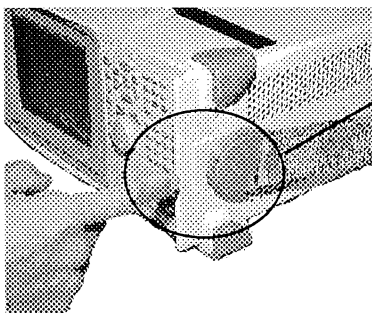

装着後 異常なガタつき／隙間が無いか
確認して下さい。

After attaching, make certain of any abnormal
rattle or gap.

Part 1
Spectrum Analyzer
OPERATION MANUAL

TABLE OF CONTENTS

1. ANALYZER FEATURES AND SPECIFICATIONS	1-1
1.1 Outline of the Analyzer	1-1
1.2 Options of List	1-3
1.3 Accessories of List	1-3
1.4 Replacing Parts with Limited Life	1-4
2. BEFORE USING THE FIRST TIME	2-1
2.1 Checking Accessories	2-1
2.2 Environmental conditions	2-2
2.3 Installation	2-3
2.4 Storing, Cleaning and Transporting	2-4
2.5 Before Turning the Power On	2-5
2.5.1 Power Source	2-5
2.5.2 Using Battery	2-6
2.5.3 Using the AC/DC Adapter	2-6
2.5.4 Using DC Power Supply	2-8
2.6 After the Power-on	2-10
3. PANELS	3-1
3.1 Front Panel	3-1
3.2 Rear Panel	3-6
3.3 Top Panel	3-8
4. EASY USE INSTRUCTIONS	4-1
4.1 Initial Power-up	4-1
4.2 From starting Measurement to Finishing it	4-4
5. METHOD OF OPERATION	5-1
5.1 Key description	5-1
5.1.1 Softkeys	5-1
5.1.2 Function section	5-2
5.1.3 DATA ENTRY section	5-3
5.2 Output to Screen Data	5-4
5.2.1 Plotter Output	5-4

SPECTRUM ANALYZER
OPERATION MANUAL

Table of Contents

5.2.2 Printer Output	5-12
5.2.3 Memory Card Output	5-17
5.2.4 Video Printer Output	5-17b
5.3 Saving Data to Memory Card	5-18
5.3.1 Condition of Memory Card	5-18
5.3.2 To Use Memory Card	5-20
5.3.3 Cautions in Handling Memory Card	5-29
5.4 RS-232 Remote Control Function	5-30
5.4.1 RS-232 Specifications	5-31
5.4.2 Connection	5-32
5.4.3 Communication Port Setting	5-34
5.4.4 Message Format	5-37
5.4.5 RS-232 Remote Programming Examples	5-39
5.4.6 Data Communication Errors	5-52
5.4.7 Exceptional Processing	5-53
6. MEASUREMENT METHOD	6-1
6.1 Common Detailed Informations to All Measurements	6-1
6.1.1 Input Frequency Range and Resolution	6-1
6.1.2 Maximum Input Level and Dynamic Range	6-3
6.2 Frequency Measurement	6-10
6.2.1 Normal Marker Frequency Measurement	6-10
6.2.2 Frequency Counter Mode Frequency Measurement	6-10
6.3 Level Measurement	6-11
6.3.1 Second Order Harmonic Distortion Measurement	6-11
6.3.2 Third Order Intermodulation Distortion Measurement	6-13
6.3.3 Measuring Small Signal Level	6-15
6.4 Modulation Signal Measurements	6-16
6.4.1 AM Signal Analysis	6-16
6.4.2 FM Signal Analysis	6-20
6.4.3 Measuring Pulse Modulated Signals	6-27
6.5 Occupied Bandwidth (OBW) Measurement	6-30
6.6 Adjacent Channel Leakage Power (ACP) Measurement	6-32
6.7 Television Carrier Signal Measurements	6-36
6.7.1 V/A Measurement	6-37
6.7.2 Satellite Broadcast Signal C/N Measurement	6-39
6.8 Analyzing Burst Signal Spectra	6-43

7. FUNCTION DESCRIPTIONS	7-1
7.1 Functions of the Fundamental Keys	7-1
7.1.1 Center Frequency	7-2
7.1.2 Frequency Span	7-2
7.1.3 START, STOP Frequencies	7-3
7.1.4 Reference Level	7-4
7.1.5 Couple Key (CPL)	7-6
7.1.6 Menu Key	7-7
7.2 TRACE Functions	7-19
7.2.1 Trace Modes	7-20
7.2.2 Averaging Mode (Trace A Only)	7-22
7.2.3 Calculation Modes	7-24
7.2.4 Normalize Mode (Trace A Only)	7-25
7.3 Marker Functions	7-26
7.3.1 Marker ON	7-26
7.3.2 Peak Search	7-32
7.3.3 MARKER →(Marker to)	7-35
7.3.4 Marker OFF	7-36
7.4 Measurement (MEAS) function	7-37
7.4.1 MEAS1	7-37
7.4.2 MEAS2	7-48
7.5 User-Defined Functions	7-56
7.6 Save/Recall Functions of Memory Card	7-60
7.6.1 Memory Card Functions	7-61
7.6.2 Save Function	7-66
7.6.3 Recall Function	7-68
7.7 Preset Function	7-70
7.8 Configuration (CONFIG) Function (Initialization Function)	7-71
7.8.1 Printer/Plotter Configuration Setup	7-72
7.8.2 DATE Function	7-75
7.8.3 Power OFF Function	7-76
7.8.4 RS-232 Interface Communication Port Setup	7-77
7.8.5 Switching External/Internal of 10 MHz Frequency Reference Source	7-78
7.8.6 CPU check function	7-79
7.8.7 Battery Check Function	7-80
7.9 Copy Function	7-82
7.10 Calibration Function	7-83
7.11 Label Function	7-86

7.12 Utility Functions	7-89
7.12.1 Antenna Factor Correction	7-89
7.12.2 Limit Line Function	7-91
7.12.3 PASS/FAIL Function (Display Trace Go/No go Test Function)	7-96
7.13 Measurement Window Function	7-98
8. TV MONITOR FUNCTION (OPT-72)	8-1
8.1 Notes on Using TV Monitoring Function	8-1
8.2 Display of TV Monitor Screen	8-3
8.3 Adjustment of TV Monitor Screen	8-5
9. TV CHANNEL FUNCTION (OPT-72, OPT-78)	9-1
9.1 Channel Setup (TV Key)	9-1
9.1.1 Operation method	9-5
9.2 Channel Table Allocation (SHIFT Key + TV Key)	9-11
9.3 Frequency Span Setup	9-13
9.4 Marker Channel number display	9-15
9.5 TV Channel Table	9-16
9.5.1 TV Standard Mode	9-16
9.5.2 Channel Table Title by Band	9-17
9.5.3 Channel Table List by Country	9-20
10. TRACKING GENERATOR FUNCTION (OPT-74)	10-1
10.1 Usage of Tracking Generator	10-2
10.2 How to Normalize a Frequency Characteristic with Reference to a Display Line	10-4
10.3 Measurement Example of a Filter's Damping Property	10-6
10.4 Handling Precautions of Tracking Generator	10-13
11. GPIB	11-1
11.1 Overview of the GPIB	11-1
11.2 GPIB Specifications	11-3
11.3 Initializing the Analyzer	11-7
11.3.1 Setting the Analyzer's GPIB Address	11-7
11.3.2 Defining the Delimiter	11-7
11.4 Remote setup (Listener)	11-8
11.5 Data output (Talker)	11-13
11.6 Inputting and Outputting Trace Data	11-18

SPECTRUM ANALYZER
OPERATION MANUAL

Table of Contents

11.7 Service Request (SRQ)	11-25
11.8 Setup Example of TV Channel Function (OPT-72)	11-31
12. IN OCCURRENCE OF A TROUBLE	12-1
13. SPECIFICATIONS	13-1
13.1 U3641/U3641PHS	13-1
13.2 U3641N	13-9
13.3 U3641/U3641PHS/U3641N Option	13-16
APPENDIX	A-1
A.1 Glossary	A-1
A.2 dB Conversion Formulas	A-8
A.3 Menu Lists	A-9
A.3.1 Softkey Menu	A-9
A.4 List of Messages	A-16
DIMENSIONAL OUTLINE DRAWING	EXT-1
ALPHABETICAL INDEX	I-1

**SPECTRUM ANALYZER
OPERATION MANUAL**

List of Illustrations

LIST OF ILLUSTRATIONS

<u>No.</u>	<u>Title</u>	<u>Page</u>
2-1	Environmental Conditions	2-2
2-2	Installation Conditions	2-3
2-3	Battery pack	2-6
2-4	AC/DC adapter (A08364)	2-6
2-5	AC/DC adapter and battery connection diagram	2-7
2-6	DC power supply connection diagram	2-9
2-7	Checking the fuse	2-10
3-1	Front panel	3-1
3-2	Rear Panel	3-6
3-3	Top Panel	3-8
4-1	Battery connection	4-1
4-2	Power ON/OFF	4-2
4-3	Measurement setup	4-4
4-4	Panel keys and softkeys	4-5
4-5	Details on Screen Display	4-7
4-6	Data input	4-7
5-1	Softkey menu and softkeys	5-1
5-2	Panel keys in the function section	5-2
5-3	DATA ENTRY section part of the front panel	5-3
5-4	Plotter connection diagram (Example of the analyzer and R9833 connection)	5-4
5-5	Plotter DIP switch settings	5-5
5-6	Plotter configuration window	5-6
5-7	Plotter type selection	5-6
5-8	Plotter mode selection	5-6
5-9	TABLE data type selection	5-7
5-10	Paper size selection	5-8
5-11	Pen count selection	5-8
5-12	Display division selection	5-9
5-13	Output location selection (two pictures case)	5-10
5-14	Output location selection(four pictures case)	5-10
5-15	Switching the output location between AUTO and MANUAL	5-10
5-16	Talk only / address	5-11

**SPECTRUM ANALYZER
OPERATION MANUAL**

List of Illustrations

No.	Title	Page
5-17	Printer connection diagram (Example of the analyzer and HP2225AJ connection) .	5-12
5-18	Printer address selection dip switch	5-13
5-19	Printer connection diagram (Example of the analyzer and VP-600 connection) . . .	5-14
5-20	RS-232 cable connection diagram for the direct connection	5-15
5-21	RS-232 cable connection diagram for the connection using a serial-to-parallel converter	5-15
5-22	Video printer connection diagram	5-17b
5-23	Memory card (A09507)	5-19
5-24	Memory card insertion and extraction	5-20
5-25	Memory card initialization menu	5-21
5-26	SAVE function menu	5-23
5-27	Initial value of save conditions	5-25
5-28	RECALL function menu (in NORMAL mode)	5-27
5-29	RECALL DEFINE menu screen	5-28
5-30	Connection to personal computer	5-32
5-31	Cable connection diagram	5-33
5-32	Window screen for communication port setting	5-34
5-33	Transmission speed setting	5-34
5-34	Data length setting	5-34
5-35	Stop bit setting	5-35
5-36	Parity bit setting	5-35
5-37	Data flow control setting	5-35
5-38	Interval time setting	5-36
5-39	Communication port open setting	5-36
5-40	Communication port close setting	5-36
6-1	Using the largest possible IF bandwidth that two signals can be resolved	6-1
6-2	Using a very narrow RBW that two signals are completely separated	6-1
6-3	VBW = 1 MHz	6-2
6-4	VBW = 1 kHz	6-2
6-5	SWP = 4 s	6-3
6-6	SWP = 100 ms	6-3
6-7	1 dB gain compression point	6-6
6-8	Second order harmonic distortion	6-8
6-9	Third order intermodulation distortion	6-8
6-10	Normal marker Measurement	6-10
6-11	Frequency counter Measurement	6-10
6-12	Connection of second order harmonic distortion measurement	6-11
6-13	Measuring the fundamental frequency component amplitude	6-12

**SPECTRUM ANALYZER
OPERATION MANUAL**

List of Illustrations

No.	Title	Page
6-14	Second order harmonic distortion measurement	6-13
6-15	Third order intermodulation distortion measurement	6-13
6-16	Third order intermodulation distortion	6-14
6-17	Pre-amplifier OFF	6-15
6-18	Pre-amplifier ON	6-15
6-19	AM signal measurement	6-16
6-20	AM modulation index	6-18
6-21	Modulation frequency of an AM signal	6-18
6-22	AM modulation accuracy	6-19
6-23	Sideband level	6-19
6-24	FM signal analysis	6-21
6-25	FM signal with low modulation frequency	6-23
6-26	FM signal with high modulation frequency	6-23
6-27	FM signal with small Δf_{peak}	6-24
6-28	FM signal with large Δf_{peak}	6-24
6-29	FM signal with small modulation index m	6-26
6-30	Pulse modulation	6-27
6-31	OBW measurement	6-31
6-32	ACP POINT mode measurement of adjacent channel leakage power	6-34
6-33	ACP GRAPH mode measurement of adjacent channel leakage power	6-35
6-34	NTSC signal (1 channel)	6-36
6-35	NTSC signal (12 channel)	6-36
6-36	VHF and UHF channel assignments	6-37
6-37	V/A measurement	6-38
6-38	Picture quality vs C/N	6-39
6-39	Carrier signal level measurement	6-41
6-40	Noise level measurement	6-42
7-1	Front panel fundamental keys	7-1
7-2	Display legends	7-1
7-3	TRIGGER position	7-9
7-4	Using a VIDEO trigger to display a waveform	7-10
7-5	Color definition window screen	7-15
7-6	Color setting window	7-18
7-7	Trace key on front panel	7-19
7-8	WRITE and VIEW trace modes	7-20
7-9	No averaging	7-22
7-10	Averaging 20 times	7-22
7-11	The MARKER section on front panel	7-26

**SPECTRUM ANALYZER
OPERATION MANUAL**

List of Illustrations

No.	Title	Page
7-12	Active marker and fixed marker	7-27
7-13	ΔMarker level % display	7-28
7-13a	Sample of Multi Marker List Display	7-28b
7-14	Noise/Hz measurement	7-29
7-15	Marker movement between trace A and B	7-31
7-16	Next peak search execution	7-33
7-17	ΔY setting	7-34
7-18	UP setting	7-34
7-19	LOW setting	7-34
7-20	Location of measurement keys on the front panel	7-37
7-21	Waveform at the setup mode. (The window is moved to a part to be expanded.)	7-39
7-22	Waveform measured with DELAY SWEEP ON (The window part is expanded.) ...	7-39
7-23	DELAY POSITION	7-42
7-24	DELAY SWEEP TIME	7-42
7-25	Setup mode (DELAY SWEEP OFF)	7-42
7-26	Measurement mode(DELAY SWEEP ON)	7-42
7-27	Measurement method	7-43
7-28	GATE WINDOW	7-44
7-29	Peak List 1	7-45
7-30	Single Sweep	7-47
7-31	X dB down	7-48
7-32	Third order intermodulation distortion measurement	7-50
7-33	AM modulation wave spectrum (Log scale)	7-51
7-34	AM modulation wave spectrum (Linear scale)	7-52
7-35	AM modulation accuracy measurement in time domain	7-52
7-36	Location of the user-defined key on the front panel	7-56
7-37	User-defined display	7-56
7-38	Save/Recall function keys of the memory card on the front panel	7-60
7-39	File list display	7-60
7-40	Saved file contents display with SHOW FILE function	7-62
7-41	Front panel preset function key	7-70
7-42	Front panel CONFIG key	7-71
7-43	The power supply voltage is in a normal state at DC CHECK ON. When it is not in a normal state, the display blinks and the buzzer sounds.	7-80
7-44	When the power supply voltage is low at DC CHECK OFF, the display blinks. ...	7-80
7-45	COPY function key on Front panel	7-82
7-46	Calibration function key on Front panel	7-83
7-47	LABEL function key or Front panel	7-86

**SPECTRUM ANALYZER
OPERATION MANUAL**

List of Illustrations

No.	Title	Page
7-49	Label display ON	7-88
7-50	Label display OFF	7-88
7-51	Front panel UTILITY function key	7-89
7-52	TR1722 antenna factor	7-89
7-53	Limit line data entry	7-91
7-54	Table edit mode	7-93
7-55	PASS/FAIL function (Using a single limit line.)	7-96
7-56	PASS/FAIL function (Using both limit lines.)	7-96
7-57	Front panel measurement window function key	7-98
7-58	Measurement window initialization screen	7-98
7-59	Window position movement (X→X')	7-99
7-60	Window width increase/decrease ($\Delta X \rightarrow \Delta X'$)	7-99
7-61	Partial sweep inside the window	7-101
7-62	Continuous peak search inside the window	7-101
8-1	Relationship between input signal level and S/N ratio	8-1
8-2	Indications and input of channel number	8-3
8-3	Tuning level display	8-7
9-1	Start frequency/Stop frequency setup	9-1
9-2	Relation between lower limit and upper limit of frequency bandwidth	9-2
9-3	Difference between the present setup value and the displayed value	9-3
9-4	Display when user table is not set	9-3
9-5	USER table	9-4
9-6	USER2 table	9-4
9-7	Channel input mode screen	9-5
9-8	User channel setup screen	9-7
9-9	Setup example	9-11
9-10	Center channel setup example (VHF in Japan)	9-14
9-11	Channel number display screen	9-15
10-1	Clear Screen	10-7
10-2	Normalize Screen	10-8
10-3	Sweep Time for 2 Seconds	10-9
10-4	Measurement of an Insertion Loss	10-10
10-5	Measurement of a Passing Bandwidth	10-11
10-6	Measurement of an Attenuation	10-12

**SPECTRUM ANALYZER
OPERATION MANUAL**

List of Illustrations

<u>No.</u>	<u>Title</u>	<u>Page</u>
11-1	GPIB bus configuration	11-3
11-2	GPIB connector pin assignment	11-4
11-3	Signal line termination	11-5
11-4	Relation between screen grid and data points	11-18
A-1	IF Bandwidth	A-1
A-2	Reference Level	A-2
A-3	Occupied Bandwidth	A-3
A-4	Spurious Response	A-4
A-5	Noise Sideband	A-5
A-6	Bandwidth Selectivity	A-6
A-7	Bandwidth Switching Accuracy	A-6
A-8	VSWR	A-7

LIST OF TABLES

No.	Title	Page
2-1	Standard accessories	2-1
2-2	AC power requirements	2-7
2-3	Analyzer DC power requirements	2-9
5-1	List of plotters that can be used with the analyzer	5-4
5-2	Plot mode	5-7
5-3	Table data	5-7
5-4	Plotter pen assignments	5-9
5-5	List of printers that can be used with the analyzer (ESC/P language)	5-14
5-6	Memory Card Specifications	5-19
5-7	Signal names of serial input/output interfaces	5-33
5-8	List of Control Character Codes	5-38
5-9	Control codes for status byte	5-47
5-10	Status byte information	5-47
5-11	Control codes for status byte	5-51
6-1	Maximum input level	6-4
6-2	Average display noise level	6-5
6-3	1 dB gain compression (Frequency 10 MHz or more)	6-6
6-4	Spurious response	6-9
6-5	Residual response	6-9
7-1	Reference level setting range	7-4
7-2	Color table mode	7-17
7-3	Factory initial setup	7-70
9-1	TV mode and scan line number	9-16
9-2	TV standard mode	9-16
9-3	Channel table of VHF	9-17
9-4	Channel table of UHF	9-17
9-5	Channel table of CATV	9-18
9-6	Channel table of BS	9-18
9-7	Channel table of CS (Japan)	9-19
9-8	Channel table of VHF in Japan	9-20
9-9	Channel table of UHF in Japan	9-20
9-10	Channel table of CATV in Japan	9-22
9-11	Channel table of BS in Japan	9-24

**SPECTRUM ANALYZER
OPERATION MANUAL**

List of Tables

<u>No.</u>	<u>Title</u>	<u>Page</u>
9-12	Channel table of CS in Japan (V:TYPE1)	9-24
9-13	Channel table of CS in Japan (V:TYPE2)	9-25
9-14	Channel table of CS in Japan (V:SOUND)	9-25
9-15	Channel table of CS in Japan (H:TYPE1)	9-26
9-16	Channel table of CS in Japan (H:TYPE2)	9-27
9-17	Channel table of CS in Japan (H:TV)	9-27
9-18	Channel table of CS in Japan (SCC V:TYPE1)	9-28
9-19	Channel table of CS in Japan (SCC V:TYPE2)	9-28
9-20	Channel table of CS in Japan (SCC V:TV)	9-29
9-21	Channel table of CS in Japan (SCC H:TYPE1)	9-29
9-22	Channel table of CS in Japan (SCC H:TYPE2)	9-30
9-23	Channel table of VHF in China	9-31
9-24	Channel table of UHF in China	9-31
9-25	Channel table of VHF in east Europe	9-33
9-26	Channel table of UHF in east Europe	9-33
9-27	Channel table of CATV in east Europe	9-35
9-28	Channel table of VHF in France	9-36
9-29	Channel table of UHF in France	9-36
9-30	Channel table of CATV (CCETT) in France	9-38
9-31	Channel table of CATV (TETECOM) in France	9-39
9-32	Channel table of VHF in Italy	9-40
9-33	Channel table of CATV in Korea	9-41
9-34	Channel table of VHF in Singapore	9-43
9-35	Channel table of VHF in Malaysia	9-43
9-36	Channel table of VHF in U.S.A	9-43
9-37	Channel table of UHF in U.S.A	9-44
9-38	Channel table of CATV in U.S.A	9-46
9-39	Channel table of VHF in west Europe	9-49
9-40	Channel table of UHF in west Europe	9-49
9-41	Channel table of CATV in west Europe	9-51
11-1	Analyzer GPIB interface codes	11-6
11-2	Delimiter specification codes	11-7
11-3	Trace accuracy codes	11-18
11-4	Inputting and Outputting Trace Data	11-19
11-5	Service request ON/OFF codes	11-25
11-6	Status register bit assignments	11-25
11-7	Examples or data entry (GPIB codes with asterisk)	11-59

1. ANALYZER FEATURES AND SPECIFICATIONS

This chapter covers the basic specifications and the main features of the analyzer.

1.1 Outline of the Analyzer

U3641/3641PHS/3641N is a portable spectrum analyzer that allows analysis with high stability by the adoption of a synthesized local oscillator.

The U3641/3641PHS has the input impedance of 50Ω and the U3641N has 75Ω.

To further increase portability there are three power supply choices: a battery pack, AC/DC adapter or an external DC supply.

This allows a variety of power configurations.

The 6 inch TFT color LCD display greatly improves the efficiency of waveform observation.

By using the internal preamplifier, this analyzer's strength comes into play for the analysis of the micro level signal.

Performance Specifications:

Item		U3641/3641PHS (50Ω)	U3641N (75Ω)
Frequency range:		9 kHz to 3 GHz	9 kHz to 3 GHz
Input signal level (100 dB range presented in a single display)	Preamp. ON	- 135dBm to +13dBm	- 22dB μ V to +120dB μ V
	Preamp. OFF	- 117dBm to +27dBm	- 8dB μ V to +134dB μ V
Maximum resolution		1 kHz (100Hz at option)	1 kHz (100Hz at option)
Sideband Noise (measured 20 kHz from the carrier)		- 105 dBc/Hz	- 105 dBc/Hz
Residual FM		60Hz p-p/100ms	60Hz p-p/100ms

Feature list:

- ① Small size and lightmass
Approx. 148 mm (height) × 291 mm (width) × 330 mm (depth).
Main unit approximately 6.9 kg (nominal) (except battery of approximately 1.1 kg)
- ② Three power supply sources
Power supply choices are battery, AC/DC Adapter or an external DC supply. The full charged battery provide 1.5 hours operation of continuous operation. Note that a PROPAC14 battery is used in full charge state and normal temperature, and the I/O port block power of the analyzer is turned OFF and the intensity is minimum state.
- ③ In the Zero Span mode, the sweep time of 50 μ sec can be set. Accordingly, time-axis analysis of the burst wave becomes possible.
- ④ 6 inch color LCD display, allowing a 100 dB scale display
A six inch color LCD easily shows multiple wave data and a 100dB scale display.
- ⑤ Preamplifier
The preamplifier is equipped with the gain of 20dB or more in the frequency range of 9 kHz to 2.2 GHz. By using the preamplifier, this analyzer's plays for the analysis of the micro level signal.
- ⑥ Easy operation by having two-slot card cage
Up to 2 memory cards can be used simultaneously to hold data etc.
IC memory cards were originally proposed by memory manufacturers, but standardization is being advanced by the Japan Electronic Industry Development Association and the Electronics Industry Association in the US. For use in the U3641/3641PHS/3641N Cards should conform either to the JEIDA IC Memory Card Guideline Version 4.1, or to the PCMCIA Release 2.0 Specification.
- ⑦ Audio and video outputs available
Monitoring of AM or FM audio signals is possible, using a built-in speaker. The video output (composite signal) of NTSC standard is equipped. There is also an output signal for this video available for connection to an external video printer to make hard copy of display waveforms easy.

**SPECTRUM ANALYZER
OPERATION MANUAL**

1.2 Options of List

⑧ Remote control via RS-232 or GPIB

The analyzer can be remotely controlled by either an RS-232 serial connection or a GPIB parallel port. Thus the analyzer can also be incorporated into a larger measurement system. When using GPIB output can be directed to printer or plotter.

⑨ Accessory and peripheral equipment

In addition to a battery pack, memory card, the abundant accessories such as a carrying bag and a case are available.

1.2 Options of List

OPT-20	High-stable reference oscillator	$\pm 2 \times 10^{-8}$ /day $\pm 1 \times 10^{-7}$ /year
OPT-26	Narrow RBW	300Hz, 100Hz
OPT-72	TV Picture Monitor	
OPT-74	Tracking generator	100kHz to 2.2GHz
OPT-78	Channel Setting	

OPT-20 and OPT-72 : Can not be installed in U3641PHS.

OPT-78 : Involved in OPT-72.

1.3 Accessories of List

R16072	Transit case
R16216	Carring case
R16601	Display hood
A02806	Front cover
A08184	Front Handle
A09507	SRAM MEMORY CARD 64K Byte
CSCJ-256K-SM-461	SRAM MEMORY CARD 256K Byte
CSCJ-002M-SM-461	SRAM MEMORY CARD 2M Byte
PROPAC14BATT	Battery
DUAL CHARGER	Battery charger

1.4 Replacing Parts with Limited Life

The U3641 series uses the following parts with limited life that are not listed in Safety Summary. Replace the parts listed below after their expected lifespan has expired.

Part name	Life
Relay	5,000,000 times
Rotary encoder	100,000 cycle
Key switch	5,000,000 times

2. BEFORE USING THE FIRST TIME

This chapter covers the first step in setting up the analyzer and powering it up. Necessary precautions are also pointed out. Please read it before you use the analyzer the first time.

2.1 Checking Accessories

Table 2-1 lists the standard accessories shipped with the analyzer. If any of the accessories are damaged or missing, contact the nearest ADVANTEST Field Office or representative. Order accessories by type name or stock number.

Table 2-1 Standard accessories

Part name	Model	Quantity					Remarks
		U3641/ 3641PHS	U3641N	OPT-72 (TV)	OPT-74 (TG)	OPT-74 N TYPE (TG75Ω)	
AC/DC Adapter	A08364	1	1	—	—	—	
AC Power supply cable	*	1	1	—	—	—	
Power fuse	326010	1	1	—	—	—	
N-BNC conversion adapter	JUG-201A/U	1	—	—	1	—	50Ω
C15 type conversion adapter	NCP-NFJ	—	1	—	—	—	75Ω
NC-BNC type conversion adapter	BA-A165	—	1	—	—	1	
Memory card (64k byte SRAM)	A09507	—	—	1	—	—	
Carrying belt	—	1	1	—	—	—	
Operation manual (this manual)	EU3641	1	1	—	—	—	English

* : ADVANTEST provides the power cables for each country. (See yellow page of "Table of Power Options" at this manual.)

2.2 Environmental conditions

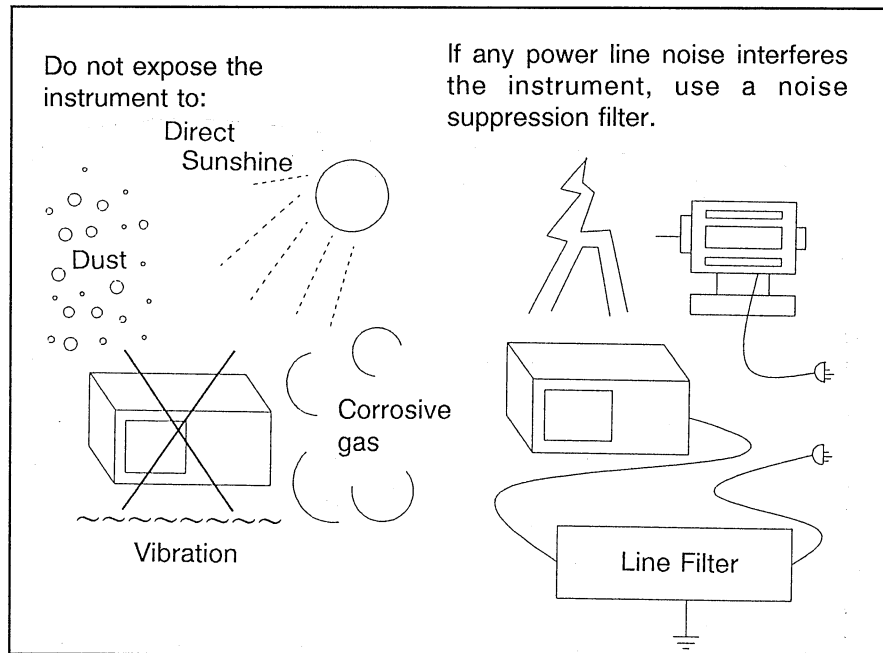

Figure 2-1 Environmental Conditions

You can store the analyzer in temperatures that range from -20°C to $+60^{\circ}\text{C}$. However, you must operate the spectrum analyzer in an ambient temperature range of 0°C to $+50^{\circ}\text{C}$ (with a relative humidity of 85% or less).

Do not subject the spectrum analyzer to the following:

- Corrosive gas
- Dust
- Vibration
- Direct sunshine
- Excessive power-line noise

This spectrum analyzer is designed to resist noise from AC power lines. You should still minimize power-line noise whenever possible. If necessary, install a noise-suppressing line filter.

For highly accurate measurement, turn the power ON after the instrument temperature has reached the room temperature level, and warm up the instrument for 30 minutes.

2.3 Installation

Air cooling fan of the exhaust type is built into the rear panel. Do not close this outlet.

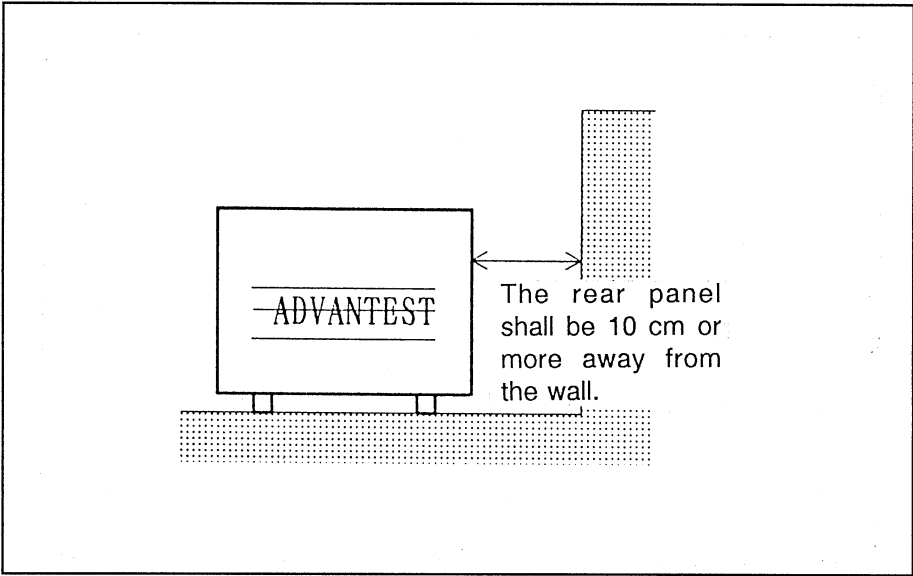

Figure 2-2 Installation Conditions

2.4 Storing, Cleaning, and Transporting

(1) Storing

Store the spectrum analyzer in an area in which the temperature is from -20°C to $+60^{\circ}\text{C}$. If you store the spectrum analyzer for a long period (more than 90 days), package the spectrum analyzer in a vapor-barrier bag with a drying agent.

Store the analyzer in a dust-free location out of direct sunlight.

(2) Cleaning

Remove dust from the outside of the analyzer by wiping or brushing the surface with a soft cloth or small brush. The brush will remove dust from around the front-panel keys. Hardened dirt can be removed with a cloth dampened in water that contains a mild detergent. Do not use abrasive cleaners.

CAUTION

Do not allow water to get inside the analyzer. Do not use organic cleaning solvents, such as benzene, toluene, xylene, acetone or similar compounds, because they may damage the plastic parts.

(3) Transporting

To carry the spectrum analyzer by hand, put it in a transit case. The transit case is available as an optional accessory.

When you ship the analyzer, use the original container and packing material. If the original package is not available, use the following repackaging guidelines:

- ① Wrap the analyzer with shock absorbing materials and then put it into a box.
- ② Wrap the accessories with shock absorbing materials and then put it into a same box.
- ③ Seal the container with shipping tape or a heavy-duty, industrial stapler.

2.5 Before Turning the Power On

2.5.1 Power Source

This analyzer can use three kinds of power sources, intended for outdoor use.

- Battery :
(Optionally available)
 - PROPAC14 Battery : manufactured by Anton Bauer
Mass : Approx. 2.1 kg
60WH Battery fuse : Time-lag, 12.5A, 250V
- AC line source :
(Standard)
 - AC/DC adapter : A08364
AC/DC adapter built-in fuse : Time lag, 4A, 250V
Mass : Approx. 1.1 kg
Supporting both 100 VAC system and 200 VAC system automatically.
- External DC power source : Use an external DC power cord, A01434.
(Optionally available)

WARNING

1. When using a battery:
Use a battery pack suitable for the battery mounter on the rear side of the analyzer.
An improper battery may damage the analyzer.
2. When using an AC/DEC power source:
An AC/DC power source should conform to the conditions of Table 2-2 and 2-3.
An AC/DC power source that does not conform to the conditions may damage the analyzer.
3. About AC/DC adapter:
A08364 ai a dedicated AC/DC adapter only for this analyzer. Donot use A08364 for other use.
In the event of trouble of AC/DC adapter, please contact the sales and support offices.
4. Protection circuit:
When the over input voltage more than 16V or low input voltage less than 10V is input, the power supply is switched off by the protection circuit in the analyzer automatically. Reduce the input voltage to zero, if the power supply is switched off.
Wait 5 seconds when the power supply of the analyzer is switched off using by AC/DC adapter for the power supply turning on again.

2.5.2 Using Battery

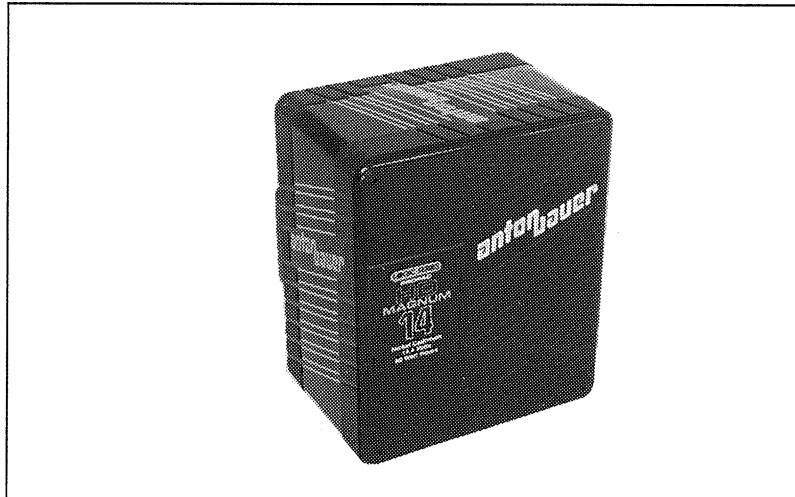

Figure 2-3 Battery pack

The battery pack recommended by Advantest operates approximately one and half hour continuously after the charge. The battery is installed into battery mounter of back panel on the analyzer (see "4.1 Initial Power on"). For information about recharging the battery pack please see the instructions that accompanied the battery.

CAUTION

When OPT20 is installed in the spectrum analyzer, the power is consumed even when the instrument power is turned off because the oven for the reference oscillator continues to function. Remove the battery from the spectrum analyzer before it is stored.

2.5.3 Using the AC/DC Adapter

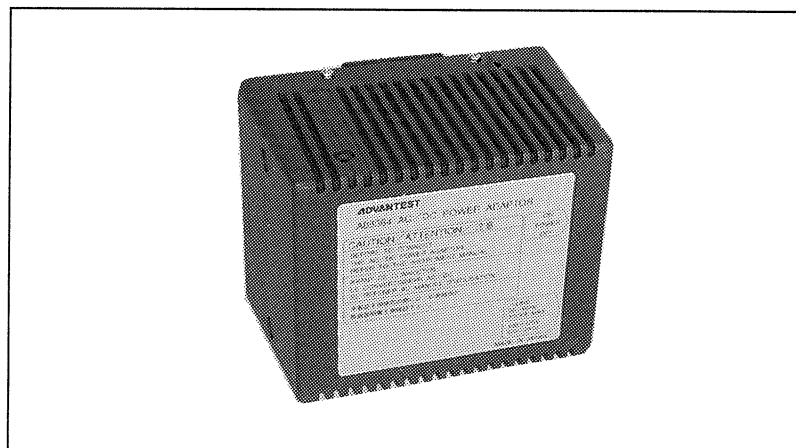

Figure 2-4 AC/DC adapter (A08364)

(1) Power supply conditions

For AC operation, use the AC/DC adapter supplied with ADVANTEST.
Power supply requirements are shown in Table 2-2.

Table 2-2 AC power requirements

Power	Conditions
Input voltage	90V to 132V, 198V to 250V This input voltage is automatically changed between 100VAC system and 200VAC system.
Frequency	48 Hz to 66 Hz
Power Consumption	100 VA or less

(2) Connecting the AC/DC adapter to the analyzer

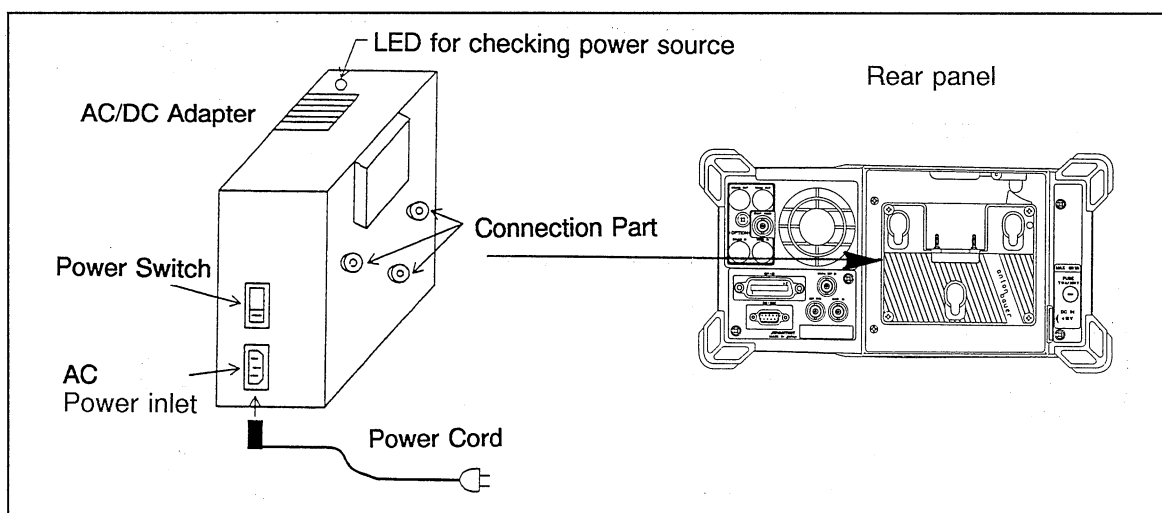

Figure 2-5 AC/DC adapter and battery connection diagram

- ① Attach the connection side of the AC/DC adapter to the battery mounter position of the rear panel. Push the AC/DC adapter in and down. The attachment is completed by hearing a "click" sound.
- ② Plug the power cord into the AC power inlet of the AC/DC adapter for connecting to the AC line.
- ③ Turn on the power supply switch of the AC/DC adapter. The LED for checking power source on the upper adapter is lit.
- ④ When removing the AC/DC adapter, turn off the power supply of the analyzer and the AC/DC adapter, and lift up the detachment lever on the upper panel on the unit backward and then detach the AC/DC adapter.

CAUTION

Failure in the AC/DC adapter.

The over current protective circuit is provided inside this analyzer to prevent the AC/DC adapter fuse from becoming burnt.

When a burnt fuse or abnormal conditions are encountered on this unit, contact a sales representative for requesting servicing. The address and the phone number are listed at the end of this manual.

WARNING

Do not connect the AC/DC adapter directly to the battery charger to prevent accidental damage to the AC/DC adapter.

Never connect the battery charger to the AC/DC adapter.

(3) Power plug cables

ADVANTEST provides the power cables for each country. (See yellow page of "Table of Power Options" at this manual.)

2.5.4 Using DC Power Supply

(1) DC power supply requirements

The DC power supply can be operated by using the external DC power cable A01434 (option).

The operation requirements for the unit is shown in Table 2-3.

Table 2-3 Analyzer DC power requirements

DC power	Conditions
Input voltage	10 V to 16 V
Power consumption	60 W or less

(2) Connecting a DC supply to the analyzer

CAUTION

1. When attaching to the Supply, be sure that the Positive terminal is connected to the RED lead, and the Ground terminal is connected to the WHITE lead. Reversed polarity cause result in damage to the analyzer.

2. Make sure that the POWER switch of the analyzer is OFF when removing the external DC power cable.

**SPECTRUM ANALYZER
OPERATION MANUAL**

2.5 Before Turning the Power On

Connect the external DC power cable to the DC power input connector located on the bottom right of the analyzer's rear panel. When removing the cable, turn off the power supply and detach the cable, while pushing the button on the connector of the cable.

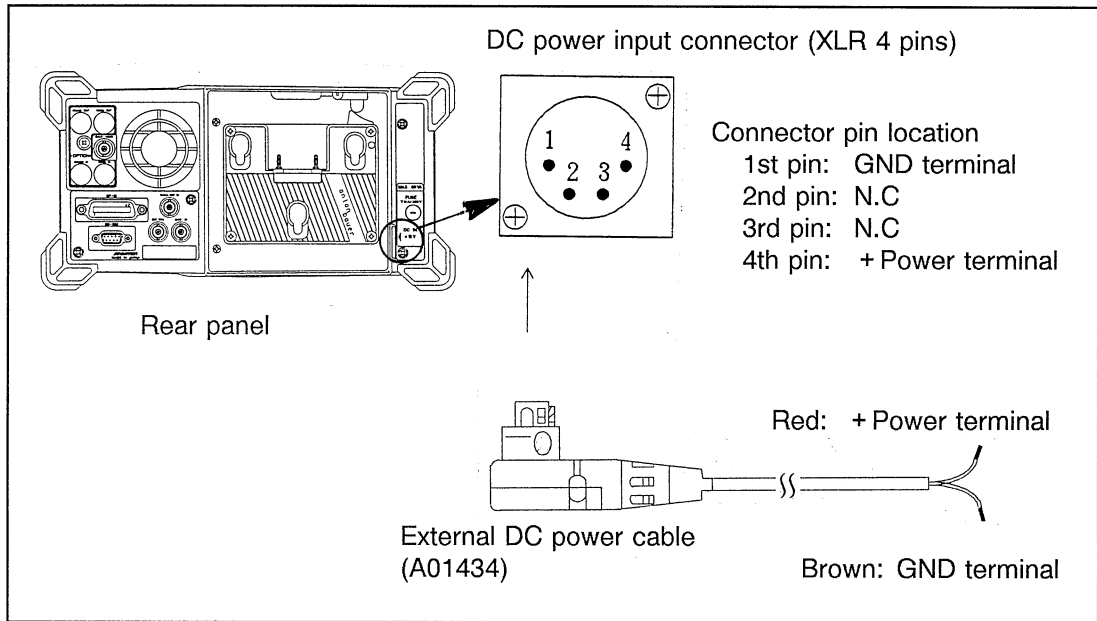

Figure 2-6 DC power supply connection diagram

(3) Checking the fuse

This analyzer uses time-lag type 10A/250V fuse for the DC power line. (The model of the fuse is 326010.)

The fuse is in a fuse holder located at the lower right of the analyzer rear panel. It can be removed by using a flat blade to turn the holder counterclockwise. When reinstalling the fuse, be sure to turn the holder clockwise until it locks into position.

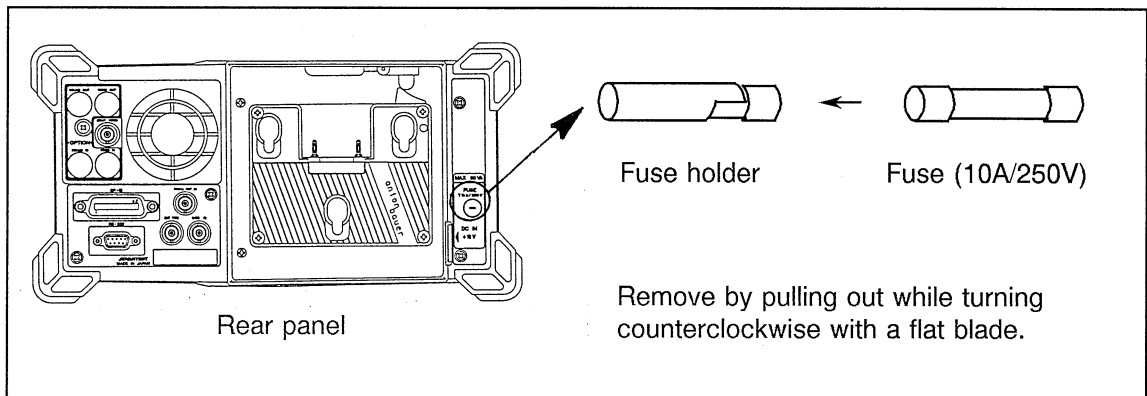

Figure 2-7 Checking the fuse

2.6 After the Power-on

Wait 30 minutes to allow the analyzer to warm up.

To increase the measurement accuracy, execute calibration.

(For the method of calibration, refer to Section 7.10.)

3. PANELS

This chapter briefly describes the analyzer's front, rear and top panels.

3.1 Front Panel

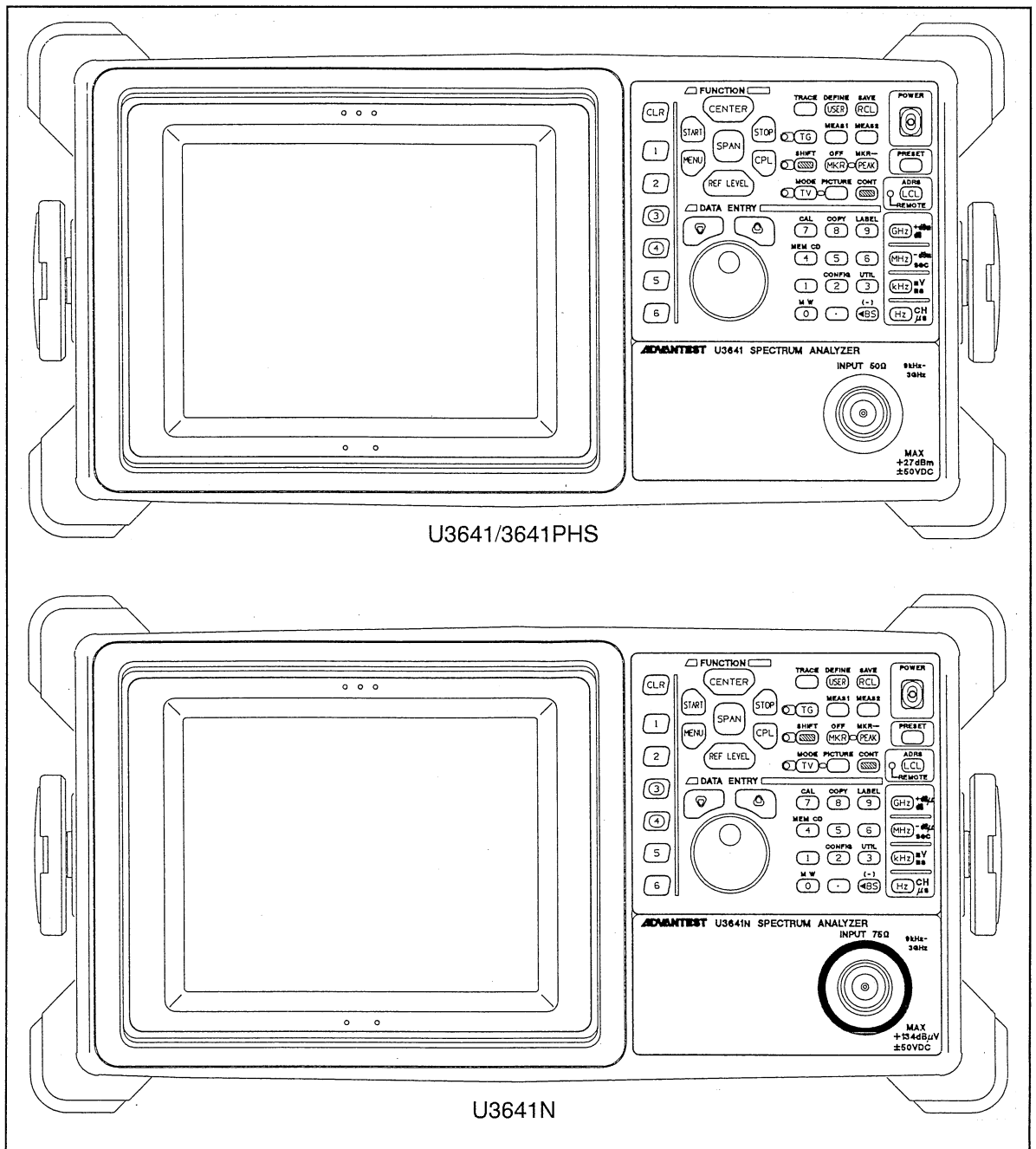
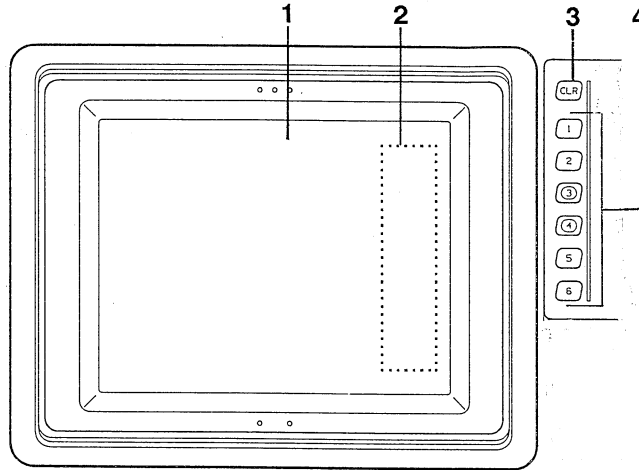

Figure 3-1 Front panel

**SPECTRUM ANALYZER
OPERATION MANUAL**

3.1 Front Panel

- Display and softkey Section



No.	Name	Function	Section
1	LCD display	Displays the waveforms and data in color. Also, the display frame can be moved.	
2	Softkey menu display area	Up to 6 software defined keys can be displayed here.	5.1
3	CLR key SHIFT + CLR key	Clears or displays the Softkey menu display. Turns off the back light of the screen.	5.1
4	Softkeys	6 keys, the function of each labeled by the corresponding softkey menu item.	5.1

- Input section

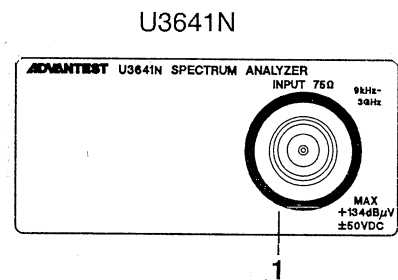
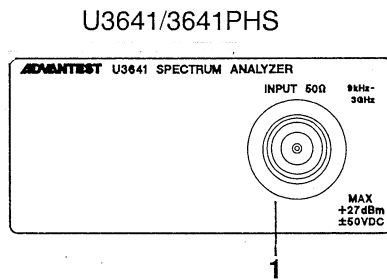

No.	Name	Function	Section
1	INPUT connector	50Ω connector for the U3641 and U3641PHS. 75Ω connector for the U3641N. (Both connectors are N type). Frequency range: 9 kHz to 3.0 GHz Input level: +27dBm, ±50VDC max(U3641/3641PHS) 134dB μ V, ±50VDC max(U3641N)	6.1

**SPECTRUM ANALYZER
OPERATION MANUAL**

- Power switch

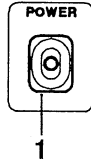

No.	Name	Function	Section
1	POWER switch	Turn the power on/off	4.1

- Function section

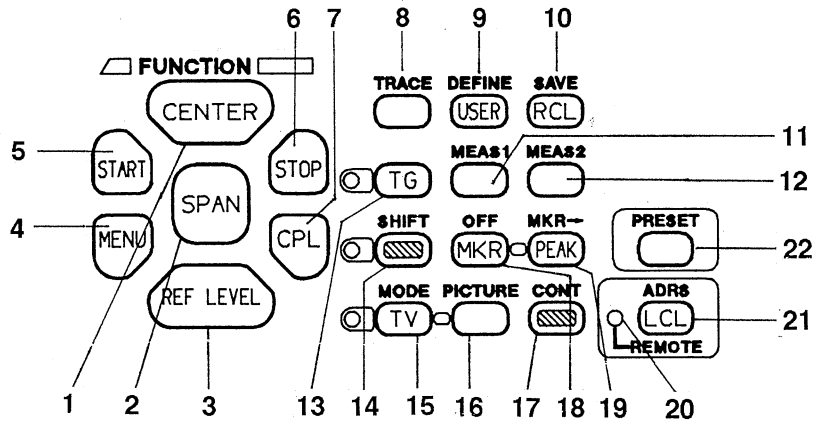

No.	Name	Function	Section
1	CENTER key	Selects the center frequency input mode.	7.1.1
2	SPAN key	Selects the frequency span input mode.	7.1.2
3	REF LEVEL key	Selects the reference level input mode.	7.1.4
4	MENU key	Selects menus for setting trigger, video detector, sweep, sound, and color modes.	7.1.6
5	START key	Selects the sweep starting frequency.	7.1.3
6	STOP key	Selects the sweep ending frequency.	7.1.3
7	CPL key	Setup the coupled functions: resolution bandwidth, video bandwidth, sweep time and attenuator.	7.1.5
8	TRACE key	Controls the display waveform (trace).	7.2
9	USER key DEFINE key (SHIFT + USER key)	Calls up an user defined function. Enter an user defined function.	7.5

**SPECTRUM ANALYZER
OPERATION MANUAL**

3.1 Front Panel

(cont'd)

No.	Name	Function	Section
10	RCL key	Recall a setup mode and waveform stored in a memory card.	7.6
	SAVE key (SHIFT + RCL key)	Store the current setup and waveform data to a memory card.	
11	MEAS1 key	Selects the ON/OFF of the incorporated preamplifier and the counter function.	7.4
12	MEAS2 key	Selects AM modulation measurement, dB down or third order mutual modulation distortion measurement.	7.4
13	TG key	When it is pressed, LED lights up on it and TG starts.	
14	SHIFT key	Selects the shift-mode (Multiple function keys). LED lights when the shift-mode is selected.	5.1
15	TV key (PHS key *1)	Enters TV mode to enable channel setup.	9.1
	SHIFT + TV key	Assigns channel table.	9.2
16	PICTURE key (AUTO key *2)	The spectrum screen can be changed to TV screen.	8.2
	SHIFT + PICTURE key	Displays the menu for TV monitor screen adjustment.	8.3
17	CONT key	No function	
18	MKR key	Displays the marker on the screen. Hides the marker.	7.3
	OFF key (SHIFT + MKR key)		
19	PEAK key	Moves the marker to the peak level of the displayed waveform.	7.3
	MKR → key (SHIFT + PEAK key)	Moves current marker point values to another function data (such as center frequency etc.)	
20	REMOTE lamp	Lights when the analyzer is being remotely controlled.	
21	LCL key	Goes to local control from remote control.	
	ADRS key (SHIFT + LCL key)	Sets the GPIB device address.	
22	PRESET key	Resets the screen setting to the initial condition.	7.7

*1 About U3641PHS, TV key becomes PHS key.
PHS key : Enters into PHS-ID demodulation mode (hereafter PHS mode). In the PHS mode, soft menu of PHS mode is displayed.
In the PHS mode selected, LED lamp lights up.

*2 About U3641PHS, PICTURE key becomes AUTO key.
AUTO key : The measurement is performed under the specified conditions and the measured results are stored in the memory card.

**SPECTRUM ANALYZER
OPERATION MANUAL**

3.1 Front Panel

• DATA ENTRY Section

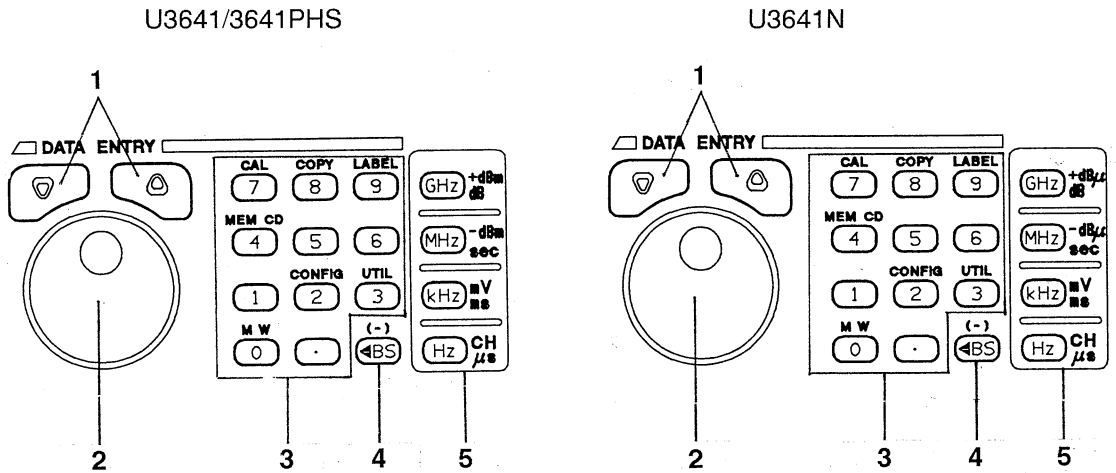

No.	Name	Function	Section
1	key (step key)	Increment or decrement input data.	5.1
2	(data knob)	Dial to fine adjust input data.	5.1
3	NUMERIC key pad (Extended function keys)	Input digits from 0 to 9, and decimal point. Used in combination with the shift key for extended functions.	5.1
	MW key (SHIFT + 0 key)	Set up a measurement window.	7.14
	CONFIG key (SHIFT + 2 key)	Executes the configuration function.	7.8
	UTIL key (SHIFT + 3 key)	Executes the utility function.	7.12
	MEM CD key (SHIFT + 4 key)	Operate the memory cards.	7.6
	CAL key (SHIFT + 7 key)	Calibrate the analyzer.	7.10
	COPY key (SHIFT + 8 key)	Outputs the screen to a printer or plotter.	7.9
	LABEL key (SHIFT + 9 key)	Put a label on the display screen.	7.11
4	BS key	Backspaces to edit numeric entry.	5.1
5	Units keys	Select a set of units, and input corresponding values.	5.1
	GHz key	Inputs the unit of GHz, + dBm and dB.	
	MHz key	Inputs the unit of MHz, -dBm and sec.	
	kHz key	Inputs the unit of KHz, mV and msec.	
	Hz key	Inputs the unit of Hz, μsec and CH.	

3.2 Rear Panel

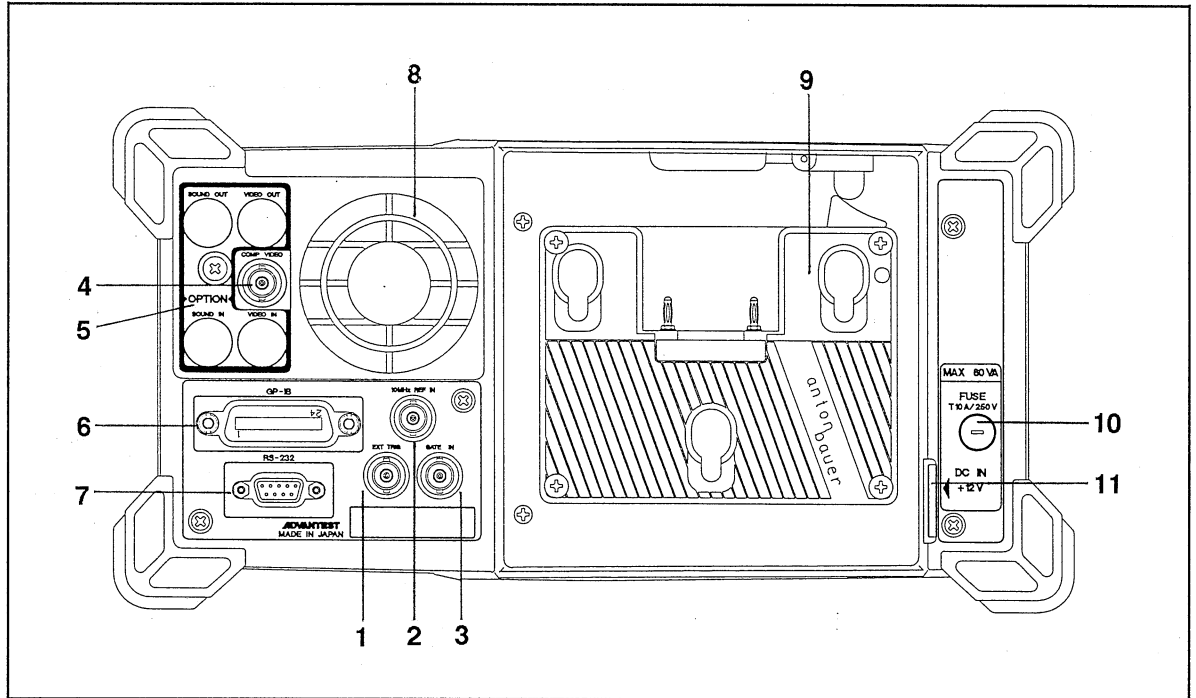

Figure 3-2 Rear Panel

**SPECTRUM ANALYZER
OPERATION MANUAL**

3.2 Rear Panel

No.	Name	Function	Section
1	EXT TRIG terminal	(External trigger input terminal) Approximately 10k Ω input impedance; starts sweeping at the leading/trailing edge (selectable) of TTL level input signal.	7.1.6
2	10 MHz REF IN terminal	Input Impedance : approx 500 Ω at 10MHz Input level range : 0 to +16dBm	7.8.5
3	GATE IN terminal	(External seep control terminal) TTL High level enables sweep and measurement. TTL Low level stops both.	
4	COMP VIDEO terminal	(Composite video output terminal) output amplitude : 1V p-p output impedance : approx. 75 Ω Based on NTSC standard.	5.2.3
5	Option terminal	Allows audio input/output, and video input/ output when Option 72 is installed.	
6	GPIB connector	GPIB connector for external control, or connection to printer/plotter.	Chapter 11
7	RS-232 connector	Connector for external controller which is used to execute remote control through an RS-232 interface.	5.4
8	Cooling fan	Exhausts heat outside the analyzer.	
9	Battery mount	Battery (Anton Bauer PROPAC14) or AC/DC Adapter (A08364) is mounted here.	2.4
10	FUSE	Fuse for the external DC power supply. (10A/250V)	2.4.4
11	DC IN connector	External DC power connects here via the external DC power cable (A01434). Input voltage range: +10V to +16V.	2.4.4

3.3 Top Panel

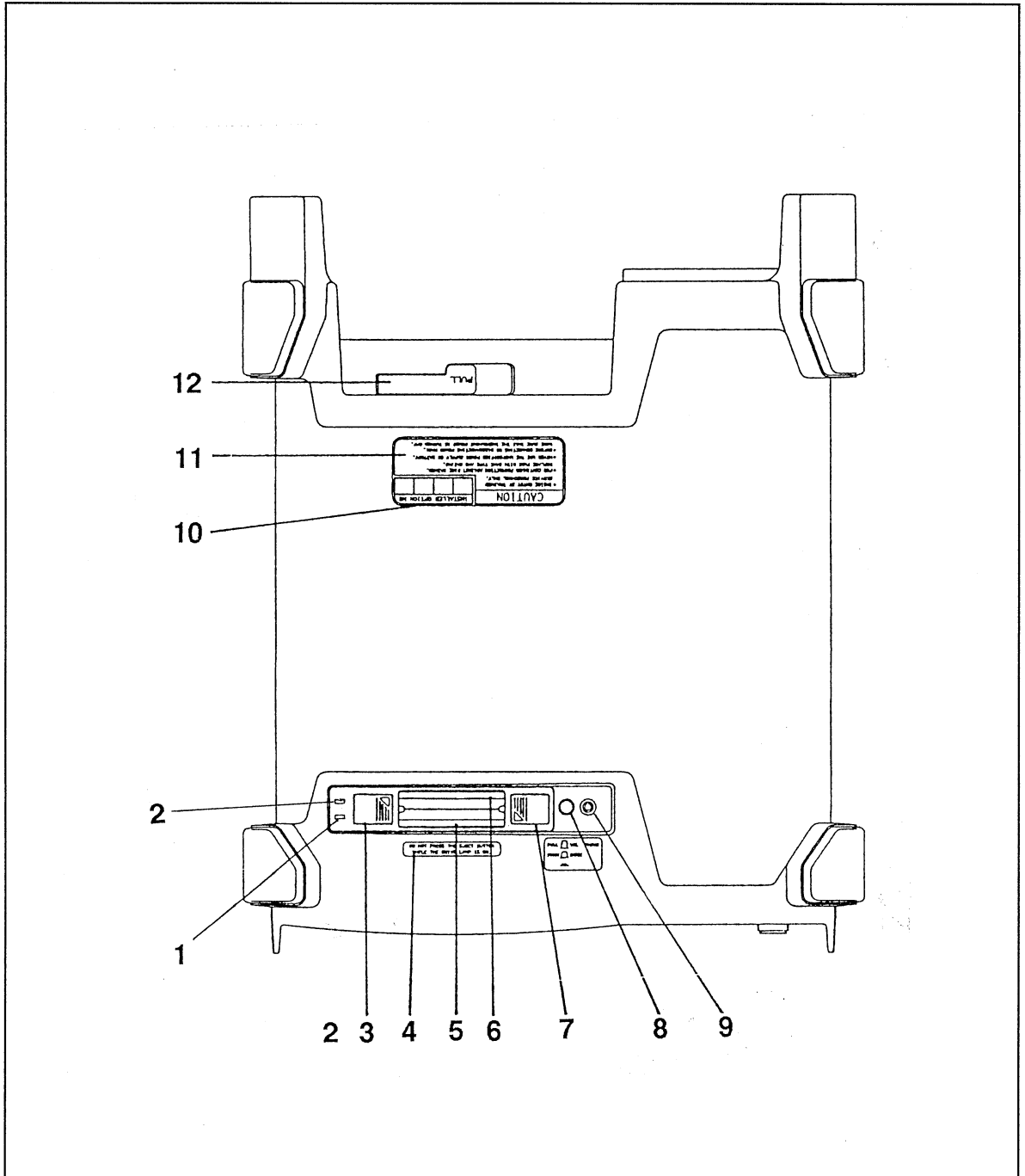

Figure 3-3 Top Panel

**SPECTRUM ANALYZER
OPERATION MANUAL**

3.3 Top Panel

No.	Name	Function	Section
1	Drive A indicator LEDs	Light Yellow when you install a memory card or red when you access or write data to a memory card.	5.3
2	Drive B indicator LEDs		
3	Eject button for Drive B	Eject memory card from Drive B.	
4	Caution Label	<p>The following message is shown :</p> <div style="border: 1px solid black; padding: 10px; text-align: center;"> <p>CAUTION</p> <p>DO NOT PRESS THE EJECT BUTTON WHILE THE DRIVE LAMP IS RED LIGHT.</p> </div>	5.3
5	Memory card slot for Drive A	Accepts memory card for Drive A.	
6	Memory card slot for Drive B	Accepts memory card for Drive B.	
7	Eject button for Drive A	Ejects memory card from Drive A.	
8	Volume and Intensity knob	This is a two-step-pop-up knob. When it is pressed in a lowest position, it pops up and gets available for screen intensity adjustment. Further it gets available for AM/FM demodulation audio output adjustment when it is pulled in the position where it has popped up. When not changing the screen intensity and the audio output, put it into the panel.	7.1.6
9	Ear phone terminal	8Ω ear phone terminal of AM/FM detected Audio output.	
10	Option list	Options numbers are listed here.	

**SPECTRUM ANALYZER
OPERATION MANUAL**

3.3 Top Panel

No.	Name	Function	Section
11	Caution Label	<p>The following message is shown :</p> <div style="border: 1px solid black; padding: 5px; margin: 5px 0;"> <p style="text-align: center;">———— CAUTION ————</p> <p>INSIDE ENTRY BY TRAINED SERVICE PERSONNEL ONLY.</p> </div> <div style="border: 1px solid black; padding: 5px; margin: 5px 0;"> <p>FOR CONTINUED PROTECTION AGAINST FIRE HAZARD, REPLACE FUSE WITH SAME TYPE AND RATING.</p> </div> <div style="border: 1px solid black; padding: 5px; margin: 5px 0;"> <p>NEVER USE THE UNSPECIFIED POWER SUPPLY OR BATTERY.</p> </div> <div style="border: 1px solid black; padding: 5px; margin: 5px 0;"> <p>BEFORE CONNECTING OR DISCONNECTING POWER PACK, MAKE SURE THAT THE INSTRUMENT POWER IS TURNED OFF.</p> </div>	
12	Battery or AC/DC adapter detachment lever	Releases the catch on the battery or AC/DC adapter so that it can be removed from the adapter.	2.4

4. EASY USE INSTRUCTIONS

This chapter provides easy directions from initial power-up through measurement completion for beginners users.

4.1 Initial Power-up

Three different power supply options are available for this analyzer: battery, AC or DC supply. This section explains the case of using battery first.

(1) Installing the battery

Begin by Attache a fully charged battery (PROPAC14) to the rear of the analyzer.

- ① Align the three prongs on the battery with the corresponding female connection points on the rear of the analyzer.

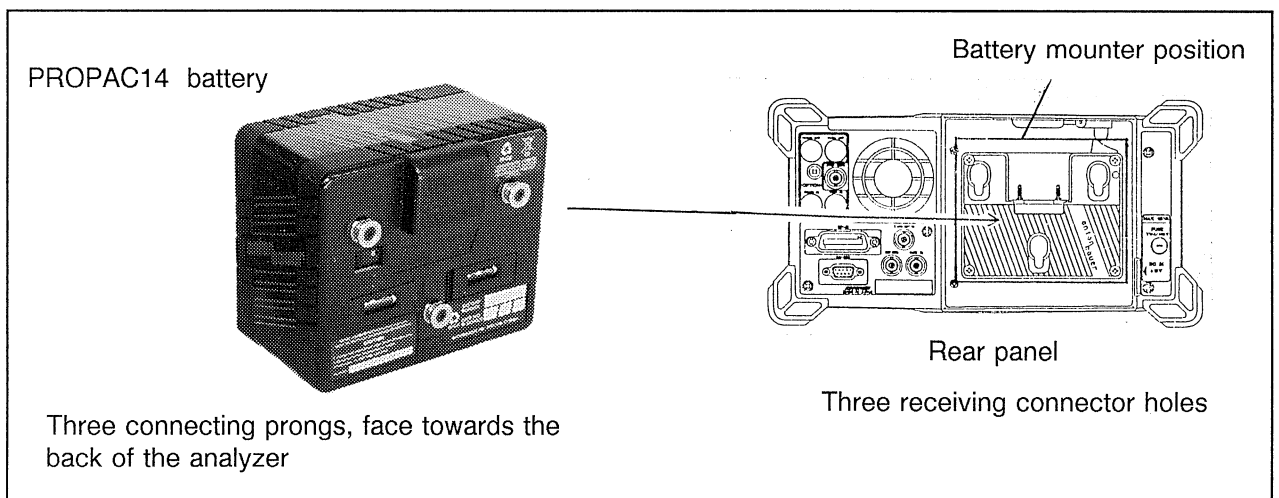

Figure 4-1 Battery connection

- ② Push the battery in and down to complete the electrical connection and mechanical latch. You should hear a "click" sound as the battery locks into place.

Note: The AC/DC Adapter connection is similar to the battery. See section "2.4 Before turning the power on" for details on power supplies.

(2) Turning on the power

Now that the battery is in place, the front panel power switch can be used to turn the analyzer on.

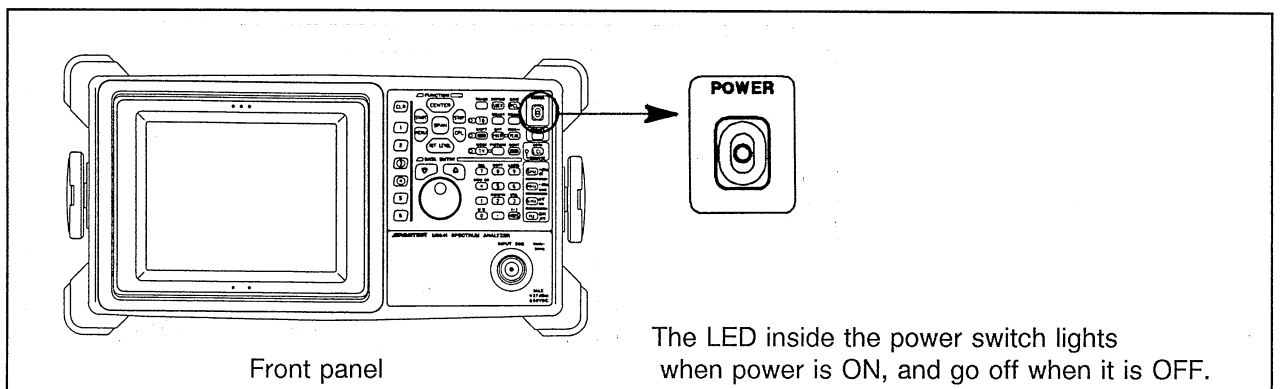
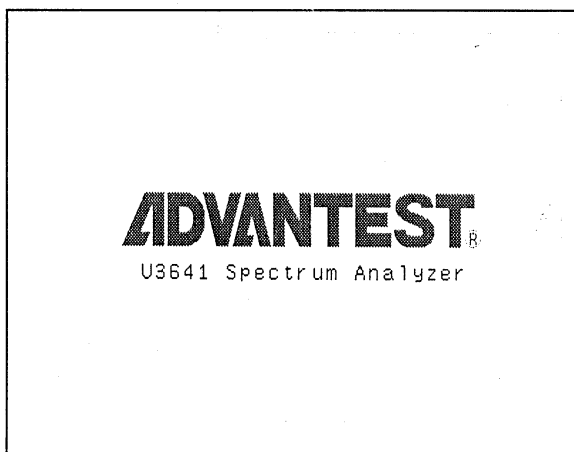

Figure 4-2 Power ON/OFF

After you turn the power on, the following screen appears before entering the initial operational mode.



"ADVANTEST" appears in the center of the display. (The analyzer is doing a self-check while this screen appears.)



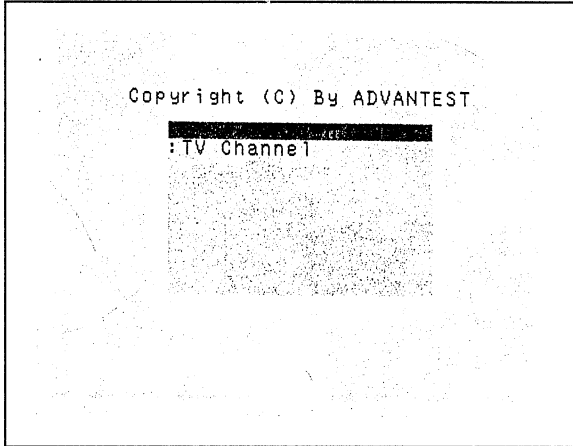

A list of the installed options appears.

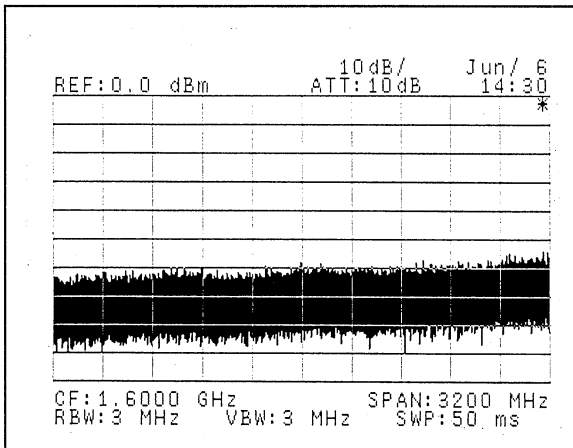

When the analyzer is turned on first, after factory shipment, display appears.

In normal operation, the analyzer will return to the settings current when it was last turned off, and the display will be modified accordingly.

PRESET

The can be used at any time to return to the factory configuration.

Display in the initial factory ship setup (U3641)

4.2 From starting Measurement to Finishing it

The analyzer is now ready for us to start making some measurements. Let's get started to analyzes the spectrum of a 500 MHz, -20 dBm signal.

(1) Setting for measurement

- ① Prepare a standard signal generator to generate the frequency of 500 MHz and -20 dBm signal.
- ② Adjust the signal generator to 500 MHz and -20 dBm output.
- ③ Connect the RF Output of the signal generator to the analyzer RF INPUT with a BNC - BNC cable.

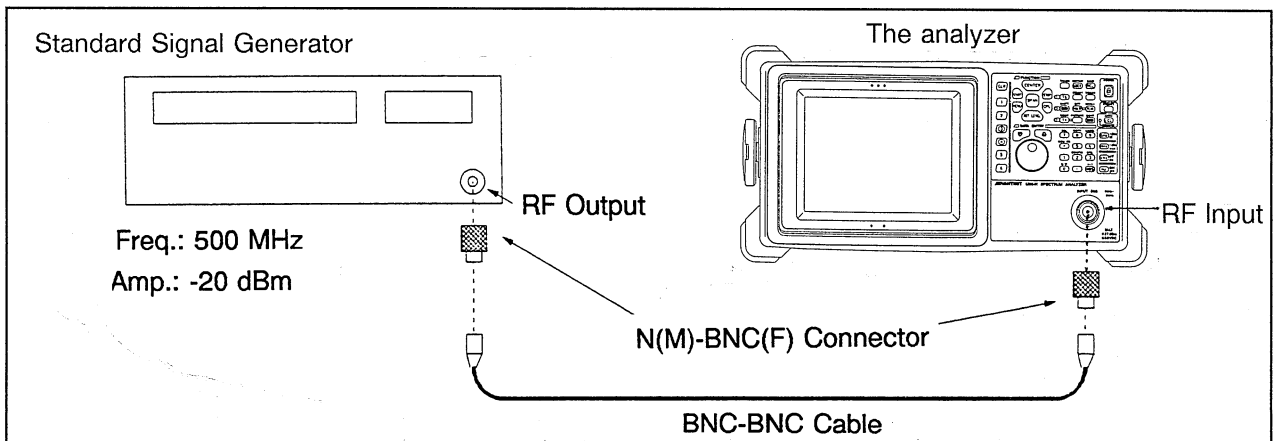
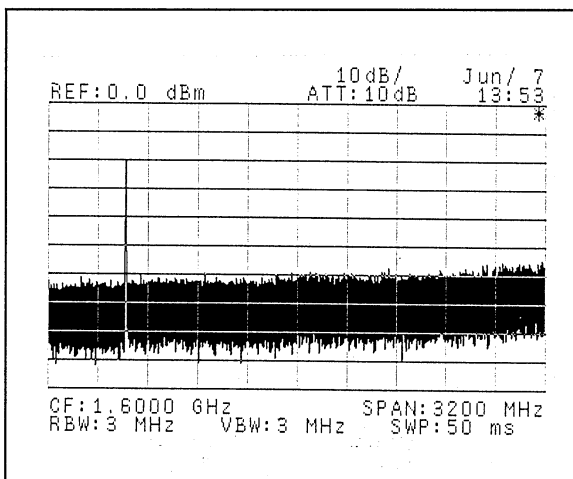

Figure 4-3 Measurement setup

(2) Measurement Begins



When the above setup is complete a spectrum as shown in the left appears picture.

(3) Preliminary information about the analyzer operation

The analyzer is operated with Panel Keys and Soft Keys.

Whenever a Panel Key is pressed a corresponding softkey menu is displayed at the right side of the screen.

Pressing a soft key corresponding to the softkey menu executes the function.

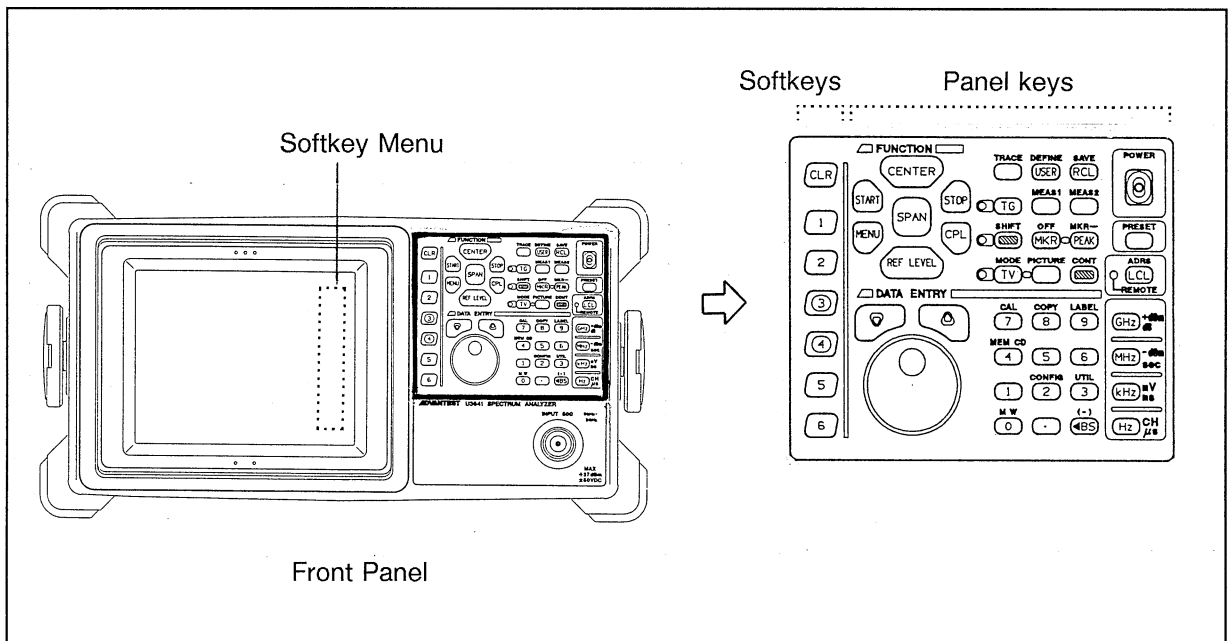
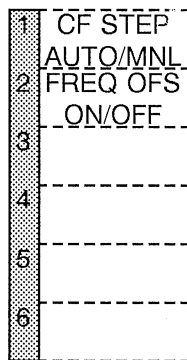



Figure 4-4 Panel keys and softkeys

① Panel keys and softkeys

For example, try pressing  which sets a center frequency.

The softkey menu is displayed as follows:



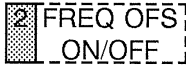

There are two items,  and , and four blank items in the softkey menu.



When pressing the softkey corresponding to , the color of AUTO/MNL changes.

In this case, a color-changed menu is activated.

② Function of the SHIFT key

To execute blue-colored functions above panel keys, press  and then each key.

When pressing , the left LED lights up.

Example: To execute MKR-function, press  and then .

③ Data input

When data is set by pressing a softkey and panel keys, a selected function label and its setting value is displayed at the top left of the screen. This display area is called “active display area” and helps input data.

Figure 4-5 explains how to read the screen displayed.

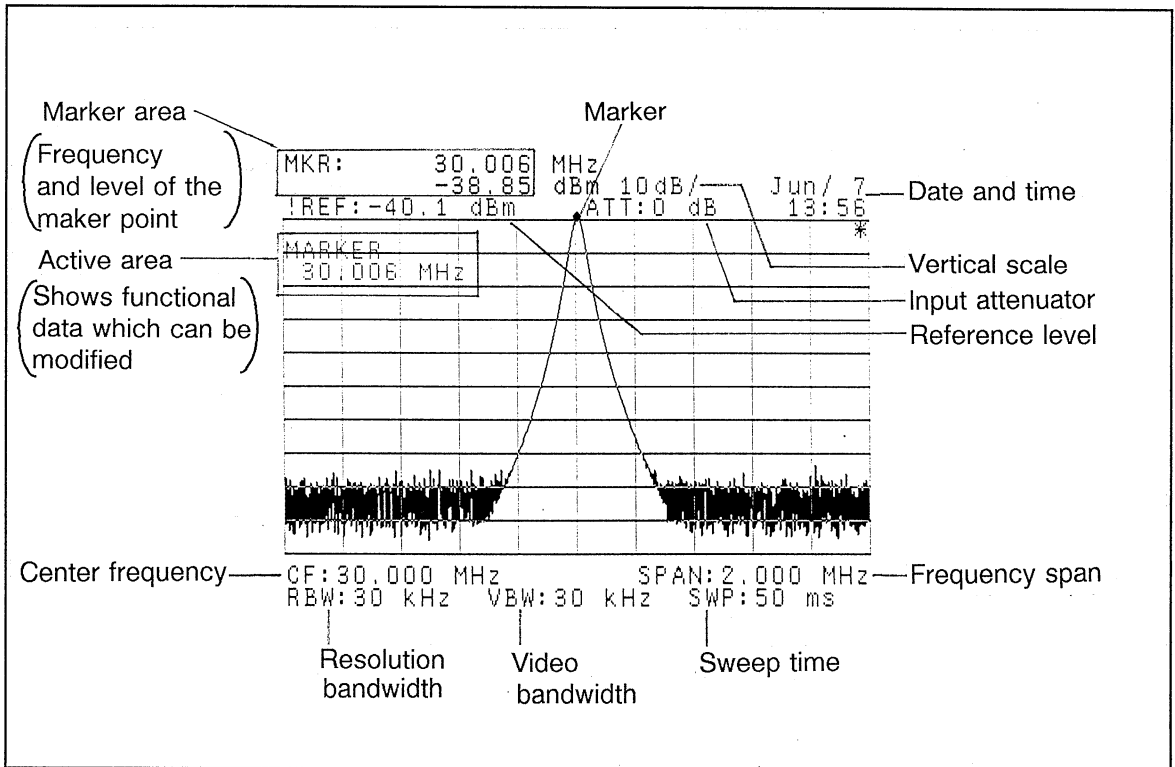

Figure 4-5 Details on Screen Display

There are three different methods for data input.

1. Step keys : Data is incremented or decremented by the "step size".
2. Data knob : Continously changes a setting value under display resolution.
3. Numeric keys and Unit keys : Data is set by numeric value entry.

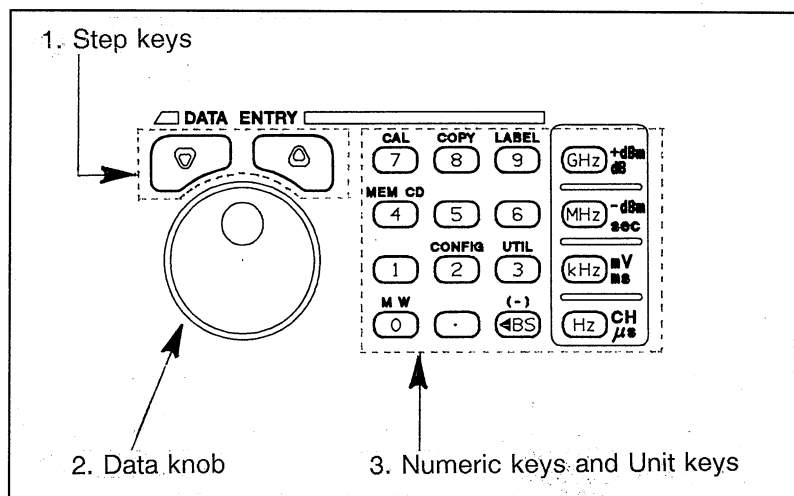
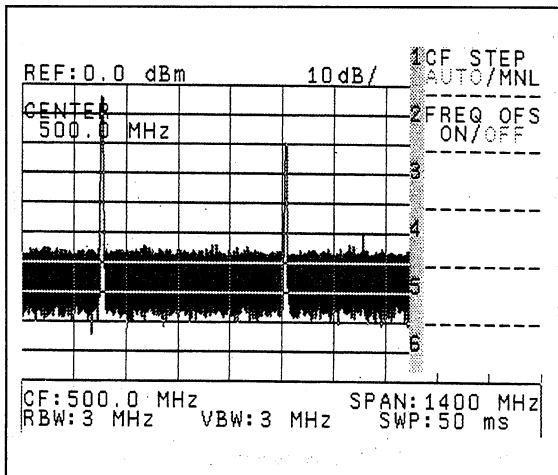

Figure 4-6 Data input



(4) Setting the center frequency

Set the center frequency with the following key pushes:



The signal is displayed centrally on the screen.

Note: The step keys and the data knob can be also used instead of the numeric keys.

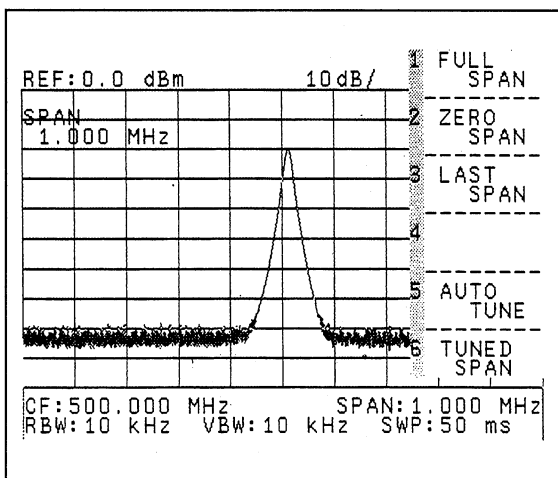

(5) Setting the frequency span

Let's set the frequency span to get a clearer display, say 1 MHz here.

Using the NUMERIC keys

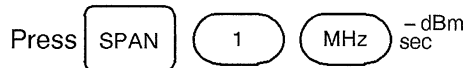

Using the STEP keys



as necessary (or hold it down) until the span reaches the desired value.

Note: The Data knob can be also used.

(6) Setting the reference level

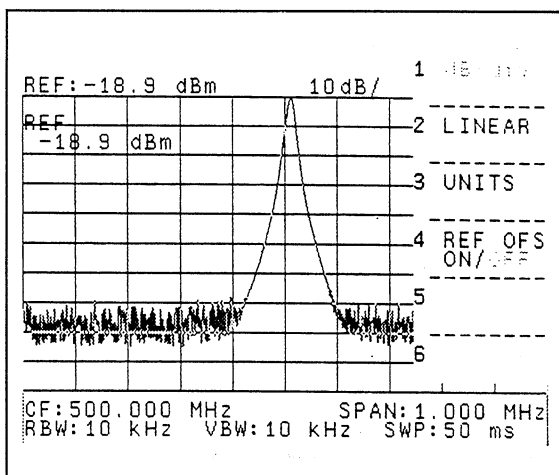

Now let's get our reference level setup, say to just about the peak spectrum level.

Using the Data Knob

Press **REF LEVEL**, and then turn the Knob while watching the display move to the desired level.

Using the MKR→REF key

An even quicker way is to use the MKR→REF (Move Marker to Reference) function.

Just press **MKR→** **PEAK** **MKR→REF** and the reference

level will be adjusted to be the peak level.

Note: The NUMERIC keys and the Step keys can be also used.

(7) Measuring the frequency and level

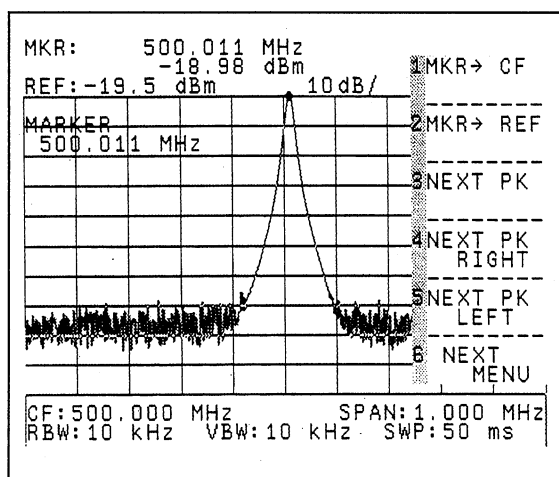

Measuring the frequency and level of the peak using

the marker. Just press **MKR→** **PEAK**.

The "active marker" symbol **◆** will appear at the highest point of the spectrum, and the numerical values for the frequency and level are shown at the top left of the display.

(8) Some handy functions: MKR→CF, MKR→REF

① The MKR→CF function

This function sets the center frequency to the frequency of the active marker point. This is especially useful when we want to center a peak (or other point) with an unknown frequency.

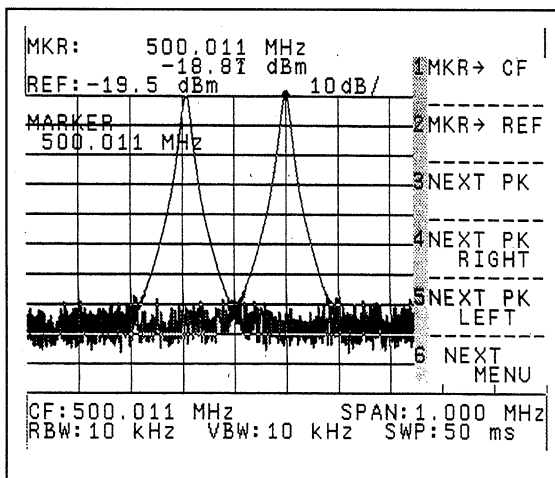

Spectral peak case

Key presses are:



A point not the peak level

Press the **OFF** **MKR**, and then move the marker to the point of interest by turning the data knob **○**. Then move the center frequency by pressing: **SHIFT** **MKR→** **PEAK**



② MKR→REF function

This function makes the level of the currently active marker be the reference level. Quite useful in setting the spectral peak to the reference.

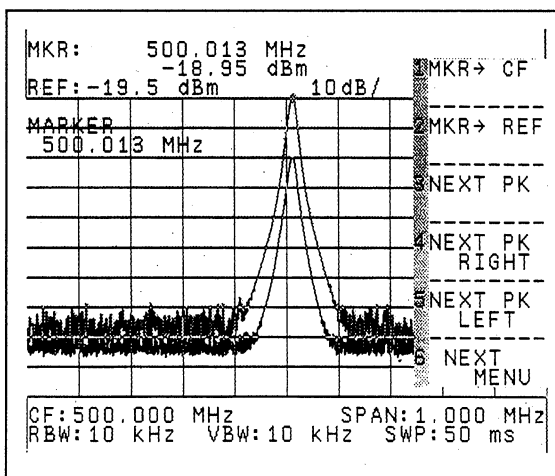

Peak to reference level case

Press:



Non-peak level to reference case

Press the **OFF** **MKR** to select the marker and then turn the data knob **○** to move it to the location of interest.

Then finish by press: **SHIFT** **MKR→** **PEAK** **MKR→REF**

5. METHOD OF OPERATION

This chapter explains basic operation, how to output screen data to an external device, how to use memory cards, and remote-control function using a RS232 interface.

5.1 Key description

The key configuration of the analyzer consists of three groups.

- Softkeys
- Function keys
- Data entry keys

5.1.1 Softkeys

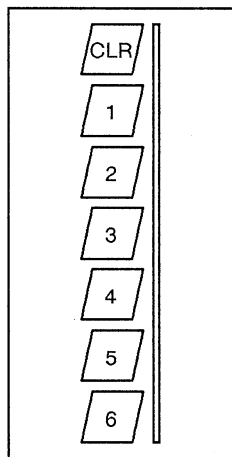

This group is composed of six softkeys which execute softkey menu functions and  key which erases and displays the softkey menu.

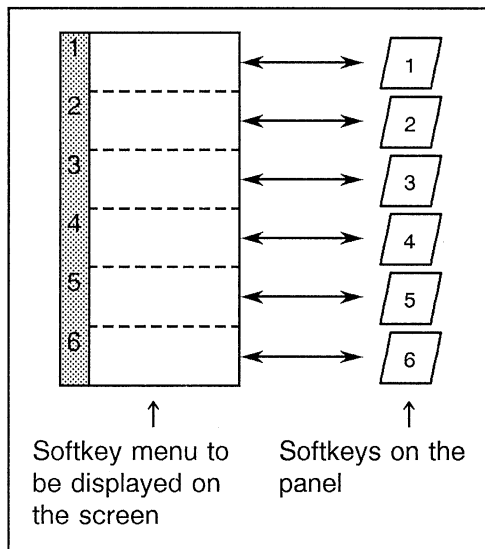

Six softkeys correspond to the number of the softkey menu and execute softkey menu functions displayed on the right side of the screen.

In , for example, AUTO or MNL is

selected. When pressing the softkey, the color of AUTO/MNL changes. When the color of MNL changes, MNL function is activated.





 shows that AUTO is activated.

Figure 5-1 Softkey menu and softkeys

- ② Clear key ()
 - When pressing the  key, the softkey menu of the screen is erased and then an asterisk (*) is displayed at the upper right of the screen. In this mode, basic functions are controlled by panel keys. (Refer to Chapter 7.)
 - When pressing  and then , the back light of the screen is turned off.

5.1.2 Function section

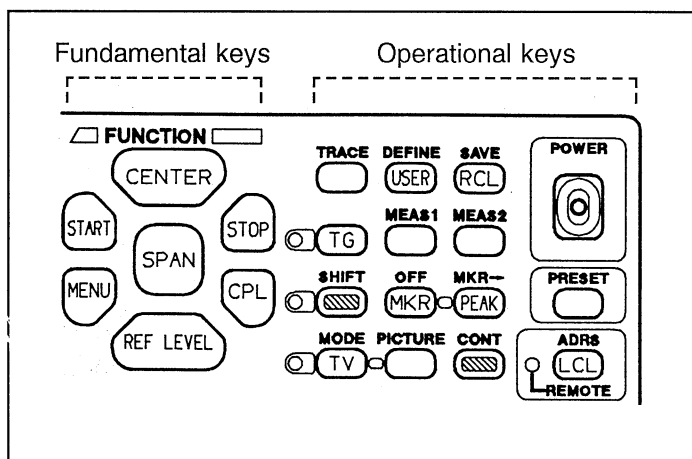

Figure 5-2 Panel keys in the function section

This section is composed of function keys.



① Fundamental keys

Seven keys shown on the left of Figure 5-2 are called "Fundamental keys." They are useful for basic setting of the analyzer.

② Operational keys

This group is shown on the right of Figure 5-2 and consists of 15 keys supporting power-up, marker control, reset, shift, save, and recall functions.

The SHIFT key is used to select blue-colored function printer above keys.

For example, to activate the  function, press  and then .

5.1.3 DATA ENTRY section

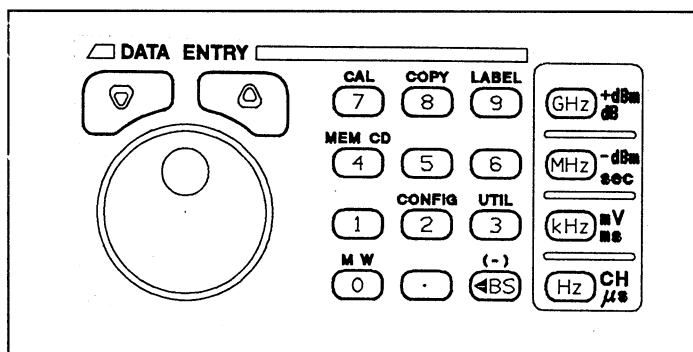

Figure 5-3 DATA ENTRY section part of the front panel

Data for analyzer setup is entered using these keys. There are three different ways of data input:



The up and down step keys are used to increment and decrement data values in steps of stepsize. Data can be set: the down key enables to decrement data values and the up key for increment.

In this manual the symbol above will be used for the step keys.



The data knob can be used to continuously change data values (in steps that can be resolved in the display). It is very useful in making fine adjustments to data values. In this manual the symbol above will be used for the data knob.

3. Numeric key pad and units keys

These keys can be used to directly input numerical values. When the number has been completely entered, pushing one of the unit keys will confirm the correct entry.

When used in combination with , the other functions above each numeric key can be executed.

Corrections can be made with the BS (backspace) key. Each press of BS deletes one

digit from an entry. Also, when data is not input, "-" is input by press .

5.2 Output to Screen Data

Screen data can be output to an external plotter, printer, memory card or video printer. The method of connecting and using each external unit is explained below.

5.2.1 Plotter Output

Measurement data from the analyzer can be output to a GPIB input plotter.

(1) Connection to the plotter

Table 5-1 gives a list of plotter models that can be used.

The GPIB cable connection is shown in Figure 5-4.

CAUTION

1. Be sure that the power is OFF before connecting the GPIB cable.
2. Please read the instruction manual for the plotter before you begin to use it.

Table 5-1 List of plotters that can be used with the analyzer

Manufacturer	Plotter model
ADVANTEST	R9833
Hewlett-Packard	HP7470A, HP7475A, HP7440A, HP7550A
Hitachi Electronics	682-XA

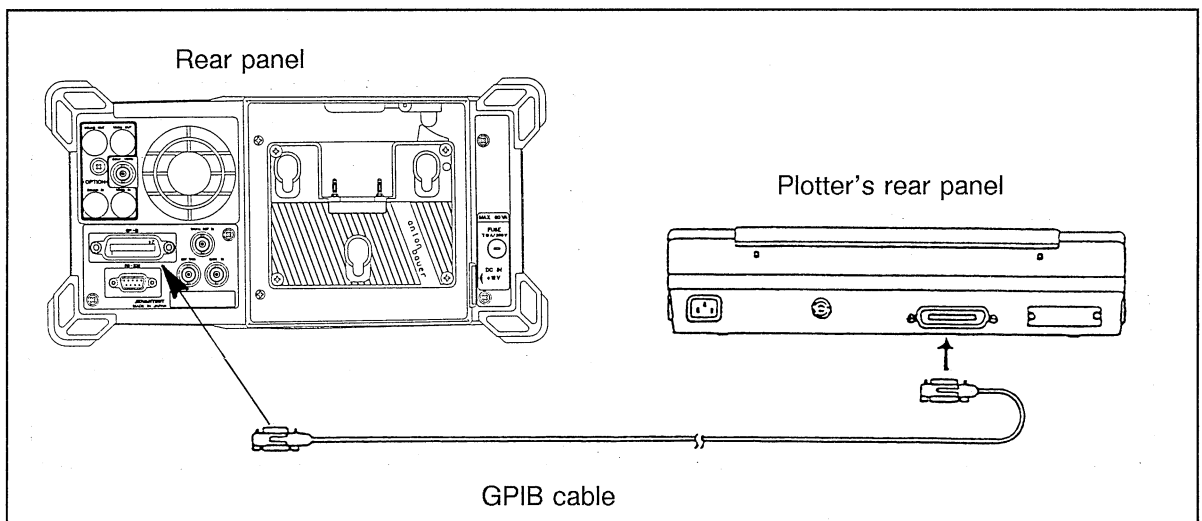

Figure 5-4 Plotter connection diagram (Example of the analyzer and R9833 connection)

(2) Plotter setup

The plotter GPIB address should be set to LISTEN ONLY, or to the same address (0 to 30) that the analyzer has been configured to use as its output device.

Depending on the plotter model there will be other things that need to be set up besides the address, please consult the plotter manual for the necessary details.

Figure 5-5 shows the set up for use with A4 size paper (on listen only mode) on R9833 (ADVANTEST product).

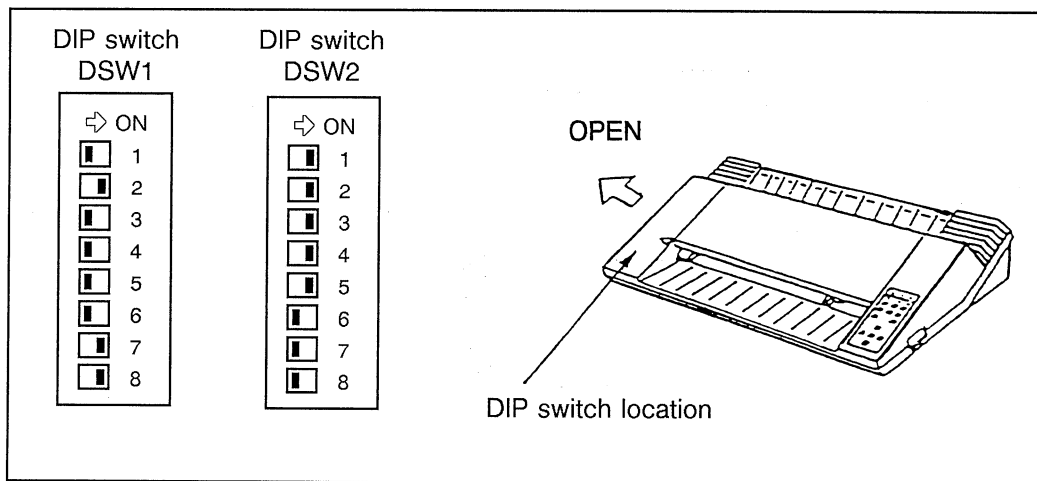

Figure 5-5 Plotter DIP switch settings

(3) Plotter output procedure

Output is directed to the plotter with the CONFIG key, and the COPY function does the actual output.

① PLOTTER output selection



When the plotter has been selected as the output devices where the screen data is sent.

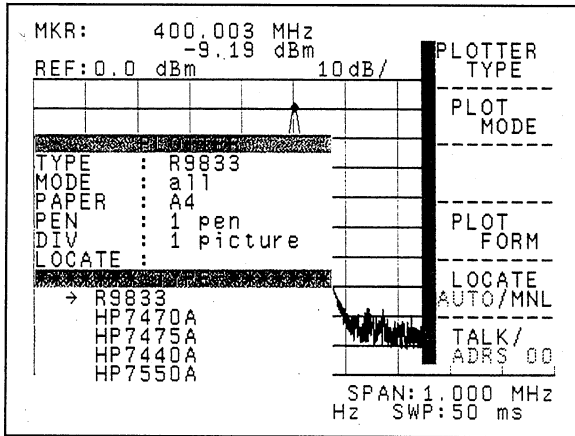

Figure 5-6 Plotter configuration window

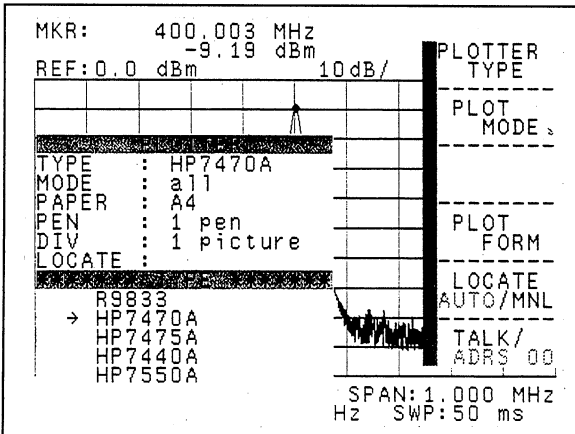

Figure 5-7 Plotter type selection

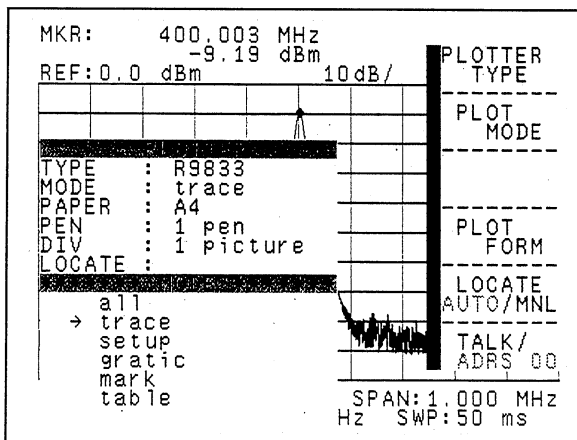

Figure 5-8 Plotter mode selection

② Plotter configuration window

Press and

the screen shown in Figure 5-6 will appear. The top of the display shows the currently selected configuration, the lower portion of the screen shows an item to be modified, marker with a → symbol.

③ Selecting a plotter to be used

Each press of cycles the → marker through the possible plotter types (see Table 5-1).

Note : Select plotter type "R9833" if you use a plotter "682-XA" provided by Hitachi Electronics Ltd.

④ Plot mode selection

Each press of cycles the → marker through the possible plot modes (see Table 5-2). Moreover, if table is selected, the type of the table data should be selected in the same manner as in step ⑤.

Table 5-2 Plot mode

Plot mode	Descriptions
all*	Outputs all display screen data.
trace	Outputs display waveform data (trace data) only.
set up*	Outputs setting condition only.
gratic	Outputs grid line on display screen only.
mark	Outputs marks only such as display line, limit line or marker.
table	Outputs table data such as antenna coefficient. Level comprised data or limit line shown in Table 5-3.

* : When all or setup is selected, the input label are automatically output.

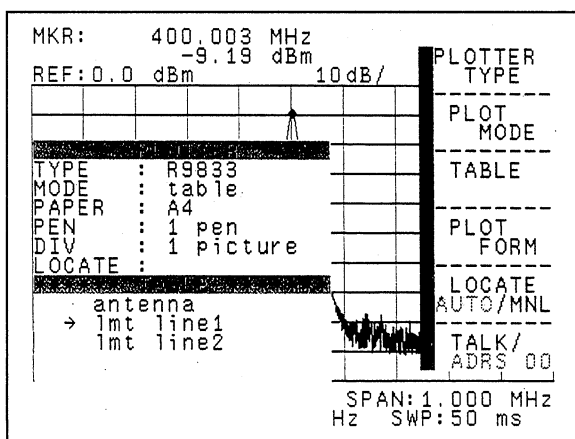



⑤ TABLE data type selection
This menu item only becomes active if the Plotter Mode has been set to be TABLE. Each press of  cycles the → marker through the possible data types (see Table 5-3). If necessary to escape from this menu push  to return to ④.

Figure 5-9 TABLE data type selection

Table 5-3 Table data

Table data	Descriptions
antenna	Antenna coefficient or level comprised data
lmt line 1	Table data on limit line 1
lmt line 2	Table data on limit line 2

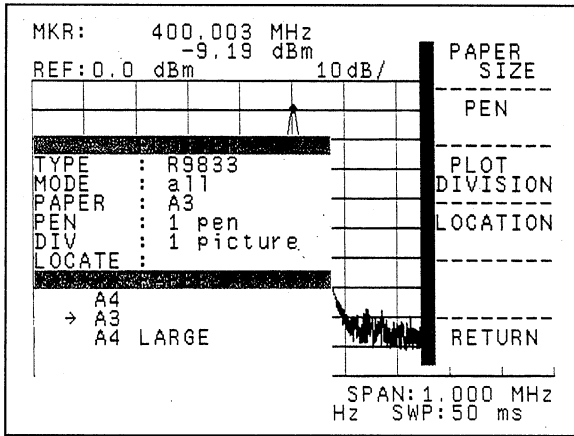

Figure 5-10 Paper size selection

⑥ Paper plot size selection

Press PLOT FORM PAPER SIZE

Each press of PAPER SIZE cycles the → marker through the possible plot sizes.

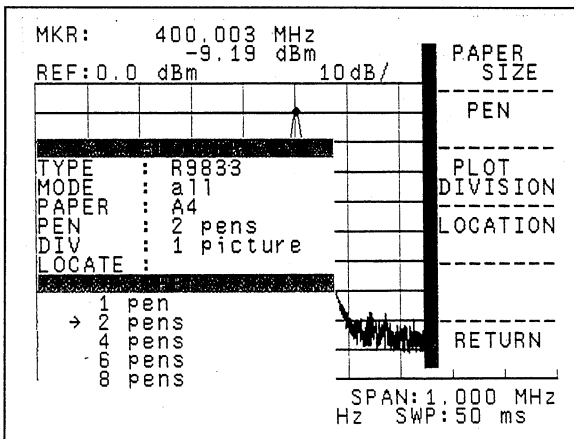

Figure 5-11 Pen count selection

⑦ Pen count selection

Press PLOT FORM PEN

Each press of PEN cycles the → marker through the possible pen number (see Table 5-4).

Table 5-4 Plotter pen assignments

1 Pen	Pen 1	Frame, Marker, Window, Limit line, Alphanumeric characters, Display line, Waveform A, Waveform B
2 Pens	Pen 1 Pen 2	Frame, Marker, Window, Limit line, Waveform B Waveform A, Alphanumeric characters, Display line
4 Pens	Pen 1 Pen 2 Pen 3 Pen 4	Frame Display line, Marker, Window, Limit line Alphanumeric characters Waveform A Waveform B
6 Pens	Pen 1 Pen 2 Pen 3 Pen 4 Pen 5 Pen 6	Frame. Marker, Alphanumeric characters Waveform A Waveform B Display line Window, Limit line
8 Pens	Pen 1 Pen 2 Pen 3 Pen 4 Pen 5 Pen 6 Pen 7 Pen 8	Frame Marker, Alphanumeric characters Waveform A Waveform B Display line Window Limit line

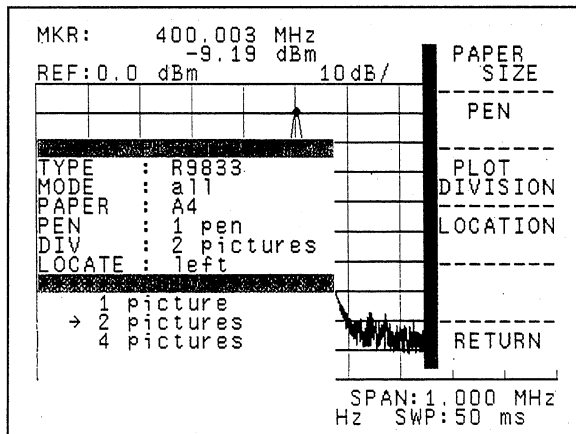

Ⓢ Display division selection

Press **4** **PLÖT FORM** **3** **PLÖT DIVISION** in order.

Each press of **3** **PLÖT DIVISION** cycles the → marker through the possible division size for output screen.

Figure 5-12 Display division selection

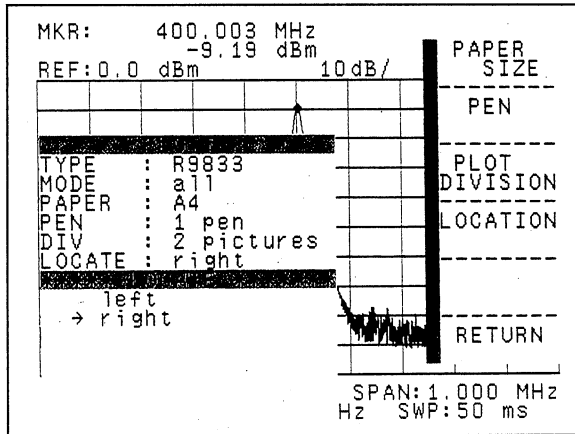

Figure 5-13 Output location selection
(two pictures case)

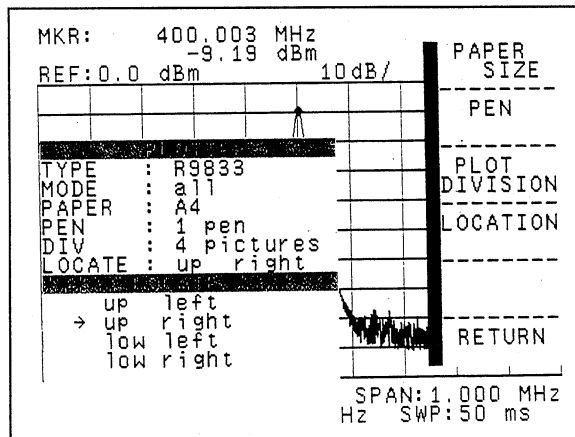

Figure 5-14 Output location selection
(four pictures case)

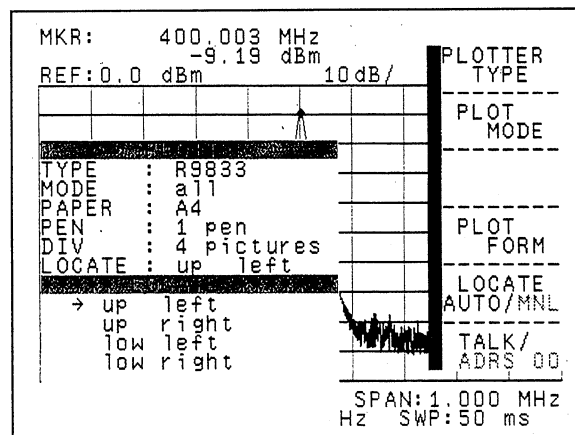

Figure 5-15 Switching the output location
between AUTO and MANUAL

⑨ Output location selection

After the Display Division selection has been set to two or four pictures,

press **4** **PLOT FORM** **4** **LOCATION** in order.

Each press of **4** **LOCATION** cycles the → marker through the possible output locations.

- When the Display division selection is set two pictures in ⑨. Select the output location from two positions of right and left (See Figure 5-13).

- When the Display division Selection is set four pictures were chosen in ⑨. Select the output location from four positions of upper left, lower left, upper right and lower right (See Figure 5-14).

⑩ Output location AUTO/MANUAL selection

Select the output locations when the division output is set.

Select the output location with **5** **LOCATE** **AUTO/MNL**.

When the AUTO is set, the screen is automatically set from the former output position. When the MNL is set, the position to be output can be set.

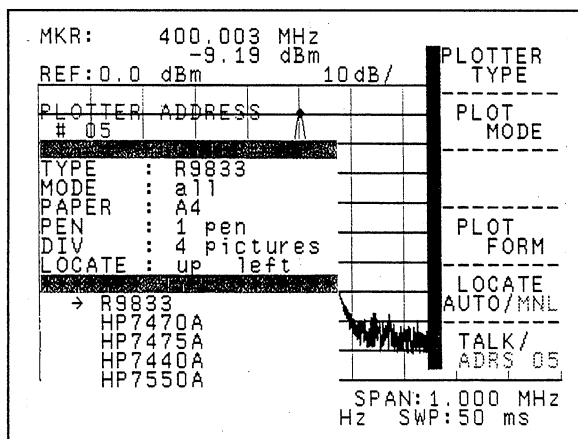

Figure 5-16 Talk only / address

① GPIB addressing mode, address setup

Select the addressing mode with TALK / ADRS_01

When TALK appears in reverse video the analyzer is setup to be a GPIB talk only device. When ADRS 01 is active, the address of the output device must

be entered. Use the numeric key, step keys or data knob to enter the GPIB address of the plotter.

CAUTION

Make sure the plotter is really set to the same address!

(4) Plotter output execution and cancellation

① Execution

Now that all the setup has been completed, press .

Perform the plotter output according to the step "(3) Plotter output procedure".

② Cancellation

Press COPY CANCEL enables to cancel the plotter output during the plot is output.

CAUTION

1. The analyzer and all of the plotters that can be used by the analyzer support the protocol HP-GL specification. In setting up mode check that your plotter is set for HP-GL. Some plotters can not support display division. For example, tow picture division can not be done with the HP7470A.

2. When using the HP7475A, set the PAPER SIZE dip switches to: US/A4, US/A3.

5.2.2 Printer Output

(1) GPIB Output

① Connection to the PCL-capable printer

To print out the data in the PCL (Printer Control Language) form, connect the analyzer to a printer by using a GPIB connector.

The HP2225AJ printer produced by Hewlett-Packard Company or the HP2225AJ-equivalent printer can be connected to this unit.

Connect the printer as shown in Figure 5-17.

(If the printer does not have a GPIB connector, use a commercial GPIB-to-parallel converter.)

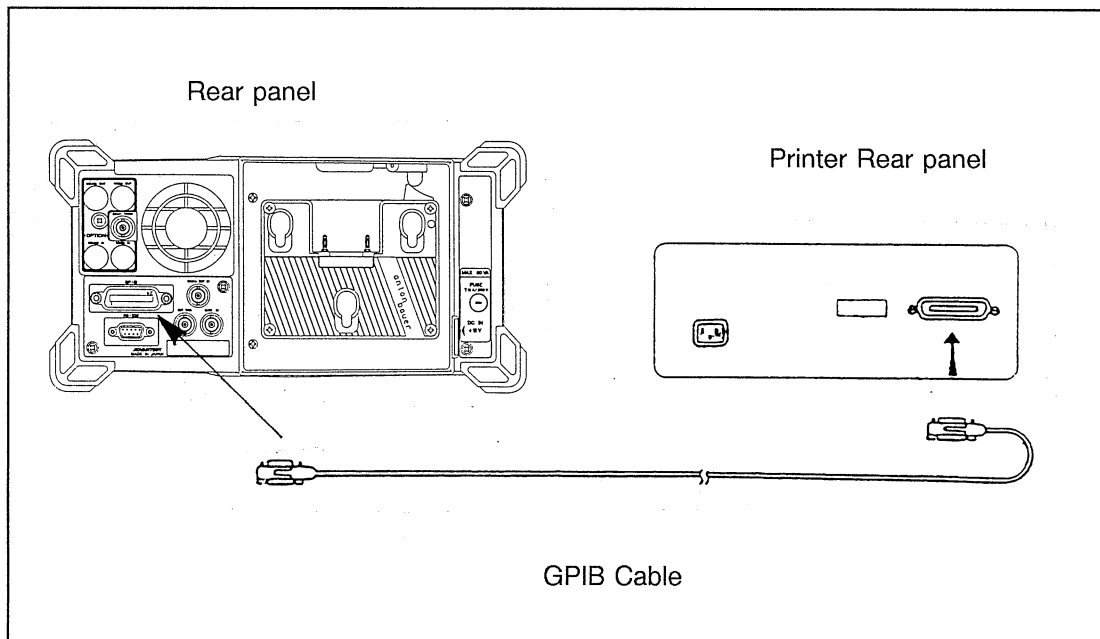

Figure 5-17 Printer connection diagram (Example of the analyzer and HP2225AJ connection)

CAUTION

1. Be sure that the power is OFF before connecting the GPIB cable.
2. Please read the instruction manual for the printer before you begin to use it.

② Printer address

Set the printer GPIB address via its rear panel dip switches. Be sure to set the corresponding talk/listen only mode in the analyzer, or the same address in both the dip switches and the analyzer configuration menu.

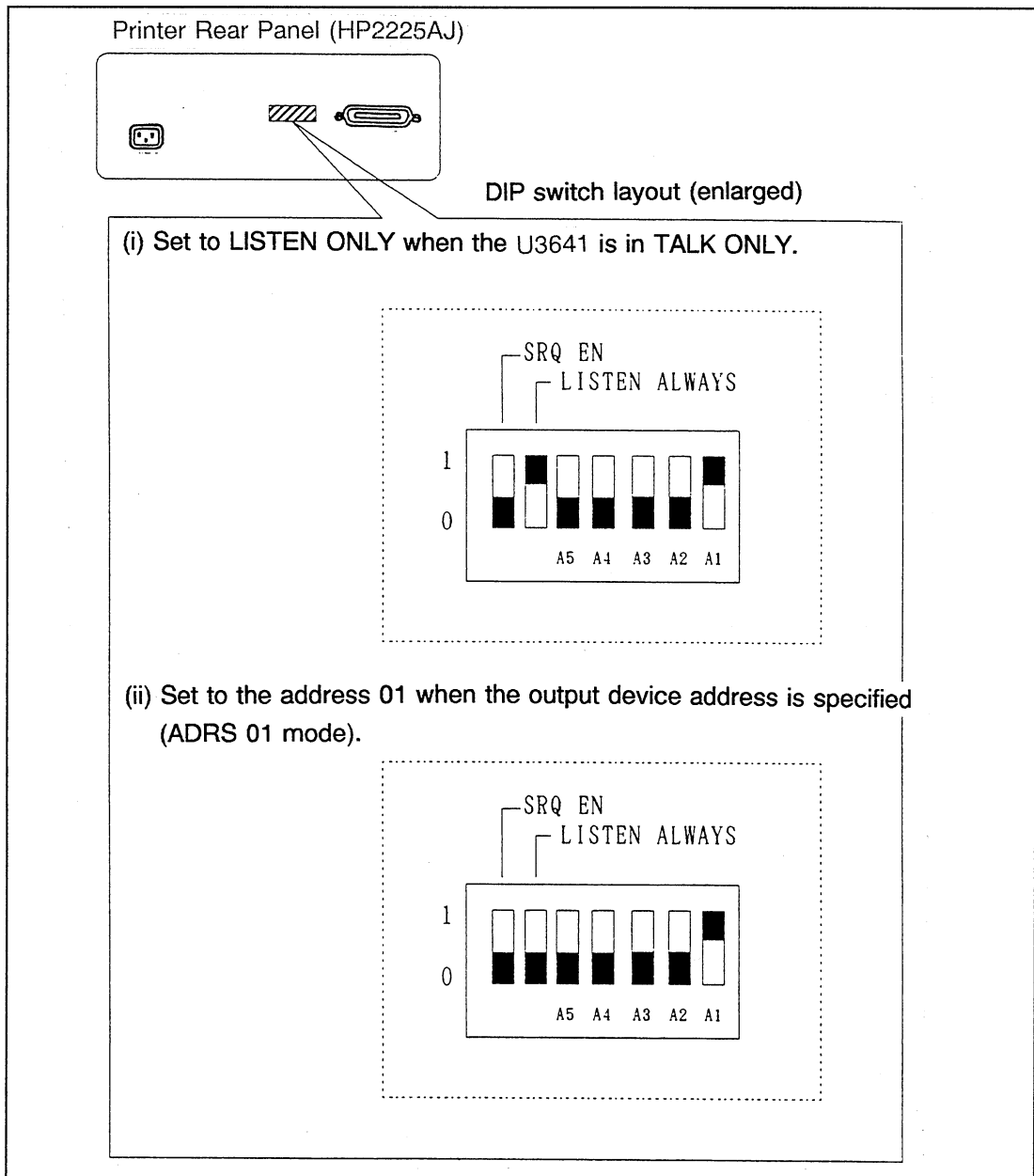

Figure 5-18 Printer address selection dip switch

(2) RS-232 output

① Connection to the ESC/P-capable printer

To print out the data in the ESC/P (Epson Standard Code for Printer) form, connect the analyzer to a printer by using an RS-232 connector. Printers that can be connected to the analyzer are shown in Table 5-5.

Connect the printer as shown in Figure 5-19.

(If the printer does not have an RS-232 connector, use a commercial serial-to-parallel converter.)

Table 5-5 List of printers that can be used with the analyzer (ESC/P language)

Manufacturer	Printer model
Cannon	BJ-10 or its equivalent
SEIKO Epson	VP-600, MJ-400 or its equivalent
Hewlett-Packard	HP505J or its equivalent

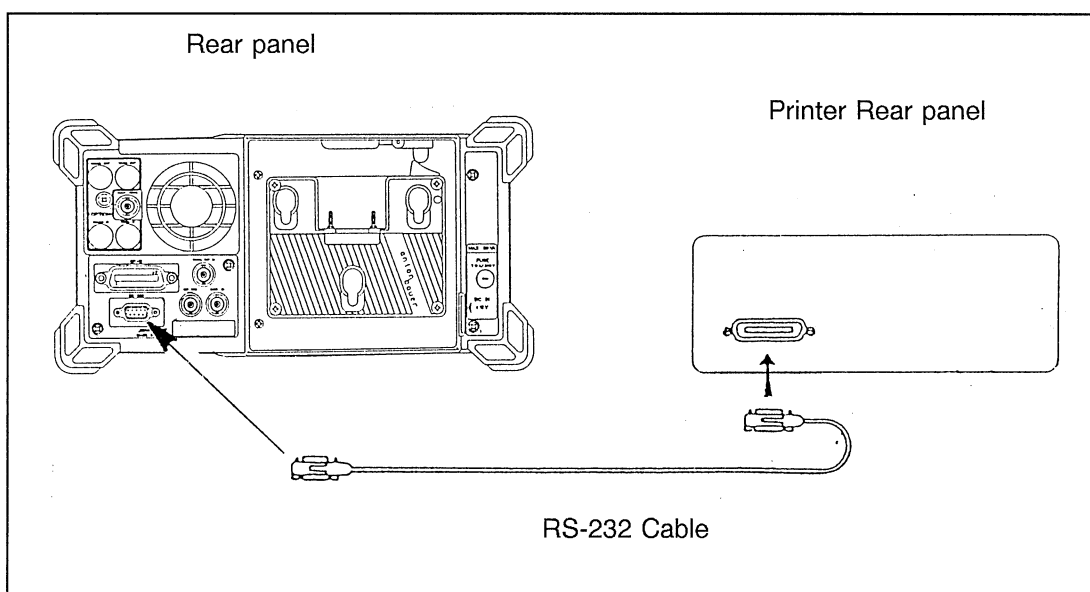

Figure 5-19 Printer connection diagram (Example of the analyzer and VP-600 connection)

— CAUTION —

1. Be sure that the power is OFF before connecting the RS-232 cable.
2. Please read the instruction manual for the printer before you begin to use it.

Two kinds of methods of connecting the RS-232 cable are shown. One is for connecting this unit and the printer directly. The other is for connecting this unit and the printer by using a serial-to-parallel converter.

The name of each signal line used here conforms to the notation of EIA (Electronic Industries Association).

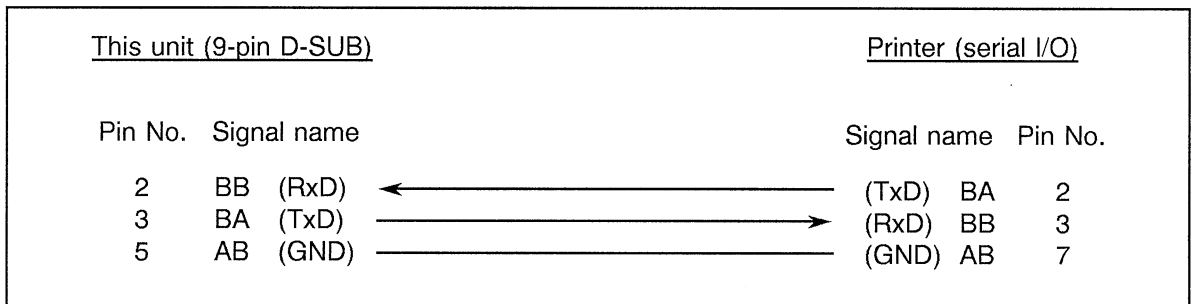

Figure 5-20 RS-232 cable connection diagram for the direct connection

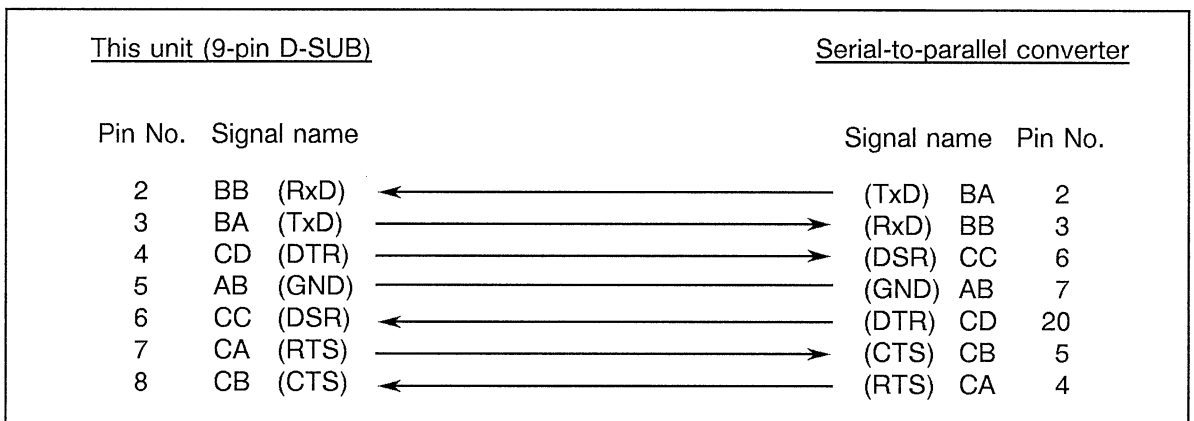

Figure 5-21 RS-232 cable connection diagram for the connection using a serial-to-parallel converter

For details on the signal name, refer to Table 5-7, "Signal names of serial input/output interfaces".

(3) Printer output procedure

CONFIG key is used for the setup printer.

Press COPY key for the print output.

① PRINTER output selection



When the printer has been selected at the output devices where the screen data is sent.

② PRINTER size selection



Selecting LRG: Print in large size.

Selecting SML: Print in small size.

③ GPIB address selection

This is available when the PCL command is selected.



to TALK or ADRS 01.

Selecting TALK : TALK ONLY mode is selected (initial default mode).

Selecting ADRS 01 : The address of the output device must be entered.

Use the NUMERIC key pad,   step key or data

knob  to enter the GPIB address of the printer.

Note: Make sure the printer is really set to the same address!

④ Printer selection with commands

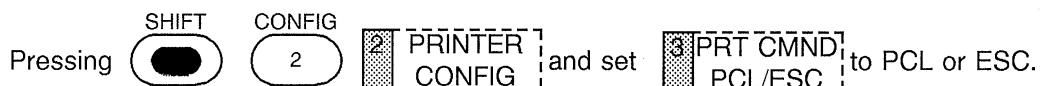



Selecting PCL : Selects the printer to which the PCL command (output from the GPIB port) can be used.

Selecting ESC : Selects the printer to which the ESC/P command (output from the RS-232 port) can be used.





(4) Printer output execution and cancellation

① Execution

Now that all the setup has been completed, press  .

Perform the printer output according to the step "(3) Printer output procedure".

② Cancellation

Press     enables to cancel the printer output during the plot is output.

5.2.3 Memory Card Output

This section explains how to output the screen data to the memory card in the Microsoft Windows bitmap format.

(1) Memory card output procedure

CONFIG key is used for the setup memory card.
Press COPY key for the memory card output.



① Selecting memory card drives.

Press     and   or   in order.

When the drive A (or B) of memory card has been selected at the output devices where the screen data is sent.

② Setting a filename (or the file number of 0001 to 9999) to store in the memory card.

Press       

The file number can be selected using the ten keys,   keys or the knob .

A file extension must be ".BMP" and a file size will be 44.222kbytes.

③ Selecting an automatic file update.

Press      

When selecting ON: The file number is automatically updated.

When selecting OFF: The file number is not updated.

- ④ Selecting bitmap data to be created.



When selecting NORM: A monochrome bitmap data is created.

When selecting INV: A invert monochrome bitmap data is created.

- (2) Memory card output execution

- ① Outputting data to the memory card.



The screen data is output to the memory card on the conditions set in the "(1) Memory card output procedure".

Note : Outputting data to the memory card can not be canceled halfway.

5.2.4 Video Printer Output

CAUTION

Please read the instruction manual for the video printer before you begin to use it.

(1) Connection to a video printer

The COMP VIDEO Connector on the rear panel of this equipment outputs a composite video signal having NTSC standardized amplitude of about 1Vp-p. When used with a BNC input Video Printer this makes for a very simple means of obtaining a hard copy of the display screen. The analyzer and video printer connection diagram is shown in Figure 5-22.

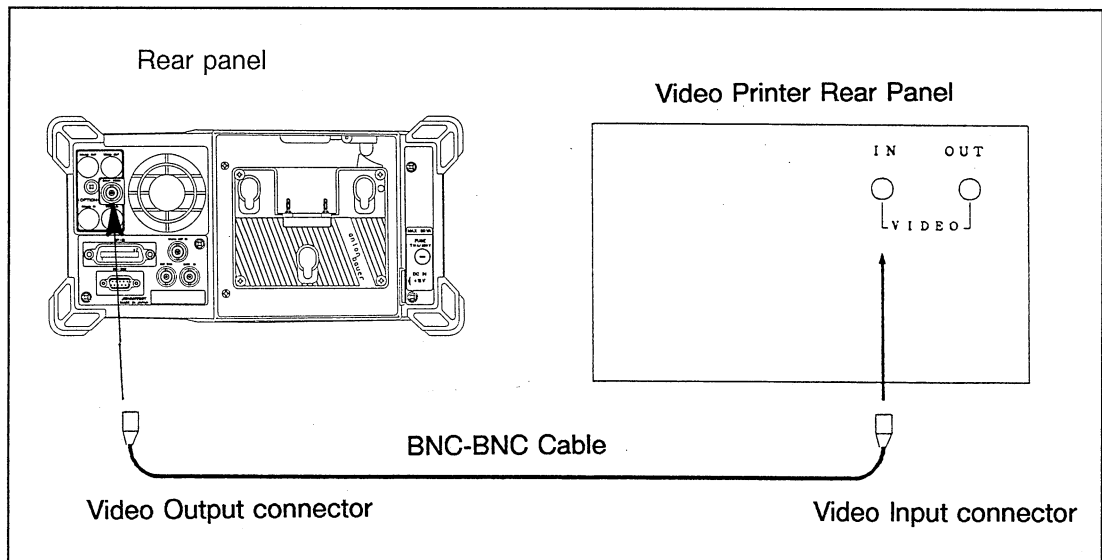

Figure 5-22 Video printer connection diagram

(2) Video printer output operation

The analyzer at all times presents a composite video output signal that corresponds to the current display being seen on the color LCD display. After connection (Figure 5-22), a hard copy can be made at any time by simply pressing the PRINT key on the video printer.

5.3 Saving Data to Memory Card

Memory Cards are used by the analyzer as a storage medium for backing up the current setup/configuration and waveform/spectral data.

As the features of this analyzer, the memory card drive has two slots.

Therefore, two memory cards can be used at a time.

5.3.1 Condition of Memory Card

(1) Memory cards that can be used in the analyzer

Use the memory card which satisfies the following condition.

- ① Use memory cards conforming to either standard of the following.
 - Japan Electronic Industry Developmane Association (JEIDA) IC Memory Card Guideline Version 4.1.
 - United States standards PCMCIA Release 2.0.
- ②
 - Comprises a common memory and an attribute memory including card attribute information (device information-tuple, attribute memory information, common memory information).
 - Comprises only a command memory including card attribute information.
- ③ The following memory types only are available:
 - Common memory : SRAM
 - Attribute memory : Any one of SRAM, EPROM, MASKROM, EEPROM, OTPROM, Flash memory, or none
- ④ Format type
 - MS-DOS format
 - Corresponds to 64KB, 128KB, 256KB, 512KB, 1MB, 2MB

(2) Specification of the Advantest memory card

The specification of the memory card (A09507, CSCJ-256K-SM-461, or CSCJ-002M-SM-461) provided by Advantest is as follows.

Table 5-6 Memory Card Specifications

Memory card Specification	A09507	CSCJ-256K-SM-461 (Compatible product)	CSCJ-002M-SM-461 (Compatible product)
Manufacturer	ADVANTEST	ITT Cannon	ITT Cannon
Memory capacity	64K byte	256K byte	2M byte
Connector	68 pin 2 piece connector		
Interface	JEIDA IC memory card guide line Ver. 4.1 conformity		
Memory backup supply	CR2025 1 each	BR2325 1 each	
Memory backup lifetime (normal temperature)	Approx. 4 years	Approx. 5 years	Approx. 4 years
Exterior dimensions (mm)	54(width) × 86(length) × 3.3 (thickness) mm		
Environmental conditions	No dew condensation Operating temp. range: 0°C to 55°C Storage temp. range: -20°C to 65°C (Data storage is not guaranteed) Relative humidity: 85% or less		
Write protection	Turn ON/OFF using the switch. In the ON position, protection is ON, and the card may not be written to.		



Figure 5-23 Memory card (A09507)

5.3.2 To Use Memory Card

This item will describe the how memory cards are initialized and used.

(1) Memory card insertion and extraction

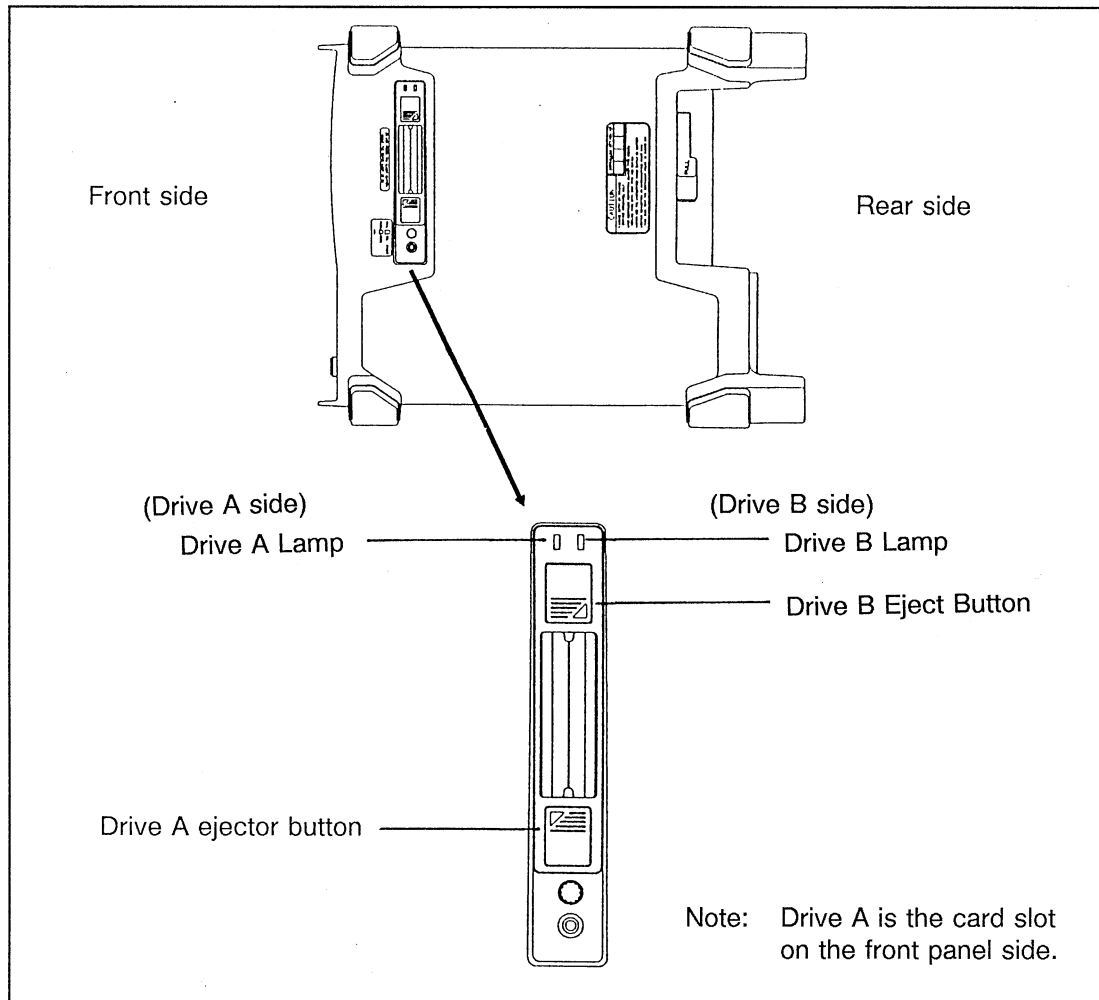

Figure 5-24 Memory card insertion and extraction

The slots for the memory cards are found on the top panel of the analyzer, cards are inserted and removed from above.

- ① Insert cards with their labeled, printed side facing toward the front of the analyzer.
- ② Check to be sure the memory card is not in use (Drive Lamp is always lit on yellow) before operating the Eject Buttons to remove cards from the analyzer.

CAUTION





The Drive Lamp will be lit on red whenever the memory card is being accessed by the analyzer. Never push the ejector and extract a card while the drive lamp is lit on red. If a card should be removed while the access lamp was lit on red, the data in the card cannot be assured and may be destroyed.

(2) Memory card initialization

New or unused memory cards should always be initialized before use.

WARNING

If a memory card containing data is reinitialized all data will be destroyed.

- ① Take the Write Protect off of the card to be initialized.
- ② Insert the memory card.
- ③ Press    and select the active drive.
- ④ Press .

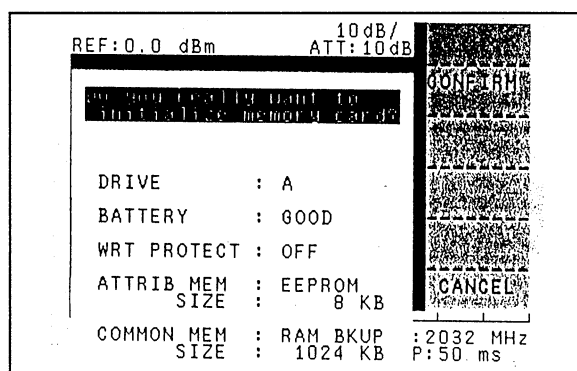



Figure 5-25 Memory card initialization menu

The screen shown in Figure 5-25 will appear. Press  to allow the initialization to proceed.

If the initialization is not required, press  to return to the previous menu.

The following explain the Memory Card Initialization Menu Screen shown in Figure 5-25.

- DRIVE : Indicates a memory card drive to be initialized.
- BATTERY : Indicates a battery information in memory card.
- GOOD : Normal
 - LOW : Though the data is maintained, Battery is dead to exchange it.
 - BAD : Data may not be saved.
Battery is dead to exchange it.
- WRT PROTECT : Indicates a memory card write-protect ON/OFF condition.
- ON : Indicates a memory card write-protected condition.
 - OFF : Indicates a memory card write-enabled condition.
- ATTRIB MEM : Indicates an attribute memory information. (See ※memory type.)
Two kinds of memory cards can be used.
- The memory card comprising a common memory and an attribute memory and including card attribute information (device information-tuple, attribute memory information, common memory information) can be used.
 - The memory card comprising only a common memory and including card attribute information. Can be used.
- SIZE : Attribute memory size
- COMMON MEM : Indicates a common memory. (See ※memory type.)
Only the type "RAM BKUP" can be used.
- SIZE : Common memory size
Size to be used : 64 KB, 128 KB, 256 KB, 512 KB, 1 MB, 2 MB
- ※Memory type : Common memory : SRAM
Attribute memory : Any of SRAM, EPROM, MASKROM, EEPROM, OTPROM or a flash memory.



Note : It is possible that the attribute memory does not exist.
The card without attribute memory does not show the memory type of attribute memory or common memory and the size of attribute memory.

CAUTION

1. When the CONFIRM key is pressed on the initialization menu, and the CANCEL key is pressed during the initialization, the initialization execution is not canceled.
2. The display "FILE EXISTS" on the screen of FORMAT shows that a file exists in the memory card.

(3) Storage to the memory card (Save)

[Saving procedure]

- ① Press   will bring up the screen shown in Figure 5-26.

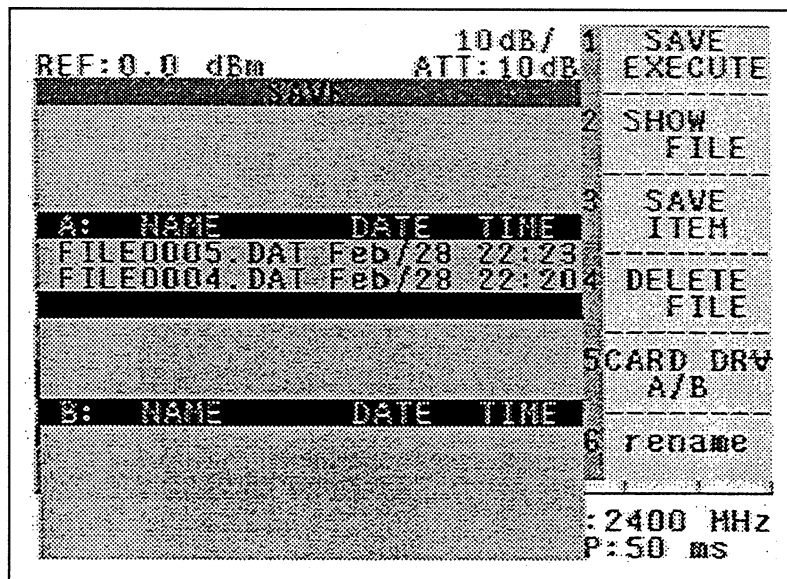







Figure 5-26 SAVE function menu

- ② Select the proper card drive with . The nearest slot to the front panel is the card drive A.
- ③ Make a FILE SELECTION by moving the cursor up and down the file list with the

  step keys or the data knob . To create a new file, move the cursor to the last line in the file list.

- ④ Press   to write the current analyzer state and data to the memory card



according to setting saving condition. (See * Setting saving condition).

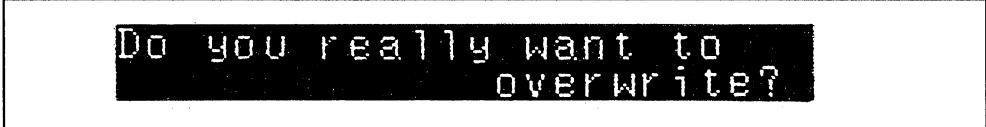

A FILE NAME will also be automatically created at this time.

When an existing file has been selected for overwriting the following message will appear on the message area:



Do you really want to
overwrite?

- Press   to continue with the overwriting.



When the overwriting is not required, press   to return to the previous menu from the overwriting menu.

CAUTION

When the CONFIRM key is pressed, and the CANCEL key is pressed during the overwriting, the overwriting execution is not canceled.

[Setting saving condition]

Before the in saving, the conditions of data to be saved can be changed as follow.

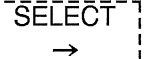
- ① Select a format of data to be saved.
Move the cursor to an item to select with the knob .
- ② Addition and cancellation of the current setup conditions
Press   to change ON or OFF of the item.

Initial values (Figure 5-27) of the save conditions and items of the selection are as follows.

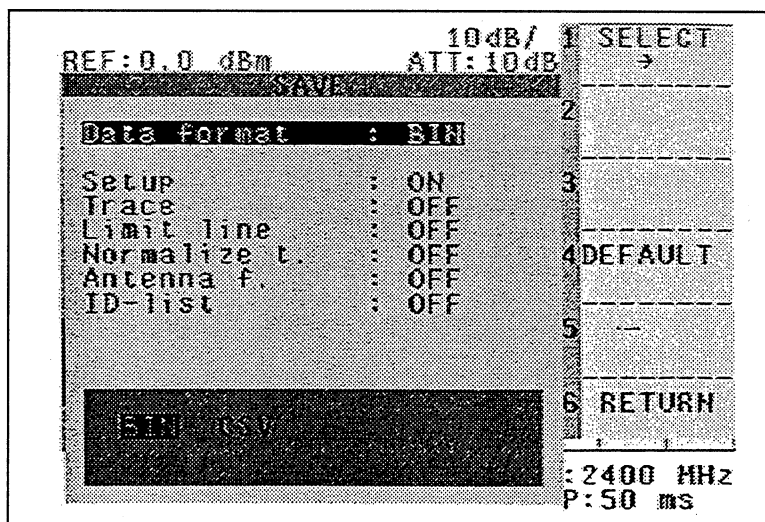

Figure 5-27 Initial value of save conditions

Data format : File type
 BIN : Saves data in the internal code.
 CSV : Saves data in Comma Separated Value form. (Tabular format)
 (Note) When the CSV format is selected, items which can be saved gets fewer. Examples are shown in A1-3, "Memory Card CSV format".

Setup data

Trace

Limit line

ID-list

(Normalize t. and Antenna f. can not be saved.)

CAUTION

1. Files which were saved in CSV type cannot be recalled.
2. When the files which were saved in CSV type are shown (SHOW FILE), only the file name, the size, the time, and the label are displayed.

Setup : Setup data (Setup conditions of display screen)
 OFF : Setup data is not saved.
 ON : Setup data is saved.

**SPECTRUM ANALYZER
OPERATION MANUAL**

5.3 Saving Data to Memory Card

- Trace : Waveform data
 OFF : Waveform data is not saved.
 A : Waveform data A is saved.
 B : Waveform data B is saved.
 A/B : Waveform data A/B are saved.
 (Note) When trace mode is BLANK, waveform data are not saved.
- Limit line : Limit line
 OFF : Limit line is not saved.
 1 : Limit line 1 is saved.
 2 : Limit line 2 is saved.
 1/2 : Limit lines 1/2 are saved.
- Normalize t. : Normalize data
 OFF : Normalize data is not saved.
 ON : Normalize data is saved.
 (Note) When you recall the normalize data, you can save it to either the backup memory or the memory (the data of the latter is lost when powering off the spectrum analyzer). For more information, refer to  in "7.2.4 Normalize Mode".
- Antenna f. : Antenna compensated data
 OFF : Antenna compensated data is not saved.
 ON : Antenna compensated data is saved.
- ID-list : ID-list
 OFF : ID list is not saved.
 ON : ID list is saved.
 (Note) ID list is saved when data exists.

[Savable files number]

The following shows examples of savable files number in BIN form. Use them as a guide in saving.

Item Card	Setup data only	Setup data + Waveform A	Setup data + Waveform A + B	Setup data + Waveform A + Limit 1
64K	59 files	29 files	16 files	19 files
256K	128	125	71	83
2M	128	128	128	128

(Note) Maximum number of registerable files: 128 files

(4) Reading back from a memory card (RECALL)

(4-1) In NORMAL mode

- ① Press  and the screen shown in Figure 5-28 will appear.

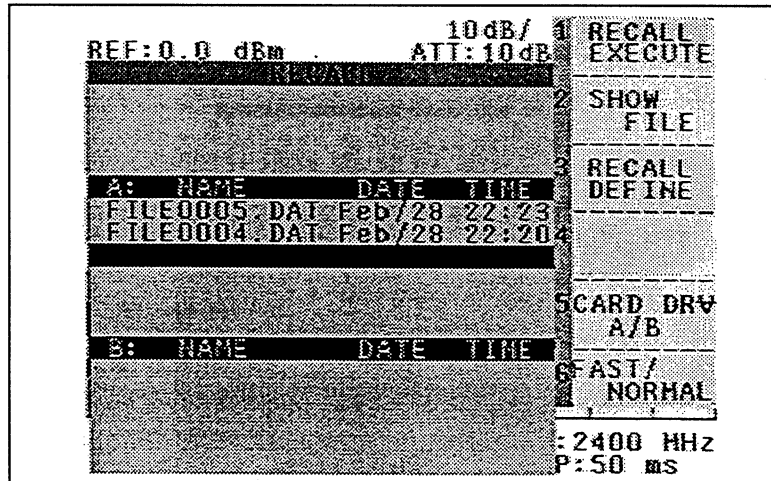
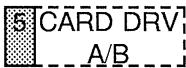
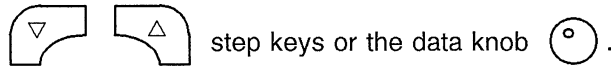



Figure 5-28 RECALL function menu (in NORMAL mode)

- ② Select the proper memory card drive with the toggle 

The card in the slot nearest to the front panel is Drive A.



- ③ Make a file selection by moving the cursor up and down the file list with the







To find out what any file in the list contains at this point, press 

- ④ Press  to recall the selected file setting conditions.

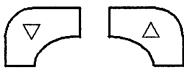
(4-2) In FAST mode

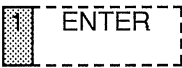
- ① Press   and the screen shown in Figure 5-29 will appear.

- ② Specify a register number with the  step keys and a file of memory card with the knob , and then press  to setup the file in the register number.

- ③ Press , ten key (any one setup register number from 1 to 9) in order and the assigned file setting conditions will be recalled.

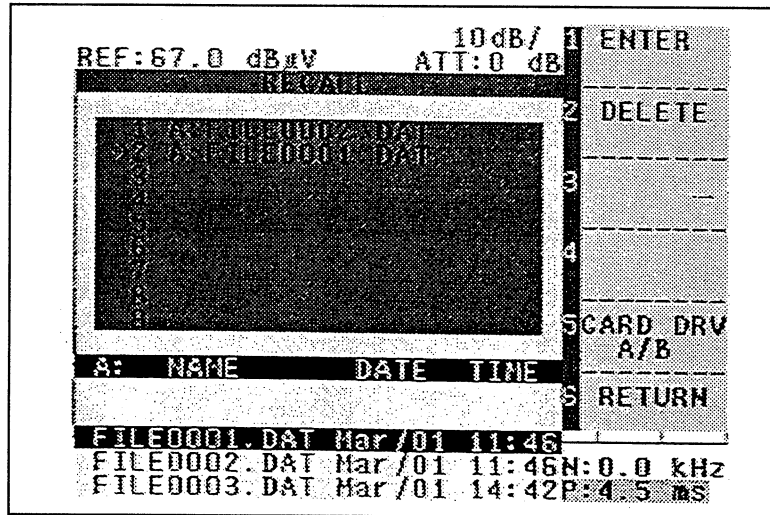





Figure 5-29 RECALL DEFINE menu screen

(5) Memory card backup procedure

Using the two analyzer's drives enables to backup (ALL COPY function) the memory card data due to exchange batteries, etc.

- ① Insert a master memory card into active drive. Also, insert a blank, initialized memory card (the capacity shall be same as the master's one) into the other drive to copy the all data.
- ② Select the active drive.

Press   , and select the master memory card (active drive).

(Here, for example select the drive A.)

- ③ Copy the all data in the master memory card (active drive) to the other memory card.

Press   .

The following message will appear on the message area.

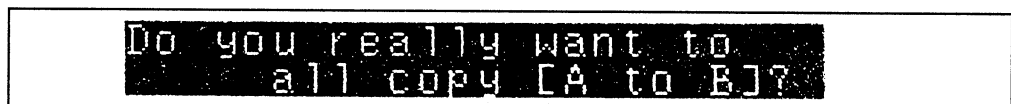

Press  to execute the all data copy.

Press  to return to the previous menu from the ALL COPY function menu.

CAUTION

1. When the CONFIRM key is pressed and the CANCEL key is pressed during overwriting, COPY execution cannot be canceled.
2. If the both memory capacities are different, the all copy cannot be executed.

5.3.3 Cautions in Handling Memory Card

(1) Backup battery lifetime

A battery is necessary for preserving data in any memory cards that use SRAM.

The battery lifetime is dependent on the static power dissipation of the memory card RAM, and the dissipation increases with increasing RAM capacity, resulting in decreased lifetime.

A 64 KB memory card with a new battery installed and then kept at room temperature will have a battery lifetime of 4 years, a similarly treated 256 KB card's battery will last 5 years, and similarly treated 2 MB card's battery will last 4 years.

For information on how to replace the battery, refer to the instruction manual that comes with the memory card.

WARNING

Precautions in using memory cards.

1. Battery lifetime will be greatly reduced if a memory card is left exposed to elevated temperatures.
2. Please remove memory cards from the analyzer when they are not in use.
3. Keep dust and foreign matter out of the connector holes.
Avoid bad contact or damage to the connector.
4. Do not touch the connector with metallic wires or pins, etc.
Avoid damaging static discharge.
5. Do not bend or subject the card to strong shocks.

(2) Loading data from BMP and CSV files

The load data saved in the memory card into a personal computer, the personal computer may have to be set up.

For the setup procedure, refer to the operating manual of the computer.

5.4 RS-232 Remote Control Function

With controllers not equipped with a GPIB interface as a standard, such as personal computers, a simple measurement system can be configured using an RS-232 interface.

The RS-232 also allows remote control to be controlled externally similar to the GPIB interface.

(1) Compatibility with GPIB codes

The RS-232 uses the same codes as the GPIB of the analyzer, except for GPIB-specific codes and functions. (Refer to "11.9 GPIB Codes List").

① Compatibility with GIB codes

- The codes are compatible with the talker/listener codes.
- The codes are compatible with the header information corresponding to the talker request.
- The codes are compatible with the output formats.

② GPIB codes not supported

- Delimiter control : DL0, DL1, DL2, DL3, DL4
- SRQ interrupt : S0, S1

③ Command added for RS-232

- Panel key lock control : KLK, KUK
- Status byte read out : PLL?

④ Panel control

The following specifications are used for the execution of RS-232 remote programming. (When GPIB remote programming is executed, the remote lamp on the panel lights up, automatically inhibiting local operation.)

- Remote lamp does not light up.
- Local operation should not be inhibited until the KLK command is sent out.
- If the KLK command inhibits local operation, the operation should not be automatically canceled unless it is not canceled by the KUK command.
- If the local operation is ended while it is not canceled using the command after it has been inhibited, the LCL or IP command can cancel it.

(2) Functions controlled externally

The following functions can be controlled using the RS-232 remote control:

- ① Setting of measurement conditions : Input of various measurement conditions similar to the conditions input by key operation on the panel
- ② Output of settings : Output of various settings and data of this system
- ③ Input/output of measurement data : Write-in/readout of screen trace data
- ④ Status output : Readout of data indicating the current conditions of the measurement instrument similar to status bytes in the GPIB

5.4.1 RS-232 Specifications

(1 of 2)

Item	Description
(1) Transfer speed (baud rate)	<p>The following six speeds are available.</p> <ul style="list-style-type: none"> ① 600 bps ② 1200 bps ③ 2400 bps ④ 4800 bps ⑤ 9600 bps ← Default value ⑥ 19200 bps
(2) Data length	<p>The following two lengths are available.</p> <ul style="list-style-type: none"> ① 7 bits ← Default value ② 8 bits
(3) Stop bit length	<p>The following three stop bit lengths are available.</p> <ul style="list-style-type: none"> ① 1 bit ← Default value ② 1.5 bit ③ 2 bit
(4) Parity bit	<p>The following three parity methods are available.</p> <ul style="list-style-type: none"> ① Without parity ← Default value ② Odd parity ③ Even parity
(5) Communication method	Half duplex
(6) Data flow control	<p>Specifies the handshake method used in the communication with the controller. The following two methods are available, depending on the function of the communication port at the controller.</p> <ul style="list-style-type: none"> ① Hard-wired handshake ← Default value The RS-232 interface does not send out data while the DSR line at the sending end is low. Also, while the DTR line in the system is low, the data from the mating end will be rejected. ② Xon/Xoff handshake The sending end does not send data until it has received the next Xon characters after receiving the Xoff characters through the data line. Also, if the system is not ready to receive data, it will send the Xoff characters to indicate data rejection from the mating end. As soon as it is ready to receive data, it will send the Xon characters.
(7) Inter-character sending interval	<p>Places a fixed time interval between each character when the system sends data. This reduces the load at the controller. The following five setting values are available.</p> <ul style="list-style-type: none"> ① 0 ← Default value ② 1.0 ms ③ 2.5 ms ④ 4.0 ms ⑤ 5.5 ms

(2 of 2)

Item	Description
(8) Communication mode	The system employs the start-stop mode and uses "carriage return" (CR) and "line feed" (LF) as delimiter symbols of messages. Note: A special mode is employed only for the binary output of waveform data. Refer to "5.4.4 Extended Formats".
(9) Transmission error control	The system does not perform error control. If necessary, the control should be made at the controller.
(10) Communication port open	The RS-232 port is opened when the system is switched on. Since the parameters necessary for communication are stored in the memory, panel/softkey operations open the port with the setting currently stored. When the port is initially opened after shipment, the initial settings are used. Also, the panel/softkey operations will forcibly close the communication port.

5.4.2 Connection

(1) Connection with controller

The RS-232 cable is used to connect the analyzer and the controller as follow.

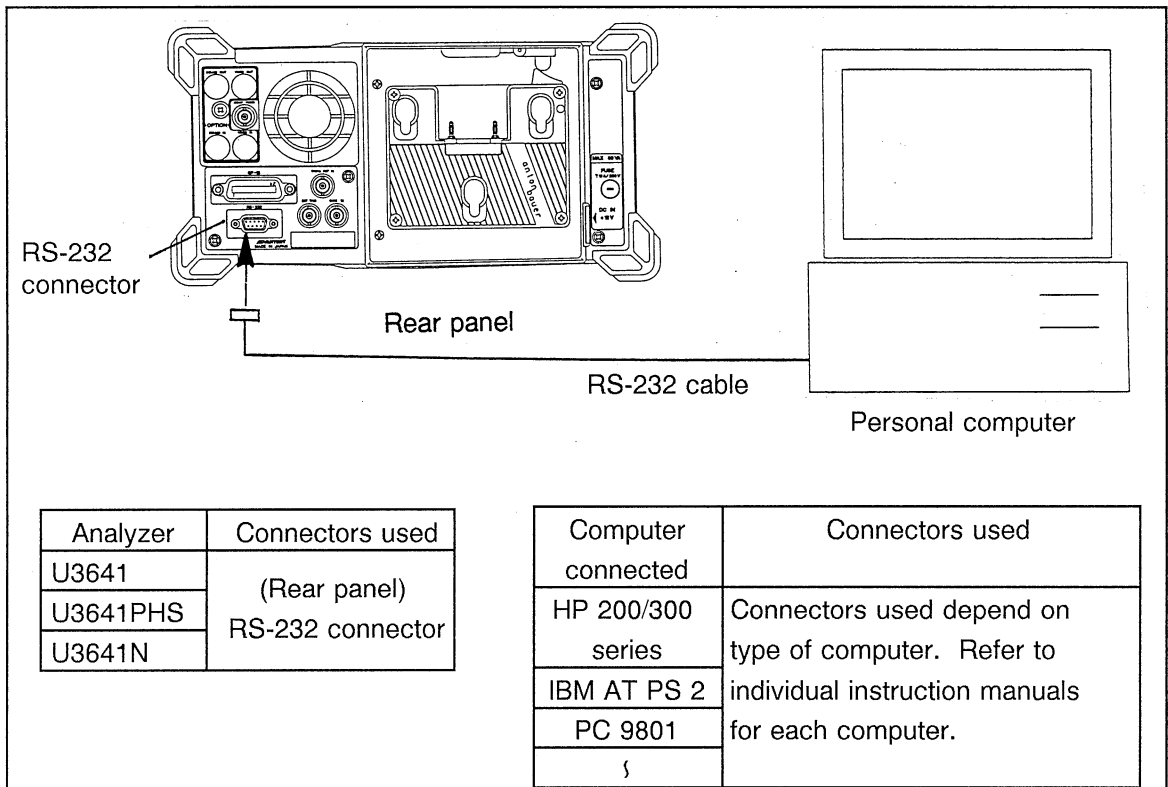

Figure 5-30 Connection to personal computer

**SPECTRUM ANALYZER
OPERATION MANUAL**

5.4 RS-232 Remote Control Function

The following describes how to connect the RS-232 cable to a controller such as a personal computer. The names of each signal line used here comply with the notation of the EIA (Electronic Industries Association).

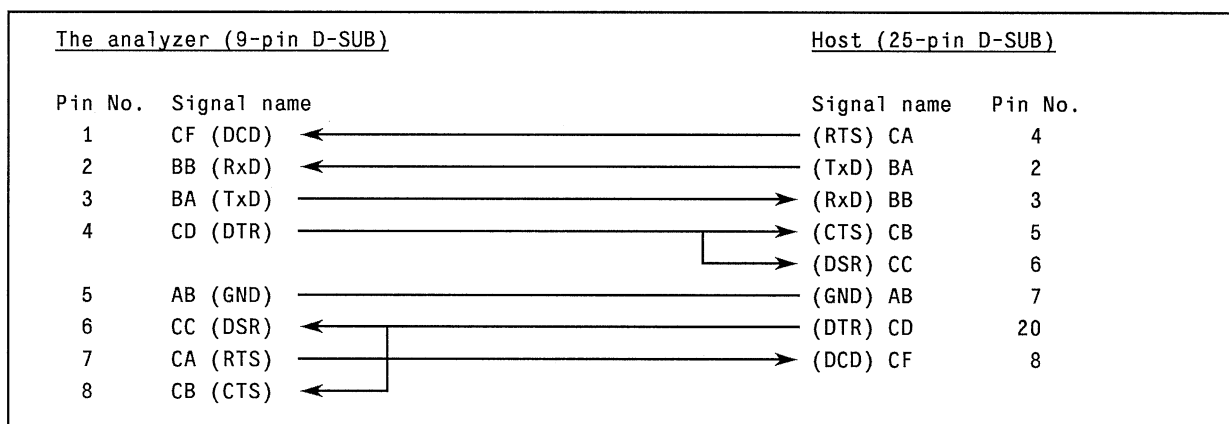

Figure 5-31 Cable connection diagram

Table 5-7 Signal names of serial input/output interfaces

Pin No.	Signal name		Signal direction		Description
			Analyzer	External	
1	Carrier detector	DCD	←		"High" when carrier is received normally.
2	Receive data	RXD	←		Receive data
3	Transmit data	TXD	→		Transmission data
4	Data terminal Ready	DTR	→		Data terminal ready
5	Signal ground	SG			Signal ground
6	Data set ready	DSR	←		"High" when external device is ready for communication.
7	Request to send	RTS	→		Transmission request signal to external device. When high level, ready for receiving. When low level, receiving inhibited.
8	Clear to send	CTS	←		Transmission permission signal. When high level, ready for transmission. When low level, transmission inhibited.
9	Ground	FG			Frame ground. Used for protection ground.

5.4.3 Communication Port Setting

The CONFIG key is used to set the communication ports of the RS-232 interface in the system.

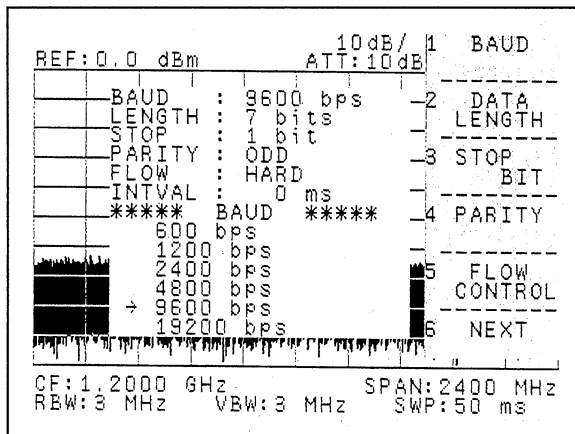

Figure 5-32 Window screen for communication port setting

- Window screen for setting communication ports.

Press **SHIFT** **CONFIG** **6** **NEXT**

1 **SETUP** **RS232**

and the window screen shown in Figure 5-32 will appear. The upper portion of the window screen shows the current settings, and the lower portion is used to change each parameter. Use the marker (→) to change them.

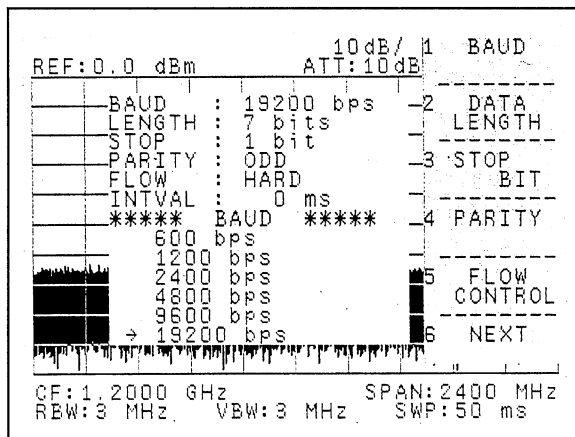

Figure 5-33 Transmission speed setting

- Transmission speed setting (baud rate)

Press **1** **BAUD** on the display

softmenu shown in Figure 5-32. Each time this softkey is pressed, the "→" will move, enabling the transmission speed to be select.

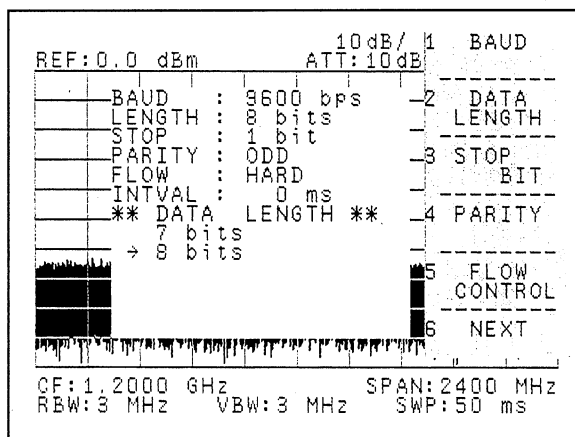

Figure 5-34 Data length setting

- Data length setting.

Press **2** **DATA** **LENGTH** on the display

softmenu shown in Figure 5-33. Each time this softkey is pressed, the "→" will move, enabling the data length to be select.

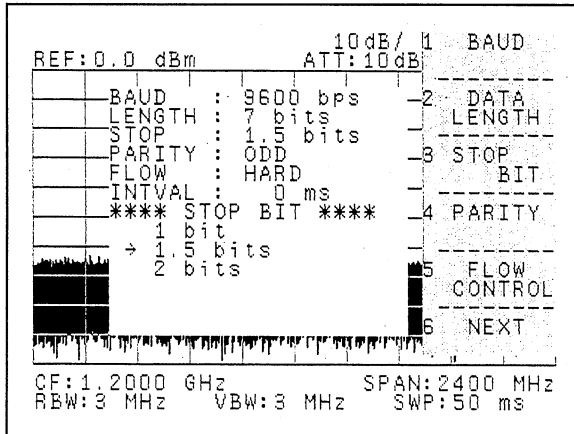

Figure 5-35 Stop bit setting

④ Stop bit setting

Press **3** **STOP BIT** on the display

softmenu shown in Figure 5-34. Each time this softkey is pressed, the "→" will move, enabling the stop bit to be select.

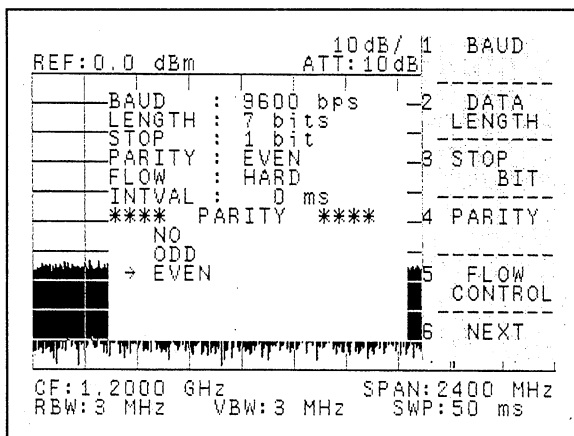

Figure 5-36 Parity bit setting

⑤ Parity bit setting

Press **4** **PARITY** on the display

softmenu shown in Figure 5-35. Each time this softkey is pressed, the "→" will move, enabling the parity bit to be select.

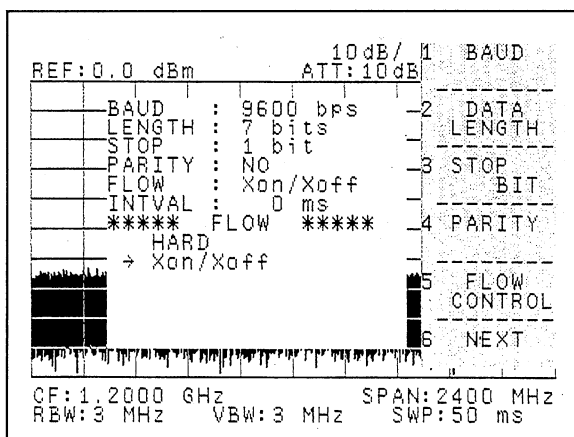

Figure 5-37 Data flow control setting

⑥ Data flow control method setting

Press **5** **FLOW CONTROL** on the display

softmenu shown in Figure 5-36. Each time this softkey is pressed, the "→" will move, enabling the data flow control method to be select.

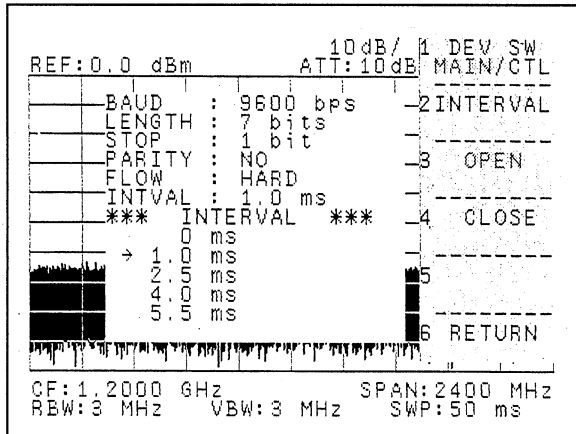

Figure 5-38 Interval time setting

⑦ Interval time setting

Press **6** NEXT on the display

softmenu shown in Figure 5-37 to display the next softmenu and then press **2** INTERVAL

Each time this softkey is pressed, the "→" will move, enabling the transmission interval time between each character to be select for the transmission from the system.

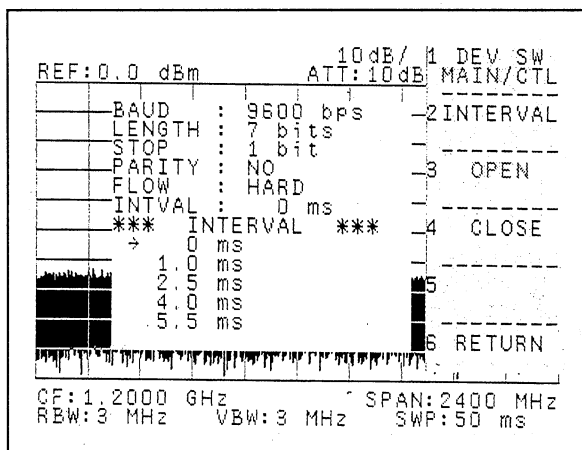

Figure 5-39 Communication port open setting

⑧ Communication port open setting

Press **3** OPEN on the display

softmenu shown in Figure 5-38. When this softkey is pressed, the communication port will be opened.

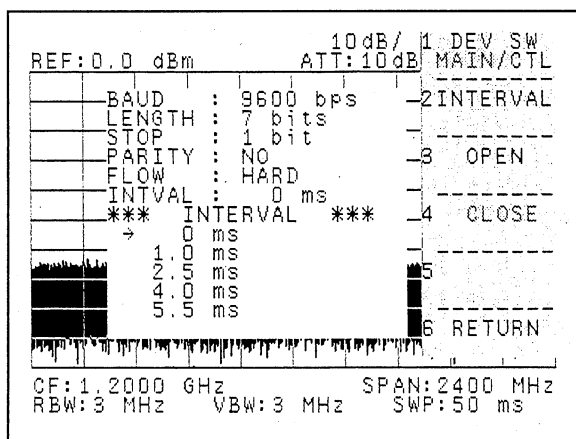

Figure 5-40 Communication port close setting

⑨ Communication port close setting

Press **4** CLOSE on the display

softmenu shown in Figure 5-39. When this softkey is pressed, the communication port will be closed.

5.4.4 Message Format

The messages which are transmitted between the controller and the system are basically ASCII-code character strings. The ends of the messages are indicated by "carriage return (CR) and line feed (LF)" codes.

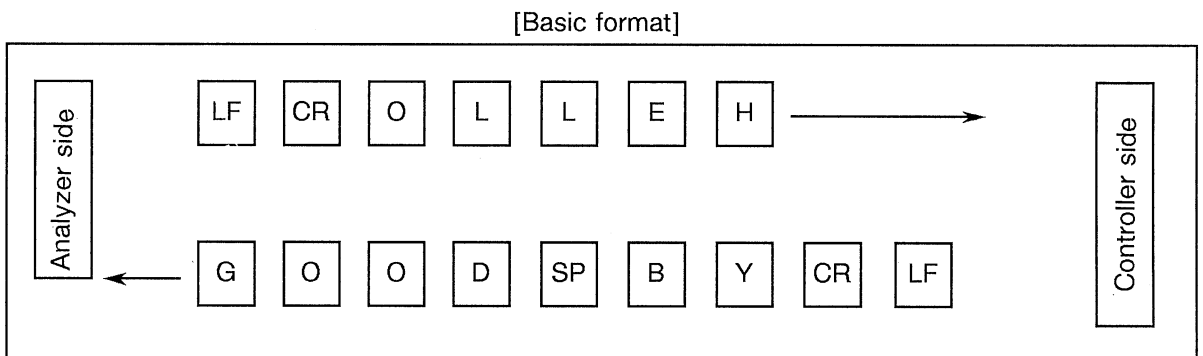

When waveform data are transmitted in binary format, the extended transmission format is used.

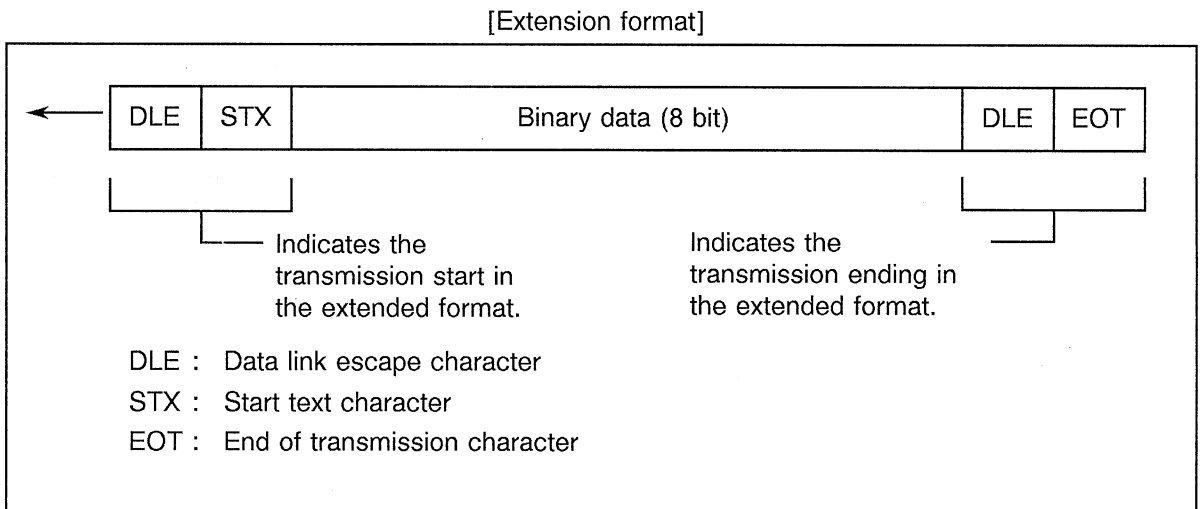

In this case, if the binary data include data with the same codes as the DLE character, messages are sometimes ended by mistake. For this reason, the sending end inserts an excess DLE character for transmission. When the receiving end receives the continuous DLE characters, it recognizes the excess and ignores it. (For an example of data handling of this kind, refer to "5.4.5 RS-232 Remote Program Examples, Sample Program Ex.14 and Ex.15".)

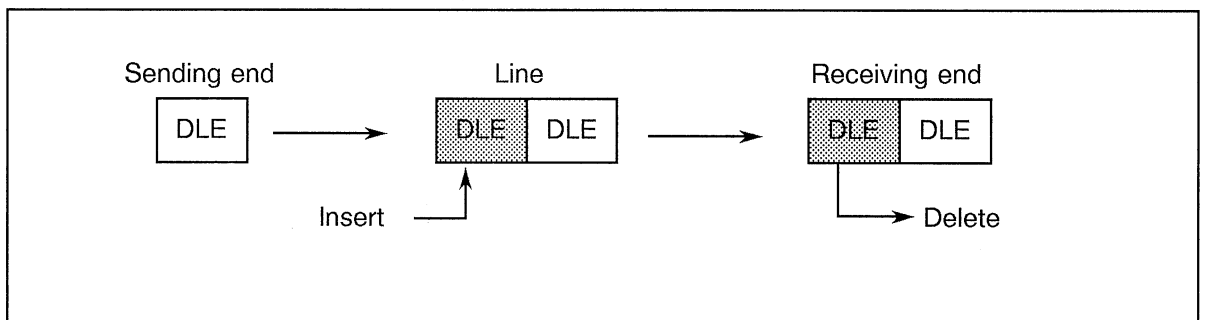

List of control character codes are shown below.

Table 5-8 List of Control Character Codes

Symbols	Codes hex.	Content
STX	02h	Used for header character during binary data transmission.
EOT	04h	Used for delimiter character during binary data transmission.
LF	0Ah	Used for delimiter character during ASCII data transmission.
CR	0Dh	Used for delimiter character during ASCII data transmission.
DLE	10h	Control character during binary data transmission.
Xon	11h	Start character during X parameter transmission.
Xoff	13h	Prevention character during X parameter transmission.

5.4.5 RS-232 Remote Programming Examples

This subsection uses examples of actual programming to describe how to use the RS-232 remote control functions. Note that the programs used in this subsection use Microsoft's "Quick BASIC". Several sample programs use NEC's "N88-BASIC" and Hewlett Packard's "HP-BASIC".

Microsoft's "Quick BASIC" : ex1 to ex19
NEC's "N88-BASIC" : ex8, ex10, ex17
Hewlett Packard's "HP-BASIC" : ex17

(1) How to use the serial I/O

Example 1 : Master-resets the analyzer and turns ON the CAL signal (30 MHz). The port is opened with the conditions:

- RS-232 port : 9600 bps
- Parity : none
- Data length : 8 bits
- Stop bit : 1 bit
- Binary mode (except for Xon/Xoff control)
- Line feed : character insert mode
- DSR line monitor time-out time : 6 s

```
OPEN "COM1:9600,N,8,1,DS6000,LF" FOR RANDOM AS #1  
  
PRINT #1, "IP"  
PRINT #1, "CLN"  
END
```

Example 2 : Sets the start frequency to 300 kHz and the stop frequency to 800 kHz, and adds a frequency offset of 50 kHz.

```
OPEN "COM1:9600,N,8,1,DS6000,LF" FOR RANDOM AS #1  
  
PRINT #1, "FA300KZ"  
PRINT #1, "FB800KZ"  
PRINT #1, "FON50KZ"  
END
```

SPECTRUM ANALYZER
OPERATION MANUAL

5.4 RS-232 Remote Control Function

Example 3 : Sets the reference level to -20 dBm (5 dB/div), the resolution bandwidth to 100 kHz, and the detector mode to posi..

```
OPEN "COM1:9600,N,8,1,DS6000,LF" FOR RANDOM AS #1

PRINT #1, "RE-20DB"           'Reference level: -20 dBm.
PRINT #1, "DD5DB"            '5 dB/div
PRINT #1, "RB100KZ"         'Resolution bandwidth: 100 kHz
PRINT #1, "DTP"              'Detector mode: posi.
END
```

Example 4 : Sets the trigger mode to single and the sweep time to 2 s, so that the marker will reach the maximum level for each sweeping.

```
OPEN "COM1:9600,N,8,1,DS6000,LF" FOR RANDOM AS #1

PRINT #1, "SI"
PRINT #1, "SW2SC"

SWLOOP:
  PRINT #1, "S2"              'Status byte clear
  PRINT #1, "SR"              'Start of sweeping
  DO                           'Waits for end of sweeping
    PRINT #1, "PLL?"
    INPUT #1, A$
    SB = VAL(A$)
  LOOP UNTIL SB AND &H4
  PRINT #1, "PS"              'Marker peak search
GOTO SWLOOP
END
```

Example 5 : Sets to MAX HOLD (A).

```
OPEN "COM1:9600,N,8,1,DS6000,LF" FOR RANDOM AS #1

PRINT #1, "AM"                'Sets to DIRECT.
END
```

**SPECTRUM ANALYZER
OPERATION MANUAL**

5.4 RS-232 Remote Control Function

Example 6 : Executes the RECALL (in the case of file name "FILE0001").

```
OPEN "COM1:9600,N,8,1,DS6000,LF" FOR RANDOM AS #1

PRINT #1, "RC /A:FILE0001/"           'Recalls file name "FILE0001".
```

Example 7 : Outputs the marker frequency (integer).

```
OPEN "COM1:9600,N,8,1,DS6000,LF" FOR RANDOM AS #1

PRINT #1, "HDO"                       'Header output prevention
PRINT #1, "MF?"
INPUT #1, A$
B = VAL(A$)                            'Example result B = 1700000
END
```

Example 8 : Outputs the center frequency (character strings).

Example 8-1 : For Quick BASIC

```
OPEN "COM1:9600,N,8,1,DS6000,LF" FOR RANDOM AS #1

PRINT #1, "HD1"                       'Starts header output.
PRINT #1, "CF?"
INPUT #1, A$
                                        'Example result A$ = CF 0000001.8000E + 9

END
```

Example 8-2 : For N88-BASIC

```
10 OPEN "COM1:N83NN" AS #1
20 PRINT #1, "HD1"
30 PRINT #1, "CF?"
40 INPUT #1, A$
50 END
```

Example 9 : Outputs the unit conditions.

```
OPEN "COM1:9600,N,8,1,DS6000,LF" FOR RANDOM AS #1

PRINT #1, "UN?"
INPUT #1, A                             'Example result A = 2 (dBuv)
END
```

SPECTRUM ANALYZER
OPERATION MANUAL

5.4 RS-232 Remote Control Function

Example 10 : Outputs the marker frequency and the level simultaneously.

Example 10-1 : For N88-BASIC

```
OPEN "COM1:9600,N,8,1,DS6000,LF" FOR RANDOM AS #1

PRINT #1, "HDO"                'Header output prevention
PRINT #1, "MFL?"
INPUT #1, Mf$, M1$
Mff = VAL(Mf$)                 'Example result  Mff= 1.8E +09 M11 = -73.02
M11 = VAL(M1$)
END
```

Example 10-2 : For N88-BASIC

```
10 OPEN "COM1:N83NN" AS #1
20 PRINT #1, "HDO"
30 PRINT #1, "MFL?"
40 INPUT #1, MF$, ML$
50 Mff=VAL(MF$)
60 M11=VAL(ML$)
70 END
```

Example 11 : Outputs the frequency offset.

```
OPEN "COM1:9600,N,8,1,DS6000,LF" FOR RANDOM AS #1

PRINT #1, "HDO"                'Header output prevention
PRINT #1, "FO?"
INPUT #1, On$, Frp$
Frqq=VAL(frq$)                 'Example result  On$ = 1 Frqq = 1200000
END
```

Example 12 : Using NEXT PEAK, reads out the 10 peak levels from the second peak level of a signal.

```
DIM M1$(9), M11(9)
OPEN "COM1:9600,N,8,1,DS6000,LF" FOR RANDOM AS #1

PRINT #1, "PS"
FOR I = 0 TO 9
  PRINT #1, "NXP"
  PRINT #1, "ML?"
  INPUT #1, M1$(I)
  M11(I) = VAL(M1$(I))
NEXT I
                                'Example result  M11(1) = -55.01 M11(2) = -58.22 ... M11(9) = -70.26
END
```

(2) Input/output of trace data

The input/output of the trace data is basically the same as that of the GPIB. Its ASCII format uses similar specifications for the contents of data values, message format, delimiter (fixed), and number of transmission times. Although the binary format uses the same specifications for data values, data transmission order, and number of data bytes as that of the GPIB, control characters are inserted at the start and end of the data. (Refer to "Extended Formats" of "5.5.4 Message Formats".)

In addition, it should be noted that if the data include the same character as the DLE character, an excess DLE character will be inserted. (Note: Be sure to use 8-bit data for execution. If 7-bit data are transmitted, an incorrect waveform may be generated because of the absence of the most significant bit in the waveform.)

How to input/output	Description									
ASCII format	<p><u>DDDD</u> CR LF Data corresponding to one point</p> <p style="text-align: center;">4-byte data without header</p> <table border="1" style="margin-left: auto; margin-right: auto; border-collapse: collapse;"> <thead> <tr> <th style="width: 20%;"></th> <th style="width: 40%;">Input code</th> <th style="width: 40%;">Output code</th> </tr> </thead> <tbody> <tr> <td>Memory A</td> <td style="text-align: center;">TAA</td> <td style="text-align: center;">TAA?</td> </tr> <tr> <td>Memory B</td> <td style="text-align: center;">TAB</td> <td style="text-align: center;">TAB?</td> </tr> </tbody> </table>		Input code	Output code	Memory A	TAA	TAA?	Memory B	TAB	TAB?
	Input code	Output code								
Memory A	TAA	TAA?								
Memory B	TAB	TAB?								
Binary format	<p><u>DLE STX</u> DD DD DD DD <u>DLE EOT</u></p> <div style="display: flex; justify-content: space-around; align-items: center;"> <div style="text-align: center;"> <p>Least significant of first point</p> <p>Most significant of first point</p> </div> <div style="text-align: center;"> <p>Least significant of 701st point</p> <p>Most significant of 701st point</p> </div> </div> <p>One-point data are divided into two bytes (most and least significant bytes) of the binary value for transmission.</p> <table border="1" style="margin-left: auto; margin-right: auto; border-collapse: collapse;"> <thead> <tr> <th style="width: 20%;"></th> <th style="width: 40%;">Input code</th> <th style="width: 40%;">Output code</th> </tr> </thead> <tbody> <tr> <td>Memory A</td> <td style="text-align: center;">TBA</td> <td style="text-align: center;">TBA?</td> </tr> <tr> <td>Memory B</td> <td style="text-align: center;">TBB</td> <td style="text-align: center;">TBB?</td> </tr> </tbody> </table>		Input code	Output code	Memory A	TBA	TBA?	Memory B	TBB	TBB?
	Input code	Output code								
Memory A	TBA	TBA?								
Memory B	TBB	TBB?								

**SPECTRUM ANALYZER
OPERATION MANUAL**

5.4 RS-232 Remote Control Function

Example 13 : Outputs the data of memory A in ASCII format.

```
OPEN "COM1:9600,N,8,1,DS2000,LF" FOR RANDOM AS #1
DIM TR$(700)                                'Ensures 701 variables.

PRINT #1, "TAA?"                            'Specifies memory A (ASCII).
FOR I = 0 TO 700                             'Repeats data obtaining in 701 times.
    INPUT #1, TR$(I)
NEXT I
END
```

'Example result TR\$(0) = 0208 TR\$(1) = 0210 TR\$(699) = 0311 TR\$(700) = 0298

Example 14 : Outputs the data of memory B in binary format.

Opens the RS-232 port without insertion of the binary mode and the line feed character.

```
OPEN "COM1:9600,N,8,1,DS6000" FOR RANDOM AS #1

DIM TR$(1500)
CONST DLE = 16, STX = 2, EOT = 4
CONST CR = 13, LF = 10                    'Defines control character.

DLEflag = 0                              'Flag for DLE character deletion control
i = 3
PRINT #1, "TBB?; CHR$(CR); CHR$(LF);
TR$(1) = INPUT$(1, #1)                   'Receives DLE character.
TR$(2) = INPUT$(1, #1)                   'Receives STX character.
TR$(3) = INPUT$(1, #1)                   'Receives first byte of waveform data.
DO
    IF (DLEflag = 0) THEN                 'Detects DLE character in waveform
        IF (TR$(i) = CHR$(DLE)) THEN DLEflag = 1 ' data inserted.
    ELSE
        IF (TR$(i) = CHR$(DLE)) THEN
            DLEflag = 0                    'Deletes excess DLE character.
            i = i - 1
        ELSE
            IF (TR$(i) <> CHR$(EOT)) THEN DLEflag = 0
        END IF
    END IF
    i = i + 1
    TR$(i) = INPUT$(1, #1)                'Obtains waveform data.
```

**SPECTRUM ANALYZER
OPERATION MANUAL**

5.4 RS-232 Remote Control Function

(cont'd)

```
LOOP WHILE (NOT ((DLEflag = 1) AND (TR$(i) = CHR$(EOT)))) 'Detects end of data.
                                                    '(DLE and EOT characters)

STOP
END
```

Example 15 : Inputs the data of memory A in ASCII format.

```
DIM TR$(700)
OPEN "COM1:9600,N,8,1,DS6000,LF" FOR RANDOM AS #1

PRINT #1, "TAB"                                'Assumes that waveform data is already set to TR$( ).
FOR I = 0 TO 700
  PRINT #1, TR$(I)
  FOR J = 0 TO 10                               'Processing time is required at SPA.
    NEXT J
  NEXT I

STOP
END
```

Note: Set to VIEW mode before program execution. When VIEW key is pressed again after program execution, the input result will be confirmed.

**SPECTRUM ANALYZER
OPERATION MANUAL**

5.4 RS-232 Remote Control Function

Example 16 : Inputs the data of memory B in binary format.

Opens the RS-232 port without insertion of the binary mode and the line feed character.

```
OPEN "COM1:9600,N,8,1,DS6000,LF" FOR RANDOM AS #1

DIM TR$(1500)
CONST DLE = 16, STX = 2, EOT = 4      'Defines control character.
CONST CR = 13, LF = 10

PRINT #1, "TBB"; CHR$(CR); CHR$(LF);  'Assumes that data is already set to TR$( ) using "TBA?"
                                      'or "TBB?".

PRINT #1, CHR$(DLE); CHR$(STX);
FOR J = 0 TO 1401
  IF (TR$(J) = CHR$(DLE)) THEN
    PRINT #1, CHR$(DLE);
    FOR K = 0 TO 1                    'Wait time is required to ensure processing time at SPA.
    NEXT K
  END IF
  PRINT #1, TR$(J);
  FOR K = 0 TO 1                    'Wait time is required to ensure processing time at SPA.
  NEXT K
NEXT J
PRINT #1, CHR$(DLE); CHR$(EOT);

STOP
END
```

Note: Set to VIEW mode before program execution. When VIEW key is pressed after program execution, the input result will be confirmed.

(3) Status byte readout function

Since "Service Request (SRQ)" and "Status Byte" are GPIB-specific functions, the RS-232 does not support the same functions. However, the status byte readout function has been added to the RS-232 as part of normal message exchange. When the status byte data are read out by the status byte readout code (PLL?), the system sends out the data as two-byte ASCII data.

Table 5-9 Control codes for status byte

Message code	Content
PLL?	Requests the readout of status byte information from the system.
S2	Clears the status byte of the system (same as GPIB code).

Table 5-10 Status byte information

Bit	Decimal	Content
0	1	Sets to 1 when UNCAL occurs.
1	2	Sets to 1 when calibration is ended.
2	4	Sets to 1 when sweeping is ended.
3	8	Sets to 1 when average reaches the specified number of times.
4	16	Sets to 1 when plot output is ended.
5	32	Sets to 1 when an error occurs in the message code of this function.
6	64	Not defined
7	128	Not defined

Example of status byte data

Case for sweeping end and where average reaches the specified number of times. (4 + 8 = 12)

31	32	CR	LF
----	----	----	----

**SPECTRUM ANALYZER
OPERATION MANUAL**

5.4 RS-232 Remote Control Function

Example 17 : Reads out the end of average.

Example 17-1: For Quick BASIC

```
OPEN "COM1:9600,N,8,1,DS6000,LF" FOR RANDOM AS #1

PRINT #1, "S2"                ' Clears status byte.
PRINT #1, "AG 30GZ"          ' Start of average A (30 times)
SW:
  PRINT #1, "PLL?"           ' Reads out status byte.
  INPUT #1, StatusByte$
  SB = VAL(StatusByte$)
  IF (SB AND &H8) = 0 THEN GOTO SW ' Loops until third bit is set to 1.
PRINT "AVG. END"             ' Displays end.
END
```

Example 17-2: For N88-BASIC

```
10 OPEN "COM1:N83NN" AS #1
20 PRINT #1, "S2"
30 PRINT #1, "AG 30GZ"
40 *LOP1:
50   PRINT #1, "PLL?"
60   INPUT #1, S
70   IF (S AND 8)=0 THEN GOTO *LOP1
80 PRINT "AVG. END"
90 END
```

SPECTRUM ANALYZER
OPERATION MANUAL

5.4 RS-232 Remote Control Function

Example 17-3 : For HP-BASIC

```
20 !
30 ! *****
40 ! DO AVERAGING OPERATION THRU. SIO
50 ! *****
60 !
70 DIM Message(1)[130]
80 Sc=20
90 ON ERROR GOTO Error ! Set up error trap routine
100 GOSUB Sio_init
110 OUTPUT Sc;"S2"
120 OUTPUT Sc;"AG 30GZ"
130 L1: !
140 OUTPUT Sc;"PLL?"
150 ENTER Sc;S
160 IF BIT (S,3)<>1 THEN L1
170 PRINT "AVG. END"
180 STOP
190 !*****
200 ! ERROR HANDLING ROUTINE
210 !*****
220 Error: ! Error trap
230 IF ERRN<>167 THEN Other_error
240 STATUS Sc,10;Uart_error ! Get UART error information
250 IF BIT (Uart_error,2) THEN Overrun ! Overrun error
260 IF BIT (Uart_error,2) THEN Parity ! Parity error
270 IF BIT (Uart_error,2) THEN Framing ! Framing error
280 IF BIT (Uart_error,7) THEN Break ! Break detected
290 Other: ! Other error
300 PRINT "Other error !"
310 STOP
320 Overrun: ! Overrun error
330 PRINT "Overrun error !"
340 STOP
350 Framing: ! Framing error
360 PRINT "Framing error !"
370 STOP
380 Break: ! Break
390 PRINT "Break detected !"
400 STOP
410 Other_error: ! NO ERROR
420 PRINT "Error trapped ?"
430 STOP
440 !*****
450 ! SERIAL COMMUNICATION I/F INITIALIZE
460 !*****
```

**SPECTRUM ANALYZER
OPERATION MANUAL**

5.4 RS-232 Remote Control Function

(cont'd)

```

470 Sio_init:                                ! Initialize SIO Control reg.
480         CONTROL Sc, 0;1                  ! Reset I/F board
490         CONTROL Sc, 3;1                  ! Set PROTOCOL TO Async.
500 Wait:  STATUS Sc, 38;All_sent
510         IF NOT All_sent THEN Wait
520         CONTROL Sc, 0;1                  ! Reset I/F Card
530         CONTROL Sc, 14;1+2+4            ! Set Control Block Mask
540         ! CONTROL Sc, 39;4              ! Set Break signal time
550         ! CONTROL Sc, 6;1              ! Break signal send
560         CONTROL Sc, 8;3                  ! Set DTR/RTS line
570         CONTROL Sc, 13;128+1           ! Set INT mask
580         CONTROL Sc, 15;0                ! No modem time-change notification
590         CONTROL Sc, 16;0                ! Disable connection time out
600         CONTROL Sc, 17;0                ! Disable nonactivity time out
610         CONTROL Sc, 18;40               ! Lost Carrier 400 ms
620         CONTROL Sc, 19;10              ! Transmit time out 10S
630         CONTROL Sc, 20;15              ! Set Transmit speed : 19200
640         CONTROL Sc, 21;15              ! Set Receive speed : 19200
650         CONTROL Sc, 22;0                ! Set protocol handshake to non
660         CONTROL Sc, 23;3                ! Set H/W handshake type
670         CONTROL Sc, 24;2
680         CONTROL Sc, 28;2                ! Set EOL chra. NO.
690         CONTROL Sc, 29;13              ! Set CR code
700         CONTROL Sc, 30;10              ! Set LF code
710         CONTROL Sc, 34;3                ! Set DATA LENGTH 8 BIT
720         CONTROL Sc, 35;0                ! Set STOP BIT TO 1 BIT
730         CONTROL Sc, 36;0                ! Set PARITY TO NON
740         CONTROL Sc, 37;0                ! Set CHAR. INTERVAL
750         RETURN
760     !!!!!
770     END

```

Example 18 : Intermittently reads out the end of single sweeping.

```

OPEN "COM1:9600,N,8,1,DS6000,LF" FOR RANDOM AS #1

PRINT #1, "SI"                               ' Sets to SINGLE.
PRINT #1, "S2"                               ' Clears status byte.
PRINT #1, "SR"                               ' Start of sweeping
SW:
    PRINT #1, "PLL?"                          ' Reads out status byte.
    INPUT #1, StatusByte$
    SB = VAL(StatusByte$)
    IF (SB AND &H4) = 0 THEN GOTO SW          ' Loops until second bit is set to 1.
PRINT "SWEEP END"                             ' Displays end.
END

```

Example 19 : Outputs the marker frequency and the level simultaneously (Xon/Xoff control).

Example 19 is a modification of Ex. 10 and shows the case where the "Xon/Xoff" control is selected as the data flow control.

Opens the RS-232 port with the specifications as follows:

- Transmission speed: 9600 bps
- Parity: none
- Data length: 8 bits
- Stop bit: 1 bit
- ASCII mode (for Xon/Xoff control)
- Line feed character insert mode
- DSR line monitor timeout time: 6 s

```

OPEN "COM1:9600,N,8,1,ASC,DS6000,LF" FOR RANDOM AS #1

PRINT #1, "HD0"                'Header output prevention
PRINT #1, "MFL?"
INPUT #1, Mf$, M1$
Mff = VAL(Mf$)                 'Example result  Mff = 1.8E + 09 M11 = -73.02
M11 = VAL(M1$)
END
```

(4) Panel key lock function

The GPIB remote control uses a "remote/local enable" function to inhibit local operation. The RS-232 remote control achieves the same result by sending a message. This is called the panel lock function. Once a request for the panel lock has been sent by the controller to the system, key and knob operation on the panel of the system is inhibited until the controller sends a panel unlock message or a local message (LC). However, the panel lock condition can be canceled by any of the following operations:

- Pressing the LCL key
- Pressing the IP key
- Switching off the power to the system

In addition, when in the panel lock condition, the system cannot change the softmenu on the screen using commands from the controller.

Table 5-11 Control codes for status byte

Message codes	Content
KLK	Inhibits the key operation on the panel of the system (panel lock).
KUK	Permits the key operation on the panel of the system (panel unlock).

5.4.6 Data Communication Errors

A communication error (such as timeout) may occur for some reason at the controller during RS-232 remote programming execution. To improve the reliability of remote operation in such cases, the final message (command) sent from the controller can be retransmitted. This section shows an example of a simple recovery program using Microsoft's "Quick BASIC".

Example 20 : Using NEXT PEAK, reads out the 10 peak levels from the second peak level of a signal. (This example is Ex. 12 with communication error processing added.)

```

CONST CommTimeOut = 24           'Timeout error No.
CONST CommBuffOver = 69         'Buffer overflow error No.

DIM M1$(9), M11(9)
OPEN "COM1:9600,N,8,1,DS6000,LF" FOR RANDOM AS #1
ON ERROR GOTO Commerror

PRINT #1, "PS"
FOR I = 0 TO 9
    PRINT #1, "NXP"
    PRINT #1, "ML?"
    INPUT #1, M1$(I)
NEXT I
STOP                               'Example result  M11(1)=-55.01 M11(2)=-58.22 ..
                                   'Communication error processing routine

Commerror:
    IF ERR = CommTimeOut THEN
        IF RetryCount = 5 THEN
            ON ERROR GOTO 0
        END IF
        RetryCount = RetryCount + 1
        PRINT "Communication TIME OUT !!!"
        FOR J = 0 TO 5000
            NEXT J
        PRINT "Retry communication !?"
        RESUME
    ELSE
        IF ERR = CommBuffOver THEN
            PRINT "Communication buff. overflow !!!"
            RESUME
        END IF
        PRINT "Something Error has been occurred."
        PRINT "Error no. : " ; ERR
        ON ERROR GOTO 0
    END IF
END

```

5.4.7 Exceptional Processing

If any of the following conditions arises in the system, it will suspend the communication at that time and perform the following as exceptional processing.

- (1) Conditions : The next character is not received within 5 seconds of the last received character during message receiving from the controller (before receiving the delimiter character string).

Processing : The system cancels that message and generates a break signal. It will use the next received character as the start of message.

- (2) Condition : During message transmission to the controller, transmission prevention is not canceled from the controller more than 5 seconds between the sending of the last character and the sending of the next character.

Processing : The system suspends the message transmission and is ready for the next transmission/reception.

- (3) Condition : When the trace data are input, the system cannot detect the transmission from the controller for more than 25 seconds while the specified number of bytes (for ASCII format) or specified number of bytes (for binary format) has not been reached.

Processing : The system will cancel the input mode for the trace data and is ready for the next transmission/reception.

- (4) Condition : When messages are received, a framing error, parity error, or overrun error occurs.

Processing : The system will cancel the message and generate a break signal. It will use the next received character as the start of the message.

6. MEASUREMENT METHOD

This chapter shows how to use the analyzer by explaining example measurement procedures.

Note : Unless specified, U3641 is used in the example of the measurement.

6.1 Common Detailed Informations to All Measurements

6.1.1 Input Frequency Range and Resolution

The analyzer is capable of analyzing input signals with frequencies ranging from 9 kHz to 3 GHz. However, even for frequencies within this range, if the resolution and sweep time etc. are not set properly, accurate measurements may not result.

Analysis parameters are set with CPL key. This chapter describes the setting of the resolution bandwidth, the video bandwidth, the sweep time, and the input attenuator.

(1) Resolution bandwidth (RBW)

The frequency resolution of a spectrum analysis is specified in terms of its resolution bandwidth. This is the frequency bandwidth where the level has dropped 3 dB from the peak wave specified. With the analyzer, the RBW can be set from 100 Hz to 3 MHz and WIDE RBW (at Zero span). (However, 100 Hz and 300 Hz are optional.)

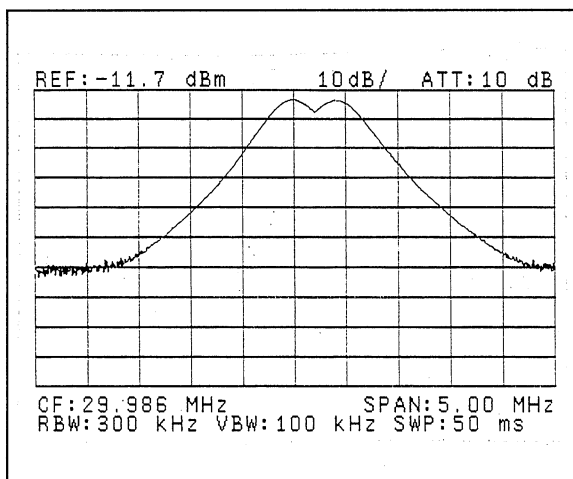

Figure 6-1 Using the largest possible IF bandwidth that two signals can be resolved

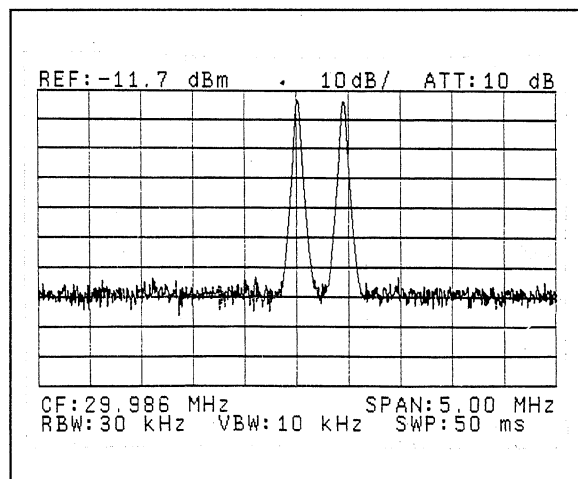

Figure 6-2 Using a very narrow RBW that two signals are completely separated

**SPECTRUM ANALYZER
OPERATION MANUAL**

6.1 Spectrum Analyzer Parameters Common to All Measurements

When the resolution bandwidth is set to be very narrow, the resulting spectrum is also very fine in detail and has increased the resolution of the spectrum. (See Figure 6-2.) Thus it is possible to separate a signal from neighboring noise, or two closely spaced spectral components. But as the resolution bandwidth is decreased it takes an increasing amount of time to sweep through the same frequency range. If the sweep speed is too fast, the signal level measured at each frequency drops, and an "UNCAL" message appears on the display.

(2) Video bandwidth (VBW)

By averaging the noise riding on input signal and bottom noise on display, video bandwidth has the effect of finding true signal that was buried with noise.

The VBW of the analyzer can be set between 10 Hz and 3 MHz.

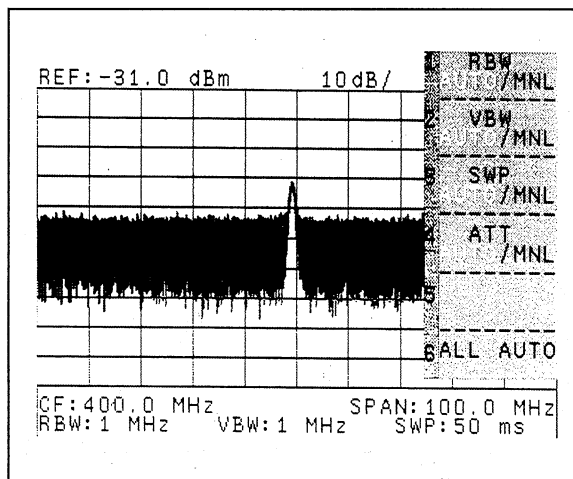

Figure 6-3 VBW = 1 MHz

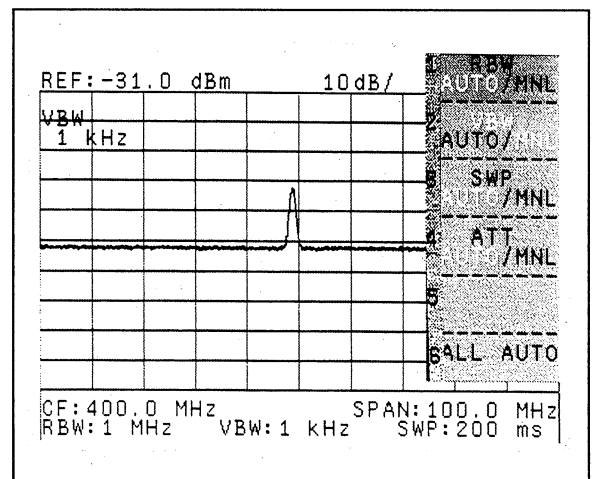

Figure 6-4 VBW = 1 kHz

Noise averaging is done by the low pass filter filtering the signal from the detector, so an approximately 10 dB improvement in S/N can be obtained.

To do this noise averaging most effectively, the video bandwidth must be chosen based on the resolution bandwidth setting. (In general 1/10 or less of the RBW is desirable.)

If the VBW is set too narrowly, because of the filter time constant the spectral levels measured will decrease from their true values.

To warn of this, the UNCAL message will appear on the display. In such a case, increasing the sweep time will allow the chosen VBW to be used accurately.

**SPECTRUM ANALYZER
OPERATION MANUAL**

6.1 Spectrum Analyzer Parameters Common to All Measurements

(3) Sweep time (SWP)

The sweep time is the amount of time required to sweep through the frequency span requested. The sweep time of the analyzer can be set between 50 msec and 1000 sec. (The sweep time can be set in the range of 50 μ sec to 1000 sec in the zero span mode.)

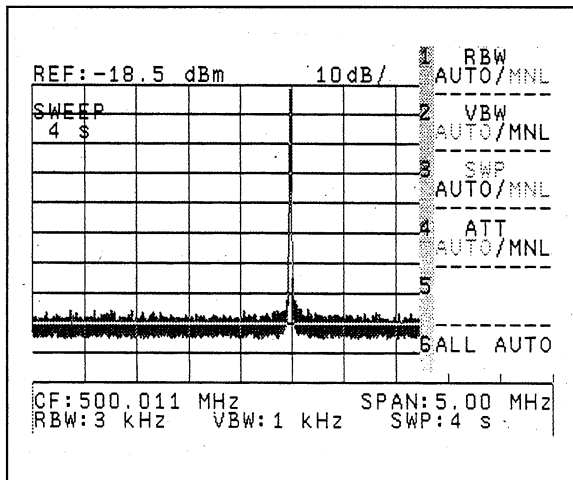

Figure 6-5 SWP = 4 s

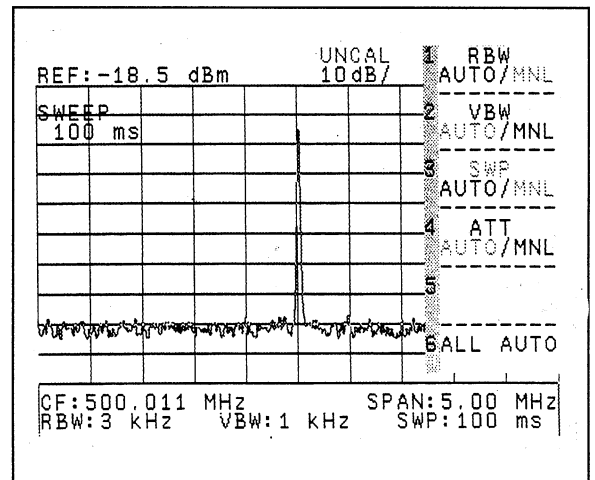

Figure 6-6 SWP = 100 ms

If the sweep speed is too fast, the signal processing will not be able to keep up with it. To prevent any unexpected error in the levels displayed in the spectrum, the "UNCAL" message will appear in the center of the upper screen. In that case it is necessary to increase the sweep time.

(4) Input attenuator (ATT)

The attenuator is used to protect the analyzer input section from damage; to attenuate the input signal amplitude to a level where it can be measured easily; and finally to reduce undesirable distortions which could affect measurements. The analyzer attenuator can be set between 0 to 50 dB in 10 dB steps.

6.1.2 Maximum Input Level and Dynamic Range

(1) Maximum input level

The inputtable maximum signal level is shown in Table 6-1.

If the signals exceeding the maximum input level shown in Table 6-1 are present in the system, be sure to decrease the input level by using the attenuator.

**SPECTRUM ANALYZER
OPERATION MANUAL**

6.1 Spectrum Analyzer Parameters Common to All Measurements

CAUTION

If a signal exceeding the maximum input level shown in Table 6-1 to RF input of the analyzer, the internal input protection circuit cause the input signal to interrupt automatically and display an OVERLOAD. In this case, reduce the input signal levels less than +20 dBm immediately.

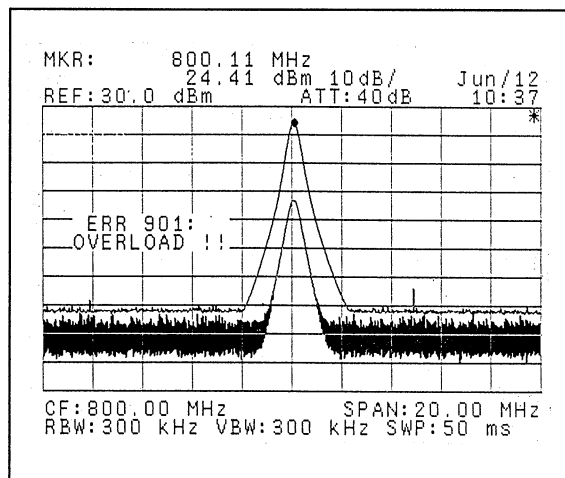

OVER LOAD Display

Table 6-1 Maximum input level

Max. input level	U3641/3641PHS	U3641N	Remarks
Preamplifier OFF	+27 dBm ± 50 V _{DCmax}	+134 dB _μ V ± 50 V _{DCmax}	Input attenuator ≥ 10 dB
Preamplifier ON	+13 dBm ± 50 V _{DCmax}	+120 dB _μ V ± 50 V _{DCmax}	

(2) Dynamic range

If the input attenuation is set incorrectly and an excessive large signal is input, the input mixer can saturate. Or if two or more signals with closely spaced frequencies are input, again the input mixer can give rise to (spurious) intermodulation distortion.

In either case, accurate signal analysis will become impossible. The range of input levels over which accurate analysis is possible is called the analyzer's "dynamic range". In other words, the dynamic range is the difference (in dB) between the level of the largest signal and the smallest signal that both can be displayed at the same time, with no spurious signals produced by distortion etc. appearing.

The dynamic range is determined by the following four items:

**SPECTRUM ANALYZER
OPERATION MANUAL**

6.1 Spectrum Analyzer Parameters Common to All Measurements

- Average display noise level
- 1dB gain compression point
- Spurious response
- Residual response

The above four items therefore limits the measurement dynamic range. It is important to be able to decide which factor has the largest influence in any given situation.

For example, when measuring spurious signals due to distortion etc., the input attenuator should be set as large as possible in order that the mixer input level be as small as possible. However, depending on the extent that the attenuation is increased, the input sensitivity will be decreased.

When the distortion level to be measured is much larger than the analyzer internal distortion then there is especially no particular problem; however, to measure distortion levels similar to or even much smaller than the analyzer distortion level, it is necessary to use a filter or other means to remove the fundamental frequency from the input signal. Supposing that the fundamental could have been removed, the maximum input sensibility can be used to measure the signal source distortion since only the distortion level of the signal source is input. But even in that case it is necessary to consider the effects of the residual response on the measurement. In order to obtain the largest dynamic range in normal signal analysis it is necessary to set the reference level to be at the maximum peak level of the input signal.

Average display noise level

This is a measure of the maximum input sensitivity. The input sensitivity is related to the noise internally generated by the analyzer itself, and depends on the resolution bandwidth used. Normally it is determined by the average noise level of the analyzer at its narrowest resolution bandwidth ; it determines the dynamic range lower limit.

The average display noise level is shown in table 6-2.

Table 6-2 Average display noise level

Avg. display noise level	U3641/3641PHS	U3641N	Remarks
Preamplifier OFF	- 117 dBm + 2.7f (GHz) dB	- 8 dB μ V + 2.7f (GHz) dB	RBW 1kHz, VBW 10 Hz, INPUT ATT 0 dB, and frequency of 1 MHz or more
Preamplifier ON	- 135 dBm + 4.3f (GHz) dB	- 22 dB μ V + 3.0f (GHz) dB	

1 dB gain compression point

This is a measure of the linear input range. When the level of the signal input to the mixer is increased above a certain value, the mixer starts to saturate. From that point on the mixer output IF signal no longer tracks the input signal amplitude. The result is that the level displayed on the screen didn't show the accurate value.

The input level at which there is a 1 dB decline (compression) from the ideal response characteristic is defined to be the 1 dB gain compression point.

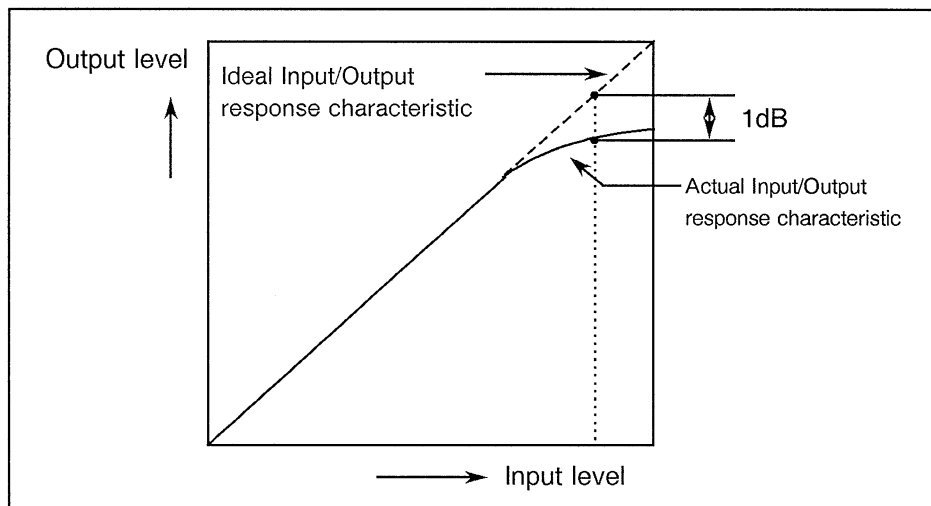

Figure 6-7 1 dB gain compression point

Since gain compression is a error factor in making normal signal level measurements, the 1 dB gain compression point effectively sets the upper limit to the dynamic range.

Thus it is necessary to use the attenuator in order to control the amplitude of the signal applied to the input mixer (mixer input level) so that gain compression will not occur when making level measurements.

The 1 dB gain compression level for the analyzer is shown in Table 6-3.

Table 6-3 1 dB gain compression (Frequency 10 MHz or more)

1 dB gain compression	U3641/3641PHS	U3641N	Remarks
Preamplifier OFF	> - 10 dBm	> + 100 dB μ V	Mixer input level
Preamplifier ON	> - 40 dBm	> + 80 dB μ V	RF input level

**SPECTRUM ANALYZER
OPERATION MANUAL**

6.1 Spectrum Analyzer Parameters Common to All Measurements

When making level measurements, input attenuator or external attenuator must be set to keep the mixer or RF input below the level shown in Table 6-3.

Example: Measuring 0 dBm input signal.

Input attenuator set to 10 dB

In case, the input level at the mixer would be -10 dBm; gain compression would be occurring and then the accuracy of the level measurement would be compromised.

Input attenuator set to greater than 20 dB

In this case the input level at the mixer would be less than -20 dBm; there would be no gain compression. But on the other hand, the greater the input attenuation the worse the S/N would become. Therefore, for simply measuring signal levels the attenuator should be set to the smallest value.

Spurious response

Whenever a signal is applied to the input mixer, harmonic distortion necessarily occurs due to the mixer non-linearity. This analyzer generated harmonic distortion is an important error factor in distortion measurements; and sets the ultimate limit in distortion measurements possible with the analyzer. In the typical spectrum analyzer it is the second order harmonic and third order intermodulation distortions that create spurious response problems.

Second order harmonic distortion

When, an absolute pure signal with no harmonic component is applied to the analyzer, some harmonic spectral component that must be being generated inside the input mixer appears in the display.

The ratio of these harmonic signal to the fundamental frequency level is defined as second order harmonic distortion. Usually the problem is the appearance of a harmonic at twice the frequency of the fundamental. The second order harmonic distortion for the analyzer is shown in Table 6-4.

SPECTRUM ANALYZER
OPERATION MANUAL

6.1 Spectrum Analyzer Parameters Common to All Measurements

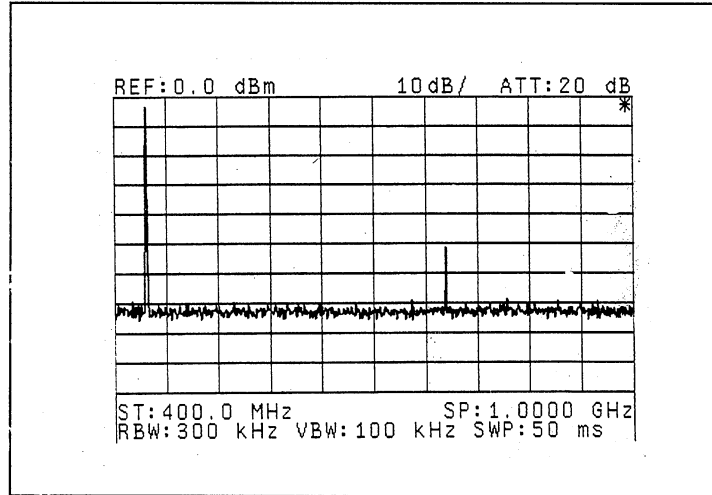

Figure 6-8 Second order harmonic distortion

Third order intermodulation distortion

When two signals (with frequencies f_1 , f_2) are applied to the spectrum analyzer, intermodulation occurs in the input mixer and new spurious signals with frequencies of $2f_1 - f_2$ and $2f_2 - f_1$ are created. These are the third order intermodulation distortion, and the ratio of their level to the fundamental is used to quantify the distortion. In the analyzer when the level of the fundamental is -30 dBm at the mixer input the third order intermodulation distortion is guaranteed to be below -70 dB.

The third order intermodulation distortion for the analyzer is shown in Table 6-4.

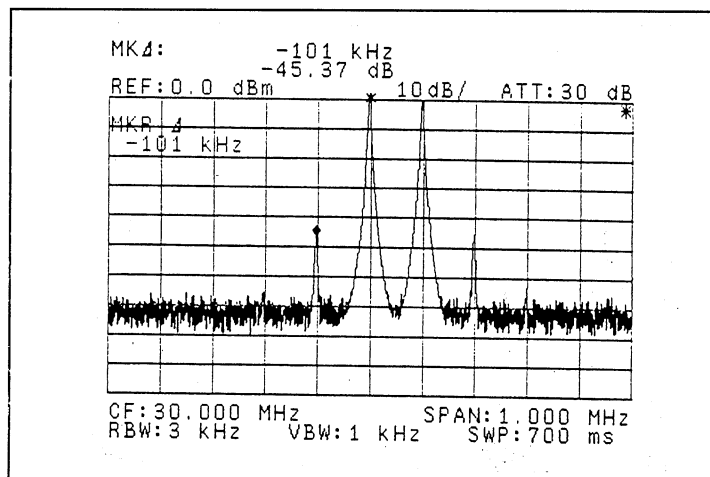

Figure 6-9 Third order intermodulation distortion

**SPECTRUM ANALYZER
OPERATION MANUAL**

6.1 Spectrum Analyzer Parameters Common to All Measurements

Table 6-4 Spurious response

Second order harmonic distortion and third order intermodulation distortion	U3641/3641PHS	U3641N	Remarks
	- 70 dB or less (in - 30 dBm input)	- 70 dB or less (in + 78 dB μ V input)	Input attenuator of 0 dB and frequency of 10 MHz or more Amplifier OFF

Residual response

Residual response is the name for those spurious responses that are generated inside a spectrum analyzer by leakage from the local oscillator, or other specific internal signal sources, even when no signal for analysis is applied. Residual response is important when analyzing extremely small signals.

The residual response for the analyzer is shown in Table 6-5.

Table 6-5 Residual response

Residual response	U3641/3641PHS	U3641N	Remarks
Amplifier OFF	- 100 dBm or less	+ 10 dB μ V or less	Input attenuator : 0 dB frequency : 1 MHz or more
Amplifier ON	- 105 dBm or less	+ 5 dB μ V or less	U3641 : Input terminal of 50 Ω U3641N : Input terminal of 75 Ω

6.2 Frequency Measurement

There are two methods for making a frequency measurement: the normal marker and the frequency counter mode method. In this section, the frequency measurement is performed when the signal source is approximately 30 MHz.

6.2.1 Normal Marker Frequency Measurement

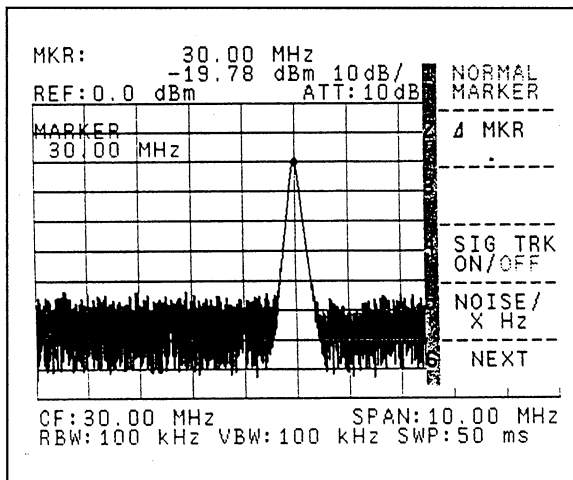
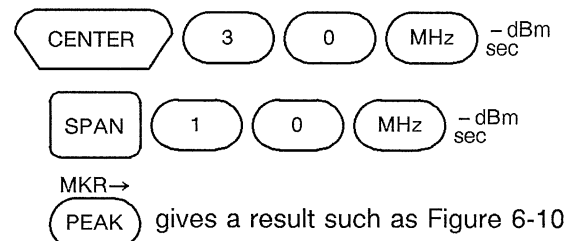

Figure 6-10 Normal marker Measurement

Pressing the following keys:



The marker frequency is displayed at the top left of the screen.

6.2.2 Frequency Counter Mode Frequency Measurement

Make frequency measurements with the frequency counter mode for more accurate measurements. The frequency counter mode measures the marker's existing signal frequency at the direct standard oscillator accuracy (1×10^{-5} for the analyzer) and is different from the frequency measurement with normal marker mode.

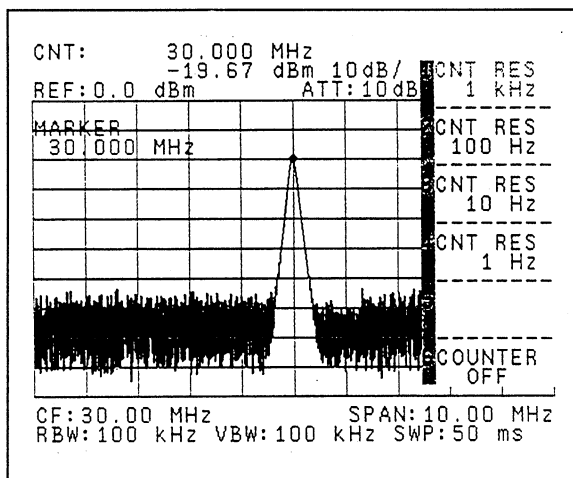
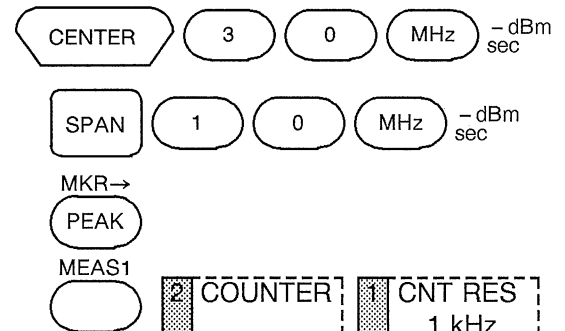

Figure 6-11 Frequency counter Measurement

Pressing the following keys:



Press the keys in order and set the frequency resolution to 1 kHz.

The waveform shown in Figure 6-11 is gained and at the upper left we see the counter frequency measured at the 1 kHz resolution.

CAUTION

1. Frequency Counter mode can measure correctly when the signal peak level to be measured in the $1\text{ kHz} \leq \text{span} \leq 200\text{ MHz}$ and $\text{RBW} \geq 3\text{ kHz}$ is 25 dB or more from the noise level. When the span or the RBW is set out of the above range, the CNT display blinks. It shows the counter cannot be normally operated under these conditions.
2. When spectrum is too narrow, counter miss count happens.
RBW setting is better to be set AUTO.
3. If more accurate measurements are required, connect the 10 MHz reference signal source of the external device to the 10 MHz reference signal input terminal of the analyzer rear panel.
In this case, the measurement accuracy is set to the 10 MHz reference signal of the external device connected. The 10 MHz reference signal input range of the analyzer is circumscribed within 0 dBm to +16 dBm. Also set to use the external device for the 10 MHz signal source of the analyzer.

Press    NEXT  10M REF EXT/INT and set the 10M REF to EXT.
(See section 7.8.5.)

6.3 Level Measurement

The U3641/3641PHS is used at the input impedance of $50\ \Omega$, dBm unit and the U3641N of $75\ \Omega$, dB μ V unit.

6.3.1 Second Order Harmonic Distortion Measurement

Example is the measurement when the second order harmonic distortion level is small.

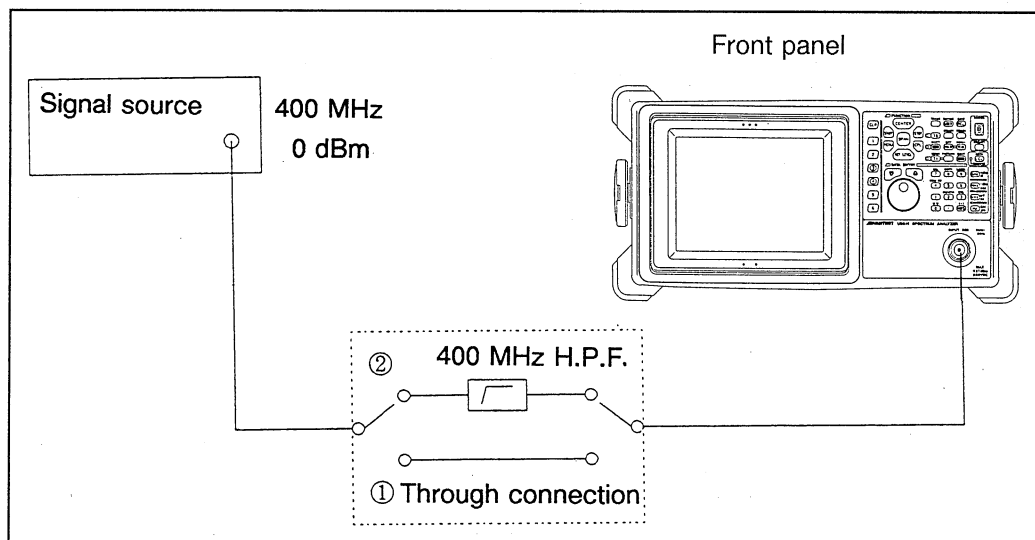

Figure 6-12 Connection of second order harmonic distortion measurement

- (1) First measure the level of the fundamental frequency introduced from the signal generator by making the direct connection as shown Figure 6-12.

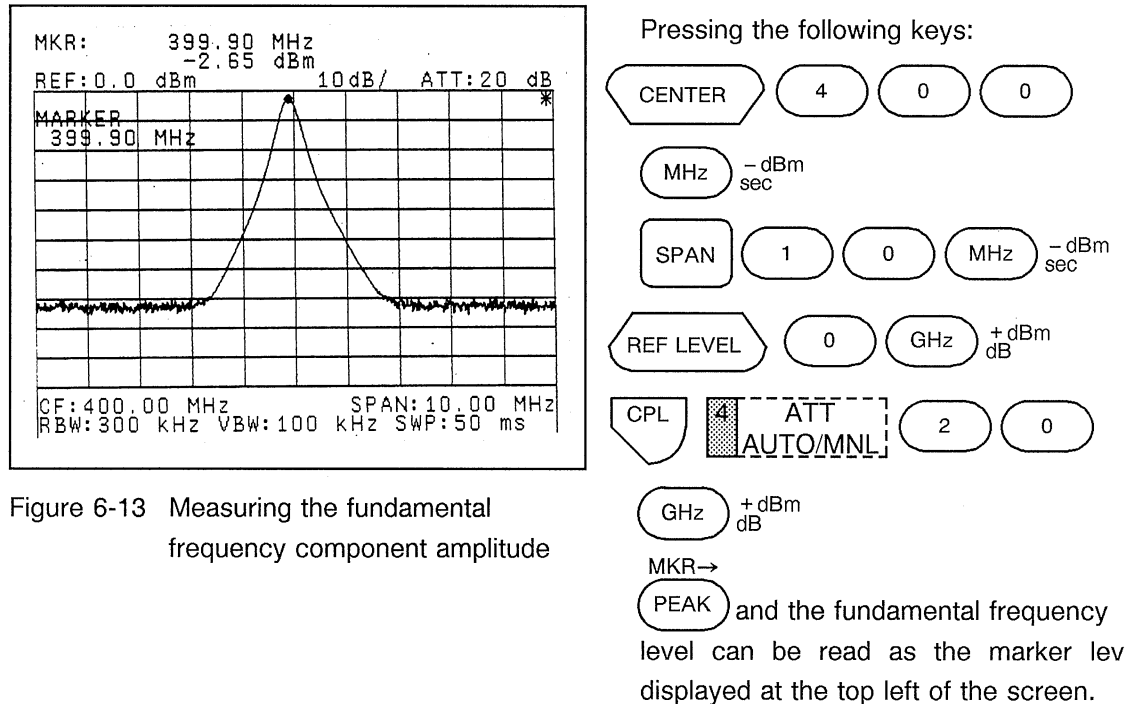

Figure 6-13 Measuring the fundamental frequency component amplitude

- (2) Next insert a 400 MHz high pass filter (HPF) into the analyzer input in order to cut off the fundamental frequency component. (Figure 6-12. switch position 2). If the second order harmonic distortion of the signal generator is sufficiently greater than the analyzer's distortion level then the high pass filter may not be necessary. But if the signal source has a clean output, or you wish to make the most accurate measurements possible, then always use the HPF between the source and the spectrum analyzer in order to suppress the effects of any harmonic distortion from the analyzer.

Pressing the following keys:

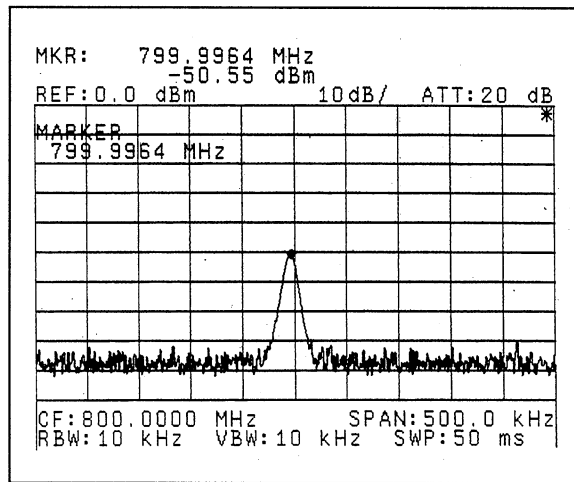

Figure 6-14 Second order harmonic distortion measurement

CENTER 8 0 0

MHz - dBm
sec
Press CPL [4] ATT AUTO/MNL

and set the ATT to AUTO.

Press REF LEVEL and set the fundamental level to the optimize position for observing the waveform by using the step keys.

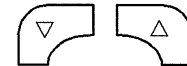

In very small signal cases where the harmonic spectrum is buried under the noise level, try using a higher frequency resolution, or averaging noise by narrowing the video bandwidth.

Now the analyzer is set up to measure the level of the harmonic signal, press MKR→ PEAK and read marker level displayed at the top left of the screen as the second order harmonic distortion level. The second order, harmonic distortion is just the difference in dB between the fundamental frequency component level measured in the previous step and the current marker level.

6.3.2 Third Order Intermodulation Distortion Measurement

Example is third order intermodulation distortion measurement in 20 dB gain amplifier.

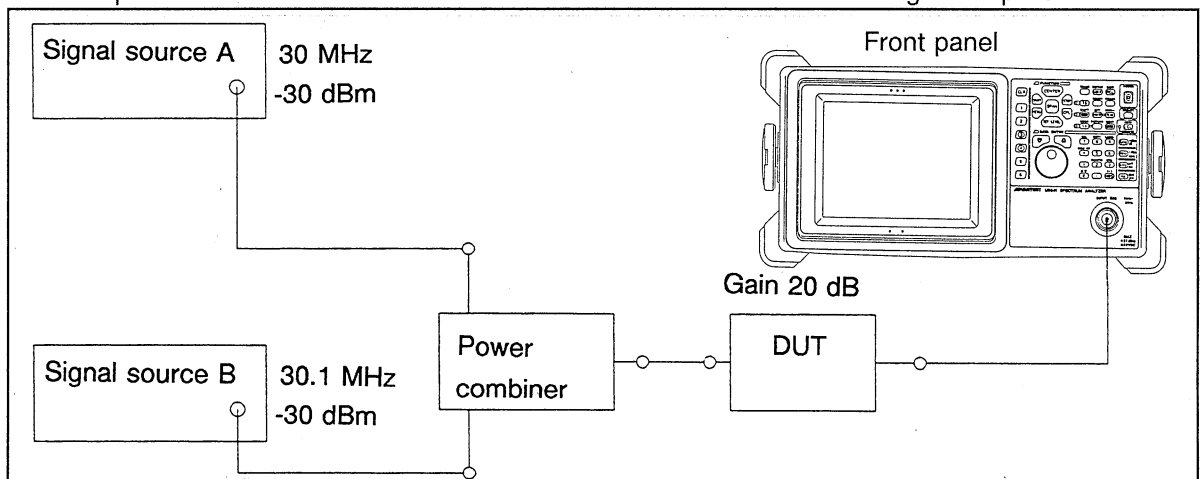
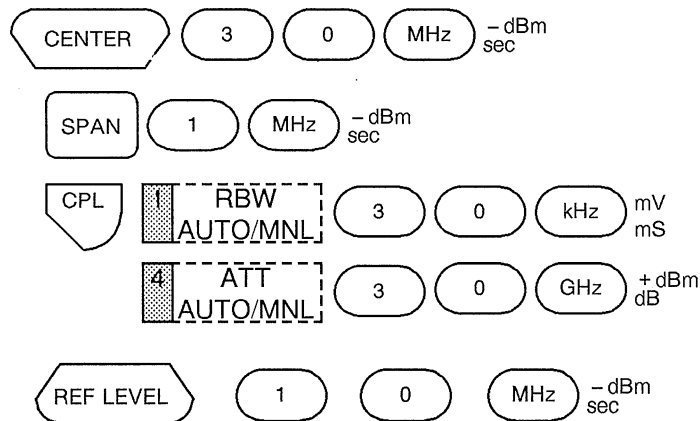

Figure 6-15 Third order intermodulation distortion measurement

**SPECTRUM ANALYZER
OPERATION MANUAL**

6.3 Level Measurement

- (1) As shown in Figure 6-15, begin by connecting two signal generators A and B by a power combiner. The two signals (30 MHz and 30.1 MHz) are then passed through a 20 dB gain amplifier under test to the input of the analyzer.
- (2) Pressing the following keys:



Adjust the output level of the signal source A and B, so that two signal peak levels on the screen are equal with the reference level.

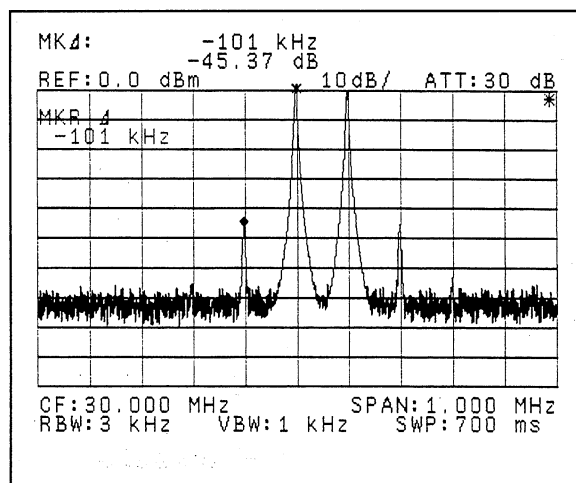



Figure 6-16 Third order intermodulation distortion

- (3) Press MEAS2 2 3rd ORD
MEAS.

By pressing the keys in order, the Δ marker display appears and start the measurement for the third order intermodulation distortion. We see the measurement result on the upper left of the screen as shown in Figure 6-16.

6.3.3 Measuring Small Signal Level

The analyzer incorporates the pre-amplifier with the gain of 20 dB or more at frequency width range of 9 kHz to 2.2 GHz. Therefore the input sensibility increases and the very minute level signal of -130 dBm or less can be analyzed. Also a gain don't need to be considered at level measurement since the level frequency characteristic at pre-amplifier operating is calibrated before shipping.

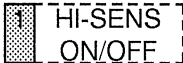
Press   and set the HI-SENS to ON.

The pre-amplifier starts, and the input attenuator is automatically set to 0 dB when the input attenuator is set to AUTO. The reference level is set according to the pre-amplifier OFF setting.

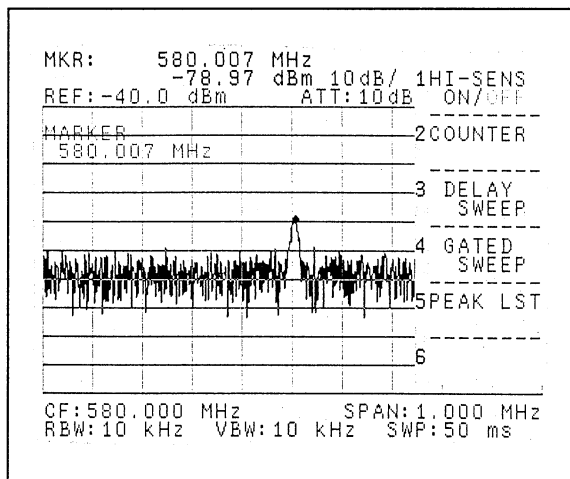

Figure 6-17 Pre-amplifier OFF

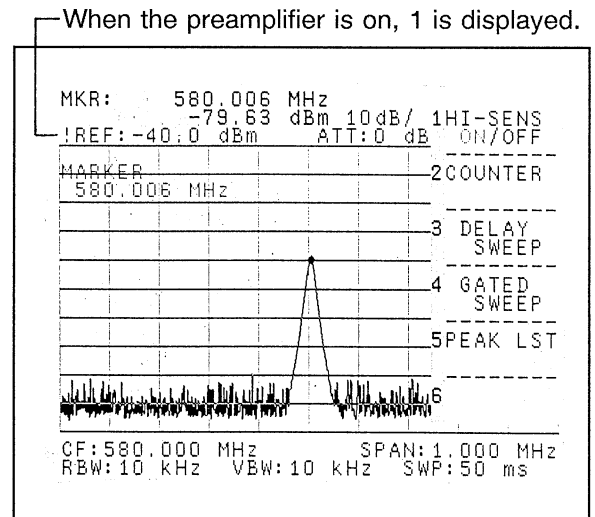

Figure 6-18 Pre-amplifier ON

CAUTION

1. The 1 dB gain compression level at pre-amplifier operating is -40 dBm for U3641 and U3641PHS (70 dB μ V for U3641N). If over -40 dBm is input, the level measurement cannot be performed correctly due to the signal distortion in the pre-amplifier portion.
2. The maximum allowable input level at pre-amplifier operating is +13 dBm for U3641 and U3641PHS (+120 dB μ V for U3641N), and ± 50 V_{DC} for DC coupling. If the signals exceeding the maximum input level are input, it may result in damage to the pre-amplifier.

6.4 Modulation Signal Measurements

These sections cover measurements of AM, FM and Pulse Modulated signals using the analyzer. Unless mentioned, the carrier frequency is 400 MHz for all the examples.

6.4.1 AM Signal Analysis

For measuring residual AM or FM as weakly as modulated signals, the spectrum analyzer working in the frequency domain can do more excellent perform as compare with the oscilloscope working in the time domain.

In the time domain the AM Modulation Index m is given by:

$$m (\%) = \frac{E_{max} - E_{min}}{E_{max} + E_{min}} \times 100$$

(See Figure 6-19(a))

But with a spectrum analyzer, all that is needed is to measure how many dB the sideband signals are below the carrier signal level. (See Figure 6-19(b))

At the same time, the modulation factor for other higher harmonics of the modulating signal can be easily measured. In particular, when the modulation is weak, only about a 2% accuracy can be obtained in time domain measurements, but with a spectrum analyzer accuracies of 0.02% are possible.

When the modulation index is above 10%, best accuracy can be obtained by making the measurement with LINEAR scaling. For modulation indexes below 10% better measurement accuracy can be achieved by selecting LOG scales. The analyzer is newly added an AM modulation accuracy function. Using this new function, an easy operation can be made to obtain an AM modulation accuracy.

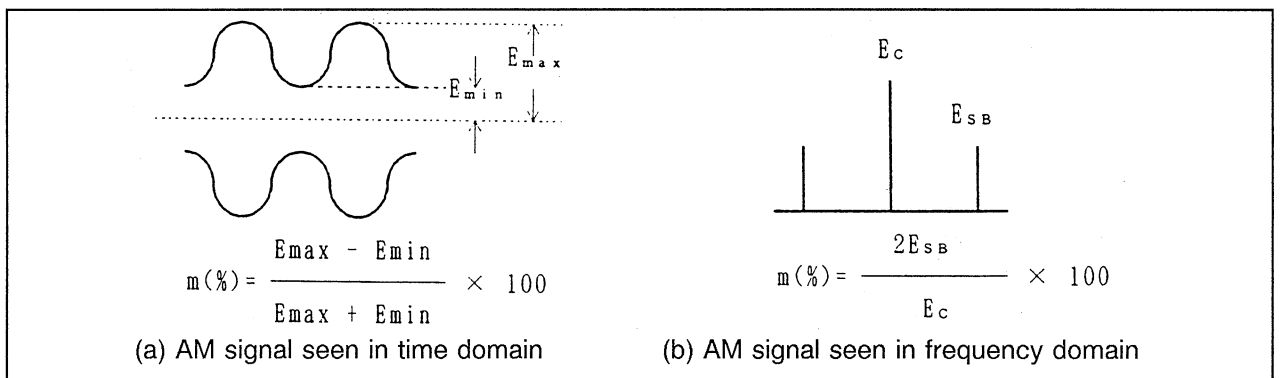

Figure 6-19 AM signal measurement

**SPECTRUM ANALYZER
OPERATION MANUAL**

6.4 Modulation Signal Measurements

(1) Example is a measurement by Time Domain (Low modulation frequency and large modulated AM frequency).

- ① Display the signal to be measured (400 MHz carrier freq.), and set its peak level to the reference level:

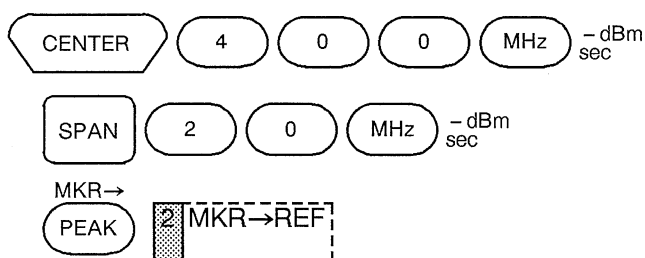

- ② Put the horizontal axis into the time domain mode (Zero span), the vertical axis into LINEAR mode, and detector into SAMPLE mode.

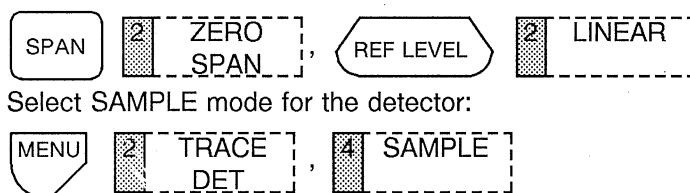

Select SAMPLE mode for the detector:

- ③ Set the resolution bandwidth to be greater than 3 times the modulation frequency:



- ④ Move the reference level to the peak level of the signal:

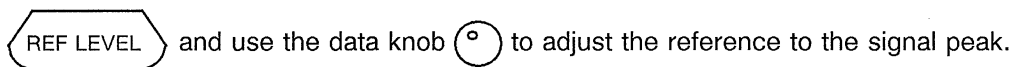

- ⑤ Set the Trigger mode to Video Trigger, and the sweep time to an appropriate value:

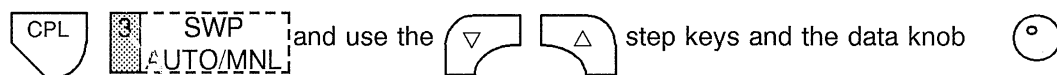
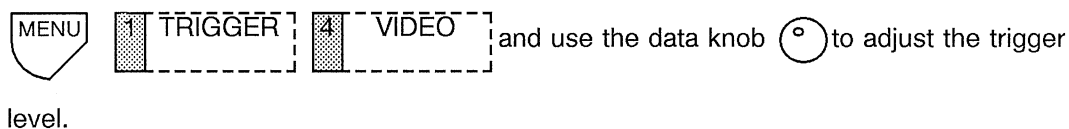

to adjust the sweep time to see a full modulation cycle.

**SPECTRUM ANALYZER
OPERATION MANUAL**

6.4 Modulation Signal Measurements

- ⑥ Use the AM modulation frequency function to measure the AM modulation accuracy.

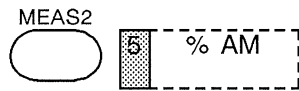

△ Marker can be displayed and the AM modulation accuracy is displayed in the marker area. (See Figure 6-20.)

- ⑦ The modulation frequency can be found by using the Δmarker to measure the distance between modulation peaks (the period). The modulation frequency is just the inverse of the period.



and then use the data knob (◉) to move the marker to

the next peak.



to ON. The modulation frequency is read off from the top of the display. (see Figure 6-21.)

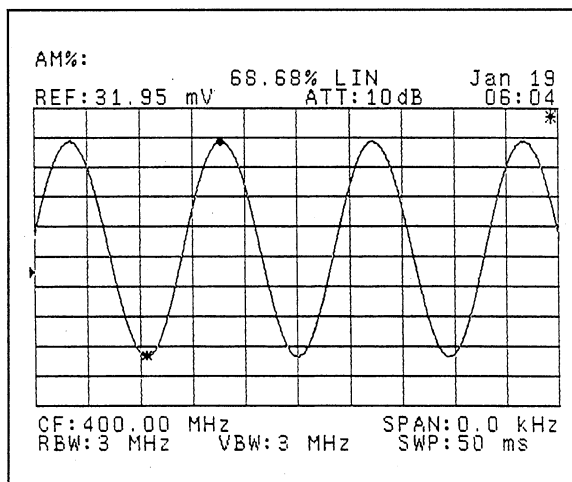

Figure 6-20 AM modulation index

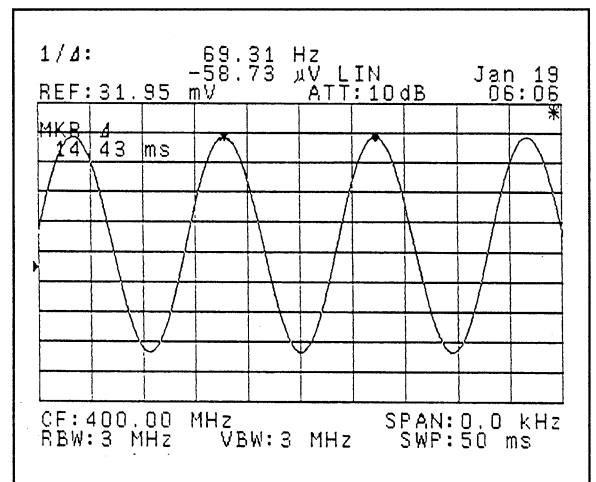
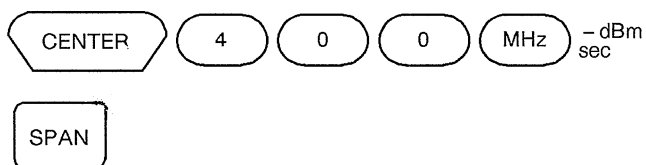

Figure 6-21 Modulation frequency of an AM signal

(2) Example is a measurement by frequency domain. (high frequency modulation and small modulation index m.)

- ① Set the center frequency to the AM carrier frequency, and the frequency span for a clear display of the sidebands:



and use the step keys to adjust the span to be greater than twice, and less than 10 times the modulation frequency.

- ② Use the AM modulation frequency function to measure the AM modulation accuracy.

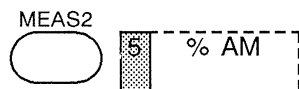

The AM modulation accuracy is displayed in the marker area. (See Figure 6-22.)

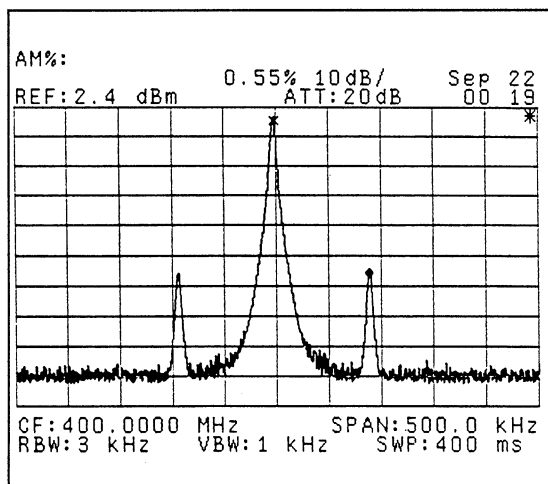

Figure 6-22 AM modulation accuracy

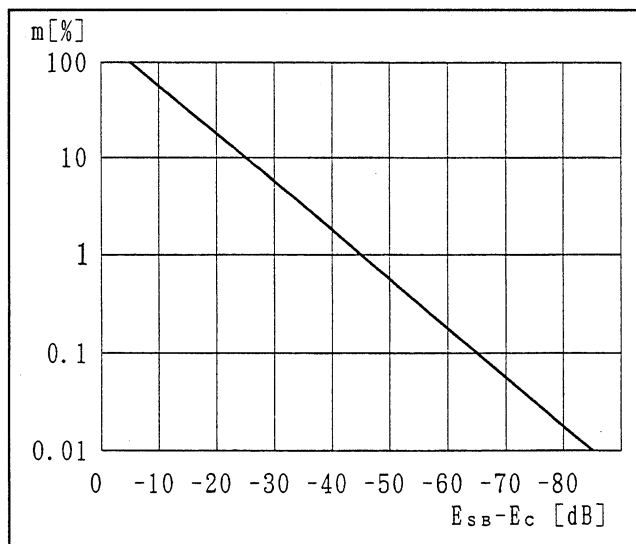

Figure 6-23 Sideband level

6.4.2 FM Signal Analysis

FM signals are most commonly analyzed to find the carrier frequency f_c , the frequency of the modulation signal f_m , frequency shift Δf_{peak} , the modulation index m , or the occupied bandwidth. The FM modulation index m is given by $\Delta f_{\text{peak}}/f_m$. It is known that for modulation indexes of 2.4, 5.6, 8.6, ... the FM carrier disappears.

So if the modulation frequency is known, by searching for carrier minimums we can determine either the modulation index m or the frequency shift Δf_{peak} . (See Figures 6-24(a) and (b).)

Just from looking at the complex spectrum of an FM signal it is not practical to try to determine what the modulation signal was.

It is if fairly easy to see the modulation to display by causing FM component of input signal to change the variation of amplitude.

Usually one would use an FM Discriminator circuit to do this sort of demodulation, but the spectrum analyzer can do Slope Detection of the modulation by using the slope of the IF BandPass Filter (B.P.F.).

The resulting detected signal can then be displayed (Figure 6-24(c)).

When the modulation frequency is low, by setting the horizontal axis frequency SPAN to zero, the spectrum analyzer can be used as a fixed tuned receiver to make measurements in the Time Domain.

Conversely, when the modulation frequency is high, the modulation frequency can be determined from the sideband frequencies.

Finally, for small modulation index (m less than 0.8 or so), m can be determined from the relation between the carrier level and the level of the first sideband frequency.

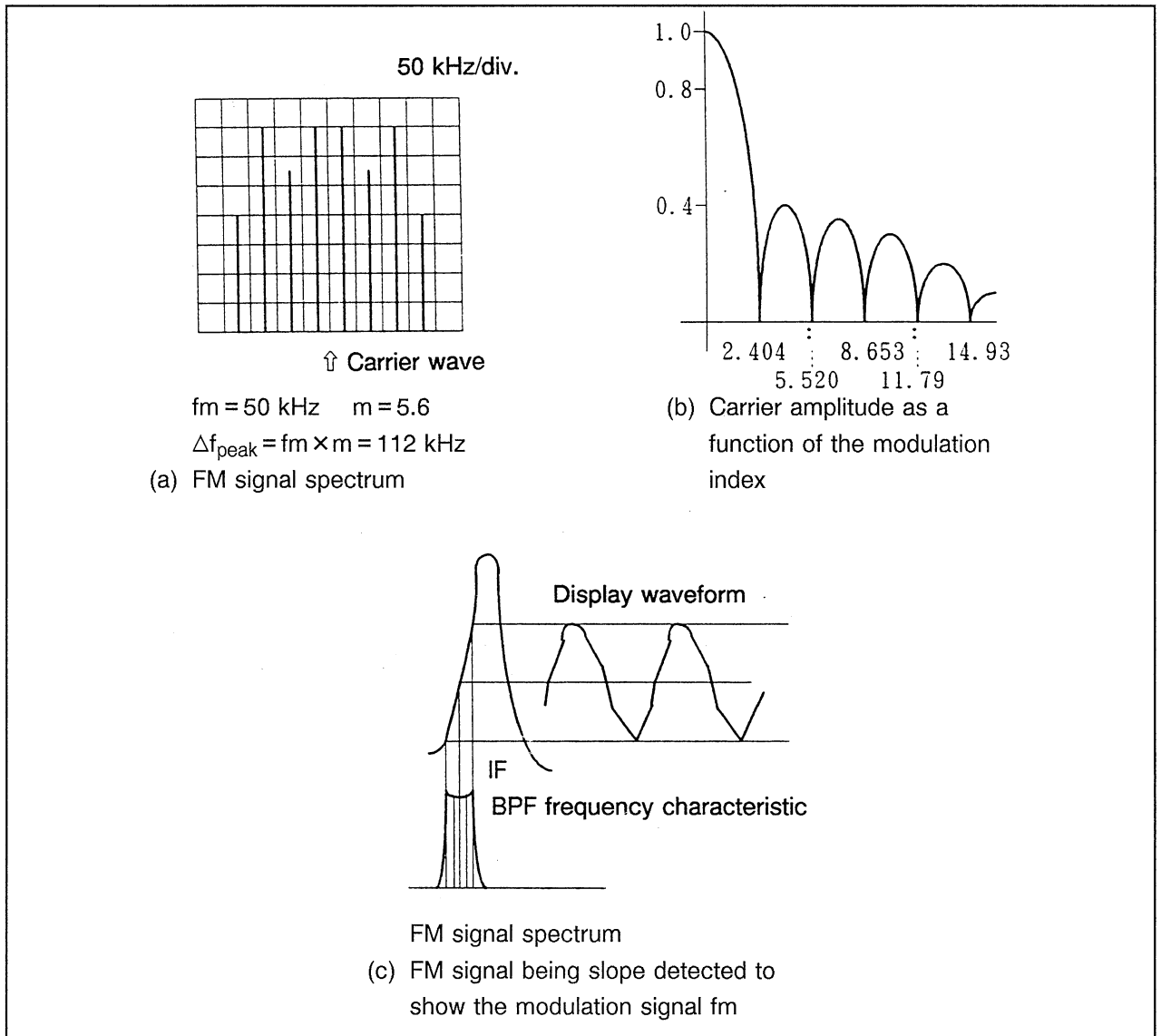
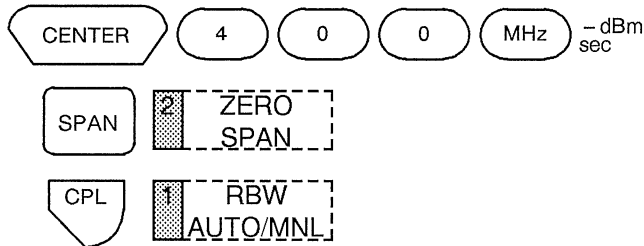



Figure 6-24 FM signal analysis

(1) Example analysis of an FM signal with low frequency modulation

- ① Set the center frequency to the carrier frequency, the frequency span to zero, and the resolution bandwidth to greater than three times the modulation frequency:



and use the   step keys set the desired RBW.

- ② Set the trigger mode to video trigger and the reference level to the peak level:

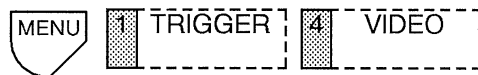



and then use the data knob  to adjust the trigger level.



- ③ Select a sweep time that allows viewing the demodulated signal easily:



and use the   step keys to set the sweep time.

- ④ Use the Δ marker to find the modulation frequency fm:



and then use the data knob  to move the Δ marker to the next peak.

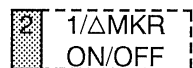

Choose ON, and then read the modulation frequency as the frequency of the $1/\Delta$ marker that appears at the top left of the screen.

(2) Analyzing an FM signal with high modulation frequency, low modulation index.

- ① Set the center frequency to the carrier frequency, the frequency span to greater than twice and less than ten times the modulation frequency:

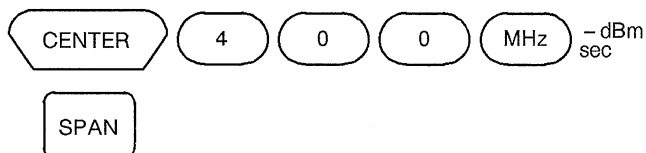

and use the step keys to set the desired span.

- ② The frequency difference between the carrier frequency and the sideband frequency is the modulation frequency f_m :



Move the marker to the carrier frequency.



and then use the data knob to move the Δ marker to the sideband peak.

The Δ marker frequency display at the top left of the screen is the modulation frequency.

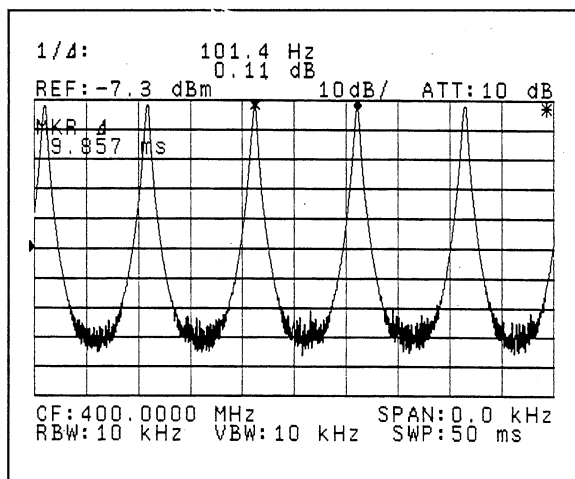

Figure 6-25 FM signal with low modulation frequency

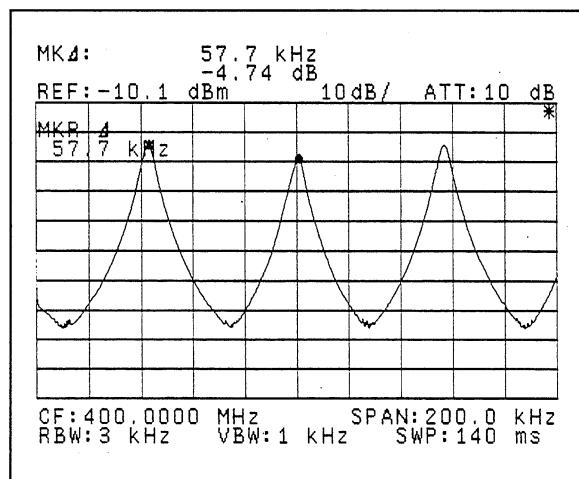
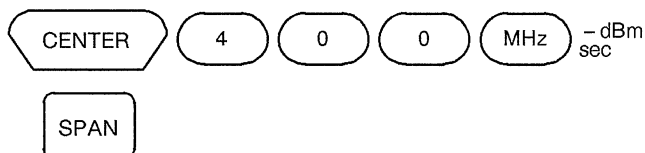

Figure 6-26 FM signal with high modulation frequency

(3) Measuring an FM signal peak shift (Δf_{peak})

- ① Set the center frequency to the carrier frequency, and the frequency span to slightly greater than the peak shift so that measurements can easily be made:



and use the step keys to set the desired span.

- ② Set the resolution bandwidth wide enough to include the main side bands (at least five times greater than the modulation frequency).



and use the step keys to adjust RBW.

- ③ Finally, move the Δ marker to the spectrum "shoulder" (see Figures 6-27 and 6-28). Call the Δ marker frequency Δf_{pp} . Then Δf_{peak} and modulation index m can be found from:

$$\Delta f_{\text{peak}} = \frac{1}{2} \Delta f_{\text{pp}}, \quad m = \frac{\Delta f_{\text{peak}}}{f_m}$$

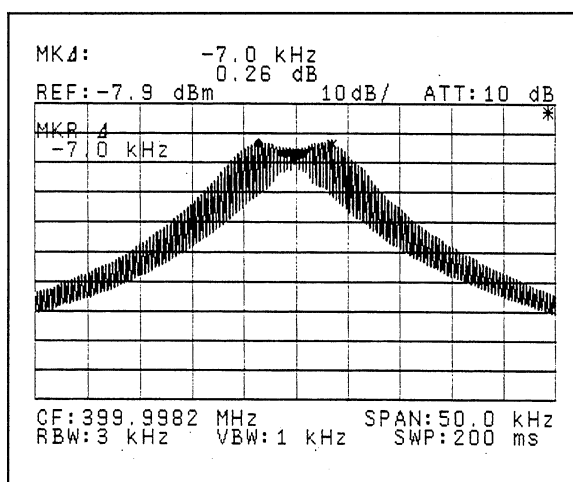

Figure 6-27 FM signal with small Δf_{peak}

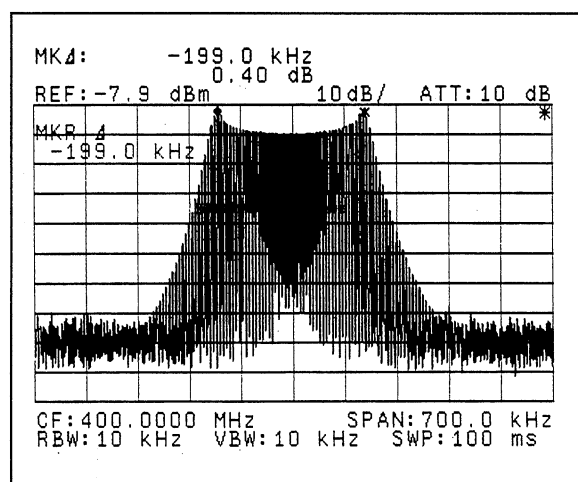

Figure 6-28 FM signal with large Δf_{peak}

(4) Finding the modulation index m when m is small

If the FM signal modulation index m is less than 0.8 or so, we can approximate it by on the linear scale:

$$m = \frac{E_{SB}}{E_C}$$

E_{SB} is the first sideband level
 E_C is the carrier level

- ① Set the center frequency to the carrier frequency, the frequency span so that the nearest sidebands can easily be seen, and the reference level to the carrier peak level:

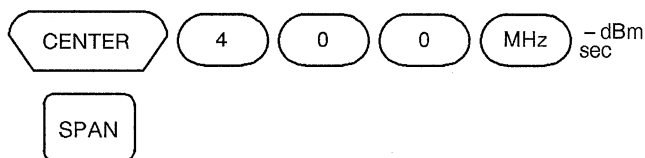

and use the step keys to adjust the span visible.



- ② From the operation of the key, we now have that the marker frequency is the carrier frequency f_C , and its level is the carrier level P_C [dB].

- ③ Make the Δ marker be positioned at the 1st sideband frequency location, then the Δ marker display gives the sideband frequency f_{SB} and its level P_{SB} [dB]:



and then use the data knob to adjust to the sideband peak.

- ④ Now using the results of steps and the following formulae will give the modulation index m , and the frequency shift Δf_{peak} :

$$m = 2 \times \frac{E_{SB}}{E_C} = \log^{-1} \frac{P_{SB} - P_C + 6}{20}$$

$$f_m = |f_{SB} - f_C|$$

$$\Delta f_{peak} = m \times f_m$$

SPECTRUM ANALYZER
OPERATION MANUAL

6.4 Modulation Signal Measurements

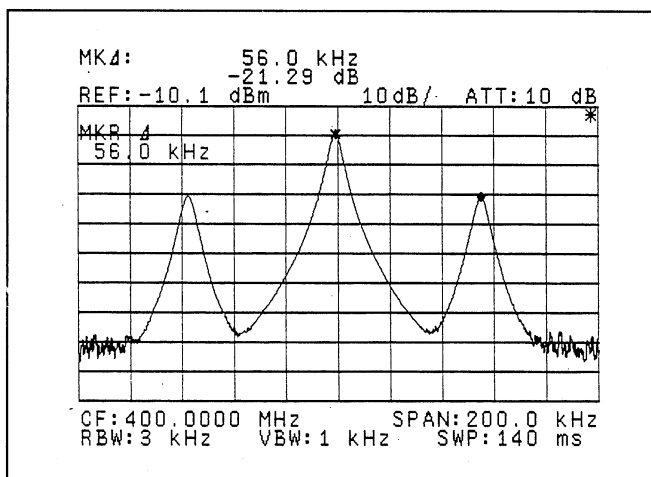

Figure 6-29 FM signal with small modulation index m

6.4.3 Measuring Pulse Modulated Signals

The spectrum analyzer can analyze pulse modulated waveforms, displaying the equivalent fundamental and higher harmonics that compose the pulse. A pulse modulated waveform such as seen on the time axis in Figure 6-30(a) when transformed to the frequency axis has a spectrum such as shown in Figure 6-30(b) with a carrier frequency f_c in the center of a spectral "envelope" surrounding it.

Pulse modulated waveforms (such as from RADAR) are commonly analyzed with spectrum analyzers to easily make the following sorts of measurements:

- Pulse repetition frequency (PRF)
- Pulse width (τ)
- Carrier frequency (f_c)
- Peak power (P_{peak})
- Average power (P_{ave})

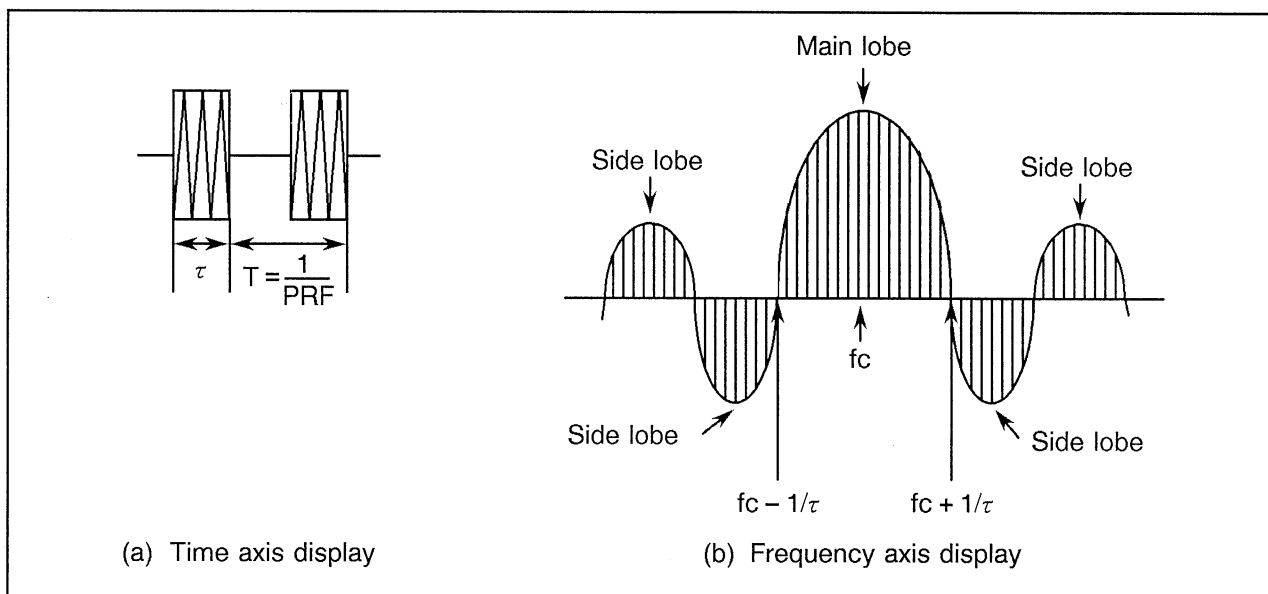

Figure 6-30 Pulse modulation

CAUTION

1. The maximum allowable input level to the analyzer is +27 dBm and or ± 50 VDC when the input attenuator is set to 10 dB or higher. Since pulse modulated signals (like radar) can often have very high peak powers, a directional coupler or other attenuator should be inserted in front of the analyzer to provide sufficient attenuation.
2. The total input attenuation should be set so that the P_{peak} will be less than the -10 dBm maximum level at the mixer input. To avoid mixer saturation it is recommended that you begin with a maximum 50 dB of input attenuation, then reduce the attenuation 10 dB at a time as long as the signal level does not decline (no gain compression). This will find the smallest attenuation necessary.

(1) Pulse width (τ)

Pulse width (τ) is either the inverse of 1/2 the main lobe width, or the inverse of the side lobe width. In order to get a sufficiently well resolved lobe envelope the Resolution Bandwidth should be satisfy the following inequalities:

$$\text{Pulse repetition frequency (PRF)} \times 1.7 \leq \text{Resolution bandwidth} \leq 0.1/\tau$$

(2) Carrier frequency (f_c)

The measurement accuracy of the carrier frequency (f_c) is determined by the pulse width τ . When τ is small the main lobe spreads and it is more difficult to establish its center. In order to display the center clearly, it is necessary to set the SPAN/DIV wider than τ .

This gives a measurement accuracy of the carrier frequency (f_c) which is equal to the center frequency accuracy for that SPAN/DIV.

(3) Peak power (P_{peak})

As long as the spectrum analyzer resolution bandwidth satisfies the following inequality:

$$\text{Pulse repetition frequency (PRF)} \times 1.7 \leq \text{Resolution bandwidth} \leq 0.2/\tau$$

Then the true peak power (P_{peak} in dBm) can be found from the apparent peak level displayed P'_{peak} (dBm) by the analyzer:

$$P_{\text{peak}} = P'_{\text{peak}} - \alpha \text{ (dB)}$$

where α , the pulse attenuation factor is:

$$\alpha = 20 \log (\tau \times 1.5 \times \text{RBW})$$

(4) Average power (P_{ave})

The average power (P_{ave} in dBm) can be found from:

$$P_{\text{ave}} = P_{\text{peak}} \times \text{PRF} \times \tau$$

Where as before PRF is the pulse repetition frequency in Hz and τ is the pulse width in seconds.

6.5 Occupied Bandwidth (OBW) Measurement

The analyzer has an OBW function that can calculate the occupied bandwidth from the measurement data displayed on the screen. It works by finding the frequency band that contains a specified percentage of the total power. Initial the default value is 99%, but any value between 10.0% and 99.8% can be specified.

CAUTION

If the signal level is displayed as being below 50 dB then increased calculation errors can arise. Change the Reference Level so as to make the signal amplitude be greater than 50 dB. The Span should be set at about three times the expected occupied bandwidth.

(1) Measurement procedure

- ① Set the center frequency to the known carrier frequency (or use the PEAK function if it is unknown), and set the span, resolution bandwidths, and sweep time to their expected (or estimated) values:

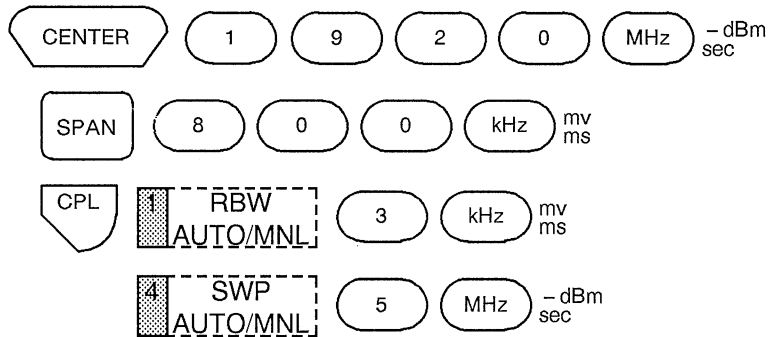

- ② Set the trace detector to posi peak mode:



- ③ Calculate the occupied bandwidth:

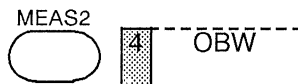

**SPECTRUM ANALYZER
OPERATION MANUAL**

6.5 Occupied Bandwidth (OBW) Measurement

When the calculation is complete, the occupied bandwidth and the carrier frequency (Fc is actually the occupied band center frequency) appear at the top left of the screen. Markers are set at both sides of the occupied band to indicate the band endpoint frequencies. For example, in a 99.0% OBW case, there is 0.5% of the total power in the tail to the left of the left marker, and 99.5% of the total power to the left of the right marker.

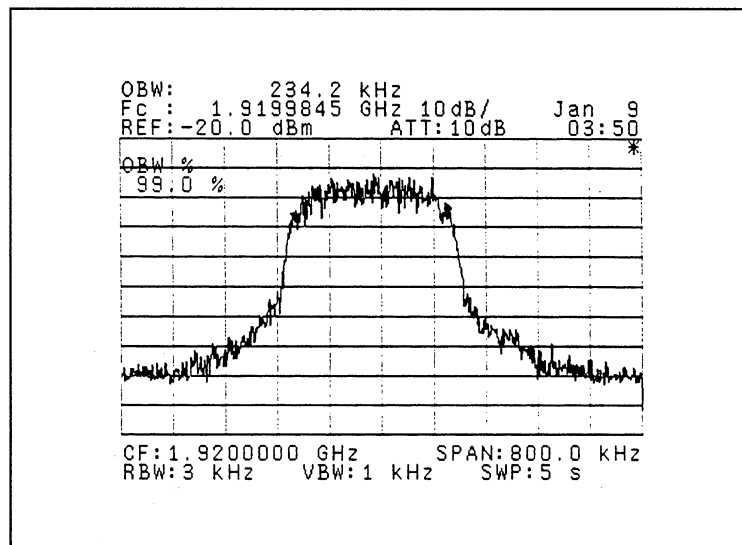

Figure 6-31 OBW measurement

- ④ To change the ratio between the power contained in the occupied band and the total power first find the OBW as before, then use the numeric pad to set a new percentage, and the band markers will be adjusted to suit. For example, to change to an 80% bandwidth:

Press MEAS2 4 OBW 8 0 Hz μ S and the display will be

changed to an 80% OBW.

6.6 Adjacent Channel Leakage Power (ACP) Measurement

The analyzer ACP function works by first calculating the total power under the spectrum displayed on the screen. Then the percentage of the total power that is found in each channel is calculated. Note that the user must specify the channel bandwidth (see below BS = Specified Bandwidth.)

The analyzer has two ways of making adjacent channel leakage power measurements:

ACP POINT : For a specified channel spacing, the leakage power in the adjoining upper and lower channels is found.

ACP GRAPH: Given only the channel width, the entire frequency span is divided into channels, and the power in each channel is calculated and stored in B Trace Memory. The B Trace is then also displayed.

CAUTION

1. The analyzer's dynamic range will be degraded if the signal level is much lower than the reference level. Use a span of 4 or 5 times the (radio) channel spacing.
2. ACP measurement can be carried out only trace A. It cannot be carried out by trace B.

(1) Measurement procedure

- ① Set the center frequency to the carrier frequency, and the frequency span and resolution bandwidth to their expected values:

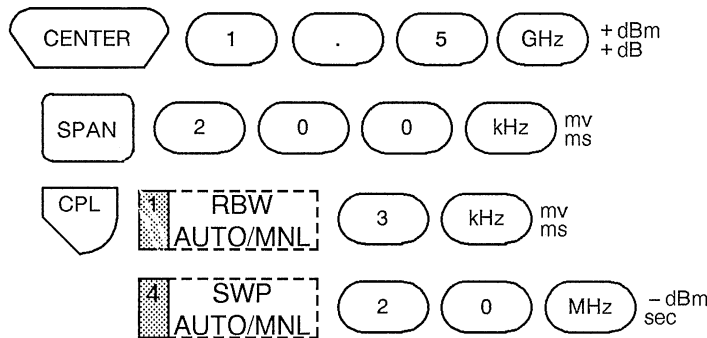

Press **REF LEVEL** and use the data knob \odot to adjust the reference to be near the signal peak level.

**SPECTRUM ANALYZER
OPERATION MANUAL**

6.6 Adjacent Channel Leakage Power (ACP) Measurement

- ② Set the trace detector to Posi peak mode:



- ③ From here on the procedure depends on the type of measure desired,

- (a) ACP POINT
- (b) ACP GRAPH

- (a) ACP POINT measurement

- (a-1) Set the marker to the specified channel frequency:



- (a-2) Go into the adjacent channel leakage power mode, and specify the channel width and spacing:

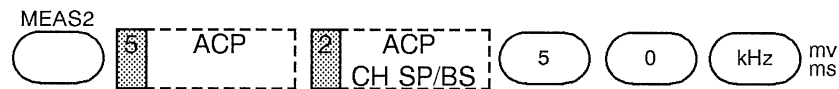

Choose CH SP and then enter the channel spacing.

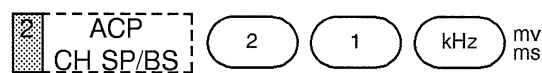

Choose BS and then enter the channel bandwidth.

- (a-3) Execute the ACP POINT measurement:



Markers appear at the neighboring upper and lower channel frequencies, and the display at the upper left shows the fractional power (as dB from the center channel) in each.

**SPECTRUM ANALYZER
OPERATION MANUAL**

6.6 Adjacent Channel Leakage Power (ACP) Measurement

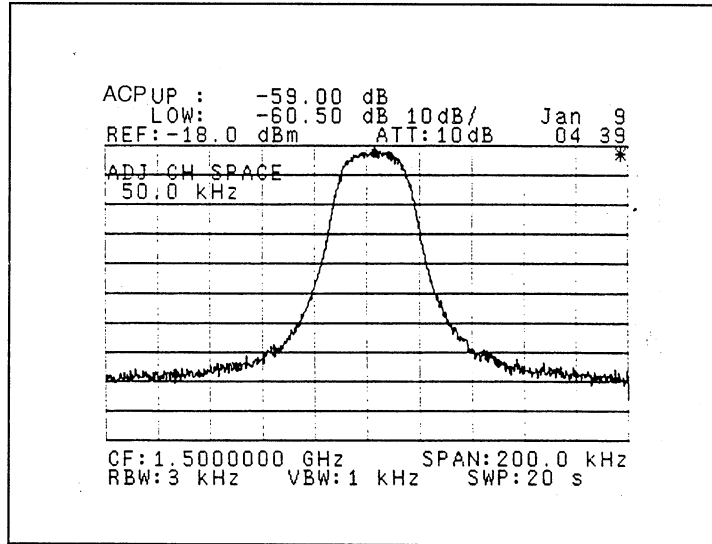

Figure 6-32 ACP POINT mode measurement of adjacent channel leakage power

CAUTION

1. Always be sure that the markers appear at the adjacent channel locations. If the channel width and spacing is not specified (see step (a-2), or if the values are incompatible or inconsistent, then the ACP POINT function will not work.
2. After using the marker to make any measurement, the marker automatically changes into a Δ marker. Be sure to adjust the marker to the specified channel frequency before making the measurement.

(b) ACP GRAPH measurement

(b-1) Go into the adjacent channel leakage power mode, and specify the channel width:

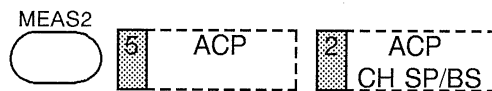

Choose BS and then enter the channel bandwidth

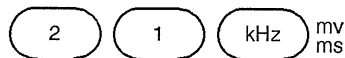

SPECTRUM ANALYZER
OPERATION MANUAL

6.6 Adjacent Channel Leakage Power (ACP) Measurement

(b-2) Execute the ACP GRAPH measurement:

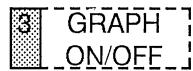

Choose OFF and then enter the graph.

The adjacent channel leakage power measurement appears on the screen as the B Trace. Each time GRAPH is pushed it is remeasured.

(b-3) Press , and move the marker to the channel spacing position.

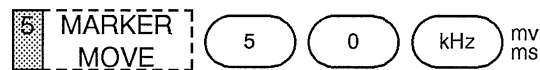

The display area at the top left of the screen will show the relative channel spacing and the adjacent channel leakage power.

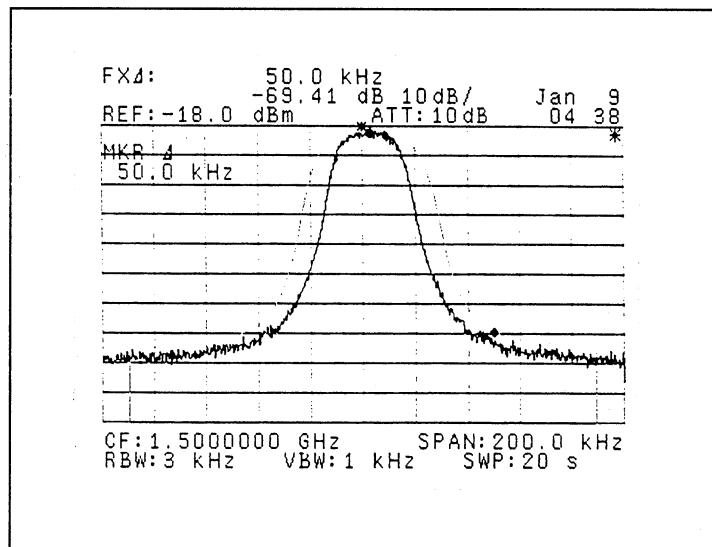

Figure 6-33 ACP GRAPH mode measurement of adjacent channel leakage power

CAUTION

This function will not operate if the channel bandwidth is not set, or is not set correctly.

6.7 Television Carrier Signal Measurements

CAUTION

The input impedance of U3641/3641PHS is 50 Ω . Use a 75 Ω to 50 Ω adapter or other impedance converter as necessary to match the U3641/3641PHS impedance to the rest of the system under test, and measure the television broadcast signals with dB μ V unit type.

As may be seen in Figure 6-34, one broadcast television channel is composed of a video signal carrier (f_V), audio signal carrier (f_A), and color signal (sub)carrier (f_S). f_V is Amplitude Modulated, and f_A is Frequency Modulated; after Amplitude Modulation, f_S is processed into vestigial-sideband signal. All three components are combined to make the broadcast signal. The bandwidth of one channel is 6 MHz. With respect to the video carrier f_V , f_A is spaced 4.5 MHz above, and f_S is 3.58 MHz above.

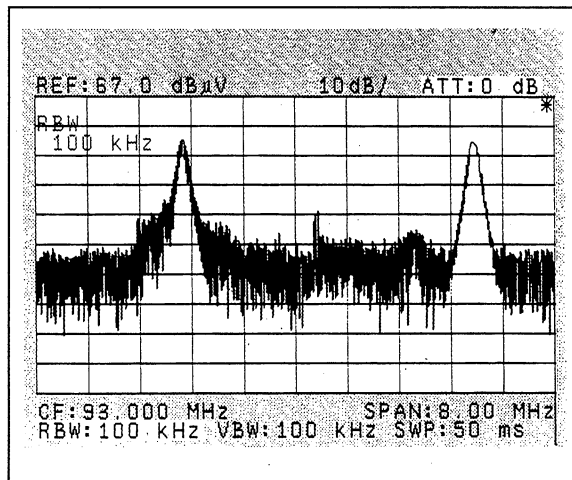

Figure 6-34 NTSC signal (1 channel)

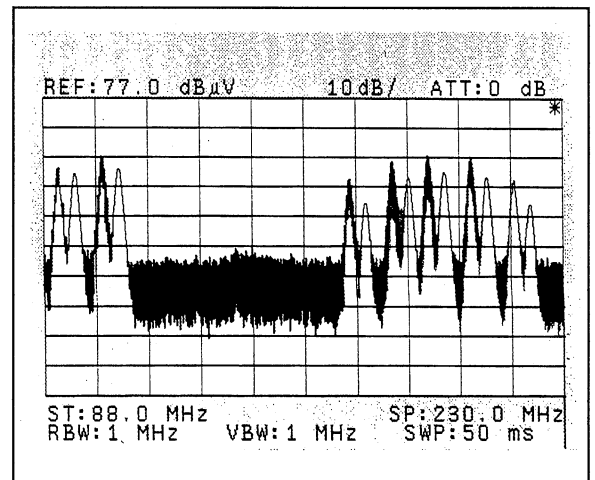

Figure 6-35 NTSC signal (12 channel)

Television broadcast channels are divided into two bands, VHF and UHF. In Japan, the VHF band contains channels 1 through 12 (90 to 108 MHz, 170 to 222 MHz) as shown in Figure 6-36 (However, channels 7 and 8 have a 2 MHz overlap).

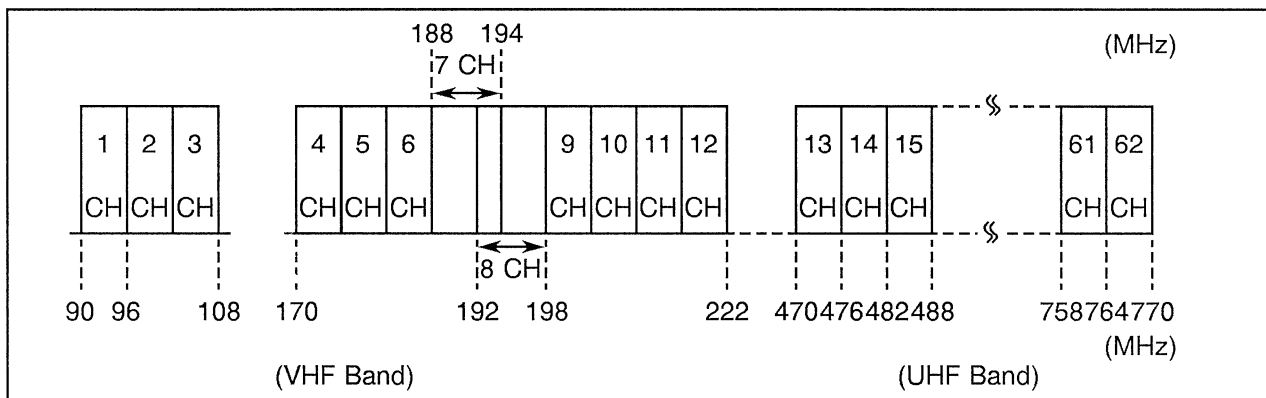

Figure 6-36 VHF and UHF channel assignments

UHF channel assignments are for channels 13 through 62 (470 to 770 MHz). In total there are 62 standard broadcast channels in Japan.

Thus we see that there are many channels of television broadcast signals. The spectrum analyzer can be the most efficient tool in measuring each channel's level and frequency, and in presenting at a glance the overall situation of the entire broadcast band.

The following television broadcast signals measurements are explained here by using the U3641N at the input impedance of 75 Ω .

1. V/A Measurement.
2. Satellite Broadcast Signal C/N Measurement.

6.7.1 V/A Measurement

The V/A is the ratio of the Video and Audio levels.

If the audio level is too much below the video level a "buzz" noise interferes with the sound. Conversely, too high an audio level will lead to cross-modulation noise of the video signal. Therefore it is necessary to properly adjust the relative carrier levels, and the spectrum analyzer makes it easy to do.

In the following we will consider the adjustment of a VHF signal, NHK Channel 1 in Japan.

- ① Set the center frequency to 91.25 MHz, frequency span to 8 MHz.

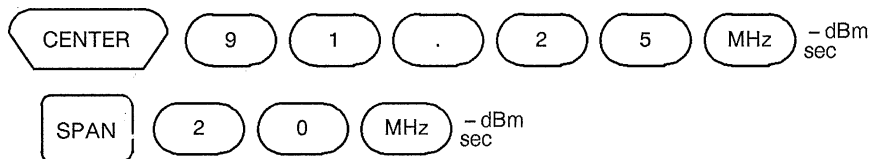

- ② Consider a level change to execute the max. hold function for approx. 1 minute.



Wait for approx. one minute.

- ③ Measure the picture transfer wave level and sound transfer level.

Press the ^{OFF} MKR key to move a marker point to the peak position for the picture transfer wave using the data knob \odot . The marker level shows the picture transfer wave level V (dB μ V).



and move a marker point to the peak position for the sound transfer wave using the data knob \odot . The marker level shows the sound transfer wave level A (dB μ V).

- ④ The V/A is found from the following formula:

$$\text{VA comparison} = \text{Picture transfer wave level (dB}\mu\text{V)} - \text{Sound transfer wave level A (dB}\mu\text{V)}$$

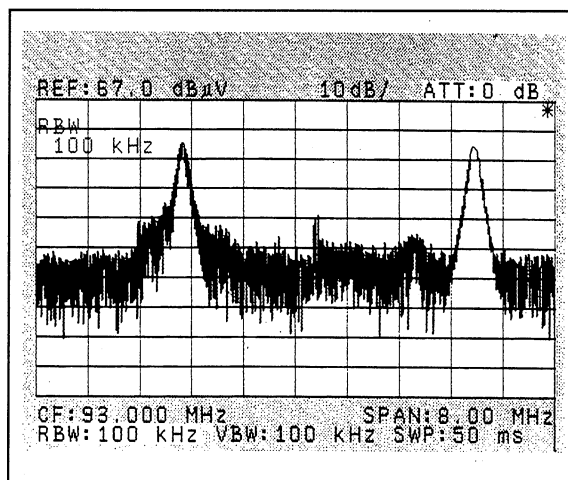

Figure 6-37 V/A measurement

6.7.2 Satellite Broadcast Signal C/N Measurement

In order to assure quality reception of a satellite broadcast signal, the carrier to noise ratio, C/N must be good. The analyzer is possible to make highly accurate measurements of C/N even during program broadcast transmission. The relationship between picture quality and C/N is shown in Figure 6-38.

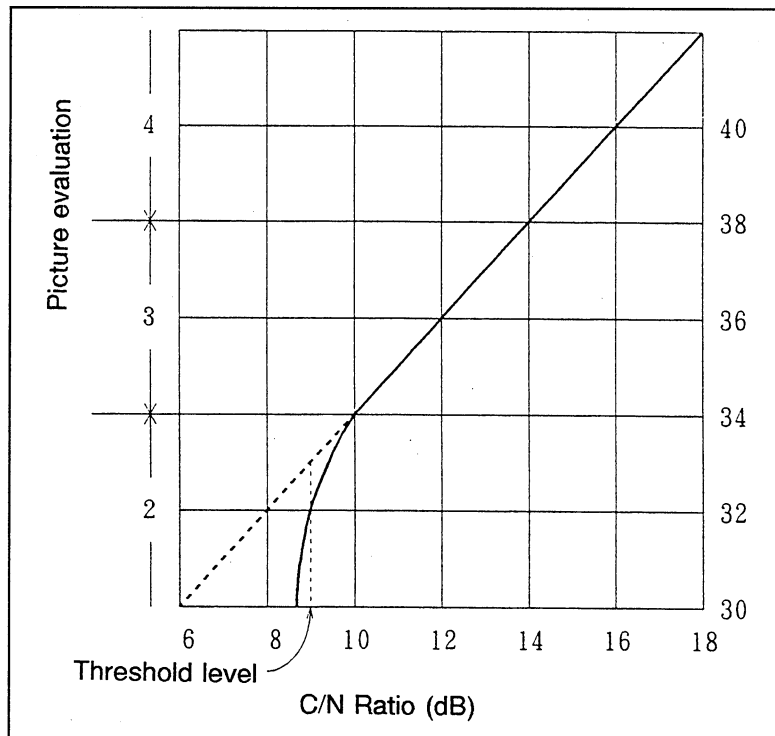

Figure 6-38 Picture quality vs C/N

Where C (dB μ V) is the signal carrier level, and N (dB μ V $\sqrt{\text{Hz}}$) is the noise level per Hertz. The 74.31 (dB) is a conversion of an ideal 1 Hz noise into the 27 MHz broadcast channel bandwidth.

$$\text{C/N Ratio (dB)} = C - N - 74.31 \text{ (dB)}$$

Using the Noise/Hz measurement mode, measure the noise level with the value calculated to 27 MHz, at a frequency about 17 MHz away from the carrier and so outside the BS-5 channel:

The procedure for measuring C/N on a Japanese BS-5 channel is as follows:

**SPECTRUM ANALYZER
OPERATION MANUAL**

6.7 Television Carrier Signal Measurements

- ① Measure the carrier signal level.

Set the center frequency the 1,126 MHz IF corresponding to BS-5, the frequency span to 50 MHz, RBW to 300 kHz, and VBW to 10 kHz:

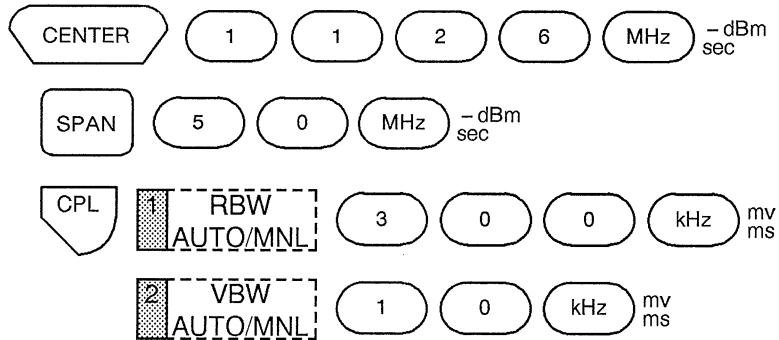

Press **REF LEVEL** and use the step keys and the data knob to adjust the reference to a convenient location.

If the input signal level is weak and the S/N ratio is poor, select the internal pre-amplifier ON.

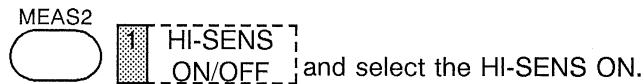

- ② Unlike the AM signal of terrestrial broadcast signals, the IF signals from satellite broadcast signals are FM. Thus, depending on the video image the spectrum can change from moment to moment. Get around this by using the Maximum Hold function to accumulate the spectrum:

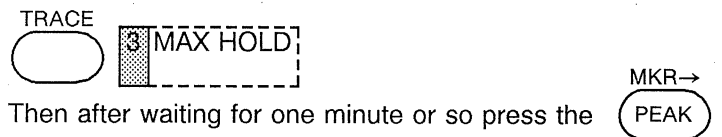

Then after waiting for one minute or so press the **PEAK** button. Display the marker level displayed at the top left of the screen as the carrier level C (dB μ V).

According to the above procedure, measurement of the transfer signal level is completed.

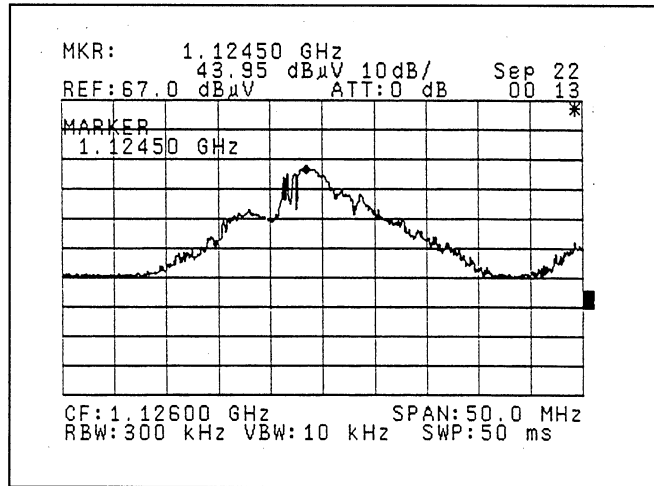
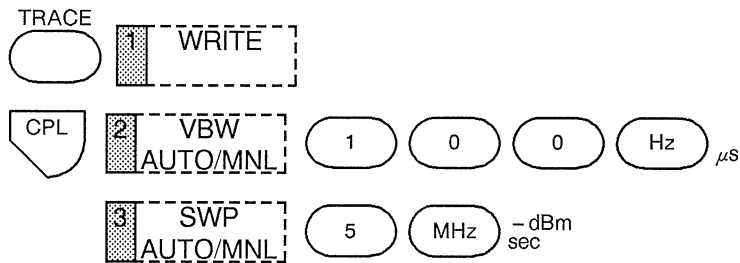

Figure 6-39 Carrier signal level measurement

③ Noise level measurement

Release the MAX-HOLD of step (1), and set the VBW to 100 Hz, sweep time to 5 seconds:



Since the broadcast signal is being constantly modulated it is impossible to measure just the noise inside the channel.

Accordingly, measure the noise level at an unused frequency as close as possible to the channel of interest.

**SPECTRUM ANALYZER
OPERATION MANUAL**

6.7 Television Carrier Signal Measurements

- ④ Using the Noise/Hz function, measure the noise level with the value calculated to 27 MHz, at a frequency about 17 MHz away from the carrier and so outside the BS-5 channel:

The procedure for measuring C/N on a Japanese BS-5 channel is as follows:

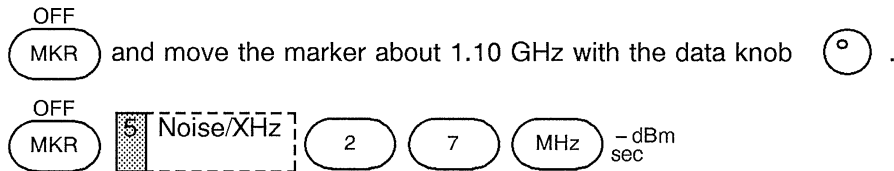

Set the bandwidth to the satellite broadcast channel bandwidth 27 MHz.

Accordingly, press the $2 \text{ dB}\mu\text{V}/\sqrt{\text{Hz}}$ key and display the Marker Level as the noise level $N \text{ (dB}\mu\text{V}/\sqrt{\text{Hz}})$ calculated to bandwidth 27 MHz.

- ⑤ Compute the C/N from the formula:

$$\text{C/N (dB)} = \text{Carrier Level} - \text{Noise level} - 74.3(\text{dB})$$

(In case of Figures 6-39 and 6-40)

$$\text{C/N Ratio (dB)} = 43.95 - 24.68 = 19.27 \text{ dB}$$

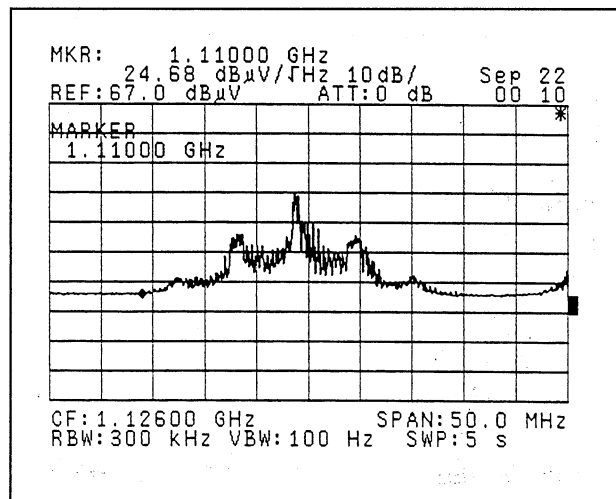

Figure 6-40 Noise level measurement

6.8 Analyzing Burst Signal Spectra

You can analyze burst signal spectra using the analyzer's gated sweep function. Burst signal measurements are often necessary when working with magnetic tape equipment such as VTR, 8mm video, and digital audio tape (DAT) equipment.

The measurement method is shown below.

To analyze a burst signal spectrum, use the GATE IN terminal on the analyzer's rear panel for gate control. The sweep starts at the TTL level "High" (or Open) and stops at "Low".

Set the input signal and the gate control signal as specified below.

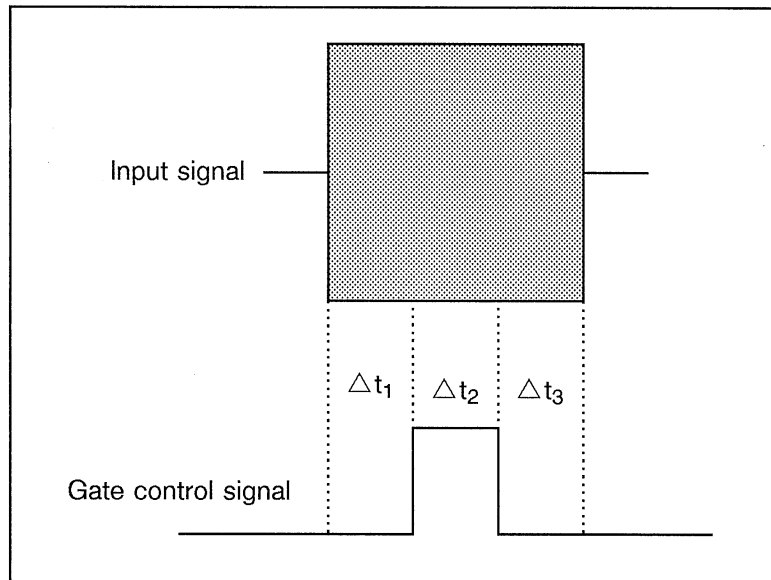

	RBW				
	3 MHz, 1 MHz	300 kHz	100 kHz	30 kHz	10 kHz
Δt_1	2 μ s or more	15 μ s or more	20 μ s or more	50 μ s or more	180 μ s or more
Δt_2	1 μ s or more				
Δt_3	1 μ s or more				

Note: When measuring noise, set the detection mode to SAMPLE.

7. FUNCTION DESCRIPTIONS

7.1 Functions of the Fundamental Keys

The following seven keys are called "Fundamental keys".

1. CENTER : Center frequency
2. SPAN : Frequency span
3. START : Start frequency
4. STOP : Stop frequency
5. REF LEVEL : Reference level
6. CPL : Coupled (for setting RBW, VBW, SWP and ATT)
7. MENU : Select menus (for setting trigger, sweep, detector, AM/FM modulation, display color)

Fundamental keys are shown in Figure 7-1.

The legend of the display is shown in Figure 7-2.

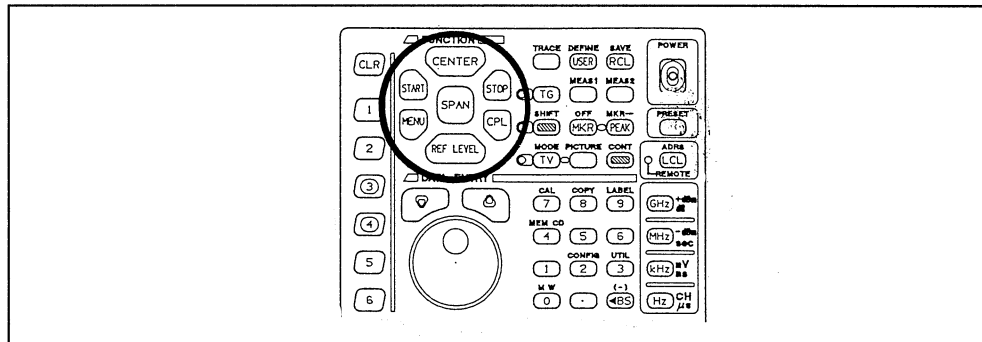

Figure 7-1 Front panel fundamental keys

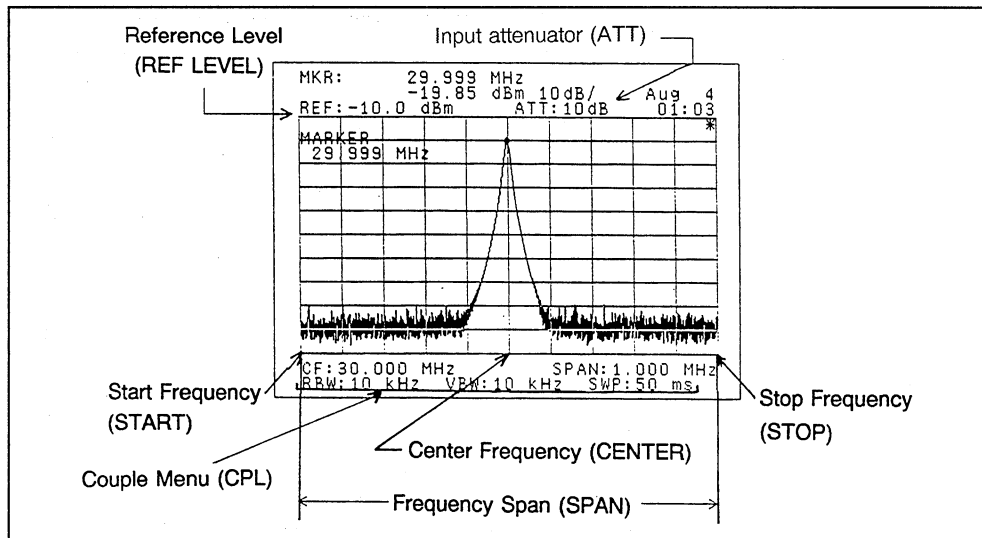
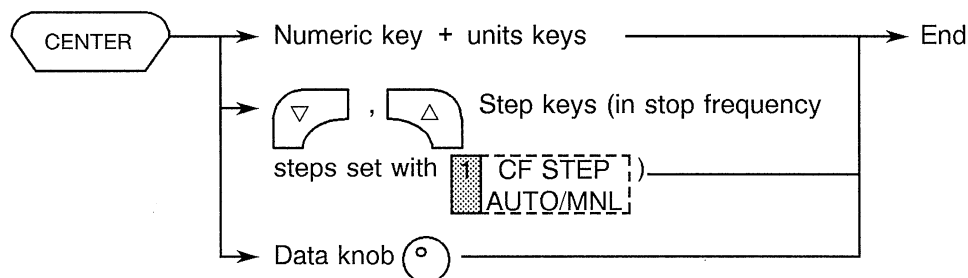

Figure 7-2 Display legends

7.1.1 Center Frequency

- (1) Center frequency setup procedure (Frequency range: 0 to 3.0 GHz)



- (2) Menu explanation

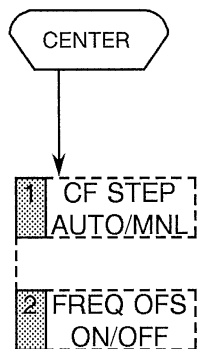

Displays center frequency softmenu.

When softmenu disappears (display *), center frequency is displayed in the active area and can be set by procedure (1).

Select MNL to set the center frequency step size. In AUTO, the step size is set to 1/10 of the frequency span.

When ON is selected, a frequency offset (0 to ±10 GHz) can be set to modify the center frequency. However, if an offset less than the RBW is entered, it will be replaced with the RBW.

$$\text{Center frequency (Displayed)} = \text{Center freq. (SET)} + \text{Offset freq.}$$

When OFF is selected, the offset is removed.

7.1.2 Frequency Span

- (1) Frequency span setup procedure (Frequency range: 0 Hz, 1 kHz to 3.2 GHz)

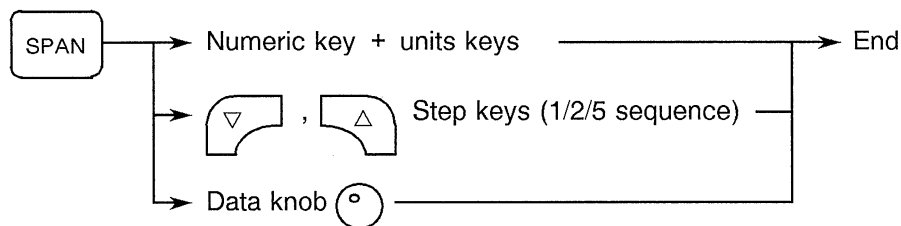

(2) Frequency span menu explanation

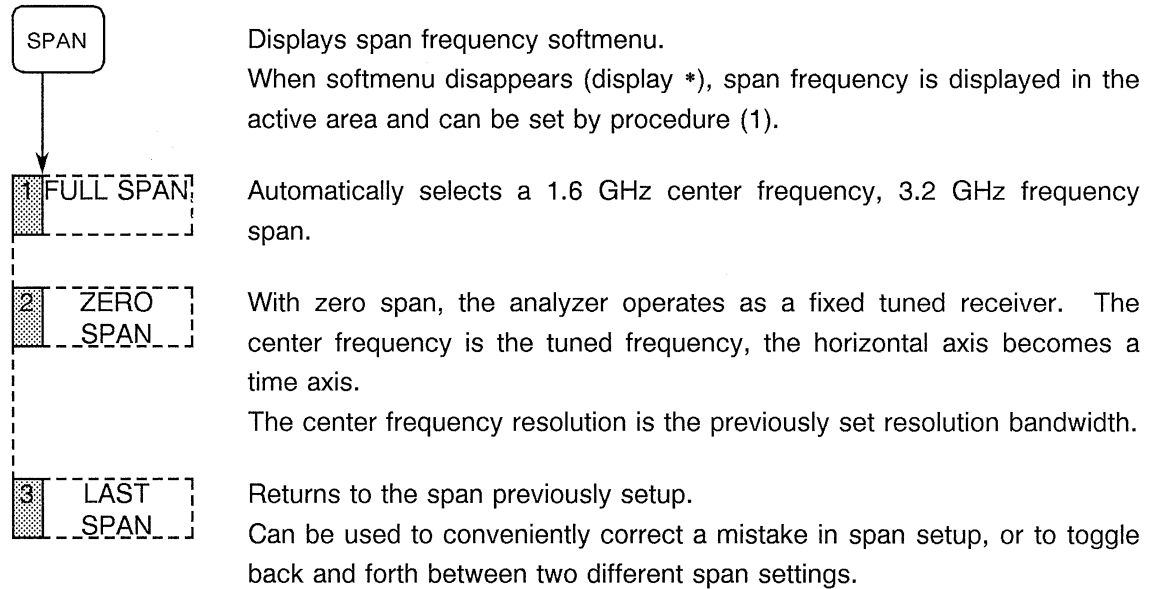

7.1.3 START, STOP Frequencies

- (1) START, STOP frequency setup procedure
 (Start frequency range: -200 MHz to 3.0 GHz)
 (Stop frequency range: 0 Hz to 3.2 GHz)

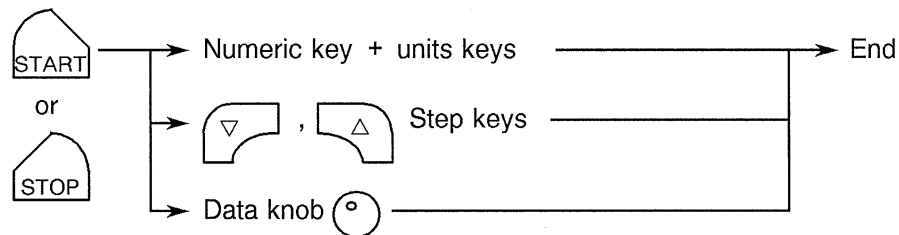

(2) Menu explanation

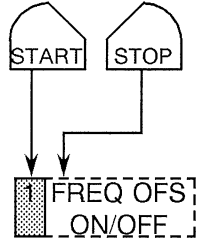

Displays Start/Stop frequency softmenu.

When softmenu disappears (display *) Start/Stop frequency can be set by procedure (1).

When ON is selected, an offset of 0 to ± 10 GHz can be specified. However, if an offset less than the RBW is entered, it will be replaced with the RBW.

$$\begin{aligned} \text{START frequency (Displayed)} &= \text{START freq. (SET)} + \text{Offset freq.} \\ \text{STOP frequency (Displayed)} &= \text{STOP freq. (SET)} + \text{Offset freq.} \end{aligned}$$

When OFF is selected the offset is removed.

7.1.4 Reference Level

(1) Reference level setup

The reference level setting range is shown in Table 7-1, and the relation between the reference level and the input attenuator are shown in Table 7-2.

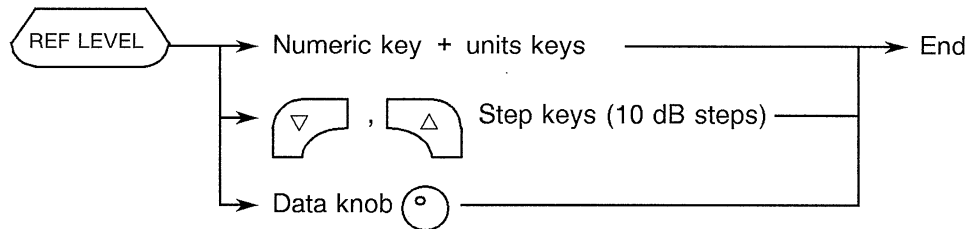

CAUTION

When the input attenuator is set to MANUAL, the reference level is depending on the attenuation value set, and the setting range may be narrower than the range shown in Table 7-1.

Table 7-1 Reference level setting range

Reference level range	U3641/3641PHS	U3641N
Preamplifier OFF	- 64 to + 40 dBm	+ 46 to + 150 dB μ V
Preamplifier ON	- 84 to + 15 dBm	+ 21 to + 125 dB μ V

Note: Reference level can be set according to Table 7-1 shown above.

(2) Menu explanation

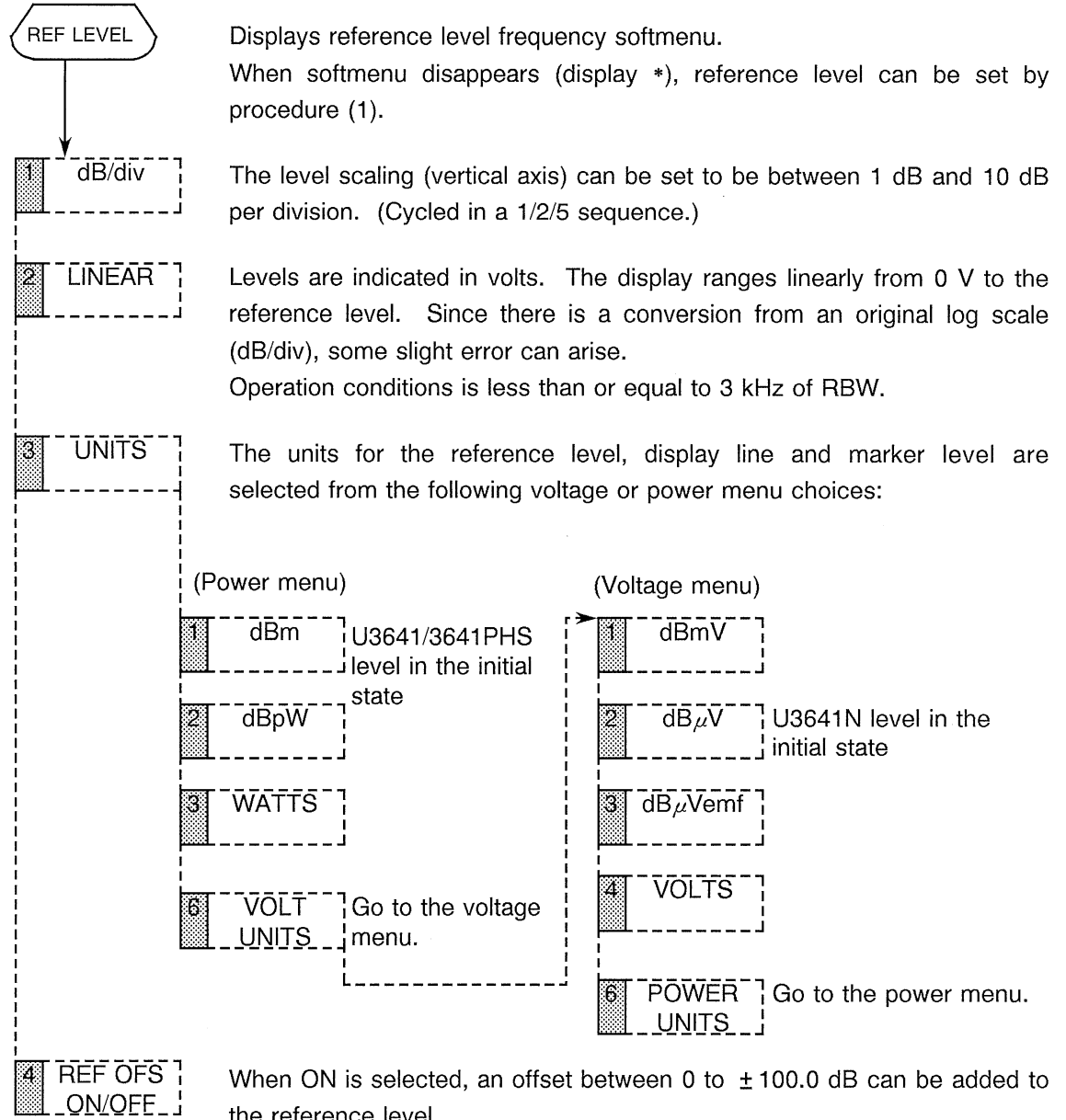

$$\text{Reference level (Displayed)} = \text{Reference level (SET)} + \text{Offset level}$$

When OFF is selected the offset is removed from the display.

7.1.5 Couple Key (CPL)

The CPL key is used to set the following interrelated items:

- RBW : Resolution bandwidth
- VBW : Video bandwidth
- SWP : Sweep time
- ATT : Attenuator (Input attenuator)

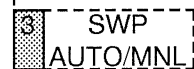
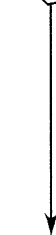

See section "6.1 Spectrum Analyzer Parameters Common to All Measurements" for more information about their meanings, etc.



Displays couple function softmenu.

When softmenu disappears (display *), by pressing this key enables the active function in order of RBW → VBW → SWP → ATT → RBW → Each function can be used in the following procedure:

If the data is changed, the manual setting only can be used. However,

using the  and , each function can be set to AUTO mode.

Sets the resolution bandwidth (RBW).

In manual mode, MNL, the RBW can be specified to be between 1 kHz and 3 MHz (100 Hz and 300 Hz at option) in a 1/3 sequence. In AUTO mode, an optimal RBW is set depending on the frequency span.

Sets the video bandwidth (VBW).

When MNL is set, VBW can be set in the range of 10 Hz to 3 MHz in 1-3 steps.

Sets the sweep time (SWP).

In MNL mode, the sweep time can be set between 50 msec and 1000 sec. When the frequency span is set to 0Hz, the SWP can be set between 50μsec and 1000sec, inclusive.

In the range between 50msec and 10sec, the SWP can be input with 1msec resolution. After the SWP input, an approximate value is calculated and set. (The setting resolution is approximately 2msec to 3msec.)

In AUTO mode, an appropriate SWP is chosen depending on the frequency span, RBW, VBW and so forth, in such a way as to avoid any measurement error.

CAUTION

When the sweep time is faster than 50msec, the SAMPLE detector mode is automatically established.

4 ATT AUTO/MNL	Sets the attenuator (ATT). In MNL mode, the input attenuation can be set in 10 dB steps to be between 0 and 50 dB. However, the input attenuation 0 dB can be set by using the numeric key only. In AUTO mode, an optimum attenuation is chosen depending on the reference level to be between 10 and 50 dB.
5 WIDE RBW ON/OFF	This menu is displayed when set to the zero span. ON: Turns on the WIDE RBW(5 MHz), and turns off the VBW(displayed as ***). (Note) A frequency of 0 Hz must be set when saving this data in CSV format or outputting the VBW value using the GPIB. OFF: Turns off the WIDE RBW.
6 ALL AUTO	All of the coupled measurement parameters are set automatically depending on the current frequency span and reference level.

7.1.6 Menu Key

The MENU key is used to set up the following:

1. TRIGGER : Trigger mode
2. TRACE DET : Trace detector mode
3. SWEEP MODE : Sweep mode
4. SOUND : Sound monitor mode
5. DSP LINE : Display line setting
6. COLOR : Display color setting

(1) Trigger mode setup

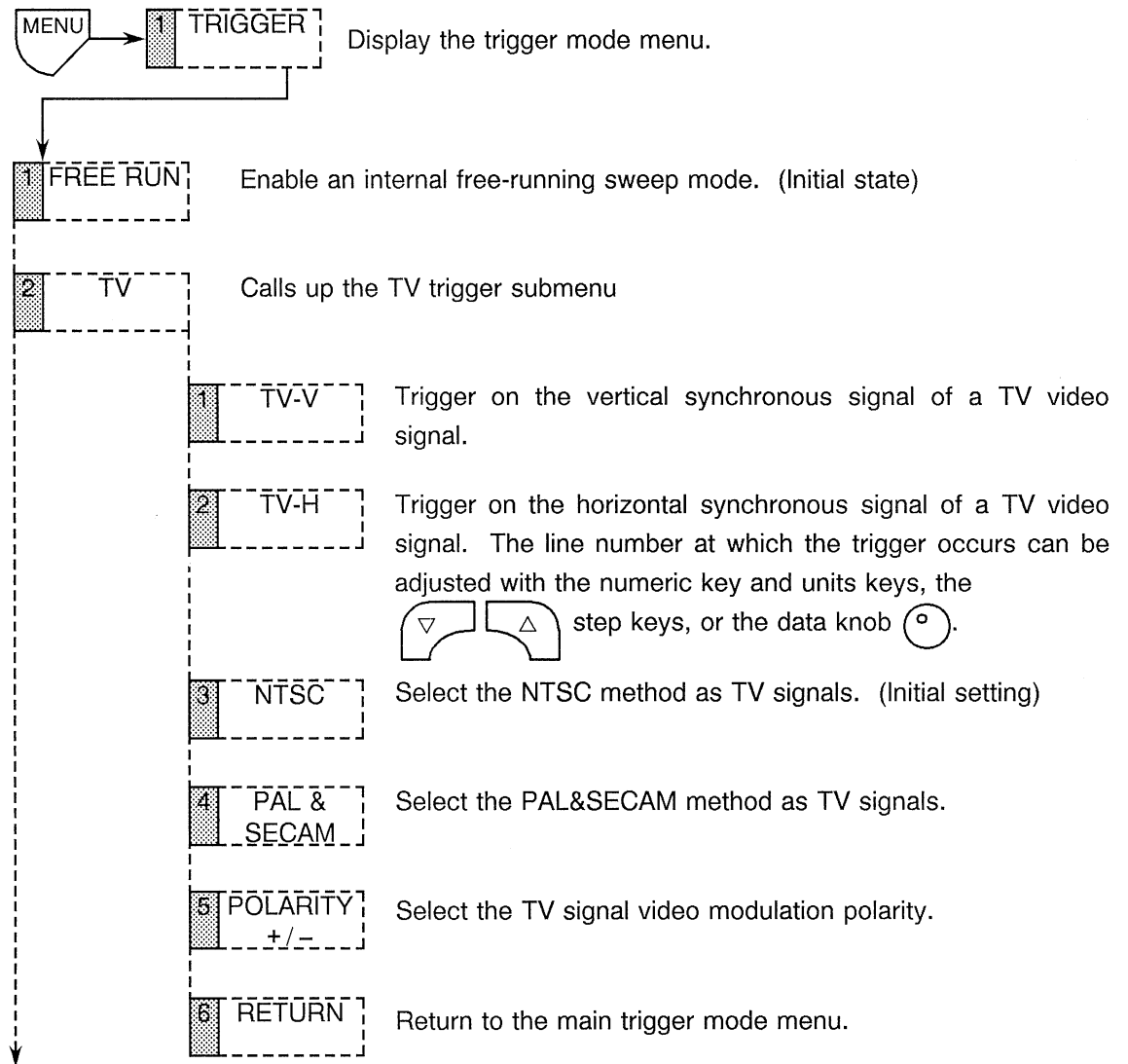

SPECTRUM ANALYZER
OPERATION MANUAL

7.1 Functions of the Fundamental Keys

3 TRIGGER
POSITION

Note: This menu is displayed when the sweep time is set at 19 msec or less.

The trigger position can be changed in the range of 0 to 100% (in 10% steps).

Therefore, the waveform before the trigger can be observed.

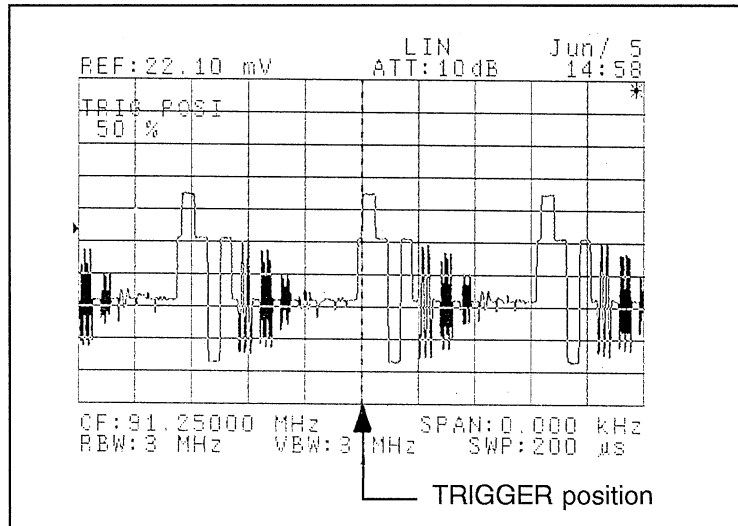
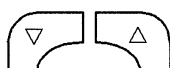



Figure 7-3 TRIGGER position

4 VIDEO

Set the trigger level point at the level indicated by the on-screen marker.

When this mode is selected, a → symbol appears on the left side of the display to mark the current video trigger level. The level can be set with the numeric key and units keys, the



step keys, or the data knob .

Taking the full scale vertical axis to be 100, the trigger level is shown as a percentage in the display active area. Figure 7-4 shows a waveform with a video trigger.

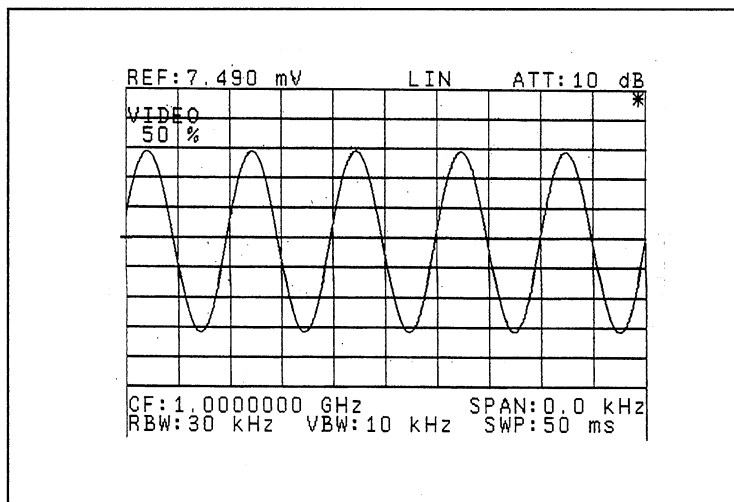

Figure 7-4 Using a VIDEO trigger to display a waveform

5 EXT

Use an external trigger to control the sweep. The trigger signal applied to the rear panel EXT TRIG connector should be a TTL signal.

Either the High to Low transition, falling edge (-), or the Low to High, rising edge (+) can be chosen for triggering.

6 SLOPE
+/-

Select the polarity of the external signal or VIDEO trigger used for triggering. + selects the rising edge, - selects the falling edge for the trigger point.

(2) Detector mode setup

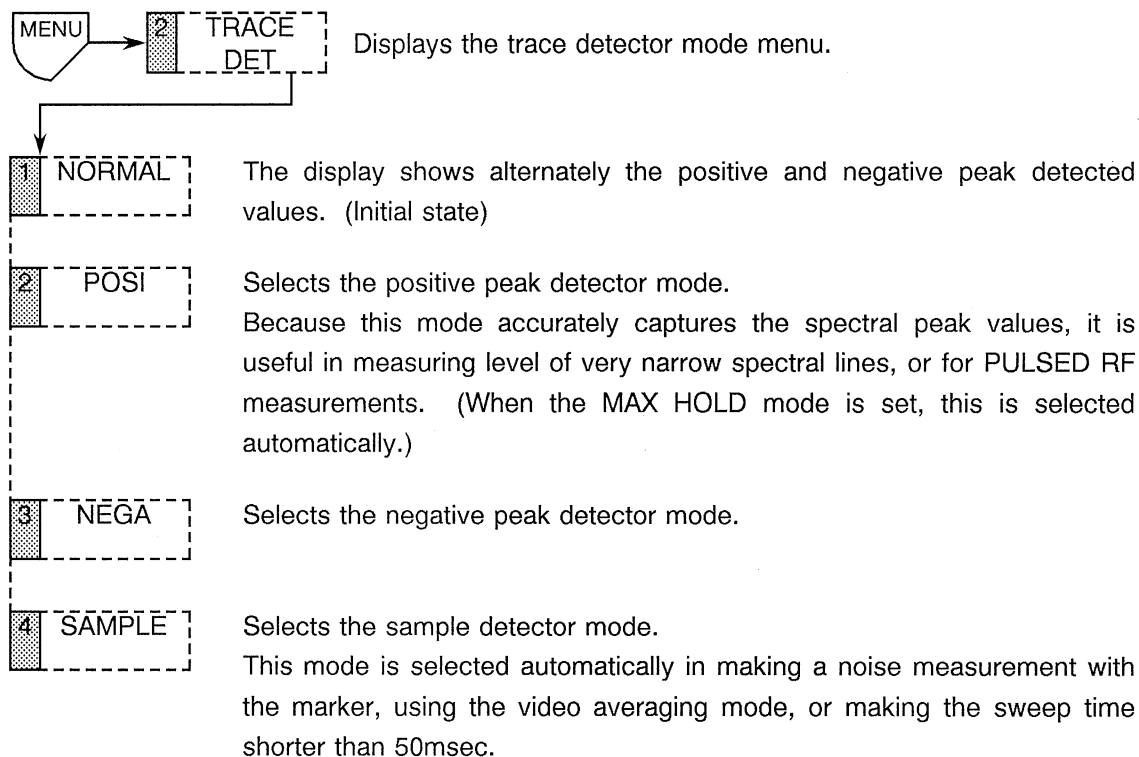

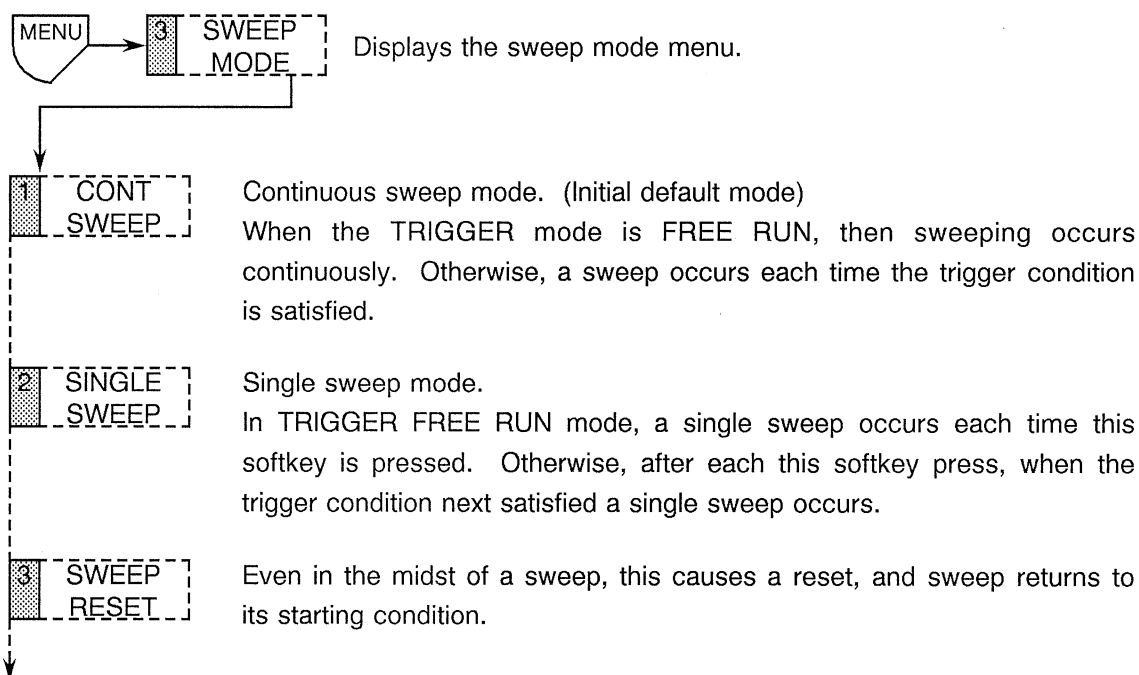

(3) Sweep mode setup



4 MANUAL SWEEP

Manual sweep mode.



A marker appears on the screen, and sweeping occurs only from the marked frequency. The sweep point frequency can be changed with the numeric key and units keys, the   step keys, or the data knob .

5 WINDOW SWEEP

Conduct sweeps inside a measurement window. When pressing this key again, window sweep can be canceled.

6 MK PAUSE ON/OFF

Select ON to first enter a PAUSE time.

When ON is selected, a marker appears on the screen, and the sweep is stopped for PAUSE seconds on the marker position. The pause period can be set between 100 ms and 1000 sec with the numeric key and units keys,   step keys, or the data knob .

Selecting OFF takes the analyzer out of the marker pause mode.

CAUTION

MK PAUSE does not operate in ZERO SPAN mode.

(4) Sound monitor mode setup

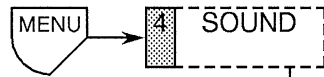

A marker is displayed on the screen. The AM or FM signal can be demodulated at the marker position, and the audio signal can be output from an internal speaker.

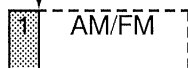

CAUTION

When the setting of the analyzer is TV monitor screen, the TV audio demodulation function takes precedence over the SOUND function. Therefore, the SOUND function is disabled.

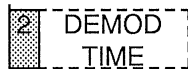

Select the AM or FM demodulator.
Set RBW less than or equal to 3kHz.



Set the demodulation time and duration. A marker appears and the sweep is stopped at the marker point for the demodulation duration selected. The duration can be set between 100 ms and 1000 sec with the numeric key and units keys,   step keys, or the data knob .

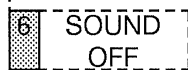

Disable the sound monitor.

(5) Display line setup

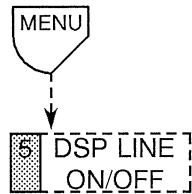

The display line is a horizontal cursor line that runs across the screen for making level comparisons. It can be set between the reference level and

the lowest level with the numeric key and units keys,

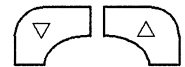

step keys, or the data knob .

In the OFF setting, the display line disappears from the display.

(6) Display color setup

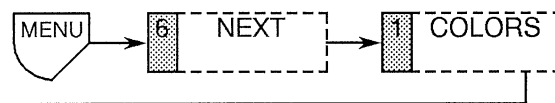

Select any one of display colors from 1 to 4, or five types of display colors defined by user.

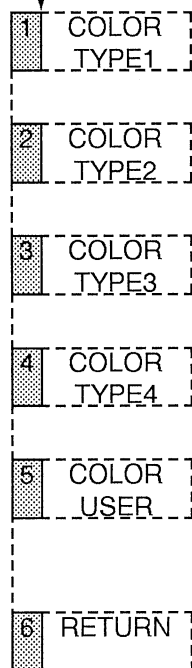

Select the designated color type 1. (Initial default mode)
Display the color using the designated color type 1.

Display the color using the designated color type 2.
(This type is best suited for using outdoors.)

Display the color using the designated color type 3.

Display the color using the designated color type 4.
(optimum color for image at monochrome printer outputting)

Display the color defined by user.
For the definition of display color, refer to the procedure (7) described later.

Return to the previous menu.

(7) Definition of display color

User can define the display color appropriately. Select the parameter to be changed (see Table 7-2), and control the color with 3 original colors (RGB).

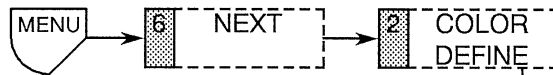

Press the keys in order, the color definition window screen (see Figure 7-5) is displayed.

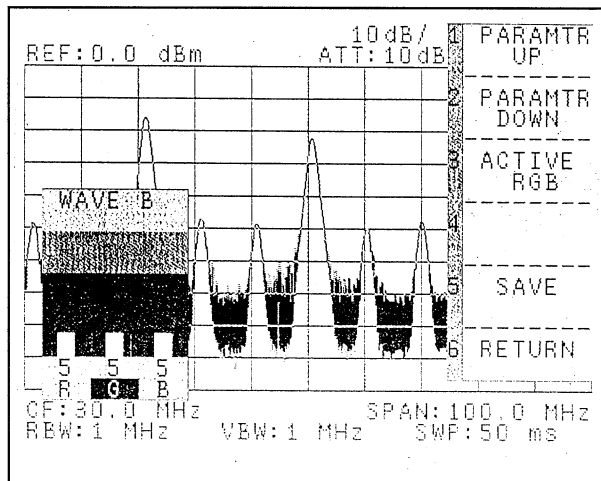
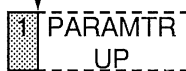

Figure 7-5 Color definition window screen





Select the parameter to be changed in accordance with the table Number (see Table 7-2). Pressing this key cause the parameter to be changed to turn in No. 1, No. 2, No. 3, ... in order.

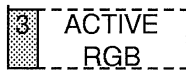

Select the parameter to be changed in accordance with the table Number (see Table 7-2). Pressing this key cause the parameter to change to turn in ... No. 3, No. 2, No. 1, ... in order.



Switch the RGB for the color adjustment window (see Figure 7-6). The RGB is changed with this key. The strength of each RGB can be changed with   step keys or data knob  by confirming

the display colors on the second line in the color adjustment window (see Figure 7-6).

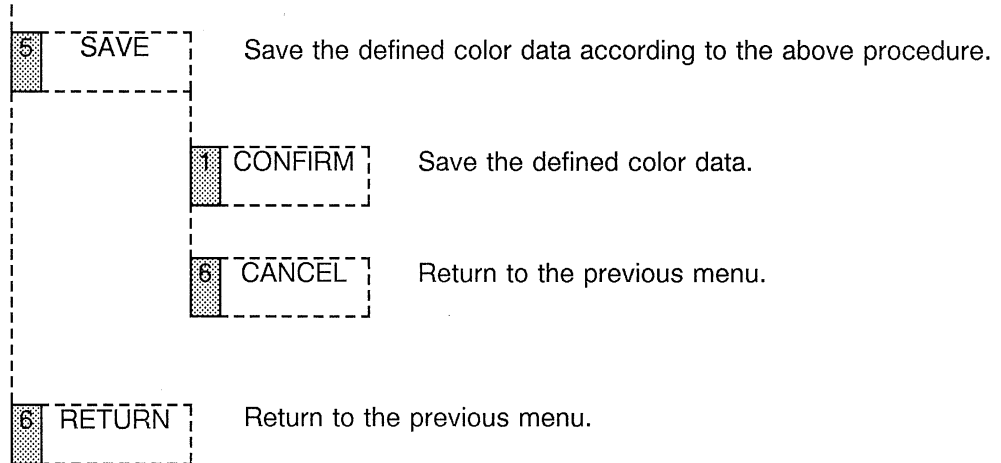

Table 7-2 Color table mode

Table No.	Parameter	Description
1	WAVE A	Waveform A color
2	WAVE B	Waveform B color
3	WAVE A & B	Color mixed with waveform A and B
4	NORMAL MARKER	Normal marker color
5	DELTA MARKER	ΔMarker color
6	MARKER NORM & DLT	Color mixed with normal marker and ΔMarker
7	SCALE LINE	Scale line color
8	SCALE BACK	Background color for scale
9	BACK GROUND	Background color other than scale
10	DISPLAY LINE	Display line color
11	SCALE & DL	Color mixed with scale line and display line
12	LIMIT LINE	Limit line color
13	TRIGGER LEVEL	Arrow color for trigger level
14	ANNOT CHAR	Standard character color (center frequency, frequency span, etc.)
15	MARKER DATA	Marker data color
16	ACTIVE DATA	Active data character color
17	SOFTMENU WINDOW	Background color for software menu
18	SOFTMENU NUMBER	Number character color of software menu
19	SOFTMENU CHAR	Standard character color of software menu
20	SOFTMENU ACT-CHAR	Active character color of software menu
21	SOFTMENU NUM-BACK	Background color for number character of software menu
22	MARKER DATA-BACK	Background color for marker data character
23	COUPLE DATA-BACK	Character background color at manual setting of couple data
24	MEAS WINDOW	Measurement window color
25	MEAS W-FRAME	Measurement window frame color
26	WAVE A & MW	Waveform A color in measurement window
27	WAVE B & MW	Waveform B color in measurement window
28	WAVE A & B & MW	Color mixed with waveform A and B in measurement window
29	EDITOR WINDOW	Editor window color
30	DELAY WINDOW	Delay sweep window color
31	SCALE & DW	Color mixed with delay sweep window and scale
32	PK LIST TITLE	Background color for peak list (Multi marker list) title
33	PK LIST DATA	Background color for peak list (Multi marker list) data
34	MULTI MARKER	Multi marker color

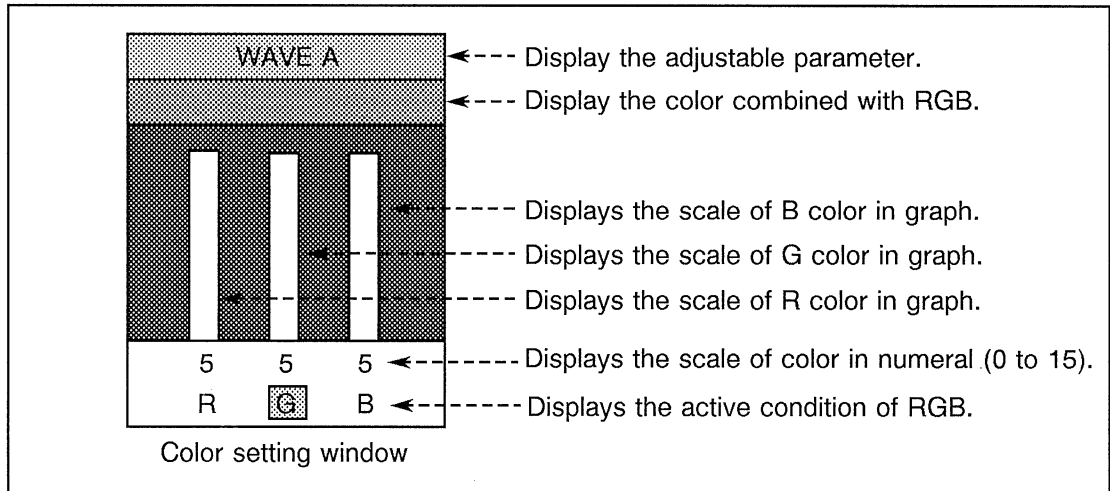

Figure 7-6 Color setting window

7.2 TRACE Functions

The TRACE key is shown in Figure 7-7.

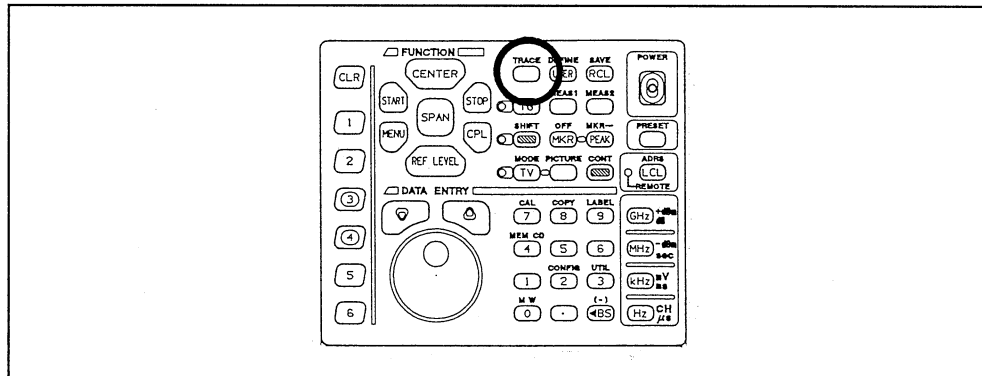

Figure 7-7 Trace key on front panel

The analyzer provides two trace memories, A and B.

The A/B trace memory has two modes: in WRITE mode the new data from each sweep writes over the data from the previous sweep. In the VIEW mode the data representing a spectrum or waveform can be held and displayed.

If wave form data is stored to the B memory then various waveform comparisons become available.

The trace display is composed of an array of display points, 701 horizontally in each line and 341 lines in all.

The Input RF signal first goes through the RF/IF section, then either a LOG or LINEAR amplifier. Next it is detected and then input to an analog to digital converter. The digital data is then stored in the trace memory, where it can be processed by the CPU, and finally displayed.

Four modes of the trace key function are shown below.

1. Trace mode
2. Averaging mode
3. Operation mode
4. Normalizing mode

7.2.1 Trace Modes

(1) Modes for the A trace memory

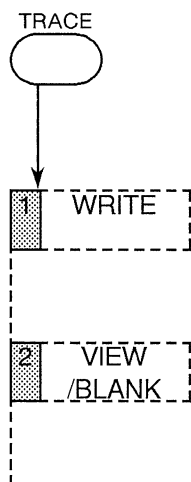

Displays trace mode softmenu.

When softmenu disappears (display *), the trace A mode is switched to WRITE or VIEW alternately by pressing this key.

Go into the WRITE mode. In this mode the new data from each sweep both updates the A trace memory and is displayed on the screen at the save time.

Toggle the A trace between VIEW (display) and BLANK. When this is pushed, the A trace leaves the normal WRITE mode. To return to the WRITE mode press  again.

VIEW mode : Stop the Write updating operation; and hold and display the contents of the A memory at the instant of the VIEW mode selection.

BLANK mode : Erase the trace data from the display; but hold the contents of the A memory at the instant of the BLANK mode selection. The trace can be redisplayed by again selecting VIEW mode.

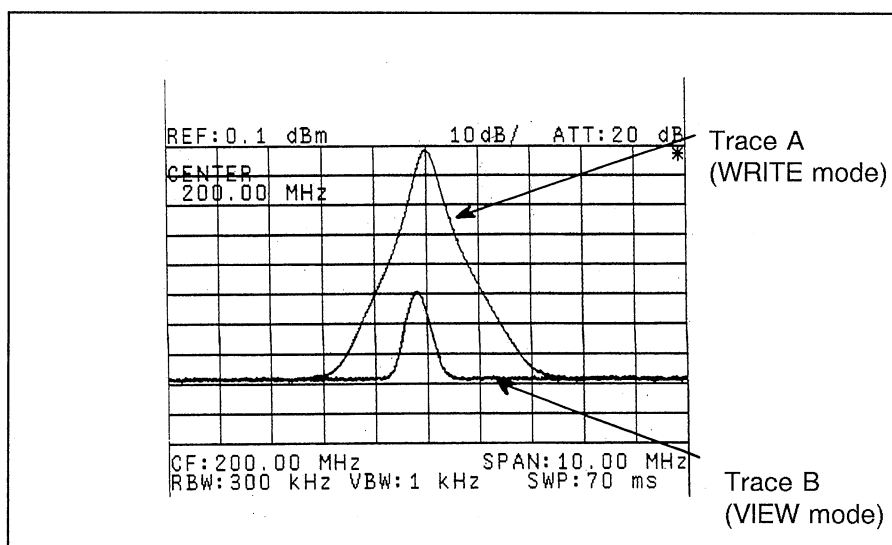
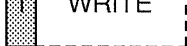

Figure 7-8 WRITE and VIEW trace modes

3 MAX HOLD

Go to the MAX HOLD mode. (Not available for the trace B.)

On each sweep, compare the new data for each horizontal (frequency) point with the previous data. Store and display the level with the larger value. Thus the display accumulates the maximum values for each point in the time series.

When this key is pressed again or the softkey  is pressed, the MAX HOLD mode can be canceled.

CAUTION

Selecting this mode automatically forces the positive PEAK detector mode.

4 MIN HOLD

Go to the MIN HOLD mode. (Not available for the trace B.)

On each sweep, compare the new data for each horizontal (frequency) point with the previous data. Store and display the level with the smaller value. Thus the display accumulates the minimum values for each point in the time series.

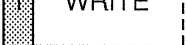
When this key is pressed again or the softkey  is pressed, the MIN HOLD mode can be canceled.

CAUTION

Selecting this mode automatically forces the negative PEAK detector mode.

(2) Trace B modes

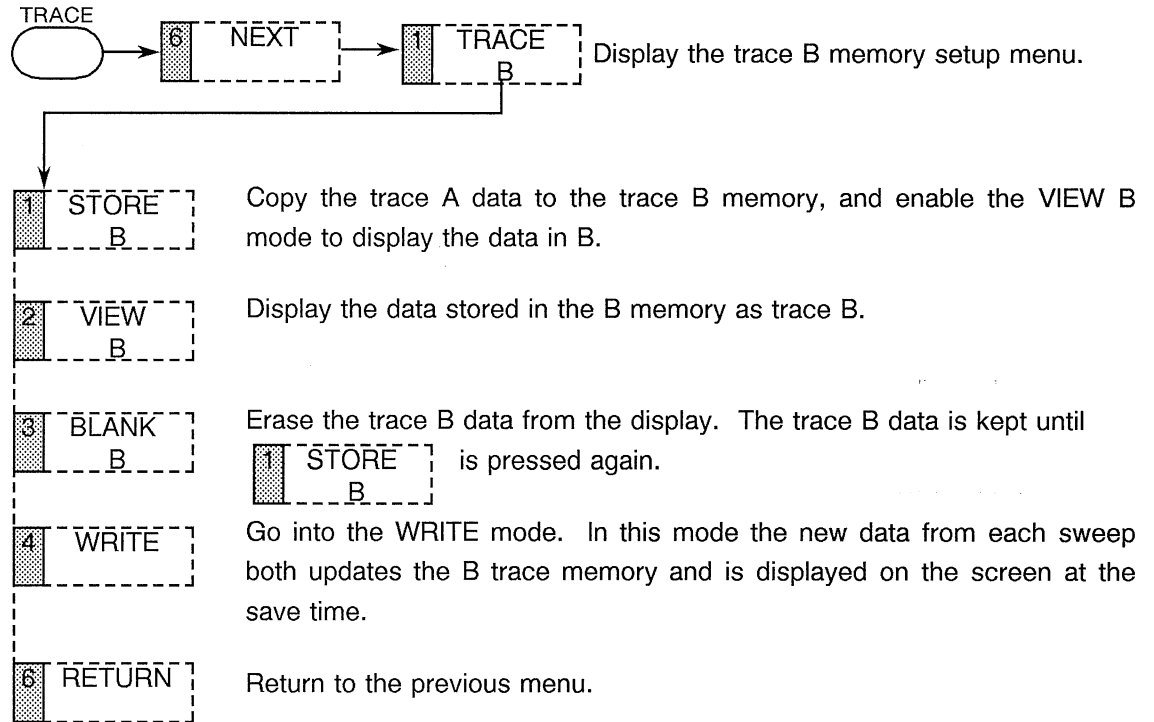

(This page has been intentionally left blank.)

7.2.2 Averaging Mode (Trace A Only)

Averaging can be used to improve S/N in a shorter time than video bandwidth filtering for noise reduction would require. With averaging it is possible to recover signals buried in noise, or quantified signals with a random component.

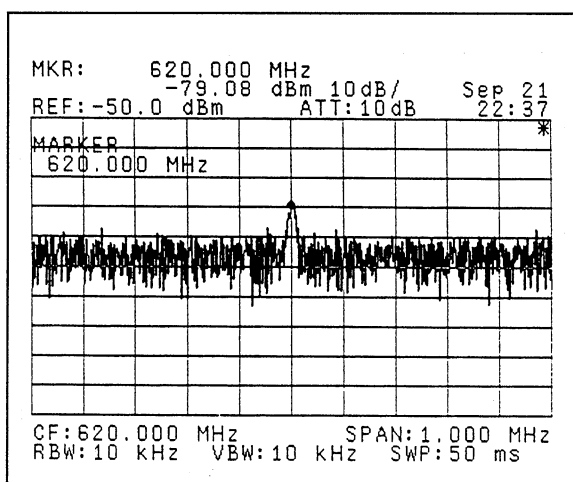

Figure 7-9 No averaging

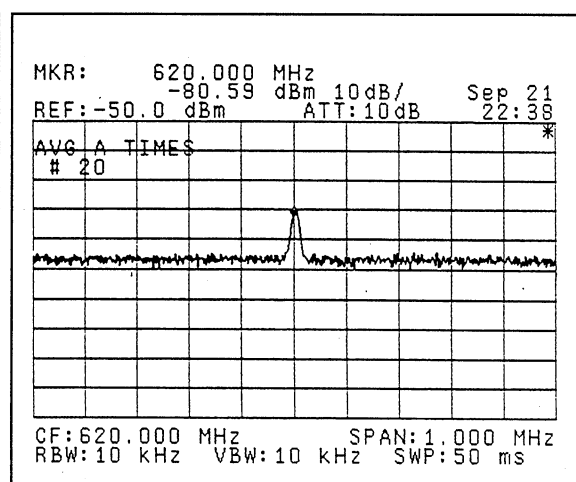
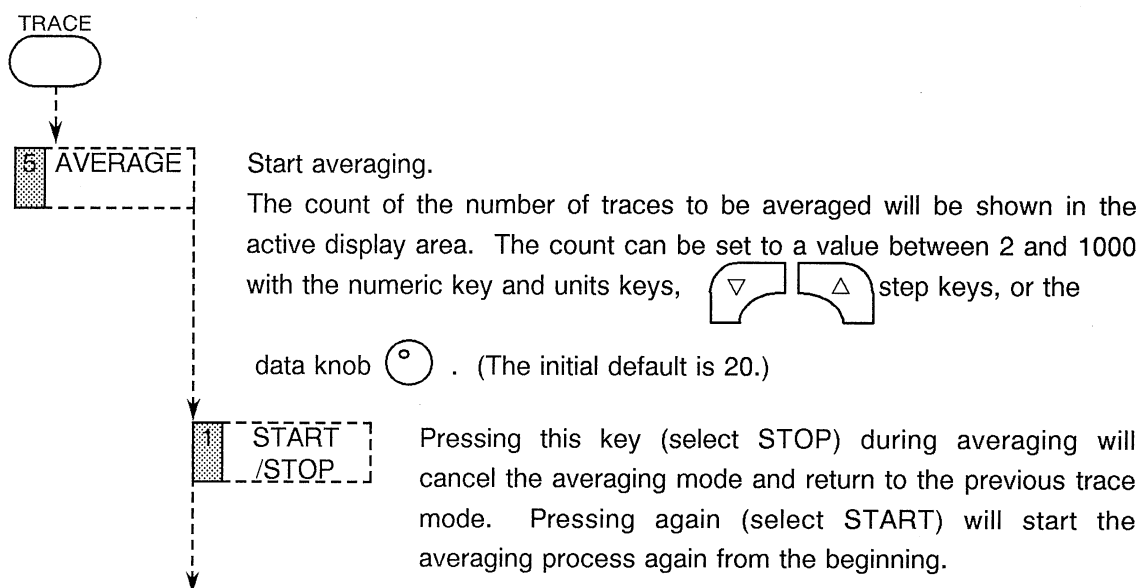

Figure 7-10 Averaging 20 times

CAUTION

Selecting averaging mode automatically forces the SAMPLE detector mode.



2 PAUSE
/CONT

Pressing this key (select PAUSE) during averaging will pause the operation. The current averaging count will be seen at the top left of the display. Pressing again (select CONT) will continue the averaging from the point at which it was paused.

3 AVG TIME
1/CONT

When CONT is set, even after the desired averaging count has been reached, averaging will be repeated continuously using algorithm 2 for updating the data. In the 1 (single) mode, as soon as the desired averaging count has been reached the analyzer will automatically leave the averaging and go to the VIEW mode.

Averaging algorithms

Algorithm 1: ($N \geq n$)

$$\bar{Y}_n = \text{Sigma}/n$$

Algorithm 2: ($N < n$)

$$\bar{Y}_n = ((N-1) \cdot \bar{Y}_{n-1})/N + Y_n/N$$

n	: Current averaging count
N	: Averaging count specified
Y_n	: Trace data for nth average
\bar{Y}_n	: Averaged data for nth average
\bar{Y}_{n-1}	: Averaged data for n-1th average
Sigma	: Sum of all the data up to the nth sweep

5 TRC DET
SMPL/POS

Selects to execute averaging in the sample detection mode or in the peak detection mode.

6 RETURN

Return to the previous menu.

7.2.3 Calculation Modes

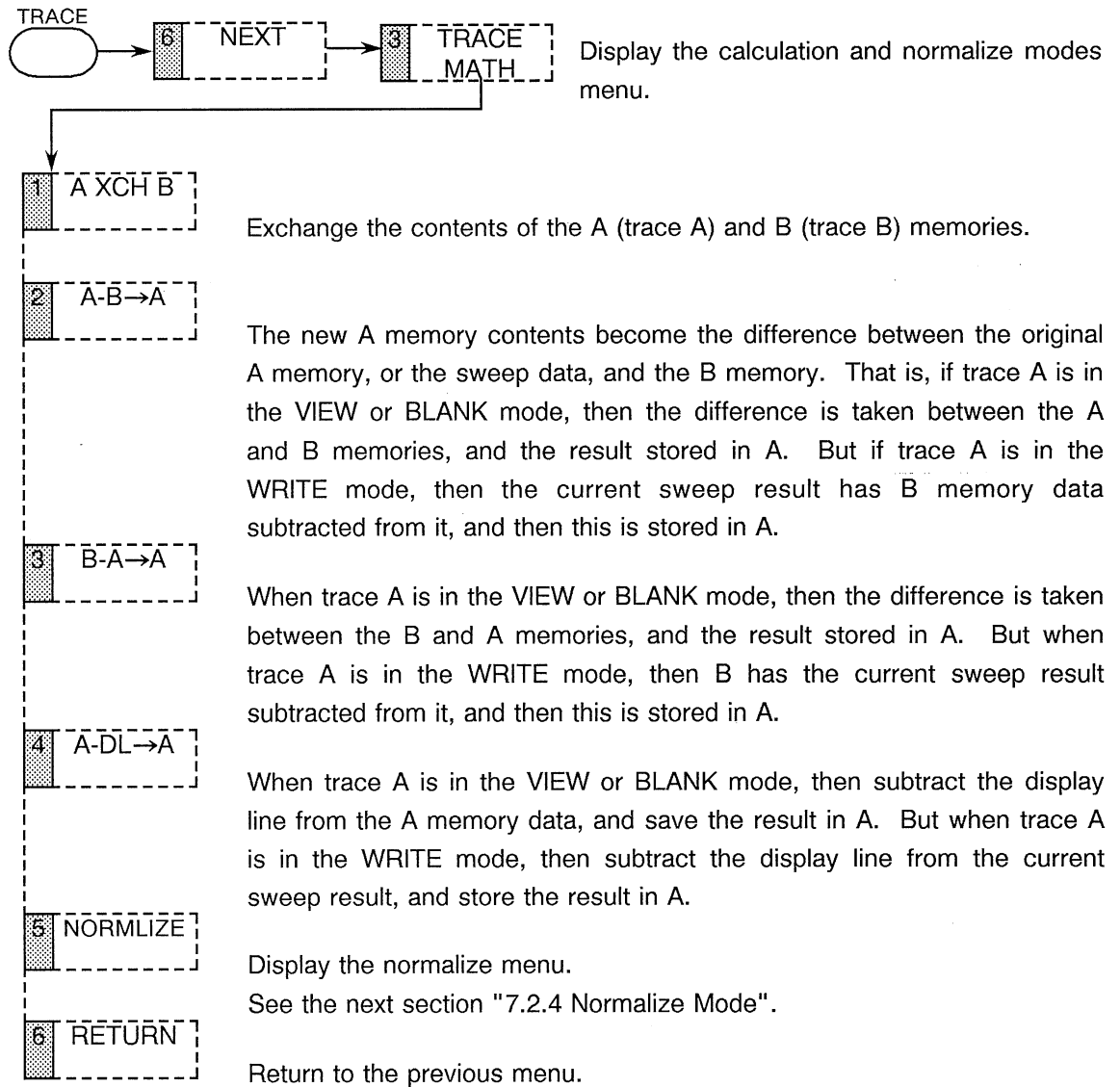

7.2.4 Normalize Mode (Trace A Only)

The normalize function makes waveform comparison easy by treating reference signal as a display line data. The normalize is operated in the following procedure.

- ① Display the display line data.
- ② Store the reference signal into the memory as CORRECTION DATA and establish the value as display line.
- ③ Relative difference between the CORRECTION DATA and the input data is displayed on screen by inputting the comparing signal. (Normalize ON)

CAUTION

When executing the normalize, always be sure to display the display line. If the normalize is executed without displaying the display line, the level display value shows the absolute value (dBm, etc.) from the reference value and the relative value (dB) is not displayed.

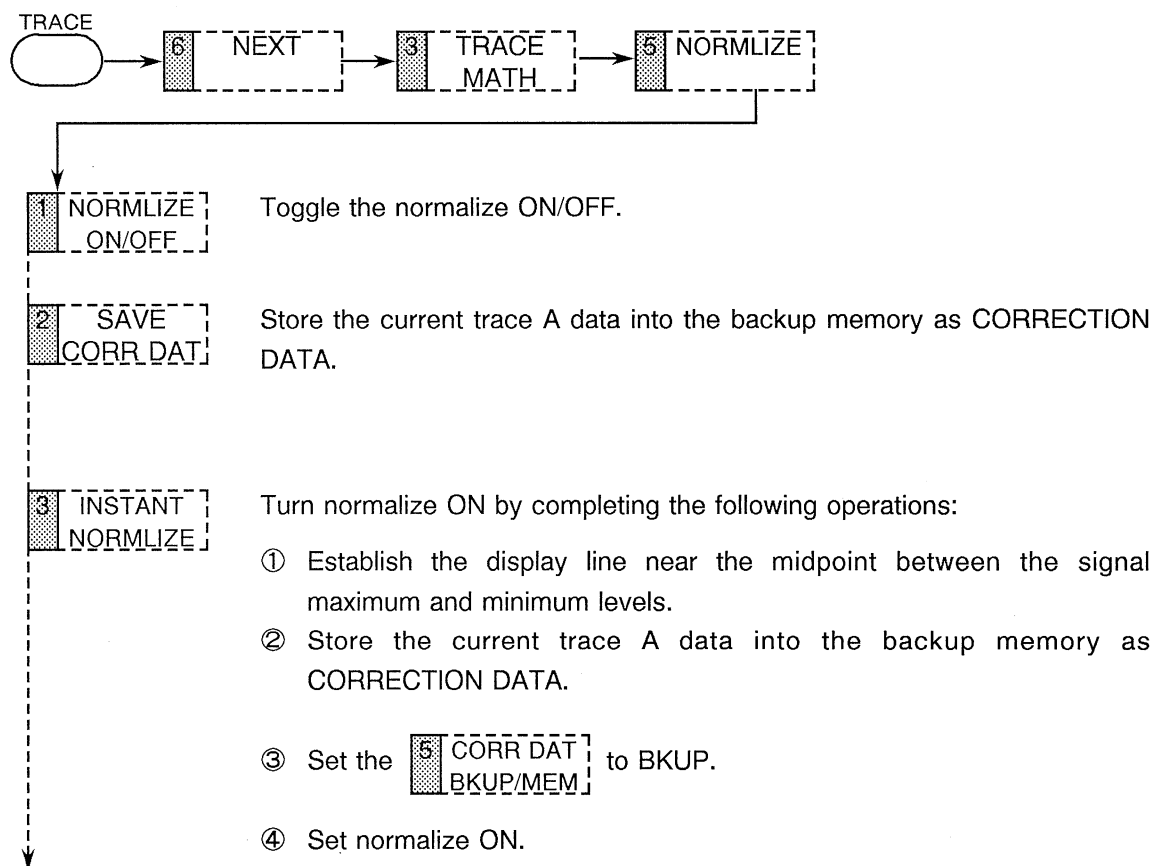

5 CORR DAT
BKUP/MEM

Select the CORRECTION DATA for normalizing.

BKUP: A Normalize is performed using CORRECTION DATA ,which is saved in the backup memory of the spectrum analyzer, if this mode and Normalize are activated.

In this mode, the CORRECTION DATA is saved in the backup memory of the spectrum analyzer when recalling the data from the memory card (however, a few seconds are required to save).

MEM: A Normalize is performed using CORRECTION DATA ,which is saved in the memory of the spectrum analyzer, if this mode and Normalize are activated.

In this mode, the CORRECTION DATA is saved in the memory of the spectrum analyzer when recalling the data from the memory card.

(Note) The data in this memory is lost when you turn off the power of the spectrum analyzer.

When you wish to turn on Normalize in this mode after powering on, recall CORRECTION DATA from the memory card.

6 RETURN

Return to the previous menu.

**SPECTRUM ANALYZER
OPERATION MANUAL**

(This page has been intentionally left blank.)

7.3 Marker Functions

This function is used to place the normal marker and the Δ marker on the on-screen waveform and to display the frequency and the level data of that point.

The Marker key is shown in Figure 7-11.

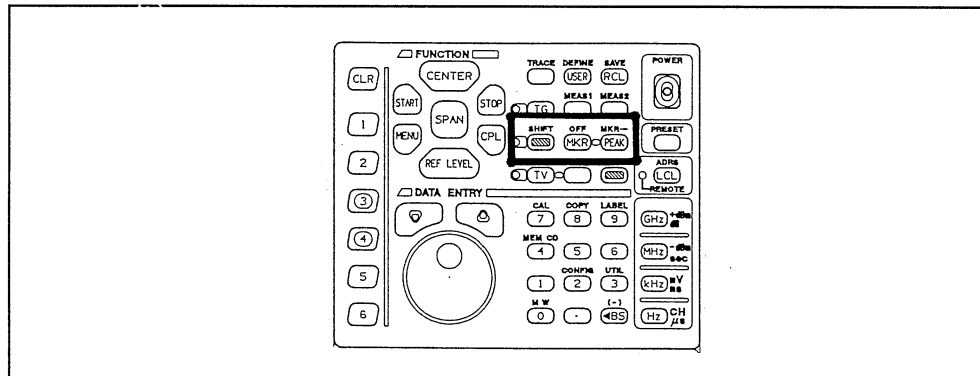
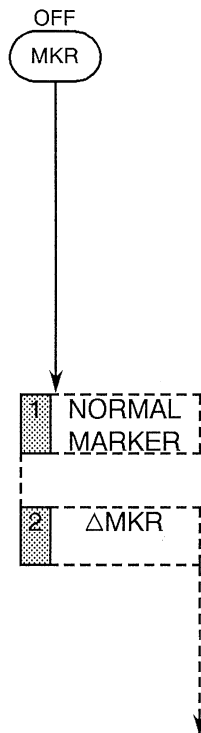





Figure 7-11 The MARKER section on front panel

7.3.1 Marker ON

- (1) Both normal marker and Δ marker





Pushing MKR turns the marker ON: the marker (Symbol: \blacklozenge) is shown on the trace, and the marker frequency and level parameters are displayed at the top left of the screen.

The marker can be moved with the numeric key and units keys, the   step keys and the data knob .

When softmenu also disappears (display *), the marker is turned ON and can be moved.

Select the normal marker (\blacklozenge) for for setup or manipulation.

Display the Δ marker (Symbol: \blacklozenge), initially at the same place as the normal marker. The marker area will begin showing the relative difference between the frequency and level of the normal marker and the Δ marker.

Data input for the frequency difference between the two markers can be made with the numeric key, the   step keys and the data knob . Doing so, the Δ marker becomes fixed, and the normal marker (\blacklozenge) moves away from it by the specified frequency difference.

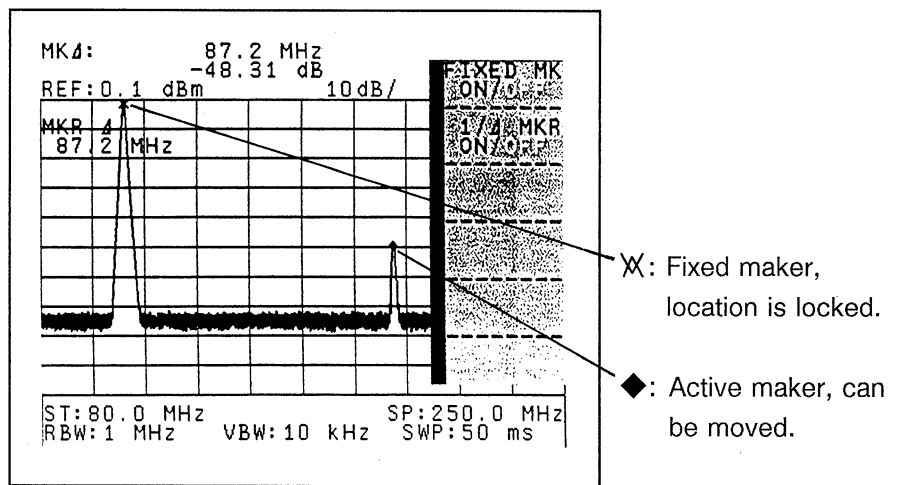

Figure 7-12 Active marker and fixed marker

1 FIXED MK
ON/OFF

Store the current Δ marker frequency and level, and fix the marker at that position on the screen. Then even if the center frequency or reference level is changed, the next time this function is turned on the stored marker data will be displayed as reference data for the frequency and level. (See Figure 7-12.)

2 1/Δ MKR
ON/OFF

Select ON to display the reciprocal of the Δ marker data. This function is useful for finding the modulation frequency of a signal being viewed in zero span mode.

3 %

When vertical axis represents linear scale, show the voltage comparison in the active marker level (\blacklozenge) depending on the Δ marker level (X) with % unit on the marker area.

For example, when a Δ marker is 100 mV and an active marker is 10 mV, 10 % is displayed.

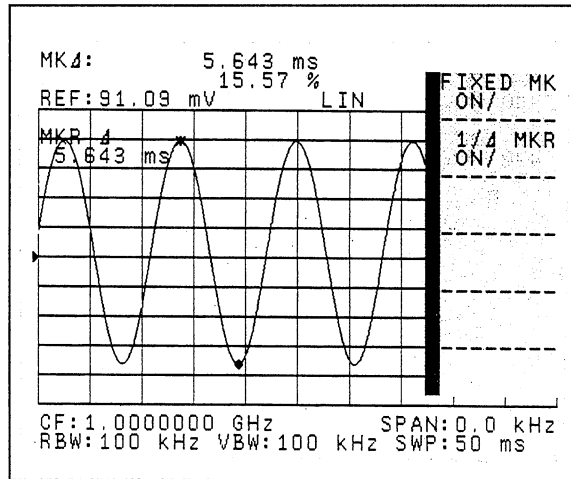
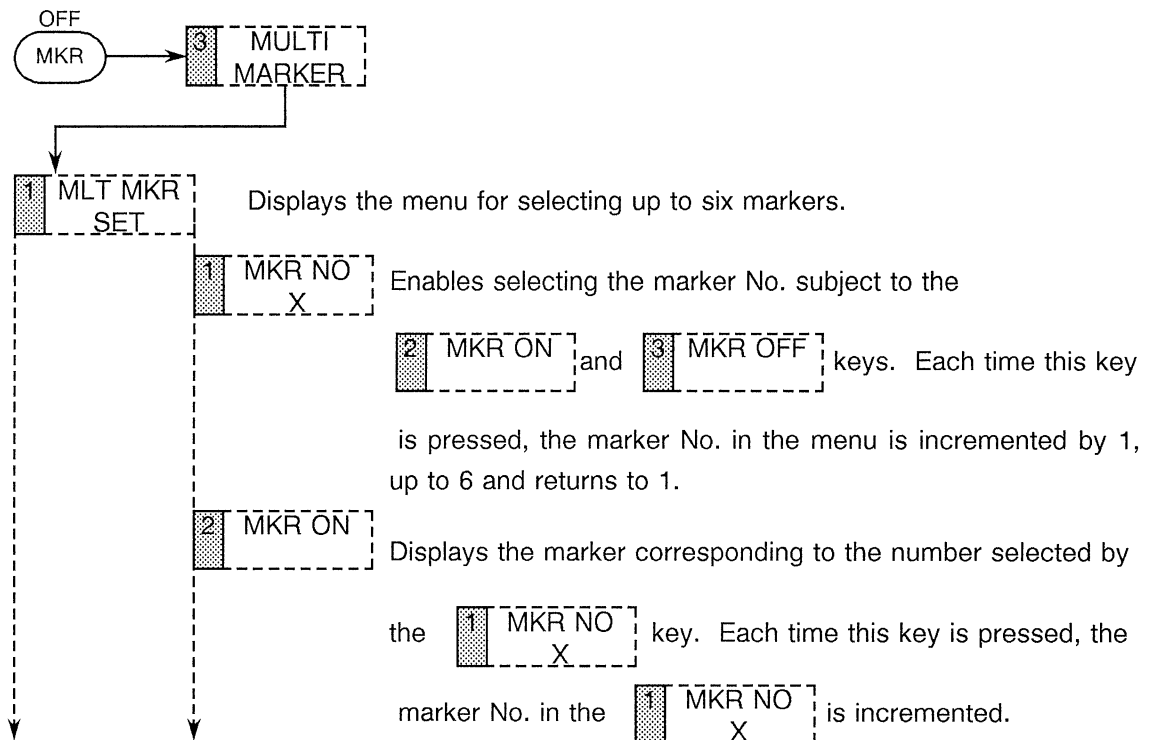

Figure 7-13 Δ Marker level % display

(2) Multi Marker

In this mode, a maximum of six markers can be displayed. This enables simultaneous measurement of the frequency and level at multiple points.

One of the six markers always becomes an active marker, which can be moved by the numeric keys, [STEP] key, and [DATA KNOB] key.



3 MKR OFF	<p>Cancels the display of the marker corresponding to the number selected by the 1 MKR NO X key. Each time this key is pressed, the marker No. in the MKR NO X is decremented.</p>
4 ACTIVE MKR	<p>Changes the active marker among the displayed markers. Each time this key is pressed, the marker No. in the "MKR NO" menu is changed in ascending order, indicating which marker is active.</p>
6 RETURN	<p>Returns to the previous menu.</p>
2 MKR LIST ON/OFF	<p>Set to ON to display the list of frequencies and levels of the displayed markers. (See Figure 7-13a and Notes on List Display.)</p>
3 PK LIST LEVEL	<p>Displays maximum six markers and the list of levels at the waveform peak points in the order of marker No.</p>
4 PK LIST FREQ	<p>Displays maximum six markers and the list of frequencies at the waveform peak points in the order of marker No.</p>
5 MLT MKR RESET	<p>Cancels the multiple marker display and displays the No. 1 marker only.</p>
6 MLT MKR OFF	<p>Cancels the marker list display as well as displayed markers No. 1 to No. 6.</p>

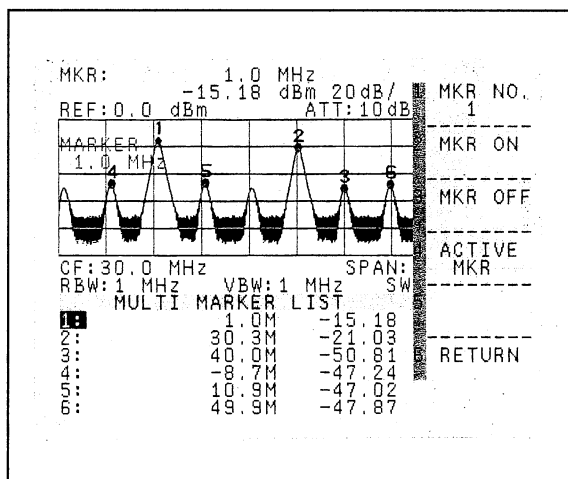
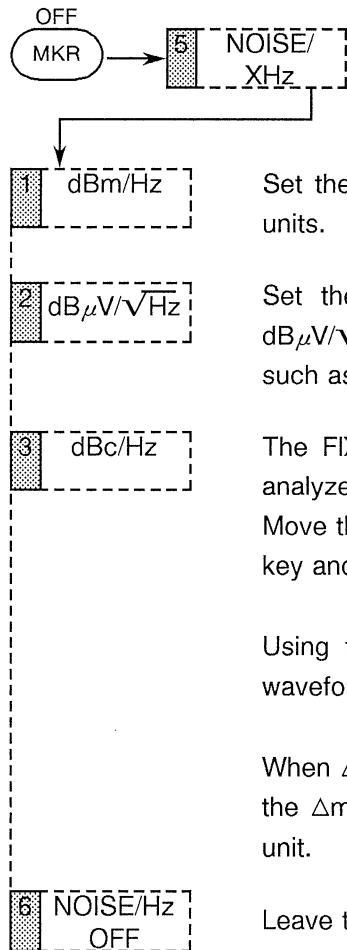

Figure 7-13a Sample of Multi Marker List Display

[Notes on List Display]



1. When the soft menu display is active, the unit is simplified for the list display.
 - Case of horizontal axis frequency display: GHz → G, MHz → M, kHz → k, Hz → H
 - Case of level display in units of dBm, dB μ V, dB μ Vemf, dBmV, and dBpW: All units are omitted. (See the standard level unit.) Case of volt and watt: Units are displayed.
2. Displays of dB/div are changed as follows:
 - 10dB/div → 20dB/div
 - 5dB/div → 10dB/div
 - 2dB/div → 4dB/div
 - 1dB/div → 2dB/div
3. The PEAK Δ Y div setting range is changed as follows:
 - 0.1 to 10.0 → 0.05 to 5.0



Detector mode is automatically replaced with the sample mode and the following three menus for Noise/Hz measurement mode will be displayed.

1 dBm/Hz Set the reference level to dBm and calculate the noise level in dBm/Hz units.

2 dB μ V/ \sqrt Hz Set the reference level to dB μ V and calculate the noise level in dB μ V/ \sqrt Hz units. This key is available for the noise level measurement such as a TV broadcast signals, etc.

3 dBc/Hz The FIXED Δ marker is displayed at the active marker location and the analyzer goes into the Carrier Noise Ratio (dBc/Hz) measurement mode. Move the marker to the desired point to be measured using the numeric key and units keys, the  step keys, or the data knob .

Using the dBc/Hz mode, an easy operation can be made to obtain a waveform signal.

When Δ marker display is set in advance, show the voltage comparison in the Δ marker level on that position depending on the Δ marker level with unit.

6 NOISE/Hz OFF Leave the Noise/Hz measurement mode.

[Display marker switching]

While making noise measurements, if the display line is being displayed, you can switch back and forth between a display of the noise level measurement result and the normal marker data display.

When the active marker is Below the display, then display the noise measurement results.

When the active marker is Above the display line, then display the normal marker data.

(5) Marker level display switching at display line ON

This function can be used when the display line is on.

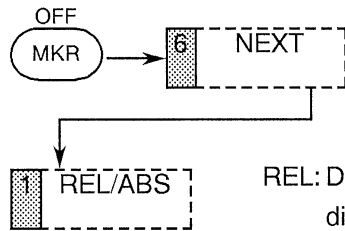

REL: Display the relative level difference between the active marker and display line. (Initial state)

ABS: Display the marker level, independent of the display line.

CAUTION

Even when REL is selected, when the Δ marker is ON, the Δ marker level data is unaffected and it continues to operate as usual.

(6) Marker movement between trace A and B

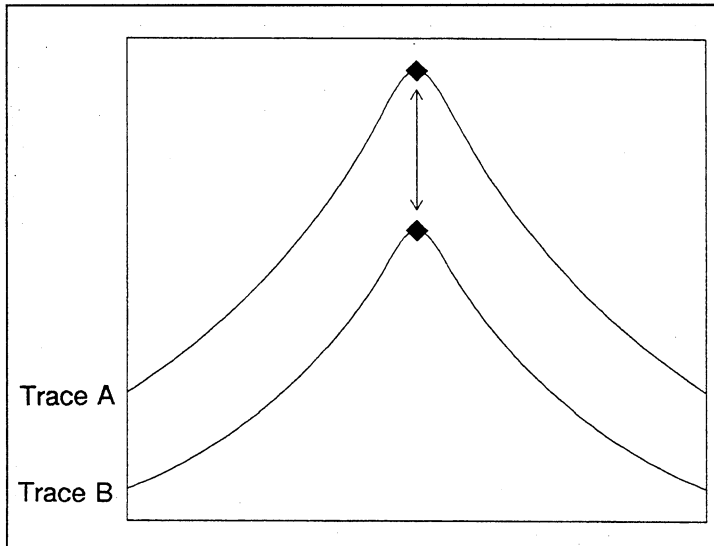

Move the active marker to the A or B waveform at 2-screen trace operation (see Figure 7-15). However, Δ marker does not move.

Figure 7-15 Marker movement between trace A and B

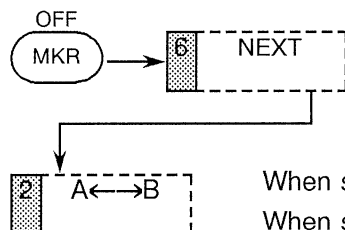

When selecting A, moves the active marker to the trace A.
When selecting B, moves the active marker to the trace B.

7.3.2 Peak Search

(1) Peak search menu

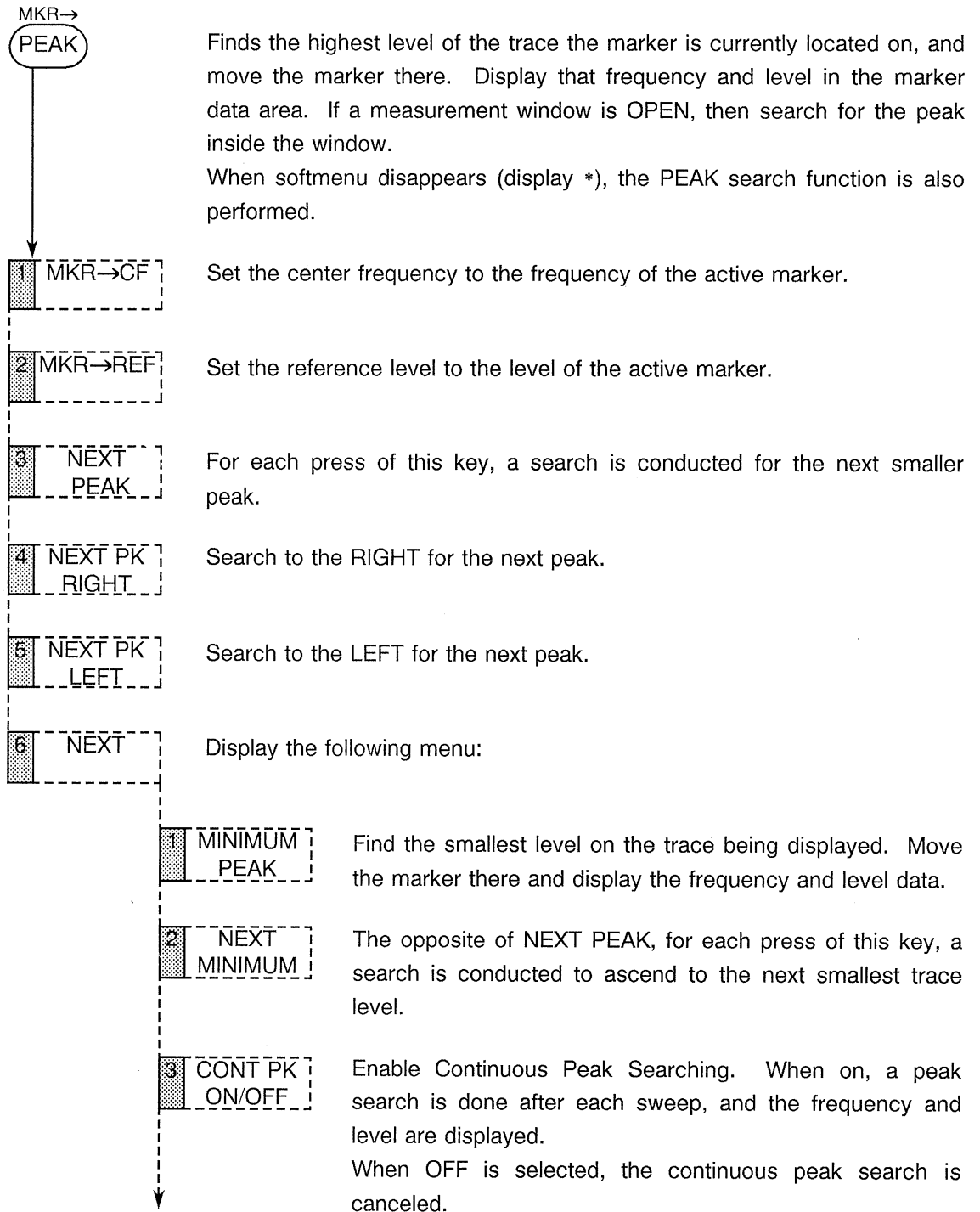

4 PEAK ΔY div	Set the amplitude condition for NEXT PEAK search. For further details, refer to the procedure (2) described later.
5 ALL/UP /LOW	Modify the peak search level. For further details, refer to the procedure (3) described later.
6 RETURN	Return to the previous menu.

(2) Amplitude condition settings for NEXT PEAK search



To execute a next peak search, set up the amplitude condition for the waveform to be searched with the numeric key and the units keys. For example, entering the value "1 div" corresponds to 1 division on the horizontal axis. In case of many waveforms shown in Figure 7-16, it is necessary to treat each signal as a single amplitude (target for next peak search) so that the next peak search is executed to find the entire waveform amplitude data.

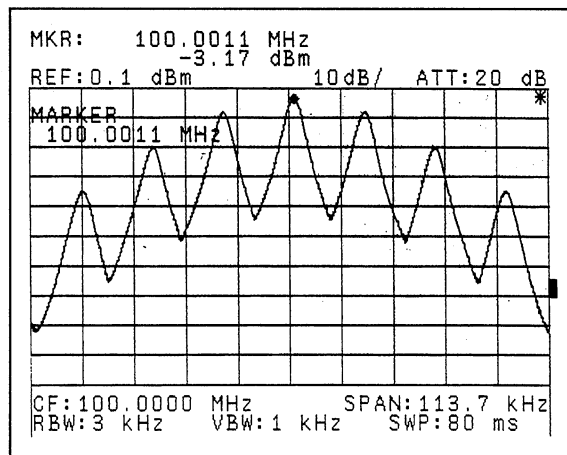

Figure 7-16 Next peak search execution

Thus the target waveform for the next peak search as a ΔY can be set by using the amplitude value (div).

[ΔY setting]

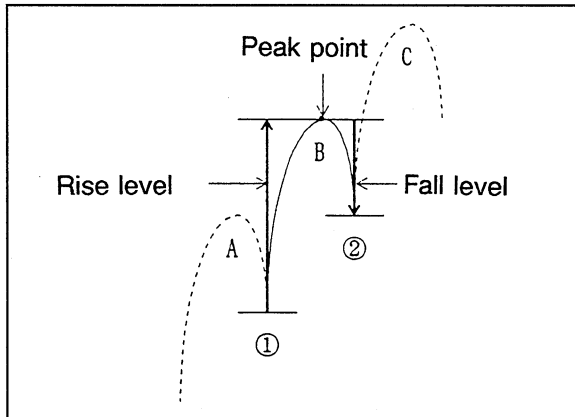

Figure 7-17 ΔY setting

The waveform B increases from the point ① and decreases from the highest priority point (peak) to the point ②.

If the value for ΔY is set even much smaller than the rise/fall levels, the waveform B will be an object for the next peak search.

If the waveform amplitude data to be measured is much larger than the level of ΔY which has been set, the waveform data is always an object for peak search.

(3) Modifying the peak search level

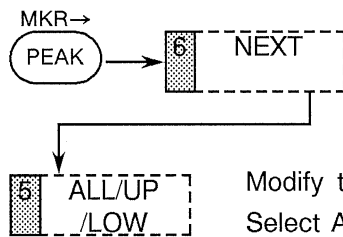

Modify the reference level of the next peak search with the display line. Select ALL to search the entire waveform data with the next peak search. (Initial state)

Select UP to search the level above the display line with the next peak search (see Figure 7-18), and LOW for the level below (see Figure 7-19).

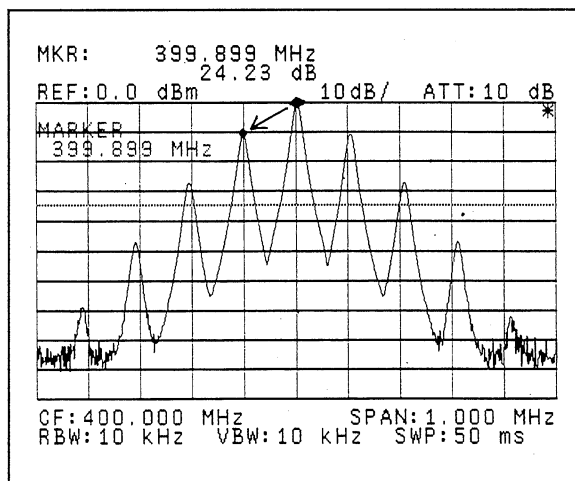

Figure 7-18 UP setting

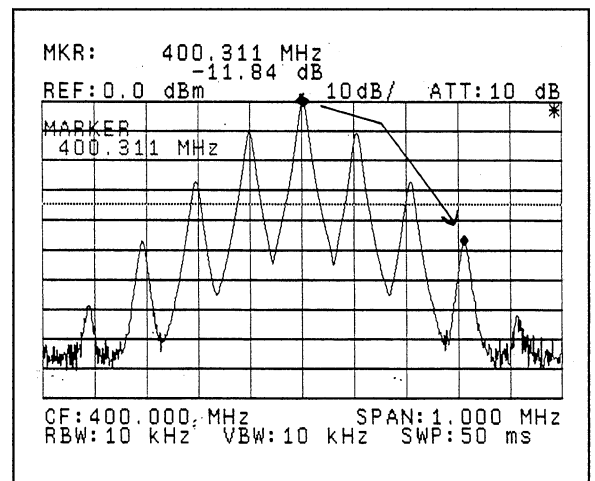
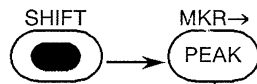

Figure 7-19 LOW setting

7.3.3 MARKER →(Marker to)

The data at the current marker point is moved to the data of some other function (frequency, level, or Δ).



1 MKR→CF

Set the center frequency to be the active marker frequency.

2 MKR→REF

Set the reference level to be the active marker level.

3 MKR Δ →
SPAN

Set the frequency span to be the Δ marker frequency.

4 MKR→
CF STEP

Set the center frequency step size to be the active marker frequency.

5 MKR Δ →
CF STEP

Set the center frequency step size to be the Δ marker frequency

6 NEXT

Display the following (next) menu.

1 MKR Δ →CF

Set the center frequency to be the Δ marker frequency.



2 MKR→
MKR STEP

Set the center marker step size to be the active marker frequency.

3 MKR Δ →
MKR STEP

Set the marker step size to be the Δ marker frequency

4 MKR STEP
AUTO/MNL

When MNL is selected, the step frequency of marker point can be specified by using the   step keys.

When AUTO is selected, the step frequency indicates 1 div on the horizontal axis.

6 RETURN

Return to the previous menu.

7.3.4 Marker OFF

Erase all markers from the display; if there are any marker related or dependent functions active, set them OFF to disable them.

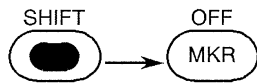

Functions which will be turned off are:

1. Counter
2. Noise/Hz
3. Marker pause
4. Sound
5. Signal track
6. Manual sweep
7. Continuous dB down
8. 1/ Δ marker
9. FIXED Δ marker
10. Power measurement
11. Multi marker

7.4 Measurement (MEAS) function

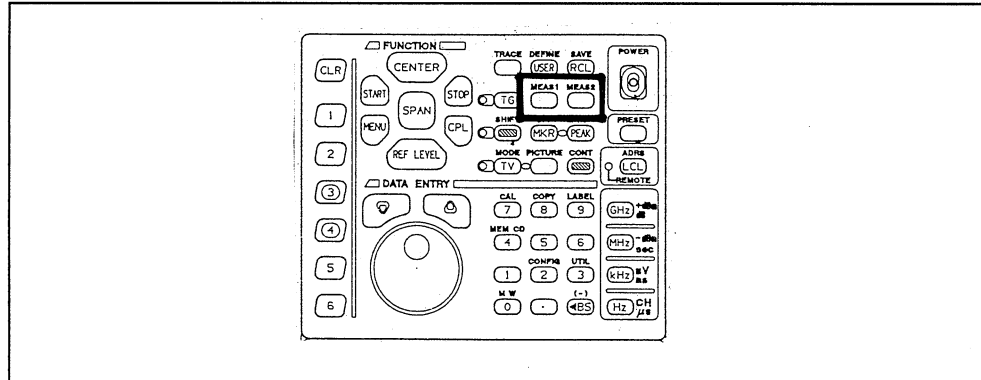

Figure 7-20 Location of measurement keys on the front panel

Measurement function consists of two keys (MEAS1 and MEAS2).

7.4.1 MEAS1

Five modes (high sensitive and frequency counter) are provided as follow.

1. High sensitive
2. Frequency counter
3. Delay sweep function
4. Gated sweep function
5. Peak list function

(1) High sensitive

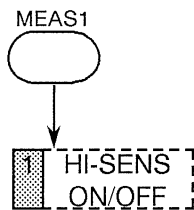

Switch the high-sensitive mode ON/OFF.

When ON is selected, the pre-amplifier is set to ON. In this case, the pre-amplifier again in each frequency has already compensated, the gain in level measurement is not required.

When OFF is selected, the pre-amplifier is set to OFF. The example of measurement to execute the internal pre-amplifier, refer to "6.3.3 Measuring Minute Signal Level".

(2) Frequency Counter

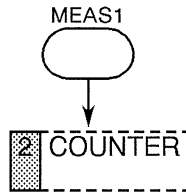

If the following inequality is satisfied, this mode enables to make a high accuracy counter measurement on the marker's existing signal frequency.

- ① Move the marker to the desired signal peak to be measured and the peak level where the marker is located is more than 25 dB above the noise level.
- ② Frequency span is more than 1 kHz and less than 500 MHz.
- ③ Set the RBW to AUTO. However, if the setting value less than the 3 kHz is entered, it should be set to 3 kHz or more.

The CNT display blinks in the setting other than the above ② and ③.

In the normal marker mode the display marker frequency is a calculated value based on the frequency axis displacement from the center frequency. In the counter mode, the accuracy is determined directly by the analyzer's reference oscillator accuracy. However, the amplitude indicates the marker's existing signal frequency.

Further, it is possible to set a resolution as small as 1 Hz for even higher accuracy. But as the counter resolution is increased the counter gate time is lengthen and the sweep becomes quite slow. The Counter cannot be used in combination with the SIGNAL TRACK mode.

The example of measurement in counter mode, refer to "6.6.2 Marker Frequency Counter Mode Frequency Measurement".

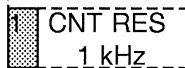

Set the frequency counter resolution to 1 kHz.



Set the frequency counter resolution to 100 Hz.

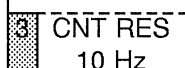

Set the frequency counter resolution to 10 Hz.

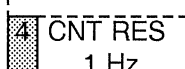

Set the frequency counter resolution to 1 Hz.



Turn the frequency counter OFF.

(3) DELAY SWEEP function

DELAY SWEEP is a function that makes a sweep start after arbitrary time from the time when a sweep trigger signal is generated, and is available only at the zero span mode.

External trigger, VIDEO trigger, TV-V trigger and TV-H trigger are used as a trigger signal source.

Figure 7-21 shows a setup mode in the DELAY SWEEP mode. Select the trigger signal source in the TRIGGER mode.

Move a window to a desirable position with DELAY POSITION and DLY SWP TIME to expand a part of the waveform.

Figure 7-22 shows the waveform of the time when the window part is expanded by executing DELAY SWEEP.

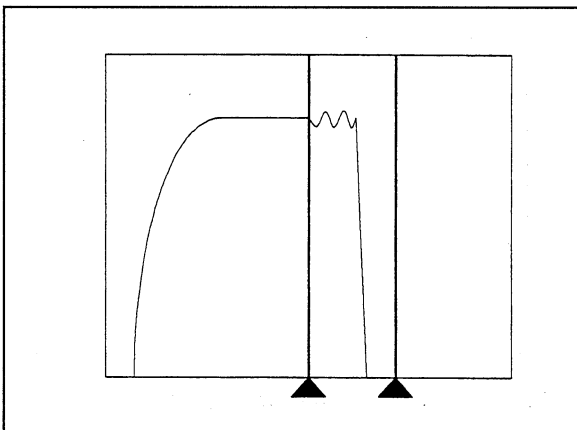

Figure 7-21 Waveform at the setup mode.
(The window is moved to a part to be expanded.)

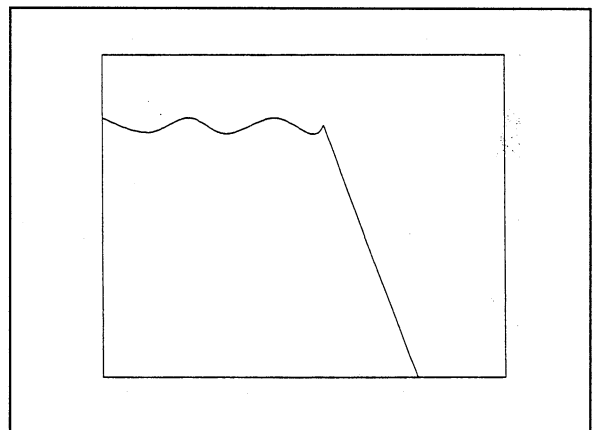
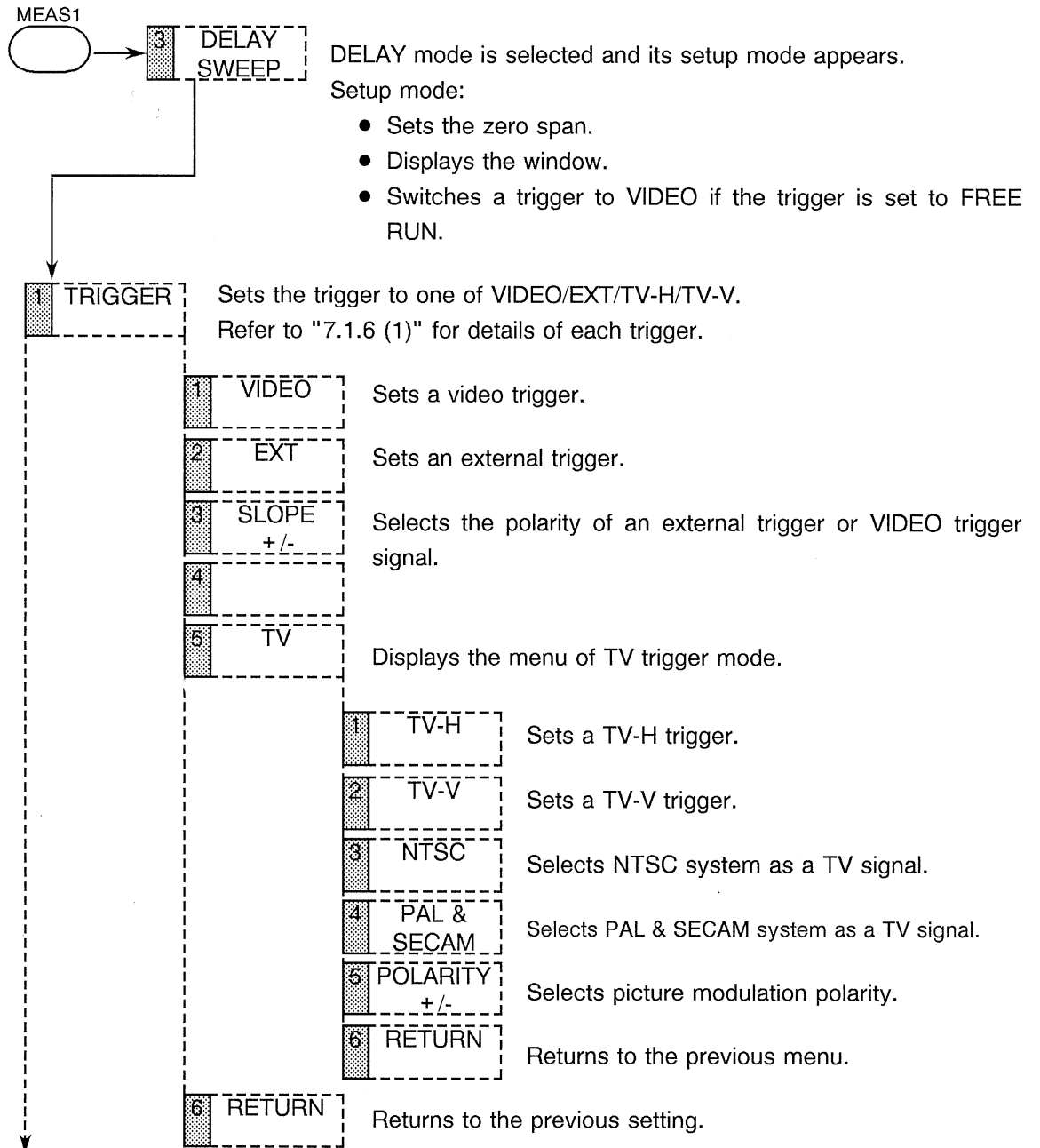

Figure 7-22 Waveform measured with DELAY SWEEP ON (The window part is expanded.)



2 DELAY POSITION

Set the the window to a desirable position by using ten keys + unit keys,



step keys and data knob.

The window is displayed when DELAY SWEEP is set to OFF. Even if the window is outside the screen, the internal data is set.

- DELAY POSITION:
1. The window moves with its delay sweep time fixed.
 2. The setting range is shown below.

Relationship between setting resolutions of the delay sweep time and the delay position

The analyzer has no OPT70 (PHS) or is under PHS mode OFF.	The analyzer is under PHS mode ON.
Delay sweep time < 20 ms 35 ns to 1.12s (Resolution of 35 ns)	Delay sweep time < 4.5 ms 35 ns to 1.12s (Resolution of 35 ns)
Delay sweep time ≥ 20 ms 50 ns to 1.6s (Resolution of 50 ns)	Delay sweep time ≥ 4.5 ms 50 ns to 1.6s (Resolution of 50 ns)

3 DLY SWP TIME

Set the the window to a desirable position by using ten keys + unit keys,

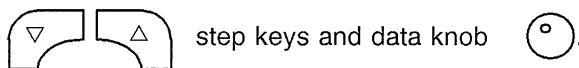

step keys and data knob.

The window is displayed when DELAY SWEEP is set to OFF. Even if the window is outside the screen, the internal data is set.

- DELAY SWEEP TIME:
- Only the right side line moves.
 - Resolution is common to the sweep time.
 - Its setting range extends from 50 μ sec to 1000sec. (Default value: 50 μ sec)
In the range between 50msec and .10sec, the SWP can be input with 1msec resolution. After the SWP input, an approximate value is calculated and set. (The setting resolution is approximately 2msec to 3msec.)

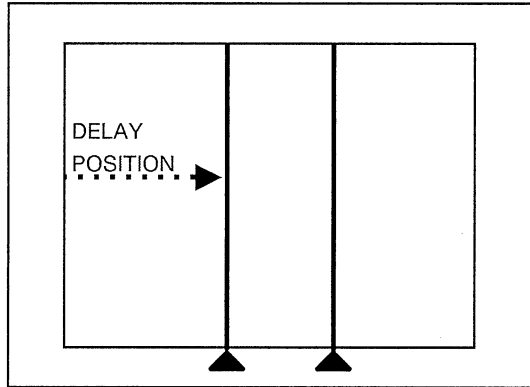

Figure 7-23 DELAY POSITION

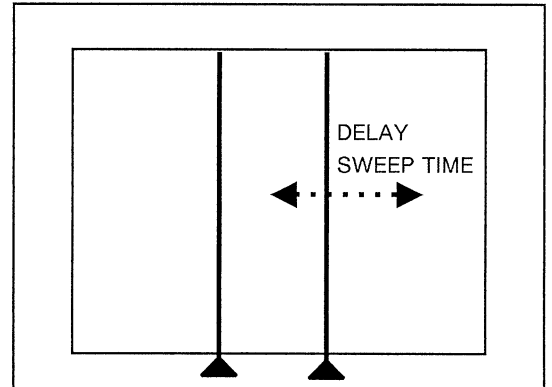

Figure 7-24 DELAY SWEEP TIME

4 DLY SWP
ON/OFF

Turns on and off the DELAY SWEEP mode.

ON: Dismiss the window and executes the delay sweep. Refer to Figure 7-26.

The delay sweep time of the window is set as the sweep time.

OFF: Releases the delay sweep and resets the sweep time to the former value. Refer to Figure 7-25.

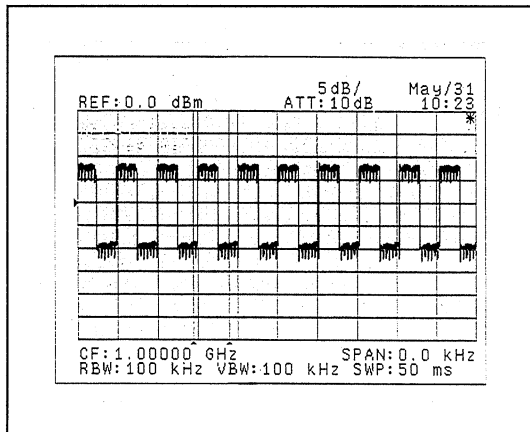

Figure 7-25 Setup mode
(DELAY SWEEP OFF)

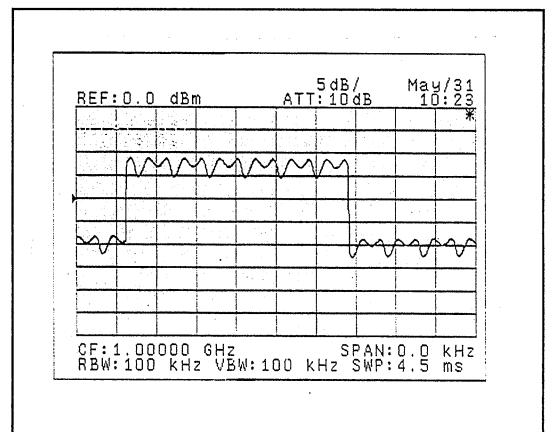

Figure 7-26 Measurement mode
(DELAY SWEEP ON)

5 SWEEP
TIME

Sets a sweep time.

6 DELAY
OFF

Escapes from the DELAY mode.

Turns off the DELAY SWEEP mode if the DELAY SWEEP mode is set to ON.

Dismisses the window if the window is displayed.

Note: This key must be pushed when the measurement is ended.

CAUTION

1. If the trigger is set to FREE RUN, the DELAY mode is released.
2. If the frequency span is set except zero, the DELAY mode is released.

(4) Gated sweep function

This function allows this unit to create an arbitrary gated signal from the trigger signal source (gate input) and allows to execute GATED SWEEP.

The measurement method is shown in Figure 7-27

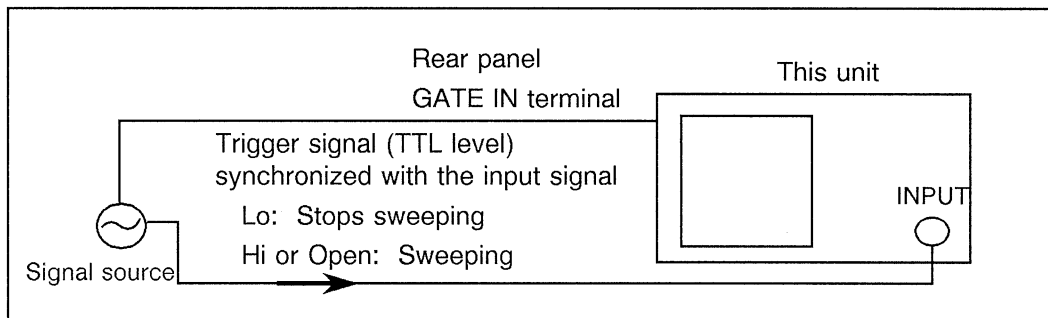
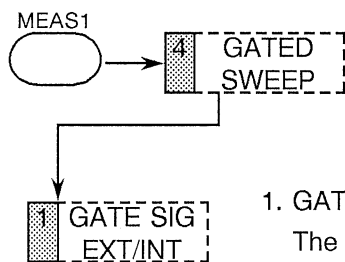

Figure 7-27 Measurement method



Pressing this key, this unit goes into the GATED mode. The setting can be switched with GATE SIG EXT/INT.

1. GATE SIG EXT

The signal input from the input connector of GATE IN controls the sweep signal directly.

The gate window is deleted and the mode to set the gate position and the gate width is ended. The data of the span, RBW, and the sweep time are reset to the value that before the GATE SIG INT was set.

2. GATE SIG INT

Sets the zero span mode and displays the gate window. (But, the gate window is not displayed at GATED SWP ON.) Refer to Figure 7-28.

The timing generation circuit inside this unit is used and the gate position and the gate width can be set.

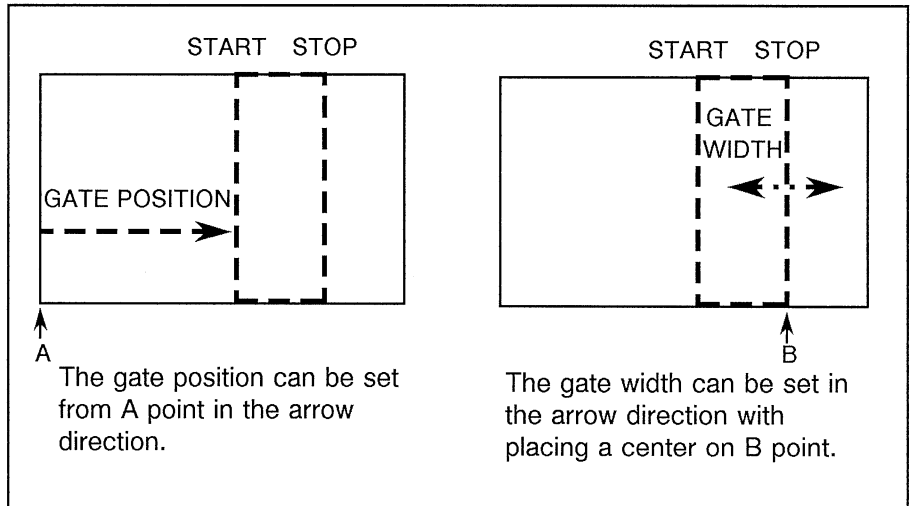

Figure 7-28 GATE WINDOW

2 GATE POSITION

The timing generation circuit inside this unit is used and the gate position can be set.

To set the data, use a numeric keypad + a unit key, step keys or a knob. The gate position is varied with holding gate width fixed.

If the gate position is set out of the gate window, the internal data is set.

Available range: 200 ns to 13 ms (200 ns steps, default value: 200 ns)

Note: When GATE SIG EXT has been selected, it is switched to GATE SIG INT.

3 GATE WIDTH

The timing generation circuit inside this unit is used and the gate width can be set.

To set the data, use a numeric keypad + a unit key, step keys or a knob. The gate width is varied with holding gate position fixed.

If the gate width is set out of the gate window, the internal data is set.

Available range: 1 μ s to 13 ms (200 ns steps, default value: 1 μ s)

Note: When GATE SIG EXT has been selected, it is switched to GATE SIG INT.

4 T-DOMAIN SWEEP

In the time-domain measurement, the sweep time can be set.

5 GTD SWP
ON/OFF

1. ON

Switches to the GATED measurement mode and executes GATED SWEEP.

When GATE SIG INT has been selected, data of the span, RBW, and the sweep time are reset to the value that before the GATE SIG INT was set.

2. OFF

GATED SWEEP is ended. After GATED SWEEP is ended, the setting is switched according to the GATE SIG EXT/INT mode.

6 GATED
OFF

Ends the GATED mode.

When GATED SWEEP ON has been selected, it is switched to OFF.

At the end of a measurement, be sure to press this key.

(5) Peak list setting menu

The peak list function allows detecting the peak of the on-screen waveform and displaying the data as the peak list.

The list can be displayed in the order of the frequency or the level.

MEAS1 → 5 PEAK
LIST

When this key is pressed, the single sweep mode is set and the peak list is displayed. Refer to Figure 7-29.

All marker functions are set to OFF.

For functions that are turned to OFF by the peak list display, refer to Subsection 7.3.4, "Marker OFF".

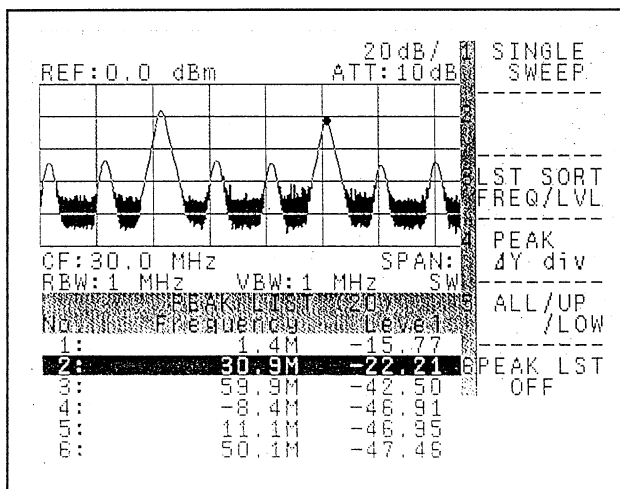
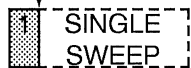

Figure 7-29 Peak List 1

- ① The peak list may be simplified when the softkey menu is being displayed. The following shows the example.
 - (a) When frequency is on the horizontal axis, the unit is simplified as follows.
 - GHz → G
 - MHz → M
 - kHz → k
 - Hz → H
 - (b) The unit of the level is displayed in the following manner. When the unit of the level is dBm, dB μ V, dB μ V_{emf}, dBmV, or dBpW, it is not displayed. Refer to the unit of the reference level. When the unit is volt or watt, it is displayed.
- ② The display of dB/div is changed as follows.
 - (a) 10dB/div → 20dB/div
 - (b) 5dB/div → 10dB/div
 - (c) 2dB/div → 4dB/div
 - (d) 1dB/div → 2dB/div
- ③ The setting range of PEAK Δ Y div is changed as follows.
 - 0.1 to 10.0 → 0.05 to 5.0



When this key is pressed, the single sweep is executed. After the sweep is completed, the number of peaks detected and the result of the sweep are displayed in a list. Then, the peak list is set to the active condition. Refer to Figure 7-30. The peak list can be moved by using the step key and the data knob.

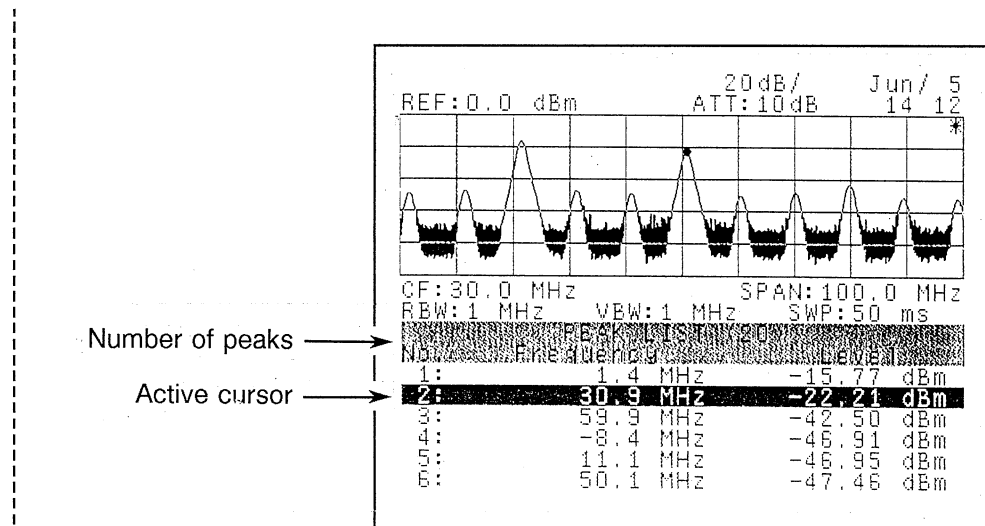

Figure 7-30 Single Sweep

Note: When you set other data entry state, the active cursor disappears.
If you want to display the active cursor again, execute the single sweep or press the PEAK LIST key.

3 LIST SORT
FREQ/LVL

This key is used to select that data are sorted in the order of frequency or of level. (The initial setting is in the order of level.)

Note: When this setting is changed, the obtained peak list is initialized.

1. In the order of frequency

All data obtained are displayed. However, up to 99 data are available.

2. In the order of level

The number of peaks to be displayed can be set. The specified number of peaks are displayed. The number can be set by using a numeric keypad + a unit key, a step key, or a knob. Up to 99 can be specified.

4 PEAK
ΔY div

To create the peak list, enter the amplitude condition of the object waveform of the peak search. The available range of the data is from 0.05 to 5.0. Data can be entered by using the numeric keypad + unit key, step keys, or the knob. The definition of the amplitude condition is the same as of the next peak search. (Refer to item 7.3.2-(2).)

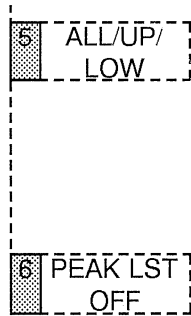

The reference level of the peak search can be changed by using the display line. When ALL is set, peak search is executed to all waveform. (Initial condition)

When UP or LOW is set, peak search is executed at the upper level or the lower level than the display line, respectively.

Pressing this key ends the peak list display.



7.4.2 MEAS2

MEAS2 makes the following six measurements possible:

1. X dB down measurement
2. Third order intermodulation distortion measurement
3. Measuring an AM modulation accuracy (%)
4. Occupied bandwidth (OBW) measurement
5. Adjacent channel leakage power (ACP) measurement
6. Power measurement

(1) X dB down measurement

The X dB down function displays the difference in frequency (and level) between a reference marker and another marker that is offset X dB down (or up) from the reference. The relative dB range that can be specified for X is from 0 to \pm screen's dynamic range is selected using

the   step keys and the data knob . The initial value is 3 dB.

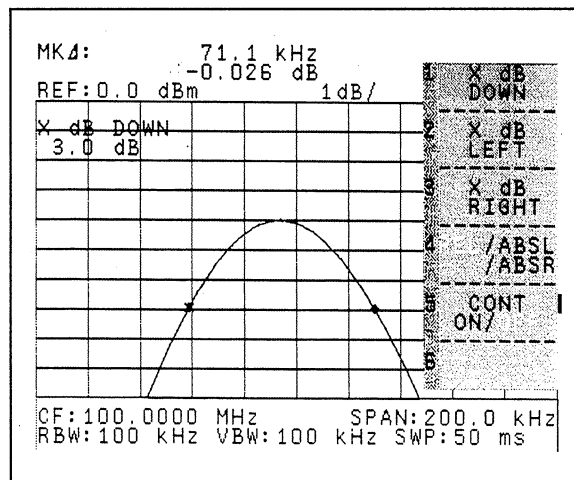
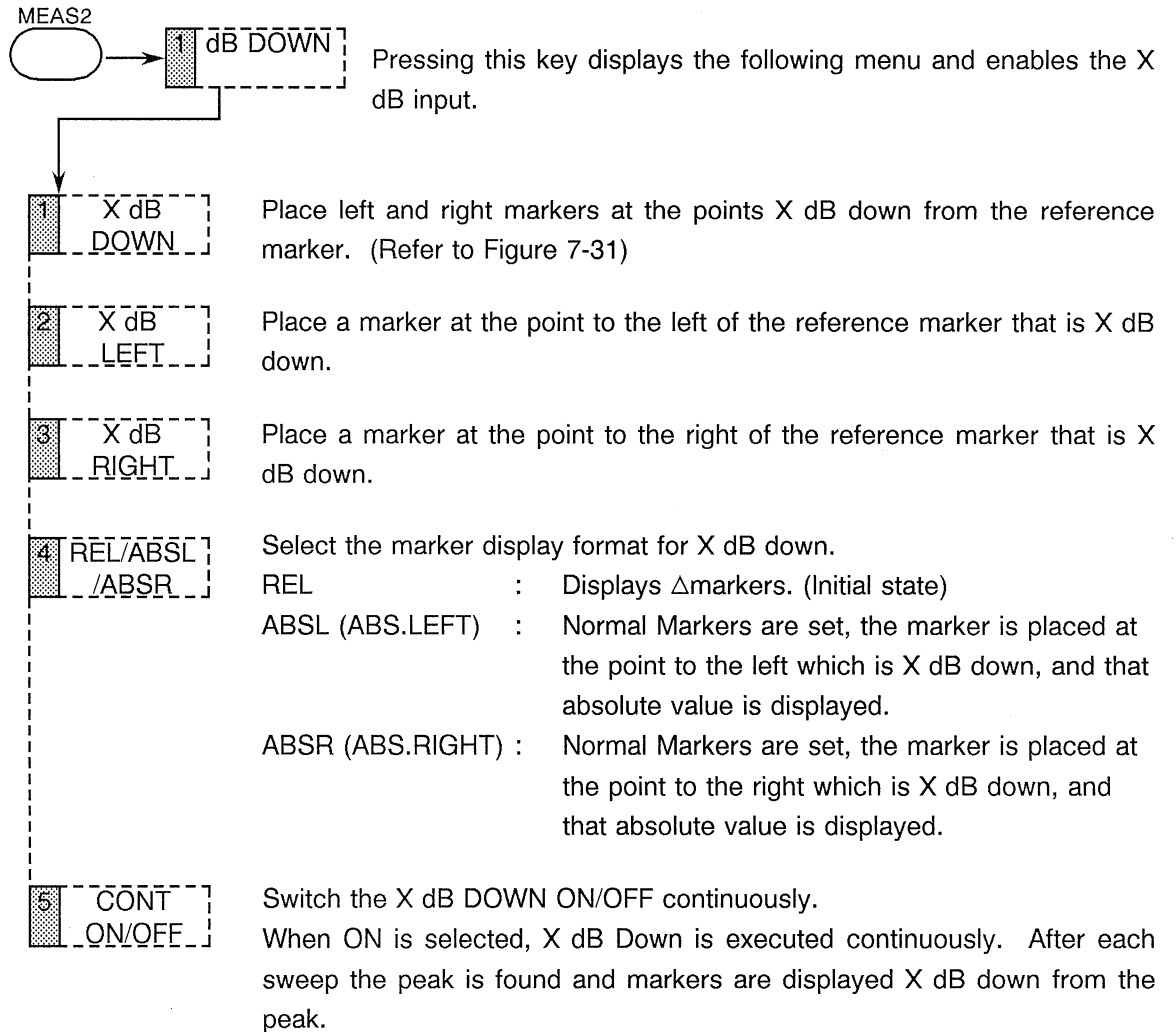

Figure 7-31 X dB down



(2) Third order intermodulation distortion measurement

Obtain the relative values (frequency and level differences) between the carrier level and the 3rd order intermodulation distortion.

For details of measurement example, refer to "6.3.2 Third Order Intermodulation Distortion Measurement".

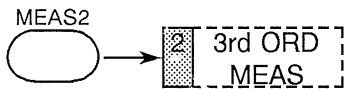

Set the Δ MARKER to the carrier level, and the active marker for third order distortion. The results as Δ MARKER value is displayed on the marker area. If the active marker is not displayed on the third order distortion position, press the

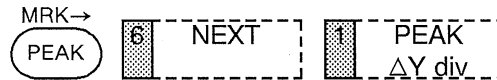

keys in that order and reset the ΔY .

For details of setting method, refer to "7.3.2 Peak Search".

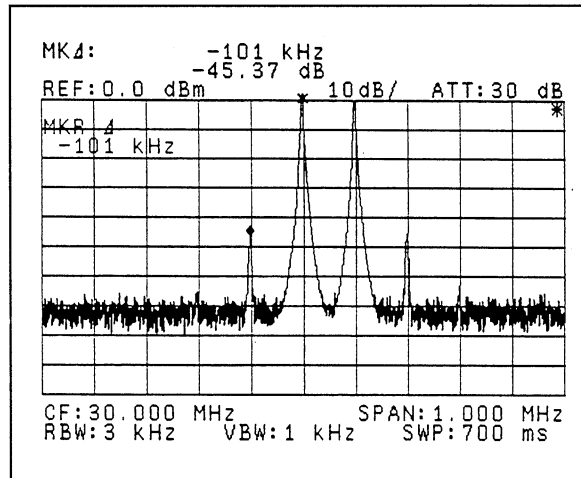
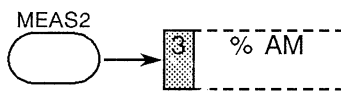

Figure 7-32 Third order intermodulation distortion measurement

(3) Measuring an AM modulation accuracy (%)

The analyzer obtains an AM modulation accuracy using the peak search function in the current setup condition, and enables to display the calculated result on the marker area with % unit.

For details of AM modulation accuracy setup, refer to "6.4.1 AM Signal Analysis".



The following three conditions are used to measure the AM modulation accuracy, and are displayed on the marker area.

- ① When putting the horizontal axis into Log scale, and the vertical axis into frequency domain (Measuring the AM modulation accuracy in high modulation frequency and low modulation accuracy)

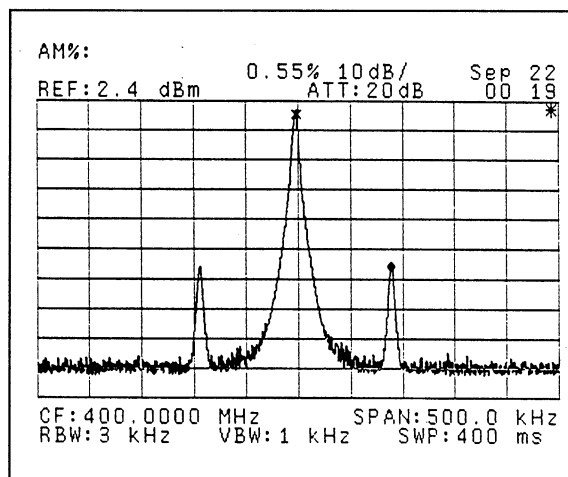

Figure 7-33 AM modulation wave spectrum
(Log scale)

ΔMarker is set as shown in Figure 7-33, and the AM modulation accuracy can be obtained by moving the Δmarker in the wave peak level, and the active marker in the next peak level.

The obtained AM modulation accuracy is displayed on the marker area with % unit.

**SPECTRUM ANALYZER
OPERATION MANUAL**

7.4 Measurement (MEAS) Function

- ② When putting the horizontal axis into the Log scale, and the vertical axis into the frequency domain (Measuring the AM modulation accuracy in high modulation frequency and low modulation accuracy).

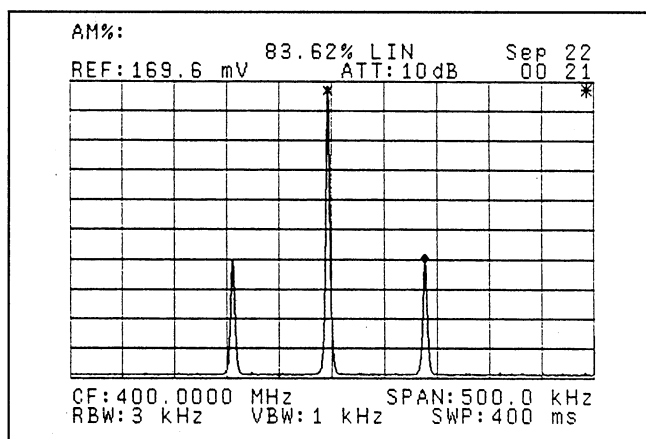

Figure 7-34 AM modulation wave spectrum (Linear scale)

Obtain the AM modulation accuracy same as the procedure ①, and display it with % unit on the marker area.

- ③ When putting the horizontal axis into linear scale, and the vertical axis into time domain

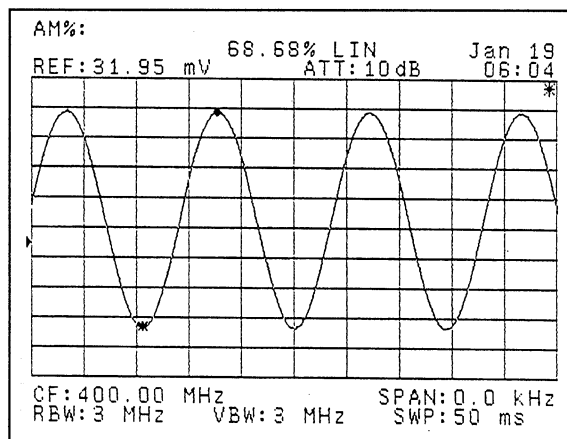
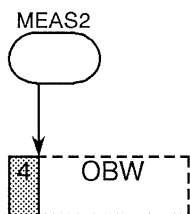

Figure 7-35 AM modulation accuracy measurement in time domain

ΔMarker is set as shown in Figure 7-35, and the AM modulation accuracy can be obtained by moving the Δmarker in the modulation wave peak level, and the active marker in the small level.

The obtained AM modulation accuracy is displayed on the marker area with % unit.

(4) Occupied bandwidth (OBW) measurement



Finds the occupied bandwidth of the signal being displayed on the screen. The results are shown in the marker display area for the occupied bandwidth (OBW) and the occupied band carrier frequency (Fc), the band center frequency. See "6.5 Occupied Bandwidth (OBW) Measurement" for the measurement method.

(5) Adjacent channel leakage power (ACP) measurement

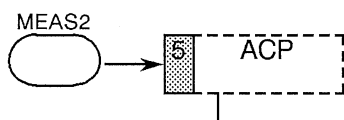

Bring up the adjacent channel leakage power measurement menu. See "6.6 Adjacent Channel Leakage Power (ACP) Measurement" for the measurement method.

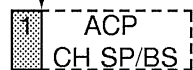

Setup the Channel Spacing (CH SP) and Bandwidth Specified (BS) for the ADJ measurement. At each push the CH SP and BS selection toggle, the one selected is shown in reverse video. Input the frequency using the numeric key and units keys.

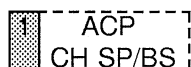

Measure the leakage power in the channels adjoining the center channel.

Channel spacing from the center is set with .

The results are displayed in the marker display area, labeled with UP and LOW for the Upper and Lower channel respectively. A marker appears at each adjacent channel frequency.

CAUTION

1. Measurement error will be made if an active marker is not set to the center channel frequency before making the ACP measurement.
2. If the ACP SETUP channel width and spacing are not specified, or if the values are incompatible or inconsistent, then the ACP POINT function will not work.

3 GRAPH
ON/OFF

When ON is selected, the leakage power across the entire displayed spectrum is calculated and shown as a graph. The channels used are

those defined with the 1 ACP
CH SP/BS menu (above) for the bandwidth

specified. The marker is positioned on the graph, and the associated leakage power is displayed. Move the marker to see the leakage power at different channels.

When OFF is selected, the graph is erased.

CAUTION

The ACP GRAPH function cannot be operated when the measurement bandwidth is not specified.

4 MKR →CF

Set the Center Frequency to be the current marker frequency. Handy for getting the carrier frequency to the measurement reference frequency (i.e., the center of the display).

5 MARKER
MOVE

Enable to move the marker with ACP softmenu being displayed. Pressing this key displays the frequency in the active marker area, and sets the marker point using the numeric key and units keys, the

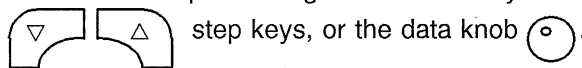

(6) Power Measurement

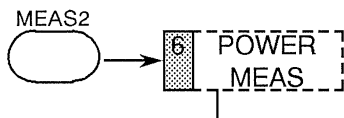

Selects the power measurement.

The power measurement is used to calculate the power from the on-screen signal. The power measurement of a wide-band modulated wave can be carried out. Correction of RBW is also executed. So, execute PBW in the CAL menu item.

1 CHANNEL
POWER

Measures the power in the specified band in the window.

(Executes operations of the window span and RBW from the average power value in the window and calculates the sum total.)

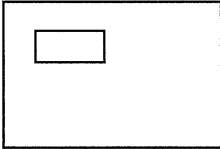
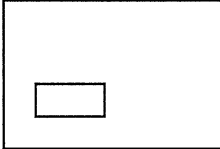
2 TOTAL POWER	Measures the sum total of the power in the entire measurement span. (Executes operations of the measurement span and RBW from the average power value and calculates the sum total.)
3 AVERAGE POWER	Measures the average power in the entire measurement span. (Converts the data (dBm) of all points displayed into the antilogarithm of the power dimension and calculates the average.)
4 CARRIER POWER	Measures the peak power. (Moves the marker to the peak and calculates the power.)
5 DSP POS1 UP/LOW	Selects the position of displaying the measurement result.  UP  LOW
6 RETURN	Returns to the previous menu.

7.5 User-Defined Functions

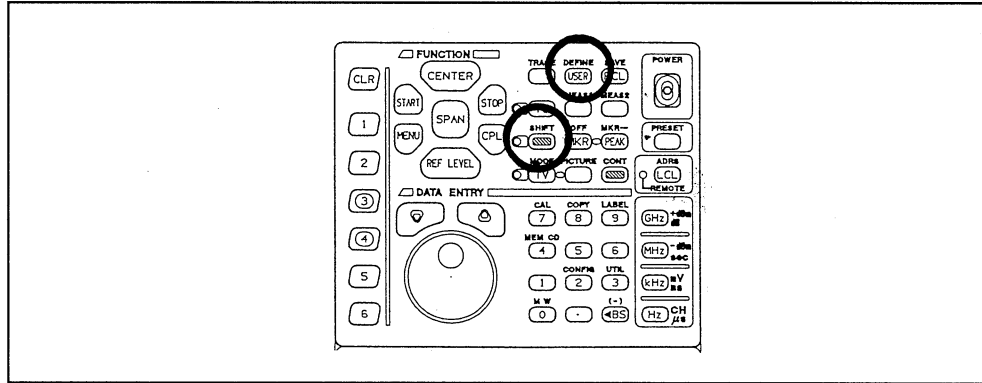



Figure 7-36 Location of the user-defined key on the front panel

This function allows the user to modify the functions (menu items) that appear on any of the softkey menus, or to define the User softkey menu. The number of key pushes to achieve frequent tasks can be greatly reduced by moving menu selections to higher priority locations, or by assigning them to one of the user-defined softkeys.

Press   and the screen show in Figure 7-37 will appear.

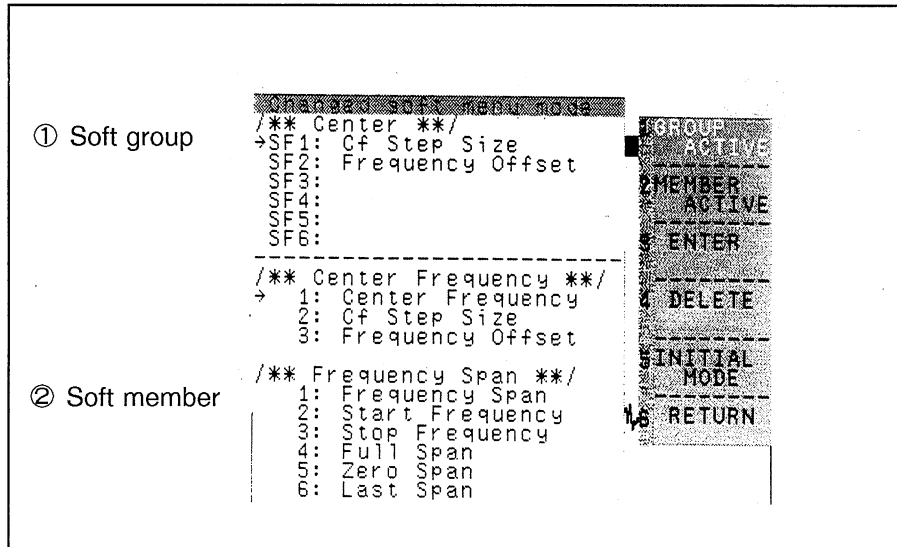

Figure 7-37 User-defined display

① Soft group

The top half of the screen displays the current softkey menu assignments for the function keys (SF1 to SF6).

② Soft member

The bottom half of the screen presents the member functions from the softkey menus that can be reassigned.

(1) Menu explanation

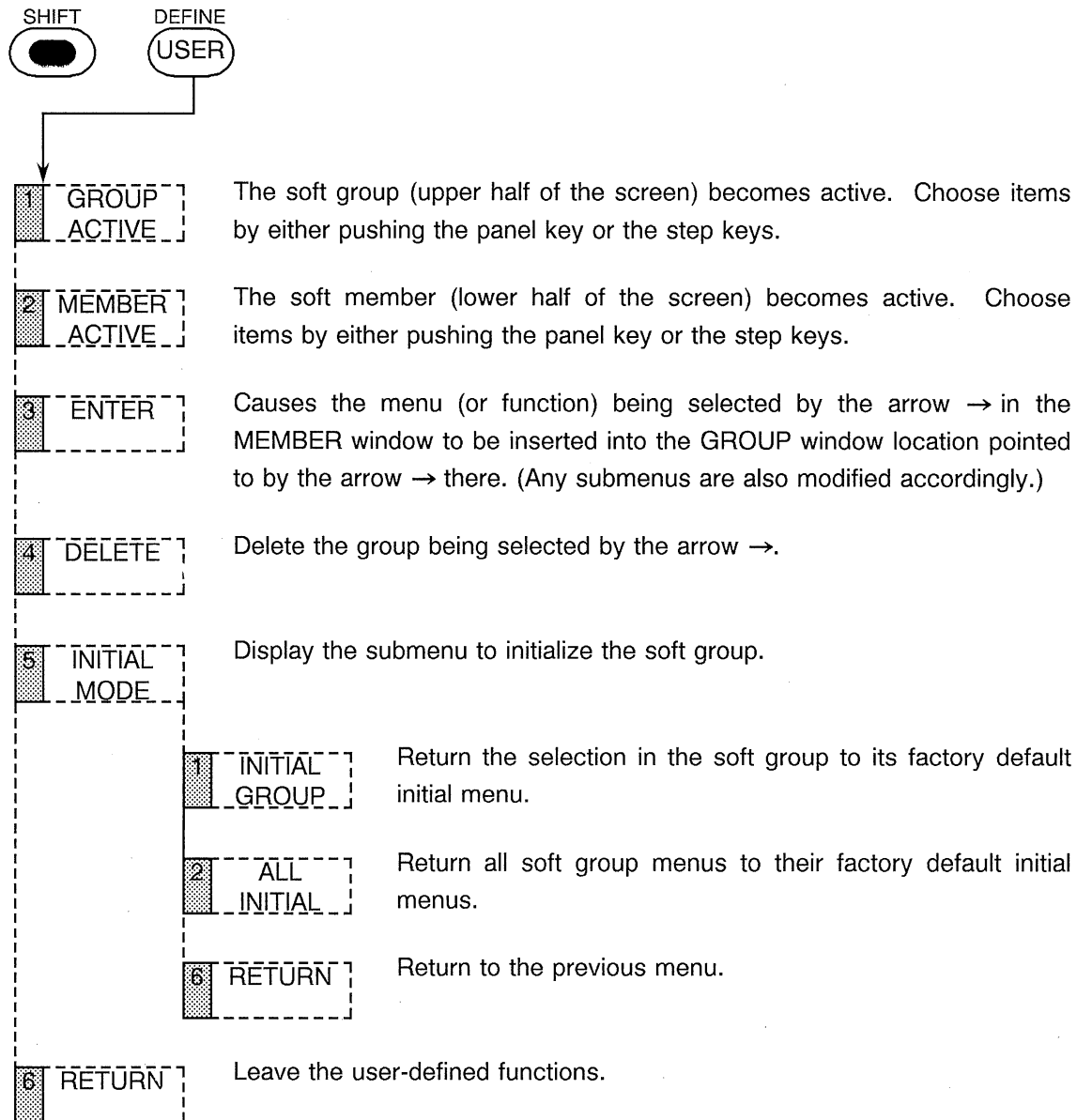

(2) Example of setting up a user-defined key

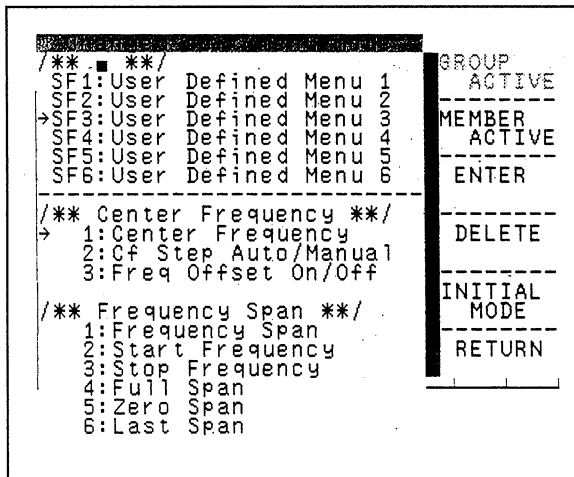

① Press and then and then

use the panel keys or the step keys to select the soft group that you want to modify. In this case, push "USER" and the display to the left will appear.

② Select the soft key for which the assignment will be made by moving the arrow → at the left side of the display with the data knob . In the example to the left, SF3 has been selected.

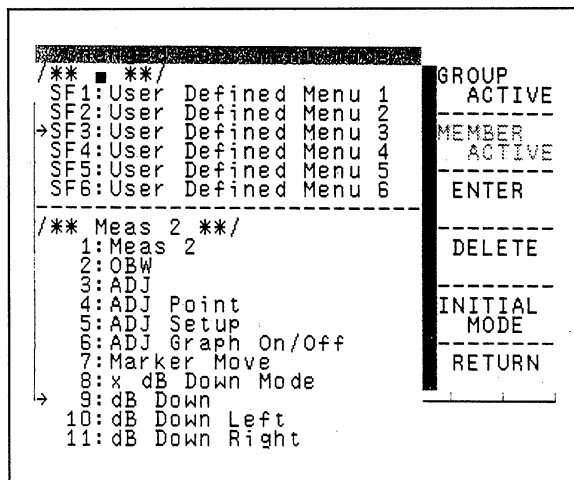

③ Next we will chose something from the member window to be assigned to the key chosen in step ②.

Press to make the lower window

active, and make a selection either with a panel key push, or by moving the arrow → up and down with the step keys or the data knob

. Here we choose "dB DOWN" from the soft menu (MEAS2).

```

** ■ **/
SF1:User Defined Menu 1
SF2:User Defined Menu 2
→SF3:dB Down
SF4:User Defined Menu 4
SF5:User Defined Menu 5
SF6:User Defined Menu 6

/** Meas 2 **/
1:Meas 2
2:OBW
3:ADJ
4:ADJ Point
5:ADJ Setup
6:ADJ Graph On/Off
7:Marker Move
8:x dB Down Mode
→9:dB Down
10:dB Down Left
11:dB Down Right
  
```

GROUP
ACTIVE

MEMBER
ACTIVE

ENTER

DELETE

INITIAL
MODE

RETURN

④ Press 3 ENTER to execute the soft group

modification or addition. To the left we see that "dB DOWN" has been assigned to SF3 in the USER key.

As long as assignment is not changed (initialized),

then press DEFINE
USER 3 USER3 will

execute the dB DOWN function. The soft group

reset to the default menu, press 5 INITIAL
MODE.

Note: If a Member name has "****" in front of it, then that item cannot be modified or have additions made to it.

7.6 Save/Recall Functions of Memory Card

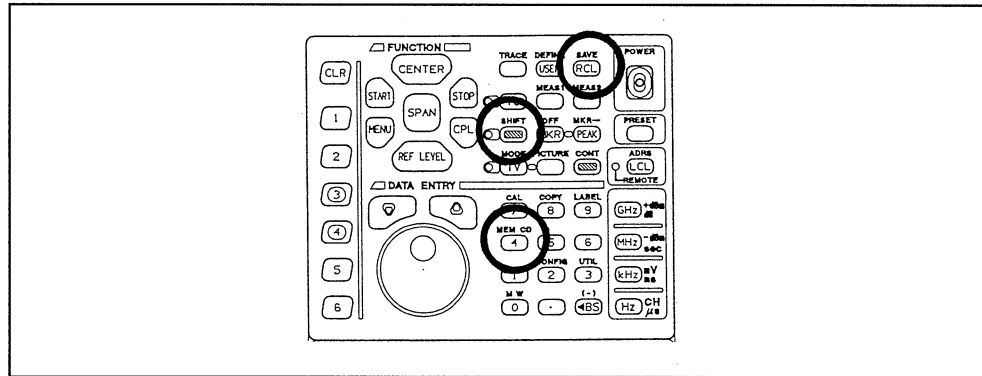

Figure 7-38 Save/Recall function keys of the memory card on the front panel

Using the memory card, the current analyzer setup parameters and spectrum data can be saved, or a previously saved set can be read back into the analyzer to restore its condition to the point at which the save was made.

The file list shown in Figure 7-39 is displayed whenever any of the following key combinations is pressed:

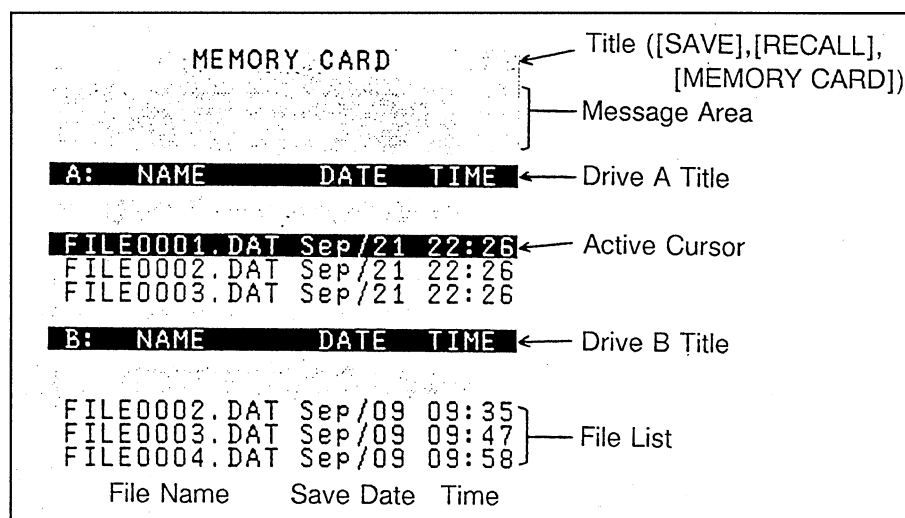
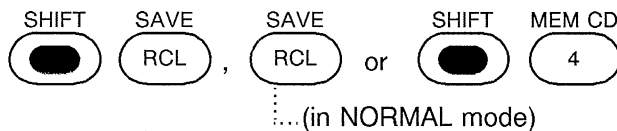

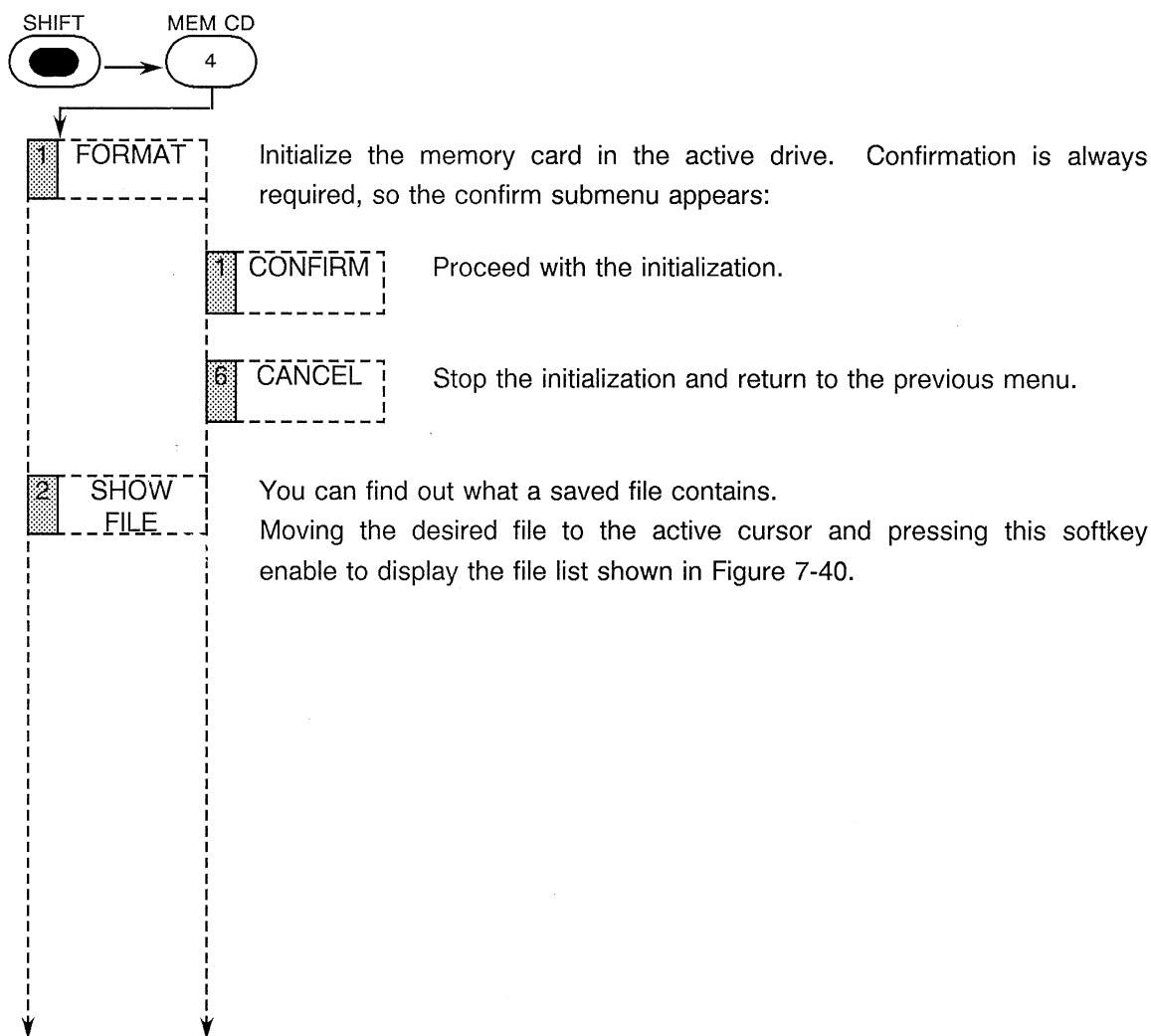

Figure 7-39 File list display

- The top window is for drive A, which is the memory card closest to the front of the analyzer. The bottom window is for the other memory card, drive B.
- The active drive is toggled with .
- File selection is made by moving the cursor to the desired file with the step keys and the data knob .

7.6.1 Memory Card Functions

This function provides the memory card initialization and the copy function using two memory cards.



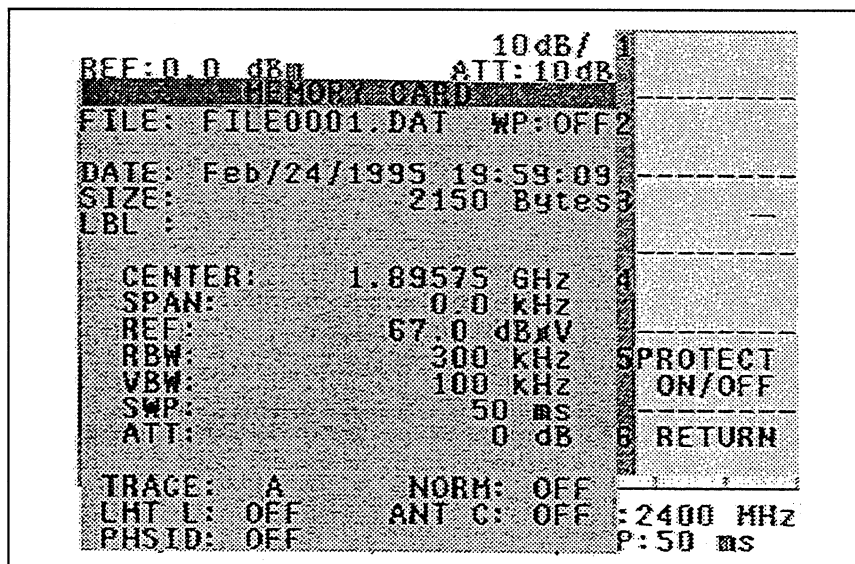

Figure 7-40 Saved file contents display with SHOW FILE function

[Description of file contents display]

FILE : Indicates a file name.

WP : Indicates a WRITE-PROTECTION state.
ON ... Indicates a WRITE-PROTECTION (read only) state.
OFF ... Indicates a WRITE-ENABLED state.

LBL : Displays the label from the first to the 23th character.

TRACE: OFF ... Waveform data cannot be stored.
A ... Waveform data A can be stored.
B ... Waveform data B can be stored.
A,B ... Waveform data A and B can be stored.

LMT L : OFF ... Limit line cannot be stored.
1 ... Limit line 1 can be stored.
2 ... Limit line 2 can be stored.
1,2 ... Limit lines 1 and 2 can be stored.

NORM : OFF ... Normalized data cannot be stored.
ON ... Normalized data can be stored.

ANT C : OFF ... Compensation table cannot be stored.
ON ... Compensation table can be stored.

PHSID OFF ... ID-list cannot be stored.
ON ... ID-list can be stored.

5 PROTECT ON/OFF Apply WRITE-PROTECT to the selected file.
Select ON to WRITE-PROTECT state, OFF to cancel WRITE-PROTECT state.

6 RETURN Return to the previous menu.

3 COPY A→B
or
3 COPY B→A

Copy the file selected with the cursor arrow to the other memory card. At that time, moving the active cursor switches the display 'A→B' and 'B→A' in the copy menu.

Moving the active cursor to the desired file and pressing this softkey enable to display the following softkeys.

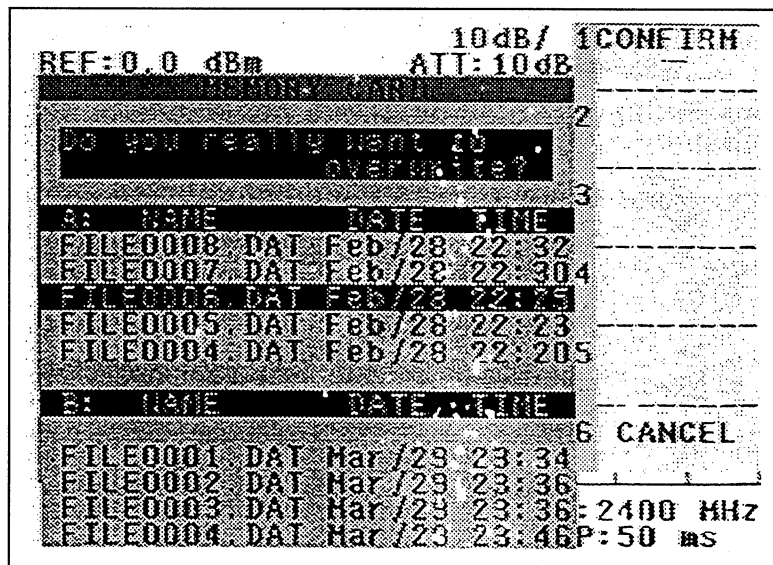

When a memory card to copy has a file with a same name, the following softkeys are displayed with a message confirming the overwriting.

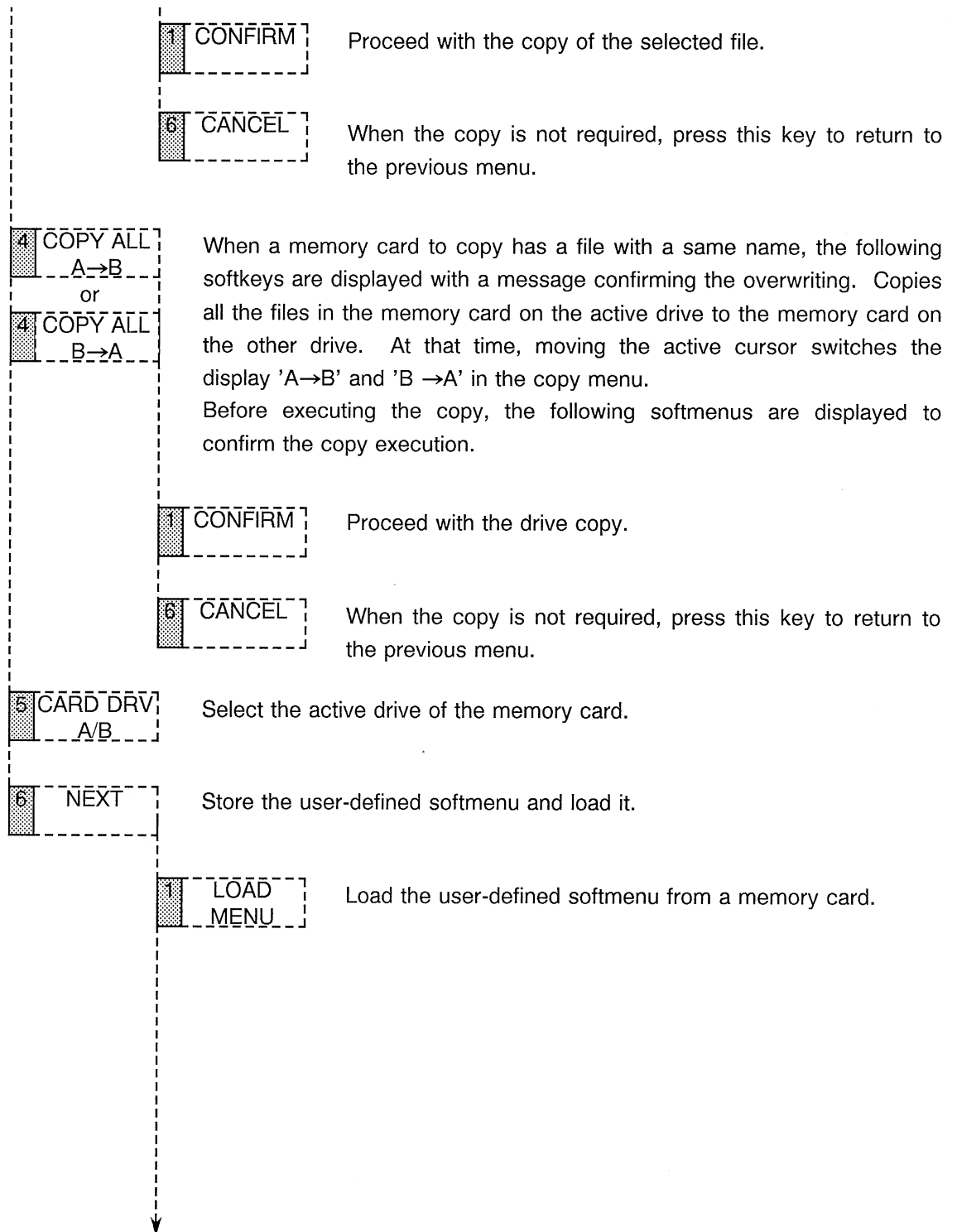

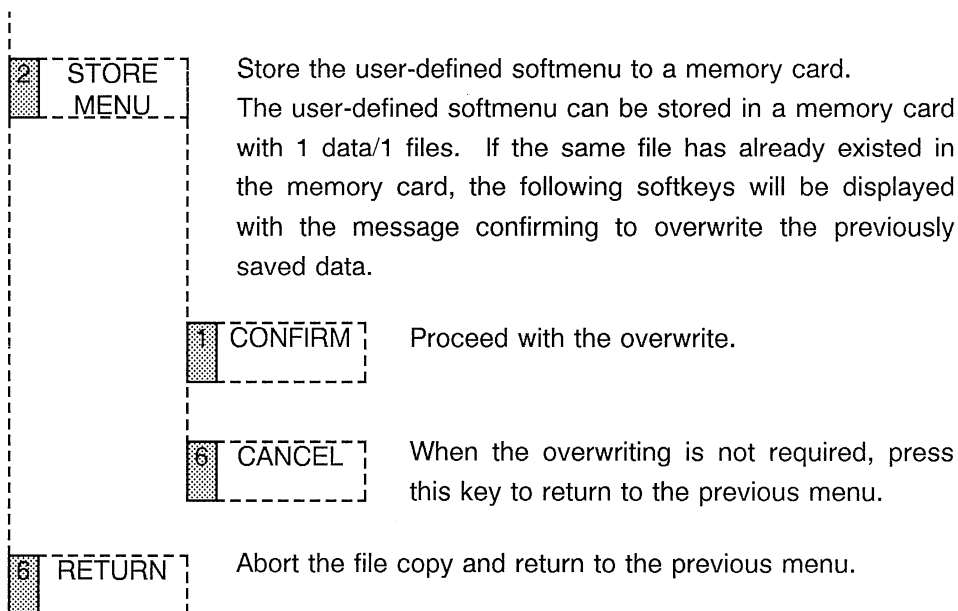

CAUTION

1. Save and Recall functions will not operate without a memory card.
2. Memory cards that can be used in the analyzer are those that conform to the Japan Electronic Industry Development Association (JEIDA) Specification Version and PCMCIA Release 2.0.
See "5.4 Memory Card Use" for information about memory card care and use.
3. COPY ALL function cannot operate using 2 memory cards which have each different memory capacity.

7.6.2 Save Function

This function is used to save the current settings and the waveform data to the memory card inside the specified drive.

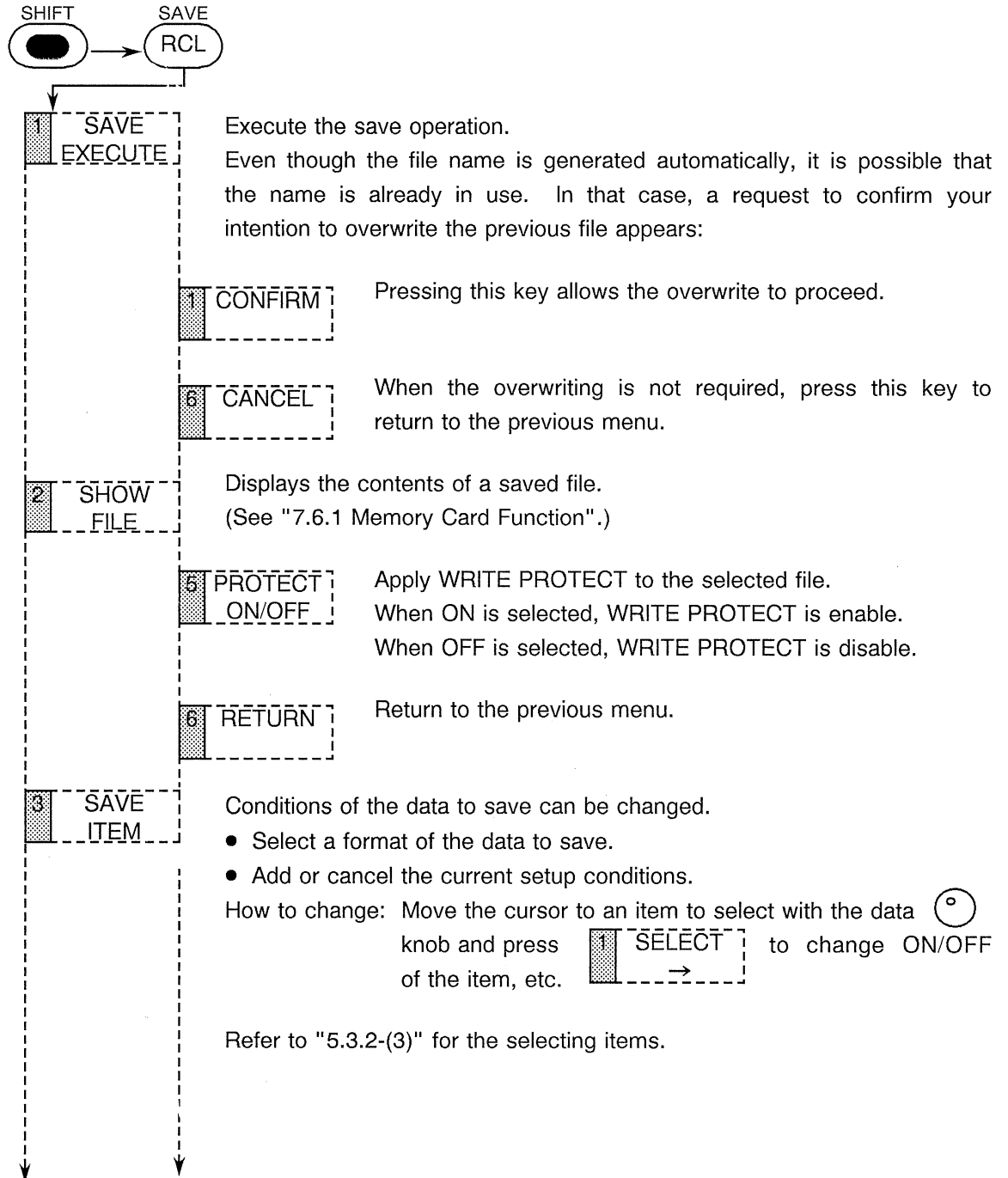

1	SELECT →	Change the ON or OFF, etc. of the item.
4	DEFAULT	Returns the saving conditions to default status.
6	RETURN	Return to the previous menu.
4	DELETE FILE	Delete the file selected by the cursor. But before the file is actually deleted, a confirmation must be made:
1	CONFIRM	Confirms and executes the deletion.
6	CANCEL	When you do not want to delete the file, press the CANCEL key. The previous menu is restored.
5	CARD DRV A/B	Select the active drive in memory card. Drive A is the one closest to the front panel of the analyzer. (Refer to Figure 5-24.)
6	rename	Change the already created file name (8 characters). For details, refer to "7.11 Label Function".
1	MARK 1/2/3	Select the desired character type among 1/2/3.
2	SPACE	Insert a space (blank) in the label.
3	LABEL CLEAR	Erase the entire label.
6	RETURN	Return to the previous menu.

7.6.3 Recall Function

Recall the data saved in the memory card, and restore the analyzer state to the condition it had when the save was made.

FAST and NORMAL modes of the recall function can be switched. In FAST mode, once the setting conditions are registered to the recall register, the setting can be recalled only by specifying the register number.

(1) In NORMAL mode

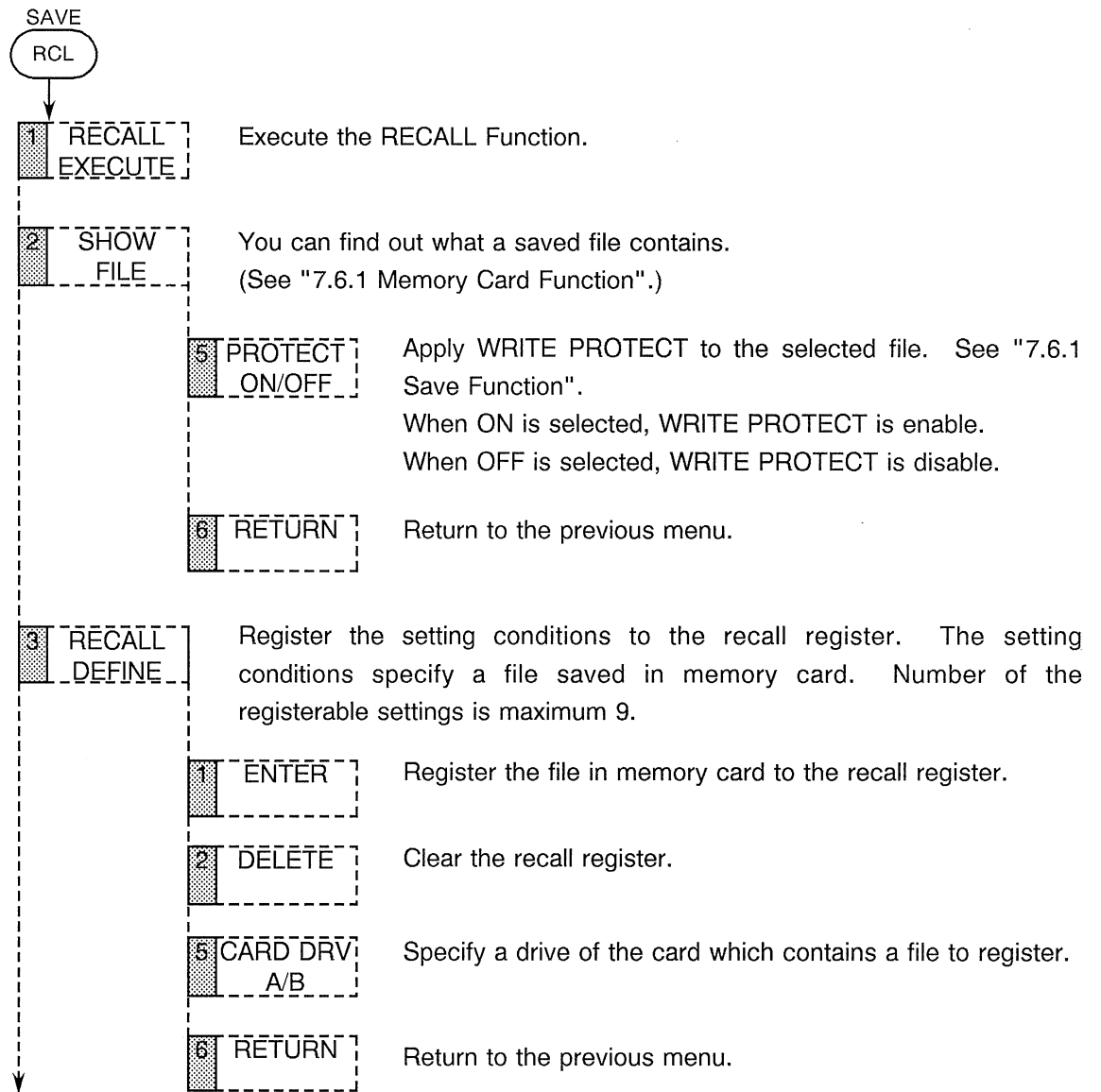



Select the active drive in memory card. Drive A is the one closest to the front panel of the analyzer.

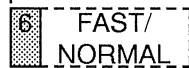

Switch the recall function.

(2) In FAST mode

① How to recall

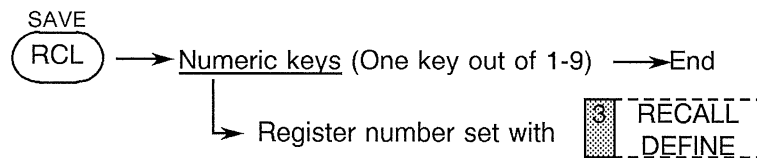

② Menu explanation



The softmenu in FAST mode is displayed.

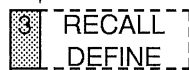

Register the setting conditions to the recall register. The setting conditions specify a file saved in memory card. Number of the registerable settings is maximum 9.



Select the active drive in memory card. Drive A is the one closest to the front panel of the analyzer.



Switch the recall function.

7.7 Preset Function

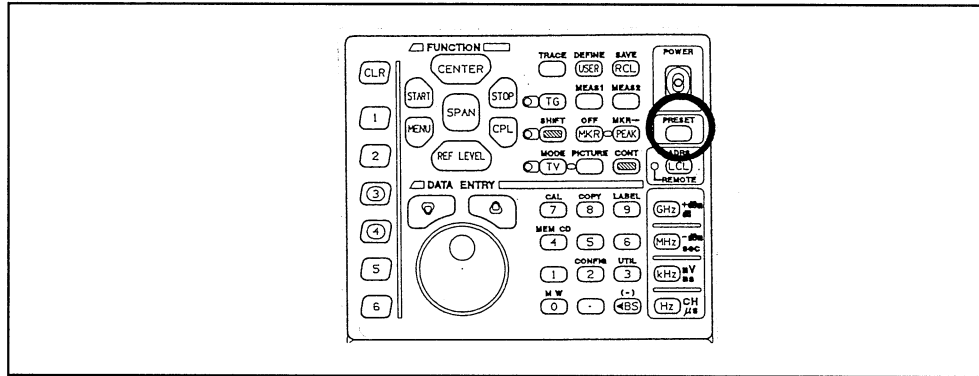

Figure 7-41 Front panel preset function key

Press  returns all of the analyzer display control parameters back to the initial values they had when shipped from the factory.

Table 7-3 Factory initial setup

Parameter setting	Initial values
Center frequency	1.6 GHz
Frequency span	3.2 GHz
Reference level	0 dBm (110 dB μ V)
Vertical scale	10 dB/DIV
Sweep time	AUTO 50 msec
Resolution bandwidth	AUTO 3 MHz
Video bandwidth	AUTO 3 MHz
Input attenuator	AUTO 10 dB
Trigger mode	FREE RUN
Trace mode	A: WRITE, B: BLANK
Marker	OFF
Display line	OFF
Label function	OFF
Internal pre-amplifier	OFF

Note: The output device (printer/plotter) parameters that had set with the CONFIG key cannot be initialized.

**SPECTRUM ANALYZER
OPERATION MANUAL**

7.8 Configuration (CONFIG) Function (Initialization Function)

7.8 Configuration (CONFIG) Function (Initialization Function)

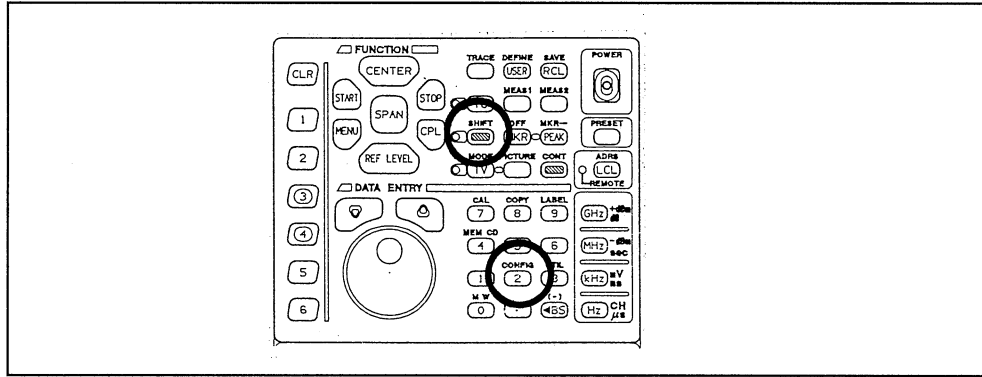



Figure 7-42 Front panel CONFIG key

This function is used to initialize the following condition.



When this condition was set once, it is not necessary to set the condition again each time this analyzer is used.

1. Printer/plotter/memory card output configuration setup
2. Date and time setup (DATE function)
3. Power OFF function setup
4. RS-232 remote control function setup
5. CPU check function setup
6. Battery check function setup
7. 10 MHz frequency reference source external/internal or internal high stab reference (option) toggle setup

All of the values set for these items are fully backed up; turning the power off and on, or using the PRESET

 to reinitialize the analyzer will not affect them at all.

If you make sure that the printer/plotter/memory card setup is done when the analyzer is first set up (or changed), then a hard copy of the display screen can be easily made any time by just

press  and .

7.8.1 Printer/Plotter/Memory card Output Setup

CAUTION

1. Please refer to "5.2 Output of Screen Data" for the printer/plotter/memory card information about the output procedure.
2. If you change the printer or plotter operating environment and do not make the corresponding changes to the analyzer configuration, then it is quite likely that the hard copy function will not work.
3. Please refer to the appropriate printer or plotter manual for information about the correct procedure of the output device itself.

(1) Printer/plotter selection

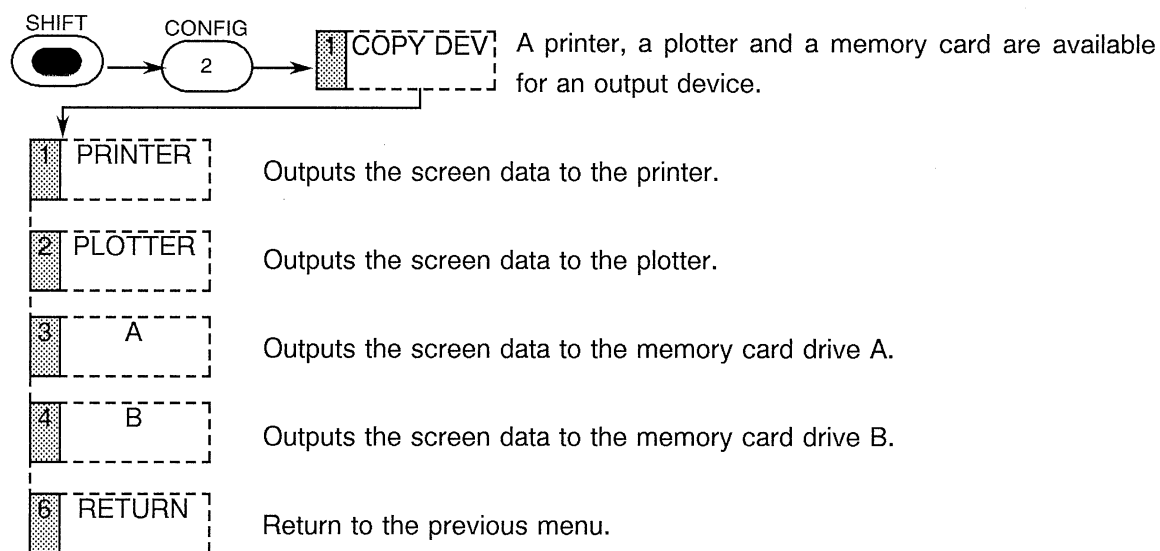

CAUTION

Please don't select printer and attach a plotter, or plotter and attach a printer. Display screen copy cannot be done if the selection here is reversed.

(2) Printer output configuration menu

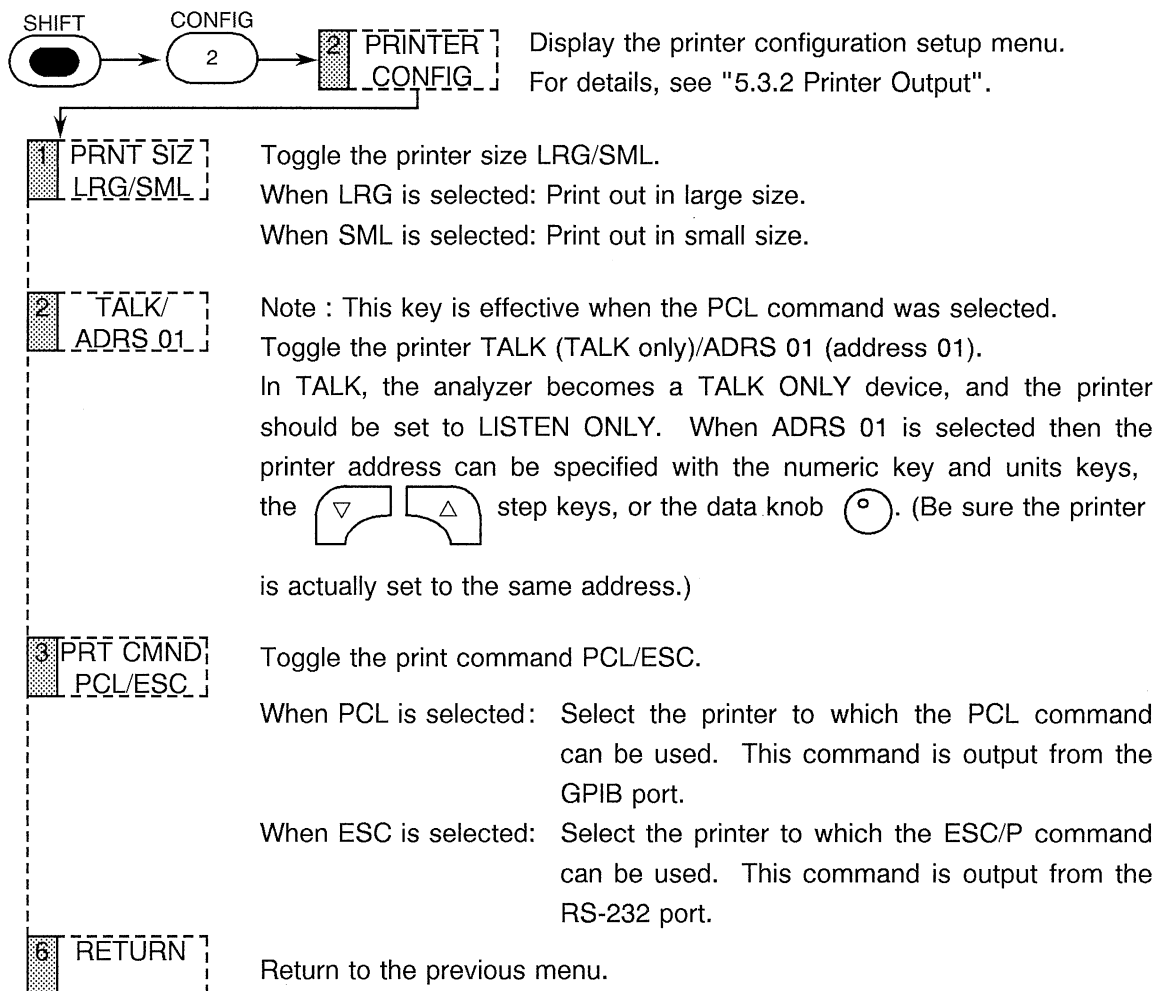

(3) Plotter output configuration menu

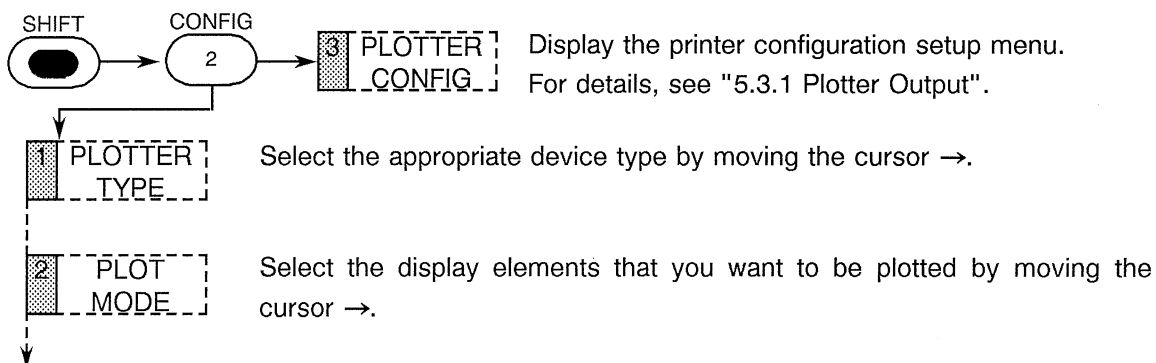

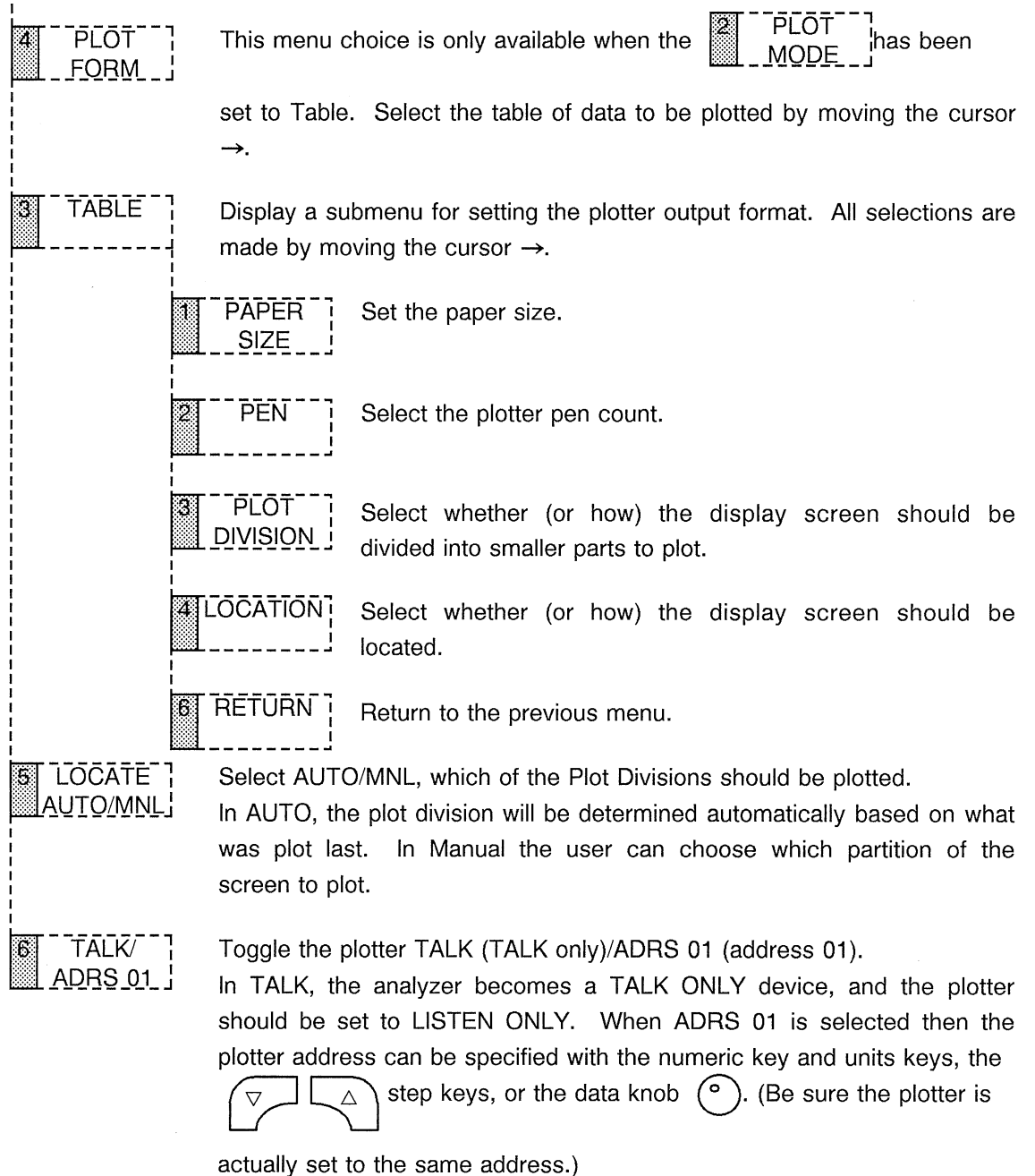

(4) Memory card output configuration menu

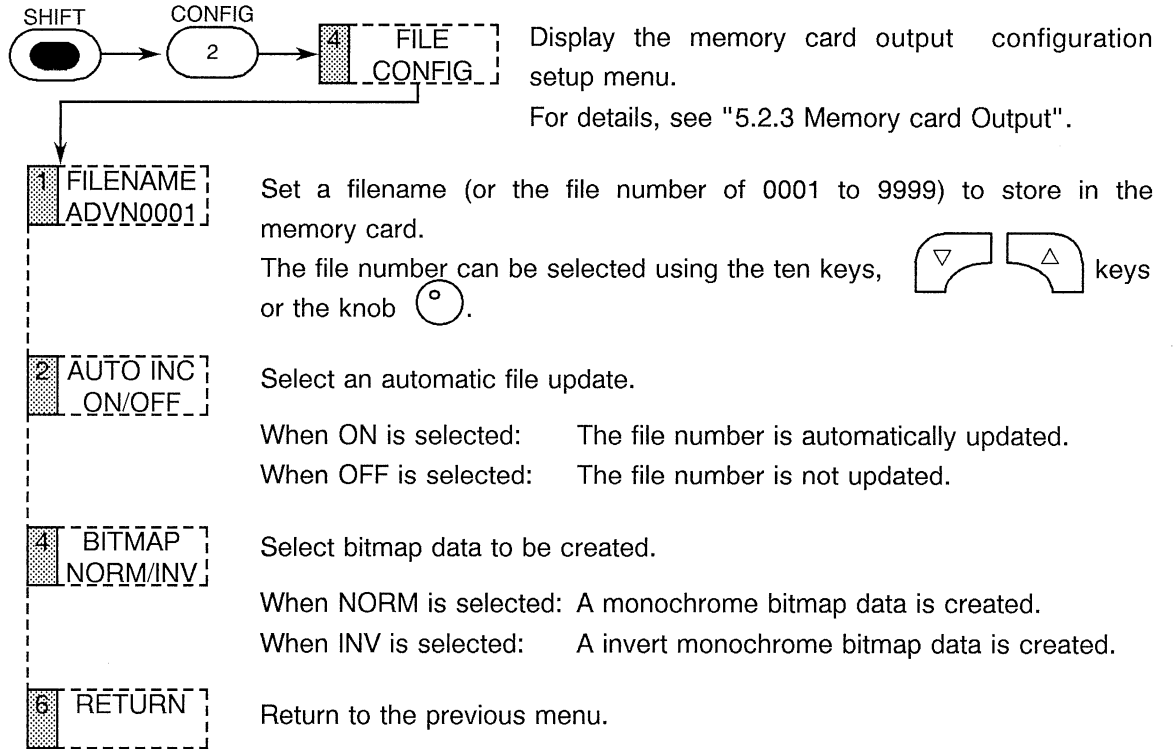

(5) Canceling the data output directed to a printer or a plotter.

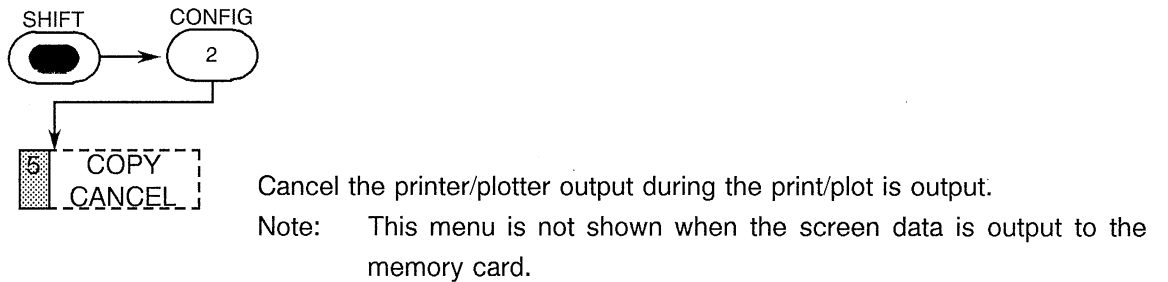

7.8.2 DATE Function

Allows setting the date and time. The date can be set between January 1, 1989 and December 31, 2088 (including Leap Year dates as well).

The corresponding day of the week will be automatically determined.

The time of day can always uses a 24 hour display.

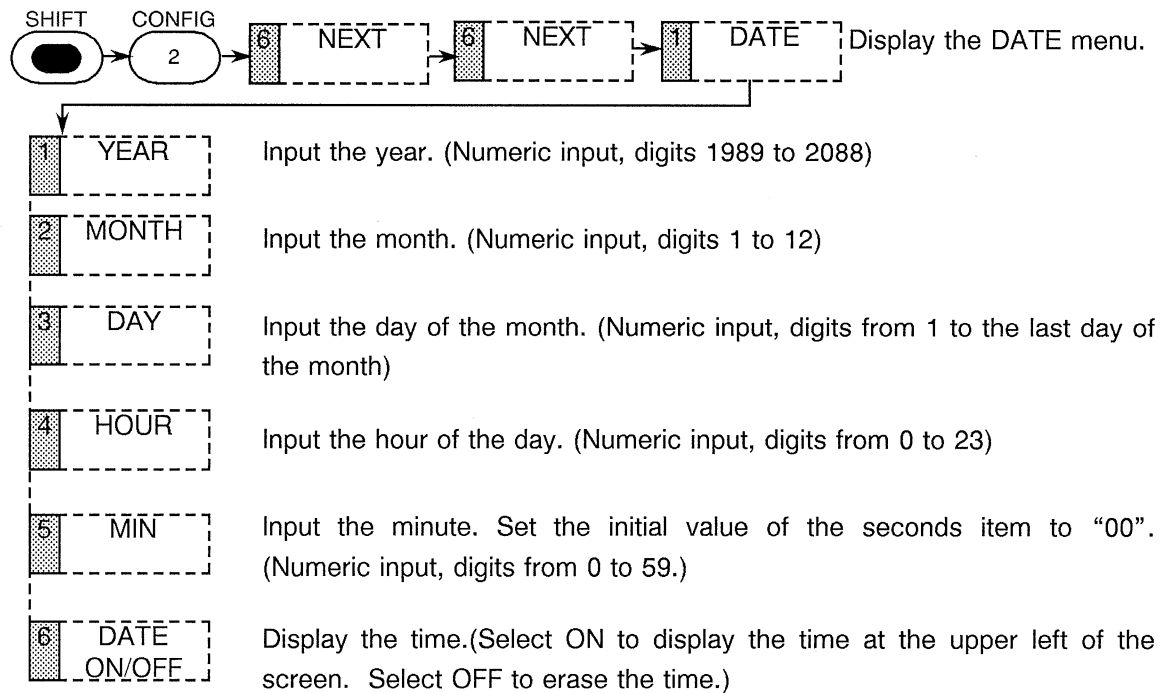

7.8.3 Power OFF Function

The analyzer makes possible the I/O port (GPIB and RS-232) hardware block power OFF to enable the continuous operation for batteries.

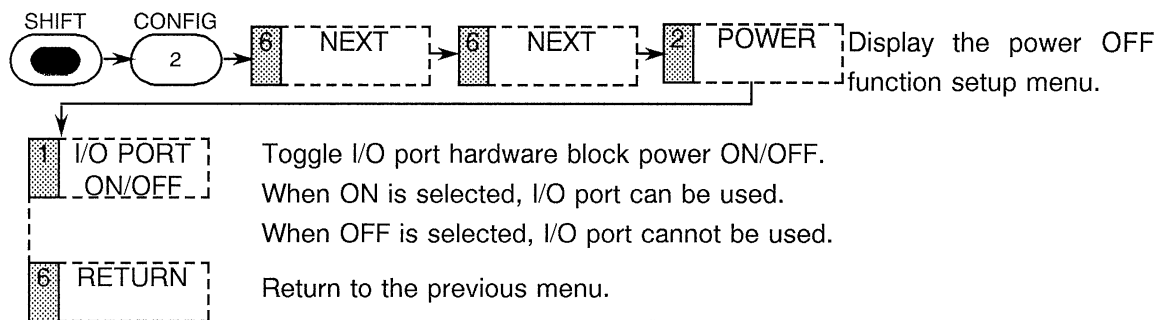

CAUTION

Using the power OFF function, the function that is set to OFF cannot be used. To use it again, set the function to ON.

7.8.4 RS-232 Interface Communication Port Setup

The analyzer can be remotely controlled (remote control function) by an RS-232 interface. See "5.5 RS-232 Remote Control Function" for more information about the connection method of the analyzer and the remote control function.

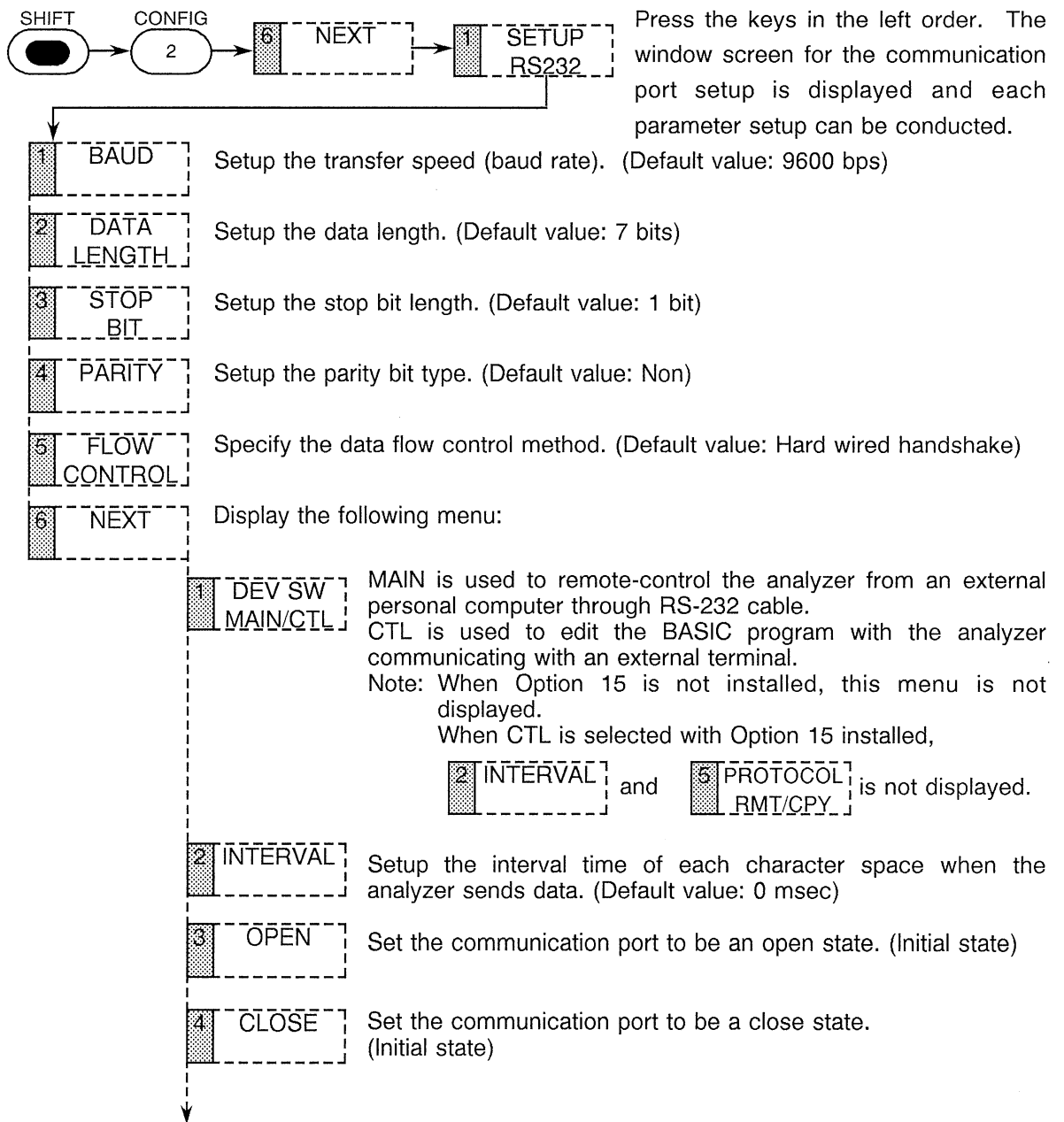

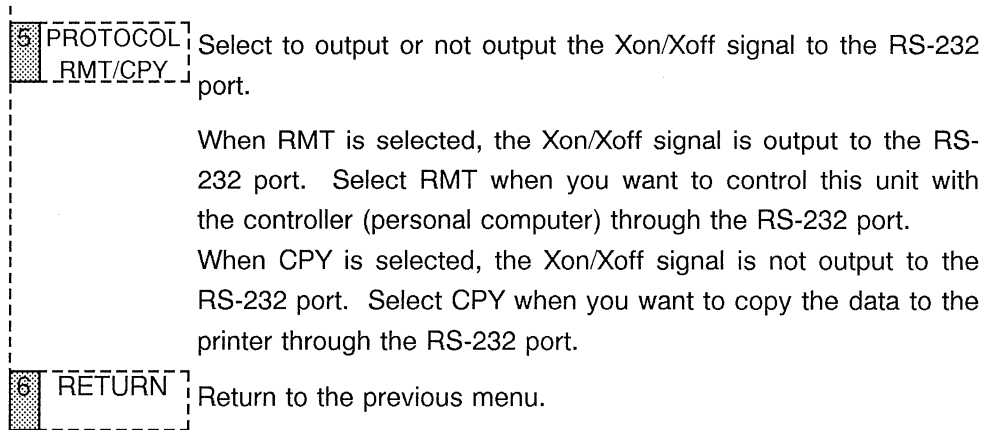

7.8.5 Switching External/Internal of 10 MHz Frequency Reference Source

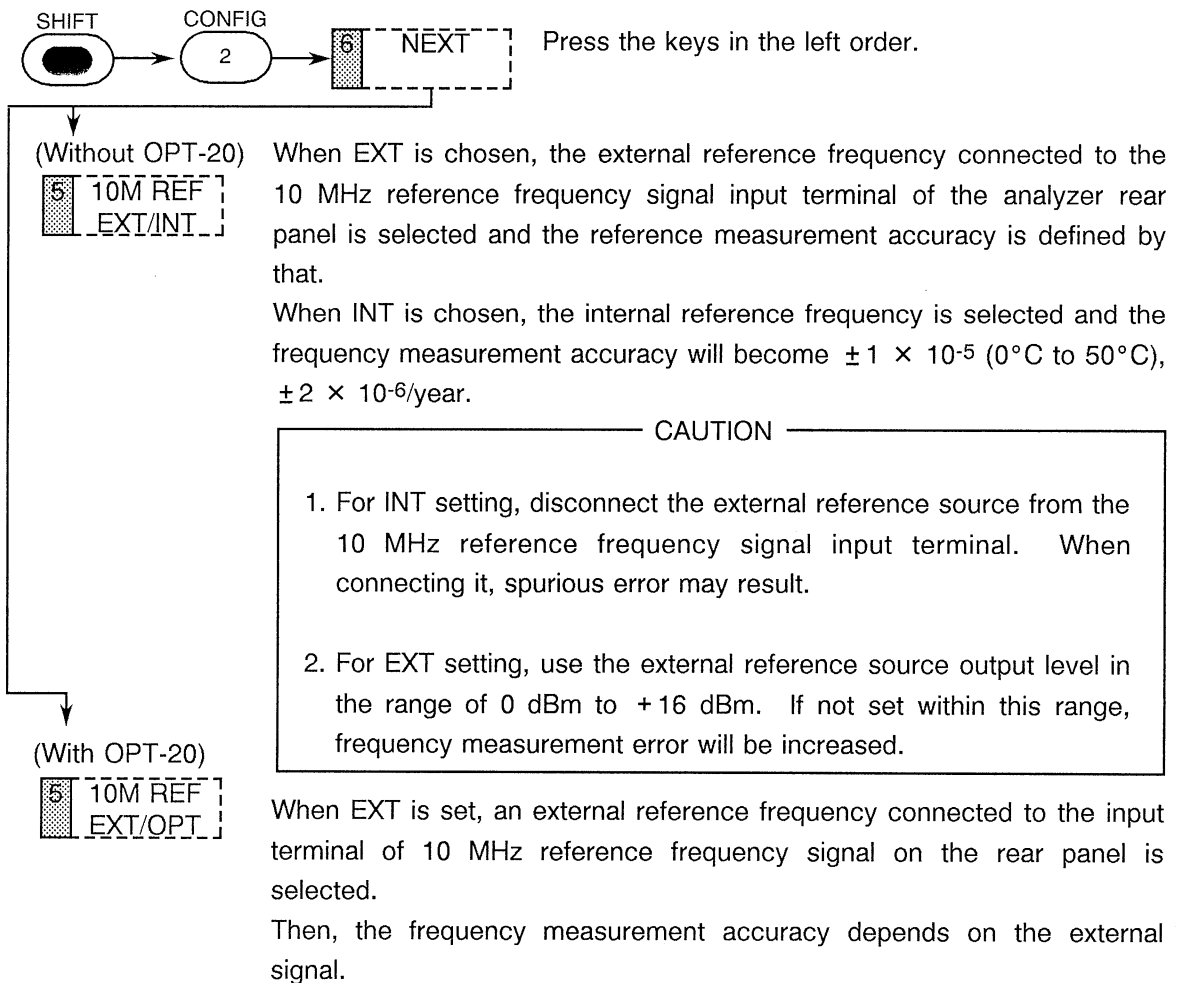

**SPECTRUM ANALYZER
OPERATION MANUAL**

7.8 Configuration (CONFIG) Function (Initialization Function)

When OPT is set, the optional reference frequency is selected, and the frequency measurement accuracy becomes $\pm 2 \times 10^{-8}$ /day, $\pm 1 \times 10^{-7}$ /year and $\pm 5 \times 10^{-7}$ (at 0 to 50°C).

CAUTION

1. When OPT is set, remove the external reference source from the input terminal of 10 MHz reference frequency signal.
The external reference source connected would cause a malfunction.
2. When the power of the spectrum analyzer is turned on to set OPT, the message "OVEN COLD" may be displayed occasionally. This symptom is phenomenon occurs while the high-stable reference oscillator is warmed up. An accurate trace cannot be displayed during this period. It may require a few minutes to warm-up this spectrum analyzer.
3. OPT-20 consumes the power through the AC adopter or the battery to maintain internal oscillation even though the POWER switch on the front panel is OFF
When using the battery, be careful of its discharge.

7.8.6 CPU check function

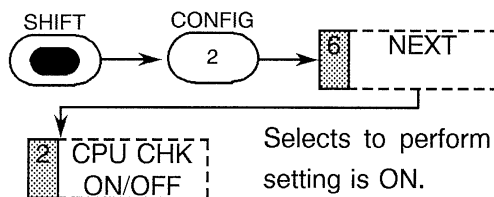

Press the keys in the left order.

Selects to perform or not perform CPU check at power-on. The initial setting is ON.

ON: CPU check (ROM/RAM check and display of the version) of this unit is performed. Therefore, some time is necessary to start up this unit.

OFF: CPU check of this unit is omitted. The minimum initialization is performed. Message "Initialize..." is displayed there.

When the unit is turned to ON and OFF over and over again, select CPU CHK OFF. The system can be set up in a short time.

CAUTION

When the action of this unit is abnormal, perform the CPU check again.

7.8.7 Battery Check Function

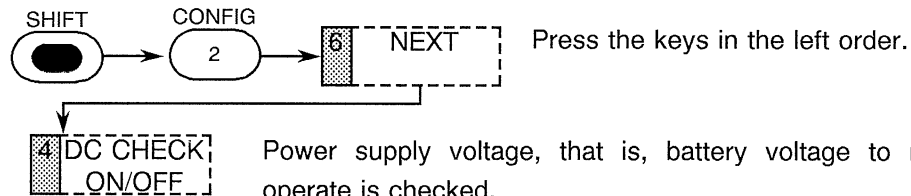

Power supply voltage, that is, battery voltage to make this analyzer operate is checked.

Turns on and off the battery check function. When this function is set to ON, the power supply voltage is displayed on the screen and the boundary value of the power supply voltage can be set.

The boundary value can be set between 10.0V and 12.0V, inclusive. If the power supply voltage becomes lower than the specified boundary value, the warning buzzer sounds and the display blinks.

When this function is set to OFF, the power supply voltage is not displayed. However, the power supply voltage decreases and when there is a possibility that the decreasing voltage (falling to about 10.2V) has an effect on the operation of this analyzer, the message as shown in Figure 7-44 is displayed.

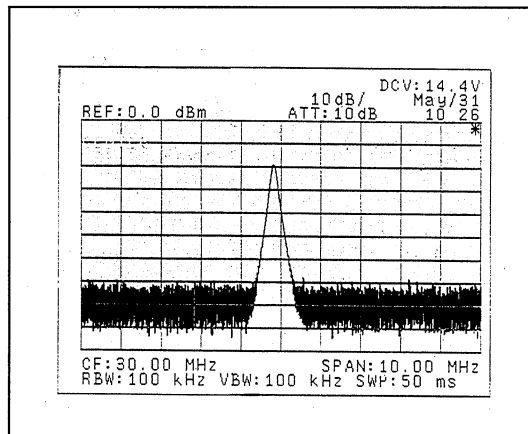

Figure 7-43 The power supply voltage is in a normal state at DC CHECK ON. When it is not in a normal state, the display blinks and the buzzer sounds.

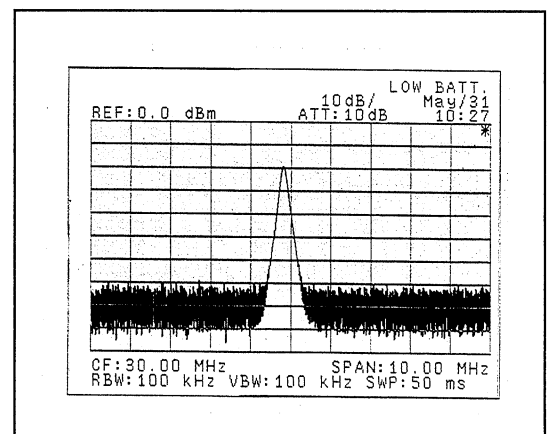

Figure 7-44 When the power supply voltage is low at DC CHECK OFF, the display blinks.

**SPECTRUM ANALYZER
OPERATION MANUAL**

7.8 Configuration (CONFIG) Function (Initialization Function)

ALARM LEVEL setting

Set an alarm level according to some kinds of available batteries.



Example of Ni-Cd battery

Type	Setting value (Final electric discharge voltage)	Remarks
14.4V	11.0V to 12.0V	PROPAC14
13.2V	10.0V to 11.0V	
12.0V	10.0V	

CAUTION

1. The battery check function operates only after each sweep has been complete.
2. When the power supply voltage cannot be monitored, **** is displayed.

(2) Printer/plotter output cancellation

Pressing    enables to cancel the printer/plotter output.

CAUTION

1. It is not possible to simultaneously output to both the printer and plotter.
2. If the output device is not completely, or correctly configured the copy function may not operate. Always check that CONFIG has been done.

**SPECTRUM ANALYZER
OPERATION MANUAL**

7.9 Copy Function

(This page has been intentionally left blank.)

7.10 Calibration Function

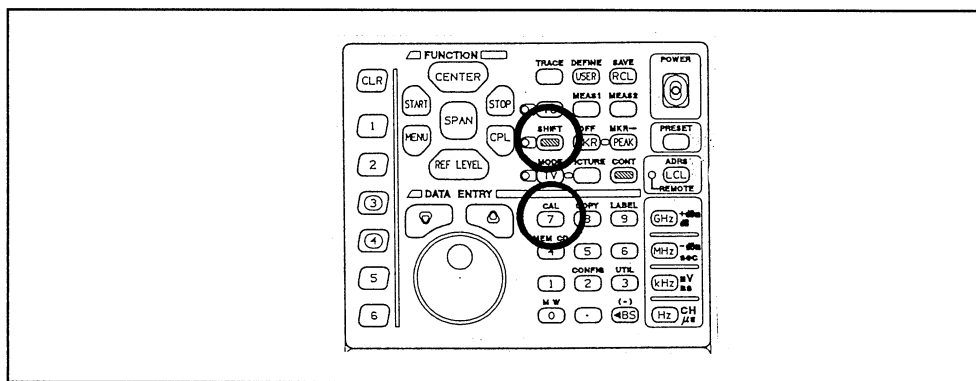





Figure 7-46 Calibration function key on Front panel



Calibration data for the analyzer can be obtained by using the Calibration Function. This data can then be used to correct the raw measurement data to achieve even more accuracy from the analyzer.

(1) Calibration Items

Calibration is done for any or all of the following seven items:

1. Absolute level error (resolution bandwidth 3 MHz, 1 dB/div, calibration reference signal -20 dBm).
2. Level error in switching IF filters (resolution bandwidth 1 kHz to 3 MHz (100 Hz and 300 Hz at Option)).
3. Vertical display linearity (LOG scales: 10 dB/div, 5 dB/div, 2 dB/div, and 1 dB/div).
4. Error in switching from LOG 10 dB/div to 1 dB/div.
5. Error in switching the IF STEP Amp.
6. Error in switching the input attenuator.
7. PBW (noise power bandwidth)

To execute the calibration of six items other than PBW, press   .

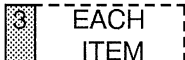
To calibrate an individual item, press    and then choose the one to be calibrated.

CAUTION

1. Always let the analyzer warm up for 30 minutes or more before calibration.
2. The internal calibration signal is automatically routed and switched inside the analyzer.

(2) Calibration Menu

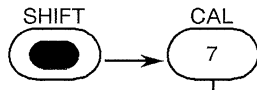

1 CAL ALL

Calibration can be carried out except items of PBW. Analyzer becomes error compensation mode after calibration is completed.

2 TOTAL GAIN

Measure the absolute level error using a resolution bandwidth of 3 MHz, scaling 1 dB/div. Calibration signal level -20 dBm.

3 EACH ITEM

Six items calibration can be carried out individually.

1 INPUT ATT

Measure the level error that arises when the input attenuator is switched, and correct for it.

2 IF STEP AMPTD

Measure the level error that arises when the IF Step Amplifier is switched, and correct for it.

3 RBW SWITCH

Measure the level error that arises as the IF Filter is switched to change resolution bandwidth, and correct for it.

4 LOG LINEAR

Measure the display vertical linearity in LOG scaling from 10 dB/div down to 1 dB/div. Correct for the error.

5 AMPTD MAG

Measure the level error that arises in LOG scaling when switching from 10 dB/div down to 1 dB/div. Correct for it.

6 PBW

Measure the noise power bandwidth using a resolution bandwidth of 1 kHz to 3 MHz (100Hz and 300Hz at option) and correct the noise level (NOISE/Hz) of marker.

**SPECTRUM ANALYZER
OPERATION MANUAL**

7.10 Calibration Function

4 CAL SIG
ON/OFF

Turn the internal 30 MHz, -20 dBm calibration signal On or OFF. The analyzer input section has an RF switch which selects either the normal front panel RF connector, or the internal calibration source.

The switch is usually operated automatically when calibration mode is entered and left, but it can also be manually controlled with this push button. When ON is selected, the calibration signal can be viewed on the display just as a standard input signal. If OFF is selected, then the calibration signal is cut off, and the normal RF input connector signal is displayed.

5 FREQ CORR
ON/OFF

Frequency characteristic calibration data is measured for each analyzer at the factory, and stored internally. When ON is selected here, the frequency calibration data is used to compensate measured data.

6 CAL CORR
ON/OFF

Choose whether or not to use the data collected by the CALIBRATION Function to correct raw measurement data.

7.11 Label Function

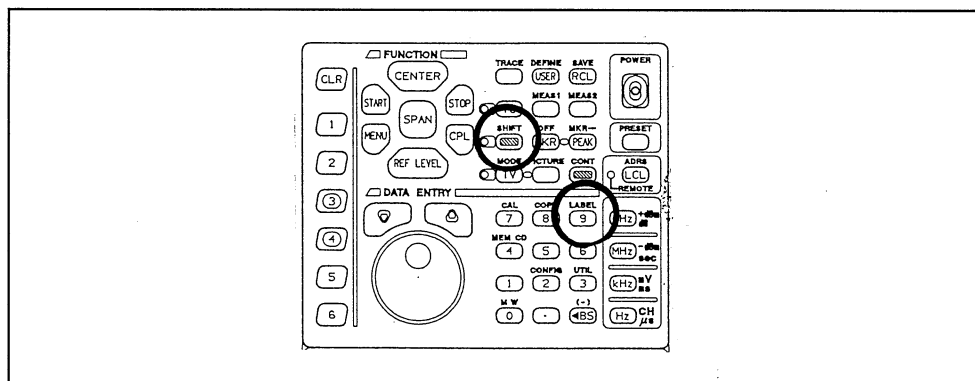



Figure 7-47 LABEL function key or Front panel

A display spectrum or waveform can be labeled with this function.
The input label can be used for a plotter output and a memory function.

(1) Labeling procedure

- ① Press  ,  and the label input screen (Figure 7-48) appears.

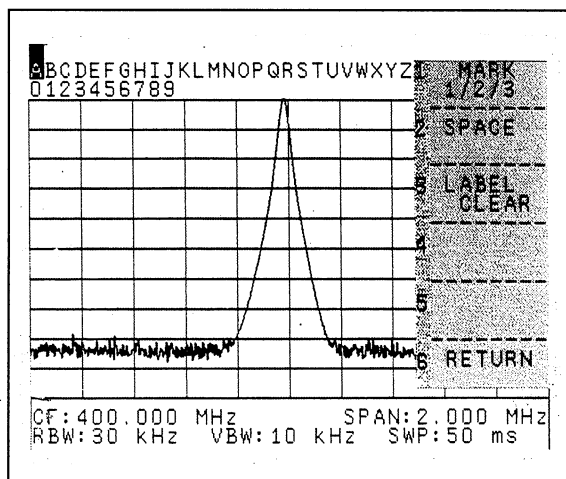





Figure 7-48 Label input screen

- ② The label location can be moved with the   step keys.
The cursor moves right when  is pressed, and left when  is pressed.

SPECTRUM ANALYZER
OPERATION MANUAL

7.11 Label Function

5 LBL DISP
ON/OFF

ON: Label display is made in the scale. See Figure 7-49. It is always displayed at the plotter/printer/video output.

OFF: Label display is not output to the screen. See Figure 7-50. When the plotter function is used, the label is displayed in the top of the screen.

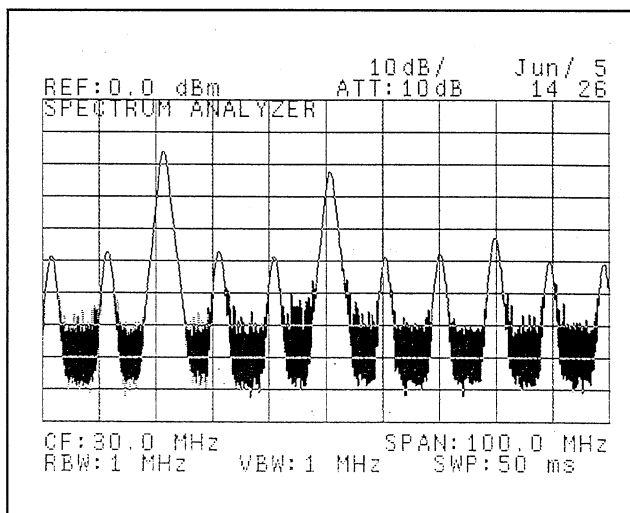

Figure 7-49 Label display ON

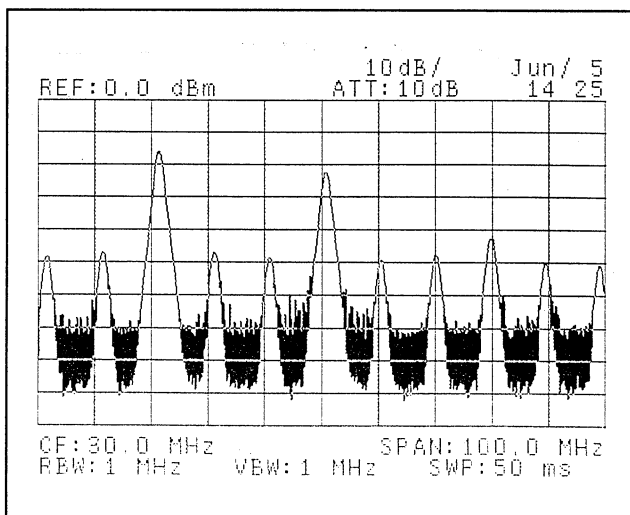

Figure 7-50 Label display OFF

6 RETURN

Return to the previous menu.

7.12 Utility Functions

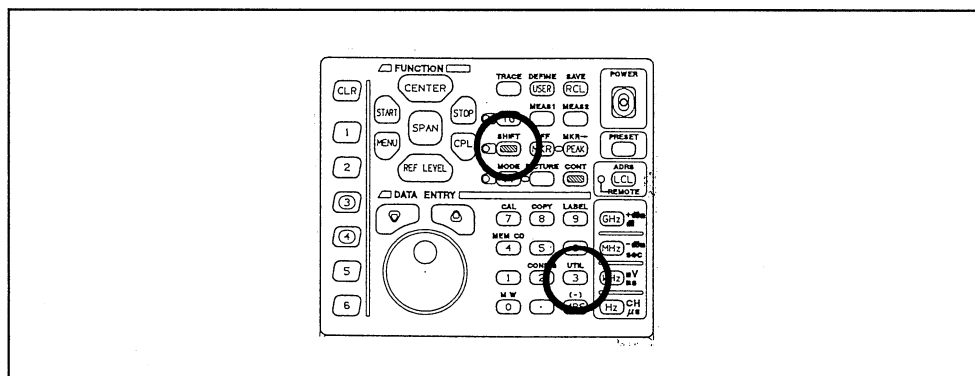

Figure 7-51 Front panel UTILITY function key

The utility menu provides access to the following functions:

1. Selection of a compensation antenna factor (arbitrary antenna factor data entry is also possible.)
2. Limit line function
3. Setup Go/No go tests using the limit lines

7.12.1 Antenna Factor Correction

When an antenna is used to measure the electric field intensity the raw data needs to be corrected for the actual sensitivity of the antenna. When the antenna factor is taken into account, a calibrated electrical field intensity measurement in $\text{dB}\mu\text{V}/\text{m}$ can be displayed directly.

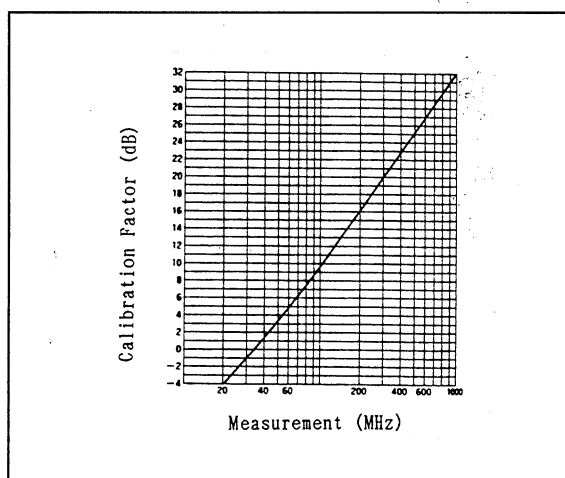
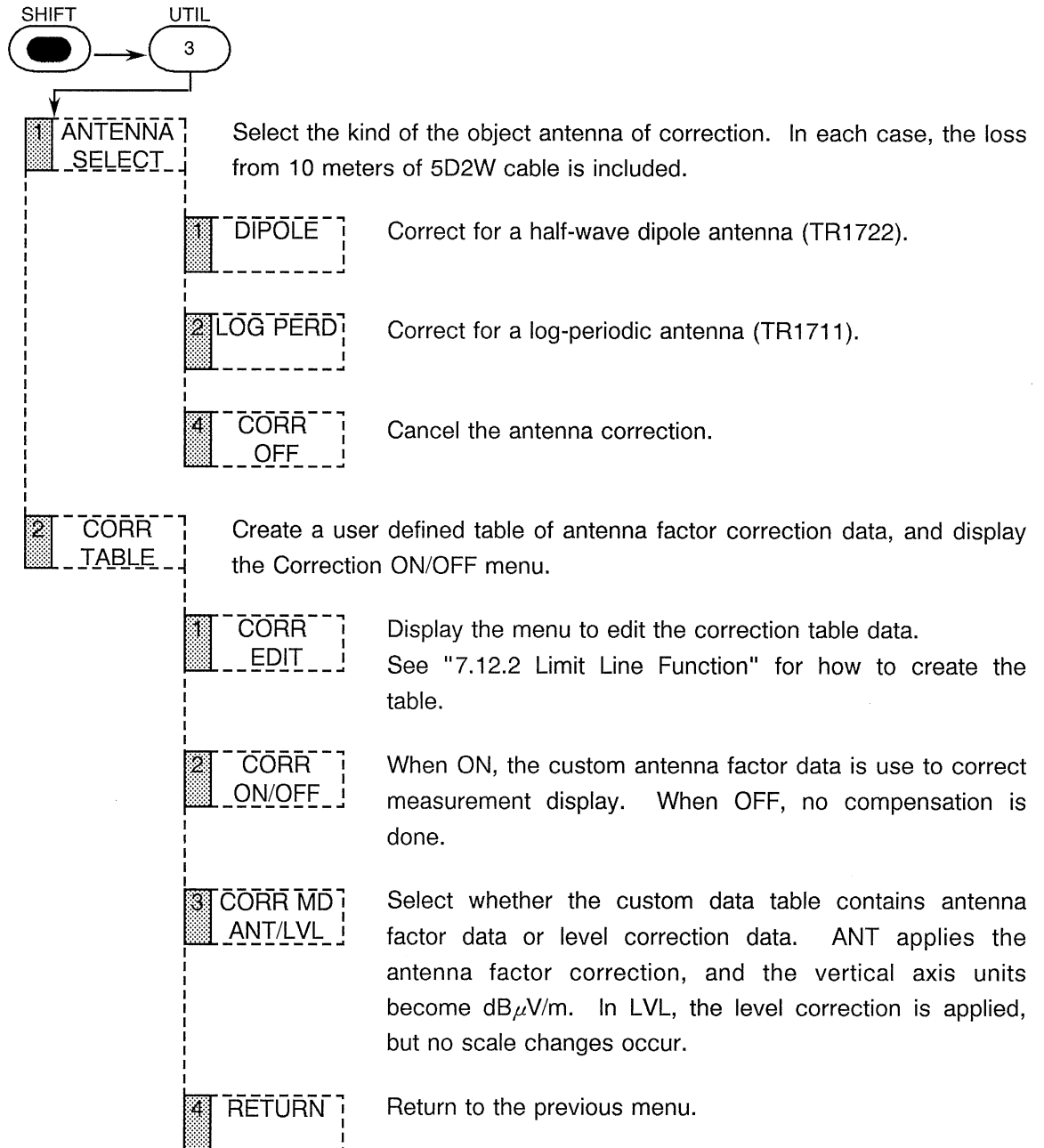

Figure 7-52 TR1722 antenna factor



CAUTION

The level data of the correction data table is available to input the range of -70.0 to +70.0 dBm. The total correction range of frequency characteristic correction, antenna correction, and correction table is ± 7 DIV on the screen.

For example, the total ± 7 dB (± 70 dB in 10 dB/DIV) is available in the 1 dB/DIV setting. If the correction exceeding this range is conducted, an error message is displayed.

the analyzer's dynamic range on the screen will be degraded if the level correction is conducted to the minus direction.

7.12.2 Limit Line Function

The limit line function displays two lines on the display; they could be set for example, to show permissible upper and lower bounds on the spectral amplitudes. In any case, comparison of measured data with the limit lines is very easy.

(1) Limit line data table entry

There are two independent limit lines, 1 and 2. Each limit line can be defined either in the frequency or time domains. The defining tables contain up to 51 data pairs, each associating a frequency or time point, to a level. Frequency points can be from -99.999999999 GHz to 999.999999999 GHz, times from 0 to 1000 seconds, and levels specified in the range -240 to +100 dBm. Level data can also be entered in the same units as the reference level (except for the units of V or W).

There are two modes of accessing the data tables; a normal entry mode for the initial table creation, and an edit mode for modifying an existing limit line.

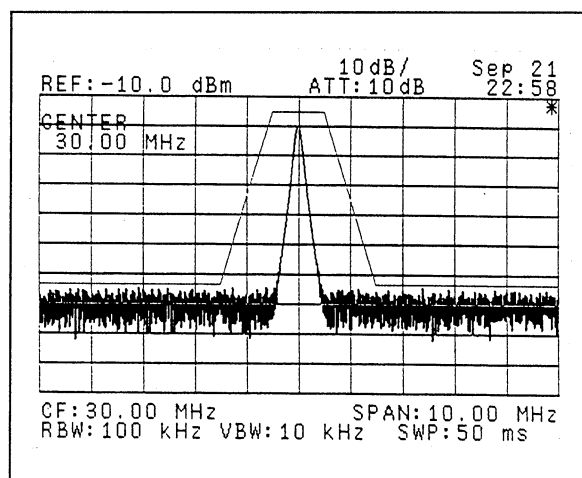
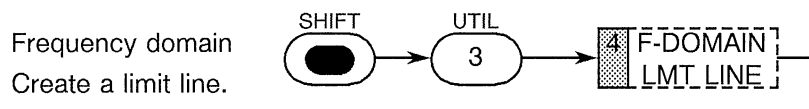

Figure 7-53 Limit line data entry

(2) Limit line menu



1 LIMIT LINE 1

2 LIMIT LINE 2

3 FREQ ABS/REL

4 LEVEL ABS/REL

5 LIMIT 1 ON/OFF

6 LIMIT 2 ON/OFF

Enable the limit line, 1 or 2, and go to data entry mode. The data table can be scrolled with the data knob  and the step keys.

Frequency data input points should be absolute or relative data. Relative values are with respect to the center frequency.

Level data input points should be absolute or relative data. When the display line is present, relative values are with respect to it. Otherwise they are with respect to the reference level.

Enable (ON) or disable (OFF) the display of the corresponding limit line 1 or 2.

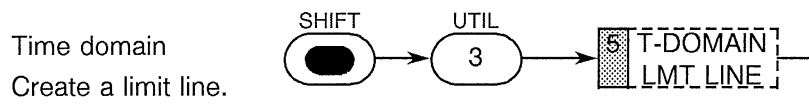

1 LIMIT LINE 1

2 LIMIT LINE 2

3 TIME ABS/REL

4 LEVEL ABS/REL

5 LIMIT 1 ON/OFF

6 LIMIT 2 ON/OFF

Enable the limit line, 1 or 2, and go to data entry mode. The data table can be scrolled with the data knob  and the step keys.

Time data input points should be absolute or relative data. When the delay sweep is on, absolute values are with respect to the delay position. Otherwise, absolute values and relative values are with respect to the leftmost side of the screen.

Level data input points should be absolute or relative data. When the display line is present, relative values are with respect to it. Otherwise they are with respect to the reference level.

Enable (ON) or disable (OFF) the display of the corresponding limit line 1 or 2.

(3) Limit Line data table creation

The method of creating the data table is the same for both the frequency domain and time domain limit line. Also, the same procedure is used to enter the data for the antenna factor correction data of section "7.13.1 Antenna Factor Correction". Data entry (or edit) mode is set by one of the following key press sequences:

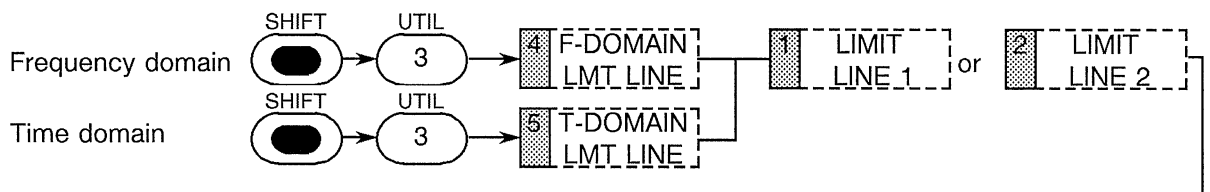

In any case, a data table edit display such as shown in Figure 7-54 will appear. Enter the frequency (or time) and then the level for each point, as each pair is entered that data point is defined in the table. The data points are read from the table in ascending order of frequency (or time).

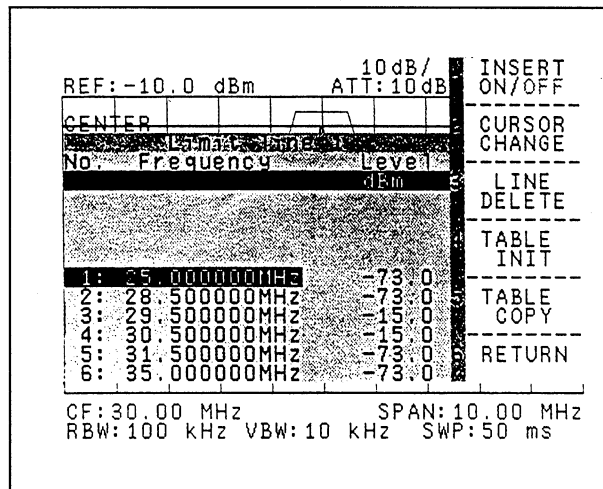
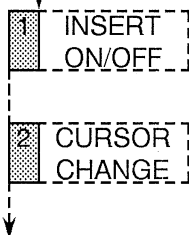

Figure 7-54 Table edit mode



When ON is set, a new empty line is put into the table, and data values are prompted for. The entire data entry process can be done in this mode if you desire a prompt for each entry.

Switch the cursor between frequency (or time) and level data fields.

3	LINE DELETE	Delete the line pointed to by the cursor.
4	TABLE INIT	Clear all the data in the table.
	1 CONFIRM	Confirm the destruction of the table.
	6 CANCEL	Abort the table initialization request, return to the table edit menu.
5	TABLE COPY	Only for limit line tables. Copy the displayed limit line data to the other limit line table.
	1 CONFIRM	Confirm overwriting the opposite data table.
	6 CANCEL	Cancel the copy request and return to the table edit menu.
6	RETURN	Return to the previous menu.

CAUTION

1. A limit line data table can only contain frequency domain data points, or time domain data points; they cannot be mixed in a single table. If there are already frequency domain data points and you do try to make a time domain entry, the following display will appear:

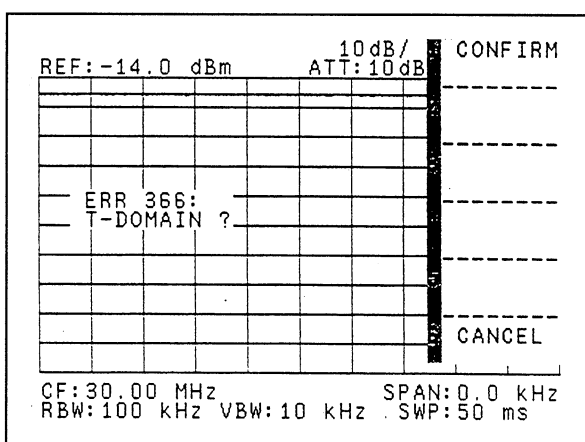

At this point, you can push CONFIRM that you want to delete the previous data and continue with the time domain data entry.

2. Even though the limit line display has been enabled, if the limit line domain (frequency or time) is not the same as the current screen display mode, then the limit line will not be displayed.

7.12.3 PASS/FAIL Function (Display Trace Go/No go Test Function)

A Go/No go test for the display trace can be done using the limit line function.

Note : This function is effective only in Trace A.

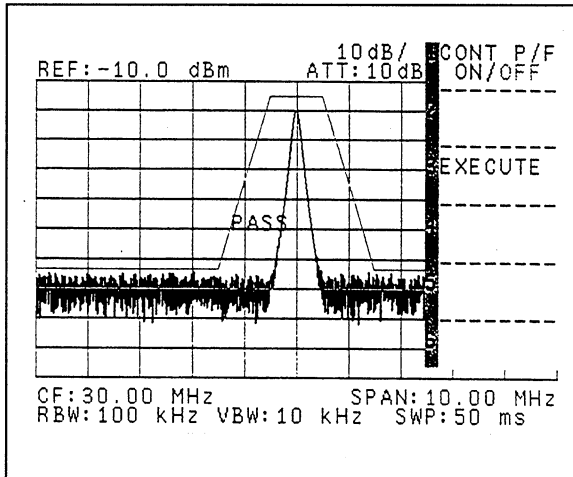

Figure 7-55 PASS/FAIL function
(Using a single limit line.)

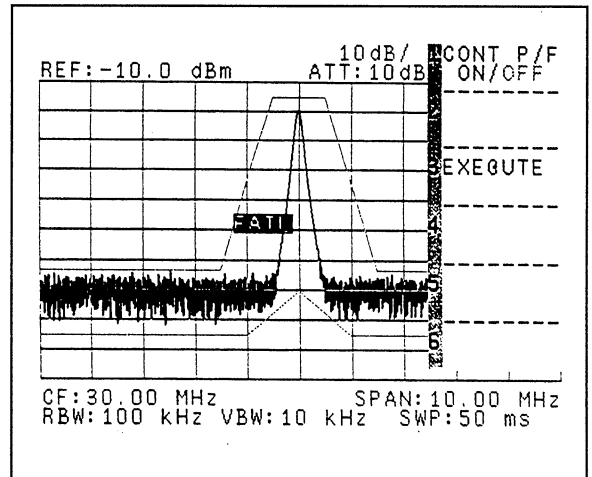
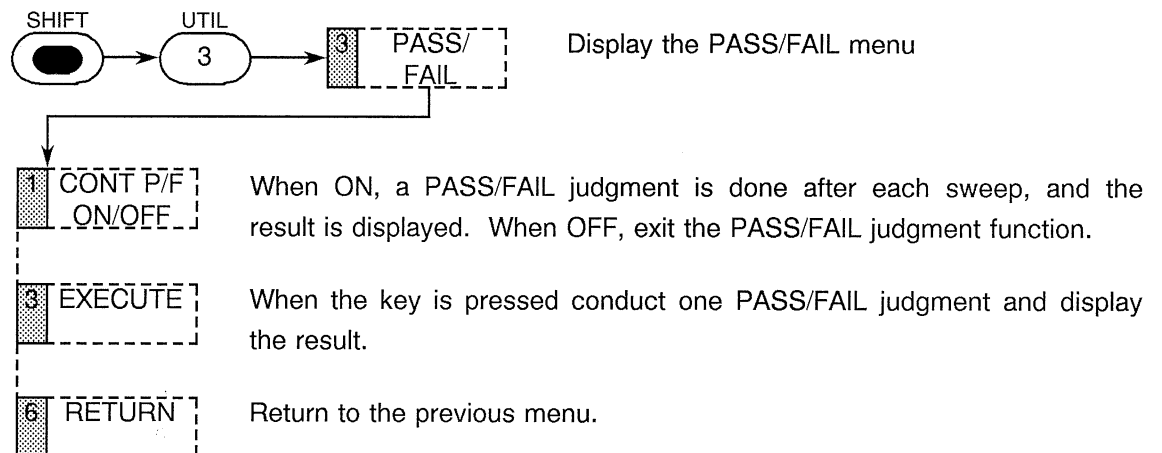

Figure 7-56 PASS/FAIL function
(Using both limit lines.)

When only a single limit line is used to establish the pass/fail criterion, if the spectrum or waveform is always below the limit line then it PASSES, otherwise it FAILS. When two limit lines are used, then the spectrum or waveform PASSES if and only if it is totally confined between the two limit lines.

(1) Menu explanation



CAUTION

1. If one or both limit lines are not defined then the PASS/FAIL function will not operate.
2. When using both limit lines for PASS/FAIL, always arrange the data so that Limit Line 1 will appear above, and Limit Line 2 below the trace to be tested.

7.13 Measurement Window Function

By using a measurement window it is possible to make fast measurements inside the window even while displaying a very wide frequency span.

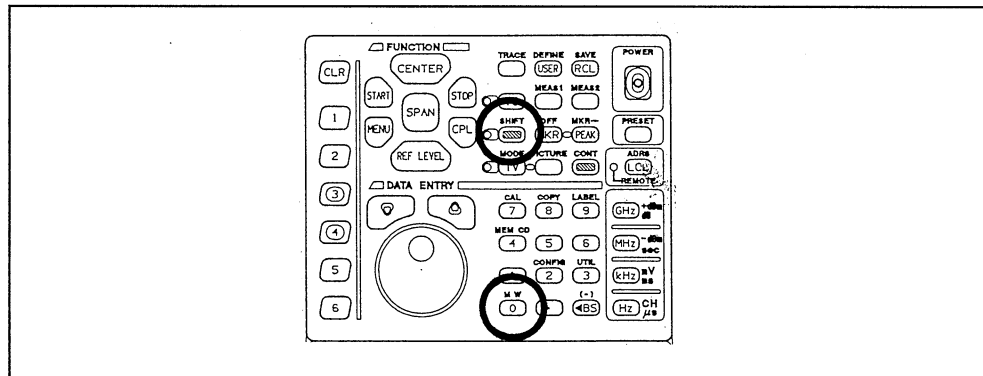



Figure 7-57 Front panel measurement window function key

Press   to display the initialization screen shown below (Figure 7-58).

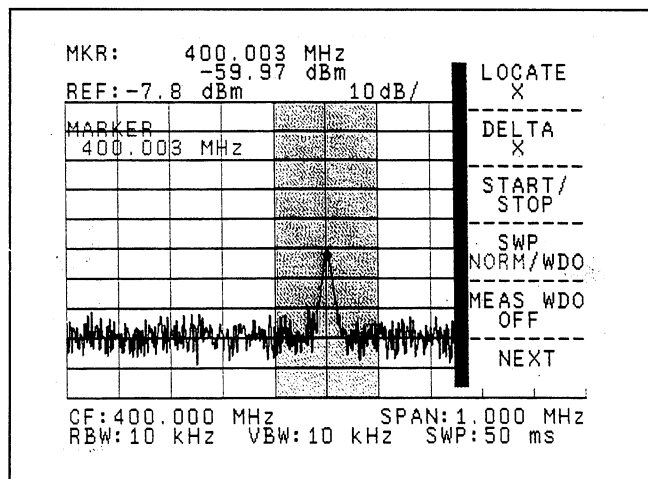
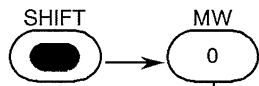
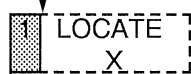

Figure 7-58 Measurement window initialization screen

(1) Window horizontal axis direction and window sweep setup



Display the measurement window softmenu.
When Softmenu disappears (display *), display the measurement window.
Pushing the following keys each time to display alternately the window frequency and the window width and enables to input.



Locate the window position according to the horizontal direction.
Enter the frequency (or time) data and using the numeric key and units keys, the step keys, or the data knob . (See Figure 7-59.)



Reduce the horizontal axis width of the window (ΔX).
Enter the frequency (or time) data and using the numeric key and units keys, the step keys, or the data knob . (See Figure 7-60.)

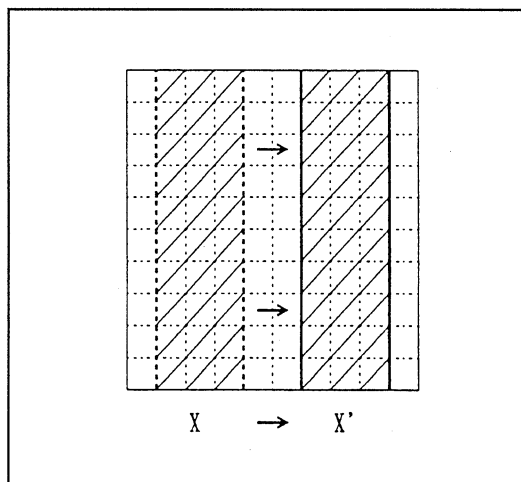

Figure 7-59 Window position movement ($X \rightarrow X'$)

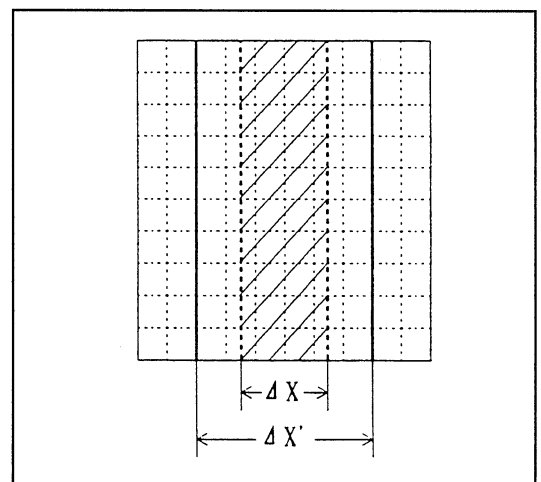

Figure 7-60 Window width increase/decrease ($\Delta X \rightarrow \Delta X'$)







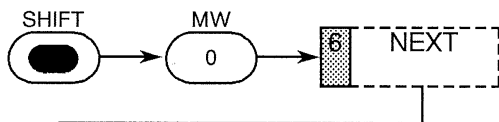

Toggle the window START/STOP frequency (or Time) data.
When START is selected, window START frequency (or Time), and STOP for window STOP frequency (or time) can be set.
Enter the frequency (or time) data and using the numeric key and units keys, the step keys, or the data knob .

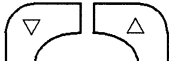
4 SWEEP NORM/WDO	Toggle the sweep (window sweep) inside the measurement window. When WDO is set, sweep only inside the measurement window. In NORM stop the window sweep and sweep normally.
5 WINDOW OFF	Delete the window display. If any measurements are in progress that use the window they are also canceled at that point.
6 NEXT	Display the horizontal movement menu and the increase/decrease menu.

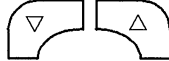
(2) Window vertical axis direction window sweep setup

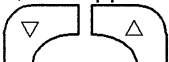

1 LOCATE Y	Move the window position to the vertical axis direction with the   step keys or the data knob  .
2 DELTA Y	Increase/Decrease the window vertical axis width (ΔY) with the   step keys or the data knob  .
3 UPPER/ LOWER	Toggle the UPPER/LOWER level of the window. When UPPER is selected, the upper level can be moved with the numeric key and units keys, the   step keys, or the data knob  .
6 RETURN	Return to the previous menu.

(3) Measurement example using the window

When the window is opened, the measurement area is set to only inside the window for sweep or marker function. Thus it is possible to define the measurement time (SWEEP) or search area (Marker).

The following items can be measured.

- ① Window sweep

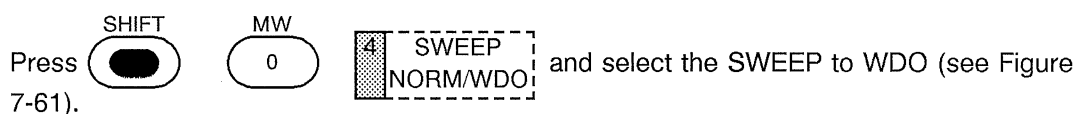

- ② Peak search inside the window

Same as MIN search, continuous search (see Figure 7-62).

- ③ NEXT peak search inside the window

Same as NEXT PK RIGHT, LEFT, and MIN.

- ④ X dB down inside the window

Same as LEFT, RIGHT, and continuous dB down.

- ⑤ 3rd order modulation distortion measurement

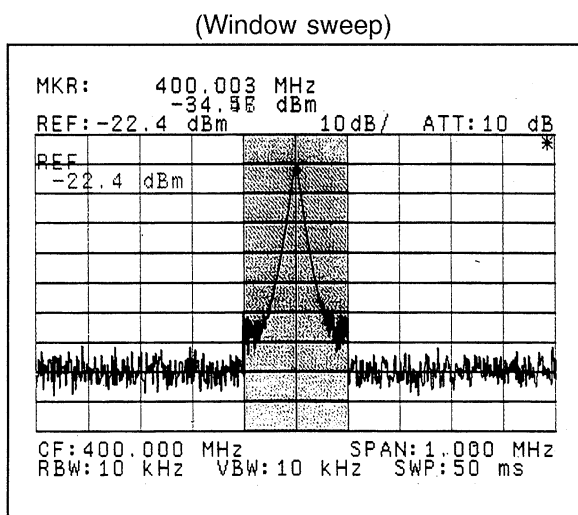

Figure 7-61 Partial sweep inside the window

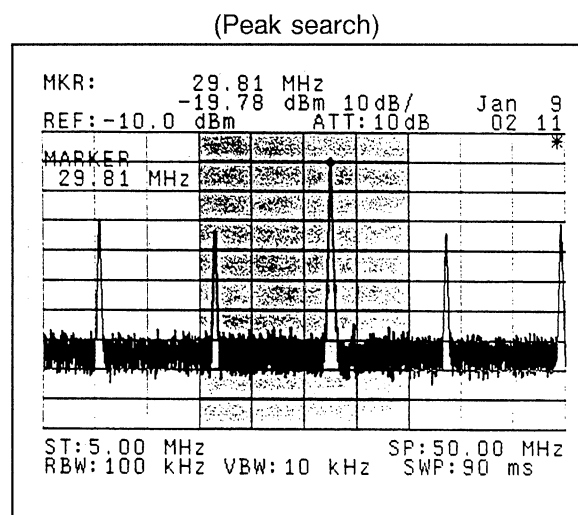

Figure 7-62 Continuous peak search inside the window

8. TV MONITOR FUNCTION (OPT-72)

8.1 Notes on Using TV Monitoring Function

RF wide band preamplifier have no selectivity of input frequency unlike general TV receiver. So, take care on saturation and distortion of the input pre-amp for the multiple-channel signal. Use an external attenuator, filter and so on as required.

(1) For single-channel signal input

The relationship between input signal level and S/N ratio is shown in Fig. 8-1.

- Using a pre-amp improves S/N ratio. (Because RF block down conversion degrade S/N ratio.)
- When a pre-amp is used, 1dB-gain compression is $+80\text{dB}\mu\text{V}$. If the input level more than $+80\text{dB}\mu\text{V}$ is applied, the synchronization may be unstable, picture may have watering or sound in picture.

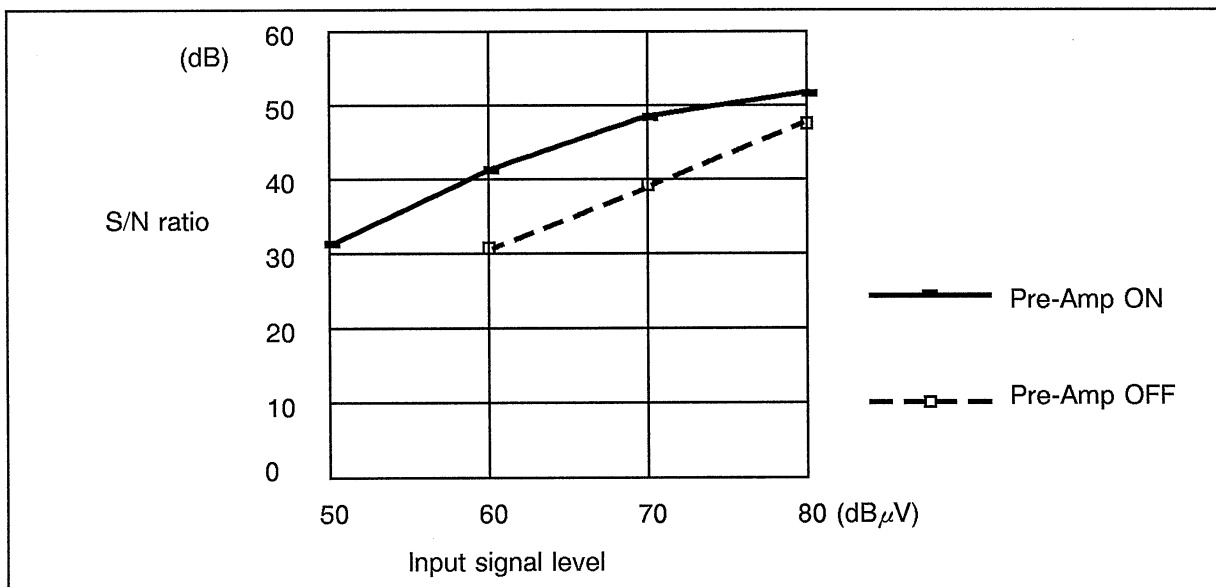

Figure 8-1 Relationship between input signal level and S/N ratio

(2) For multiple-channel input

- In the case C/N is not improved when the pre-amp is used, the pre-amp is saturated. Use an external attenuator or a filter so that the total input power of the pre-amp will reach the order of -35dBm ($+75\text{dB}\mu\text{V}$).

**SPECTRUM ANALYZER
OPERATION MANUAL**

8.1 Notes on Using TV Monitoring Function

- When the video-carrier signal level of one channel is 40 to 70dB μ V as a guide.: The pre-amp can be used with powered on.
- When the signal level is 80dB μ V or more.: The pre-amp is saturated. Reduce the signal level with an external attenuator or turn off the pre-amp. (Set the input attenuator to 0dB.)
- Example for using pre-amp

For low input level: The C/N ratio is improved. So, the S/N ratio of the modulated signal is improved.

Pre-amp OFF

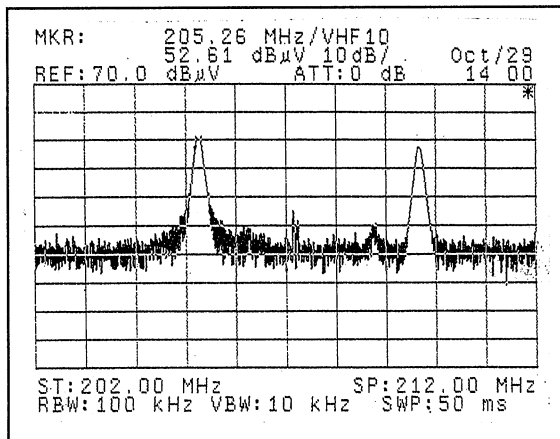

Pre-amp ON

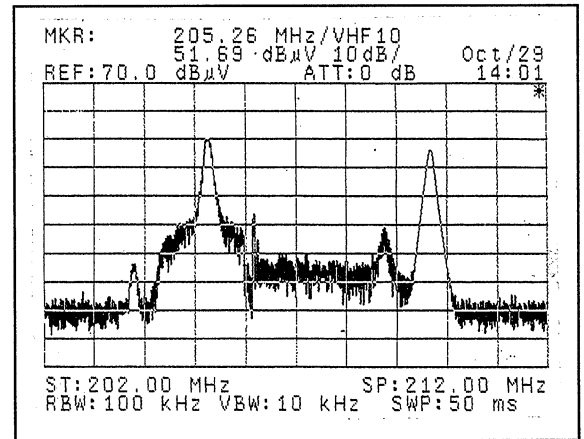

For high input level: The C/N ratio is declined. The picture quality is declined because of appearance of distortion in the video band.

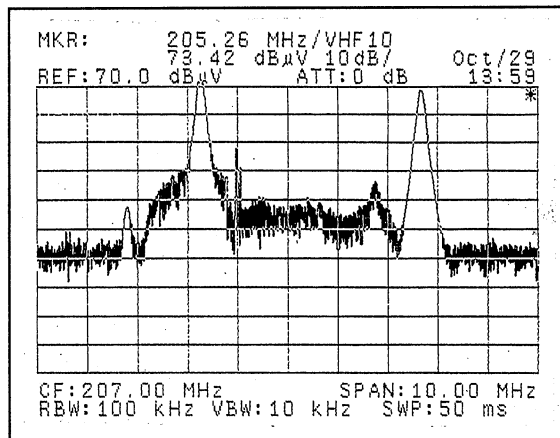

Pre-amp OFF

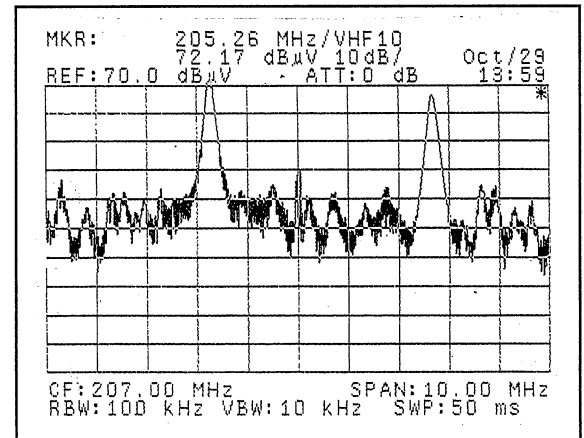

Pre-amp ON





8.2 Display of TV Monitor Screen (PICTURE Key)



When  is pressed, spectrum screen changes to TV monitor screen by pressing  again, spectrum screen returns.

(Note) Using an external video monitor on video COMP output allows to have always measuring analyzer's screen.

On TV monitor screen in the channel input mode, the channel received on the screen and the possible/impossible to input channel are displayed on the top left (Fig. 8-2).

If the channel input mode is not selected, press .

When the channel input cannot be done as Fig. 8-2 (b), press ,

 or . If there is no channel number to be applied as Fig. 8-2 (c), no channel number is displayed.

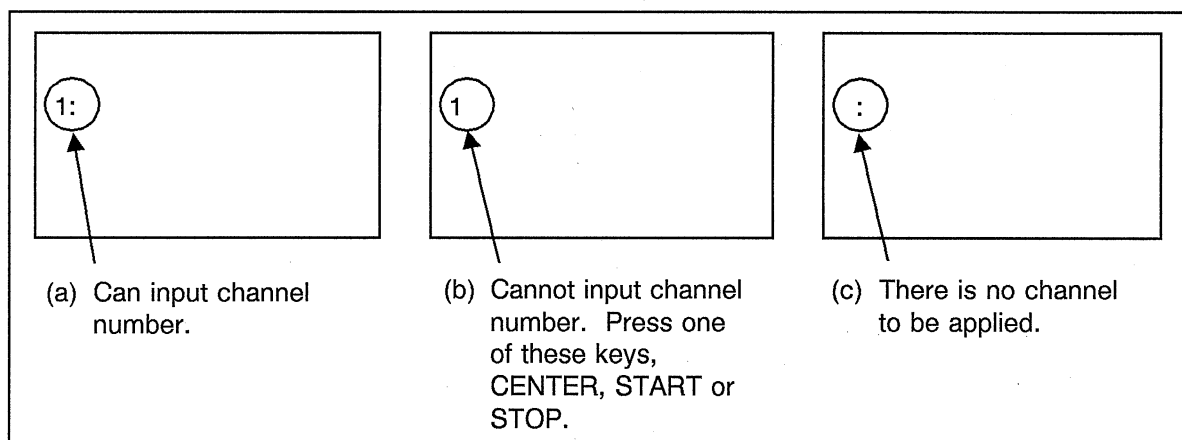

Figure 8-2 Indications and input of channel number

On TV monitor screen, the sweep mode is set to manual.



**SPECTRUM ANALYZER
OPERATION MANUAL**

8.2 Display of TV Monitor Screen (PICTURE Key)

(Note) • When channel is input, the marker is moved to the picture frequency of input channel automatically. Auto-tuning is executed to the audio frequency too. But if the manual sweep has been set before TV monitor screen is set, auto-tuning is not executed.

When the tuning is done with the marker to display the best picture, press

 to display "TUNING" on TV monitor screen. And execute



tuning with data knob  or  or  step keys.

- On TV monitor screen, SOUND function (AM/FM) does not work. TV audio demodulation is preceded.
- During TV monitor screen, if the COMP video output is input to the external monitor, the spectrum screen can be seen.

For Channel setup, refer to the section 9.1 and 9.2.

For Frequency setup, refer to the section 9.3.

8.3 Adjustment of TV Monitor Screen (SHIFT Key + PICTURE Key)

Press   , the menu to adjust TV monitor picture is displayed.

(Note) The menu is displayed only during TV monitor screen.

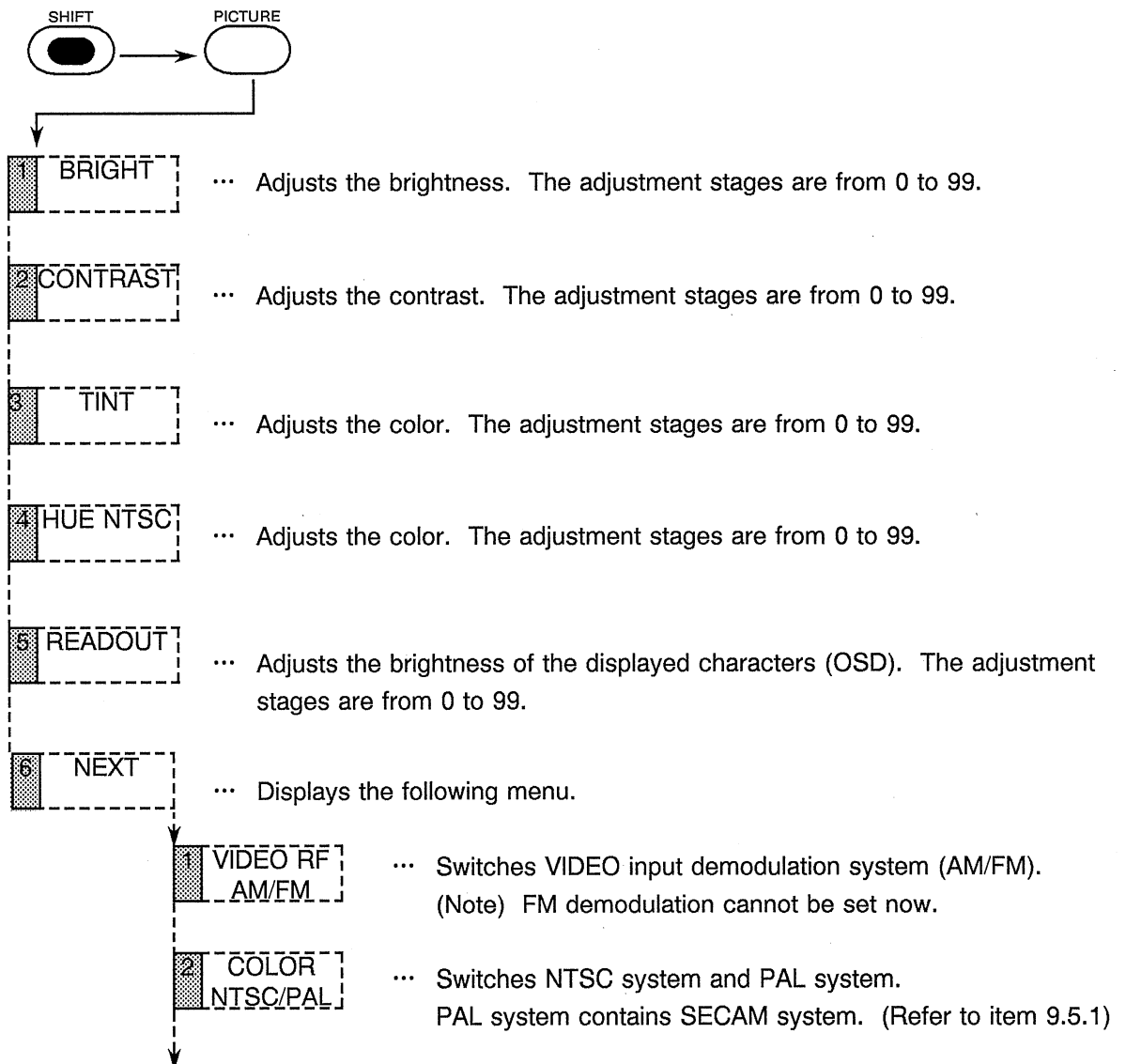

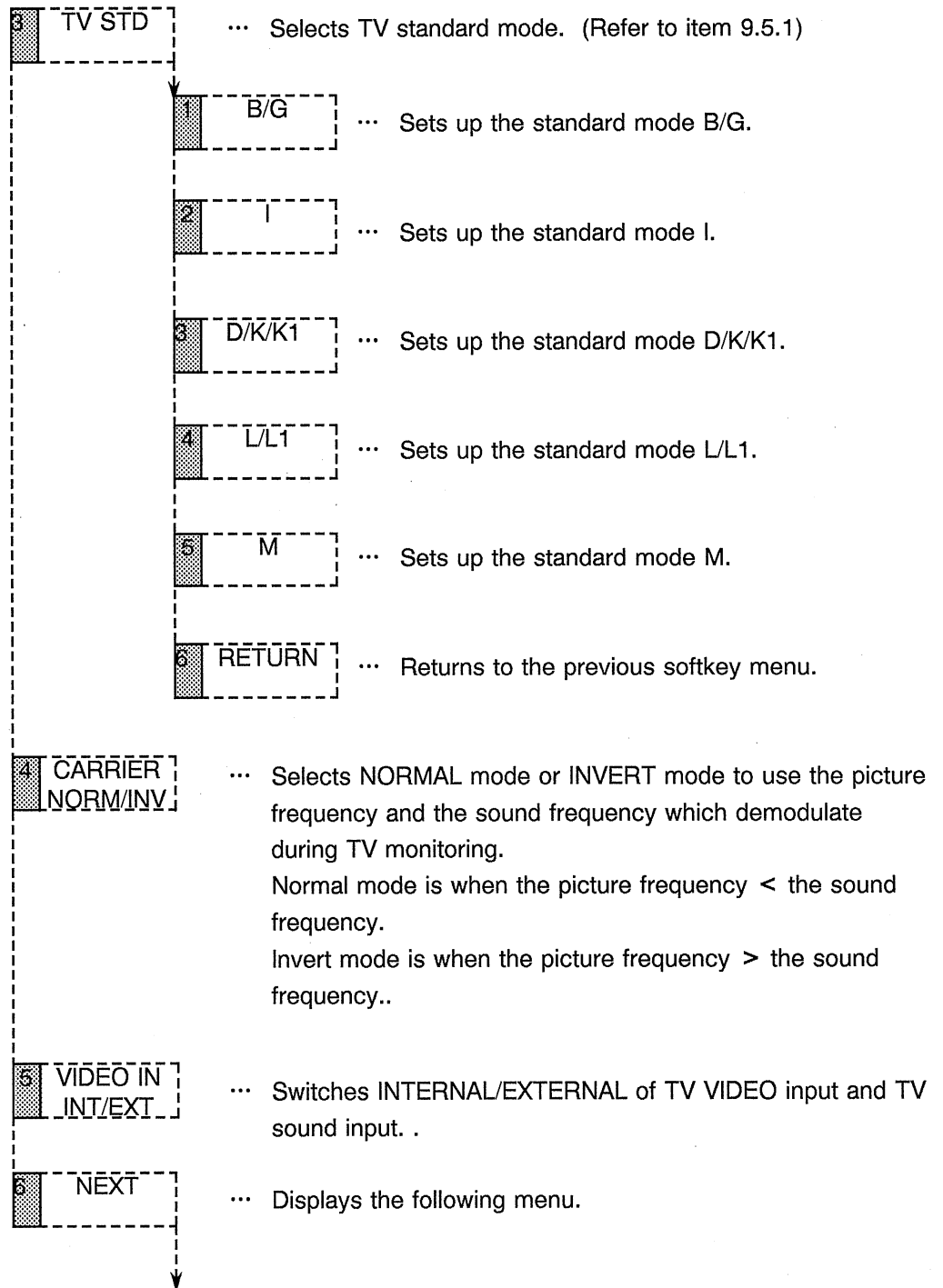

8.3 Adjustment of TV Monitor Screen (SHIFT key + PICTURE key)

TUNT LVL ... Displays the tuning level. The level of the demodulated picture frequency and the condition of the preamplifier (ON/OFF) are displayed on the OSD. (See Figure 8-3.)
ON/OFF ...

ON : The tuning level and the condition of preamplifier (ON/OFF) are displayed.
OFF : The tuning level and the condition of preamplifier (ON/OFF) are not displayed.

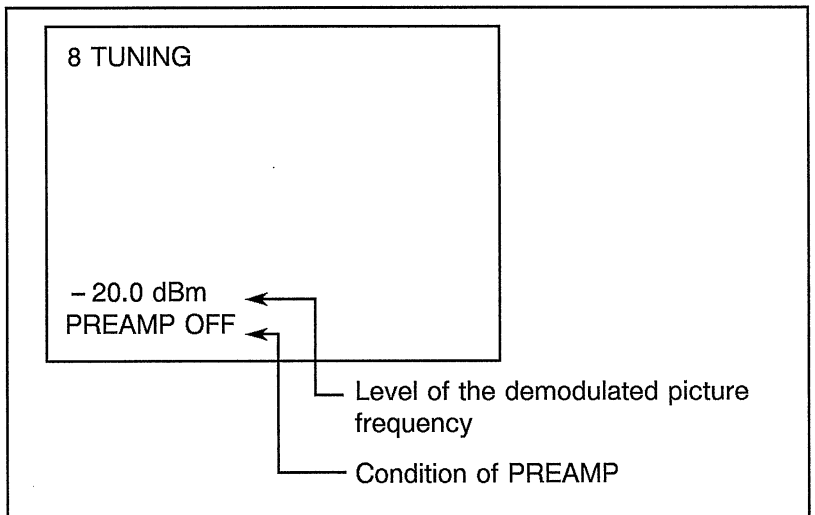

Figure 8-3 Tuning level display

RETURN ... Return to the previous menu.

9. TV CHANNEL FUNCTION (OPT-72, OPT-78)

9.1 Channel Setup (TV Key)

The analyzer can measure each channel's picture carrier frequency and sound carrier frequency at the same time by setting TV and CATV channel in channel input mode. Moreover, it can measure multi-channels at the same time.

User table (the table to define channels optionally) is ready to set up channel easily.

(1) Picture frequency setup

There are 2 ways to input channel. Refer to the section 9.3 'Channel Auto Function'.

(2) START frequency/STOP frequency setup

START frequency is the best value determined by the lower limit of frequency bandwidth of the input channel number. STOP frequency is the best value determined by the upper limit of frequency bandwidth of the input channel number. Set up each best value. See Fig. 9-1.

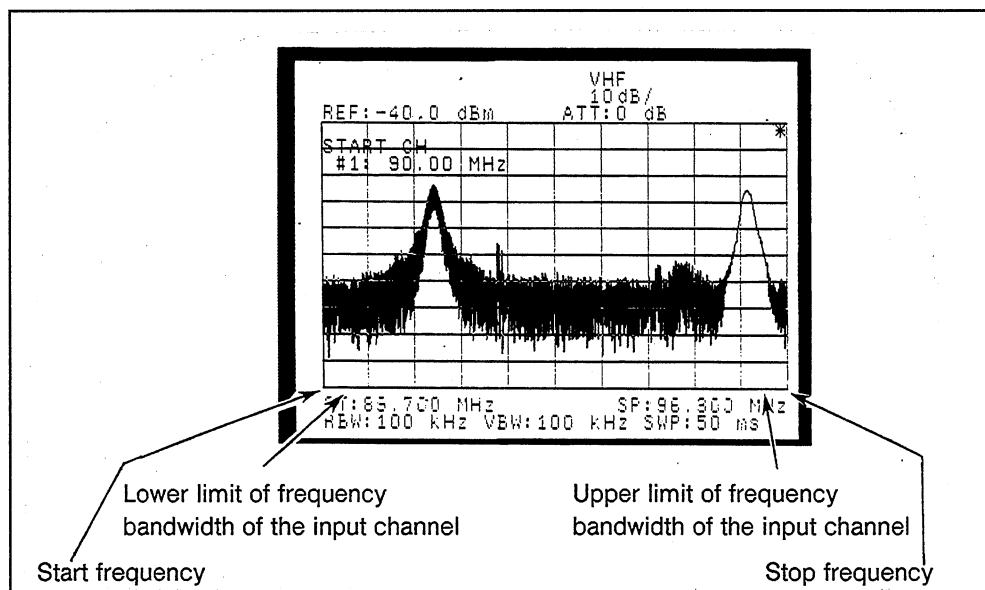

Figure 9-1 Start frequency/Stop frequency setup

The relation between START frequency and STOP frequency is always "START frequency < STOP frequency". Fig. 9-2 shows the setup example "Lower Limit and Upper Limit of Frequency Bandwidth".

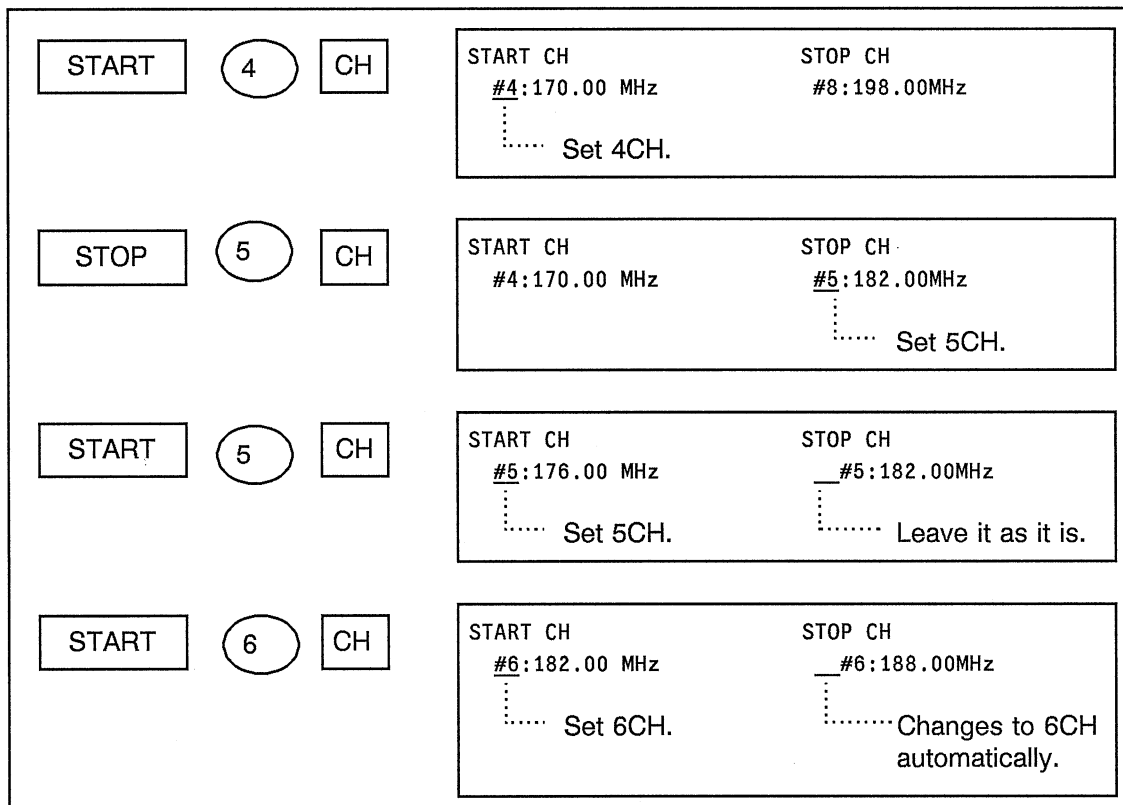

Figure 9-2 Relation between lower limit and upper limit of frequency bandwidth

- (3) In the case that the on-screen data is different from the current set value.

If the picture/center frequency (best value of lower limit/best value of upper limit) of the specified channel is different from the present setup center frequency (START/STOP frequency), displays a message in the active area as Fig. 9-3 shows to indicate that the present setup frequency is different.

<p>① Set the present setup channel 1CH. (Center frequency 91.25MHz)</p>	<div style="border: 1px solid black; padding: 5px;"> <p>CENTER CH #1: 91.25 MHz</p> <p style="text-align: center;">┌───┐ │ │ └───┘</p> <p style="text-align: right;">Picture frequency Channel</p> </div>
<p>② Set the frequency input mode to input center frequency 93.0MHz.</p>	<div style="border: 1px solid black; padding: 5px;"> <p>CENTER 93.0 MHz</p> </div>
<p>③ Switch to Channel input mode.</p>	<div style="border: 1px solid black; padding: 5px;"> <p>CENTER CH #1: Last Setup</p> <p style="text-align: center;">┆</p> <p style="text-align: center;">Because the present setup center frequency is different from the picture frequency of channel 1. The present setup frequency is 93.0MHz.</p> </div>
<p>④ Set the setup channel 1CH.</p>	<div style="border: 1px solid black; padding: 5px;"> <p>CENTER CH #1: 91.25 MHz</p> </div>

Figure 9-3 Difference between the present setup value and the displayed value

- (4) The case when no channel is set in user mode.
Displays a message in the active area to indicate that the user channel is not setup. Fig. 9-4 shows the example.

<p>User channel is not setup. Use editor to setup the picture frequency and the frequency bandwidth.</p>	<div style="border: 1px solid black; padding: 5px;"> <p>CENTER CH #?: No Setup</p> </div>
--	---

Figure 9-4 Display when user table is not set

(5) Difference of two user modes (USER and USER2)

In the USER mode, the order of frequency has precedence over the order of channel numbers. Therefore, data may not be set in order of channel number.

Example: When the table is set as shown in Figure 9-5 and the step key is pressed or the data knob is turned, the following setting is made.

1. Set 1 as the channel number (CENTER CF) using a numeric keypad.
2. When the UP key is pressed or the data knob is turned clockwise, the channel number is set to 3-2-4 in the order.

In the USER2 mode, channels and frequency are set in order of the set table.

Example: When the table is set as shown in Figure 9-6 and the step key is pressed or the data knob is turned, the following setting is made.

1. Set 1 as the channel number (CENTER CF) using a numeric keypad.
2. When the UP key is pressed or the data knob is turned clockwise, the channel number is set to 3-2-4 in the order.

REF: 0.0 dBm	USR 10dB/	DELETE
ATT: 10dB	USER CHANNEL TABLE	-----
TITLE: Japan (USR)		-----
CH	V. Carrier & Ch Limit	TABLE
		INIT
1:	91.250MHz 90.000MHz - 96.000MHz	-----
2:	103.250MHz 102.000MHz - 108.000MHz	-----
3:	97.250MHz 96.000MHz - 102.000MHz	TITLE
4:	171.250MHz 170.000MHz - 176.000MHz	RETURN
5:		-----
6:		10.00 MHz P: 50 ms

Figure 9-5 USER table

REF: 0.0 dBm	US2 10dB/	DELETE
ATT: 10dB	USER2 CHANNEL TABLE	-----
TITLE: Japan (US2)		-----
CH	V. Carrier & Ch Limit	TABLE
		INIT
1:	91.250MHz 90.000MHz - 96.000MHz	-----
2:	103.250MHz 102.000MHz - 106.000MHz	-----
3:	97.250MHz 96.000MHz - 102.000MHz	TITLE
4:	171.250MHz 170.000MHz - 176.000MHz	RETURN
5:		-----
6:		10.00 MHz P: 50 ms

Figure 9-6 USER2 table

9.1.1 Operation: method

Pressing **TV** to light LED, the mode is switched to channel input mode. On the screen, channel inputtable band is displayed.

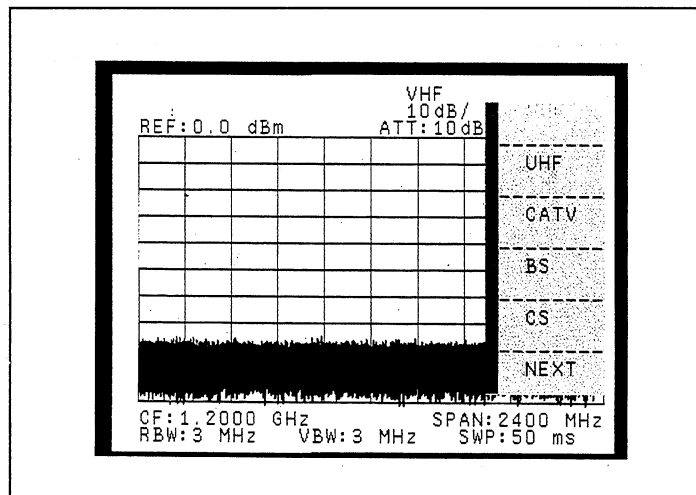
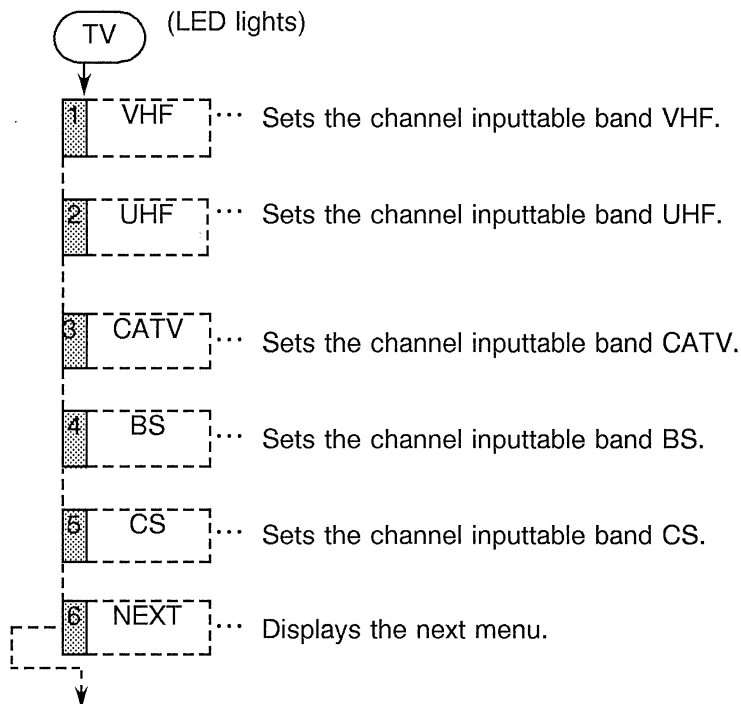
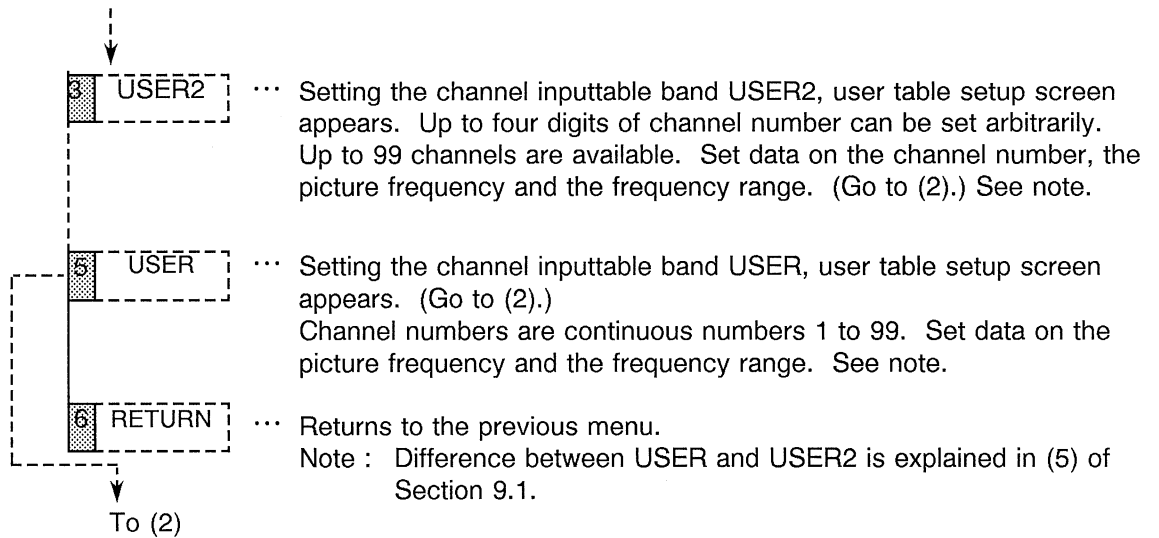

Figure 9-7 Channel input mode screen

(1) Channel setup





(2) User table setup

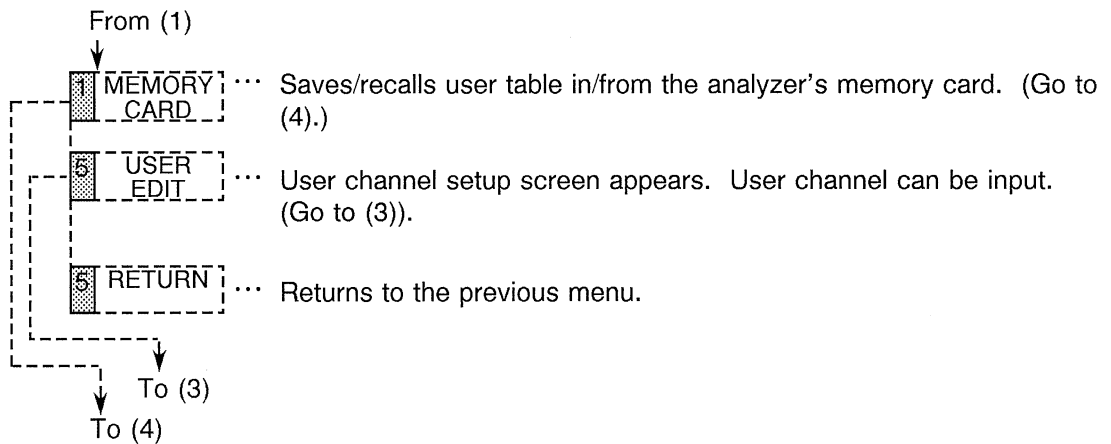

(3) User channel setup

Set the table name within 15 characters.

Set the name of band display. Present display is the initial value.

Displays inputtable channel.

Displays inputtable frequency.

Picture frequency.

Upper limit and lower limit.

USER

Set the table name within 15 characters.

Set the name of band display. Present display is the initial value.

Channel number.

Picture frequency.

Upper limit and lower limit.

USER2

0 to 9 : Input upper limit and lower limit of channel frequency range and the picture frequency. and Unit key

▽ ▲ : Select the data to input (Upper limit, Lower limit, Picture frequency).

○ : Select the channel to input.

Figure 9-8 User channel setup screen

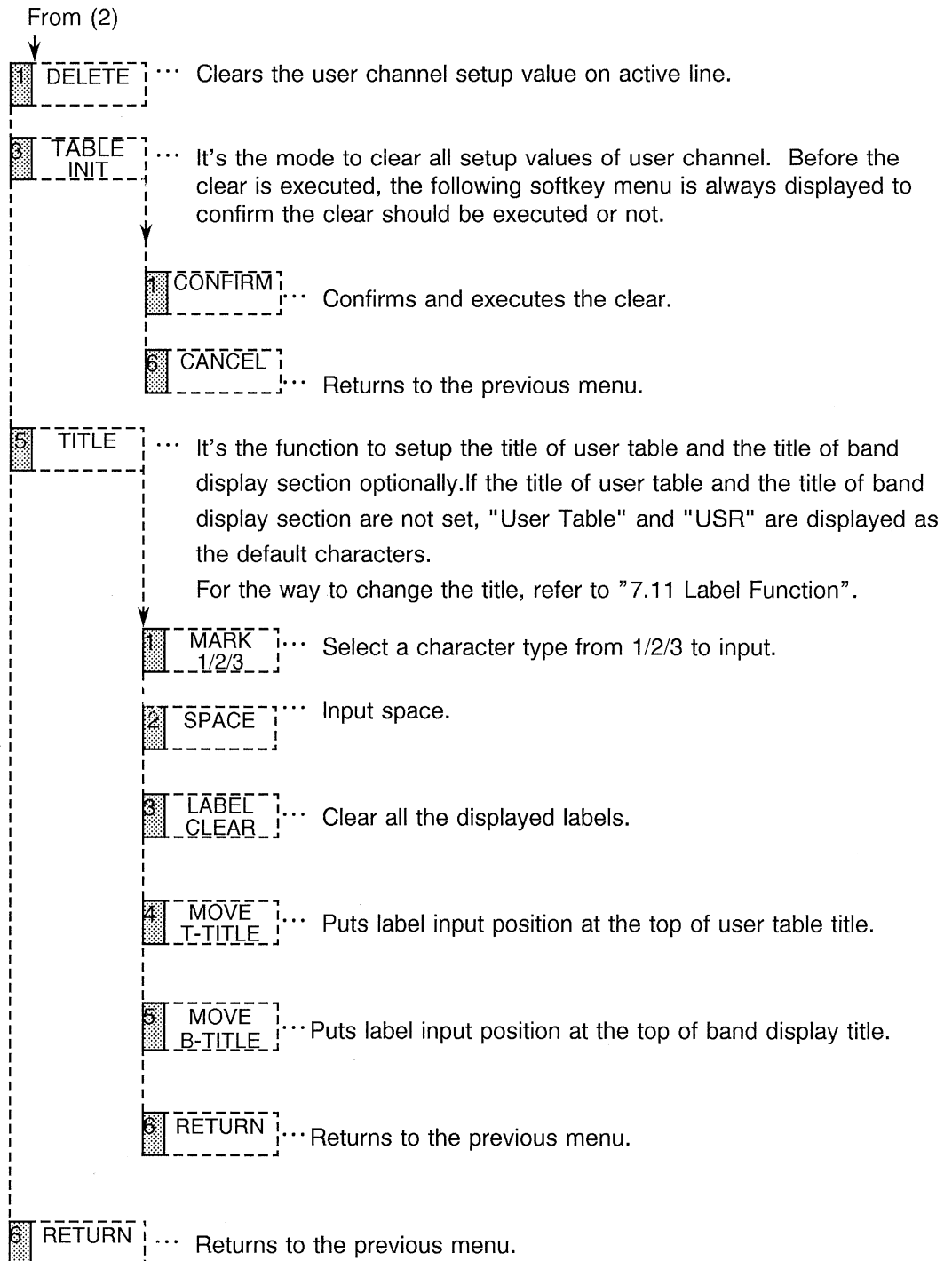

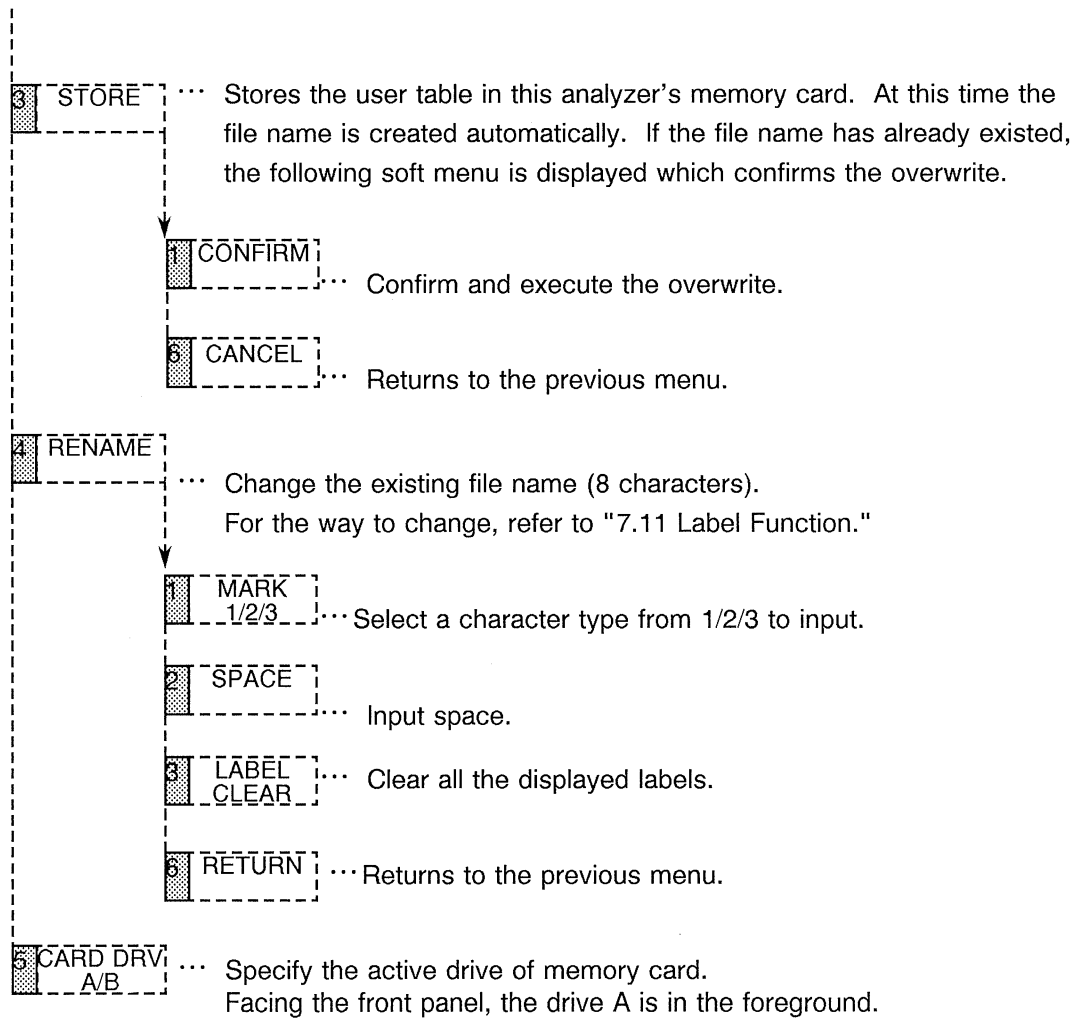

9.2 Channel Table Allocation (SHIFT Key + TV Key)

- Operation and explanation

This analyzer enables to allocate the country channel table which you want to use for each



band (VHF/UHF/CATV/BS/CS) by press  .

Fig. 9-9 shows the possible setup example.

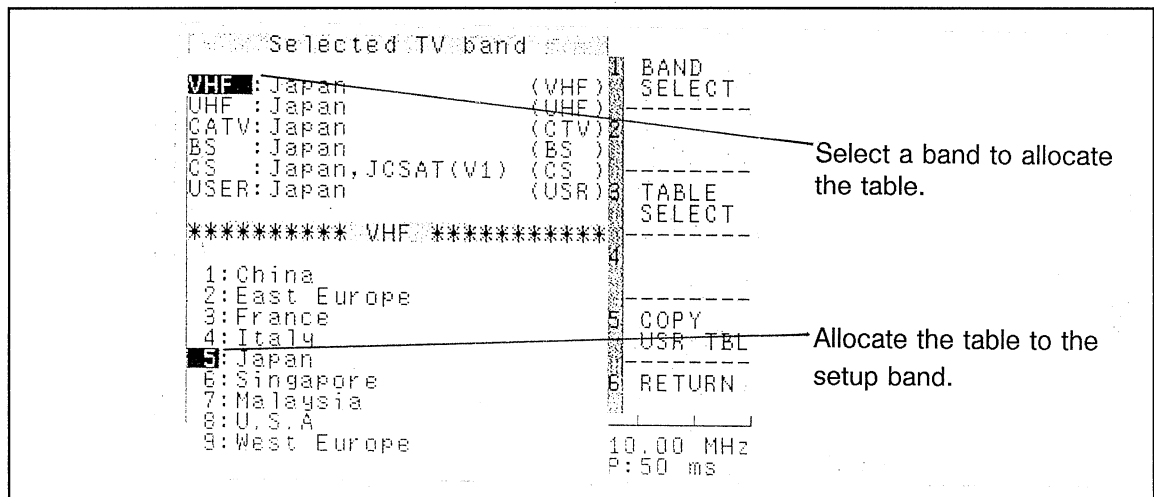
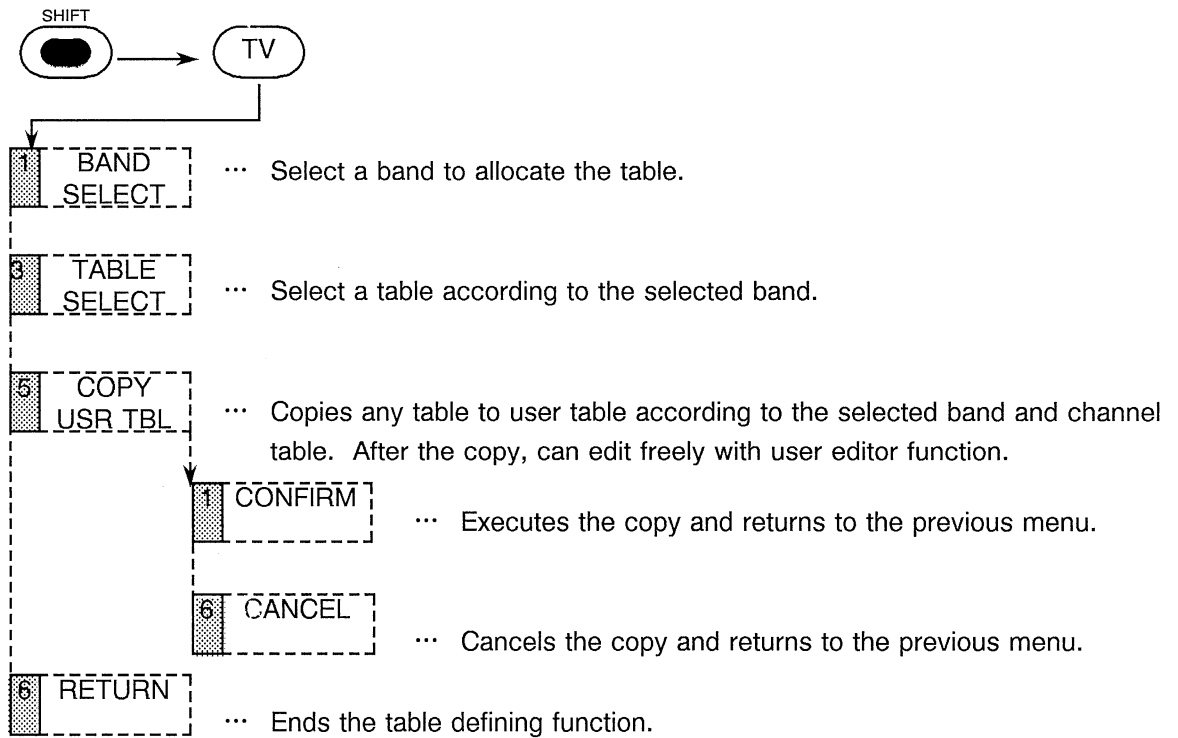

Figure 9-9 Setup example



9.3 Frequency Span Setup

Press SPAN in channel input mode, the menu for TV mode is displayed.

When TV key LED is lighting

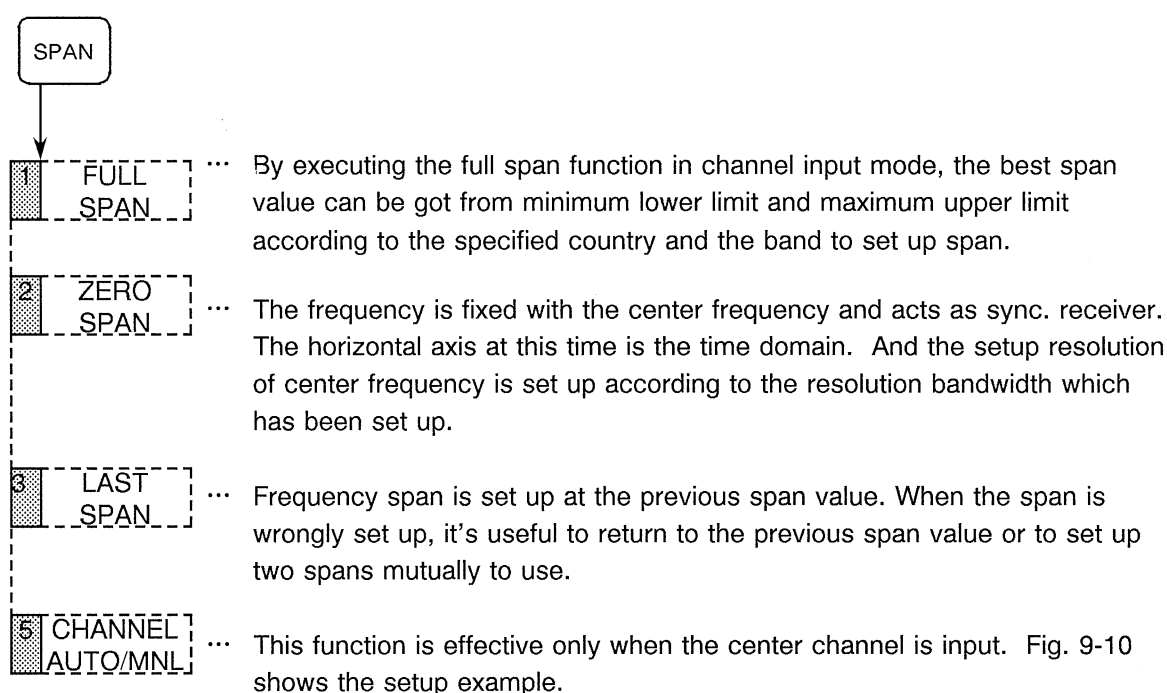

AUTO: When the center channel is input with this mode, sets up the frequency span with the best value of frequency bandwidth for 1CH, and sets the center of the specified channel bandwidth as the center frequency. When the selected band is in user mode, the best value of lower limit/upper limit is set up for the frequency span for 1CH.

(Note) Span may be modified. But each time the center CH is changed, span return to the best span for the channel.

MNL : When the center channel is input with this mode, sets the picture frequency as the center frequency and does not change the frequency span.

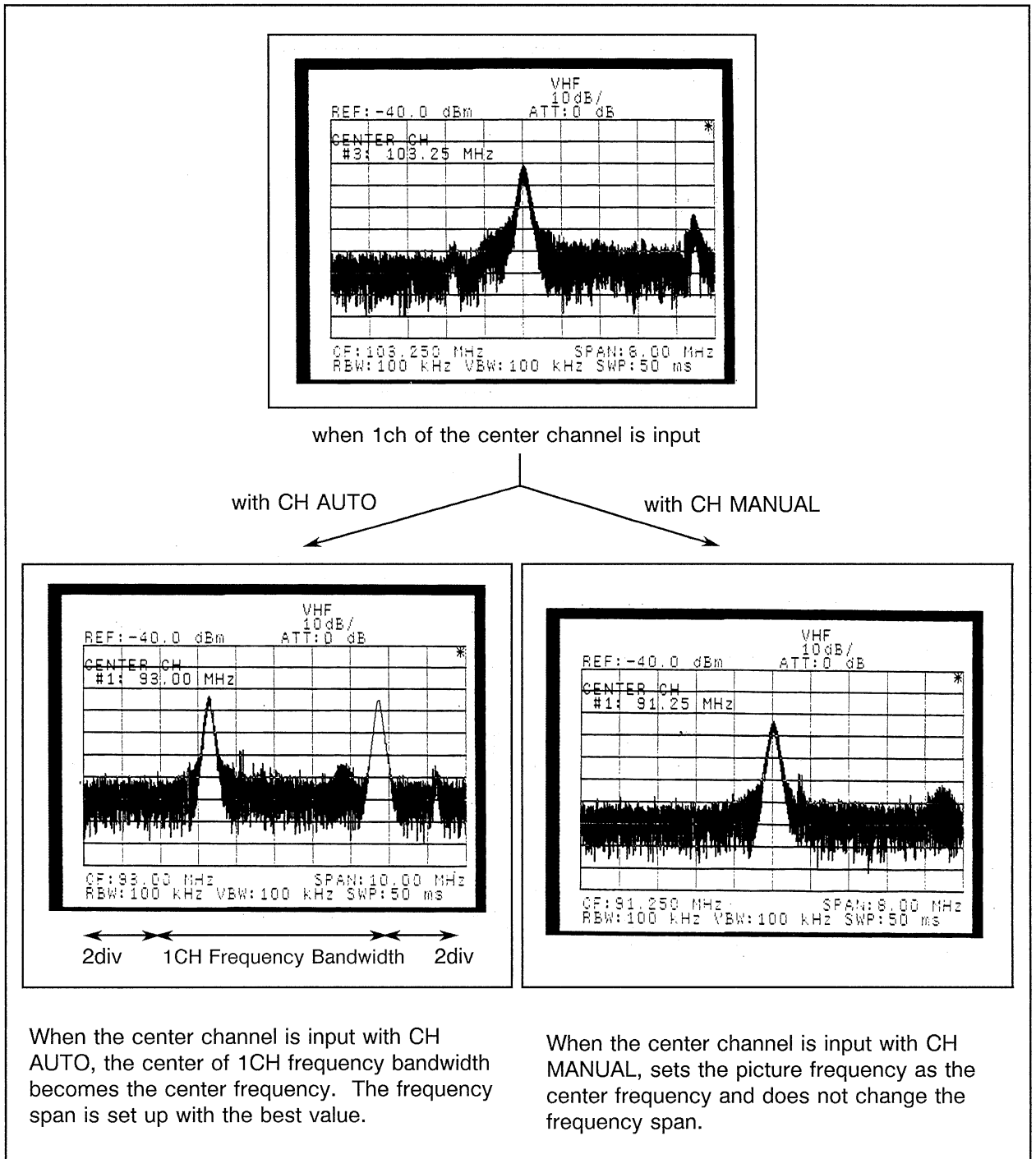

Figure 9-10 Center channel setup example (VHF in Japan)

9.4 Marker Channel number display

When it is in channel input mode, identifies TV channel number by marker frequency and displays the channel besides the marker frequency/the marker level. If the applicable channel number does not exist, "*" is displayed. At the time of monitor screen, the present marker channel number is displayed on the top left of the screen as Fig. 9-11 shows.

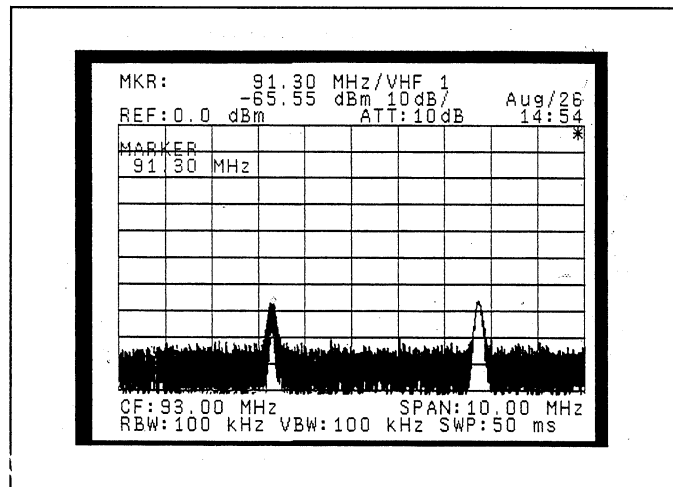

Figure 9-11 Channel number display screen

9.5 TV Channel Table

9.5.1 TV Standard Mode

The relationship between TV mode and scan line is shown in Table 9-1.

Table 9-1 TV mode and scan line number

TV mode	B	D	G	I	K	K1	L	M
Scan line number	625	625	625	625	625	625	625	525

Table 9-2 shows TV standard mode (TV mode) in each country.

Table 9-2 TV standard mode

Country	VHF	UHF
Japan	M/NTSC	M/NTSC
China	D/PAL	D/PAL
Malaysia	B/PAL	G/PAL
Singapore	B/PAL	---
U.S.A	M/NTSC	M/NTSC
Bulgaria	D/SECAM	K/SECAM
Czechoslovakia	D/SECAM	K/SECAM
Hungary	D/SECAM	K/SECAM
Poland	D/SECAM	K/SECAM
Rumania	D/PAL	K/PAL
Old Soviet Union	D/SECAM	K/SECAM
Austria	B/PAL	G/PAL
Denmark	B/PAL	G/PAL
Old East Germany	B/SECAM	G/SECAM
Finland	B/PAL	G/PAL
France	L/SECAM	L/SECAM
Greece	B/SECAM	G/SECAM
Holland	B/PAL	G/PAL
Italy	B/PAL	---
Spain	B/PAL	G/PAL
Sweden	B/PAL	G/PAL
Switzerland	B/PAL	G/PAL
Old West Germany	B/PAL	G/PAL

9.5.2 Channel Table Title by Band

The followings show the channel tables which can be used with channel assignment function.

(1) VHF

Table 9-3 Channel table of VHF

Country	Table title	Remarks
China	China	*1
East Europe	East Europe	
France	France	
Italy	Italy	
Japan	Japan	
Singapore	Singapore	*2
Malaysia	Malaysia	
U.S.A	U.S.A	
West Europe	West Europe	

(2) UHF

Table 9-4 Channel table of UHF

Country	Table title	Remarks
China	China	*1
East Europe	East Europe	
France	France	
Japan	Japan	
U.S.A	U.S.A	
West Europe	West Europe	*2

(Note) Countries corresponding to table *1:
Bulgaria, Czechoslovakia, Hungary, Poland, Rumania, and old Soviet Union.

Countries corresponding to table *2:
Austria, Denmark, Germany, Finland, Greece, Holland, Spain, Sweden and Switzerland.

(3) CATV

Table 9-5 Channel table of CATV

Country	Table title	Remarks
East Europe	East Europe	*1
France	France,CCETT	
France	France,TELECOM	
Japan	Japan	
Korea	Korea	
U.S.A	U.S.A	
West Europe	West Europe	*2

(Note) Countries corresponding to table *1:

Bulgaria, Czechoslovakia, Hungary, Poland, Rumania, and old Soviet Union.

Countries corresponding to table *2:

Austria, Denmark, Germany, Finland, Greece, Holland, Spain, Sweden and Switzerland.

(4) BS

Table 9-6 Channel table of BS

Country	Table title
Japan	Japan

(5) CS

Table 9-7 Channel table of CS (Japan)

Table title	Description
JCSAT(V:TYPE1)/(V1)	For JCSAT communication, local oscillation 11.3 GHz, vertically polarized waves
JCSAT(V:TYPE2)/(V2)	For JCSAT communication, local oscillation 10.873 GHz, vertically polarized waves
JCSAT(V:SOUND)/(VS)	For JCSAT broadcast, local oscillation 11.2 GHz, vertically polarized waves
JCSAT(H:TYPE1)/(H1)	For JCSAT communication, local oscillation 11.3GHz, horizontally polarized waves
JCSAT(H:TYPE2)/(H2)	For JCSAT communication, local oscillation 10.873 GHz, horizontally polarized waves
JCSAT(H:TV)/(HT)	For JCSAT broadcast, local oscillation 11.2 GHz, horizontally polarized waves
SCC(V:TYPE1)/(V1)	For SCC communication, local oscillation 11.3 GHz, vertically polarized waves
SCC(V:TYPE2)/(V2)	For SCC communication, local oscillation 10.99 GHz, vertically polarized waves
SCC(V:TV)/(VT)	For SCC broadcast, local oscillation 11.2 GHz, vertically polarized waves
SCC(H:TYPE1)/(H1)	For SCC communication, local oscillation 11.3 GHz, horizontally polarized waves
SCC(H:TYPE2)/(H2)	For SCC communication, local oscillation 10.99 GHz, horizontally polarized waves

9.5.3 Channel Table List by Country

(1) Japan

① VHF

Table 9-8 Channel table of VHF in Japan

Analyzer's channel	Channel	Frequency range (MHz)	Picture frequency (MHz)	Sound frequency (MHz)
1	1	90.00 to 96.00	91.25	95.75
2	2	96.00 to 102.00	97.25	101.75
3	3	102.00 to 108.00	103.25	107.75
4	4	170.00 to 176.00	171.25	175.75
5	5	176.00 to 182.00	177.25	181.75
6	6	182.00 to 188.00	183.25	187.75
7	7	188.00 to 194.00	189.25	193.75
8	8	192.00 to 198.00	193.25	197.75
9	9	198.00 to 204.00	199.25	203.75
10	10	204.00 to 210.00	205.25	209.75
11	11	210.00 to 216.00	211.25	215.75
12	12	216.00 to 222.00	217.25	221.75

② UHF

Table 9-9 Channel table of UHF in Japan

Analyzer's channel	Channel	Frequency range (MHz)	Picture frequency (MHz)	Sound frequency (MHz)
13	13	470.00 to 476.00	471.25	475.75
14	14	476.00 to 482.00	477.25	481.75
15	15	482.00 to 488.00	483.25	487.75
16	16	488.00 to 494.00	489.25	493.75
17	17	494.00 to 500.00	495.25	499.75
18	18	500.00 to 506.00	501.25	505.75
19	19	506.00 to 512.00	507.25	511.75
20	20	512.00 to 518.00	513.25	517.75
21	21	518.00 to 524.00	519.25	523.75
22	22	524.00 to 530.00	525.25	529.75
23	23	530.00 to 536.00	531.25	535.75
24	24	536.00 to 542.00	537.25	541.75
25	25	542.00 to 548.00	543.25	547.75

**SPECTRUM ANALYZER
OPERATION MANUAL**

9.5 TV Channel Table

(cont'd)

Analyzer's channel	Channel	Frequency range (MHz)	Picture frequency (MHz)	Sound frequency (MHz)
26	26	548.00 to 554.00	549.25	553.75
27	27	554.00 to 560.00	555.25	559.75
28	28	560.00 to 566.00	561.25	565.75
29	29	566.00 to 572.00	567.25	571.75
30	30	572.00 to 578.00	573.25	577.75
31	31	578.00 to 584.00	579.25	583.75
32	32	584.00 to 590.00	585.25	589.75
33	33	590.00 to 596.00	591.25	595.75
34	34	596.00 to 602.00	597.25	601.75
35	35	602.00 to 608.00	603.25	607.75
36	36	608.00 to 614.00	609.25	613.75
37	37	614.00 to 620.00	615.25	619.75
38	38	620.00 to 626.00	621.25	625.75
39	39	626.00 to 632.00	627.25	631.75
40	40	632.00 to 638.00	633.25	637.75
41	41	638.00 to 644.00	639.25	643.75
42	42	644.00 to 650.00	645.25	649.75
43	43	650.00 to 656.00	651.25	655.75
44	44	656.00 to 662.00	657.25	661.75
45	45	662.00 to 668.00	663.25	667.75
46	46	668.00 to 674.00	669.25	673.75
47	47	674.00 to 680.00	675.25	679.75
48	48	680.00 to 686.00	681.25	685.75
49	49	686.00 to 692.00	687.25	691.75
50	50	692.00 to 698.00	693.25	697.75
51	51	698.00 to 704.00	699.25	703.75
52	52	704.00 to 710.00	705.25	709.75
53	53	710.00 to 716.00	711.25	715.75
54	54	716.00 to 722.00	717.25	721.75
55	55	722.00 to 728.00	723.25	727.75
56	56	728.00 to 734.00	729.25	733.75
57	57	734.00 to 740.00	735.25	739.75
58	58	740.00 to 746.00	741.25	745.75
59	59	746.00 to 752.00	747.25	751.75
60	60	752.00 to 758.00	753.25	757.75
61	61	758.00 to 764.00	759.25	763.75
62	62	764.00 to 770.00	765.25	769.75

**SPECTRUM ANALYZER
OPERATION MANUAL**

9.5 TV Channel Table

③ CATV

Table 9-10 Channel table of CATV in Japan

Analyzer's channel	Channel	Frequency range (MHz)	Picture frequency (MHz)	Sound frequency (MHz)
1	1	90.00 to 96.00	91.25	95.75
2	2	96.00 to 102.00	97.25	101.75
3	3	102.00 to 108.00	103.25	107.75
13	C13	108.00 to 114.00	109.25	113.75
14	C14	114.00 to 120.00	115.25	119.75
15	C15	120.00 to 126.00	121.25	125.75
16	C16	126.00 to 132.00	127.25	131.75
17	C17	132.00 to 138.00	133.25	137.75
18	C18	138.00 to 144.00	139.25	143.75
19	C19	144.00 to 150.00	145.25	149.75
20	C20	150.00 to 156.00	151.25	155.75
21	C21	156.00 to 162.00	157.25	161.75
22	C22	164.00 to 170.00	165.25	169.75
4	4	170.00 to 176.00	171.25	175.75
5	5	176.00 to 182.00	177.25	181.75
6	6	182.00 to 188.00	183.25	187.75
7	7	188.00 to 194.00	189.25	193.75
8	8	192.00 to 198.00	193.25	197.75
9	9	198.00 to 204.00	199.25	203.75
10	10	204.00 to 210.00	205.25	209.75
11	11	210.00 to 216.00	211.25	215.75
12	12	216.00 to 222.00	217.25	221.75
23	C23	222.00 to 228.00	223.25	227.75
24	C24	230.00 to 236.00	231.25	235.75
25	C25	236.00 to 242.00	237.25	241.75
26	C26	242.00 to 248.00	243.25	247.75
27	C27	248.00 to 254.00	249.25	253.75
28	C28	252.00 to 258.00	253.25	257.75
29	C29	258.00 to 264.00	259.25	263.75
30	C30	264.00 to 270.00	265.25	269.75

**SPECTRUM ANALYZER
OPERATION MANUAL**

9.5 TV Channel Table

(cont'd)

Analyzer's channel	Channel	Frequency range (MHz)	Picture frequency (MHz)	Sound frequency (MHz)
31	C31	270.00 to 276.00	271.25	275.75
32	C32	276.00 to 282.00	277.25	281.75
33	C33	282.00 to 288.00	283.25	287.75
34	C34	288.00 to 294.00	289.25	293.75
35	C35	294.00 to 300.00	295.25	299.75
36	C36	300.00 to 306.00	301.25	305.75
37	C37	306.00 to 312.00	307.25	311.75
38	C38	312.00 to 318.00	313.25	317.75
39	C39	318.00 to 324.00	319.25	323.75
40	C40	324.00 to 330.00	325.25	329.75
41	C41	330.00 to 336.00	331.25	335.75
42	C42	336.00 to 342.00	337.25	341.75
43	C43	342.00 to 348.00	343.25	347.75
44	C44	348.00 to 354.00	349.25	353.75
45	C45	354.00 to 360.00	355.25	359.75
46	C46	360.00 to 366.00	361.25	365.75
47	C47	366.00 to 372.00	367.25	371.75
48	C48	372.00 to 378.00	373.25	377.75
49	C49	378.00 to 384.00	379.25	383.75
50	C50	384.00 to 390.00	385.25	389.75
51	C51	390.00 to 396.00	391.25	395.75
52	C52	396.00 to 402.00	397.25	401.75
53	C53	402.00 to 408.00	403.25	407.75
54	C54	408.00 to 414.00	409.25	413.75
55	C55	414.00 to 420.00	415.25	419.75
56	C56	420.00 to 426.00	421.25	425.75
57	C57	426.00 to 432.00	427.25	431.75
58	C58	432.00 to 438.00	433.25	437.75
59	C59	438.00 to 444.00	439.25	443.75
60	C60	444.00 to 450.00	445.25	449.75
61	C61	450.00 to 456.00	451.25	455.75
62	C62	456.00 to 462.00	457.25	461.75
63	C63	462.00 to 468.00	463.25	467.75

**SPECTRUM ANALYZER
OPERATION MANUAL**

9.5 TV Channel Table

④ BS

Table 9-11 Channel table of BS in Japan

Analyzer's channel	Channel	Frequency range (MHz)	Center frequency (MHz)
1	BS-1	1035.98 to 1062.98	1049.48
3	BS-3	1074.34 to 1101.34	1087.84
5	BS-5	1112.70 to 1139.70	1126.20
7	BS-7	1151.06 to 1178.06	1164.56
9	BS-9	1189.42 to 1216.42	1202.92
11	BS-11	1227.78 to 1254.78	1241.28
13	BS-13	1266.14 to 1293.14	1279.64
15	BS-15	1304.50 to 1331.50	1318.00

⑤ CS

(V:TYPE1) For JCSAT communication / local oscillation 11.3 GHz / vertically polarized waves

Table 9-12 Channel table of CS in Japan (V:TYPE1)

Analyzer's channel	Transponder No.	Frequency range (MHz)	Center frequency (MHz)
1	1	954.75 to 981.75	968.25
3	3	984.75 to 1011.75	998.25
5	5	1014.75 to 1041.75	1028.25
7	7	1044.75 to 1071.75	1058.25
9	9	1074.75 to 1101.75	1088.25
11	11	1104.75 to 1131.75	1118.25
13	13	1134.75 to 1161.75	1148.25
15	15	1164.75 to 1191.75	1178.25
17	17	1194.75 to 1221.75	1208.25
19	19	1224.75 to 1251.75	1238.25
21	21	1254.75 to 1281.75	1268.25
23	23	1284.75 to 1311.75	1298.25
25	25	1314.75 to 1341.75	1328.25
27	27	1344.75 to 1371.75	1358.25
29	29	1374.75 to 1401.75	1388.25
31	31	1404.75 to 1431.75	1418.25

**SPECTRUM ANALYZER
OPERATION MANUAL**

9.5 TV Channel Table

(V:TYPE2) For JCSAT communication / local oscillation 10.873 GHz / vertically polarized waves

Table 9-13 Channel table of CS in Japan (V:TYPE2)

Analyzer's channel	Transponder No.	Frequency range (MHz)	Center frequency (MHz)
1	1	1381.75 to 1408.75	1395.25
3	3	1411.75 to 1438.75	1425.25
5	5	1441.75 to 1468.75	1455.25
7	7	1471.75 to 1498.75	1485.25
9	9	1501.75 to 1528.75	1515.25
11	11	1531.75 to 1558.75	1545.25
13	13	1561.75 to 1588.75	1575.25
15	15	1591.75 to 1618.75	1605.25
17	17	1621.75 to 1648.75	1635.25
19	19	1651.75 to 1678.75	1665.25
21	21	1681.75 to 1708.75	1695.25
23	23	1711.75 to 1738.75	1725.25
25	25	1741.75 to 1768.75	1755.25
27	27	1771.75 to 1798.75	1785.25
29	29	1801.75 to 1828.75	1815.25
31	31	1831.75 to 1858.75	1845.25

(V:SOUND) For JCSAT broadcast / local oscillation 11.2 GHz / vertically polarized waves

Table 9-14 Channel table of CS in Japan (V:SOUND)

Analyzer's channel	Transponder No./ Channel	Frequency range (MHz)	Center frequency (MHz)
6	23/J-6	1384.75 to 1411.75	1398.25
8	25/J-8	1414.75 to 1441.75	1428.25

**SPECTRUM ANALYZER
OPERATION MANUAL**

9.5 TV Channel Table

(H:TYPE1) For JCSAT communication / local oscillation 11.3 GHz / horizontally polarized waves

Table 9-15 Channel table of CS in Japan (H:TYPE1)

Analyzer's channel	Transponder No.	Frequency range (MHz)	Center frequency (MHz)
2	2	969.75 to 996.75	983.25
4	4	999.75 to 1026.75	1013.25
6	6	1029.75 to 1056.75	1043.25
8	8	1059.75 to 1086.75	1073.25
10	10	1089.75 to 1116.75	1103.25
12	12	1119.75 to 1146.75	1133.25
14	14	1149.75 to 1176.75	1163.25
16	16	1179.75 to 1206.75	1193.25
18	18	1209.75 to 1236.75	1223.25
20	20	1239.75 to 1266.75	1253.25
22	22	1269.75 to 1296.75	1283.25
24	24	1299.75 to 1326.75	1313.25
26	26	1329.75 to 1356.75	1343.25
28	28	1359.75 to 1386.75	1373.25
30	30	1389.75 to 1416.75	1403.25
32	32	1419.75 to 1446.75	1433.25

**SPECTRUM ANALYZER
OPERATION MANUAL**

9.5 TV Channel Table

(H:TYPE2) For JCSAT communication / local oscillation 10.873 GHz / horizontally polarized waves

Table 9-16 Channel table of CS in Japan (H:TYPE2)

Analyzer's channel	Transponder No.	Frequency range (MHz)	Center frequency (MHz)
2	2	1396.75 to 1423.75	1410.25
4	4	1426.75 to 1453.75	1440.25
6	6	1456.75 to 1483.75	1470.25
8	8	1486.75 to 1513.75	1500.25
10	10	1516.75 to 1543.75	1530.25
12	12	1546.75 to 1573.75	1560.25
14	14	1576.75 to 1603.75	1590.25
16	16	1606.75 to 1633.75	1620.25
18	18	1636.75 to 1663.75	1650.25
20	20	1666.75 to 1693.75	1680.25
22	22	1696.75 to 1723.75	1710.25
24	24	1726.75 to 1753.75	1740.25
26	26	1756.75 to 1783.75	1770.25
28	28	1786.75 to 1813.75	1800.25
30	30	1816.75 to 1843.75	1830.25
32	32	1846.75 to 1873.75	1860.25

(H:TV) For JCSAT broadcast / local oscillation 11.2 GHz / horizontally polarized waves

Table 9-17 Channel table of CS in Japan (H:TV)

Analyzer's channel	Transponder No. / Channel	Frequency range (MHz)	Center frequency (MHz)
1	18/J-1	1309.75 to 1336.75	1323.25
3	20/J-3	1339.75 to 1366.75	1353.25
5	22/J-5	1369.75 to 1396.75	1383.25
7	24/J-7	1399.75 to 1426.75	1413.25
9	26/J-9	1429.75 to 1456.75	1443.25
11	28/J-11	1459.75 to 1486.75	1473.25
13	30/J-13	1489.75 to 1516.75	1503.25

**SPECTRUM ANALYZER
OPERATION MANUAL**

9.5 TV Channel Table

(SCC V:TYPE1) For SCC communication/ local oscillation 11.3GHz/ vertically polarized waves

Table 9-18 Channel table of CS in Japan (SCC V:TYPE1)

Analyzer's channel	Transponder No.	Frequency range (MHz)	Center frequency (MHz)
1	1	972.00 to 1008.00	990.00
2	2	1012.00 to 1048.00	1030.00
3	3	1052.00 to 1088.00	1070.00
4	4	1092.00 to 1128.00	1110.00
5	5	1132.00 to 1168.00	1150.00
6	6	1172.00 to 1208.00	1190.00
7	7	1212.00 to 1248.00	1230.00
8	8	1252.00 to 1288.00	1270.00
9	9	1292.00 to 1328.00	1310.00
10	10	1332.00 to 1368.00	1350.00
11	11	1372.00 to 1408.00	1390.00
12	12	1412.00 to 1448.00	1430.00

(SCC V:TYPE2) For SCC communication/ local oscillation 10.99GHz/ vertically polarized waves

Table 9-19 Channel table of CS in Japan (SCC V:TYPE2)

Analyzer's channel	Transponder No.	Frequency range (MHz)	Center frequency (MHz)
1	1	1282.00 to 1318.00	1300.00
2	2	1322.00 to 1358.00	1340.00
3	3	1362.00 to 1398.00	1380.00
4	4	1402.00 to 1438.00	1420.00
5	5	1442.00 to 1478.00	1460.00
6	6	1482.00 to 1518.00	1500.00
7	7	1522.00 to 1558.00	1540.00
8	8	1562.00 to 1598.00	1580.00
9	9	1602.00 to 1638.00	1620.00
10	10	1642.00 to 1678.00	1660.00
11	11	1682.00 to 1718.00	1700.00
12	12	1722.00 to 1758.00	1740.00

**SPECTRUM ANALYZER
OPERATION MANUAL**

9.5 TV Channel Table

(SCC V:TV) For SCC broadcast / local oscillation 11.2 GHz / vertically polarized waves

Table 9-20 Channel table of CS in Japan (SCC V:TV)

Analyzer's channel	Transponder No. / Channel	Frequency range (MHz)	Center frequency (MHz)
1	7/S-1	1312.00 to 1348.00	1330.00
3	8/S-3	1352.00 to 1388.00	1370.00
5	9/S-5	1392.00 to 1428.00	1410.00
7	10/S-7	1432.00 to 1468.00	1450.00
9	11/S-9	1472.00 to 1508.00	1490.00
11	12/S-11	1512.00 to 1548.00	1530.00

(SCC H:TYPE1) For SCC communication / local oscillation 11.3 GHz / horizontally polarized waves

Table 9-21 Channel table of CS in Japan (SCC H:TYPE1)

Analyzer's channel	Transponder No.	Frequency range (MHz)	Center frequency (MHz)
13	13	992.00 to 1028.00	1010.00
14	14	1032.00 to 1068.00	1050.00
15	15	1072.00 to 1108.00	1090.00
16	16	1112.00 to 1148.00	1130.00
17	17	1152.00 to 1188.00	1170.00
18	18	1192.00 to 1228.00	1210.00
19	19	1232.00 to 1268.00	1250.00
20	20	1272.00 to 1308.00	1290.00
21	21	1312.00 to 1348.00	1330.00
22	22	1352.00 to 1388.00	1370.00
23	23	1392.00 to 1428.00	1410.00

**SPECTRUM ANALYZER
OPERATION MANUAL**

9.5 TV Channel Table

(SCC H:TYPE2) For SCC communication / local oscillation 10.99 GHz / horizontally polarized waves

Table 9-22 Channel table of CS in Japan (SCC H:TYPE2)

Analyzer's channel	Transponder No.	Frequency range (MHz)	Center frequency (MHz)
13	13	1302.00 to 1338.00	1320.00
14	14	1342.00 to 1378.00	1360.00
15	15	1382.00 to 1418.00	1400.00
16	16	1422.00 to 1458.00	1440.00
17	17	1462.00 to 1498.00	1480.00
18	18	1502.00 to 1538.00	1520.00
19	19	1542.00 to 1578.00	1560.00
20	20	1582.00 to 1618.00	1600.00
21	21	1622.00 to 1658.00	1640.00
22	22	1662.00 to 1698.00	1680.00
23	23	1702.00 to 1738.00	1720.00

**SPECTRUM ANALYZER
OPERATION MANUAL**

9.5 TV Channel Table

(2) China

① VHF

Table 9-23 Channel table of VHF in China

Analyzer's channel	Channel	Frequency range (MHz)	Picture frequency (MHz)	Sound frequency (MHz)
1	1	48.50 to 56.50	49.75	56.25
2	2	56.50 to 64.50	57.75	64.25
3	3	64.50 to 72.50	65.75	72.25
4	4	76.00 to 84.00	77.25	83.75
5	5	84.00 to 92.00	85.25	91.75
6	6	167.00 to 175.00	168.25	174.75
7	7	175.00 to 183.00	176.25	182.75
8	8	183.00 to 191.00	184.25	190.75
9	9	191.00 to 199.00	192.25	198.75
10	10	199.00 to 207.00	200.25	206.75
11	11	207.00 to 215.00	208.25	214.75
12	12	215.00 to 223.00	216.25	222.75

② UHF

Table 9-24 Channel table of UHF in China

Analyzer's channel	Channel	Frequency range (MHz)	Picture frequency (MHz)	Sound frequency (MHz)
13	13	470.00 to 478.00	471.25	477.75
14	14	478.00 to 486.00	479.25	485.75
15	15	486.00 to 494.00	487.25	493.75
16	16	494.00 to 502.00	495.25	501.75
17	17	502.00 to 510.00	503.25	509.75
18	18	510.00 to 518.00	511.25	517.75
19	19	518.00 to 526.00	519.25	525.75
20	20	526.00 to 534.00	527.25	533.75
21	21	534.00 to 542.00	535.25	541.75
22	22	542.00 to 550.00	543.25	549.75
23	23	550.00 to 558.00	551.25	557.75
24	24	558.00 to 566.00	559.25	565.75
25	25	606.00 to 614.00	607.25	613.75

**SPECTRUM ANALYZER
OPERATION MANUAL**

9.5 TV Channel Table

(cont'd)

Analyzer's channel	Channel	Frequency range (MHz)	Picture frequency (MHz)	Sound frequency (MHz)
26	26	614.00 to 622.00	615.25	621.75
27	27	622.00 to 630.00	623.25	629.75
28	28	630.00 to 638.00	631.25	637.75
29	29	638.00 to 646.00	639.25	645.75
30	30	646.00 to 654.00	647.25	653.75
31	31	654.00 to 662.00	655.25	661.75
32	32	662.00 to 670.00	663.25	669.75
33	33	670.00 to 678.00	671.25	677.75
34	34	678.00 to 686.00	679.25	685.75
35	35	686.00 to 694.00	687.25	693.75
36	36	694.00 to 702.00	695.25	701.75
37	37	702.00 to 710.00	703.25	709.75
38	38	710.00 to 718.00	711.25	717.75
39	39	718.00 to 726.00	719.25	725.75
40	40	726.00 to 734.00	727.25	733.75
41	41	734.00 to 742.00	735.25	741.75
42	42	742.00 to 750.00	743.25	749.72
43	43	750.00 to 758.00	751.25	757.75
44	44	758.00 to 766.00	759.25	765.75
45	45	766.00 to 774.00	767.25	773.75
46	46	774.00 to 782.00	775.25	781.75
47	47	782.00 to 790.00	783.25	789.75
48	48	790.00 to 798.00	791.25	797.75
49	49	798.00 to 806.00	799.25	805.75
50	50	806.00 to 814.00	807.25	813.75
51	51	814.00 to 822.00	815.25	821.75
52	52	822.00 to 830.00	823.25	829.75
53	53	830.00 to 838.00	831.25	837.75
54	54	838.00 to 846.00	839.25	845.75
55	55	846.00 to 854.00	847.25	853.75
56	56	854.00 to 862.00	855.25	861.75
57	57	862.00 to 870.00	863.25	869.75

(3) East Europe

① VHF

Table 9-25 Channel table of VHF in east Europe

Analyzer's channel	Channel	Frequency range (MHz)	Picture frequency (MHz)	Sound frequency (MHz)
1	1	48.50 to 56.50	49.75	56.25
2	2	58.00 to 66.00	59.25	65.75
3	3	76.00 to 84.00	77.25	83.75
4	4	84.00 to 92.00	85.25	91.75
5	5	92.00 to 100.00	93.25	99.75
6	6	174.00 to 182.00	175.25	181.75
7	7	182.00 to 190.00	183.25	189.75
8	8	190.00 to 198.00	191.25	197.75
9	9	198.00 to 206.00	199.25	205.75
10	10	206.00 to 214.00	207.25	213.75
11	11	214.00 to 222.00	215.25	221.75
12	12	222.00 to 230.00	223.25	229.75

② UHF

Table 9-26 Channel table of UHF in east Europe

Analyzer's channel	Channel	Frequency range (MHz)	Picture frequency (MHz)	Sound frequency (MHz)
21	21	470.00 to 478.00	471.25	477.75
22	22	478.00 to 486.00	479.25	485.75
23	23	486.00 to 494.00	487.25	493.75
24	24	494.00 to 502.00	495.25	501.75
25	25	502.00 to 510.00	503.25	509.75
26	26	510.00 to 518.00	511.25	517.75
27	27	518.00 to 526.00	519.25	525.75
28	28	526.00 to 534.00	527.25	533.75
29	29	534.00 to 542.00	535.25	541.75
30	30	542.00 to 550.00	543.25	549.75
31	31	550.00 to 558.00	551.25	557.75
32	32	558.00 to 566.00	559.25	565.75
33	33	566.00 to 574.00	567.25	573.75
34	34	574.00 to 582.00	575.25	581.75

**SPECTRUM ANALYZER
OPERATION MANUAL**

9.5 TV Channel Table

(cont'd)

Analyzer's channel	Channel	Frequency range (MHz)	Picture frequency (MHz)	Sound frequency (MHz)
35	35	582.00 to 590.00	583.25	589.75
36	36	590.00 to 598.00	591.25	597.75
37	37	598.00 to 606.00	599.25	605.75
38	38	606.00 to 614.00	607.25	613.75
39	39	614.00 to 622.00	615.25	621.75
40	40	622.00 to 630.00	623.25	629.75
41	41	630.00 to 638.00	631.25	637.75
42	42	638.00 to 646.00	639.25	645.75
43	43	646.00 to 654.00	647.25	653.75
44	44	654.00 to 662.00	655.25	661.75
45	45	662.00 to 670.00	663.25	669.75
46	46	670.00 to 678.00	671.25	677.75
47	47	678.00 to 686.00	679.25	685.75
48	48	686.00 to 694.00	687.25	693.75
49	49	694.00 to 702.00	695.25	701.75
50	50	702.00 to 710.00	703.25	709.75
51	51	710.00 to 718.00	711.25	717.75
52	52	718.00 to 726.00	719.25	725.75
53	53	726.00 to 734.00	727.25	733.75
54	54	734.00 to 742.00	735.25	741.75
55	55	742.00 to 750.00	743.25	749.75
56	56	750.00 to 758.00	751.25	757.75
57	57	758.00 to 766.00	759.25	765.75
58	58	766.00 to 774.00	767.25	773.75
59	59	774.00 to 782.00	775.25	781.75
60	60	782.00 to 790.00	783.25	789.75
61	61	790.00 to 798.00	791.25	797.75
62	62	798.00 to 806.00	799.25	805.75
63	63	806.00 to 814.00	807.25	813.75
64	64	814.00 to 822.00	815.25	821.75
65	65	822.00 to 830.00	823.25	829.75
66	66	830.00 to 838.00	831.25	837.75
67	67	838.00 to 846.00	839.25	845.75
68	68	846.00 to 854.00	847.25	853.75
69	69	854.00 to 862.00	855.25	861.75

③ CATV

Table 9-27 Channel table of CATV in east Europe

Analyzer's channel	Channel	Frequency range (MHz)	Picture frequency (MHz)	Sound frequency (MHz)
81	81	102.00 to 110.00	103.25	109.75
82	82	110.00 to 118.00	111.25	117.75
83	83	118.00 to 126.00	119.25	125.75
84	84	126.00 to 134.00	127.25	133.75
85	85	134.00 to 142.00	135.25	141.75
86	86	142.00 to 150.00	143.25	149.75
87	87	150.00 to 158.00	151.25	157.75
88	88	158.00 to 166.00	159.25	165.75
89	89	166.00 to 174.00	167.25	173.75
90	90	230.00 to 238.00	231.25	237.75
91	91	238.00 to 246.00	239.25	245.75
92	92	246.00 to 254.00	247.25	253.75
93	93	254.00 to 262.00	255.25	261.75
94	94	262.00 to 270.00	263.25	269.75
95	95	270.00 to 278.00	271.25	277.75
96	96	278.00 to 286.00	279.25	285.75
97	97	286.00 to 294.00	287.25	293.75
98	98	294.00 to 302.00	295.25	301.75
99	99	302.00 to 310.00	303.25	309.75

**SPECTRUM ANALYZER
OPERATION MANUAL**

9.5 TV Channel Table

(4) France

① VHF

Table 9-28 Channel table of VHF in France

Analyzer's channel	Channel	Frequency range (MHz)	Picture frequency (MHz)	Sound frequency (MHz)
2	2	49.00 to 57.00	55.75	49.25
3	3	53.75 to 61.75	60.50	54.00
4	4	57.00 to 65.00	63.75	57.25
5	5	174.75 to 182.75	176.00	182.50
6	6	182.75 to 190.75	184.00	190.50
7	7	190.75 to 198.75	192.00	198.50
8	8	198.75 to 206.75	200.00	206.50
9	9	206.75 to 214.75	208.00	214.50
10	10	214.75 to 222.75	216.00	222.50

② UHF

Table 9-29 Channel table of UHF in France

Analyzer's channel	Channel	Frequency range (MHz)	Picture frequency (MHz)	Sound frequency (MHz)
21	21	470.00 to 478.00	471.25	477.75
22	22	478.00 to 486.00	479.25	485.75
23	23	486.00 to 494.00	487.25	493.75
24	24	494.00 to 502.00	495.25	501.75
25	25	502.00 to 510.00	503.25	509.75
26	26	510.00 to 518.00	511.25	517.75
27	27	518.00 to 526.00	519.25	525.75
28	28	526.00 to 534.00	527.25	533.75
29	29	534.00 to 542.00	535.25	541.75
30	30	542.00 to 550.00	543.25	549.75
31	31	550.00 to 558.00	551.25	557.75
32	32	558.00 to 566.00	559.25	565.75
33	33	566.00 to 574.00	567.25	573.75
34	34	574.00 to 582.00	575.25	581.75
35	35	582.00 to 590.00	583.25	589.75
36	36	590.00 to 598.00	591.25	597.75
37	37	598.00 to 606.00	599.25	605.75
38	38	606.00 to 614.00	607.25	613.75
39	39	614.00 to 622.00	615.25	621.75

**SPECTRUM ANALYZER
OPERATION MANUAL**

9.5 TV Channel Table

(cont'd)

Analyzer's channel	Channel	Frequency range (MHz)	Picture frequency (MHz)	Sound frequency (MHz)
40	40	622.00 to 630.00	623.25	629.75
41	41	630.00 to 638.00	631.25	637.75
42	42	638.00 to 646.00	639.25	645.75
43	43	646.00 to 654.00	647.25	653.75
44	44	654.00 to 662.00	655.25	661.75
45	45	662.00 to 670.00	663.25	669.75
46	46	670.00 to 678.00	671.25	677.75
47	47	678.00 to 686.00	679.25	685.75
48	48	686.00 to 694.00	687.25	693.75
49	49	694.00 to 702.00	695.25	701.75
50	50	702.00 to 710.00	703.25	709.75
51	51	710.00 to 718.00	711.25	717.75
52	52	718.00 to 726.00	719.25	725.75
53	53	726.00 to 734.00	727.25	733.75
54	54	734.00 to 742.00	735.25	741.75
55	55	742.00 to 750.00	743.25	749.72
56	56	750.00 to 758.00	751.25	757.75
57	57	758.00 to 766.00	759.25	765.75
58	58	766.00 to 774.00	767.25	773.75
59	59	774.00 to 782.00	775.25	781.75
60	60	782.00 to 790.00	783.25	789.75
61	61	790.00 to 798.00	791.25	797.75
62	62	798.00 to 806.00	799.25	805.75
63	63	806.00 to 814.00	807.25	813.75
64	64	814.00 to 822.00	815.25	821.75
65	65	822.00 to 830.00	823.25	829.75
66	66	830.00 to 838.00	831.25	837.75
67	67	838.00 to 846.00	839.25	845.75
68	68	846.00 to 854.00	847.25	853.75
69	69	854.00 to 862.00	855.25	861.75

③ CATV

Table 9-30 Channel table of CATV (CCEET) in France

Analyzer's channel	Channel	Frequency range (MHz)	Picture frequency (MHz)	Sound frequency (MHz)
2	B	115.50 to 127.50	116.75	123.25
3	C	127.50 to 139.50	128.75	135.25
4	D	139.50 to 151.50	140.75	147.25
5	E	151.50 to 163.50	152.75	159.25
6	F	163.50 to 175.50	164.75	171.25
7	G	175.50 to 187.50	176.75	183.25
8	H	187.50 to 199.50	188.75	195.25
9	I	199.50 to 211.50	200.75	207.25
10	J	211.50 to 223.50	212.75	219.25
11	K	223.50 to 235.50	224.75	231.25
12	L	235.50 to 247.50	236.75	243.25
13	M	247.50 to 259.50	248.75	255.25
14	N	259.50 to 271.50	260.75	267.25
15	O	271.50 to 283.50	272.75	269.25
16	P	283.50 to 295.50	284.75	291.25
17	Q	295.50 to 307.50	296.75	303.25

**SPECTRUM ANALYZER
OPERATION MANUAL**

9.5 TV Channel Table

Table 9-31 Channel table of CATV (TETECOM) in France

Analyzer's channel	Channel	Frequency range (MHz)	Picture frequency (MHz)	Sound frequency (MHz)
4	S4	118.75 to 126.75	120.00	126.50
5	S5	126.75 to 134.75	128.00	134.50
6	S6	134.75 to 142.75	136.00	142.50
7	S7	142.75 to 150.75	144.00	150.50
8	S8	150.75 to 158.75	152.00	158.50
9	S9	158.75 to 166.75	160.00	166.50
10	S10	166.75 to 174.75	168.00	174.50
11	S11	222.75 to 230.75	224.00	230.50
12	S12	230.75 to 238.75	232.00	238.50
13	S13	238.75 to 246.75	240.00	246.50
14	S14	246.75 to 254.75	248.00	254.50
15	S15	254.75 to 262.75	256.00	262.50
16	S16	262.75 to 270.75	264.00	270.50
17	S17	270.75 to 278.75	272.00	278.50
18	S18	278.75 to 286.75	280.00	286.50
19	S19	286.75 to 294.75	288.00	294.50
20	S20	294.75 to 302.75	296.00	302.50
21	F21	302.00 to 314.00	303.25	309.50
22	F22	314.00 to 326.00	315.25	321.75
23	F23	326.00 to 338.00	327.25	333.75
24	F24	338.00 to 350.00	339.25	345.75
25	F25	350.00 to 362.00	351.25	357.75
26	F26	362.00 to 374.00	363.25	369.75
27	F27	374.00 to 386.00	375.25	381.75
28	F28	386.00 to 398.00	387.25	393.75
29	F29	398.00 to 410.00	399.25	405.75
30	F30	410.00 to 422.00	411.25	417.75
31	F31	422.00 to 434.00	423.25	429.75
32	F32	434.00 to 446.00	435.25	441.75
33	F33	446.00 to 458.00	447.25	453.75
34	F34	458.00 to 470.00	459.25	465.75

**SPECTRUM ANALYZER
OPERATION MANUAL**

9.5 TV Channel Table

(5) Italy

① VHF

Table 9-32 Channel table of VHF in Italy

Analyzer's channel	Channel	Frequency range (MHz)	Picture frequency (MHz)	Sound frequency (MHz)
1	A	52.50 to 59.50	53.75	59.25
2	B	61.00 to 68.00	62.25	67.75
3	C	81.00 to 88.00	82.25	87.75
4	D	174.00 to 181.00	175.25	180.75
5	E	182.50 to 189.50	183.75	189.25
6	F	191.00 to 198.00	192.25	197.75
7	G	200.00 to 207.00	201.25	206.75
8	H	209.00 to 216.00	210.25	215.75
9	H1	216.00 to 223.00	217.25	222.75
10	H2	223.00 to 230.00	224.25	229.75

**SPECTRUM ANALYZER
OPERATION MANUAL**

9.5 TV Channel Table

(6) Korea

① CATV

Table 9-33 Channel table of CATV in Korea

Analyzer's channel	Channel	Frequency range (MHz)	Picture frequency (MHz)	Sound frequency (MHz)
2	2	54.00 to 60.00	55.25	59.25
3	3	60.00 to 66.00	61.25	65.75
4	4	66.00 to 72.00	67.25	71.75
5	5	76.00 to 82.00	77.25	81.75
6	6	82.00 to 88.00	83.25	87.75
14	14	120.00 to 126.00	121.25	125.75
15	15	126.00 to 132.00	127.25	131.75
16	16	132.00 to 138.00	133.25	137.75
17	17	138.00 to 144.00	139.25	143.75
18	18	144.00 to 150.00	145.25	149.75
19	19	150.00 to 156.00	151.25	155.75
20	20	156.00 to 162.00	157.25	161.75
21	21	162.00 to 168.00	163.25	167.75
22	22	168.00 to 174.00	169.25	173.75
7	7	174.00 to 180.00	175.25	179.75
8	8	180.00 to 186.00	181.25	185.75
9	9	186.00 to 192.00	187.25	191.75
10	10	192.00 to 198.00	193.25	197.75
11	11	198.00 to 204.00	199.25	203.75
12	12	204.00 to 210.00	205.25	209.75
13	13	210.00 to 216.00	211.25	215.75
23	23	216.00 to 222.00	217.25	221.75
24	24	222.00 to 228.00	223.25	227.75
25	25	228.00 to 234.00	229.25	233.75
26	26	234.00 to 240.00	235.25	239.75
27	27	240.00 to 246.00	241.25	245.75
28	28	246.00 to 252.00	247.25	251.75
29	29	252.00 to 258.00	253.25	257.75
30	30	258.00 to 264.00	259.25	263.75
31	31	264.00 to 270.00	265.25	269.75
32	32	270.00 to 276.00	271.25	275.75
33	33	276.00 to 282.00	277.25	281.75
34	34	282.00 to 288.00	283.25	287.75
35	35	288.00 to 294.00	289.25	293.75
36	36	294.00 to 300.00	295.25	299.75
37	37	300.00 to 306.00	301.25	305.75
38	38	306.00 to 312.00	307.25	311.75

**SPECTRUM ANALYZER
OPERATION MANUAL**

9.5 TV Channel Table

(cont'd)

Analyzer's channel	Channel	Frequency range (MHz)	Picture frequency (MHz)	Sound frequency (MHz)
39	39	312.00 to 318.00	313.25	317.75
40	40	318.00 to 324.00	319.25	323.75
41	41	324.00 to 330.00	325.25	329.75
42	42	330.00 to 336.00	331.25	335.75
43	43	336.00 to 342.00	337.25	341.75
44	44	342.00 to 348.00	343.25	347.75
45	45	348.00 to 354.00	349.25	353.75
46	46	354.00 to 360.00	355.25	359.75
47	47	360.00 to 366.00	361.25	365.75
48	48	366.00 to 372.00	367.25	371.75
49	49	372.00 to 378.00	373.25	377.75
50	50	378.00 to 384.00	379.25	383.75
51	51	384.00 to 390.00	385.25	389.75
52	52	390.00 to 396.00	391.25	395.75
53	53	396.00 to 402.00	397.25	401.75
54	54	402.00 to 408.00	403.25	407.75
55	55	408.00 to 414.00	409.25	413.75
56	56	414.00 to 420.00	415.25	419.75
57	57	420.00 to 426.00	421.25	425.75
58	58	426.00 to 432.00	427.25	431.75
59	59	432.00 to 438.00	433.25	437.75
60	60	438.00 to 444.00	439.25	443.75
61	61	444.00 to 450.00	445.25	449.75

**SPECTRUM ANALYZER
OPERATION MANUAL**

9.5 TV Channel Table

(7) Singapore

① VHF

Table 9-34 Channel table of VHF in Singapore

Analyzer's channel	Channel	Frequency range (MHz)	Picture frequency (MHz)	Sound frequency (MHz)
5	5	174.00 to 181.00	175.25	180.75
8	8	195.00 to 202.00	196.25	201.75
12	12	223.00 to 230.00	224.25	229.75

(8) Malaysia

① VHF

Table 9-35 Channel table of VHF in Malaysia

Analyzer's channel	Channel	Frequency range (MHz)	Picture frequency (MHz)	Sound frequency (MHz)
1	1	54.00 to 61.00	55.25	60.75
2	2	209.00 to 216.00	210.25	215.75
3	3	510.00 to 518.00	511.25	516.75

(9) U.S.A

① VHF

Table 9-36 Channel table of VHF in U.S.A

Analyzer's channel	Channel	Frequency range (MHz)	Picture frequency (MHz)	Sound frequency (MHz)
2	2	54.00 to 60.00	55.25	59.75
3	3	60.00 to 66.00	61.25	65.75
4	4	66.00 to 72.00	67.25	71.75
5	5	76.00 to 82.00	77.25	81.75
6	6	82.00 to 88.00	83.25	87.75
7	7	174.00 to 180.00	175.25	179.75
8	8	180.00 to 186.00	181.25	185.75
9	9	186.00 to 192.00	187.25	191.75
10	10	192.00 to 198.00	193.25	197.75
11	11	198.00 to 204.00	199.25	203.75
12	12	204.00 to 210.00	205.25	209.75
13	13	210.00 to 216.00	211.25	215.75

**SPECTRUM ANALYZER
OPERATION MANUAL**

9.5 TV Channel Table

② UHF

Table 9-37 Channel table of UHF in U.S.A

Analyzer's channel	Channel	Frequency range (MHz)	Picture frequency (MHz)	Sound frequency (MHz)
14	14	470.00 to 476.00	471.25	475.75
15	15	476.00 to 482.00	477.25	481.75
16	16	482.00 to 488.00	483.25	487.75
17	17	488.00 to 494.00	489.25	493.75
18	18	494.00 to 500.00	495.25	499.75
19	19	500.00 to 506.00	501.25	505.75
20	20	506.00 to 512.00	507.25	511.75
21	21	512.00 to 518.00	513.25	517.75
22	22	518.00 to 524.00	519.25	523.75
23	23	524.00 to 530.00	525.25	529.75
24	24	530.00 to 536.00	531.25	535.75
25	25	536.00 to 542.00	537.25	541.75
26	26	542.00 to 548.00	543.25	547.75
27	27	548.00 to 554.00	549.25	553.75
28	28	554.00 to 560.00	555.25	559.75
29	29	560.00 to 566.00	561.25	565.75
30	30	566.00 to 572.00	567.25	571.75
31	31	572.00 to 578.00	573.25	577.75
32	32	578.00 to 584.00	579.25	583.75
33	33	584.00 to 590.00	585.25	589.75
34	34	590.00 to 596.00	591.25	595.75
35	35	596.00 to 602.00	597.25	601.75
36	36	602.00 to 608.00	603.25	607.75
37	37	608.00 to 614.00	609.25	613.75
38	38	614.00 to 620.00	615.25	619.75
39	39	620.00 to 626.00	621.25	625.75
40	40	626.00 to 632.00	627.25	631.75
41	41	632.00 to 638.00	633.25	637.75
42	42	638.00 to 644.00	639.25	643.75
43	43	644.00 to 650.00	645.25	649.75
44	44	650.00 to 656.00	651.25	655.75
45	45	656.00 to 662.00	657.25	661.75
46	46	662.00 to 668.00	663.25	667.75
47	47	668.00 to 674.00	669.25	673.75
48	48	674.00 to 680.00	675.25	679.75
49	49	680.00 to 686.00	681.25	685.75
50	50	686.00 to 692.00	687.25	691.75

**SPECTRUM ANALYZER
OPERATION MANUAL**

9.5 TV Channel Table

(cont'd)

Analyzer's channel	Channel	Frequency range (MHz)	Picture frequency (MHz)	Sound frequency (MHz)
51	51	692.00 to 698.00	693.25	697.75
52	52	698.00 to 704.00	699.25	703.75
53	53	704.00 to 710.00	705.25	709.75
54	54	710.00 to 716.00	711.25	715.75
55	55	716.00 to 722.00	717.25	721.75
56	56	722.00 to 728.00	723.25	727.75
57	57	728.00 to 734.00	729.25	733.75
58	58	734.00 to 740.00	735.25	739.75
59	59	740.00 to 746.00	741.25	745.75
60	60	746.00 to 752.00	747.25	751.75
61	61	752.00 to 758.00	753.25	757.75
62	62	758.00 to 764.00	759.25	763.75
63	63	764.00 to 770.00	765.25	769.75
64	64	770.00 to 776.00	771.25	775.75
65	65	776.00 to 782.00	777.25	781.75
66	66	782.00 to 788.00	783.25	787.75
67	67	788.00 to 794.00	789.25	793.75
68	68	794.00 to 800.00	795.25	799.75
69	69	800.00 to 806.00	801.25	805.75
70	70	806.00 to 812.00	807.25	811.75
71	71	812.00 to 818.00	813.25	817.75
72	72	818.00 to 824.00	819.25	823.75
73	73	824.00 to 830.00	825.25	829.75
74	74	830.00 to 836.00	831.25	835.75
75	75	836.00 to 842.00	837.25	841.75
76	76	842.00 to 848.00	843.25	847.75
77	77	848.00 to 854.00	849.25	853.75
78	78	854.00 to 860.00	855.25	859.75
79	79	860.00 to 866.00	861.25	865.75
80	80	866.00 to 872.00	867.25	871.75
81	81	872.00 to 878.00	873.25	877.75
82	82	878.00 to 884.00	879.25	883.75
83	83	884.00 to 890.00	885.25	889.75

**SPECTRUM ANALYZER
OPERATION MANUAL**

9.5 TV Channel Table

③ CATV

Table 9-38 Channel table of CATV in U.S.A

Analyzer's channel	Channel	Frequency range (MHz)	Picture frequency (MHz)	Sound frequency (MHz)
2	2/2	54.00 to 60.00	55.25	59.75
3	3/3	60.00 to 66.00	61.25	65.75
4	4/4	66.00 to 72.00	67.25	71.75
1	5A/1	72.00 to 78.00	73.25	77.75
5	5/5	76.00 to 82.00	77.25	81.75
6	6/6	82.00 to 88.00	83.25	87.75
95	A-5/95	90.00 to 96.00	91.25	95.75
96	A-4/96	96.00 to 102.00	97.25	101.75
97	A-3/97	102.00 to 108.00	103.25	107.75
98	A-2/98	108.00 to 114.00	109.25	113.75
99	A-1/99	114.00 to 120.00	115.25	119.75
14	A/14	120.00 to 126.00	121.25	125.75
15	B/15	126.00 to 132.00	127.25	131.75
16	C/16	132.00 to 138.00	133.25	137.75
17	D/17	138.00 to 144.00	139.25	143.75
18	E/18	144.00 to 150.00	145.25	149.75
19	F/19	150.00 to 156.00	151.25	155.75
20	G/20	156.00 to 162.00	157.25	161.75
21	H/21	162.00 to 168.00	163.25	167.75
22	I/22	168.00 to 174.00	169.25	173.75
7	7/7	174.00 to 180.00	175.25	179.75
8	8/8	180.00 to 186.00	181.25	185.75
9	9/9	186.00 to 192.00	187.25	191.75
10	10/10	192.00 to 198.00	193.25	197.75
11	11/11	198.00 to 204.00	199.25	203.75
12	12/12	204.00 to 210.00	205.25	209.75
13	13/13	210.00 to 216.00	211.25	215.75
23	J/23	216.00 to 222.00	217.25	221.75
24	K/24	222.00 to 228.00	223.25	227.75
25	L/25	228.00 to 234.00	229.25	233.75
26	M/26	234.00 to 240.00	235.25	239.75
27	N/27	240.00 to 246.00	241.25	245.75
28	O/28	246.00 to 252.00	247.25	251.75
29	P/29	252.00 to 258.00	253.25	257.75
30	Q/30	258.00 to 264.00	259.25	563.75

**SPECTRUM ANALYZER
OPERATION MANUAL**

9.5 TV Channel Table

(cont'd)

Analyzer's channel	Channel	Frequency range (MHz)	Picture frequency (MHz)	Sound frequency (MHz)
31	R/31	264.00 to 270.00	265.25	269.75
32	S/32	270.00 to 276.00	271.25	275.75
33	T/33	276.00 to 282.00	277.25	281.75
34	U/34	282.00 to 288.00	283.25	287.75
35	V/35	288.00 to 294.00	289.25	293.75
36	W/36	294.00 to 300.00	295.25	299.75
37	AA/37	300.00 to 306.00	301.25	305.75
38	BB/38	306.00 to 312.00	307.25	311.75
39	CC/39	312.00 to 318.00	313.25	317.75
40	DD/40	318.00 to 324.00	319.25	323.75
41	EE/41	324.00 to 330.00	325.25	329.75
42	FF/42	330.00 to 336.00	331.25	335.75
43	GG/43	336.00 to 342.00	337.25	341.75
44	HH/44	342.00 to 348.00	343.25	347.75
45	II/45	348.00 to 354.00	349.25	353.75
46	JJ/46	354.00 to 360.00	355.25	359.75
47	KK/47	360.00 to 366.00	361.25	365.75
48	LL/48	366.00 to 372.00	367.25	371.75
49	MM/49	372.00 to 378.00	373.25	377.75
50	OO/50	378.00 to 384.00	379.25	383.75
51	PP/51	384.00 to 390.00	385.25	389.75
52	QQ/52	390.00 to 396.00	391.25	395.75
53	RR/53	396.00 to 402.00	397.25	401.75
54	SS/54	402.00 to 408.00	403.25	407.75
55	TT/55	408.00 to 414.00	409.25	413.75
56	UU/56	414.00 to 420.00	415.25	419.75
57	VV/57	420.00 to 426.00	421.25	425.75
58	WW/58	426.00 to 432.00	427.25	431.75
59	AAA/59	432.00 to 438.00	433.25	437.75
60	BBB/60	438.00 to 444.00	439.25	443.75

**SPECTRUM ANALYZER
OPERATION MANUAL**

9.5 TV Channel Table

(cont'd)

Analyzer's channel	Channel	Frequency range (MHz)	Picture frequency (MHz)	Sound frequency (MHz)
61	CCC/61	444.00 to 450.00	445.25	449.75
62	DDD/62	450.00 to 456.00	451.25	455.75
63	EEE/63	456.00 to 462.00	457.25	461.75
64	/64	462.00 to 468.00	463.25	467.75
65	/65	468.00 to 474.00	469.25	473.75
66	/66	474.00 to 480.00	475.25	479.75
67	/67	480.00 to 486.00	481.25	485.75
68	/68	486.00 to 492.00	487.25	491.75
69	/69	492.00 to 498.00	493.25	497.75
70	/70	498.00 to 504.00	499.25	503.75
71	/71	504.00 to 510.00	505.25	509.75
72	/72	510.00 to 516.00	511.25	515.75
73	/73	516.00 to 522.00	517.25	521.75
74	/74	522.00 to 528.00	523.25	527.75
75	/75	528.00 to 534.00	529.25	533.75
76	/76	534.00 to 540.00	535.25	539.75
77	/77	540.00 to 546.00	541.25	545.75
78	/78	546.00 to 552.00	547.25	551.75
79	/79	552.00 to 558.00	553.25	557.75
80	/80	558.00 to 564.00	559.25	563.75
81	/81	564.00 to 570.00	565.25	569.75
82	/82	570.00 to 576.00	571.25	575.75
83	/83	576.00 to 582.00	577.25	581.75
84	/84	582.00 to 588.00	583.25	587.75
85	/85	588.00 to 594.00	589.25	593.75
86	/86	594.00 to 600.00	595.25	599.75
87	/87	600.00 to 606.00	601.25	605.75
88	/88	606.00 to 612.00	607.25	611.75
89	/89	612.00 to 618.00	613.25	617.75
90	/90	618.00 to 624.00	619.25	623.75
91	/91	624.00 to 630.00	625.25	629.75
92	/92	630.00 to 636.00	631.25	635.75
93	/93	636.00 to 642.00	637.25	641.75
94	/94	642.00 to 648.00	643.25	647.75

**SPECTRUM ANALYZER
OPERATION MANUAL**

9.5 TV Channel Table

(10) West Europe

① VHF

Table 9-39 Channel table of VHF in west Europe

Analyzer's channel	Channel	Frequency range (MHz)	Picture frequency (MHz)	Sound frequency (MHz)
2	2	47.00 to 54.00	48.25	53.75
3	3	54.00 to 61.00	55.25	60.75
4	4	61.00 to 68.00	62.25	67.75
5	5	174.00 to 181.00	175.25	180.75
6	6	181.00 to 188.00	182.25	187.75
7	7	188.00 to 195.00	189.25	194.75
8	8	195.00 to 202.00	196.25	201.75
9	9	202.00 to 209.00	203.25	208.75
10	10	209.00 to 216.00	210.25	215.75
11	11	216.00 to 223.00	217.25	222.75
12	12	223.00 to 230.00	224.25	229.75

② UHF

Table 9-40 Channel table of UHF in west Europe

Analyzer's channel	Channel	Frequency range (MHz)	Picture frequency (MHz)	Sound frequency (MHz)
21	21	470.00 to 478.00	471.25	476.75
22	22	478.00 to 486.00	479.25	484.75
23	23	486.00 to 494.00	487.25	492.75
24	24	494.00 to 502.00	495.25	500.75
25	25	502.00 to 510.00	503.25	508.75
26	26	510.00 to 518.00	511.25	516.75
27	27	518.00 to 526.00	519.25	524.75
28	28	526.00 to 534.00	527.25	532.75
29	29	534.00 to 542.00	535.25	540.75
30	30	542.00 to 550.00	543.25	548.75
31	31	550.00 to 558.00	551.25	556.75
32	32	558.00 to 566.00	559.25	564.75
33	33	566.00 to 574.00	567.25	572.75
34	34	574.00 to 582.00	575.25	580.75

**SPECTRUM ANALYZER
OPERATION MANUAL**

9.5 TV Channel Table

(cont'd)

Analyzer's channel	Channel	Frequency range (MHz)	Picture frequency (MHz)	Sound frequency (MHz)
35	35	582.00 to 590.00	583.25	588.75
36	36	590.00 to 598.00	591.25	596.75
37	37	598.00 to 606.00	599.25	604.75
38	38	606.00 to 614.00	607.25	612.75
39	39	614.00 to 622.00	615.25	620.75
40	40	622.00 to 630.00	623.25	628.75
41	41	630.00 to 638.00	631.25	636.75
42	42	638.00 to 646.00	639.25	644.75
43	43	646.00 to 654.00	647.25	652.75
44	44	654.00 to 662.00	655.25	660.75
45	45	662.00 to 670.00	663.25	668.75
46	46	670.00 to 678.00	671.25	676.75
47	47	678.00 to 686.00	679.25	684.75
48	48	686.00 to 694.00	687.25	692.75
49	49	694.00 to 702.00	695.25	700.75
50	50	702.00 to 710.00	703.25	708.75
51	51	710.00 to 718.00	711.25	716.75
52	52	718.00 to 726.00	719.25	724.75
53	53	726.00 to 734.00	727.25	732.75
54	54	734.00 to 742.00	735.25	740.75
55	55	742.00 to 750.00	743.25	748.75
56	56	750.00 to 758.00	751.25	756.75
57	57	758.00 to 766.00	759.25	764.75
58	58	766.00 to 774.00	767.25	772.75
59	59	774.00 to 782.00	775.25	780.75
60	60	782.00 to 790.00	783.25	788.75
61	61	790.00 to 798.00	791.25	796.75
62	62	798.00 to 806.00	799.25	804.75
63	63	806.00 to 814.00	807.25	812.75
64	64	814.00 to 822.00	815.25	820.75
65	65	822.00 to 830.00	823.25	828.75
66	66	830.00 to 838.00	831.25	836.75
67	67	838.00 to 846.00	839.25	844.75
68	68	846.00 to 854.00	847.25	852.75
69	69	854.00 to 862.00	855.25	860.75

**SPECTRUM ANALYZER
OPERATION MANUAL**

9.5 TV Channel Table

③ CATV

Table 9-41 Channel table of CATV in west Europe

Analyzer's channel	Channel	Frequency range (MHz)	Picture frequency (MHz)	Sound frequency (MHz)
2	S2	111.00 to 118.00	112.25	117.75
3	S3	118.00 to 125.00	119.25	124.75
4	S4	125.00 to 132.00	126.25	131.75
5	S5	132.00 to 139.00	133.25	138.75
6	S6	139.00 to 146.00	140.25	145.75
7	S7	146.00 to 153.00	147.25	152.75
8	S8	153.00 to 160.00	154.25	159.75
9	S9	160.00 to 167.00	161.25	166.75
10	S10	167.00 to 174.00	168.25	173.75
11	S11	230.00 to 237.00	231.25	236.75
12	S12	237.00 to 244.00	238.25	243.75
13	S13	244.00 to 251.00	245.25	250.75
14	S14	251.00 to 258.00	252.25	257.75
15	S15	258.00 to 265.00	259.25	264.75
16	S16	265.00 to 272.00	266.25	271.75
17	S17	272.00 to 279.00	273.25	278.75
18	S18	279.00 to 286.00	280.25	285.75
19	S19	286.00 to 293.00	287.25	292.75
20	S20	293.00 to 300.00	294.25	299.75
21	S21	302.00 to 310.00	303.25	308.75
22	S22	310.00 to 318.00	311.25	316.75
23	S23	318.00 to 326.00	319.25	324.75
24	S24	326.00 to 334.00	327.25	332.75
25	S25	334.00 to 342.00	335.25	340.75
26	S26	342.00 to 350.00	343.25	348.75
27	S27	350.00 to 358.00	351.25	356.75
28	S28	358.00 to 366.00	359.25	364.75
29	S29	366.00 to 374.00	367.25	372.75
30	S30	374.00 to 382.00	375.25	380.75
31	S31	382.00 to 390.00	383.25	388.75
32	S32	390.00 to 398.00	391.25	396.75
33	S33	398.00 to 406.00	399.25	404.75
34	S34	406.00 to 414.00	407.25	412.75
35	S35	414.00 to 422.00	415.25	420.75
36	S36	422.00 to 430.00	423.25	428.75
37	S37	430.00 to 438.00	431.25	436.75
38	S38	438.00 to 446.00	439.25	444.75

10. TRACKING GENERATOR FUNCTION (OPT-74)

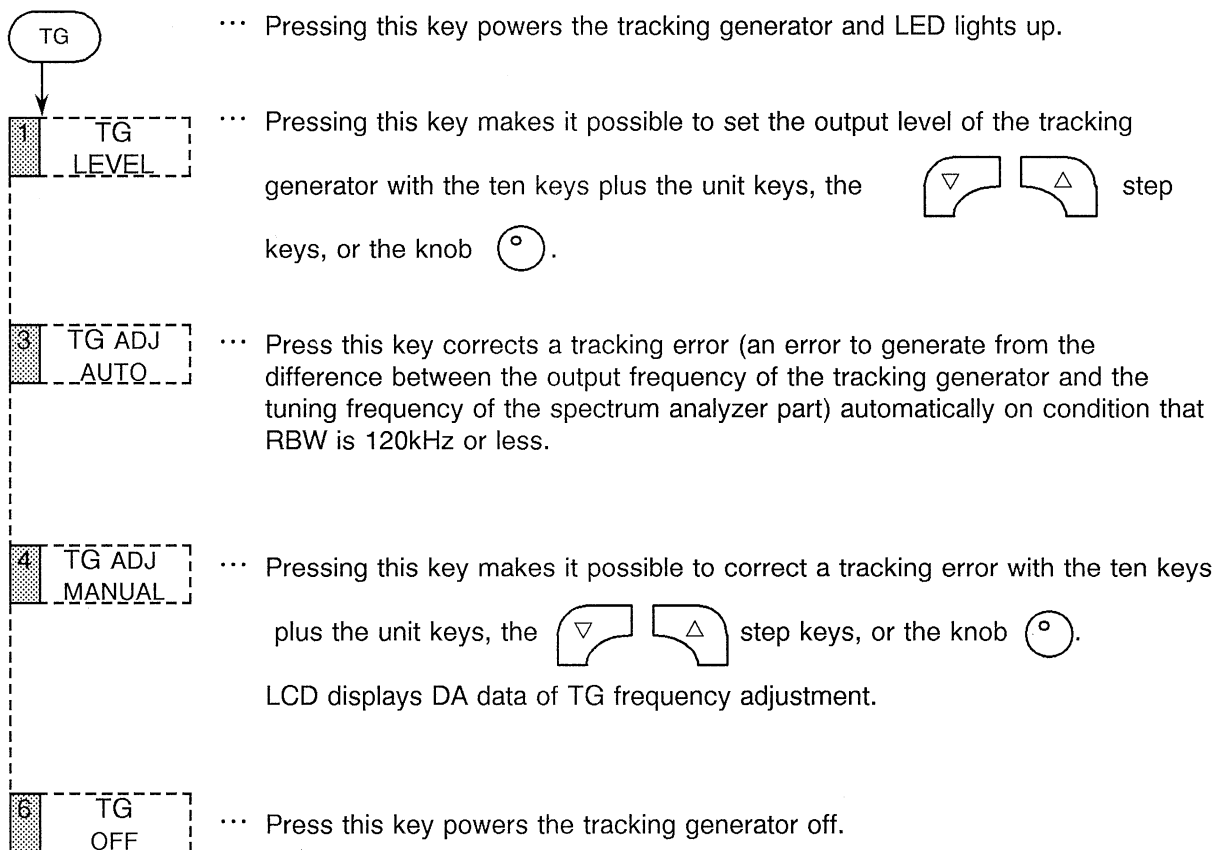

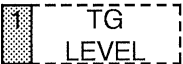

10.1 Usage of Tracking Generator

- ① Turn the tracking generator on to set its output level.

Then press   and set the output level with ten keys, step keys, or the data knob.
(It is possible to set the output level of 0dBm to -31dBm in 1dB steps.)

- ② Set a center frequency, a frequency span, and a reference level as follows.

Press  and then adjust a center frequency with the ten keys, the step keys, or the data knob.

Press  and then adjust a frequency span with the ten keys, the step keys, or the data knob.

Press  and then adjust a reference level with the ten keys, the step keys, or the data knob.

CAUTION

If resolution bandwidth is 100kHz or less, connect a cable between TG output

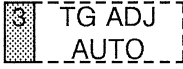
connector and RF input connector and press  to correct a tracking error (that is a level error caused by the difference between the output frequency of a tracking generator and the tuned frequency of the analyzer).

- ③ Connect a cable between TG OUTPUT connector and INPUT connector. A through-line frequency characteristic appears on the screen.

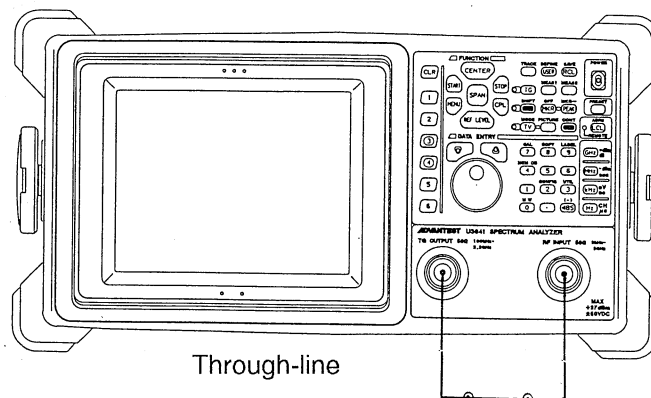

**SPECTRUM ANALYZER
OPERATION MANUAL**

10.1 Usage of Tracking Generator

- ④ If the transmission loss is not ignored, calibrate the loss according to Section 10.2.
- ⑤ Connect a device under test (DUT).

CAUTION

Match the input and output impedance of DUT to that of TG INPUT and OUTPUT.

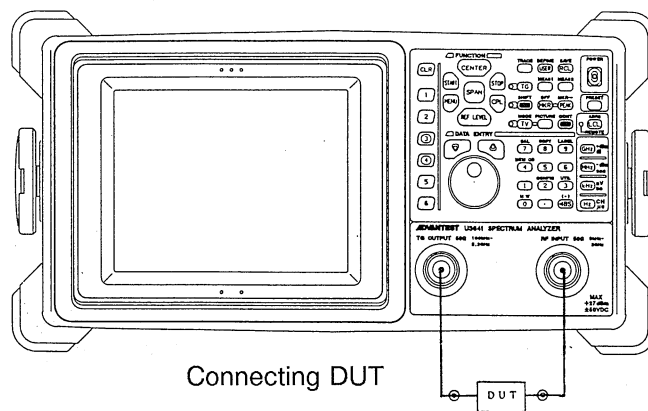

Operation is completed here.

As an application operation, next measure the filter attenuation characteristic with referring to Chapter 10.3.

RF FIELD ANALYZER
OPERATION MANUAL

10.2 How to Normalize a Frequency Characteristic with Reference to a Display Line

10.2 How to Normalize a Frequency Characteristic with Reference to a Display Line

This section explain how to normalize the frequency characteristic of a cable with reference to a trace and a display line.

This operation normalizes the frequency characteristic of the analyzer itself and allows the correct measurement of the frequency characteristic of DUT such as a filter.

CAUTION

When changing the center frequency, frequency span, reference level and so on, are changed after having normalized the analyzer, the normalization has to be made again.

- ① Connect a cable directly between the TG OUTPUT connector and the INPUT connector.

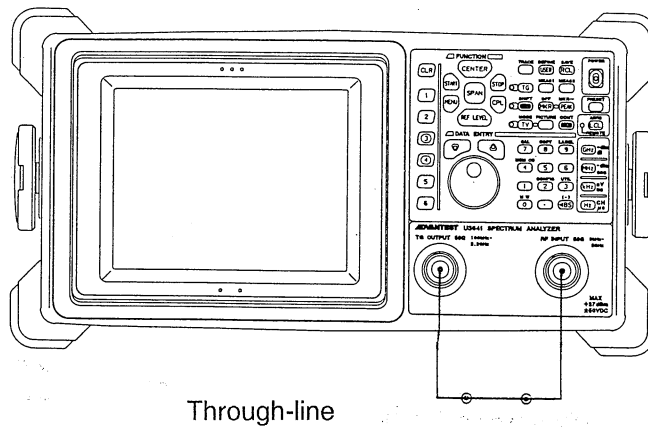



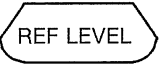

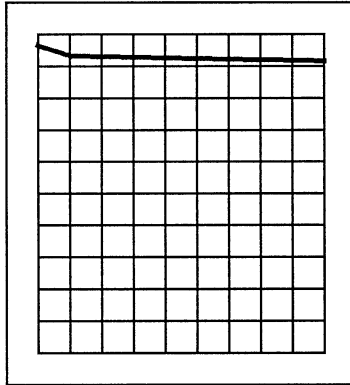
10.2 How to Normalize a Frequency Characteristic with Reference to a Display Line

- ② Press  to adjust the reference level with the step keys or the data knob.



(Waveform image)

- ③ The frequency characteristic is normalized.

Press   NEXT  TRACE MATH  NORMALIZE  INSTANT NORMALIZE

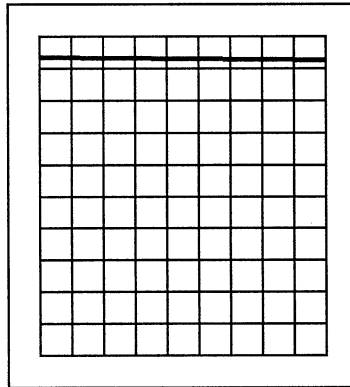

(Waveform image)

- ④ To release the normalization mode, press  NORMALIZE ON/OFF

10.3 Measurement Example of a Filter's Damping Property

The measurement of a filter and an amplifier is introduced as an example.

A band-pass filter with a passing band of around 900MHz is measured here. Its characteristics are as follows.

Center frequency	: 200MHz
Passing bandwidth (3dB)	: Approx. 4.5MHz
Insertion loss	: Approx. 5dB
Input/output impedance	: 50Ω

(1) Normalizing the Measurement System

It is necessary to adjust the tracking generator (TG). See section 10.2.

- ① Connect a through line between the TG OUTPUT connector and the INPUT connector by using measuring cables.

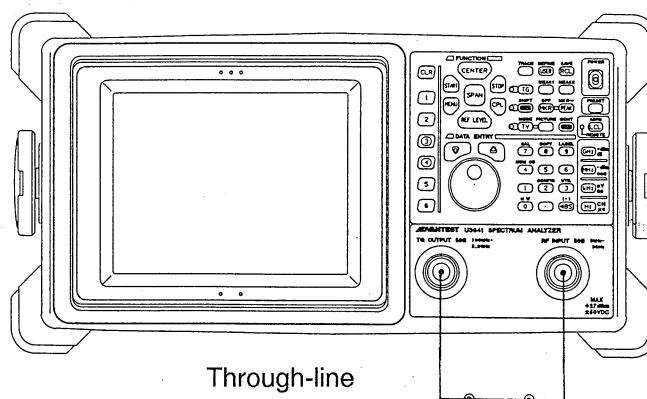

- ② Press **PRESET** to preset the analyzer.
- ③ Press **TG** to turn on TG.
- ④ Press **TG LEVEL** **0** **MHz** $\frac{-dBm}{sec}$ to set the TG output level to 0dBm.
- ⑤ Press **CENTER** **2** **0** **0** **MHz** $\frac{-dBm}{sec}$ to set the center frequency to 200MHz.

**SPECTRUM ANALYZER
OPERATION MANUAL**

10.3 Measurement Example

- ⑥ Press **SPAN** **2** **0** **MHz** $\frac{-dBm}{sec}$ to set the span to 20MHz.
- ⑦ Press **CPL** **RBW** **AUTO/MNL** **1** **0** **0** **kHz** $\frac{mV}{ms}$ to set RBW to 100kHz.
- ⑧ Press **VBW** **AUTO/MNL** **1** **kHz** $\frac{mV}{ms}$ to set VBW to 1kHz.

Note : The setting of RBW and VBW decreases the noise and make the waveform of the band-pass filter sharp.

- ⑨ Press **REF LEVEL** **1** **dB/DIV** **2** **GHz** $\frac{+dBm}{dB}$ to set the vertical axis to 2dB/div.
- ⑩ Press **REF LEVEL** and then move the waveform to the upper part of the screen by turning the data knob so that the waveform does not lie offscreen.

Press **CLR** to watch the full screen without the softkeys.

Then the screen changes as shown in Figure 10-1.

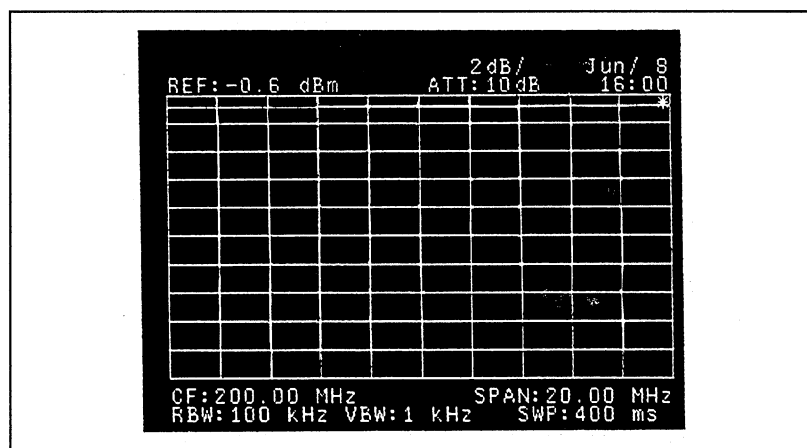

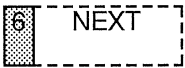
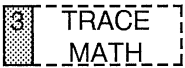
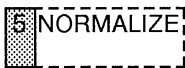



Figure 10-1 Clear Screen

Press **CLR** to recall the softkeys.

- ⑪ Press      to normalize the system of measurement.

Then the screen changes as shown in Figure 10-2.

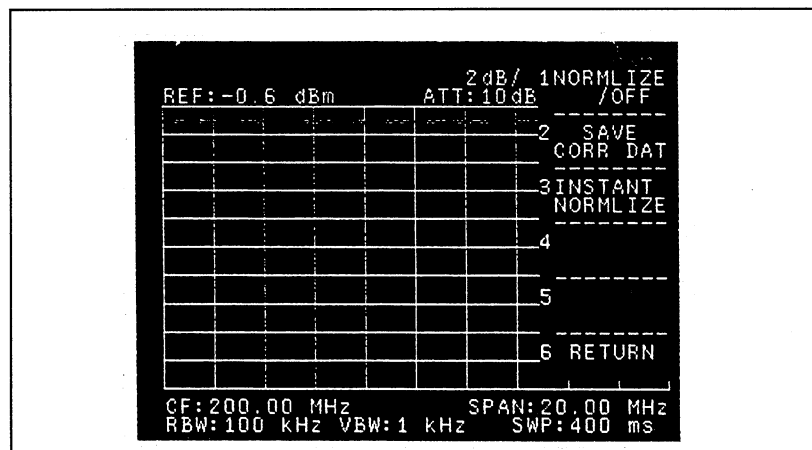

Figure 10-2 Normalize Screen

Now, the frequency characteristic became flat without DUT.

CAUTION

If functional values that have reference to normalization; for example, a center frequency, a frequency span, and a reference level, and so on, are changed under normalizing the analyzer, there is a possibility of not performing the normalization correctly. In such a case, normalize the analyzer again from the beginning.

(2) Starting Measurement

- ① Connect BPF between the TG OUTPUT connector and the INPUT connector by using measuring cables.

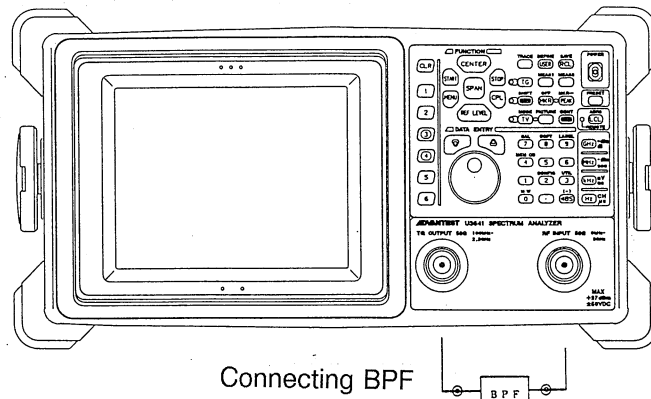

- ② Press CPL 3 SWP
AUTO/MNL 2 MHz -dBm
sec to set the sweep time to 2 seconds.

Note : This setting allows the sweep time not to influence the waveform.

Then the screen changes as shown in Figure 10-3.

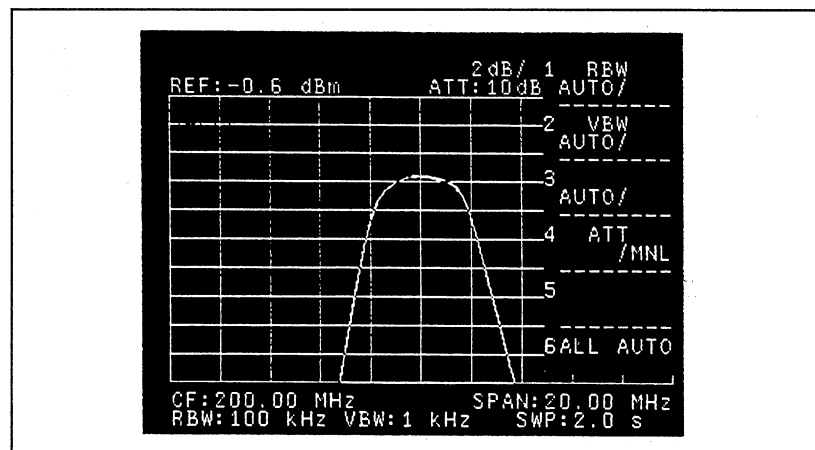

Figure 10-3 Sweep Time for 2 Seconds

Measuring the following three items.

- (a) Insertion loss
- (b) Passing bandwidth
- (c) Attenuation

(a) Measurement of an insertion loss

- ① Press **MKR** **2** **0** **0** **MHz** $\frac{-dBm}{sec}$ to locate a marker at 200MHz on the screen.

The insertion loss of 200MHz is displayed as the readout of the marker.

Note : When the display line is shown, a marker level indicates a value based on the display line.

Then the screen changes as shown in Figure 10-4.

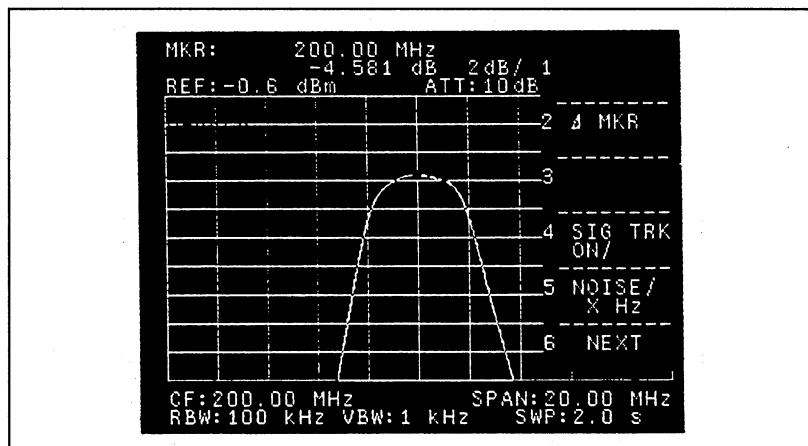

Figure 10-4 Measurement of an Insertion Loss

In this measurement, the insertion loss is 4.581dB.

(b) Measurement of a passing bandwidth (3dB)

- ① Press **MEAS2** **1** **dB** **DOWN** to set from the condition of measurement insertion loss to X dB DOWN mode.
- ② Press **3** **GHz** $\frac{+dBm}{dB}$ to make an attention 3dB.
- ③ Press **1** **XdB** **DOWN** to measure 3dB DOWN.

Then, two marker moves to points of 3dB below the level of 200MHz, respectively and then the markers indicate 3-dB passing bandwidth.

The screen becomes Figure 10-5.

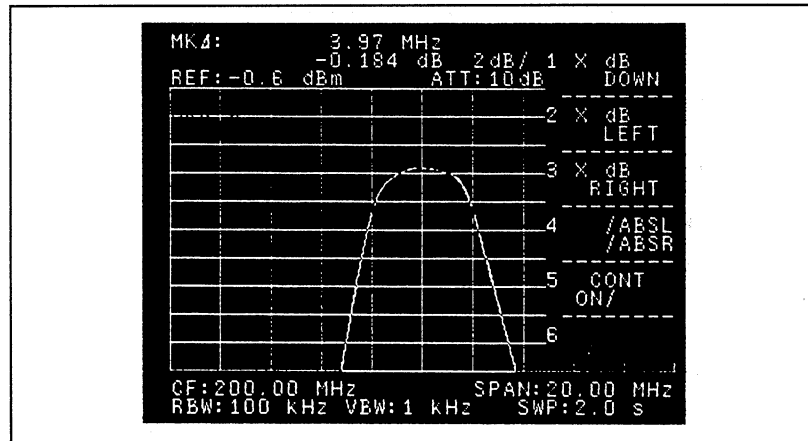

Figure 10-5 Measurement of a Passing Bandwidth

In this measurement, the 3-dB passing bandwidth is 3.97MHz.

(c) Measurement of an attenuation

Measurement of an attenuation at 14MHz, referred to the level of 200MHz.

- ① Press to release normalization because the attenuation should be measured on a scale of 10dB/DIV not to be influenced by the through-line frequency characteristic.
 - ② Press to set 10dB/DIV.
 - ③ Press to set the span to 50MHz.
 - ④ Press twice to turn the display line off.
 - ⑤ Press to set a marker to 200MHz.
 - ⑥ Press to switch from the marker to ΔMKR, and then move the ΔMKR by 14MHz high monitoring the frequency of ΔMKR.
- Press to erase the soft menu.

Then the screen changes as shown in Figure 10-6.

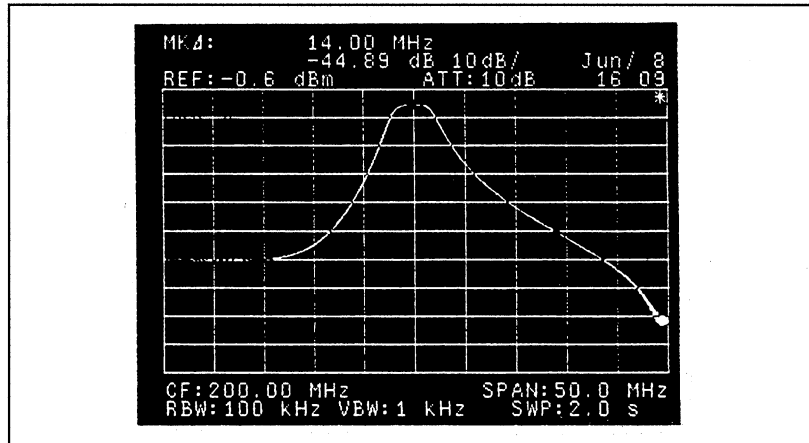

Figure 10-6 Measurement of an Attenuation

In this measurement, the attenuation is 44.89dB at the frequency of 14MHz.

10.4 Handling Precautions of Tracking Generator

(1) Dynamic Range

- ① The dynamic range of measurement is limited by the maximum output level of the TG part and the noise floor of the analyzer.
Making a resolution bandwidth RBW narrow expands the dynamic range.
If the local oscillation signal leaks from the TG part to the receiving part, there is possibilities that the noise level doesn't decrease at the maximum available resolution and that the dynamic range doesn't expand.
- ② If the loss of DUT (including its matching circuit) is big, the dynamic range also gets wrong. In such a case, the dynamic range can be improved by inserting an amplifier into the input or output port of DUT.
- ③ The location of an amplifier to be inserted is determined by conditions of DUT. Accordingly, it is necessary to study the characteristic of an amplifier to be inserted (for example, gain, flatness, noise figure, output level, 1-dB compression point, input/output VSWR, and so on).
- ④ If the tracking generator outputs an extreme large signal, decrease its output level.

(2) Time Response

- ① LCD displays a **UNCAL** message to indicate whether the level is correct or not. In the case of measuring the frequency characteristic with TG, however, ignore the **UNCAL** message.
This message indicates whether the IF filter responds sufficiently under conditions of **FREQ SPAN**, **SWP**, and **RBW** in the analyzer and whether a correct level is displayed.
- ② If the level change of a signal to be supplied from the output end of DUT to the spectrum analyzer is small, even if the **UNCAL** message is displayed, there are cases of displaying a correct level.
- ③ If the level of a signal to be supplied from the output end of DUT to the spectrum analyzer changes violently, the IF filter cannot respond.
Be careful to the time response of DUT.

**SPECTRUM ANALYZER
OPERATION MANUAL**

10.4 Handling Precautions of Tracking Generator

④ If the characteristic displayed on the screen does not change even after switching SWP, the IF filter of the analyzer and DUT is responding sufficiently. If not, slow SWP down or make SPAN narrow, until the characteristic on the screen does not change.

(3) Overvoltage Protection of TG OUTPUT Connector

Don't apply a voltage of $\pm 50V$ or more or a power of $+13dBm$ or more to TG OUTPUT connector. (It will be broken with such a voltage or a power.)

(4) Output Level Overshooting at TG Turns on

When TG turns on, approx. 2dBm output level overshoot occurs for a short time.

CAUTION

If DUT is weak in large level input, be careful to this output overshoot.

11. GPIB

11.1 Overview of the GPIB

You can control the analyzer with any remote controller or computer that uses an IEEE Standard 488-1978 (GPIB) interface. This enables you to run the analyzer remotely, and to use the analyzer to run fully or partially automated tests.

- (1) The analyzer's GPIB is fully compatible with any product that meets the IEEE 488-1978 standard. The GPIB bus allows you to connect the analyzer to other GPIB devices more easily than you can using single bus cables, making it easier to construct or modify high-grade measuring systems.
- (2) Each device on the GPIB can be assigned the role of controller, talker (sender), or listener (receiver). Devices commonly change roles while the system is operating, although there can only be one controller. Only one device can "talk" at a time, though multiple devices can "listen." The controller specifies the talker and listener addresses and transfers data from the talker to the listener. The controller itself can also play the role of talker, and can specify listener measurement conditions.
- (3) GPIB panel switches

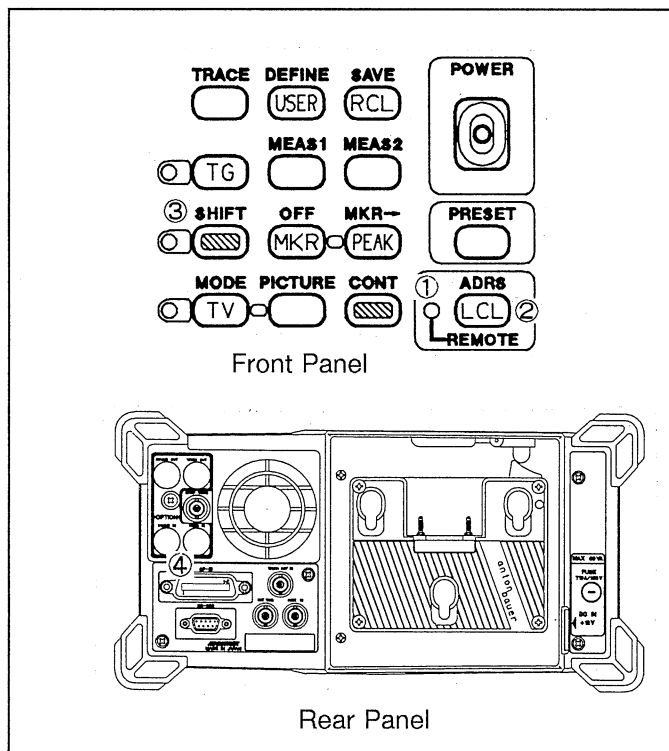

- ① Remote lamp
This lamp lights when the analyzer is set to External control mode.
- ② LCL key
This key switches the analyzer between Remote and Local control (allowing you, for example, to interrupt external control and enable input from the front panel).
- ③ SHIFT key
This key, with the LCL key, specifies the GPIB address.
- ④ GPIB connector
This terminal connects the analyzer to the external controller or to a plotter.

- (4) You can use the GPIB controller to do the following:
- ① Set measurement conditions (enter the measurement conditions as you would from the front panel)
 - ② Read (or query) existing settings and data
 - ③ Send and receive measurement data (including screen trace, data write, and read out)
 - ④ Send service requests to the controller (this interrupts the controller's current task and reads the status byte)

11.2 GPIB Specifications

(1) GPIB Bus configuration

The following figure shows the configuration of a typical GPIB system, in this case with four devices.

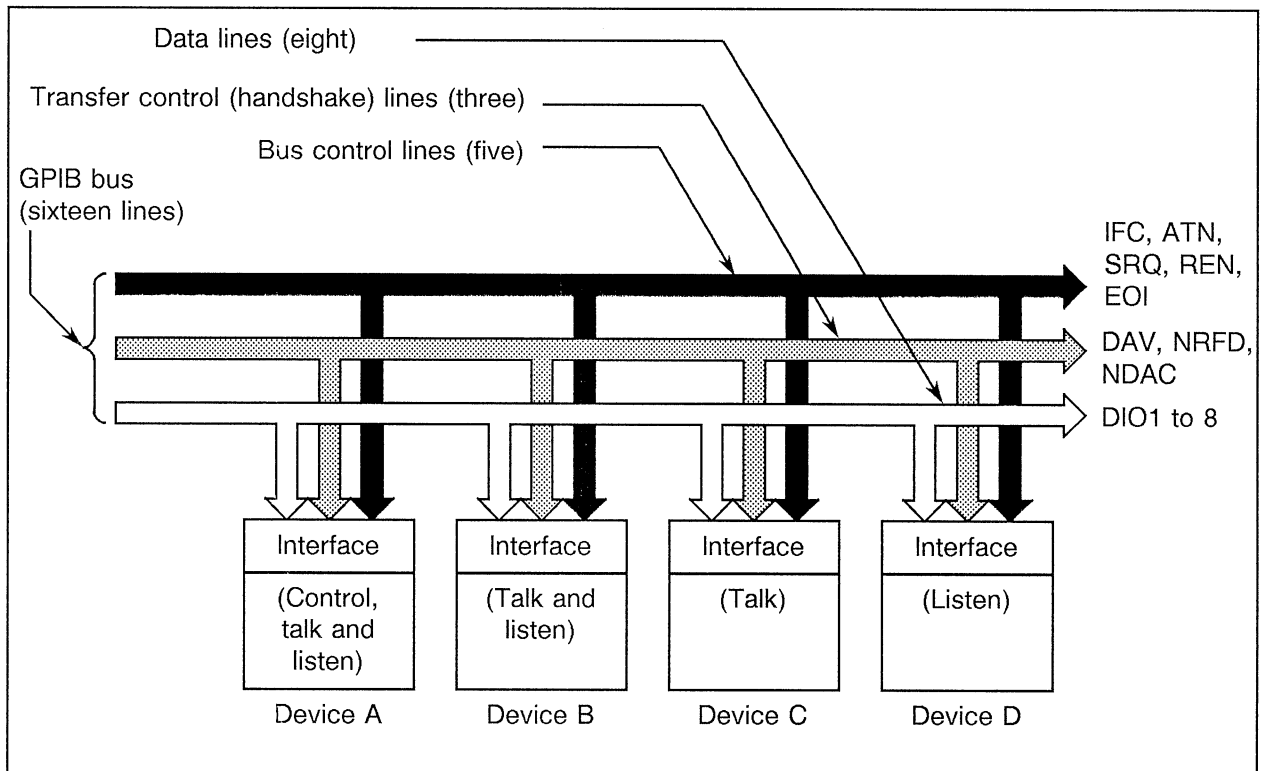

Figure 11-1 GPIB bus configuration

The GPIB bus cables include eight data lines, three transfer control lines (handshake lines), and five bus control lines. These lines function as follows:

- **Data lines:** these bit-parallel, byte-serial data lines provide asynchronous, bi-directional data transfer between devices. This allows the GPIB system to use high-speed and low-speed at the same time. Data is transferred as ASCII code.
- **Transfer control lines (handshake lines) :** these control the asynchronous data transfer between devices, and use the following signals:

DAV (Data valid) : indicates the data valid state (low state)

NRFD (Not ready for data) : indicates that data can (high state) or cannot (low state) be received

NDAC (Not data accepted) : indicates that data has (high state) or has not (low state) been received

- Bus control lines: these control the flow of information through the bus, and use the following signals:
 - ATN (Attention): determines whether the signal on the data line is a command or other information
 - IFC (Interface clear): clears the interface
 - EOI (End of identify): signals the completion of information transfer
 - SRQ (Service request): makes a service request to the controller
 - REN (Remote enable): enables remote control of a device

(2) GPIB connector assignment

The analyzer has a 24-pin GPIB connector, Amphenor product number 57-20240-D35A or its equivalent.

The following figure shows the connector and its pin assignments.

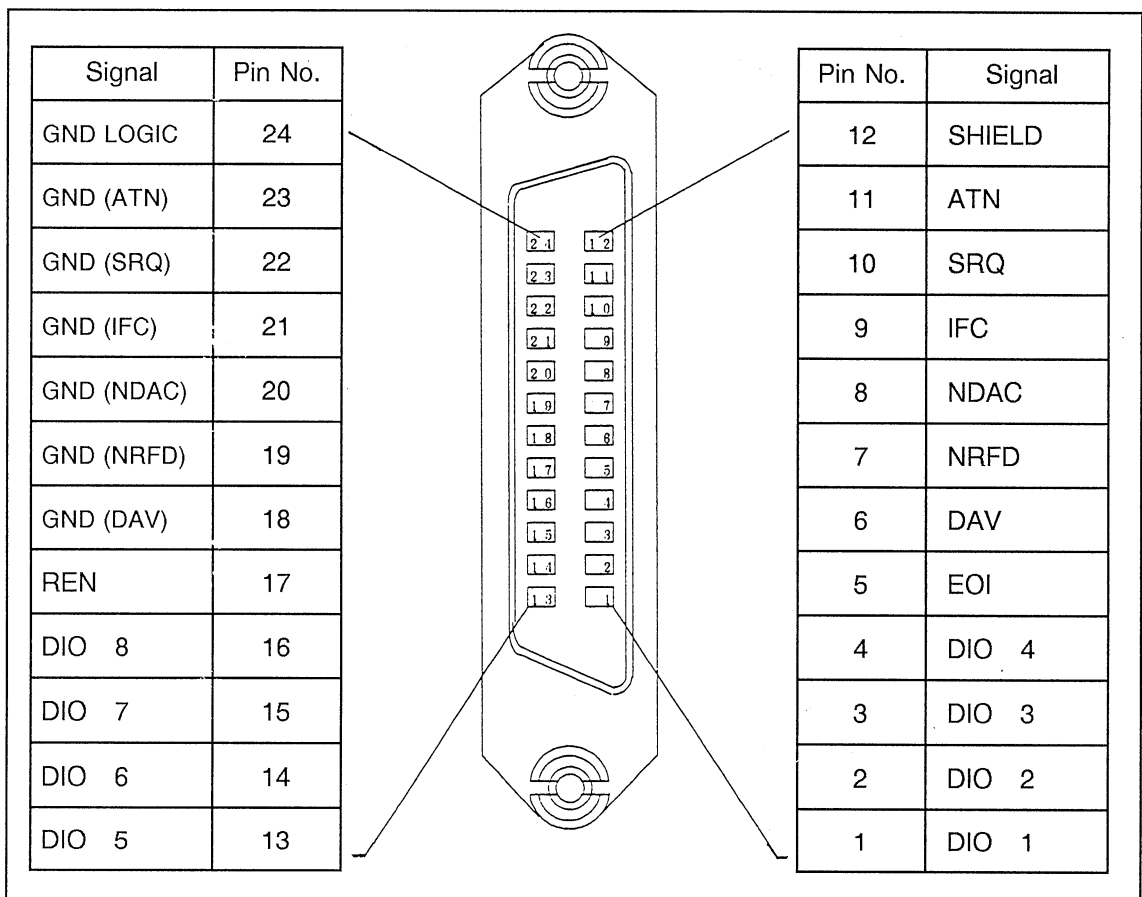

Figure 11-2 GPIB connector pin assignment

(3) GPIB specifications

- Code : ASCII, except for packed formatting (which uses binary code)
- Logic level : Logical 0 High state +2.4 V or above
Logical 1 Low state +0.4 V or below
- Signal line termination : all sixteen bus lines are terminated as shown below.

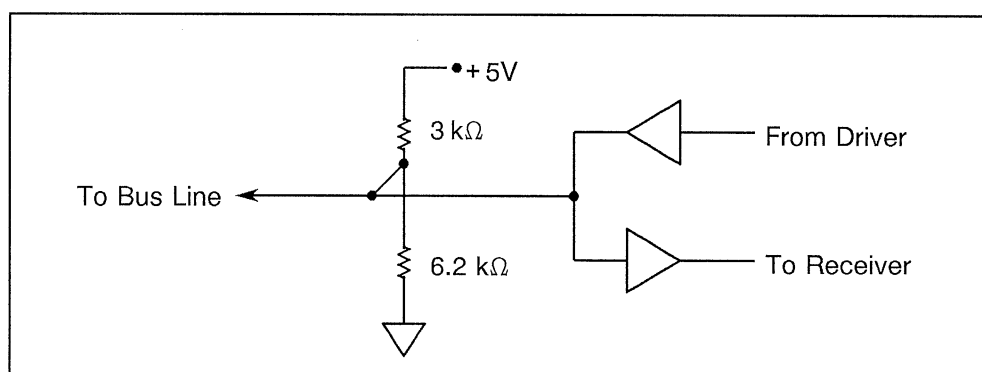

Figure 11-3 Signal line termination

- Driver : Open collector type
Output voltage at Low ... +0.4 V or below, 48 mA
at High.... +2.4 V or above, - 6.2 mA
- Receiver : +0.6 V or below ... "Low" state
+2.0 V or above ... "High" state
- Bus cable length : Connect one device for every four meters of cable you use. The total length of cable connected to the bus must be less than 20 meters.
- Addresses : Assign a unique talk/listen address (0 through 30) to each device on the bus using the front panel keys. Each device on the bus must have a unique address.

**SPECTRUM ANALYZER
OPERATION MANUAL**

11.2 GPIB Specifications

(4) GPIB interface Function: Table 11-1 describes the GPIB codes used by the analyzer.

Table 11-1 Analyzer GPIB interface codes

Code	Description
SH1	Source handshake function
AH1	Acceptor handshake function
T6	Basic talker function, Serial pole function, Talker cancel function by listener specification
L4	Basic listener function, Listener cancel function by talker specification
SR1	Service request function
RL1	Remote function
PP0	No parallel function
DC1	Device clear function provided
DT1	Device trigger function provided
C0	No controller function
E1	Used open collector bus driver; however, EOI and DAV is used a three state bus driver.

11.3 Initializing the Analyzer

Before you use the analyzer with a GPIB system, you must initialize it as described below.

11.3.1 Setting the Analyzer's GPIB Address

Set the analyzer's GPIB address (0 through 30) using front panel keys.

Example: To set the analyzer's GPIB address to 1:

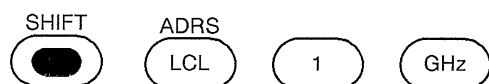

11.3.2 Defining the Delimiter

When sending data from a controller to the analyzer, use one of the delimiter codes described below to define the symbol that will be used as a message terminator: carriage return (CR), line feed (LF), or end or identify (EOI). When the analyzer sends data to the controller, one of the delimiters given below is selected.

Table 11-2 Delimiter specification codes

Code	Description
DL0	Outputs CR and LF, also outputs EOI signal together with LF
DL1	Outputs LF
DL2	Outputs EOI signal together with the data end byte
DL3	Outputs CR and LF (initial value)
DL4	Outputs LF and also EOI signal together with LF

11.4 Remote setup (Listener)

The key operation on the panel is used for setup of the measurement conditions and or parameters.

For example, to set the analyzer's center frequency to 300 MHz, you would send the following:

HP200, 300 series

<pre> OUTPUT 7 01 ; "CF 300MZ" ↑ ↑ ↑ ↑ ↑ *1 *2 *3 *4 *5 </pre>	<ul style="list-style-type: none"> *1 Specifies the controller as the talker *2 GPIB interface selector *3 Specifies the analyzer (GPIB address 01) as the listener *4 Sets the center frequency active *5 Sets the center frequency to 300 MHz
--	--

PC9801 series

<pre> PRINT @ 01 ; "CF 300MZ" ↑ ↑ ↑ ↑ ↑ *1 *2 *3 *4 *5 </pre>	<ul style="list-style-type: none"> *1 Specifies the controller as the talker *2 GPIB interface selector *3 Specifies the analyzer (GPIB address 01) as the listener *4 Sets the center frequency active *5 Sets the center frequency to 300 MHz
---	--

"CP", "3", "0" and "MZ" are GPIB code for remote control of the analyzer.

Refer to [11.9 List of GPIB code].

Following is the limitations of the input data.

- It is necessary to delimit for the command with single spaces or commas (,).
When the numeric data is input, there are not necessary.
 - "CF SP" (Correct)
 - "CFSP" (Incorrect)
 - "CF 300 MZ" (Correct)
 - "CF300MZ" (Correct)
 - "DL 1DB" (Set 1dB for the display line.)
 - "DL1DB" (Set "LF" for the delimiter.)
- Numeric data of the binary cannot be input. (except trace binary input). Carriage return (CR) and line feed (LF) is recognized only for the data delimiter.
- It cannot be input except defined GPIB code.
- If not-yet-defined GPIB code is input then it becomes Syntax error.

**SPECTRUM ANALYZER
OPERATION MANUAL**

11.4 Remote setup (Listener)

HP200 and 300 series programming examples (GPIB address = 1)

Example HP-1: Master-reset the analyzer and set the center frequency to 25 MHz.	
10 OUTPUT 701;"IP"	
20 OUTPUT 701;"CF25MZ"	
30 END	
Example HP-2: Set the start and stop frequencies to 300 kHz and 800 kHz, respectively, and add 50 kHz to the frequency offset.	
10 OUTPUT 701;"FA300KZ"	
20 OUTPUT 701;"FB800KZ"	
30 OUTPUT 701;"FON50KZ"	
40 END	
Example HP-3: Set the reference level to -20 dBm (5 dB/div), resolution bandwidth to 100 kHz, and detector mode to positive.	
10 OUTPUT 701;"RE-20DB"	
20 OUTPUT 701;"DD5DB"	
30 OUTPUT 701;"RB100KZ"	
40 OUTPUT 701;"DTP"	
50 END	
Example HP-4: Set the trigger mode to single and the sweep time to 2 seconds, and match the marker with the maximum level at each sweep.	
10 OUTPUT 701;"SI"	
20 OUTPUT 701;"SW2SC"	
30 OUTPUT 701;"SR"	! Starts the sweep.
40 WAIT 2.5	! Pauses the analyzer until the sweep ends (or a service request is received).
50 OUTPUT 701;"PS"	! Peak search of the marker frequency
60 GOTO 30	
70 STOP	
80 END	

**SPECTRUM ANALYZER
OPERATION MANUAL**

11.4 Remote setup (Listener)

PC9801 series programming examples (GPIB address = 8)

Example PC-1: Master-reset the analyzer and set the center frequency to 25 MHz.	
10 ISET IFC:ISET REN	' Executes the interface clear and the remote enable.
20 PRINT @8;"IP"	' Executes the master reset.
30 PRINT @8;"CF25MZ"	' Sets the center frequency to 25MHz.
40 END	
Example PC-2: Set the start and stop frequencies to 300 kHz and 800 kHz, respectively, and add 50 kHz to the frequency offset.	
10 ISET IFC:ISET REN	
20 PRINT @8;"FA300KZ"	' Sets the start frequency to 300kHz.
30 PRINT @8;"FB800KZ"	' Sets the stop frequency to 800kHz.
40 PRINT @8;"FON50KZ"	' Sets the frequency offset to 50kHz.
50 END	
Example PC-3: Set the reference level to 87 dB μ V (5 dB/div), resolution bandwidth to 100 kHz.	
10 ISET IFC:ISET REN	
20 PRINT @8;"UU RE87DB"	' Sets the reference level to 87 dB μ V.
30 PRINT @8;"DD5DB"	' Sets 5dB/.
40 PRINT @8;"RB100KZ"	' Sets the resolution bandwidth to 100 kHz.
50 END	
Example PC-4: Set the value by a variable.	
10 ISET IFC:ISET REN	
20 SPA = 8:A = 10:B = 2:C = 20	' Assigns the set value to each variable.
30 PRINT @SPA;"CF",A,"MZ"	' Sets the center frequency to 10 MHz.
40 PRINT @SPA;"SP",B,"MZ"	' Sets the frequency span to 2 MHz.
50 PRINT @SPA;"AT",C,"DB"	' Sets the attenuator 20 dB.
60 END	

Example PC-5: Save the set value in memory card of drive A with the file name "SAVEDATA" and execute the recalling.

```

10 ISET IFC:ISET REN
20 PRINT @8;"SV /A:SAVEDATA"           ' Executes the saving
30 PRINT @8;"IP"                       ' Executes the master reset.
40 PRINT @8;"RC /A:SAVEDATA"           ' Executes the recalling.
50 END

```

Example PC-6: Set the softkey menu display OFF.

```

10 ISET IFC:ISET REN
20 PRINT @8;"MND OFF"                   ' Sets the softkey menu display to OFF.
30 PRINT @8;"CF30MZ SP20MZ"
40 PRINT @8;"PS"
50 END

```

Example PC-7: Input the limit line 1 table and set it ON.

```

10 ISET IFC:ISET REN
20 PRINT @8;"IP"
30 PRINT @8;"LMTADEL"                   ' Deletes the limit line 1 table.
40 PRINT @8;"UJ LMTAIN"                 ' Specifies the unit to dB $\mu$ V and the data input to the
50 '                                     table.
60 PRINT @8;"25MZ 49.5DB"               ' Inputs the data of the limit line 1.
70 PRINT @8;"27MZ 50.5DB"
80 PRINT @8;"29MZ 51.5DB"
90 PRINT @8;"31MZ 52.5DB"
100 PRINT @8;"36MZ 54.3DB"
110 PRINT @8;"40MZ 55.9DB"
120 PRINT @8;"43MZ 57.0DB"
130 PRINT @8;"46MZ 58.0DB"
140 PRINT @8;"52MZ 60.5DB"
150 PRINT @8;"63MZ 63.0DB"
160 PRINT @8;"67MZ 64.0DB"

```

SPECTRUM ANALYZER
OPERATION MANUAL

11.4 Remote setup (Listener)

(cont'd)		
170	PRINT @8;"69MZ 64.6DB"	
180	PRINT @8;"75MZ 64.7DB"	
190	'	
200	PRINT @8;"FA0MZ FB100MZ"	' Sets the start frequency and stop frequency.
210	PRINT @8;"LMTA ON"	' Sets the limit line 1 to ON.
220	END	
Example PC-8: Measurement example of DELAY SWEEP		
10	ISET IFC:ISET REN	' Executes interface clear and remote enabling.
20	PRINT @8;"VIDEO DLY 30HZ"	' Makes a trigger with the VIDEO signal and the trigger level to 30%.
30	PRINT @8;"TRIGSLP DLY +"	' Makes a trigger at the leading edge of the VIDEO signal.
40	PRINT @8;"DLYPOS 10US"	' Sets the DELAY time to 10 μ s.
50	PRINT @8;"DLYSWPTIM 4.5MS"	' Sets the DELAY sweep time to 4.5 ms.
60	PRINT @8;"DLYSWP ON"	' Sets DELAY SWEEP to ON.
70	END	

11.5 Data output (Talker)

For the output of internal data such as the measurement data or the status conditions, pre-assignment to the data to be output is necessary with "xx?" command.

When the analyzer entered talker mode, the assigned data is read out. The following table shows rough classification of the output format.

The type of the output data is shown by the header that is put at the first of the character string and five type delimiters can be used for the terminating output data.

Refer to [11.9 list of GPIB code]. Assigned command of "xx?" is effective until it is changed.

SPECTRUM ANALYZER
OPERATION MANUAL

11.5 Data output (Talker)

HP200 and 300 series programming examples (GPIB address = 1).

Example 5: Output the marker frequency.	
10 OUTPUT 701;"MF?"	
20 ENTER 701;A	
30 END	Result: A = 1.8E + 9
Example 6: Output the center frequency.	
10 DIM A\$ (30)	
20 OUTPUT 701;"HD1"	
30 OUTPUT 701;"CF?"	
40 ENTER 701;A\$	
50 END	Result: A\$ = CF 00001.234567E + 9
Example 7: Output the unit state.	
10 OUTPUT 701;"UN?"	
20 ENTER 701;A	
30 END	Result: A = 2 (dB μ V)
Example 8: Output the marker frequency and level.	
10 OUTPUT 701;"MFL?"	
20 ENTER 701;Mf,M1	
30 END	Result: Mf = 1.8E + 9 M1 = - 65.15
Example 9: Output the frequency offset.	
10 OUTPUT 701;"FO?"	
20 ENTER 701;On,Frq	
30 END	Result: On = 1 Frq = 1.23E + 6
Example 10: Using NEXT PEAK, read the first 10 signal peak levels, starting at the second peak.	
10 DIM M1(9)	
20 OUTPUT 701;"PS"	
30 FOR I= 0 TO 9	
40 OUTPUT 701;"NXP"	
50 OUTPUT 701;"ML?"	
60 ENTER 701;M1(I)	
70 NEXT I	
80 END	Result: M1(0) = - 55.01 M1(1) = - 58.22 ... M1(9) = - 70.26

PC9801 series programming examples (GPIB address = 8).

Example PC-9: Output the maker level (Numerical variable)	
10 ISET IFC: ISET REN 20 PRINT @8;"HD0" 30 PRINT @8;"ML?" 40 PRINT @8;ML 50 PRINT "MARKER LEVEL = ",ML 60 END	' Sets the header OFF. ' Marker level ? ' Reads the marker level. ' Outputs results on the display.
Result: MARKER LEVEL = -16.22	
Example PC-10: Output the center frequency. (Character variable)	
10 ISET IFC: ISET REN 20 PRINT @8;"HD1" 30 PRINT @8;"CF?" 40 INPUT @8;CF\$ 50 PRINT CF\$ 60 END	' Sets the header ON. ' Reads the center frequency. ' Outputs results on the display.
Result: CF 000025.000000E + 6	
Example PC-11: Output the unit of the level and the level.	
10 ISET IFC: ISET REN 20 PRINT @8;"HD1" 30 PRINT @8;"RE?" 40 INPUT @8;RE\$ 50 PRINT @8;"UN?" 60 INPUT @8;UN 70 PRINT RE\$,":",UN 80 END	' Sets the header ON. ' Reads the reference level. ' Reads the unit of the level. ' Outputs results on the display.
Result: REB 000000.0E + 0 : 0	

**SPECTRUM ANALYZER
OPERATION MANUAL**

11.5 Data output (Talker)

<p>Example PC-12: Execute 6 dB down then output the frequency and level (more than one).</p> <hr style="border-top: 1px dashed black;"/> <pre> 10 ISET IFC:ISET REN 20 PRINT @8;"HD0" ' Sets the header OFF. 30 PRINT @8;"CF30MZ SP20MZ" ' Sets the center frequency and the frequency span. 40 PRINT @8;"TS PS MKBW6DB XDB" ' After one sweep, executes peak search and 6 dB down. 50 PRINT @8;"MFL?" ' Reads the marker frequency and level at a time. 60 INPUT @8;MF,ML 70 PRINT "MARKER FREQ" = ";"MF;" : MARKER LEVEL = ";"ML 80 END Result: MARKER FREQ = 400000 : MARKER LEVEL = 1.16 </pre>
<p>Example PC-13: Execute OBW and output the operation results.</p> <hr style="border-top: 1px dashed black;"/> <pre> 10 ISET IFC:ISET REN 20 PRINT @8;"HD0" ' Sets the header OFF. 30 PRINT @8;"OBW" ' Executes OBW. 40 PRINT @8;"OBW?" ' Percentage, occupied band width, carrier frequency 50 INPUT@8;PER,OBW,FC 60 PRINT "OBW (" ;PER;"%) = ";"OBW;" : Fc = ";"FC 70 END Result: OBW (99%) = 171000 : Fc = 2.503E + 07 </pre>
<p>Example PC-14: Output the level of the maximum peak, the second and third peaks of the signal.</p> <hr style="border-top: 1px dashed black;"/> <pre> 10 ISET IFC:ISET REN 20 PRINT @8;"HD0 ML?" ' Sets the header OFF. 30 PRINT @8;"PS" 40 INPUT @8;A ' Reads the peak level. 50 PRINT @8;"NXP" 60 INPUT @8;B ' Reads the second peak level. 70 PRINT @8;"NXP" 80 INPUT @8;C ' Reads the third peak level. 90 PRINT "1st PK = ";"A;" : 2nd PK = ";"B;" : 3rd PK = ";"C 100 END Result: 1st PK = -9.44 : 2nd PK = -10.06 : 3rd PK = -11.84 </pre>

11.6 Inputting and Outputting Trace Data

The trace data on the screen is consisted with 701 points data on the frequency axis. For the purpose of input and output of the data, 701 points data transmitted in order from the left (start frequency).

The level value of the each point is expressed in the integer of 0 to 340 or 0 to 2720. (However, 400 or the value exceeding 3648 are expressed for the over scaled data.)

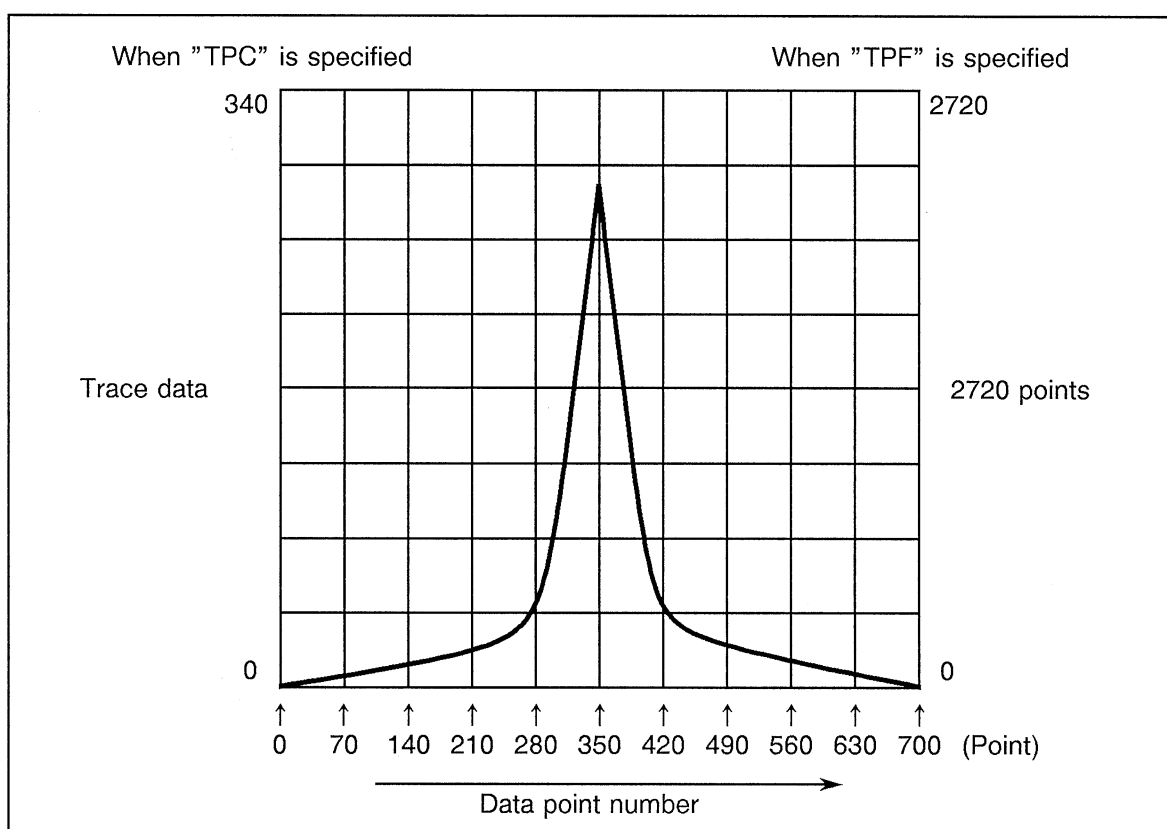
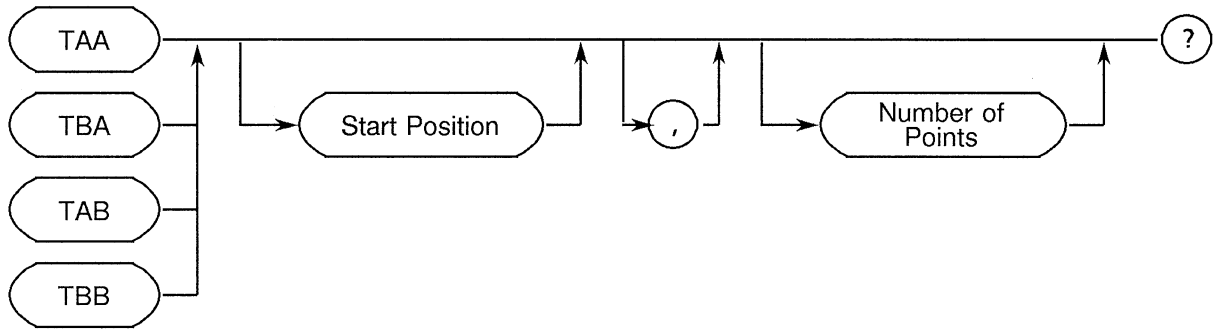

Figure 11-4 Relation between screen grid and data points

Table 11-3 shows the GPIB commands used to select TPC or TPF format.

Table 11-3 Trace accuracy codes

GPIB Code	Description
TPC	The trace data is input or output in the accuracy of 0 to 340.
TPF	The trace data is input or output in the accuracy of 0 to 2720.



- The start position : is assigned by 0 to 700. Default value is zero.
- The number of output data : start position + number of output data \leq 701. This number must be 701 or less. Default value is 701.

**SPECTRUM ANALYZER
OPERATION MANUAL**

11.6 Inputting and Outputting Trace Data

HP200 and 300 series programming examples (GPIB address = 1)

Example HP-11: Output ASCII data from memory A.	
10 DIM Tr(700) 20 OUTPUT 701;"DL3" 30 OUTPUT 701;"TAA?" 40 FOR I = 0 TO 700 50 ENTER 701;Tr(I) 60 NEXT I 70 END	! Fetches 701 variables. ! Specifies CR LF as the delimiter. ! Specifies that data will be read from memory A in ASCII format. ! Fetches data 701 times.
Result: Tr(0) = 208 Tr(1) = 210...Tr(699) = 311 Tr(700) = 298.	
Example HP-12: Output binary data from memory B.	
10 DIM Tr(700) 20 OUTPUT 701;"DL2" 30 OUTPUT 701;"TBB?" 40 ENTER 701 USING "%,W";Tr(*) 50 END	! Fetches 701 variables. ! Specifies EOI as the delimiter. ! Specifies that data will be read from memory B in ASCII format. ! Fetches data through word conversion until the EOI is received.
Result: Tr(0) = 312 Tr(1) = 319...Tr(699) = 208 Tr(700) = 211.	
Example HP-13: Input ASCII data to memory A.	
10 INTEGER Tr(700) 20 OUTPUT 701;"TAA" 30 FOR I = 0 TO 700 40 OUTPUT 701;Tr(I) 50 NEXT I 60 END	! Specifies that data will be read from memory A in ASCII format. ! Inputs 701 variables.
Note: Specify VIEW mode before executing the program. After execution is complete, press the VIEW key again to confirm the input result.	

HP200 and 300 series programming examples (GPIB address = 1).

Example HP-14: Input binary data to memory B.	
10 INTEGER Tr(700)	
20 OUTPUT 701;"TBB"	! Specifies binary data to be input to memory B.
30 OUTPUT 701 USING "#,W";Tr(*),END	! Inputs 701 data in word size and adds EOI at the end.
40 END	
Note: Specify VIEW mode before executing the program. After execution is complete, press the VIEW key again to confirm the input result.	

Note: If the data is in ASCII format, specify 701 as the the number of I/O processings.
If the data is in binary format, fetch 701 data items and specify EOI as the delimiter.

PC9801 series programming examples (GPIB address = 8).

Example PC-15: Output the A memory data in ASCII (0 to 340)	
10 ISET IFC:ISET REN	' Executes interface clear and remote enabling.
20 DIM TR(701)	
30 PRINT @8;"DL0 TPC DTG"	' Sets the negative detector and the trace accuracy for 0 to 340.
40 PRINT @8;"TAA?"	' Specifies the memory A for the ASCII output.
50 FOR I = 0 TO 700	
60 INPUT @8;TR(I)	' Reads data for 701 points.
70 PRINT I;" = ";TR(I)	
80 NEXT I	
90 END	
Result: Tr (0) = 208 Tr (1) = 210.... Tr (699) = 311 Tr (700) = 298	

Example PC-16: Output the A memory data in BINARY (0 to 340)	
10 ISET IFC:ISET REN	' Executes interface clear and remote enabling.
20 DIM TR(701)	
30 PRINT @8;"DL2 TPC DTG"	' Sets the negative detector and the trace accuracy for 0 to 340.
40 PRINT @8;"TBA?"	' Specifies the memory A for the binary output.
50 WBYTE &H3F,&H5F,&H3E,&H48;	' Releases the listener and addresses PC9801 to listener 30 and this analyzer to talker 8.
60	
70 FOR I= 0 TO 700	
80 RBYTE ;UP,LO	' Repeats data reading for every upper byte and lower byte corresponding to 701 points.
90 TR(I) = UP*256 + LO	
100 PRINT I;" ";TR(I)	
110 NEXT I	
120 WBYTE &H3F,&H5F;	' Releases the listener and talker.
130 END	
Result: Tr (0) = 312 Tr (1) = 319.... Tr (699) = 208 Tr (700) = 211	
Example PC-17: Input data to the memory A in ASCII (0 to 340)	
10 ISET IFC:ISET REN	' Executes interface clear and remote enabling.
20 A = 0:ST = 3.14/100	
30 PRINT @8;"TPC AB TAA"	' Specifies the memory A for the ASCII input. (Accuracy of 0 to 340)
40 FOR I= 0 TO 700	
50 N = INT(SIN(A)*170) + 170	
60 A = A + ST	
70 PRINT @8;N	
80 NEXT I	
90 PRINT @8;N"AV"	' A VIEW
100 END	

SPECTRUM ANALYZER
OPERATION MANUAL

11.6 Inputting and Outputting Trace Data

Example PC-18: Input data to the memory A in BINARY (0 to 340)

```
10 ISET IFC:ISET REN          ' Executes interface clear and remote enabling.
20 DIM DT(701)
30 A = 0:ST = 3.14/100
40 FOR I = 0 TO 700
50   DT(I) = INT(COS(A)*170) + 170  ' Creates the transferring data.
60   A = A + ST
70 NEXT I
80 PRINT @8;"TPC AB CWA TBA"      ' Specifies the memory A for the binary input. (0 to 340)
90 FOR I = 0 TO 699
100  WBYTE ; INT(DT(I)/256), DT(I) MOD 256
                                     ' Transfers data for every upper byte and lower byte.
110 NEXT I
120 WBYTE ; INT(DT(700)/256), DT(700) MOD 256@
                                     ' Outputs the EOI signal together with the net data.
130 PRINT @8;"AV"                ' A VIEW
140 END
```

11.7 Service Request (SRQ)

When GPIB function of the service request is used, each status of the analyzer can be detected from outside. When the service request is occurred in single following descriptions, the corresponding status bit is set to 1, and the controller can determine the analyzer status by reading the status byte in the serial polling.

Table 11-5 Service request ON/OFF codes

GPIB code	Description
S0	Enables the SRQ function.
S1	Disables the SRQ function. (This is the default setting.)
S2	Clears the status register.

Table 11-6 Status register bit assignments

Bit	Decimal	Description
0	1	Turns ON when UNCAL occurs.
1	2	Turns ON when calibration is complete.
2	4	Turns ON when a sweep is complete.
3	8	Turns ON when the specified number of averagings is complete.
4	16	Turns ON when plot output is complete.
5	32	Turns ON when an error is found in the GPIB code or a mode error occurs (SYNTAX ERR).
6	64	Turns ON when bits 0 through 5 or 7 when a service request is transmitted (S0).
7	128	

**SPECTRUM ANALYZER
OPERATION MANUAL**

11.7 Service Request (SRQ)

HP200 and 300 series programming examples (GPIB address = 1).

Example HP-15: Read the average end. (SRQ is not enabled.)	
10 OUTPUT 701;"S2"	! Clears the status register.
20 OUTPUT 701;"AG 30GZ"	! Starts averaging.
30 S = SPOLL(701)	! Reads the status register into S.
40 IF BIT(S,3) < > 1 THEN 30	! Loops until bit 3 turns ON.
50 DISP "AVG.END"	
60 END	
Example HP-16: Continuously read out the single sweep end. (SRQ is not enabled.)	
10 OUTPUT 701;"SI"	! Sets the mode to single.
20 OUTPUT 701;"S2"	! Clears the status register.
30 OUTPUT 701;"SR"	! Starts the sweep.
40 S = SPOLL(701)	! Reads the status register into S.
50 IF BIT(S,2) < > 1 THEN 40	! Waits until bit 2 turns ON.
60 PRINT "SWEEP END"	
70 GOTO 20	! Starts the next sweep.
80 END	
Example HP-17: Read out the average end. (SRQ is enabled.)	
10 OUTPUT 701;"S0"	! Enables SRQ.
20 OUTPUT 701;"S2"	! Clears the status register.
30 OUTPUT 701;"AG"	! Starts averaging.
40 ON INTR 7 GOTO 70	! Jumps to line 70 when an interrupt occurs.
50 ENABLE INTR 7;2	! Sets the analyzer to receive an interrupt.
60 GOTO 50	! Loops until an interrupt occurs.
70 S = SPOLL(701)	! Reads the status register into S.
80 IF BIT(S,3) = 1 THEN 110	! Jumps to line 110 if bit 3 is ON.
90 OUTPUT 701;"S2"	! Clears the status register.
100 GOTO 40	! Repeats.
110 DISP "AVG.END"	
120 END	

**SPECTRUM ANALYZER
OPERATION MANUAL**

11.7 Service Request (SRQ)

PC9801 series programming examples (GPIB address = 8).

Example PC-19: Read the average end. (SRQ is not enabled.)	
10 ISET IFC:ISET REN 20 PRINT @8;"S2" 30 PRINT @8;"AG 30GZ" 40 *LOOP 50 POLL 8,S 60 IF (S AND 8) = 0 THEN GOTO *LOOP 70 END	' Clears the status byte. ' Starts averaging A. ' Reads the status byte into variable S. ' Executes the loop until 1 stands at the third bit.
Example PC-20: Read out the end of the sweep and execute a single sweep. (The SRQ interrupt is not output.)	
10 ISET IFC:ISET REN 20 PRINT @8;"SI" 30 *LOOP 40 PRINT @8;"S2" 50 PRINT @8;"SR" 60 *SPOLL 70 POLL 8,S 80 IF (S AND 4) = 0 THEN GOTO *SPOLL 90 BEEP:GOTO *LOOP 100 END	' Sets the single sweep. ' Clears the status byte. ' Starts the sweep. ' Reads the status byte into variable S. ' Executes the loop until 1 stands at the second bit. ' Beeps out the end of the sweep.
Example PC-21: Read out the peak frequency and level at every end of the single sweep. (The SRQ interrupt is not output.)	
10 ISET IFC:ISET REN 20 PRINT @8;"HD0 SI MFL?" 30 ON SRQ GOSUB *SPOLL 40 PRINT @8;"S0" 50 SRQ ON 60 POLL 8,S 70 *LOOP 80 SWP = 0 90 PRINT @8;"SR"	' Sets the header OFF and the single sweep. ' Specifies the jump destination when the SRQ interrupt is received. ' Sets the analyzer so as to output the SRQ interrupt. ' Sets PC9801 for enabling the SRQ interrupt. ' Clears the status byte. ' Starts the sweep.

SPECTRUM ANALYZER
OPERATION MANUAL

11.7 Service Request (SRQ)

(cont'd)	
<pre> 100 *INTWAIT 110 IF SWP = 0 THEN GOTO *INTWAIT 120 ' 130 PRINT @8;"PS" 140 INPUT @8;"MF,ML" 150 PRINT "PEAK FREQ = ";MF;" : PEAK LEVEL = ";ML 160 GOTO *LOOP 170 ' 180 *SPOLL 190 POLL 8,S 200 IF (S AND 4) < > 0 THEN BEEP: SWP = 1 210 RETURN </pre>	<pre> ' Waits for an interrupt. ' Executes the peak search. ' Reads the marker frequency and level. ' Reads the status byte into variable S. ' Reads the status byte into variable S. ' Ends the sweep if 1 stands at the second bits. </pre>
<p>Example PC-22: Read out the peak and the second peak of the measurement waveform with the marker counter.</p>	
<pre> 10 ISET IFC: ISET REN 20 PRINT @8;"HD0 MND OFF" 30 PRINT @8;"MFL?" 40 PRINT @8;"CF30MZ SP10MZ" 50 PRINT @8;"SI" 60 GOSUB *SWEEP 70 PRINT @8;"CN1" 80 PRINT @8;"PS" 90 GOSUB *SWEEP 100 INPUT @8;MF1,ML1 110 PRINT @8;"NXP" 120 GOSUB *SWEEP 130 INPUT @8;MF2,ML2 140 PRINT "1st PEAK = ";MF1;" : ";ML1,"2nd PEAK = ";MF2;" : ";ML2 150 END 160 *SWEEP </pre>	<pre> ' Sets the header OFF. ' Sets various data. ' Sets the single sweep. ' Executes one sweep. ' Executes the counter and the peak search. ' Executes one sweep. ' Reads the marker frequency and level. ' Executes the next peak search. ' Executes one sweep. ' Reads the second peak frequency and level. </pre>

**SPECTRUM ANALYZER
OPERATION MANUAL**

11.7 Service Request (SRQ)

(cont'd)	
<pre> 170 PRINT @8;"S2" 180 PRINT @8;"SI" 190 *SPOLL 200 POLL 8,S 210 IF (S AND 4) = 0 THEN GOTO *SPOLL 220 BEEP:RETURN </pre>	<pre> ' Clears the status byte. ' Starts the sweep. ' Waits for the end of the sweep. </pre>
<p>Example PC-23: After executing the sweep twice, read out the peak frequency and level. (Use the TS command instead of SRQ.)</p>	
<pre> 10 ISET IFC:ISET REN 20 PRINT @8;"IP HD0" 30 PRINT @8;"SP10MZ MFL?" 40 FOR I= 0 TO 30 50 PRINT @8;"CF",I,"MZ" 60 PRINT @8;"TS TS PS" 70 INPUT @8;MF,ML 80 PRINT "CF = ";I;"MZ", "FREQ = ";MF, "LEVEL = ";ML 90 BEEP 100 NEXT I 110 END </pre>	
<p>Sample program of the PC-24. Read the peak list.</p>	
<pre> 10 ISET IFC:ISET REN 20 PRINT @8;"MND OFF HD0" 30 PRINT @8;"PKLSTON" 40 PRINT @8;"PKLVL10ENT" 50 PRINT @8;"S2" 60 PRINT @8;"SI PKL" 70 *SPOLL 80 POLL 8, S 90 IF (S AND 4) = 0 THEN GOTO *SPOLL 100 PRINT@8;"PKN?" 110 INPUT @8;N 120 PRINT@8;"PEAKLIST?" 130 FOR I= 1 TO N </pre>	<pre> ' ' Header OFF. ' Peak list ON. ' Sorting the data in decreasing order of the level. The number of peak is 10. ' Clear status byte. ' Single sweep. ' Wait sweep end. ' Read the number of peak. ' Read the peak list. </pre>

SPECTRUM ANALYZER
OPERATION MANUAL

11.7 Service Request (SRQ)

	(cont'd)

140 INPUT @8;FREQ, LEVEL	
150 NEXT I	
160 END	

11.8 Setup Example of TV Channel Function (OPT-72)

GPIB code setup example of TV channel function is shown as follows. The sample program uses "N88-BASIC" produced by NEC Corporation.

<p>Example 1: Channel setup I</p> <hr style="border-top: 1px dashed black;"/> <pre> 10 ISET IFC:ISET REN 20 PRINT @8;"TVMD ON" ! Set up channel input mode. 30 PRINT @8;"TVVHF" ! Set up VHF mode. 40 PRINT @8;"CHAUTO" ! Set up channel auto. 50 PRINT @8;"CF TVCH 1ENT" ! Set up picture frequency 1CH. 60 END </pre> <p>(Note) If center frequency/start frequency/stop frequency is set up during channel input mode, it becomes frequency input mode.</p>
<p>Example 2: Channel setup II</p> <hr style="border-top: 1px dashed black;"/> <pre> 10 ISET IFC:ISET REN 20 PRINT @8;"TVMD ON" ! Set up channel input mode. 30 PRINT @8;"TVVHF" ! Set up VHF mode. 40 PRINT @8;"FA TVCH 1ENT" ! Set up the lower limit of frequency bandwidth 1CH. 50 PRINT @8;"FB TVCH 3ENT" ! Set up the upper limit of frequency bandwidth 3CH. 60 END </pre>
<p>Example 3: User table setup</p> <hr style="border-top: 1px dashed black;"/> <pre> 10 ISET IFC:ISET REN 20 PRINT @8;"TVMD ON" ! Set up channel input mode. 30 PRINT @8;"TVUSR" ! Set up USER mode. 40 PRINT @8;"TVTIT/USER TABLE,USR/" ! Set up table title. 50 PRINT @8;"TVEDDEL TVEDIN" ! Delete user table and set input status. 60 PRINT @8;"#1 91.25MZ 90.0MZ 96.0MZ" ! Set up picture frequency and frequency range in 1CH. 70 PRINT @8;"#2 97.25MZ 96.0MZ 102.0MZ" ! Set up picture frequency and frequency range in 2CH. 80 END </pre>
<p>Example 4: User table setup available for channel number input</p> <hr style="border-top: 1px dashed black;"/> <pre> 10 ISET IFC:ISET REN 20 PRINT @8;"TVMD ON" ! Set up channel input mode. 30 PRINT @8;"TVUSR 2" ! Set up USER2 mode. 40 PRINT @8;"TVTIT/USER 2 TABLE,US2" ! Set up table title. 50 PRINT @8;"TVEDDEL TVED IN" ! Delete user table and set input state. 60 PRINT @8;"#120 55MZ 50MZ 60MZ" ! Set up channel number, picture frequency and frequency range. 70 PRINT @8;"#2000 85MZ 800MZ 90MZ" ! Set up channel number, picture frequency and frequency range. 80 END </pre>

11.9 GPIB Command Codes

Note on Table

- An asterisk (*) in the Listener Codes column indicates that you can send numeric data following that code by using a knob, numeric key or step key.
- A plus sign (+) in the Output Formats column indicates that multiple data items are output.
- AUTO/MANUAL or ON/OFF in the Output Formats column indicates that the code outputs 1 or 0, respectively.
- ON/OFF in the Output Formats column indicates that they output 1 or 0, respectively.
- A star (☆) in the Remarks column indicates the initial value when power is turned on.
- All frequencies are in Hertz (Hz), and all times are in seconds or fractions of a second.

Function	Listener code	Talker request			Remarks
		Code	Output format	Header	
Frequency	Center frequency	CENTER *	CENTER?	Frequency	CF
		CF *	CF?	Frequency	CF
	CF Step size	CFSTEP *	CFSTEP?	Frequency	CS
		CS *	CS?	Frequency	CS
	CF Step AUTO	CSAUTO	CSAUTO?	AUTO/MANUAL	-
		CA	CA?	AUTO/MANUAL	-
	Frequency offset size	FROFS *	FROFS?	ON/OFF + Frequency	FO
		FO *	FO?	ON/OFF + Frequency	FO
	Frequency offset ON	FROFS ON *	-	-	-
		FO ON *	-	-	-
		FON *	-	-	-
	Frequency offset OFF	FROFS OFF	-	-	-
		FO OFF	-	-	-
		FOF	-	-	-
	Frequency span	SPAN *	SPAN?	Frequency	SP
		SP *	SP?	Frequency	SP
	Full span	FLSP	-	-	-
		FS	-	-	-
	Zero span	ZROSP	-	-	-
		ZS	-	-	-
Last span	LTSP	-	-	-	

**SPECTRUM ANALYZER
OPERATION MANUAL**

11.9 GPIB Command Codes

(cont'd)

	Function	Listener code	Talker request			Remarks
			Code	Output format	Header	
Frequency	Start frequency	START *	START?	Frequency	FA	
		SRT *	SRT?	Frequency	FA	
		FA *	FA?	Frequency	FA	
		FT *	FT?	Frequency	FA	
	Stop frequency	STOP *	STOP?	Frequency	FB	
		STP *	STP?	Frequency	FB	
		FB *	FB?	Frequency	FB	
		FP *	FP?	Frequency	FB	
Measure 1	HI-SENCE ON	HS ON	-	-	-	
		HS	-	-	-	
	HI-SENCE OFF	HS OFF	-	-	-	
		SHHS	-	-	-	
	Counter	-	COUNT?	OFF/ON	-	
		-	CT?	OFF/ON	-	
		-	CN?	OFF/ON	-	
	Counter ON	COUNT ON	-	-	-	
		CT ON	-	-	-	
		CN ON	-	-	-	
	Resolution : 1kHz	CN0	-	-	-	
	: 100Hz	CN1	-	-	-	
	: 10Hz	CN2	-	-	-	
	: 1Hz	CN3	-	-	-	
	Counter OFF	COUNT OFF	-	-	-	
		CT OFF	-	-	-	
		CN OFF	-	-	-	
		CNF	-	-	-	
	DELAY SWEEP					
	Trigger signal source :					
:VIDEO	VIDEO DLY *	-	-	-		
:EXT	EXT DLY *	-	-	-		
:TV-V	TVV DLY	-	-	-		
:TV-H	TVH DLY	-	-	-		
TV signal						
:NTSC system	TVHNT DLY	-	-	-		
:PAL & SECAM system	TVHPS DLY	-	-	-		

SPECTRUM ANALYZER
OPERATION MANUAL

11.9 GPIB Command Codes

(cont'd)

Function	Listener code	Talker request			Remarks
		Code	Output format	Header	
Measure 1	Picture signal modulation polarity				
	:+	TVPLO DLY +	-	-	-
	:-	TVPLO DLY -	-	-	-
	Trigger slope				
	:+	TRIGSLP DLY +	-	-	-
	:-	TRIGSLP DLY -	-	-	-
	Delay time	DLYPOS *	DLYPOS?	time	DSP
	Delay sweep time	DLYSWPTIM *	DLYSWPTIM?	time	DST
	DELAY SWEEP	-	SLYSWP?	OFF/ON	
	:ON	DLYSWP ON	-	-	-
	:OFF	DLYSWP OFF	-	-	-
	Sweep time	SWP DLY *	-	-	-
	Delay mode OFF	DLY OFF	-	-	-
	Gated sweep				
	Gate signal		GTSG?	1 : External 0 : Internal	-
	External	GTSGE	-	-	-
	Internal	GTSGI	-	-	-
	Gate position	GTPOS	GTPOS?	Real value	GSP
Gate width	GTWID	GTWID?	Real value	GSW	
Time axis sweep time	SWP GT	-	-	-	
Gated SWP		GTSWP?	1/0	-	
ON	GTSWO ON	-	-	-	
OFF	GTSWP OFF	-	-	-	
Gated mode OFF	GTOFF	-	-	-	
Peak list		PKLST?	OFF/ON		
ON	PKLSTON	-	-	-	
OFF	PKLSTOFF	-	-	-	
Single sweep	SI PKL	-	-	-	
Peak ΔY div	DY PKL *	-	-	-	

**SPECTRUM ANALYZER
OPERATION MANUAL**

11.9 GPIB Command Codes

(cont'd)

	Function	Listener code	Talker request			Remarks
			Code	Output format	Header	
Measure 1	Peak range					
	Normal	PSN PKL	-	-	-	
	Upper	PSU PKL	-	-	-	
	Lower	PSL PKL	-	-	-	
	Peak mode	-	PKMD?	0 : Frequency 1 : Level	-	
	In order of frequency	PKFREQ				
	In order of level	PKLVL *	PKLVL?	Integer (Number of peaks set)	PKL	
	Number of peaks detected		PKL?	Integer	PKL	
	Data output		PEAKLIST?	Frequency + Level	Same as MF, ML	
Measure 2	OBW	OBW *	OBW?	Percentage + operation value	OBW, MF	See Note.
	ACP	ADJ	ADJ?	Operation value	Same as ML	See Note.
	ACP GRAPH	ADG	-	-	-	
	ACP GRAPH OFF	ADG OFF	-	-	-	
	ACP Ch Space	ADCH *	ADCH ?	Frequency	ADC	
	ACP Specified BW	ADBS *	ADBS ?	Frequency	ADB	
	dB down					
	X dB down width	MKBW *	MKBW?	Level	XDB	
	X dB down	DBDOWN	-	-	-	
		XDB	-	-	-	
	X dB down left	DBLEFT	-	-	-	
		XDL	-	-	-	
	X dB down right	DBRIGHT	-	-	-	
		XDR	-	-	-	
	X dB relative	DBREL	-	-	-	
		DC0	-	-	-	
X dB abs. left	DBABSL	-	-	-		
	DC1	-	-	-		
X dB abs. right	DBABSR	-	-	-		
	DC2	-	-	-		
X dB execution state	-	DC?	0 : Relative 1 : Absolute (Left) 2 : Absolute (Right)	-		

Note: Two calculated results are output continuously.
 IF OBW: Frequency + Frequency
 IF ACP : Level + Level

**SPECTRUM ANALYZER
OPERATION MANUAL**

11.9 GPIB Command Codes

(cont'd)

Function	Listener code	Talker request			Remarks
		Code	Output format	Header	
Continuously dB down?	-	CDB?	OFF/ON	-	
Continuously dB down ON	CDB ON	-	-	-	
Continuously dB down OFF	CDB OFF	-	-	-	
3rd Order Meas	PKTHIRD	-	-	-	
AM modulation ratio (%AM)	AMMOD	AMMOD?	Operation value	-	
Measure 2					
Power measurement					
Average count	PWTM *	PWTM?	Integer (1 to 999)	-	
Average power ON	PWAVG ON	-	-	-	
Average power OFF	PWAVG OFF	-	-	Unit : Header	
Average power?		PWAVG?	Level	dBm : PWB	
Total power ON	PWTOTAL ON	-	-	dBmV : PWM	
Total power OFF	PWTOTAL OFF	-	-	dBuV : PWU	
Total power?		PWTOTAL?	Level	dBuVemf : PWE	
Channel power ON	PWCH ON	-	-	dBpW : PWP	
Channel poer OFF	PWCH OFF	-	-	V : PWV	
Channel power?		PWCH?	Level	W : PWW	
Carrier power ON	PWCARR	-	-	-	
Position of displaying measurement result					
Upper	PDU	-	-	-	
Lower	PDL	-	-	-	
Reference Level					
Reference level	REF *	REF?	Level	Unit : Header	
	RE *	RE?	Level	dBm : REB	
	RL *	RL?	Level	dBmV : REM	
				dB μ V : REU	
				dB μ Vemf	
				: REE	
				dBpW : REP	
				V : REV	
				W : REW	
X dB/div	DIV *	DIV?	0: 10 (20) dB/ 1: 5 (10) dB/ 2: 2 (4)dB/ 3: 1 (2) dB/ When the peak list is ON, the number inside the parentheses is valid.	-	
	DD *	DD?		-	
LINEAR	LIN	-	-	-	
	LN	-	-	-	
	LL	-	-	-	

SPECTRUM ANALYZER
OPERATION MANUAL

11.9 GPIB Command Codes

(cont'd)

Function	Listener code	Talker request			Remarks	
		Code	Output format	Header		
Reference Level	Reference level display unit	-	UNIT?	0: dBm	-	
		-	UN?	1: dBmV	-	
		-	AUNITS?	2: dB μ V	-	
				3: dB μ Vemf		
				4: dBpW		
				6: V		
				7: W		
	dBm	UDBM	-	-	-	
		AUNITS DBM	-	-	-	
		KSA	-	-	-	
		UB	-	-	-	
	dBmV	UDBMV	-	-	-	
		AUNITS DBMV	-	-	-	
		KSB	-	-	-	
		UM	-	-	-	
	dB μ V	UDBUV	-	-	-	
		AUNITS DBUV	-	-	-	
		KSC	-	-	-	
		UU	-	-	-	
	dB μ Vemf	UEMF	-	-	-	
		UE	-	-	-	
	dBpW	UDBPW	-	-	-	
		UW	-	-	-	
	volts	UVLT	-	-	-	
	AUNITS V	-	-	-		
	KSD	-	-	-		
watts	UWAT	-	-	-		
	AUNITS W	-	-	-		
Level offset	REFOFS *	REFOFS?	OFF/ON + Level	RO		
	RO *	RO?	OFF/ON + Level	RO		
Level offset ON	REFOFS ON*	-	-	-		
	RO ON *	-	-	-		
	RON *	-	-	-		
Level offset OFF	REFOFS OFF	-	-	-		
	RO OFF	-	-	-		
	ROF	-	-	-		

**SPECTRUM ANALYZER
OPERATION MANUAL**

11.9 GPIB Command Codes

(cont'd)

Function	Listener code	Talker request			Remarks
		Code	Output format	Header	
Coupled function					
RBW	RBW *	RBW?	Frequency	RB	
	RB *	RB?	Frequency	RB	
RBW AUTO	RBAUTO	RBAUTO?	AUTO/MANUAL	-	
	BA	BA?	AUTO/MANUAL	-	
VBW	VBW *	VBW?	Frequency	VB	
	VB *	VB?	Frequency	VB	
VBW AUTO	VBAUTO	VBAUTO?	AUTO/MANUAL	-	
	VA	VA?	AUTO/MANUAL	-	
SWP	SWP *	SWP?	Time	SW	
	SW *	SW?	Time	SW	
	ST *	ST?	Time	SW	
	SWP AUTO	SWAUTO?	AUTO/MANUAL	-	
	AS	AS?	AUTO/MANUAL	-	
WIDE RBW	-	WRBW?	OFF/ON	-	
ON	WRBW ON	-	-	-	
OFF	WRBW OFF	-	-	-	
ATT	ATT *	ATT?	Level	AT	
	AT *	AT?	Level	AT	
	ATT AUTO	ATAUTO?	AUTO/MANUAL	-	
Couple All AUTO	AA	AA?	AUTO/MANUAL	-	
	COALL	COALL?	AUTO/MANUAL	-	
AL	AL	AL?	AUTO/MANUAL	-	
Menu					
Trigger mode	-	TRMD?	0: FREE RUN	-	
	-	TM?	2: VIDEO 3: TV_V 4: TV_H 5: External	-	
FREE RUN	FREE	-	-	-	
	TM FREE	-	-	-	
	FR	-	-	-	
VIDEO	VIDEO *	VIDEO?	Integer	VID	
	VI *	VI?	Integer	VID	
TV_V	TVV	-	-	-	
	TV	-	-	-	
TV_H	TVH *	TVH?	Integer	TVH	

**SPECTRUM ANALYZER
OPERATION MANUAL**

11.9 GPIB Command Codes

(cont'd)

Function	Listener code	Talker request			Remarks
		Code	Output format	Header	
TV Signal					
NTSC method	TVHNT	-	-	-	
PAL & SECAM method	TVHPS	-	-	-	
Video signal modulation					
polarity	+ TVPOL +	-	-	-	
	- TVPOL -	-	-	-	
External	EXT *	EXT?	Real value (0 to 5.0)	EXT	
	TM EXT *	-	-	-	
	EX *	EX?	Real value (0 to 5.0)	EXT	
Trigger slope	+ TRIGSLP +	-	-	-	
	- TRIGSLP -	-	-	-	
Trigger position	TRPOSI	TRPOSI?	Integer	TRP	
Detector mode	-	DTMD?	0: Normal	-	
	-	DM?	1: Positive	-	
	-	DET?	2: Negative	-	
			3: Sample	-	
Menu	Normal	DTN	-	-	
		DET NRM	-	-	
		KSa	-	-	
	Positive	DTP	-	-	
		DET POS	-	-	
		KSb	-	-	
	Negative	DTG	-	-	
		DET NEG	-	-	
		KSd	-	-	
	Sample	DTS	-	-	
		DET SMP	-	-	
		KSe	-	-	
Sweep mode	-	SWMD?	0 : Continuous & full	-	
	-	SWM?	1 : Continuous & window	-	
			10 : Manual & full		
			11 : Manual & window		
			20 : Single & full		
			21 : Single & window		
Continuous	CONTS	-	-	-	
	SN	-	-	-	
Manual	MANSWP	-	-	-	
	SM	-	-	-	

**SPECTRUM ANALYZER
OPERATION MANUAL**

11.9 GPIB Command Codes

(cont'd)

Function	Listener code	Talker request			Remarks	
		Code	Output format	Header		
Single	SNGLS	-	-	-		
	SI	-	-	-		
	Window ON	WDOSWP ON	-	-	-	
		SDW	-	-	-	
	Window OFF	WDOSWP OFF	-	-	-	
	Reset & Start	SR	-	-	-	
	Take sweep	TS	-	-	-	
	Pause time	PAUSE *	PAUSE?	OFF /ON + Time	PU	
		PU *	PU?	OFF /ON + Time	PU	
	Marker pause ON	PAUSE ON *	-	-	-	
		PU ON *	-	-	-	
		PUN *	-	-	-	
	Marker pause OFF	PAUSE OFF	-	-	-	
		PU OFF	-	-	-	
		PUF	-	-	-	
Menu	Sound mode	-	SDMD?	0: OFF		
		-	SD?	1: ON (AM) 2: ON (FM)		
	Sound ON (AM or FM)	SON	-	-	-	
	Sound ON (AM)	SD AM	-	-	-	
		SAM	-	-	-	
	Sound ON (FM)	SD FM	-	-	-	
		SFM	-	-	-	
	Sound OFF	SD OFF	-	-	-	
		SOF	-	-	-	
	Display line	DL *	DL ?	OFF/ON + Level	Unit : Header	
				dBm : DLB		
				dBmV : DLM		
				dB _μ V : DLU		
				dB _μ Vemf : DLE		
			dBpW : DLP			
			V : DLV			
			W : DLW			
Display line ON	DL ON *	-	-	-		
	DLN *	-	-	-		
Display line OFF	DL OFF	-	-	-		
	DLF	-	-	-		

**SPECTRUM ANALYZER
OPERATION MANUAL**

11.9 GPIB Command Codes

(cont'd)

Function	Listener code	Talker request			Remarks
		Code	Output format	Header	
Trace A	-	TA?	(Lower byte) 0: write 1: view 2: blank 3: normalize 4: A-DL→A 5: A-B→A 6: B-A→A (Upper byte) 1: + max hold 2: + averaging	-	
A write	AWRITE	-	-	-	
	AW	-	-	-	
A view	AVIEW	-	-	-	
	AV	-	-	-	
A blank	ABLANK	-	-	-	
	AB	-	-	-	
A max hold	AMAX	-	-	-	
	AM	-	-	-	
A min hold	AMIN	-	-	-	
A averaging	AAVG *	AAVG?	Integer	AG	
	AG *	AG?	Integer	AG	
start	AGR	-	-	-	
stop	AGS	-	-	-	
pause	AGP	-	-	-	
continue	AGC	-	-	-	
1 time	AG1	-	-	-	
continue	AG0	-	-	-	
Detector mode					
Sample	AGSMP	-	-	-	
Positive	AGPOS	-	-	-	
A Normalize					
A Normalize ON	ANORM	-	-	-	
	AN	-	-	-	
	ANORM ON	-	-	-	
	AN ON	-	-	-	
	ANN	-	-	-	
A Normalize OFF	ANORM OFF	-	-	-	
	AN OFF	-	-	-	
	ANF	-	-	-	

**SPECTRUM ANALYZER
OPERATION MANUAL**

11.9 GPIB Command Codes

(cont'd)

	Function	Listener code	Talker request			Remarks
			Code	Output format	Header	
Trace	Correction data save	AR	-	-	-	
	A Instant normalize	AI	-	-	-	
		SHTA	-	-	-	
	Correction data selection					
	BKUP	ANBK	-	-	-	
	MEM	ANM	-	-	-	
	A XCH B	ACHB	-	-	-	
		CH	-	-	-	
	A-B→A	ABA	-	-	-	
		TR0	-	-	-	
	B-A→A	BAA	-	-	-	
		TR1	-	-	-	
	A-DL→A	ADLA	-	-	-	
		TR2	-	-	-	
	Trace A clear	CWA	-	-	-	
	Trace B	-	TB?	(Lower byte) 0 : write 1 : view 2 : blank	-	
B store	BSTORE	-	-	-		
B write	BWRITE	-	-	-		
	BW	-	-	-		
B view	BVIEW	-	-	-		
	BV	-	-	-		
B blank	BBLANK	-	-	-		
	BB	-	-	-		
GPIB	Local	LOCAL	-	-	-	
		LC	-	-	-	
	GPIB Address	-	AD?	Integer	AD	
	-	SHLC?	Integer	AD		
User Definition	User definition					
	1	UR1	-	-	-	
	2	UR2	-	-	-	
	3	UR3	-	-	-	
	4	UR4	-	-	-	
	5	UR5	-	-	-	
	6	UR6	-	-	-	

SPECTRUM ANALYZER
OPERATION MANUAL

11.9 GPIB Command Codes

(cont'd)

	Function	Listener code	Talker request			Remarks
			Code	Output format	Header	
Recall	Recall	RECALL *	-	-	-	See Note.
		RC *	-	-	-	
		RCNORM *	-	-	-	
		RN *	-	-	-	
Save	Save	SAVE *	-	-	-	See Note.
		SV *	-	-	-	
		SHRC *	-	-	-	
	Current drive A	CDRA	-	-	-	
	Current drive B	CDRB	-	-	-	
Preset	Instrument preset	IP	-	-	-	
Marker	Marker ON	MKR ON *	MKR?	0: Marker off	-	
		MN *	MN?	1: Normal marker	-	
		MKN *	-	2: ΔMarker	-	
	Marker frequency	-	MF?	-	MF	
	Marker level	-	ML?	-	Unit : Header	
					dB : MLD	
					dBm : MLB	
					dBmV : MLM	
					dB _μ V : MLU	
					dB _μ Vemf : MLE	
				dBpW : MLP		
				V : MLV		
				W : MLW		
				dBm/Hz : MLH		
				dB _μ V/√Hz : MLL		
				dBc/Hz : MLC		
	Frequency + Level	-	MFL?	Frequency + Level	Same as MF, ML	
	Normal marker	MKNORM *	MKNORM?	Frequency	MF	
		MKN *	-	-	-	
		MK *	MK?	Frequency	MF	

Note : When recalling or saving data, input the characters using a slash(/) immediately before and after the listener code. Up to 8 characters are available.

For example, input "RECALL /A:FILE0001/" when recalling the data.

**SPECTRUM ANALYZER
OPERATION MANUAL**

11.9 GPIB Command Codes

(cont'd)

Function	Listener code	Talker request			Remarks	
		Code	Output format	Header		
Marker	ΔMarker	MKDLT *	MKDLT?	Frequency	MF	
		MKD *	-	-	-	
		MT *	MT?	Frequency	MF	
	Fixed Marker	-	FIX?	OFF/ON	-	
			FX?	OFF/ON	-	
	Fixed Marker ON	FIX ON	-	-	-	
		FX ON	-	-	-	
		FXN	-	-	-	
	Fixed Marker OFF	FIX OFF	-	-	-	
		FX OFF	-	-	-	
		FXF	-	-	-	
	1/ΔMarker		REDLT?	OFF/ON + Operation value	MF	See Note.
	1/ΔMarker ON	REDLT ON	-	-	-	
	1/ΔMarker OFF	REDLT OFF	-	-	-	
	ΔMarker %display	ON	MKDPR ON	-	-	-
OFF		MKDPR OFF	-	-	-	
Multi-Marker						
Multi-marker ON	MLT	MLT?	OFF/ON	-		
Multi-Marker OFF	MO					
Active marker move	MN *	-	-	-	*Frequency	
	MK *	-	-	-		
Multi-Marker No. 1	ON	MLN1 *	-	-	-	
	OFF	MLF1	-	-	-	
Multi-Marker No. 2	ON	MLN2 *	-	-	-	
	OFF	MLF2	-	-	-	
Multi-Marker No. 3	ON	MLN3 *	-	-	-	
	OFF	MLF3	-	-	-	
Multi-Marker No. 4	ON	MLN4 *	-	-	-	
	OFF	MLF4	-	-	-	
Multi-Marker No. 5	ON	MLN5 *	-	-	-	
	OFF	MLF5	-	-	-	
Multi-Marker No. 6	ON	MLN6 *	-	-	-	
	OFF	MLF6	-	-	-	

Note : Calculated value is used as time or frequency data.

**SPECTRUM ANALYZER
OPERATION MANUAL**

11.9 GPIB Command Codes

(cont'd)

Function	Listener code	Talker request			Remarks	
		Code	Output format	Header		
Active marker Frequency		MF?	Frequency	MF		
Active marker Level		ML?	Level	Same as the marker level		
Active marker Frequency + Level		MFL?	Frequency + level	Same as MF and ML		
Multi-Marker All frequencies		MLSF?	Frequency	MF	6 markers + ΔMKR	
Multi-Marker All levels		MLSL?	Level	Same as ML	6 markers + ΔMKR	
Multi-Marker Peak list						
In frequency order	PLS FREQ	-	-	-		
In level order	PLS LVL	-	-	-		
No. of peaks	-	MPKN?	Integer	MPN		
Marker	Signal track	-	SIG?	OFF/ON	-	
		-	SG?	OFF/ON	-	
	Signal track ON	SIG ON	-	-	-	
		SG ON	-	-	-	
		SGN	-	-	-	
	Signal track OFF	SIG OFF	-	-	-	
		SG OFF	-	-	-	
		SGF	-	-	-	
	Noise/Hz	NOISE *	NOISE?	0: OFF + Frequency	NI	
		NI *	NI?	1: dBm + Frequency	NI	
			2: dB _μ V + Frequency			
			3: dBc + Frequency			
dBm/Hz ON	NIDBM	-	-	-		
	NIM	-	-	-		
dB _μ V / √Hz ON	NIDBU	-	-	-		
	NIU	-	-	-		
dBc/Hz ON	NIDBC	-	-	-		
	NIC	-	-	-		
Noise/Hz OFF	NOISE OFF	-	-	-		
	NI OFF	-	-	-		
	NIF	-	-	-		

Note : Calculated value is used as time or frequency data.

**SPECTRUM ANALYZER
OPERATION MANUAL**

11.9 GPIB Command Codes

(cont'd)

	Function	Listener code	Talker request			Remarks
			Code	Output format	Header	
Marker	Marker display					
	Relative value display	HDR	-	-	-	
	Absolute value display	HDA	-	-	-	
	Active marker movement					
	Trace A	MKTRACE TRA	MKTRACE?	0: Blank	-	
	Trace B	MKTRACE TRB	-	1: Trace A 2: Trace B	-	
	Marker OFF	MKR OFF	-	-	-	
		MKOFF	-	-	-	
		MO	-	-	-	
		MF	-	-	-	
Peak Search	Peak Search	PEAK	-	-	-	
		MKPK	-	-	-	
		MKPK HI	-	-	-	
		PS	-	-	-	
	NEXT peak	NXPEAK	-	-	-	
		MKPK NH	-	-	-	
		NXP	-	-	-	
	NEXT peak left	NXLEFT	-	-	-	
		MKPK NL	-	-	-	
		NXL	-	-	-	
	NEXT peak right	NXRIGHT	-	-	-	
		MKPK NR	-	-	-	
		NXR	-	-	-	
	MIN search	MIN	-	-	-	
		MIS	-	-	-	
	NEXT MIN	NXMIN	-	-	-	
		NXM	-	-	-	
	Continuously peak					
	Continuously peak ?	-	CP?	ON/OFF	-	
	Continuously peak ON	CP ON	-	-	-	
	CPN	-	-	-		
Continuously peak OFF	CP OFF	-	-	-		
	CPF	-	-	-		
Peak range						
Normal	PSN	-	-	-		
Upper side	PSU	-	-	-		
Lower side	PSL	-	-	-		
Peak ΔY div	DY*	DY?	Real value (0.1 to 10)	DY		

SPECTRUM ANALYZER
OPERATION MANUAL

11.9 GPIB Command Codes

(cont'd)

Function	Listener code	Talker request			Remarks
		Code	Output format	Header	
MKR→					
MKR→CF	MKCF MC	- -	- -	- -	
MKR→REF	MKRL MR	- -	- -	- -	
MKR Δ→SPAN	MTSP DS	- -	- -	- -	
MKR→CF step	MKCS M0	- -	- -	- -	
MKR Δ→CF step	MTCS M1	- -	- -	- -	
MKR Δ→CF	MTCF	-	-	-	
MKR →MKR step	MKMKS M2	- -	- -	- -	
MKR Δ→MKR step	MTMKS M3	- -	- -	- -	
MKR step size	MKS * MPM *	MKS? MPM?	Frequency Frequency	MKS MKS	
MKR step AUTO	MKSAUTO MPA	MKSAUTO? MPA?	AUTO/MANUAL AUTO/MANUAL	- -	

MKR→

**SPECTRUM ANALYZER
OPERATION MANUAL**

11.9 GPIB Command Codes

(cont'd)

Function	Listener code	Talker request			Remarks	
		Code	Output format	Header		
Measurement Window	Measurement window	-	WDO?	OFF/ON	-	
		-	SHO?	OFF/ON	-	
		-	WN?	OFF/ON	-	
	Window ON	WDO ON WN	- -	- -	- -	
	Window OFF	WDO OFF WF	- -	- -	- -	
	Center position : X	WDOLX * WLX *	WDOLX? WLX?	Frequency Frequency	WLX WLX	
	Center position : Y	WDOLY * WLY *	WDOLY? WLY?	Level Level	WLY WLY	See Note.
	Window width	WDODX * WDX *	WDODX? WDX?	Frequency Frequency	WDX WDX	
	Window height	WDODY * WDY *	WDODY? WDY?	Level Level	WDY WDY	See Note.
	Start frequency	WDOSRT * WTF *	WDOSRT? WTF?	Frequency Frequency	WTF WTF	
	End frequency	WDOSTP * WPF *	WDOSTP? WPF?	Frequency Frequency	WPF WPF	
	Upper level	WDOUP * WUL *	WDOUP? WUL?	Level Level	WUL WUL	
	Lower level	WDOLOW * WLL *	WDOLOW? WLL?	Level Level	WLL WLL	
	GO/NG Judgment	-	CM?	NG : 0 OK : 1	-	

Note : The center frequency position = Y and the measurement window height can be input using the step keys and the data knob only.

SPECTRUM ANALYZER
OPERATION MANUAL

11.9 GPIB Command Codes

(cont'd)

Function	Listener code	Talker request			Remarks
		Code	Output format	Header	
Calibration					
CALL ALL	CLALL	-	-	-	
	CLA	-	-	-	
Total gain cal.	CLTOTAL	-	-	-	
	CLG	-	-	-	
Input ATT cal.	CLATT	-	-	-	
	IT0	-	-	-	
IF step AMP cal.	CLSTEP	-	-	-	
	IT1	-	-	-	
RBW switch cal.	CLRBW	-	-	-	
	IT2	-	-	-	
Log linearity cal	CLLOG	-	-	-	
	IT3	-	-	-	
AMPTD MAG cal.	CLMAG	-	-	-	
	IT4	-	-	-	
PBW cal.	CLPBW	-	-	-	
	IT6	-	-	-	
Calibration signal	ON CLN*	CL?	Level	Unit : Header	
				dBm : CLB	
				dBmV : CLM	
				dB μ V : CLU	
				dB μ Vemf	
				: CLE	
				dBpW : CLP	
				V : CLV	
				w : CLW	
	OFF CLF	-	-	-	

**SPECTRUM ANALYZER
OPERATION MANUAL**

11.9 GPIB Command Codes

(cont'd)

	Function	Listener code	Talker request			Remarks
			Code	Output format	Header	
Calibration	f compensation	-	FRCORR?	OFF/ON	-	
		-	FC?	OFF/ON	-	
	f compensation ON	FRCORR ON	-	-	-	
		FC ON	-	-	-	
		FCN	-	-	-	
	f compensation OFF	FRCORR OFF	-	-	-	
		FC OFF	-	-	-	
		FCF	-	-	-	
	CAL compensation	-	CLCORR?	OFF/ON	-	
		-	CC?	OFF/ON	-	
	CAL compensation ON	CLCORR ON	-	-	-	
		CC ON	-	-	-	
		CCN	-	-	-	
	CAL compensation OFF	CLCORR OFF	-	-	-	
	CC OFF	-	-	-		
	CCF	-	-	-		
Copy	Printer output					
	High resolution	PRNT HIGH	-	-	-	
	Low resolution	PRNT LOW	-	-	-	
	Large size (Low resolution)	PSIZE LRG	-	-	-	
	Small size (High resolution)	PSIZE SML	-	-	-	
	PCL printer	PCMND PCL	-	-	-	
	ESC/P printer	PCMND ESC	-	-	-	
	Plotter output execution	PLOT	-	-	-	
		PLT	-	-	-	
	Printer output execution	PRINT	-	-	-	
	PRT	-	-	-		
Memory card output execution						
Drive A	MCPA	-	-	-		
Drive B	MCPB	-	-	-		
Configure	Plotter type					
	R9833	PLTYPEA	-	-	-	Note
	HP7470	PLTYPEB	-	-	-	
	HP7475	PLTYPEC	-	-	-	
	HP7440	PLTYPED	-	-	-	
	PLTYPEE	-	-	-		

Note: The 682-XA provided by Hitachi Electronics Ltd is the same code as R9833's code.

**SPECTRUM ANALYZER
OPERATION MANUAL**

11.9 GPIB Command Codes

(cont'd)

Function	Listener code	Talker request			Remarks	
		Code	Output format	Header		
Configure	Plotter data					
	All data	PLALL	-	-	-	
	Waveform only	PLTRACE	-	-	-	
	Character only	PLCHAR	-	-	-	
	Graphic only	PLGRAT	-	-	-	
	Marker, DL, WDO	PLMKR	-	-	-	
	Antenna table	PLANT	-	-	-	
	Limit 1 table	PLLMTA	-	-	-	
	Limit 2 table	PLLMTB	-	-	-	
	Plotter paper					
	A4	PLA4	-	-	-	
	A3	PLA3	-	-	-	
	Plotter division size					
	1 division	PLPIC1	-	-	-	
	2 division	PLPIC2	-	-	-	
4 division	PLPIC4	-	-	-		
Plotter printing position						
Center	PLMID	-	-	-		
Left	PLLEFT	-	-	-		
Right	PLRIGHT	-	-	-		
Upper left	PLUPLEFT	-	-	-		
Upper Right	PLUPRIGHT	-	-	-		
Lower left	PLLOWLEFT	-	-	-		
Lower right	PLLOWRIGHT	-	-	-		
Number of plotter pen						
Pen 1	PLPEN1	-	-	-		
Pen 2	PLPEN2	-	-	-		
Pen 4	PLPEN4	-	-	-		
Pen 6	PLPEN6	-	-	-		
Pen 8	PLPEN8	-	-	-		
Plotter printing position movement						
Auto	PLAUTO	-	-	-		
Manual	PLMAN	-	-	-		
Memory card output						
File number	MCPN *	-	-	-		
Automatic file update						
ON	MCPINC ON	-	-	-		
OFF	MCPINC OFF	-	-	-		
Bitmap data						
Monochrome bitmap data	MCPNORM	-	-	-		
Invert monochrome bitmap data	MCPINV	-	-	-		

**SPECTRUM ANALYZER
OPERATION MANUAL**

11.9 GPIB Command Codes

(cont'd)

	Function	Listener code	Talker request			Remarks
			Code	Output format	Header	
Configure	10MHz reference signal source					
	Internal	RFI	-	-	-	
	External	RFE	-	-	-	
	Internal high-stable reference oscillator	RFOP	-	-	-	
	OVEN COLD check	-	RFOPC?	1: OVEN COLD executing 2: End of OVEN COLD	- -	
Utility	RS-232					
	Xon/Xoff Output ON (or Output is valid.)	PRTCL RMT	-	-	-	
	Output OFF (or Output is not valid.)	PRTCL CPY	-	-	-	
	Antenna type	-	ANT?	0: OFF 1: Dipole 2: Log Periodic	-	
Utility	Antenna selection					
	Die poll	ANT0	-	-	-	
	Log Peri	AN0	-	-	-	
	Antenna OFF	ANT1	-	-	-	
	Antenna OFF	AN1	-	-	-	
	Antenna OFF	AF	-	-	-	
	Antenna OFF	ANT OFF	-	-	-	
	Correction table	-	CR?	OFF/ON	-	
	Correction table ON	CR ON	-	-	-	
	Correction table OFF	CRN	-	-	-	
	Correction table OFF	CR OFF	-	-	-	
	Correction table input	CRF	-	-	-	
	Correction table deletion	CRIN *	-	-	-	
	Correction table deletion	CRDEL	-	-	-	
	Correction	-	CORR?	OFF/ON	-	
Correction ON	CORR ON	-	-	-		
Correction OFF	CORR OFF	-	-	-		
Correction mode Antenna	CR ANT	-	-	-		
Level	CR LVL	-	-	-		
PASS/FAIL judgment						
Trace A	PFJ A	PFJ?	0: FAIL 1: PASS	- -		
Continuous PASS/FAIL ON	PFC ON	PFC?	0: OFF	-		
Continuous PASS/FAIL OFF	PFC OFF		1: ON	-		

SPECTRUM ANALYZER
OPERATION MANUAL

11.9 GPIB Command Codes

(cont'd)

Function	Listener code	Talker request			Remarks
		Code	Output format	Header	
Judgment result	-	OPF?	0: PASS 1: UPPER FAIL 2: LOWER FAIL 3: UPPER & LOWER FAIL	-	
Upper FAIL point	-	FPU?	2 bytes + 2 bytes X pic.	-	
Lower FAIL point	-	FPL?	2 bytes + 2 bytes X pic.	-	
Limit line type selection	-	LIMTYPE?	0: FREQ 1: TIME	-	
Limit line type selection					
Frequency domain	LIMTYP FREQ	-	-	-	
Time domain	LIMTYP TIME	-	-	-	
Limit line					
Frequency or time					
ABS/REL?		LIMPOS?	0: ABS 1: REL	-	
ABS	LIMPOS ABS	-	-	-	
REL	LIMPOS REL	-	-	-	
Limit line level					
ABS/REL?	-	LIMAPOS?	0: ABS 1: REL	-	
ABS	LIMAPOS ABS	-	-	-	
REL	LIMAPOS REL	-	-	-	
Limit line 1	-	LMTA?	OFF/ON	-	
Limit line 1 ON	LMTA ON	-	-	-	
	LAN	-	-	-	
Limit line 1 OFF	LMTA OFF	-	-	-	
	LAF	-	-	-	
Limit line 1 table input	LMTAIN *	-	-	-	
Limit line 1 table deletion	LMTADEL	-	-	-	
Limit line 2	-	LMTB?	OFF/ON	-	
Limit line 2 ON	LMTB ON	-	-	-	
	LBN	-	-	-	
Limit line 2 OFF	LMTB OFF	-	-	-	
	LBF	-	-	-	
Limit line 2 table input	LMTBIN *	-	-	-	
Limit line 2 table deletion	LMTBDEL	-	-	-	

Utility

SPECTRUM ANALYZER
OPERATION MANUAL

11.9 GPIB Command Codes

(cont'd)

	Function	Listener code	Talker request			Remarks
			Code	Output format	Header	
Memory Card	Memory card initialization	MCINIT *	-	-	-	
	Copy	MMI *	-	-	-	
	ALL copy	COPY *	-	-	-	
		ALLCOPY *	-	-	-	
Label	Label	-	LB?	Character string	-	Max.25 characters
		-	SH9?	Character string	-	
	Label input	LB ON/***/	-	-	-	Enclose a character with a slash (/).
		LON/***/	-	-	-	
	Label deletion	LB OFF	-	-	-	
		LOF	-	-	-	
Label display						
	ON	LBDSP ON	-	-	-	
	OFF	LBDSP OFF	-	-	-	
Softkey	Softkey					
	Softkey No.1	SF1	-	-	-	
	Softkey No.2	SF2	-	-	-	
	Softkey No.3	SF3	-	-	-	
	Softkey No.4	SF4	-	-	-	
	Softkey No.5	SF5	-	-	-	
	Softkey No.6	SF6	-	-	-	
	Data input correspondence					
	0 to 9	0 to 9	-	-	-	
	. (decimal point)	.	-	-	-	
	BK SP	BS	-	-	-	
	↓ (step down)	UP	-	-	-	
	↑ (step up)	DN	-	-	-	
	Knob up (coarse)	CU	-	-	-	
	(fine)	FU	-	-	-	
	Knob down (coarse)	CD	-	-	-	
	(fine)	FD	-	-	-	
	-	-	-	-	-	
	GHz	GZ	-	-	-	
	MHz	MZ	-	-	-	
kHz	KZ	-	-	-		
mV	MV	-	-	-		
mW	MW	-	-	-		
dB correspondence	DB	-	-	-		

SPECTRUM ANALYZER
OPERATION MANUAL

11.9 GPIB Command Codes

(cont'd)

	Function	Listener code	Talker request			Remarks
			Code	Output format	Header	
Softkey	mA	MA	-	-	-	
	Second	SC	-	-	-	
	Milli second	MS	-	-	-	
	Micro second	US	-	-	-	
	ENTER	ENT	-	-	-	
Trace Data	Trace data I/O	-	TP?	0: 0 to 340 mode 1: 0 to 2720 mode	-	
	Accuracy					
	341 points	TPC	-	-	-	
	2721 points	TPF	-	-	-	
	Memory A output (ASCII)	-	TAA?	4 bytes + delimiter	-	1 point
	(BINARY)	-	TBA?	2 bytes × 700 points	-	EOI signal
	Memory B output (ASCII)	-	TAB?	4 bytes + delimiter	-	1 point
	(BINARY)	-	TBB?	2 bytes × 700 points	-	EOI signal
	Memory A input (ASCII)	TAA	-	-	-	1 point
	(BINARY)	TBA	-	-	-	EOI signal
Memory B input (ASCII)	TAB	-	-	-	1 point	
(BINARY)	TBB	-	-	-	EOI sig	
TV Channel	TV MODE		TVMD?	ON/OFF	-	
	ON	TVMD ON				
	OFF	TVMD OFF				
	TV BAND		TVBND?	0:VHF 1:UHF 2:CATV 3:BS 4:CS 5:USER 6:USER 2	- - - - - -	
		TVVHF	-	-	-	
		TVUHF	-	-	-	
		TVCATV	-	-	-	
		TVBS	-	-	-	
		TVCS	-	-	-	
		TVUSR	-	-	-	
	TVUSR2	-	-	-		

**SPECTRUM ANALYZER
OPERATION MANUAL**

11.9 GPIB Command Codes

	Function	Listener code	Talker request			Remarks
			Code	Output format	Header	
TV Channel	Channel input					
	Center channel	CF TVCH	-	-	-	
	Start channel	FA TVCH	-	-	-	
	Stop channel	FB TVCH	-	-	-	
	Channel auto		CHAUTO?	AUTO/MANUAL	-	
	AUTO	CHAUTO	-	-	-	
	MANUAL	CHMNL	-	-	-	
	Marker channel		MCH?	Integer	VHF UHF CTV BS CS USR	} According to bands
	Table input	TVEDIN	-	-	-	
	Table delete	TVEDDEL	-	-	-	
Title input	TVTIT	-	-	-		
Memory card						
STORE	TVMST	-	-	-		
LOAD	TVMLD	-	-	-		
TV Monitor	PICTURE					
	ON	TVPIC ON	-	-	-	
	OFF	TVPIC OFF	-	-	-	
	VIDEO RF AM/FM					
	AM	TVRFAM	-	-	-	
	FM	TVRFFM	-	-	-	
	COLOR NTSC/PAL					
	NTSC	TVNTSC	-	-	-	
	PAL	TVPAL	-	-	-	
	TVSTD					
	B/G	TVSBG	-	-	-	
	I	TVSI	-	-	-	
	D/K/K1	TVSDKK	-	-	-	
	L/L1	TVSLL	-	-	-	
	M	TVSM	-	-	-	
CARRIER						
NORM	TVCNORM					
INV	TVCINV					
VIDEO INPUT						
INT VID	TVVIV	-	-	-		
EXT VID	TVVEV	-	-	-		

**SPECTRUM ANALYZER
OPERATION MANUAL**

11.9 GPIB Command Codes

(cont'd)

Function	Listener code	Talker request			Remarks	
		Code	Output format	Header		
TV Monitor	BRIGHT	BRIGHT*	-	-	-	
	CONTRAST	CONTRAST*	-	-	-	
	TINT	TINT*	-	-	-	
	HUE NTSC	HUENTSC*	-	-	-	
	READ OUT	READOUT*	-	-	-	
	Tuning level display					
	Preamplifier display					
ON	TVTUNE ON	-	-	-		
OFF	TVTUNE OFF	-	-	-		
Tracking Generator	Tracking generator					
	ON	TG	TG?	ON/OFF	-	
	OFF	TGF	-	-	-	
	Tracking generator output level	TGL*	TGL?	Level	Unit :Header	
					dBm :TGB	
					dBmV :TGM	
					dB μ V :TGU	
				dB μ Vemf :TGE		
				dBpW :TGP		
				V :TGV		
				W :TGW		
Tracking Generator ADJ	-	TGADJ?	AUTO/MANUAL	-		
:AUTO	TGADJA	-	-	-		
:MANUAL	TGADJM*	-	-	-		
Misc						
Misc	Header OFF	HD0	-	-	-	
	ON	HD1	-	-	-	☆
	Delimiter					
	CR LF <EOI>	DL0	-	-	-	
	LF	DL1	-	-	-	
	<EOI>	DL2	-	-	-	
	CR LF	DL3	-	-	-	☆
	LF <EOI>	DL4	-	-	-	
	Service request					
	Interruption ON	S0	-	-	-	
Interruption OFF	S1	-	-	-	☆	
Status clear	S2	-	-	-		
Service request mask	RQS *	RQS?	Decimal corresponding to SRQ bit	-		

**SPECTRUM ANALYZER
OPERATION MANUAL**

11.9 GPIB Command Codes

(cont'd)

Function	Listener code	Talker request			Remarks
		Code	Output format	Header	
Soft menu display	-	MND?	OFF/ON	-	
Soft menu display ON	MND ON	-	-	-	
Soft menu display OFF	MND OFF	-	-	-	
Product type	-	VER?	6 : U3641 7 : U3641N 10 : U3641PHS	- - -	
Misc Product type (character strings)	-	TYPE?	character strings + delimiter	-	
	-	TYP?	character strings + delimiter	-	
	-	REV?	character strings + delimiter	-	
	-	GPL?	35 characters × 2 lines + LABEL; (1 line)	-	
Back light					
ON	BKLG ON	-	-	-	
OFF	BKLG OFF	-	-	-	

**SPECTRUM ANALYZER
OPERATION MANUAL**

Table 11-7 Examples or data entry (GPIB codes with asterisk)

Command example	Description
CF100MZ CS100KZ FON10MZ SP500MZ	Sets center frequency to 100MHz. Sets frequency step size to 100kHz. Turns frequency offset ON and set it to 10MHz. Sets frequency span to 500MHz.
FA100KZ or FT100KZ FB400KZ or FP400KZ RE - 25DB or RL - 25DB DD5DB	Sets start frequency to 100kHz. Sets stop frequencies to 400kHz. Sets reference level to - 25dBm (if units are set to dBm). Sets 5dB/div.
RON30DB RB300KZ VB100KZ SW200MS AT20DB	Turns level offset ON and sets it to 30dB. Sets RBW to 300kHz. Sets VBW to 100kHz. Sets Sweep time to 200msec. Sets Attenuator to 20dB.
PUN100MS DLN87DB MK1.8GZ MT2MZ MN100KZ	Turns Marker pause ON and sets the time to 100msec. Turns the display line ON and sets to 87dB μ V (if units are set to μ dB V). Turns normal marker ON and sets it to 1.8GHz. Turns delta marker ON and sets normal marker 2MHz from it. Sets the active marker(s) at 100kHz.
NOISE50Hz XDB6DB MPM100KZ	Sets noise power noise width to 50Hz. Sets XdB down width to 6dB. (This can be also set by the XDL and XDR commands.) Sets marker step size to 100kHz.
AG200GZ AD8GZ WTF1MZ WPF2MZ	Sets average A to 200 times and executes. (GZ is entry.) Sets the analyzer GPIB address to 8. (GZ is entry.) Sets window start frequency 1MHz. Sets window stop frequency to 2MHz.
WUL - 20DB WLL - 40DB CLN - 25DB SV /A:FILE0001/ RC /A:FILE0001/	Sets window upper level to - 20dBm (if units are set to dBm). Sets window lower level to - 40dBm (if units are set to dBm). Sets CAL level to - 25dBm (if units are set to dBm). Executes save of file name "FILE0001". Executes recall of file name "FILE0001".

12. IN OCCURRENCE OF A TROUBLE

In case there should be any trouble with the analyzer this chapter presents some ideas for diagnosis and solutions.

In the unlikely event that a problem should arise, please go through this check list first. If the problem still cannot be resolved then contact your nearest dealer or sales and support office. You will find address and telephone numbers at the end of this manual. Please note that you will be charged for any repair work necessary, including anything in the check list here.

Symptom	Possible Cause	Solution
The analyzer cannot be powered up.	The battery, AC/DC Adapter and or the DC power supply cable is not making good contact with the analyzer.	Turn off the power supply and reconnect carefully.
	The AC Adapter power switch is not turned On.	Turn on the Adapter power switch and check that the green LED comes on.
	AC Adapter is defective.	Check whether or not operation is possible with an external DC supply or the battery.
	The battery has been discharged.	Exchange with a new battery.
	The power fuse is blown.	Replace the fuse.
Displays on the screen are not clearly visible.	Maybe because of too much ambient light, or light is reflecting off of the screen.	Change the location, or the angle of view of the analyzer. Use the CONFIG function to change the Color settings.
Even though there is a signal present it is not displayed.	The input cable or connector is not making good connection.	Check all connections between the source and the analyzer.
The analyzer will not sweep.	Single Sweep mode has been selected.	Change to Continuous Sweep mode.
	Trace is in VIEW mode.	Set the Trace to WRITE mode.
Measurement Levels are incorrect.	Level shift due to environmental changes (temperature etc.).	Redo the internal Calibration procedure.

**SPECTRUM ANALYZER
OPERATION MANUAL**

12. In Occurrence of a Trouble

(cont'd)

Symptom	Possible Cause	Solution
No response to key pushes.	Analyzer is in GPIB Remote Control mode.	End any GPIB control programs that may be running, and return to local control with the LCL key.
SAVE or RECALL does not work.	Memory Card is not inserted (correctly).	Put a memory card conforming to the JEIDA Spec. Ver. 4.1 into one of the two drive slots.
Data is not being stored in the memory card.	Memory card is not initialized.	Initialize the memory card.
	Memory card has WRITE PROTECT ON.	Set the WRITE PROTECT to be OFF.
PRINTER or PLOTTER doesn't work.	Address specification error.	Change the address of the printer or plotter to make it agree with the address set in the hard copy configuration.
	GPIB cable is not connected properly.	Check the GPIB cable routing and connections for bad contact.
Remote control doesn't work. (GPIB operation bad)	GPIB cable is not connected properly.	Check the GPIB cable routing and connections for bad contact.
	Improper GPIB in the control program.	Check over the use of GPIB commands in the program.

13. SPECIFICATIONS

13.1 U3641/U3641PHS

(1) Frequency

Frequency range	9 kHz to 3 GHz
Frequency readout accuracy (Start, Stop, CF, Marker frequency)	\pm (Frequency readout \times freq reference error + 5% \times span + 15% \times RBW + 10 Hz)
Count frequency marker Resolution Count Accuracy	1 Hz to 1 kHz \pm (marker Frequency \times Frequency reference accuracy + 1 LSD \pm 5 Hz) (S/N \geq 25 dB, 1 kHz \leq SPAN \leq 200 MHz, RBW \geq 3 kHz)
Frequency reference Aging Temperature stability	$\pm 2 \times 10^{-6}$ /Year $\pm 1 \times 10^{-5}$ (from 0°C to 50°C)
Frequency span Range Accuracy	1 kHz to 3.2 GHz and 0 Hz (zero span) $\leq \pm 5\%$ of SPAN
Residual FM Zero Span	≤ 60 Hz p-p/100 ms
Frequency Drift Span ≤ 10 kHz	(after warm up 30 min and at constant temperature) < 150 Hz/min
Noise Sidebands	≤ -105 dBc at 20 kHz offset ≤ -100 dBc at 10 kHz offset
Resolution Bandwidth (At 3 dB) Range RBW Accuracy Selectivity	1 kHz to 3 MHz, 1-3 sequence Option 300 Hz, 100 Hz < $\pm 20\%$ from 1 kHz to 1 MHz Option 100 Hz to 1 MHz < $\pm 25\%$ for 3 MHz < 15 : 1 (60 dB : 3 dB) (RBW : 1 kHz to 3 MHz) Option 300 Hz, 100 Hz
Video Bandwidth	10 Hz to 3 MHz (1-3 step)

**SPECTRUM ANALYZER
OPERATION MANUAL**

13.1 U3641/U3641PHS

(2) Amplitude range

Measurement range	+ 20 dBm to displayed Average Noise Level
Maximum input level Preamplifier OFF	(Input attenuator > 10 dB) + 27 dBm ± 50V DC max.
Preamplifier ON	+ 13 dBm ± 50V DC max.
Display range Log	10 × 10 div 10, 5, 2, 1 dB/div
Linear	10% of reference level/div. RBW ≥ 3KHz
Reference level range Preamplifier OFF	(Input attenuator 0 to 50 dB) – 64 dBm to + 40 dBm (0.1 dB step)
Log	141.1 μV to 22.36 V
Linear	
Preamplifier ON	(Input attenuator 0 to 10 dB) – 89 dBm to – 25 dBm (0.1 dB step)
Log	7.934 μV to 12.57 mV
Linear	
Input attenuator range	0 to 50 dB (10 dB step)

**SPECTRUM ANALYZER
OPERATION MANUAL**

13.1 U3641/U3641PHS

(3) Dynamic range

Display Average Noise Level	With RBW 1 kHz, VBW 10 Hz and input attenuator 0 dB, Frequency \geq 1 MHz
Preamplifier OFF	– 117 dBm + 2.7f (GHz) dB
Preamplifier ON	– 135 dBm + 4.3f (GHz) dB
Gain compression (1 dB)	Frequency \geq 10 MHz, input attenuator 0 dB)
Preamplifier OFF	> – 10 dBm (mixer input level)
Preamplifier ON	> – 40 dBm (RF input level)
Spurious response	(Input attenuator 0 dB, frequency \geq 10 MHz)
Preamplifier OFF	
Second harmonic distortion	\leq – 70 dBc for – 30 dBm input
Third order inter modulation distortion	\leq – 70 dBc for – 30 dBm input Frequency difference of two signals > 10 kHz
Residual response	(input terminated 50 Ω , input attenuator 0 dB and Freq > 1 MHz)
Preamplifier OFF	\leq – 100 dBm
Preamplifier ON	\leq – 105 dBm

**SPECTRUM ANALYZER
OPERATION MANUAL**

13.1 U3641/U3641PHS

(4) Amplitude accuracy

Frequency Response	(at input attenuator 10 dB, 20°C to 30°C, referenced to 30 MHz and after calibration)
Preamplifier OFF	≤ ± 1 dB (100 kHz to 2.7 GHz) ≤ ± 2 dB (9 kHz to 3.0 GHz)
Preamplifier ON	≤ ± 1 dB (100 kHz to 2.7 GHz) ≤ ± 2 dB (9 kHz to 3.0 GHz)
Calibration Signal Accuracy	- 20 dBm ± 0.3 dB
IF Gain Uncertainty	(after automatic calibration) < ± 0.5 dB
Scale Fidelity	(after automatic calibration)
Log	≤ ± 1.5 dB/90 dB ≤ ± 1 dB/10 dB ≤ ± 0.2 dB/1 dB
Linear	≤ ± 5% of reference level, RBW ≥ 3kHz
Input attenuator switching accuracy	(20 to 50 dB settings, referenced to 10 dB) ≤ ± 1.0 dB (100 kHz to 2.7 GHz) ≤ ± 1.5 dB (9 kHz to 3.05 GHz)
Resolution bandwidth switching uncertainty	(after automatic calibration) ≤ ± 1.0 dB at RBW referenced to 3MHz

(5) Sweep

Sweep time	50 μs to 1000 s and manual sweep
Accuracy	< ± 5%
Trigger mode	FREE RUN, SINGLE, VIDEO, EXT, TV

(6) Demodulation

Spectrum demodulation	
Modulation type	AM and FM (RBW = or ≥ 3 kHz for FM)
Audio output	Speaker and phone jack with volume control

**SPECTRUM ANALYZER
OPERATION MANUAL**

13.1 U3641/U3641PHS

(7) Input/Output

RF Input Connector Impedance VSWR/Preamplifier OFF VSWR/Preamplifier ON	N-type 50 Ω (nominal) < 1.5 : 1 (100 kHz to 2 GHz) < 2: 1 (9 kHz to 3.0 GHz) with input atten10 dB to 50dB < 2.5 : 1 (10 MHz to 3.0 GHz)
10 MHz Reference input Connector Impedance Input range	BNC female, rear panel 500 Ω (nominal) 0 dBm to + 16 dBm
Video output Connector Impedance Amplitude	BNC female, rear panel 75 Ω (nominal), AC coupled Approx. 1Vp-p, 75 Ω (Composite video signal)
External Trigger input Connector Impedance Trigger level	BNC female, rear panel 10 k Ω (nominal), DC coupled TTL level
Gate input Connector Impedance Sweep stop Sweep continue	BNC female, rear panel 10 k Ω (nominal) during TTL level low level during TTL level high level
Phone Output Connector Power output	Subminiature monophonic jack, front panel 0.2 W 8 Ω (nominal)
GPIB interface Plotter Printer	IEEE-488, bus Connector R9833, HP7470A, HP7475A, HP7440A, HP7550A 682-XA HP2225A
RS-232 Printer	D-SUB 9 pins, rear panel BJ-10, VP-600, MJ400, HP505J

**SPECTRUM ANALYZER
OPERATION MANUAL**

13.1 U3641/U3641PHS

(cont'd)

Power input Battery mounter adapted	Advantest AC/DC adapter Model: A08364 Automatically selections between 100 VAC and 220 VAC Anton Bauer Inc: PROPAC14 battery (nominal 60WH)
TV picture demodulation output Connector Impedance Amplitude	OPTION BNC female, rear panel 75Ω (normal), CD coupled Approx. 1Vp-p, 75Ω termination
TV sound demodulation output Connector Impedance	OPTION Pin female, rear panel 1kΩ (nominal), AC coupled
TV picture signal input Connector Impedance Input level	OPTION BNC female, rear panel 75Ω (normal), AC coupled Approx. 1Vp-p
TV sound signal input Connector Impedance	OPTION Pin female, rear panel 1kΩ (nominal), AC coupled

**SPECTRUM ANALYZER
OPERATION MANUAL**

13.1 U3641/U3641PHS

(8) General specifications

Environment temperature Operating temperature Relative humidity Storage temperature	0°C to +50°C RH 85% or less -20°C to +60°C
Power supply External DC input During AC adapter is used During 100 VAC operation During 220 VAC operation Power consumption	Connector: XLR 4 pin Input range: +10 V to +16 V Automatically selections between 100 VAC and 220 VAC Voltage: 100 V to 120 V Frequency: 50 Hz/60 Hz Voltage: 220 V to 240 V Frequency: 50 Hz/60 Hz During DC operation: 60 W max. During AC adapter is used: 100 VA max.
Mass	6.9 kg or less (Without option, accessory, carrying belt and battery) PROPAC14 battery :2.1kg AC/DC adaptor (A08364) :1.1kg
Dimensions	Approx. 148 mm (height) × 291 mm (wide) × 330 mm (depth) Excluding the projecting (legs, connector, etc.).
External memory Memory card	2 slot, upper panel Connector: JEIDA-Ver4.1, PCMCIA Rel 2.0

**SPECTRUM ANALYZER
OPERATION MANUAL**

13.1 U3641/U3641PHS

(9) PHS-ID Demodulator function (U3641PHS only)

Receiving signal Radio access form Modulation form Transmission speed Signal Channel	TDMA-TDD $\pi/4$ shift QPSK 384Kbit/s The configuration of the logical control channel marks conforms to RCR STD-28.
Range of level measurement Receiving performance Sweep trigger mode	SWP = 400 ms or less in level measurement Preamplifier OFF: (Input ATT = 10 dB) 52dB μ V to 107dB μ V Preamplifier ON: (Input ATT = 0 dB) 16dB μ V to 67dB μ V Free run, VIDEO and ID
Measurement function ID list display ID-MKR Cycle measurement	CI, CS-ID, PS-ID, level and time Displays ID of the specified signal in the waveform display mode. Measures synchronizing signal of the specified CS-ID.
Burst error ratio measurement	Number of error slots/number of measurements (settings)
Level measurement calculation function	Median operation Mean value operation Maximum/Minimum value operation

13.2 U3641N

(1) Frequency

Frequency range	9 kHz to 3 GHz
Frequency readout accuracy (Start, Stop, CF, Marker)	\pm (Frequency readout \times Frequency reference error + 5% \times span + 15% \times RBW + 10 Hz)
Count frequency marker Resolution	1 Hz to 1 kHz
Count Accuracy	\pm (marker frequency \times frequency reference accuracy + 1LSD + 5 Hz) (S/N \geq 25 dB, 1kHz \leq SPAN \leq 200 MHz, RBW \geq 3 kHz)
Frequency reference Aging	$\pm 2 \times 10^{-6}$ /year
Temperature stability	$\pm 1 \times 10^{-5}$ (from 0°C to 50°C)
Frequency span Range	1 kHz to 3.2 GHz and 0 Hz (zero span)
Accuracy	$\leq \pm 5\%$ of Span
Residual FM Zero Span	≤ 60 Hz pp/100 ms
Frequency Drift Span ≤ 10 kHz	(after warm up 30 min and at constant temperature) < 150 Hz /min
Noise Sidebands	≤ -105 dBc at 20 kHz offset ≤ -100 dBc at 10 kHz offset
Resolution Bandwidth At 3 dB: Range	1 kHz to 3 MHz 1-3 sequence Option 300 Hz and 100 Hz
RBW Accuracy	$\leq \pm 20\%$ from 1 kHz to 1 MHz Option from 100 Hz to 1 MHz
Selectivity	$\leq \pm 25\%$ for 3 MHz < 15 : 1 (60 dB : 3 dB) for RBW:1 kHz to 3 MHz Option 300 Hz, 100 Hz
Video Bandwidth	10 Hz to 3 MHz (1-3 step)

**SPECTRUM ANALYZER
OPERATION MANUAL**

13.2 U3641N

(2) Amplitude Range

Measurement range	+ 130 dB μ V to displayed Average Noise Level
Maximum input level Preamplicifier OFF	(Input attenuator > 10 dB) + 134 dB μ V \pm 50 VDC max.
Preamplicifier ON	+ 120 dB μ V \pm 50 VDC max.
Display range Log	10 \times 10 div 10, 5, 2, 1 dB/DIV
Linear	10% of reference level/DIV, RBW \geq 3Hz
Reference level range Preamplicifier OFF	(Input attenuator 0 to 50 dB) + 46 dB μ V to + 150 dB μ V + 198.4 μ V to + 31.44 V
Log	
Linear	
Preamplicifier ON	(Input attenuator 0 to 10 dB) + 21 dB μ V to + 85 dB μ V + 11.16 μ V to + 17.68 mV
Log	
Linear	
Input attenuator range	0 to 50 dB (10 dB step)

**SPECTRUM ANALYZER
OPERATION MANUAL**

13.2 U3641N

(3) Dynamic Range

Display Average Noise Level Preamplifier OFF	(with RBW 1 kHz, VBW 10 Hz and input attenuator 0 dB, Frequency ≥ 1 MHz) $- 8 \text{ dB}\mu\text{V} + 2.7f \text{ (GHz)dB}$
Preamplifier ON	$- 22 \text{ dB}\mu\text{V} + 3.0f \text{ (GHz)dB}$
Gain compression (1 dB) Preamplifier OFF	Frequency ≥ 10 MHz , Input attenuator 0 dB $> + 100 \text{ dB}\mu\text{V}$ (mixer input level)
Preamplifier ON	$> + 80 \text{ dB}\mu\text{V}$ (RF input level)
Spurious response Preamplifier OFF 2nd harmonic distortion	(Input attenuator 0 dB, Frequency ≥ 10 MHz) $\leq - 70 \text{ dBc}$ for $+ 78 \text{ dB}\mu\text{V}$
3rd-order inter modulation distortion	$\leq - 70 \text{ dBc}$ for $+ 78 \text{ dB}\mu\text{V}$ Frequency difference of two signals > 10 kHz
Residual response Preamplifier OFF	(input terminated 75Ω , Input attenuator 0 dB and Frequency > 1 MHz) $\leq + 10 \text{ dB}\mu\text{V}$
Preamplifier ON	$\leq - 5 \text{ dB}\mu\text{V}$

**SPECTRUM ANALYZER
OPERATION MANUAL**

13.2 U3641N

(4) Amplitude Accuracy

Frequency Response	(at input attenuator 10 dB, 20°C to 30°C, referenced to 30 MHz and after calibration)
Preamplifier OFF	≤ ± 1 dB (100 kHz to 2.2 GHz)
Preamplifier ON	≤ ± 1 dB (100 kHz to 2.2 GHz)
Calibration Signal Accuracy	+ 90.5 dB μ V ± 0.3 dB
IF Gain Uncertainty	(after automatic calibration) < ± 0.5 dB
Scale Fidelity	(after automatic calibration)
Log	≤ ± 1.5 dB/90 dB ≤ ± 1 dB/10 dB ≤ ± 0.2 dB/1 dB
Linear	± 5% of reference level, RBW ≥ 3Hz
Input attenuator switching accuracy	(20 to 50 dB settings, referenced to 10 dB) ≤ ± 1.0 dB (100 kHz to 2 GHz)
Resolution bandwidth switching uncertainty	(after automatic calibration) ≤ ± 1.0 dB at RBW referenced to 3MHz)

(5) Sweep

Sweep time	50 μ s to 1000 s and manual sweep
Accuracy	< ± 5%
Trigger mode	FREE RUN, SINGLE, VIDEO, EXT, TV

(6) Demodulation

Spectrum demodulation	
Modulation type	AM and FM (RBW = or ≥ 3 kHz for FM)
Audio output	Speaker and phone jack with volume control

**SPECTRUM ANALYZER
OPERATION MANUAL**

13.2 U3641N

(7) Input & Output

RF Input	
Connector	N-type female
Impedance	75 Ω (nominal)
VSWR/Preamplifier OFF	< 1.5:1 (100 kHz to 2 GHz) < 2:1 (9 kHz to 2.2 GHz) with input atten 10 dB to 50 dB
VSWR/Preamplifier ON	< 2.5:1 (10 MHz to 2.2 GHz)
10 MHz Reference input	
Connector	BNC female, rear panel
Impedance	500 Ω (nominal)
Input Range	0 dBm to + 16 dBm
Video output	
Connector	BNC female, rear panel
Impedance	75 Ω (nominal) AC coupled
Amplitude	Approx. 1Vp-p, 75 Ω (Composite video, signal)
External Trigger input	
Connector	BNC female, rear panel
Impedance	10 k Ω (nominal), DC coupled
Trigger level	TTL level
Gate input	
Connector	BNC female, rear panel
Impedance	10 k Ω (nominal)
Sweep stop	during TTL low level
Sweep continue	during TTL high level
Phone Output	
Connector	Subminiature monophonic jack, front panel
Power Output	0.2 W, 8 Ω (nominal)
GPIB interface	
Plotter	IEEE-488, bus Connector R9833, HP7470A, HP7475A, HP7440A, HP7550A 682-XA
Printer	HP2225A
RS-232	
Printer	D-SUB 9 pin, rear panel BJ-10, VP-600, MJ400, HP505J

**SPECTRUM ANALYZER
OPERATION MANUAL**

13.2 U3641N

(cont'd)

Power input Battery mounter adapted	Advantest AC/DC adapter Model: A08364 Automatically selections between 100 VAC and 220 VAC Antonbauer Inc: PROPAC14 battery (nominal 60WH)
TV picture demodulation output Connector Impedance Amplitude	OPTION BNC female, rear panel 75 Ω (nominal), DC coupled Approx. 1Vp-p, 75 Ω termination
TV sound demodulation output Connector Impedance	OPTION Pin female, rear panel 1k Ω (nominal), AC coupled
TV picture signal input Connector Impedance Input level	OPTION BNC female, rear panel 75 Ω (nominal), AC coupled Approx. 1Vp-p
TV sound signal input Connector Impedance	OPTION Pin female, rear panel 1k Ω (nominal), AC coupled

**SPECTRUM ANALYZER
OPERATION MANUAL**

13.2 U3641N

(8) General specifications

Environment temperature Operating temperature Relative humidity Storage temperature	0°C to +50°C RH 85% or less -20°C to +60°C
Power supply External DC input During AC adapter is used During 100 VAC operation During 220 VAC operation Power consumption	Connector: XLR 4 pin Input range: +10V to +16V Automatically selections between 100 VAC and 220 VAC Voltage: 100 V to 120 V Frequency: 50Hz/60Hz Voltage: 220 V to 240 V Frequency: 50Hz/60Hz During DC operation: 60W max. During AC adapter is used: 100VA max.
Mass	6.9 kg or less (Without option, accessory, carrying belt and battery) PROPACbattery : 2.1kg AC/DC adaptor (A08364) : 1.1kg
Dimensions	Approx. 148 mm (height) × 291 mm (wide) × 330 mm (depth) Excluding the projecting (legs, connector, etc.).
External memory Memory card	2 slot, upper panel Connector: JEIDA-Ver4.1, PCMCIA Rel 2.0

13.3 U3641/U3641PHS/U3641N Option

(1) OPT20 High-stable Reference Oscillator

Frequency	10MHz
Frequency stability	$\pm 2 \times 10^{-8}/\text{day}$ $\pm 1 \times 10^{-7}/\text{year}$

U3641PHS : Can not be installed at same time.

(2) OPT26 Narrow RBW

Resolution bandwidth (3 dB)	
Range	300 Hz, 100 Hz
Bandwidth accuracy	$\leq \pm 20\%$
Selectivity	$\leq 15 : 1$ (60 dB : 3 dB)

(3) OPT 72 TV Picture Monitor

TV demodulation demoed type TV STD demoed output	NTSC, PAL, SECAM M, B/G. D/K/K', I, L/K' Video, Sound
TV Video demod output Connector Impedance Amplitude	BNC Jack (rear panel) 75 Ω (nominal), DC coupled Approx, 1 Vp-p 75 Ω termination
TV Sound demod output Connector Impedance	Pin Jack (rear panel) 1k Ω (nominal), AC coupled
TV Video signal input Connector Impedance Input level	BNC Jack (rear panel) 75 Ω (nominal), DC coupled Approx, 1 Vp-p
TV Sound signal output Connector Impedance	Pin Jack (rear panel) 1k Ω (nominal), AC coupled

U3641PHS : Can not be installed at same time.

**SPECTRUM ANALYZER
OPERATION MANUAL**

13.3 U3641/U3641PHS/U3641N Option

(4) OPT 74 Tracking Generator

Frequency range	100kHz to 2.2GHz
Output range	0dBm to -31dBm 1dB step (U3641N 105dB μ to 74dB μ)
Level accuracy	$\leq \pm 0.5$ dB (30MHz - 10dBm, 20°C to 30°C) (U3641N at 90dB μ)
Level flatness	(at -10 dBm with reference to 30 MHz) (at 95 dB μ with reference to 30 MHz for U3641N) $\leq \pm 0.7$ dB (100kHz to 1GHz) $\leq \pm 1.5$ dB (100kHz to 2.2GHz)
Output level switching accuracy	(with reference to -10 dBm) (with reference to 95 dB μ for U3641N) $\leq \pm 1.0$ dB (100kHz to 1GHz) $\leq \pm 2.0$ dB (100kHz to 2.2GHz)
Output level Spurious	Harmonics < -20dBc Non harmonics < -30dBc
TG leakage	≤ -95 dBm (16dB μ or less for U3641N)
TG output Connector Impedance	N type jack 50 Ω (nominal) VSWR ≤ 1.5 (100kHz to 2GHz) VSWR ≤ 2.0 (100kHz to 2.2GHz) (Output level is -10 dBm or less) U3641N: Impedance 75 Ω (nominal) VSWR ≤ 1.5 (100kHz to 2GHz) VSWR ≤ 2.0 (100kHz to 2.2GHz) (Output level is 95 dB μ or less)

(5) OPT 78 Channel Setting

Channel setting	Setting of VHF, UHF, CATV, BS and CS channels of each country Up to 99 channels can be set to each of two user channel systems.
-----------------	--

OPT78 : Involeved in OPT-72

APPENDIX

A.1 Glossary

IF Bandwidth

The spectrum analyzer uses band pass filter (BPF) to analyze the frequency components contained in the input signal. The 3dB bandwidth of the BPF is called the IF band (See Figure A-1(a)).

The BPF characteristics should be set according to the sweep width and the sweep speed used for the waveform. This spectrum analyzer sets the optimal value according to the sweep width. In general, smaller bandwidths improve resolution. Therefore, the resolution of the spectrum analyzer can be expressed by the narrowest IF bandwidth (See Figure A-1 (b)).

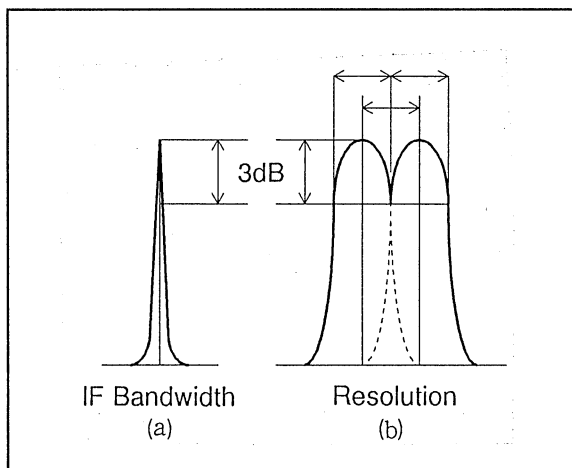

Figure A-1 IF Bandwidth

Electromagnetic compatibility (EMC)

The ability of a system to operate without producing or being affected by electromagnetic interference.

Electromagnetic interference (EMI)

Electromagnetic interference (EMI) is a disturbance in the reception of desired signals caused by unwanted electromagnetic energy, or something. EMI can be caused by any source of EM energy, such as (list a pertinent rew). Modern circuits are designed to produce as little EM energy as possible, but since the EM can not be completely eliminated. the cabinets containing EM-can not equipment are shielded to exclude EMI.

Reference Level Display Accuracy

When reading the absolute level of an input signal on the spectrum analyzer, the level is determined by the distance in dB from the uppermost scale on the screen. The level set for this uppermost scale is called reference level.

The reference level is modified by the IF GAIN key and the input attenuator, and displayed in dBm or dB μ . The absolute accuracy of this display is the reference level accuracy.

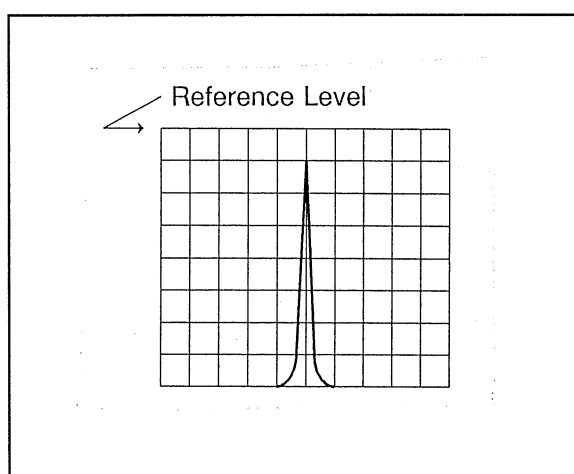

Figure A-2 Reference Level

Gain Compression

If the input signal is greater than a certain value, the correct value is not displayed on the CRT and the input signal appears as if it were compressed. This phenomenon is called gain compression, and it expresses the linearity of the input signal range. Max gain compression is 1dB.

Maximum Input Sensitivity

This is the maximum sensitivity of the spectrum analyzer to detect signals. The sensitivity is affected by the noise generated by the spectrum analyzer itself and depends on the IF bandwidth. The maximum input sensitivity is normally expressed as the average noise level in the minimum IF bandwidth of the spectrum analyzer.

Maximum Input Level

This is the maximum level allowed for the input circuit of the spectrum analyzer. The level can be modified by the input attenuator.

Residual FM

The short-period frequency stability of the local oscillators built in the spectrum analyzer is expressed as residual FM. The frequency width fluctuating per unit time is expressed by p-p. This also determines the measurement limit value when measuring the residual FM of the signal.

Residual Response

Residual response is a measure of how much (in the input level calculation) the spurious signal generated in the spectrum analyzer is suppressed. Residual response is generated by leaks of particular signals such as local oscillation output in the spectrum analyzer. This should be taken into consideration when analyzing a precise input signal.

Quasi-Peak Value Measurements

In radio communication, EMI usually appears as an impulse. To evaluate this interference, the analyzer uses the noise power in proportion to the peak value. The measurement bandwidth and detection constant used for this evaluation are called quasi-peak value measurements, and are determined by JRTC specifications (in Japan) and CISPR specifications (international).

Frequency Response

This term represents amplitude characteristics (frequency characteristics) for a given frequency. In the spectrum analyzer, frequency response means the frequency characteristics (flatness) of input attenuator and mixer for the input frequency, and is given in $\pm \Delta$ dB.

Zero Span

The spectrum analyzer sweeps at any frequency along the horizontal axis as the time axis but will not sweep in zero span mode.

Occupied Bandwidth

Modulation causes the frequency spectrum of an EM signal to spread significantly. The occupied bandwidth is the portion of the signals that contains 99% of the total average power radiated (See Figure A-3).

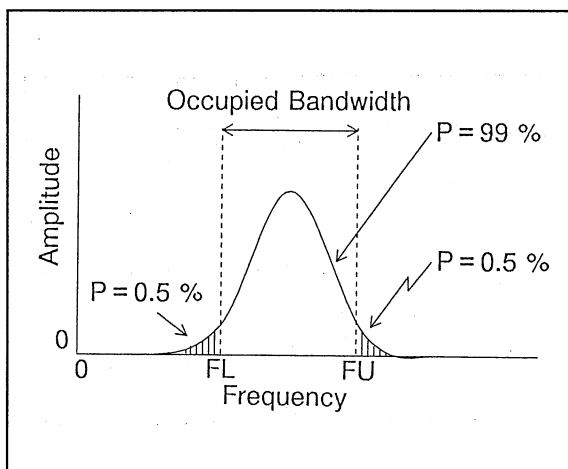

Figure A-3 Occupied Bandwidth

Spurious Signals

Spurious signals are undesired signals that can interfere with the target signal. Spurious signals can be divided into several types as follows:

- Higher Harmonic spurious : This is the higher harmonic level generated by the spectrum analyzer itself (normally in the mixer circuit) when an ideal undistorted signal is fed to the analyzer. This also means the efficiency to measure higher harmonic distortion.
- Adjacent spurious : This is the small spurious signal generated in the vicinity of the spectrum when a pure, single-spectrum signal is fed to the spectrum analyzer.
- Non-higher Harmonic spurious : This is a spurious signal of a certain inherent frequency generated by the spectrum analyzer itself. This is also called residual response.

Spurious Response

This is distortion caused by the higher harmonic spurious signal generated in the input mixer when the signal level is increased. The range that can be used without distortion varies according to the input level of the basic wave. In the example shown Figure A-4 , the range is from -30dBm to -70dB. If the input signal level is too great, the input attenuator is used to decrease the signal fed to the mixer so that a proper input level can be obtained.

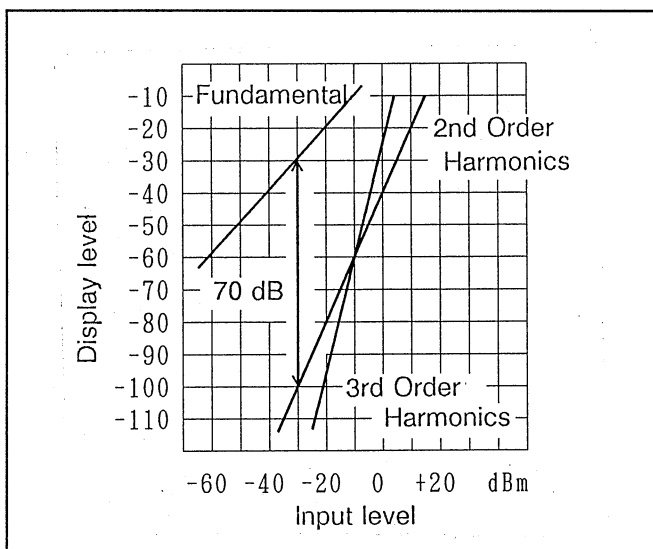

Figure A-4 Spurious Response

Noise Sideband

The spectrum analyzer efficiency is lowered by the noise generated in the local oscillator and phase lock loop of the analyzer itself, which will appear in the vicinity of the spectrum on the display. To compensate for this, the sideband of the analyzer itself is defined so that signals out of the sideband can be analyzed in a certain range. This range is called the noise sideband.

The spectrum analyzer's noise sideband characteristics are expressed in the following example.

Example: Suppose the IF bandwidth is 1kHz, -70dB at 20kHz apart from the carrier. The noise level is normally expressed by the energy contained in the 1Hz bandwidth. (See Figure A-5 (b).)

If this is expressed in 1Hz bandwidth: Since the value is -70dB when the bandwidth is 1kHz, the signals within the 1Hz bandwidth will be lower than this by about $10 \log 1\text{Hz}/1\text{kHz}$ [dB] , or about 30dB; consequently, it is expressed as -100dB/Hz at 20kHz apart from the carrier when the IF bandwidth is 1kHz.

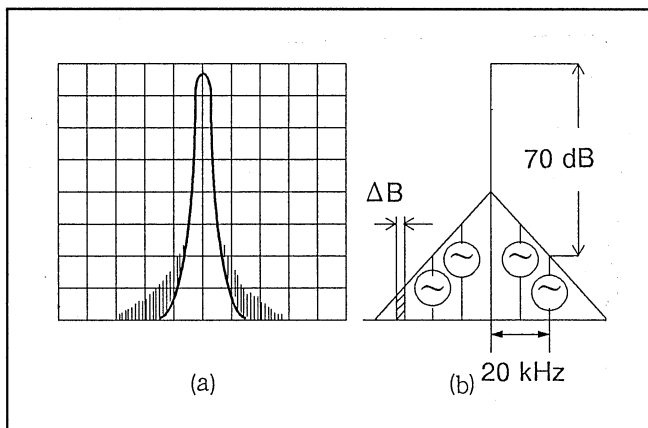

Figure A-5 Noise Sideband

Resolution Bandwidth Selectivity

The band pass filter normally attenuates Gauss distribution instead of so-called rectangular characteristics. Consequently, if two adjacent signals of different sizes are mixed, the smaller signal "hides" at the tail of the larger signal (See Figure A-6). Therefore, the bandwidth at a certain attenuation range (60dB) should also be defined. The ratio between the 3dB width and 60dB width is expressed as the bandwidth selectivity.

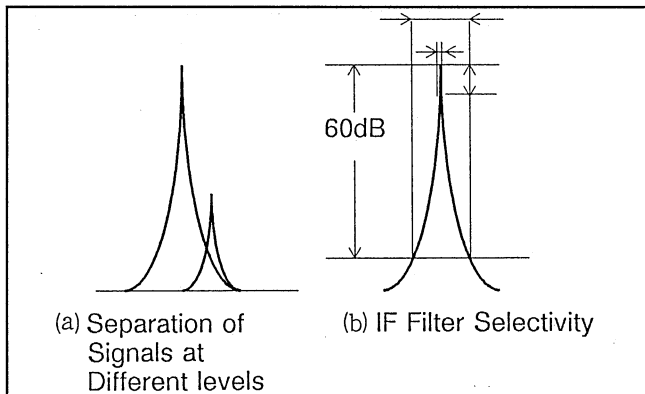

Figure A-6 Bandwidth Selectivity

Bandwidth Accuracy

The bandwidth accuracy of the IF filter is expressed by the deviation from the nominal value of the 3dB-lowered point. This efficiency has almost no effect on measurement of normal signals of continuous level, but it should be taken into consideration when measuring the level of a noise signal.

Bandwidth Switching Accuracy

Several IF filters are used to obtain optimal resolution (in signal spectrum analysis) according to the scan width. When switching from one IF filter to another while measuring one and the same signal, an error is generated for the difference in loss. This error defined as the bandwidth switching accuracy.

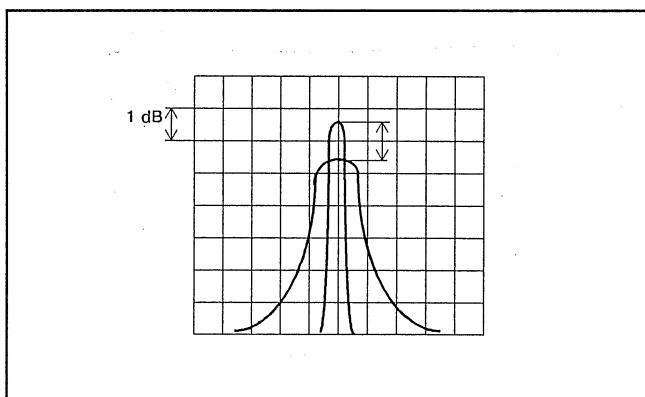

Figure A-7 Bandwidth Switching Accuracy

Voltage Standing Wave Ratio (VSWR)

This is a constant that represents the impedance matching state. It is expressed as the ratio between the maximum and minimum values in the standing wave generated as a combination of progressive wave and reflected wave in the spectrum analyzer loaded against the ideal nominal impedance source. This is a variation of reflection factor and reflection attenuation amount.

In Figure A-8, the value of signal E_1 received at the receiver (spectrum analyzer input) is identical to that of E_0 if E_0 is transmitted to the receiver without impedance mismatching. If the signal is completely reflected due to mismatching of the receiver and returned to the transmitter, the ratio of reflection, i. e., the reflection factor can be expressed as follows, assuming E_R as the reflected wave size:

Reflection factor $m = \text{Reflected wave } E_R / \text{Progressive wave } E_0$

Return loss (dB) = $20 \log E_R / E_0$ [dB]

$VSWR = (E_0 + E_R) / (E_0 - E_R)$

The relationship to the reflection factor will be:

$VSWR = (1 + |m|) / (1 - |m|)$

The VSWR will be in the range 1 to ∞ . The matching state is improved as the value approaches 1.

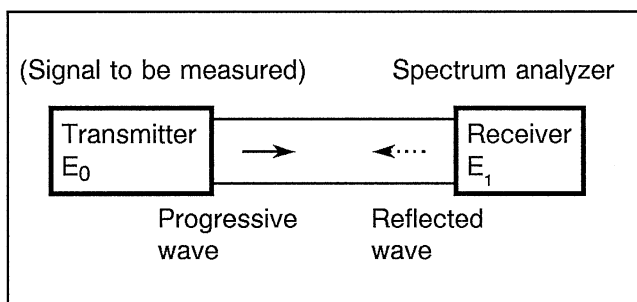

Figure A-8 VSWR

YIG-tuned Oscillator

This was first reported by Griffiths in 1946. Garnet ferrites such as YIG (Yttrium-iron garnet) monocrystal show extremely sharp electron spin resonance in the microwave area, and has a resonance frequency in proportion to the direct-current magnetic field applied over a wide frequency range. Therefore, YIG crystals can be used for wide-range electronic tuning, changing the current exciting the elector magnet that generates direct current magnetic field. YIG crystals are used in the local sweep generator of the spectrum analyzer and in other devices such as auto microwave frequency counters.

A.2 dB Conversion Formulas

dB Conversion Formulas

Definitions

0dBV = 1Vrms	$Y_{dBV} = 20\log \frac{XV}{1V}$
0dBm = 1mW	$Y_{dBm} = 10\log \frac{XmW}{1mW}$
0dBμV = 1μVrms	$Y_{dB\mu V} = 20\log \frac{X\mu V}{1\mu V}$
0dBpw = 1pW	$Y_{dBpw} = 10\log \frac{XpW}{1pW}$

Conversion formulas

If R = 50 Ω: dBV ≅ (dBm - 13dB) dBμV ≅ (dBm + 107dB) dBμVemf ≅ (dBm + 113dB) dBpw ≅ (dBm + 90dB)	If R = 75 Ω: dBV ≅ (dBm - 11dB) dBμV ≅ (dBm + 109dB) dBμVemf ≅ (dBm + 115dB) dBpw ≅ (dBm + 90dB)
--	--

Examples

Converting 1mV into dBμV:	$20\log \frac{1mV}{1\mu V} = 20\log 10^3 = 60dB\mu V$
Converting 0dBm into dBμV:	$\begin{cases} 0dBm + 107dB = 107dB\mu V (R = 50\Omega) \\ 0dBm + 109dB = 109dB\mu V (R = 75\Omega) \end{cases}$
Converting 60dBμV into dBm:	$\begin{cases} 60dB\mu V - 107dB = -47dBm (R = 50\Omega) \\ 60dB\mu V - 109dB = -49dBm (R = 75\Omega) \end{cases}$
Converting 10V/m into dBμV/m:	$20\log \frac{10V/m}{1\mu V/m} = 140dB\mu V/m$

Relationship between dBm and Watt

+50dBm	+40dBm	+30dBm	+20dBm	+10dBm	+0dBm	-10dBm	-20dBm	-30dBm
100W	10W	1W	100mW	10mW	1mW	0.1mW	0.01mW	0.001mW

A.3 Menu Lists

A.3.1 Softkey Menu

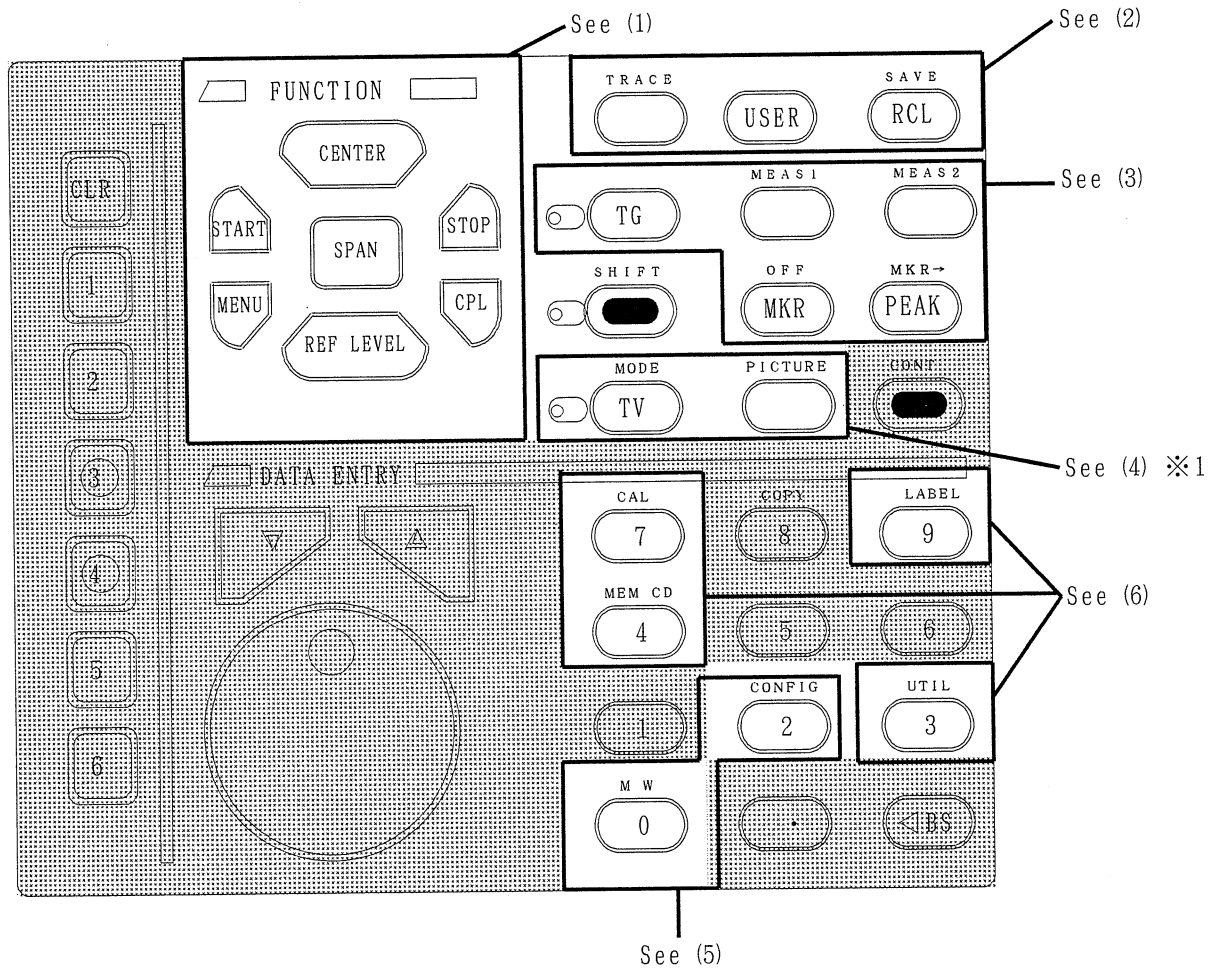

※1 : About U3641PHS, TV key becomes PHS key and PICTURE key become AUTO key.
About the soft key menu of PHS key and AUTO key, please refer to PART 2.

(1)

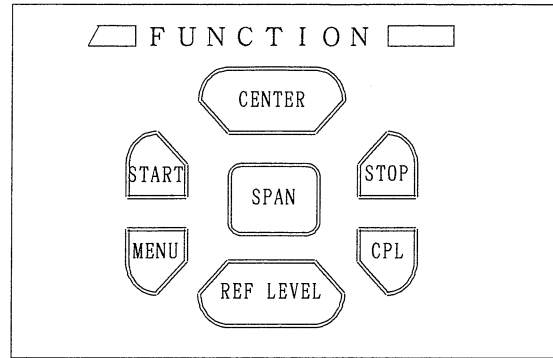

MENU
(Refer to item 7.1.6)

- 1 TRIGGER
- 2 TRACE DET
- 3 SWEEP MODE
- 4 SOUND
- 5 DSP LINE ON/OFF
- 6 NEXT

- 1 FREE RUN
- 2 TV
- 3 TRIGGER POSITION
- 4 VIDEO
- 5 EXT
- 6 SLOPE +/-

- 1 TV-V
- 2 TV-H
- 3 NTSC
- 4 PAL & SECAM
- 5 POLARITY +/-
- 6 RETURN

- 1 NORMAL
- 2 POSI
- 3 NEGA
- 4 SAMPLE

- 1 CONT SWEEP
- 2 SINGLE SWEEP
- 3 SWEEP RESET
- 4 MANUAL SWEEP
- 5 WINDOW SWEEP
- 6 MK PAUSE ON/OFF

- 1 AM/FM
- 2 DEMOD TIME
- 6 SOUND OFF

- 1 COLORS
- 2 COLOR DEFINE

- 1 COLOR TYPE 1
- 2 COLOR TYPE 2
- 3 COLOR TYPE 3
- 4 COLOR TYPE 4
- 5 COLOR USER
- 6 RETURN

- 1 PARAMTR UP
- 2 PARAMTR DOWN
- 3 ACTIVE RGB
- 4 SAVE
- 6 RETURN

- 1 CONFIRM
- 6 CANCEL

CENTER
(Refer to item 7.1.1)

- 1 CF STEP AUTO/MNL
- 2 FREQ OFS ON/OFF

SPAN
(Refer to item 7.1.2)

- 1 FULL SPAN
- 2 ZERO SPAN
- 3 LAST SPAN

REF LEVEL
(Refer to item 7.1.3)

- 1 dB/div
- 2 LINEAR
- 3 UNITS
- 4 REF OFS ON/OFF

- 1 dBm
- 2 dBpW
- 3 WATTS
- 6 VOLT UNITS
- 1 dBmV
- 2 dBμV
- 3 dBμVemf
- 4 VOLTS
- 6 POWER UNITS

START
(Refer to item 7.1.3)

- 1 FREQ OFS ON/OFF

STOP
(Refer to item 7.1.3)

- 1 FREQ OFS ON/OFF

CPL
(Refer to item 7.1.5)

- 1 RBW AUTO/MNL
- 2 VBW AUTO/MNL
- 3 SWP AUTO/MNL
- 4 ATT AUTO/MNL
- 5 WIDE RBW ON/OFF
- 6 ALL AUTO

(2)

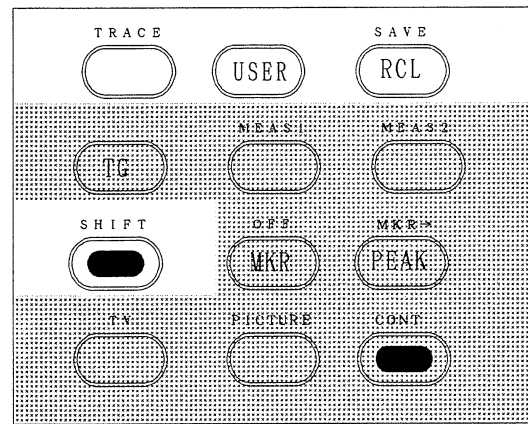

(Refer to section 7.2)

- 1 WRITE
 - 2 VIEW /BLANK
 - 3 MAX HOLD
 - 4 MIN HOLD
 - 5 AVERAGE
 - 6 NEXT
- 1 START / STOP
 - 2 PAUSE / CONT
 - 3 AVG TIME 1/CONT
 - 5 TRC DET SMPL/POS
 - 6 RETURN
- 1 TRACE B
 - 3 TRACE MATH
 - 6 RETURN
- 1 STORE B
 - 2 VIEW B
 - 3 BLANK B
 - 4 WRITE B
 - 6 RETURN
- 1 A XCH B
 - 2 A-B→A
 - 3 B-A→B
 - 4 A-DL→A
 - 5 NORMLIZE
 - 6 RETURN
- 1 NORMLIZE ON/OFF
 - 2 SAVE CORR DAT
 - 3 INSTANT NORMLIZE
 - 5 CORR DAT BKUP/MEM
 - 6 RETURN



(Refer to section 7.5)

- 1 USER 1
- 2 USER 2
- 3 USER 3
- 4 USER 4
- 5 USER 5
- 6 USER 6

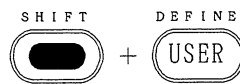

(Refer to section 7.5)

- 1 GROUP ACTIVE
 - 2 MEMBER ACTIVE
 - 3 ENTER
 - 4 DELETE
 - 5 INITIAL MODE
 - 6 RETURN
- 1 INITIAL GROUP
 - 2 INITIAL ALL
 - 6 RETURN



(Refer to section 7.6)

- (at NORMAL mode)
 - 1 RECALL EXECUTE
 - 2 SHOW FILE
 - 3 RECALL DEFINE
 - 5 CARD DRV A / B
 - 6 FAST/ NORMAL
- 5 PROTECT ON/OFF
 - 6 RETURN
- (at FAST mode)
 - 3 RECALL DEFINE
 - 5 CARD DRV A/B
 - 6 FAST/ NORMAL

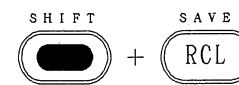

(Refer to section 7.6)

- 1 SAVE EXECUTE
 - 2 SHOW FILE
 - 3 SAVE ITEM
 - 4 DELETE FILE
 - 5 CARD DRVA / B
 - 6 RENAME
- 1 CONFIRM
 - 6 CANCEL
- 5 PROTECT ON/OFF
 - 6 RETURN
- 1 SELECT →
 - 4 DEFAULT
 - 6 RETURN
- 1 CONFIRM
 - 6 CANCEL
- 1 MARK 1/ 2/ 3
 - 2 SPACE
 - 3 LABEL CLEAR
 - 6 RETURN

(3)

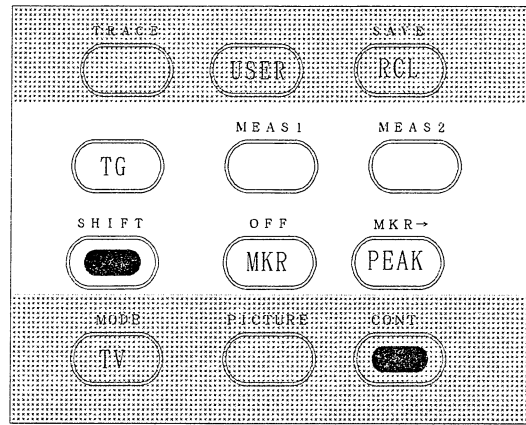

- 1 CNT RES 1 kHz
- 2 CNT RES 100 Hz
- 3 CNT RES 10 Hz
- 4 CNT RES 1 Hz
- 6 COUNTER OFF

MEAS 1
(Refer to section 7.4)

- 1 HI-SENS ON/OFF
 - 2 COUNTER
 - 3 DELAY SWEEP
 - 4 GATED SWEEP
 - 5 PEAK LIST
- 1 TRIGGER
 - 2 DELAY POSITION
 - 3 DLY SWP TIME
 - 4 DLY SWP ON/OFF
 - 5 SWEEP TIME
 - 6 DELAY OFF
- 1 GATE SIG EXT/INT
 - 2 GATE POSITION
 - 3 GATE WIDTH
 - 4 T-DOMAIN SWEEP
 - 5 GTD SWP ON/OFF
 - 6 GATED OFF
- 1 SINGLE SWEEP
 - 3 LST SORT FREQ/LVL
 - 4 PEAK ΔY div
 - 5 ALL/UP/LOW
 - 6 PEAK LST OFF

- 1 VIDEO
 - 2 EXT
 - 3 SLOPE +/-
 - 5 TV
 - 6 RETURN
- 1 TV-V
 - 2 TV-H
 - 3 NTSC
 - 4 PAL & SECAM
 - 5 POLARITY +/-
 - 6 RETURN

MEAS 2
(Refer to section 7.4)

- 1 dB DOWN
 - 2 3rd ORD MEAS
 - 3 % AM
 - 4 OBW
 - 5 ACP
 - 6 Power Meas
- 1 X dB DOWN
 - 2 X dB LEFT
 - 3 X dB RIGHT
 - 4 REL/ABSL /ABSR
 - 5 CONT ON/OFF
- 1 ACP CH SP/BS
 - 2 ACP POINT
 - 3 GRAPH ON/OFF
 - 4 MKR->CF
 - 5 MARKER MOVE
- 1 Channel Power
 - 2 Total Power
 - 3 AVERAGE POWER
 - 4 CARRIER POWER
 - 5 DSP POSI UP/LOW
 - 6 RETURN

- TG
- 1 TG LEVEL
 - 3 TG ADJ AUTO
 - 4 TG ADJ MANUAL
 - 6 TG OFF
- (Refer to section 10.5)

- OFF MKR
- 1 NORMAL MARKER
 - 2 Δ MKR
 - 3 MULTI MARKER
 - 4 SIG TRK ON/OFF
 - 5 NOIZE/ XHz
 - 6 NEXT
- 1 FIXED MK ON/OFF
 - 2 1/ Δ MKR ON/OFF
 - 3 %
- 1 MLT MKR SET
 - 2 MKR LIST ON/OFF
 - 3 PK LIST LEVEL
 - 4 PK LIST FREQ
 - 5 MLT MKR RESET
 - 6 MLT MKR OFF
- 1 MKR NO X
 - 2 MKR ON
 - 3 MKR OFF
 - 4 ACTIVE MKR
 - 6 RETURN
- 1 dBm/Hz
 - 2 dB μV/√Hz
 - 3 dBc/Hz
 - 6 NOISE/Hz OFF
- 1 LEVEL REL/ABS
 - 2 A ↔ B
 - 6 RETURN

- PEAK
- 1 MKR->CF
 - 2 MKR->REF
 - 3 NEXT PEAK
 - 4 NEXT PK RIGHT
 - 5 NEXT PK LEFT
 - 6 NEXT
- 1 MINIMUM PEAK
 - 2 NEXT MINIMUM
 - 3 CONT PK ON/OFF
 - 4 PEAK ΔY div
 - 5 ALL/UP /LOW
 - 6 RETURN

- SHIFT + MKR-> PEAK
- 1 MKR->CF
 - 2 MKR->REF
 - 3 MKRΔ-> SPAN
 - 4 MKR-> CF STEP
 - 5 MKRΔ-> CF STEP
 - 6 NEXT
- 1 MKRΔ-> CF
 - 2 MKR-> MKR STEP
 - 3 MKRΔ-> MKR STEP
 - 4 MKR STEP AUTO/MNL

(4)

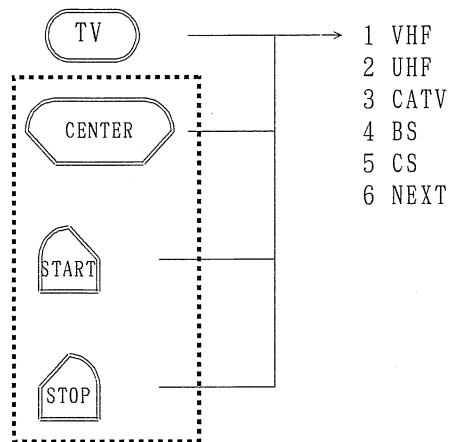
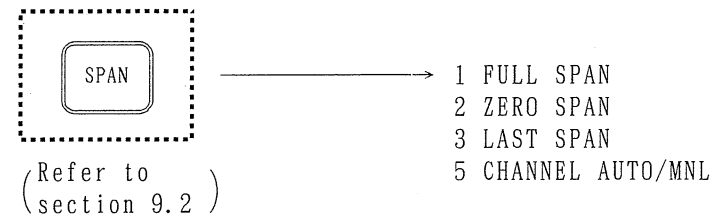
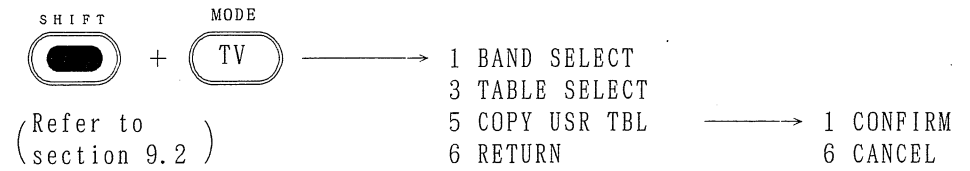
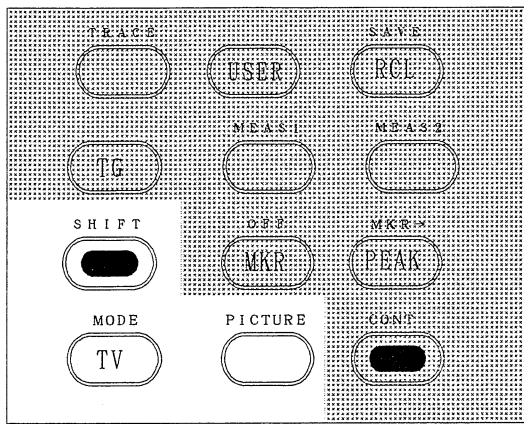

(Refer to section 9.1)

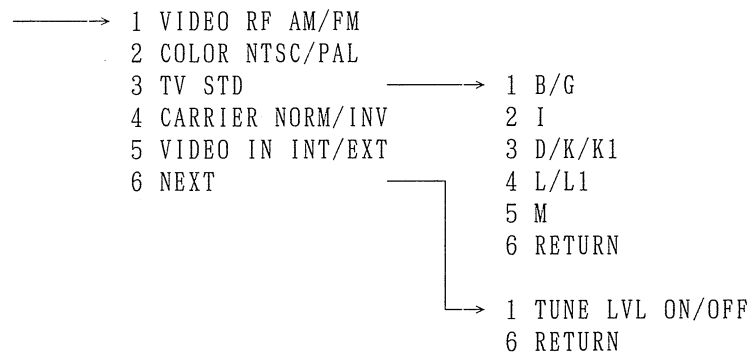
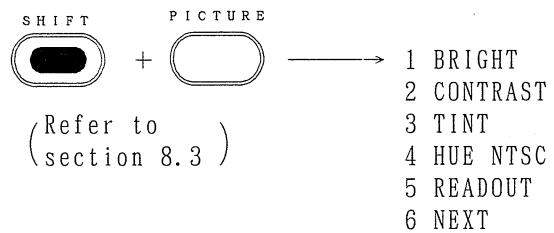
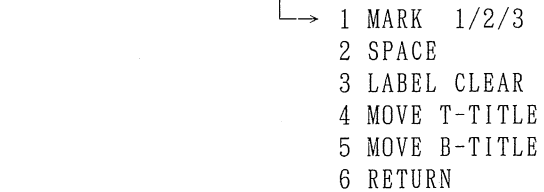
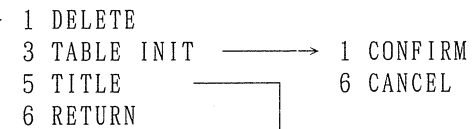
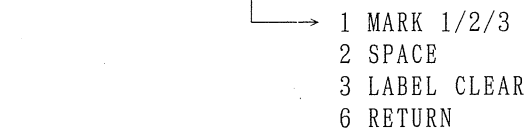
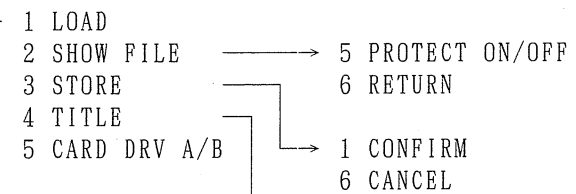
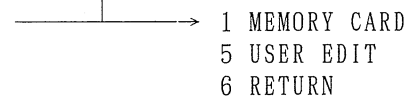
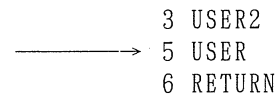

Key operation at TV channel input mode

(5)

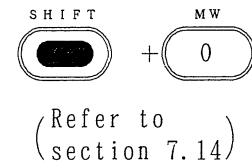
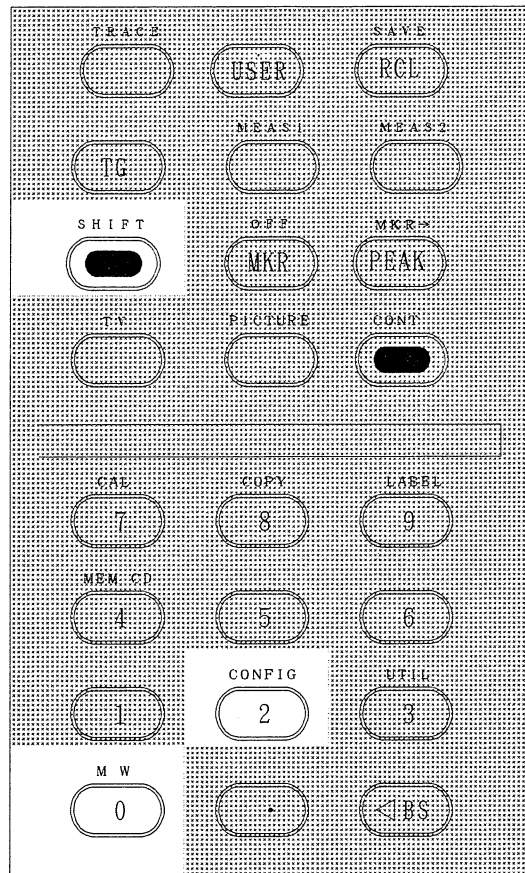

- 1 LOCATE X
- 2 DELTA X
- 3 START/ STOP
- 4 SWEEP NORM/WDO
- 5 WINDOW OFF
- 6 NEXT

- 1 LOCATE Y
- 2 DELTA Y
- 3 UPPER/ LOWER
- 6 RETURN

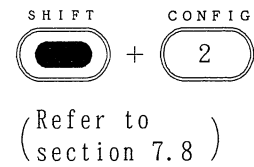

- 1 COPY DEV
- 2 PRINTER CONFIG
- 3 PLOTTER CONFIG
- 4 FILE CONFIG
- 5 COPY CANCEL
- 6 NEXT

- 1 PRINTER
- 2 PLOTTER
- 3 A
- 4 B
- 6 RETURN

- 1 PRNT SIZ LRG/SML
- 2 TALK/ ADRS 01
- 3 PRT CMND PCL/ESC
- 6 RETURN

- 1 PLOTTER TYPE
- 2 PLOT MODE
- 3 TABLE
- 4 PLOT FORM
- 5 LOCATE AUTO/MNL
- 6 TALK / ADRS 01

- 1 PAPER SIZE
- 2 PEN
- 3 PLOT DIVISION
- 4 LOCATION
- 6 RETURN

- 1 FILENAME ADVN0001
- 2 AUTO INC ON/OFF
- 4 BITMAP NORM/INV
- 6 RETURN

- (When OPT-20 is not installed)
- 1 SETUP RS232
- 2 CPU CHK ON/OFF
- 4 DC CHECK ON/OFF
- 5 10M REF EXT/INT
- 6 NEXT

- 1 BAUD
- 2 DATA LENGTH
- 3 STOP BIT
- 4 PARITY
- 5 FLOW CONTROL
- 6 NEXT

- (When OPT-20 is installed)
- 1 SETUP RS232
- 2 CPU CHK ON/OFF
- 4 DC CHECK ON/OFF
- 5 10M REF EXT/OPT
- 6 NEXT

- 1 DATE
- 2 POWER
- 6 RETURN

- (When OPT-15 is not installed)
- 1
- 2 INTERVAL
- 3 OPEN
- 4 CLOSE
- 5 PROTOCOL RMT/CPY
- 6 RETURN

- (When OPT-15 is installed)
- 1 DEV SW MAIN/CTL
- 2 INTERVAL
- 3 OPEN
- 4 CLOSE
- 5 PROTOCOL RMT/CPY
- 6 RETURN

- 1 YEAR
- 2 MONTH
- 3 DAY
- 4 HOUR
- 5 MIN
- 6 DATE ON/OFF

- 1 I/O PORT ON/OFF
- 6 RETURN

(6)

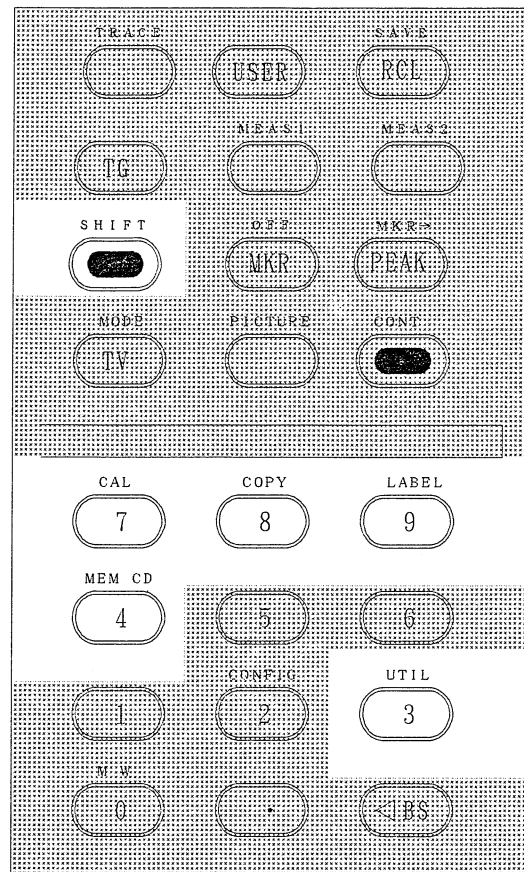

SHIFT + UTIL 3
 (Refer to section 7.12)

- 1 ANTENNA SELECT
- 2 CORR TABLE
- 3 PASS / FAIL
- 4 F-DOMAIN LMT LINE
- 5 T-DOMAIN LMT LINE

- 1 DIPOLE
- 2 LOG PERD
- 6 CORR OFF

- 1 CORR EDIT
- 2 CORR ON/OFF
- 3 CORR MD ANT/LVL
- 6 RETURN

- 1 INSERT ON/OFF
- 2 CURSOR CHANGE
- 3 LINE DELETE
- 4 TABLE INIT
- 6 RETURN

- 1 CONFIRM
- 6 CANCEL

- 1 CONT P/F ON/OFF
- 3 EXECUTE
- 6 RETURN

- 1 LIMIT LINE 1
- 2 LIMIT LINE 2
- 3 FREQ ABS/REL
- 4 LEVEL ABS/REL
- 5 LIMIT 1 ON/OFF
- 6 LIMIT 2 ON/OFF

- 1 INSERT ON/OFF
- 2 CURSOR CHANGE
- 3 LINE DELETE
- 4 TABLE INIT
- 5 TABLE COPY
- 6 RETURN

- 1 CONFIRM
- 6 CANCEL

- 1 LIMIT LINE 1
- 2 LIMIT LINE 2
- 3 TIME ABS/REL
- 4 LEVEL ABS/REL
- 5 LIMIT 1 ON/OFF
- 6 LIMIT 2 ON/OFF

- 1 INSERT ON/OFF
- 2 CURSOR CHANGE
- 3 LINE DELETE
- 4 TABLE INIT
- 5 TABLE COPY
- 6 RETURN

- 1 CONFIRM
- 6 CANCEL

SHIFT + MEM CD 4
 (Refer to section 7.6)

- 1 FORMAT
- 2 SHOW FILE
- 3 COPY A → B
- 4 COPY ALL A → B
- 5 CARD DRV A / B
- 6 NEXT

- 1 CONFIRM
- 6 CANCEL

- 5 PROTECT ON/OFF
- 6 RETURN

- 1 CONFIRM
- 6 CANCEL

- 1 CONFIRM
- 6 RETURN

- 1 LOAD MENU
- 2 STORE MENU
- 6 RETURN

- 1 CONFIRM
- 6 CANCEL

SHIFT + COPY 8
 (Refer to section 7.9)

- 1 CONFIRM
- 6 CANCEL

SHIFT + CAL 7
 (Refer to section 7.10)

- 1 CAL ALL
- 2 TOTAL GAIN
- 3 EACH ITEM
- 4 CAL SIG ON/OFF
- 5 FRQ CORR ON/OFF
- 6 CAL CORR ON/OFF

- 1 INPUT ATT
- 2 IF STEP AMPTD
- 3 RBW SWITCH
- 4 LOG LINEAR
- 5 AMPTD MAG
- 6 PBW

SHIFT + LABEL 9
 (Refer to section 7.11)

- 1 MARK 1/2/3
- 2 SPACE
- 3 LABEL CLEAR
- 5 LBL DISP ON/OFF
- 6 RETURN

A.4 List of Messages

Error code	Message	Description
ERR 100:	CAL SIG ?	Calibration cannot be executed due to no calibration signal.
ERR 101:	?? RF ATT	An error was detected in the RF ATT calibration.
ERR 102:	?? IF AMP	An error was detected in the IF AMP calibration.
ERR 103:	?? RBW	An error was detected in the RBW SWITCH calibration.
ERR 104:	?? LINEAR	An error was detected in the LOG LINEARITY calibration.
ERR 105:	?? MAG	An error was detected in the MAG SWITCH calibration.
ERR 106:	?? GAIN	An error was detected in the TOTAL GAIN calibration.
ERR 110:	?? CORR DAT	FREQ CORR cannot be switched ON because FREQ CORR data broken (invalid).
ERR 111:	?? CORR DAT	Compensation data is not guaranteed because the total of frequency compensation value (frequency corr, antenna corr) is out of limits (7div).
ERR 120:	TG OUTPUT?	The automatic adjustment of TG ADJ cannot be executed because TG output signal is not detected.
ERR 121:	?? TG ADJ	An error occurs in the automatic adjustment of TG ADJ.
ERR 200:	NG SPAN 0	MKR→CF function cannot be executed because the zero-span mode is selected.
ERR 201:	NG SPAN 0	ΔMKR→SPAN function cannot be executed because the zero-span mode is selected.
ERR 202:	NG SPAN 0	MKR→CF STEP function cannot be executed because the zero-span mode is selected.
ERR 203:	NG SPAN 0	ΔMKR→CF STEP function cannot be executed because the zero-span mode is selected.
ERR 204:	NG SPAN 0	ΔMKR→CF function cannot be executed because the zero-span mode is selected.
ERR 205:	NG SPAN 0	FIXEDΔMKR function cannot be executed because the zero-span mode is selected.

**SPECTRUM ANALYZER
OPERATION MANUAL**

A.4 List of Messages

(cont'd)

Error code	Message	Description
ERR 206:	NG SPAN 0	SIGNAL TRACK function cannot be executed because the zero-span mode is selected.
ERR 207:	NG SPAN 0	OBW and ADJ functions cannot be executed because the zero-span mode is selected.
ERR 209:	NG SPAN 0	Window sweep mode cannot be selected because the zero-span mode is selected.
ERR 210:	NG SPAN 0	Power measurement cannot be executed because the zero span mode is set.
ERR 220:	NG LIN SCL	Noise/Hz function cannot be executed because the linear scale is selected.
ERR 221:	NG LIN SCL	dB down function cannot be executed because the linear scale is selected.
ERR 222:	NG LIN SCL	Frequency compensation function cannot be executed because the linear scale is selected.
ERR 223:	NG LIN SCL	Antenna compensation (dipole) function cannot be executed because the linear scale is selected.
ERR 224:	NG LIN SCL	Antenna compensation (log perd) function cannot be executed because the linear scale is selected.
ERR 225:	NG LIN SCLT	Antenna compensation (user) function cannot be executed because the linear scale is selected.
ERR 226:	NG LIN SCLT	Limit line cannot be displayed because the linear scale is selected.
ERR 227:	NG LIN SCL	PHS mode cannot be set because the linear scale is set.
ERR 228:	NG LIN SCL	RBW 1kHz, 300Hz or 100Hz cannot be set because the linear scale is set.
ERR 230:	10dB/div ?	OBW and ACP functions cannot be executed because the scale is not set to 10dB/div.
ERR 235:	RBW ?	Linear scale cannot be set because the RBW 1kHz, 300Hz or 100Hz is set.
ERR 270:	WIDE RBW ON	The RBW or VBW cannot be set to the input mode because the WIDE RBW is turned ON.
ERR 271:	WIDE RBW ON	Neither the Noise/Hz nor the power measurement cannot be made because the WIDE RBW is turned ON.

**SPECTRUM ANALYZER
OPERATION MANUAL**

A.4 List of Messages

(cont'd)

Error code	Message	Description
ERR 300:	WRITE ?	SIGNAL TRACK cannot be executed because the trace is not in the WRITE mode.
ERR 301:	WRITE ?	COUNTER cannot be executed because the trace is not in the WRITE mode.
ERR 302:	NG BLNK MD	OBW cannot be executed because the BLANK mode is set to the trace.
ERR 303:	NG BLNK MD	The third harmonics measurement cannot be executed because the BLANK mode is set to the trace.
ERR 304:	NG BLNK MD	The AM modulation factor measurement cannot be executed because the BLANK mode is set to the trace.
ERR 305:	NG TA BLNK	ACP cannot be executed because the BLANK mode is set to the trace A.
ERR 306:	NG IN AVG	SIGNAL TRACK function cannot be executed because the AVERAGE mode is in progress.
ERR 307:	NG TRACE	Power measurement cannot be executed because the BLANK mode or the VIEW mode is set to the trace.
ERR 308:	?? CORR DAT	The normalize cannot be turned ON because there is no data in the memory.
ERR 310:	NG MNL SWP	COUNTER function cannot be executed because the MANUAL SWEEP mode is selected.
ERR 311:	NG MNL SWP	SIGNAL TRACK function cannot be executed because the MANUAL SWEEP mode is selected.
ERR 312:	NG MNL SWP	OBW and ACP functions cannot be executed because the MANUAL SWEEP mode is selected.
ERR 313:	NG MNL SWP	Delay sweep mode cannot be selected because the MANUAL SWEEP mode is selected.
ERR 315:	NG MNL SWP	PHS mode cannot be set because the MANUAL SWEEP mode is set.
ERR 316:	NG MNL SWP	Power measurement cannot be executed because the MANUAL SWEEP mode is set.
ERR 320:	NG CNTR ON	MANUAL SWEEP function cannot be executed because the COUNTER operation mode is selected.

**SPECTRUM ANALYZER
OPERATION MANUAL**

A.4 List of Messages

(cont'd)

Error code	Message	Description
ERR 321:	NG CNTR ON	SIGNAL TRACK function cannot be executed because the COUNTER operation mode is selected.
ERR 330:	NG SIG TRK	dB DOWN function cannot be executed because the SIGNAL TRACK is in progress.
ERR 331:	NG SIG TRK	Continuous peak search function cannot be executed because the SIGNAL TRACK is in progress.
ERR 332:	NG N/Hz MD	dB DOWN function cannot be executed because the NOISE/Hz mode is selected.
ERR 333:	NG N/Hz MD	Continuous peak search function cannot be executed because the NOISE/Hz mode is selected.
ERR 336:	NG SIG TRK	The AVERAGE mode cannot be executed because SIGNAL TRACK is being executed.
ERR339:	NO PEAK	The peak list function cannot be executed because no waveform peak exists.
ERR 340:	NO PEAK	3D harmonic wave distortion cannot be obtained because the desired peak waveform does not exist.
ERR 341:	NO PEAK	AM accuracy cannot be obtained because the desired peak waveform does not exist.
ERR342:	BAD SET UP	ACP function cannot be executed because the incorrect setup data is set on the display screen.
ERR 358:	ANT CORR ON	NOISE/Hz function cannot be executed because the antenna compensation mode is selected.
ERR 359:	ANT CORR ON	Linear scale function cannot be executed because the antenna compensation mode is selected.
ERR 360:	ANT CORR ON	Units cannot be changed because the antenna compensation mode is selected.
ERR 362:	ANT CORR ON	Power measurement cannot be executed because the antenna correction mode is set.
ERR 365:	LMT LINE ON	Linear scale function cannot be executed because the limit line is displayed.
ERR 366:	T-DOM DATA ?	Limit line having T-DOMAIN data cannot be displayed because the F-DOMAIN is selected.

**SPECTRUM ANALYZER
OPERATION MANUAL**

A.4 List of Messages

(cont'd)

Error code	Message	Description
ERR 367:	F-DOM DATA ?	Limit line having F-DOMAIN data cannot be displayed because the T-DOMAIN is selected.
ERR 369:	LMT LINE ON	PHS mode cannot be set because the limit line is displayed.
ERR 370:	NG DELAY MD	SWP cannot be set to AUTO because Delay sweep mode is selected.
ERR 371:	NG DELAY MD	SWP cannot be set to MANUAL because Delay sweep mode is selected.
ERR 372:	NG DELAY MD	Window sweep mode cannot be selected because Delay sweep mode is selected.
ERR 375:	NG POWER	Power measurement result becomes over the scale.
ERR 376:	NG POWER	MANUAL SWEEP cannot be executed because power measurement mode is set.
ERR 377:	NG POWER	AVERAGE mode cannot be set because power measurement is selected.
ERR 380:	NG FAST SWP	Trace detector cannot be set except sampling detector because sweep time is selected 40ms or less.
ERR 381:	NG FAST SWP	MANUAL SWEEP cannot be executed because sweep time is selected 19ms or less.
ERR 400:	NO CARD	SAVE and RECALL functions cannot be executed because no memory card is installed.
ERR 401:	?? CARD ID	Memory card error due to out of the JEIDA Ver. 4.1 standard.
ERR 402:	?? CARD ID	Memory card error due to out of the JEIDA Ver. 4.1 standard.
ERR 403:	?? CARD ID	Memory card error due to out of the JEIDA Ver. 4.1 standard.
ERR 404:	?? CARD ID	Memory card error due to out of the JEIDA Ver. 4.1 standard.

Note: Error codes (400 to 423) are generated if memory card standards are out of JEIDA IC Memory Card Guide Line Ver. 4.1.

If an error code is generated and the memory card cannot be used correctly, contact to our service engineer.

**SPECTRUM ANALYZER
OPERATION MANUAL**

A.4 List of Messages

(cont'd)

Error code	Message	Description
ERR 405:	?? CARD ID	Memory card error due to out of the JEIDA Ver. 4.1 standard.
ERR 410:	CARD SIZE?	Memory card error due to incorrect memory card size.
ERR 411:	NOP CARD	Memory card error due to incorrect memory card specification (not supported).
ERR 412:	NOP CARD	Memory card error due to incorrect memory card specification (not supported).
ERR 413:	NOP CARD	Memory card error due to incorrect memory card specification (not supported).
ERR 414:	NOP CARD	Memory card error due to incorrect memory card specification (not supported).
ERR 420:	NO ATTR MEM	Memory card error due to attribute memory. (Access failed).
ERR 421:	?? FORMAT	Memory card error due to unmatched format type.
ERR 422:	CARD BATT ?	Memory card error due to dead battery.
ERR 423:	?? CARD RAM	Memory card RAM error.
ERR 500:	Internal error	Memory card internal error.
ERR 501:	Internal error	Memory card internal error.
ERR 502:	Internal error	Memory card internal error
ERR 503:	Too many files open	Three files or more were opened.
ERR 504:	Can't access directory	Directory was accessed.
ERR 505:	File is write protected	Write failed due to a read-only file.
ERR 506:	Card is write protected	Write failed due to a write-protected memory card.

Note: Error codes (400 to 423) are generated if memory card standards are out of JEIDA IC Memory Card Guide Line Ver. 4.1.

If an error code is generated and the memory card cannot be used correctly, contact to our service engineer.

**SPECTRUM ANALYZER
OPERATION MANUAL**

A.4 List of Messages

(cont'd)

Error code	Message	Description
ERR 507:	File already open	Desired file was already opened.
ERR 508:	No such file	Access failed due to non-exist file.
ERR 509:	File is full	Cannot store a file due to many files.
ERR 510:	Card is full	Cannot write a data because the memory card capacity is full.
ERR 511:	Bad file name	Incorrect file name was specified.
ERR 512:	Card type unmatched	Cannot copy a data due to the unmatched memory card.
ERR 513:	Bad file descriptor	Incorrect file descriptor was specified.
ERR 514:	File already exists	Same filename already exists.
ERR 515:	Permission denied	Permission denied file was accessed.
ERR 516:	Card format unknown	Memory card format is different type.
ERR 517:	File check sum error	The check sum data cannot be accessed.
ERR 518:	ID code unmatched	ID code of memory card cannot be matched.
ERR 519:	File type unmatched	File type to be recalled differs.
ERR 600:	DEVICE BUSY	Plotter was already operated.
ERR 601:	DEVICE BUSY	Printer was already operated.
ERR 605:	NO ACT DEV	Plotter cannot output a data due to no-handshake.
ERR 606:	NO ACT DEV	Printer cannot output a data due to no-handshake.
ERR 610:	??HANDSHAKE	Handshake error was detected during plotter output.
ERR 611:	??HANDSHAKE	Handshake error was detected during printer output.

**SPECTRUM ANALYZER
OPERATION MANUAL**

A.4 List of Messages

(cont'd)

Error code	Message	Description
ERR 700:	NG PHS MD	Linear scale cannot be set because the PHS mode is set.
ERR 701:	NG PHS MD	MANUAL SWEEP cannot be executed because the PHS mode is set.
ERR 702:	NG PHS MD	Limit line cannot be displayed because the PHS mode is set.
ERR 703:	NG PHS MD	Measurement window cannot be displayed because the PHS mode is set.
ERR 704:	NG PHS MD	Power measurement cannot be executed because the PHS mode is set.
ERR 705:	SYNC CS-ID	Delay sweep mode cannot be set because the SYNC CS-ID trigger is set.
ERR 706:	SYNC CS-ID	Zoom mode cannot be set because the SYNC CS-ID trigger is set.
ERR 707:	NG SYNC	SYNC CS-ID cannot be set because the ID cycle is not measured.
ERR 708:	NG SYNC	ID measurement cannot be started because the ID cycle is not measured.
ERR 709:	ID MEAS ON	Trigger cannot be changed because the ID measurement function is set.
ERR 710:	ID MEAS ON	Sweep time cannot be changed because the ID measurement function is set.
ERR 711:	NOT FOUND	There is no PHS channel that matches with the ID trigger.
ERR 712:	NG ID MKR	ID marker cannot be set because the ID measurement function is set.
ERR714:	NG PHS MD	The multi-marker list cannot be displayed because now is in the PHS mode.
ERR 715:	NG PHS MD	Peak list cannot be displayed because now is in the PHS mode.
ERR 716:	SWEEP TIME ?	ID marker or Zoom mode cannot be set because the sweep time is short than 4.5 ms.
ERR 717:	SWEEP TIME ?	ID list cannot be displayed because the sweep time is short than 4.5 ms.
ERR 718:	SWEEP TIME	Sweep time cannot be shortened than 4.5 ms because this unit is in the ID marker mode or in the zoom mode.

**SPECTRUM ANALYZER
OPERATION MANUAL**

A.4 List of Messages

(cont'd)

Error code	Message	Description
ERR 731:	NG PEAK LST	PHS mode cannot be set because now is in the peak list mode.
ERR 732:	NG PEAK LST	Others than the single sweep cannot be set because now is in the peak list mode.
ERR 733:	NG PEAK LST	Functions using the marker cannot be executed because now is in the peak list mode.
ERR 734:	NG PEAK LST	TV monitor screen cannot be set because now is in the peak list mode.
ERR 750:	NG PICTURE	Peak list cannot be displayed because the TV monitor screen.
ERR 900:	NO LOCK DET	Center frequency setting cannot be performed correctly.
ERR 901:	OVERLOAD!!	Overloaded signals were input.

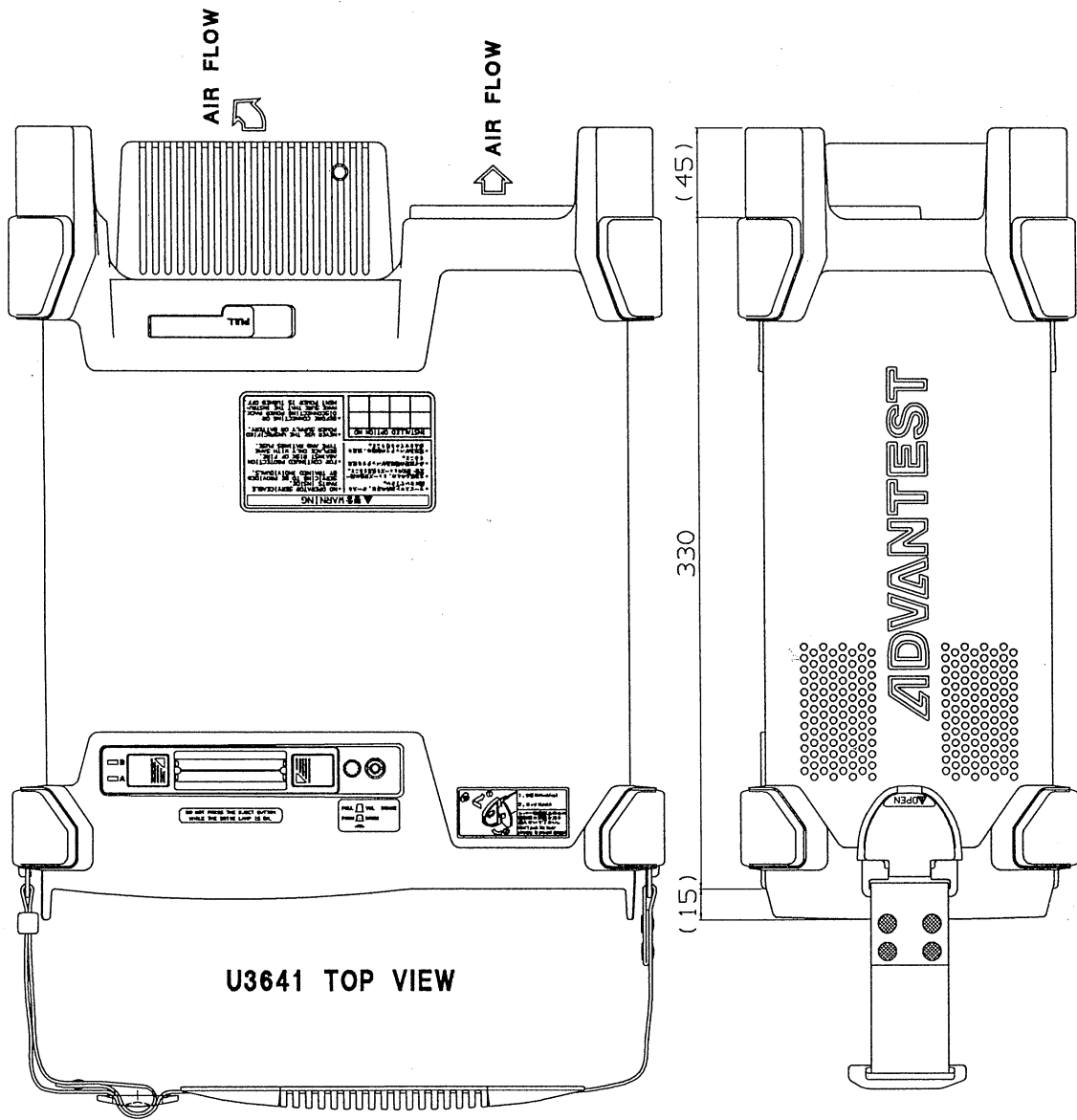
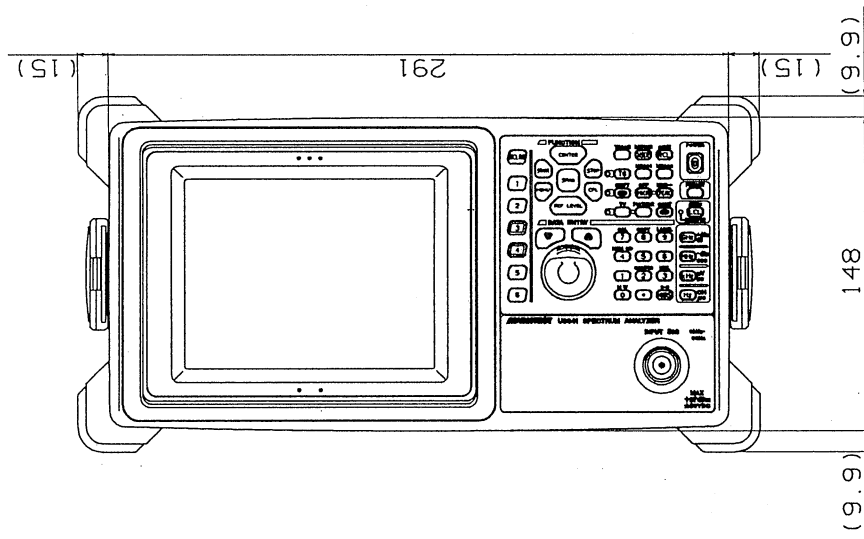

Unit : mm

CAUTION

This drawing shows external dimensions of this instrument.

The difference in products and options used can cause a change in the appearance of the instrument.

DIMENSIONAL OUTLINE DRAWING

ALPHABETICAL INDEX

	[Δ]		
Δ MARKER		7-26	
	[1]		
1 dB gain compression point		6-5	
	[A]		
AC Operation		2-6	
AC power requirements		2-7	
AC/DC adapter		2-6,	
		2-5	
Accessories of List		1-3	
ACP GRAPH		6-35	
ACP POINT		6-34	
Adjacent Channel Leakage Power (ACP) Measurement		6-32	
Adjacent spurious		A-4	
Adjustment of TV Monitor Screen		8-5	
AM Signal Analysis		6-16	
Analyzer Control Key Functions		5-1	
Analyzer Features and Specifications		1-1	
ANT C		7-63	
Antenna Factor Correction		7-89	
ATT		6-3	
AUTO		9-21	
Average display noise level		6-5	
Averaging Mode		7-22	
	[B]		
Bandwidth Accuracy		A-6	
Bandwidth Selectivity		A-6	
Bandwidth Switching Accuracy		A-6	
Battery Check Function		7-80	
Battery Operation		2-6	
BLANK mode		7-20	
BRIGHT		11-55	
Burst Signal Spectra		6-43	
	[C]		
Calculation Modes		7-24	
Calibration Function		7-83	
Calling from the memory card		9-9	
			CARRIER
			11-55
			Carrier signal level measurement
			6-41
			Cautions in Handling Memory Card ..
			5-29
			Center channel
			11-54
			Center Frequency
			7-2
			Channel AUTO
			11-54
			Channel input
			11-54
			Channel setup
			8-4,
			9-1,
			9-5
			Channel setup I
			11-31
			Channel setup II
			11-31
			Channel Table Allocation
			9-19
			Channel table in China
			9-31
			Channel table in east Europe
			9-33
			Channel table in France
			9-36
			Channel table in Italy
			9-40
			Channel table in Japan
			9-20
			Channel table in Korea
			9-41
			Channel table in Malaysia
			9-43
			Channel table in Singapore
			9-43
			Channel table in U.S.A
			9-43
			Channel table in west Europe
			9-49
			Channel Table List by Country
			9-20
			Channel table of BS
			9-18
			Channel table of CS (Japan)
			9-19
			Channel table of UHF
			9-17
			Channel table of VHF
			9-17
			Channel Table Title by Band
			9-17
			Checking Accessories
			2-1
			Checking the fuse
			2-10
			Cleaning
			2-4
			Clear Screen
			10-7
			Color definition window screen
			7-15
			COLOR NTSC/PAL
			11-55
			Color setting window
			7-18
			Color table mode
			7-17
			Command Syntax (Listener)
			11-8
			Communication port close setting
			5-36
			Communication port open setting
			5-36
			Communication Port Setting
			5-34
			Condition of Memory Card
			5-18

**SPECTRUM ANALYZER
OPERATION MANUAL**

Alphabetical Index

READ OUT	11-55	Sweep mode setup	7-11
Rear Panel	3-6	Sweep Time	6-3
RECALL DEFINE menu screen	5-28	Sweep Time for 2 seconds	10-9
Recall Function	7-68	SWP	6-3
Reference Level	7-4, A-2		
Reference level setting range	7-4	[T]	
Relation between screen grid and data points	11-18	Talk only /address	5-11
Residual response	6-9	Television Carrier Signal Measurements	6-36
RS-232 Interface Communication	7-77	Third order intermodulation distortion	6-8
RS-232 Remote Control Function	5-30	Third order intermodulation Distortion measurement	6-14
RS-232 Remote Programming Examples	5-39	Through-line	10-6
RS-232 Specifications	5-31	TINT	11-55
		To Use Memory Card	5-20
[S]		Top Panel	3-8
Satellite Broadcast Signal C/N Measurement	6-39	Trace accuracy codes	11-18
Save Function	7-66	TRACE Functions	7-19
SAVE function menu	5-23	Trace Modes	7-20
Saving in the memory card	9-9	TRACKING GENERATOR Function ..	10-1
Second order harmonic distortion	6-7	TRIGGER position	7-9
Service Request (SRQ)	11-25	TV BAND	11-54
Service request ON/OFF codes	11-25	TV CHANNEL Function	9-1
Setting the Analyzer's GPIB Address ..	11-7	TV Channel Table	9-16
Setup mode	7-42	TV MODE	11-54
Shipping	2-4	TV mode and scan line number	9-16
Sideband level	6-19	TV MONITOR Function	8-1
Signal line termination	11-5	TV standard mode	9-16
Single Sweep	7-47	TVSTD	11-55
Softkey Menu	A-9		
Softkey menu and softkeys	5-1	[U]	
Spectrum Analyzer Parameters Common to All Measurements	6-1	U3641 specifications	13-1
Spurious response	6-8, A-4	U3641N1 specifications	13-8
		Usage of Tracking Generator	10-2
Standard accessories	2-1	User channel setup	9-7
Start channel	11-54	User table screen	9-9
START, STOP Frequencies	7-3	User table setup	9-6, 11-31
Status byte information	5-47	User-defined display	7-56
Status register bit assignments	11-25	User-Defined Functions	7-56
Stop bit setting	5-35	Utility Functions	7-89
Stop channel	11-54		
Storage the Analyzer	2-4		

SPECTRUM ANALYZER
OPERATION MANUAL

Alphabetical Index

[V]	
V/A Measurement	6-37
VBW	6-2
Video Printer Output	5-17
VIEW mode	7-20
VSWR	A-7
[W]	
WP	7-62
WRITE mode	7-20
[Y]	
YIG-tuned Oscillator	A-7
[Z]	
Zero Spam	A-3

Part 2
U3641PHS
PHS-ID Demodulation Function
OPERATION MANUAL

TABLE OF CONTENTS

1. Products overview	1-1
1.1 Overview	1-1
2. Accessory (sold separately)	2-1
2.1 Accessories	2-1
3. Panel	3-1
3.1 Front panel	3-1
3.2 Screen	3-3
4. Measurement example	4-1
4.1 To measure the up and down levels of 12 chs (1898.45 MHz)	4-1
4.2 To ID-trigger at a specified base station	4-3
4.3 To measure burst error rate of the specified base station.	4-7
4.4 To display the list of base stations of specified users' ID codes.	4-8
5. Explanation of Functions	5-1
5.1 Outline	5-1
5.2 Soft menu configuration	5-2
6. GPIB	6-1
6.1 GPIB code list	6-1
6.2 Output format	6-5
6.3 Status list	6-6
6.4 Examples of program	6-7
7. Specifications of performance	7-1
APPENDIX	A-1
A.1 PHS carrier frequency assignment)	A-1
A.2 Memory card CSV type	A-2
A.3 Soft menu list	A-5
A.4 Display message list	A-6

LIST OF ILLUSTRATIONS

No.	Title	Page
2-1	Accessories	2-2
5-1	PHS Mode Screen	5-2
5-2	Display of ID list	5-3
5-3	Trigger menu	5-4
5-4	ID trigger mode	5-5
5-5	List setup menu	5-7
5-6	ID marker	5-12
5-7	Cumulative operation menu	5-13
6-1	Output format of ID list	6-5
6-2	Output format of ID marker	6-5
6-3	Output format of burst error measurement result	6-5

1 CHAPTER Products overview

This chapter provides a brief explanation of PHS-ID demodulation function.

1.1 Overview

U3641PHS has the PHS-ID demodulation function to demodulate logic control channel signal of personal handy-phone system (PHS) and to detect base station ID number. Combined with spectrum analyzer signal analyzing function, it displays signal level and ID code on the waveform measurement screen.

■ Functions

- ID trigger Starts sweeping after agreement between specified ID code and measurement-demodulated ID code. ID code can trigger-register the input from keys and the measurement data.
- ID list Displays the list of measurement results.
Display items: CI, CS-ID, PS-ID, level, time between IDs.
Display type: Hexadecimal Selection of right/left alignment.
- ID marker Puts the cursor on a signal on the measurement screen and displays ID code of the signal.
- Channel setting Can set the measuring frequency by PHS channel (carrier number).
- Level measurement Obtains median value, average value, maximum and minimum value.

2. Accessory (sold separately)

This chapter provides an explanation of accessories for PHS-ID demodulation function.

2.1 Accessories

■ Antenna for PHS

Type	<u>3XAK0618</u>
Frequency	1895 to 1918MHz
Antenna type	$\lambda/2 \times 2$ steps collinear
Directivity	Non-directivity in a horizontal surface
Impedance	Nominal impedance 50 Ω
V.S.W.R	1.5 or less
Gain	4 \pm 1dBi

■ Connector for antenna

It is used when antenna for PHS is already prepared.

Type	<u>4XAM0001</u>
Connector	SMA J-J
Pass losses	Under 0.1 dB

■ Magnet stand

It is used to fix antenna for PHS to car roof, etc.
Feeder 3 m with NP connector

■ Coaxial flexible cable

It is used as an extension cable of antenna. A conversion adaptor (NP-SMAJ) is needed for the connection with RF field analyzer.

Type	<u>TCF358HAA1500, TCF358HAA2000</u>
Connector	SMA
Cable length	1.5 m (TCF358HAAA1500) 2m (TCF358HAAA2000)

PHS-ID DEMODULATION FUNCTION

2.1 Accessories

- Memory card
It is used to save setting/measurement data.

Type/capacity	A09507/64KB A09508/256KB A09509/2MB
Memory type	SRAM

- Band-pass filter
It controls unwanted signal level such as television signal.

Type	A04210
Connector	NP-NJ
Pass losses	typ. 1 dB (1895 to 1918MHz)

- Conversion adaptor
NP-TNCJ N plug — TNC jack
NP-SMAJ N plug — SMA jack

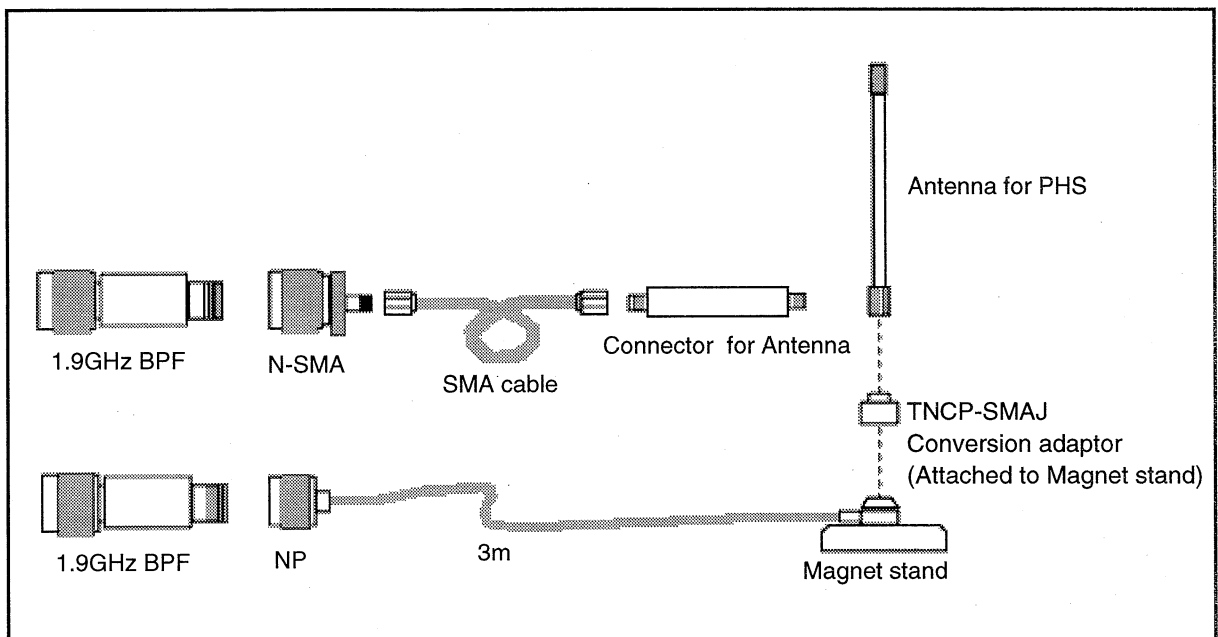

Figure 2-1 Accessories

3. Panel

This chapter provides an explanation of front panel and basic display screen.

3.1 Front panel

Two exclusive key switches are set to operate PHS-ID demodulation function.

- (1) PHS key Enters into PHS-ID demodulation mode (hereafter PHS mode). In the PHS mode, soft menu of PHS mode is displayed. In the PHS mode selected, LED lamp lights up.
- (2) AUTO key The measurement is performed under the specified conditions and the measured results are stored in the memory card.

The following keys have additional changes of functions to the standard specifications.

- (3) CENTER key Selects input mode of the center frequency. Setting can be performed by frequency and channel (carrier number).
- (4) MEAS2 key The function is changed with PHS mode ON/OFF. In PHS mode, functions such as ID-MKR function, median computation, and average value are selected.

In ID code input, FUNCTION keys are assigned to hexadecimal digits, A, B, C, D, E, and F.

- A : CENTER
- B : STOP
- C : CPL
- D : REF LEVEL
- E : MENU
- F : START

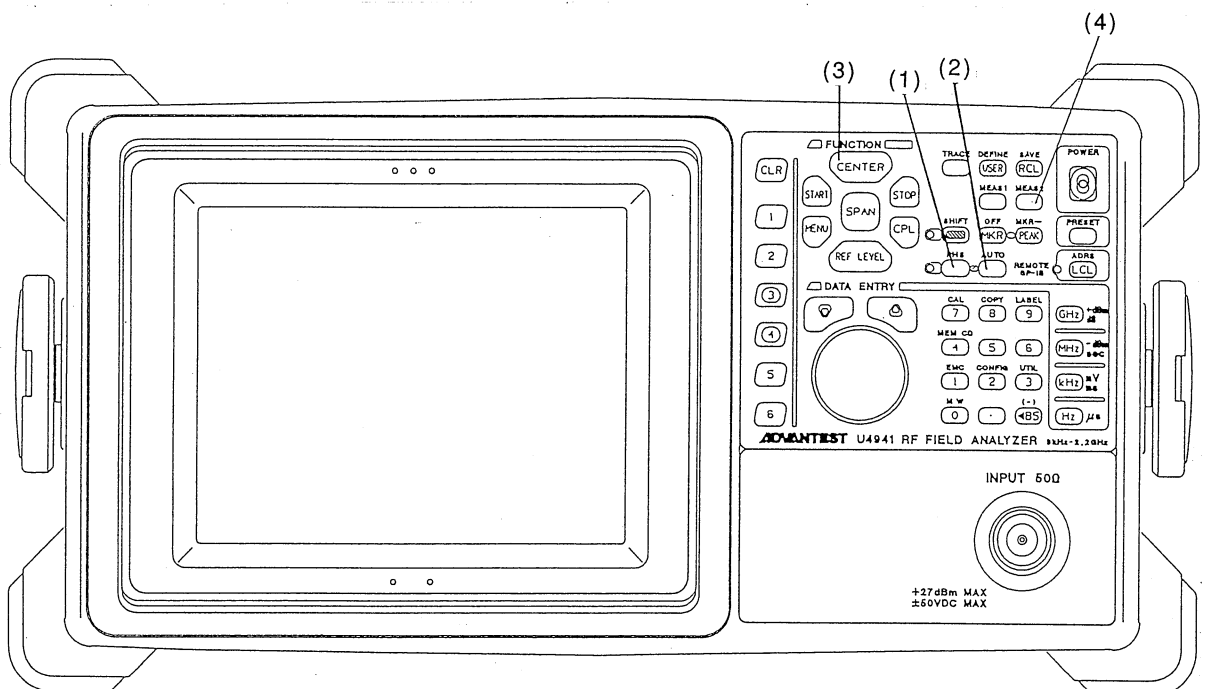

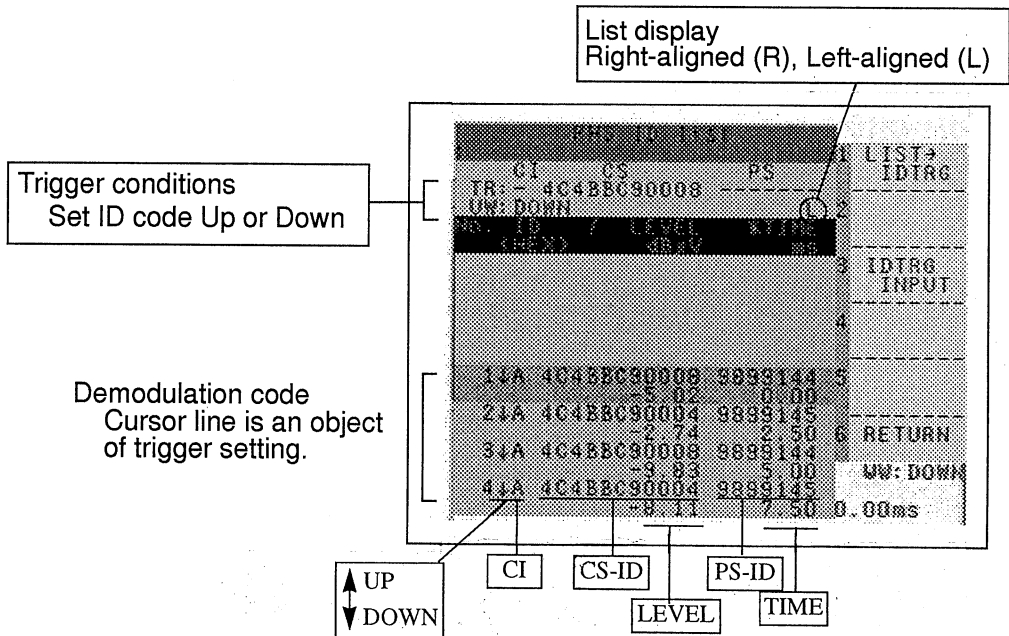

■ In the case of DISP IDI ON

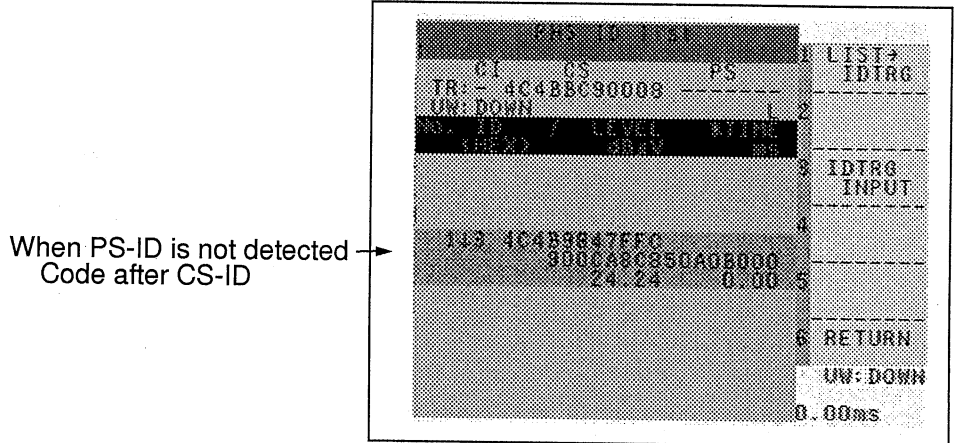
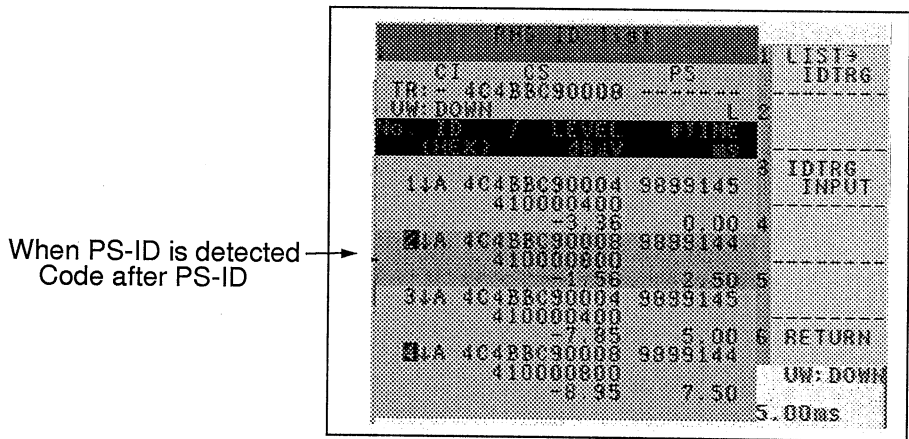

PHS-ID DEMODULATION FUNCTION

3.2 Screen

■ DISP CRC ERR OFF

When CRC error is detected, code is not displayed. (-----) is displayed.

CI	CS	PS	LIST	IDTRG
TR:	4C4B8C90008			
UM:	DOWN			
[Solid black bar]				
[Solid black bar]				
1A	4C4B8C90004	9899145		
2A	-----	0.00		
3A	-----	5.00		
4A	-----	10.00		
4A	4C4B8C90004	9899145		4.03ms

■ DISP CRC ERR ON

Even when CRC error is detected, code display is performed. "*" is displayed at the end of the code to show CRC error.

CI	CS	PS	LIST	IDTRG
TR:	4C4B8C90008			
UM:	DOWN			
[Solid black bar]				
[Solid black bar]				
1A	4C5B8C94004	9899145*		
2A	4C4B8C90004	9899145		
3A	4C4B8C90004	9899145*		
4A	4C5B8C90008	9899146*		
5A	4C4B8C90004	9899145		
6A	4C4B8C90004	9899145		
4A	4C4B8C90004	9899145		46.79ms

4.1 To measure the up and down levels of 12 chs (1898.45 MHz)

4. Measurement example

This chapter provides an explanation of PHS-ID demodulation functions measurement with examples.

4.1 To measure the up and down levels of 12 chs (1898.45 MHz)

- (1) Set channel.

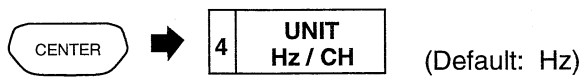

Each time it is pressed, the setting is switched alternately. Select [CH] here.

Input of 12ch: (1) (2) Enter key (Hz) or (kHz) or (MHz) or (GHz)

- (2) Select (ON) pre-amp according to the input level.



Each time it is pressed, the setting is switched alternately.

- (3) Enter into PHS mode.

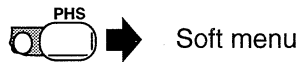

1	ID LIST & SET
2	TRIGGER VIDEO
3	SWEEP TIME
4	DSP LINE ON / OFF
5	LIST SETUP
6	PHS OFF

PHS-ID DEMODULATION FUNCTION

4.1 To measure the up and down levels of 12 chs (1898.45 MHz)

- (4) Set up list display (measurement result display).

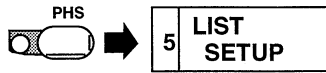

- The followings are set up to perform the up and down measurement.

PHS List Setup

```

Trigger ID      :
CS-ID Align    :
Sort           :
Cont Meas      :
Disp CRC ERR   :
Disp ID I      :
ID Filter      :
UW           :
UP DOWN        :
UP&DOWN     :
    
```

Move the cursor to [UW] with

Select [UP&DOWN] with

- (5) Return to PHS menu screen.

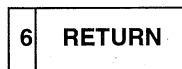

- (6) Display measurement results.



PHS ID LIST			
CI	CS	PS	
IB	- 4C4B9840010	---	
UW: DOWN			L
ID	ID (HEX)	LEVEL (dB)	*TIME (s)
1	A 4C4B9840010	989940E	
		34.90	0.00
2	A 4C4B9840010	989940E	
		31.15	5.00
3	A 4C4B9840010	989940E	
		34.97	10.00
4	A 4C4B9840010	989940E	
		34.90	15.00
5	A 4C4B9840010	989940E	
		34.83	20.00

4.2 To ID-trigger at a specified base station

Specified base station number (self-supporting system)

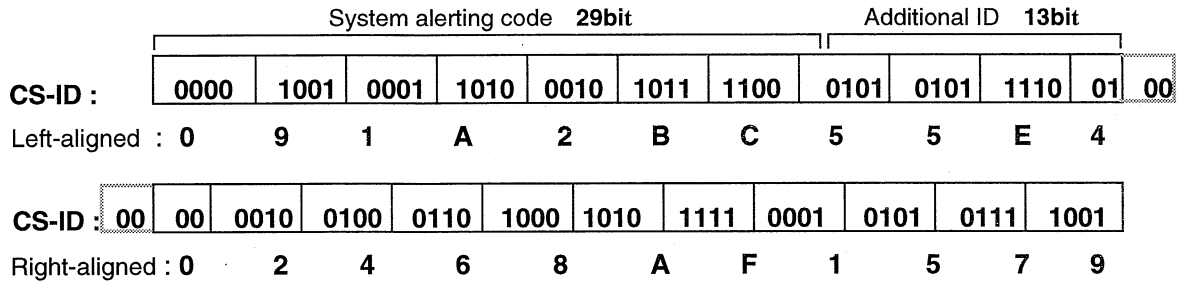

- (1) Set frequency or channel.

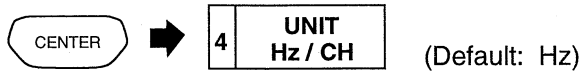

When left aligned,
LSB is 0, 4, 8, C

When right aligned,
MSB is 0, 1, 2, 3

- (2) Select (ON) pre-amp according to the input level.

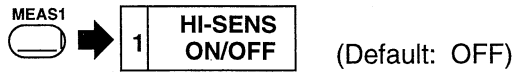

- (3) Enter into PHS mode.



- (4) Select an input format of the specified base station and a list display format.

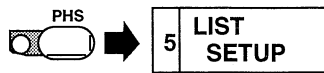

- ① Trigger ID : CI ... OFF
CS ... ON
PS ... OFF
UW ... DOWN

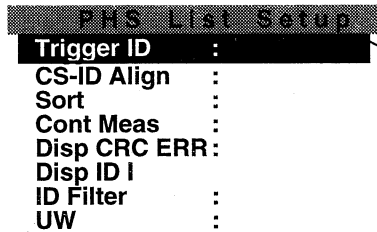

Move the cursor with

Move it with

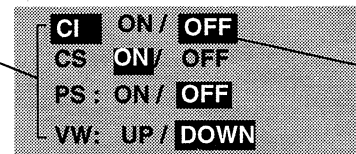

Select it with 1

PHS-ID DEMODULATION FUNCTION

4.2 To ID-trigger at a specified base station

Select an input and a display format.

- ② CS-ID Align : LEFT or RIGHT
 - ③ Sort : TIME or LEVEL
 - Cont Meas : On or OFF
 - Disp CRC ERR: On or OFF
 - Disp ID I : On or OFF
 - ID Filter : On or OFF
 - UW : UP or DOWN or UP&DOWN
- Refer to page 5-7 for details

Return to PHS menu screen with  .

- (5) Input the specified base station number.

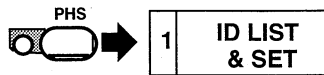

There are 3 ways to input it.

- ① To select ID from the measured results (list display) in the list to trigger.

PHS ID List			
CI	CS	PS	
TR	-	4C4B9840010	-----
UW: DOWN			
ID	ID	LEVEL	TIME
(HEX)	dBm		ms
1	A	4C4B9840010	989940E
		34.90	0.00
2	A	4C4B9840010	989940E
		31.15	5.00
3	A	4C4B9840010	989940E
		34.97	10.00
4	A	4C4B9840010	989940E
		34.90	15.00
5	A	4C4B9840010	989940E
		34.83	20.00

Move the cursor to a base station to specify with  .

Cursor line

Pressing  sets ID shown in the cursor line to trigger.

4.2 To ID-trigger at a specified base station

- ② To input with the ten keys and the function keys.

Use numeric keys for 0 to 9 of hexadecimal. The function keys are assigned to A- F as follows.

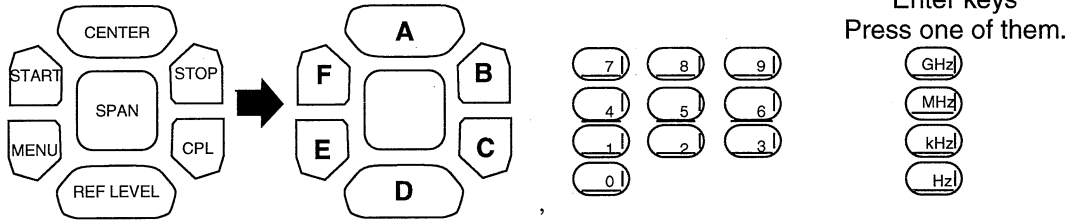

CS-ID Align: In the case of RIGHT

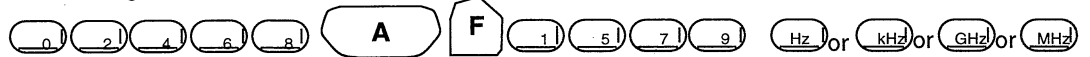

- ③ To specify a signal from the measurement screen with ID marker and to trigger ID code of the signal.

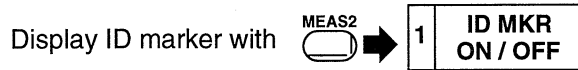

Move the cursor with and specify the signal.

The signal ID code is displayed as shown in the figure.

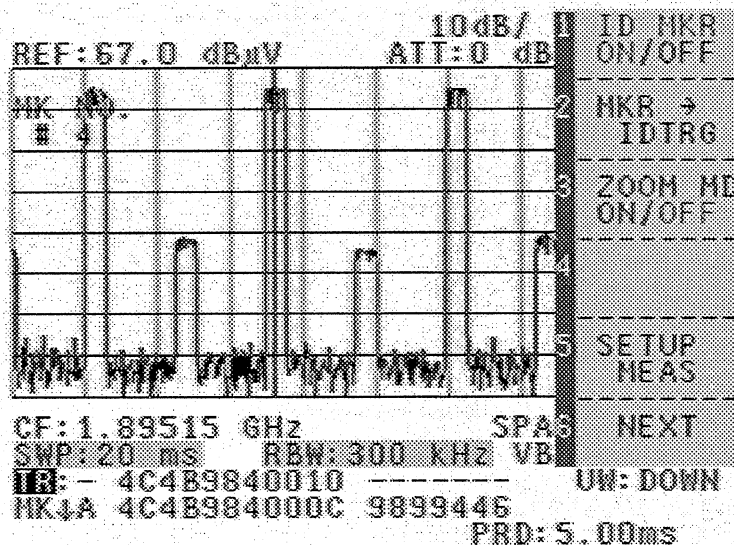
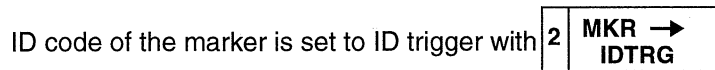

PHS-ID DEMODULATION FUNCTION

4.2 To ID-trigger at a specified base station

- (6) Return to PHS menu screen.



- (7) Select ID in the trigger selection mode.



CAUTION!

When the specified base station triggers, Sync CS-ID trigger can be used as well. Sync CS-ID trigger is kept on at the base station cycle even if trigger cannot be detected because of the specified base station signal level down or interference.

4.3 To measure burst error rate of the specified base station.

4.3 To measure burst error rate of the specified base station.

- (1) Set frequency or channel.

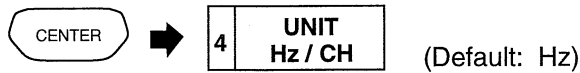

- (2) Select (ON) pre-amp according to the input level.



- (3) Input the specified base station.

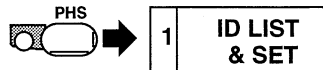

CAUTION!

1. When CS-ID has already been input as trigger ID, the measurement is performed to the base station.
2. As the burst error rate measurement is performed based on the specified base station cycle, the measurement continuity may be lost by setting wrong cycle with low level or interference wave. Refer to the setting cycle shown in the lower right of the screen.

- (4) Select burst error from MEAS 2 menu.

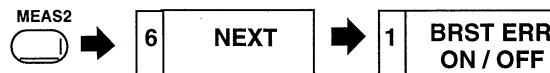

- Input measurement number of times with ten keys. (Default 10 times)

- Select when measurement is restarted.

PHS-ID DEMODULATION FUNCTION

4.4 To display the list of base stations of specified users' ID codes.

4.4 To display the list of base stations of specified users' ID codes.

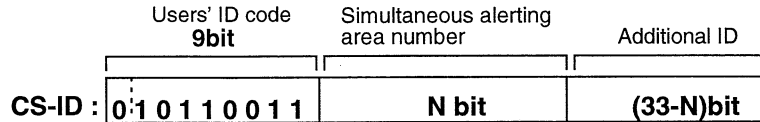

- (1) Set frequency or channel.

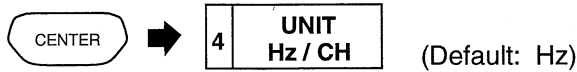

- (2) Select (ON) pre-amp from the input level.

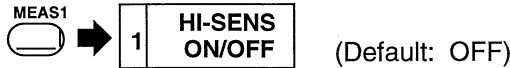

- (3) Enter into PHS mode and set up the list display.

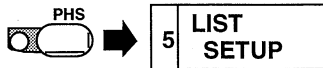

Set up as follows.

UW : DOWN Detect the down channel.

ID Filter : ON Detect only the data set at

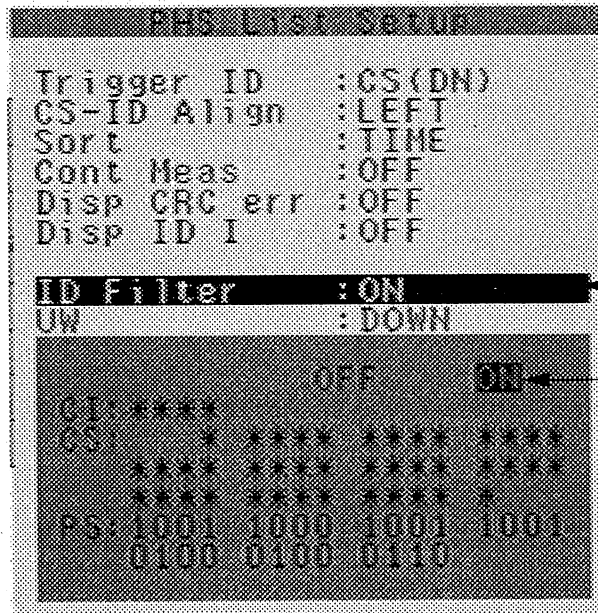

Move the cursor with

Specify with .

Input user's ID number.

Move the cursor with

Note:
"*" means 0 or 1.

Input of ten keys for *,
 of ten keys for 0,
and of ten keys for 1.

4.4 To display the list of base stations of specified users' ID codes.

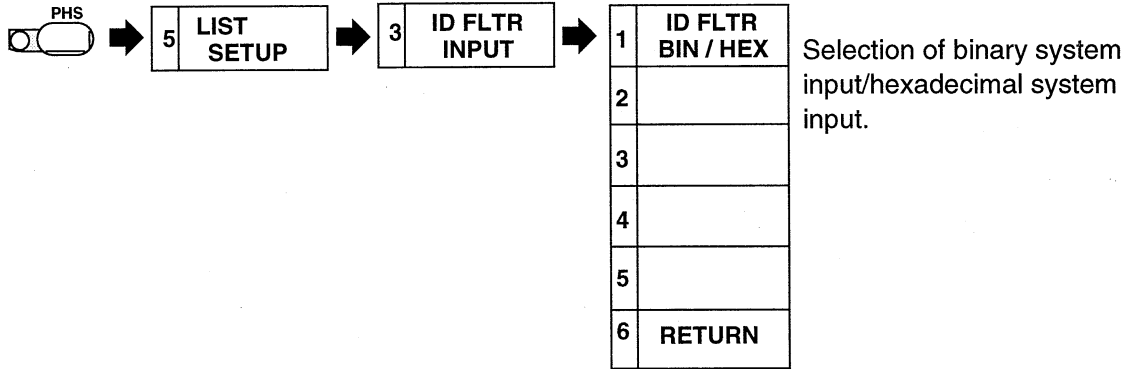

① CS : 0 **■** * * * * * * * * * * * * * * * *
 Binary (BIN) input 1

1 ID FLTR BIN / HEX Select HEX input.

② CS : 0 **■** * * * * * * * * * * * * * * * *
 Hexadecimal (HEX) INPUT B



③ CS : 0 1 0 1 1 **■** * * * * *



④ CS : 0 1 0 1 1 0 0 1 1 * * * * *

(4) Return to PHS basic menu.

6 RETURN , 6 RETURN

Hereafter, displaying ID list with left-aligned, only the codes of CS-ID with 59 at the head remain.

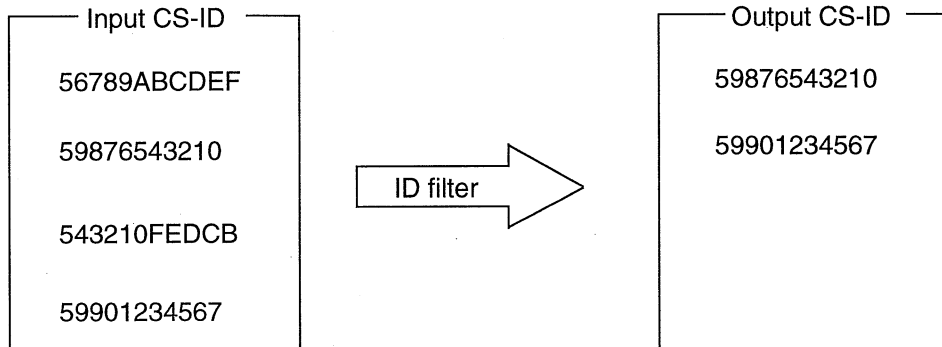

PHS-ID DEMODULATION FUNCTION

4.4 To display the list of base stations of specified users' ID codes.

■ ID list

The creation of list:

Create ID list each time after the completion of sweep. In order to get a match between measurement waveform data and list data in FREE RUN trigger mode, use SINGLE sweep mode.

Level measurement:

Level in ID list shows 1 center point level of the slot.

The level is calculated from waveform data. Therefore, the point data outside the scale range cannot be measured.

RBW Use it with more than 300 kHz.

swp time Use it with less than 400 ms. However, use it with under 100 ms when burst waveforms are adjacent on the screen. (due to horizontal axis resolution)

Time display on the list:

Time differences between slots UW-detected are displayed. When the specified base station slot is UW error in Sync CS-ID mode, time is not displayed.

Data number:

Maximum is 300. Data after 301 are junked.

■ ID marker

ID marker is positioned for the display based on ID list. The marker cannot be moved to undemodulatable signal. Also, when the trigger mode is FREE RUN, the display waveform and ID marker are not matched.

5. Explanation of Functions

This chapter provides an explanation of PHS-ID demodulation functions.

5.1 Outline

The functions are as follows,

- (1) To set and combine optical CI/CS-ID/PS-ID code as a sweep trigger.
- (2) To set frequency with channel input corresponding to PHS carrier number.
- (3) To demodulate PHS channels successively and detect signals by auto-scan function.
- (4) ID list function displays ID code of measured signal, level, and relative time.
 - To sort time and level in order for the list display.
 - To select right-aligned or left-aligned in hexadecimal for ID code display.
 - To display only the signals with over the specified level by using the display line.
 - To display only wanted ID-code signals from measurement signals by using ID filter function.
- (5) ID marker function displays ID code of measurement signal.
 - To set ID marker value to ID trigger.
- (6) To measure a wanted signal in minimum sweep time by using ZOOM function.
- (7) To measure the down CS-ID cycle.
- (8) To perform cumulative operation with measurement data.
 - Measurement of down CS burst error rate
 - Median value processing of down CS receiving level
 - Average value processing of down CS receiving level
 - Maximum and minimum values processing of down CS receiving level

PHS-ID DEMODULATION FUNCTION

5.2 Soft menu configuration

5.2 Soft menu configuration

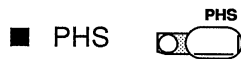

Pressing this key enters into PHS mode, and the screen like Fig. 5-1 appears. LED lamp lights to show it is PHS mode.

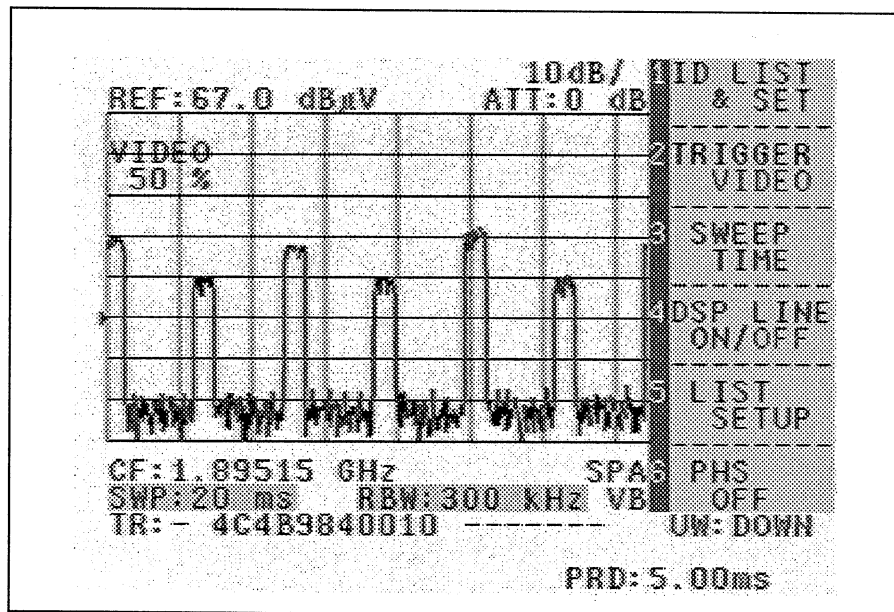

Figure 5-1 PHS Mode Screen

In PHS mode, the followings are set.

- Frequency span to zero span.
- Display range to 8 div.
- Level unit to dB μ V.

Note 1: Manual mode cannot be set in PHS mode.

2: Limit line function cannot be used in PHS mode.

3: In the PHS mode, use the trace A mode for saving the ID list or for using the IM marker.

4: When frequency span is set to other than 0, PHS mode is released.

1 ID LIST & SET

ID list of signal measured and demodulated in 1 sweep time is shown. Fig. 5-2 shows an example.

Display of ID LIST

It shows the list of data which is processed in burst, error, median, average value, and maximum/minimum modes ON. When you want to display ordinary ID list, set these modes to OFF.

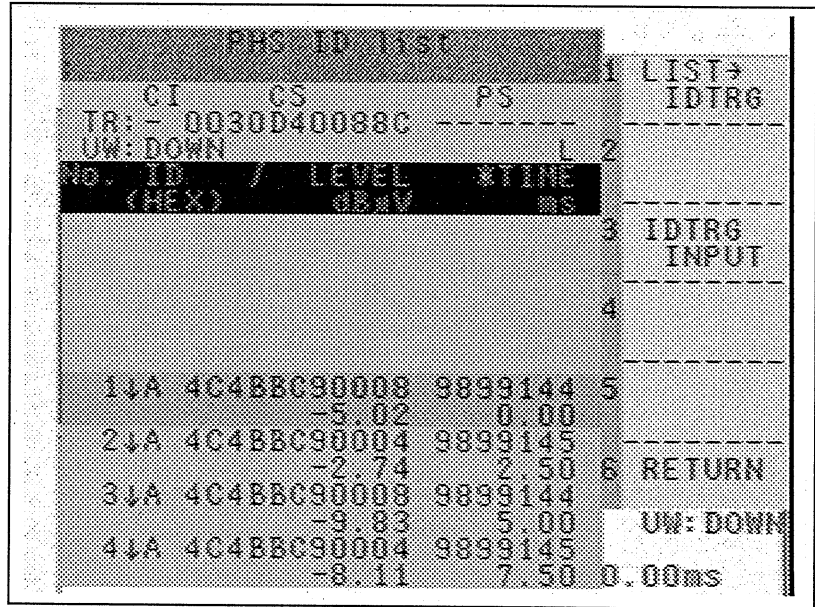

Figure 5-2 Display of ID list

1 LIST → IDTRG

Sets ID code displayed on the cursor line of ID list to ID trigger. However, the code with CRC/UW error cannot be set to the trigger.

3 IDTRG INPUT

Becomes ID trigger ID input state. Pressing this key again releases the input state. After completing ID input, be sure to release the input state. CS-ID and PS-ID numerical value must be input with hexadecimal number. Press the unit key to define input data. Press only the unit key for CI/CS/PS input switching.

Note: During inputting ID number, ordinary keys cannot be operated.

PHS-ID DEMODULATION FUNCTION

5.2 Soft menu configuration

Panel key and numeric value input
 Use numeric value key for 0-9 of hexadecimal number.
 Function keys of A-F are assigned clockwise.

- A = CENTER
- B = STOP
- C = CPL
- D = REF LEVEL
- E = MENU
- F = START

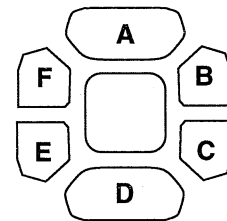

6 RETURN

Finishes displaying ID list.

2 TRIGGER VIDEO

Selects trigger mode.

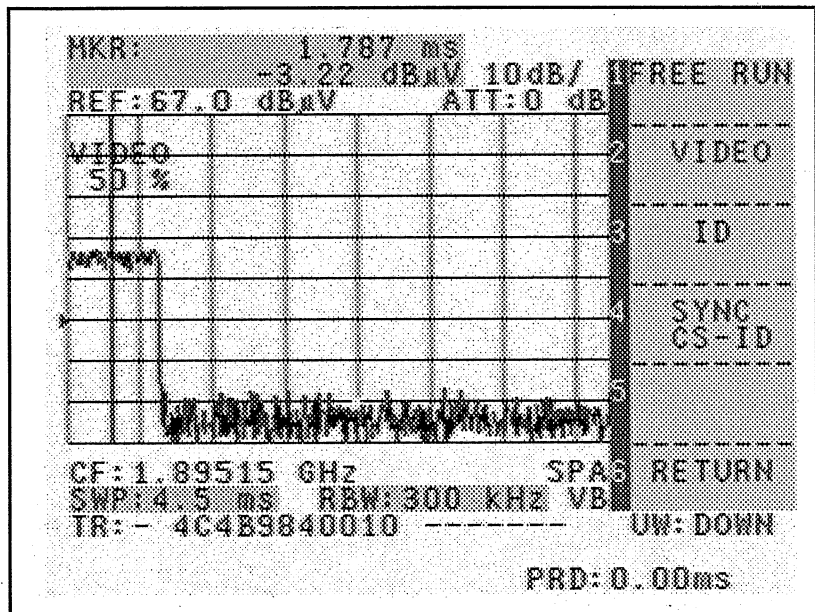

Figure 5-3 Trigger menu

1 FREE RUN

Sets the trigger mode to FREE RUN.

2 VIDEO

Sets the trigger mode to VIDEO.

3 ID

Sets the trigger mode to ID.
ID code which is set now is displayed on the screen as shown in Fig. 5-4. When the trigger mode is set to ID, "TR" character is displayed inversely.

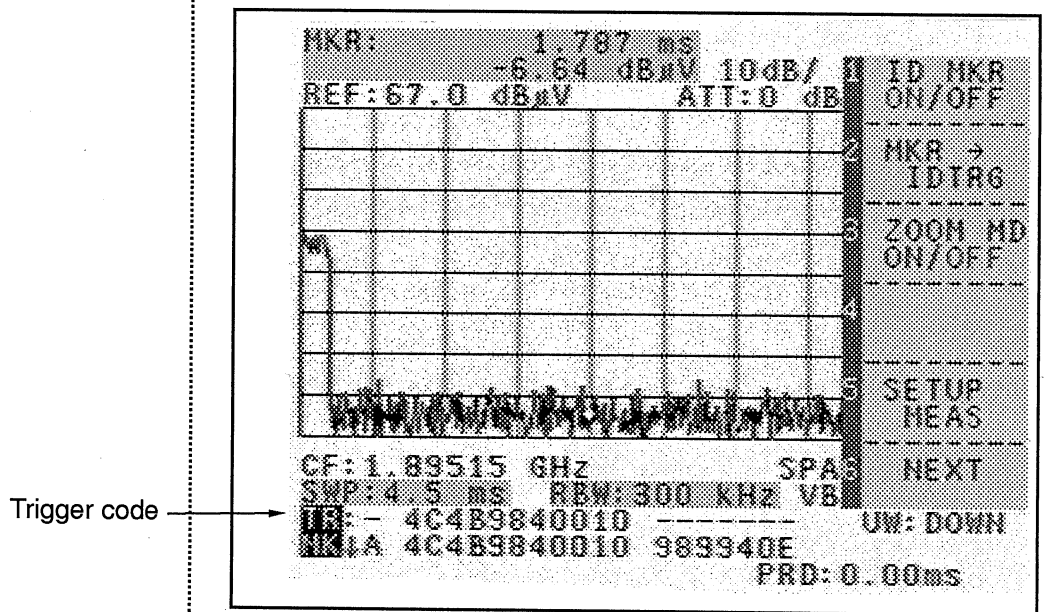

Figure 5-4 ID trigger mode

4 SYNC CS-ID

Sets the trigger mode to SYNC CS-ID.

The functioning of SYNC CS-ID

Generates internal trigger signal synchronizing to the set CS-ID (DOWN) cycle.

Specified ID signal can be observed even if ID could not be detected because of the signal level down, etc.

The delay time for changing the display position can be set in SYNC CS-ID mode.

The range of the setting is the minimum value to ID cycle time.

Minimum value:

35ns at the condition of sweep time < 4.5ms

50ns at the condition of sweep time ≥ 4.5ms

PHS-ID DEMODULATION FUNCTION

5.2 Soft menu configuration

CAUTION!

1. *Confirm that ID cycle is measured correctly before setting SYNC CS-ID.
If ID cycle cannot be measured, SYNC CS-ID trigger cannot be set.*
2. *When ID demodulation cannot be performed for a long time due to measurement accuracy of cycle, the display position of observation signal is changed.*
3. *Use the trigger conditions with CS-ID (DOWN). If (UP), it becomes (DOWN) forcibly.*
4. *Delay sweep and zoom function cannot be set in SYNC CS-ID mode.*

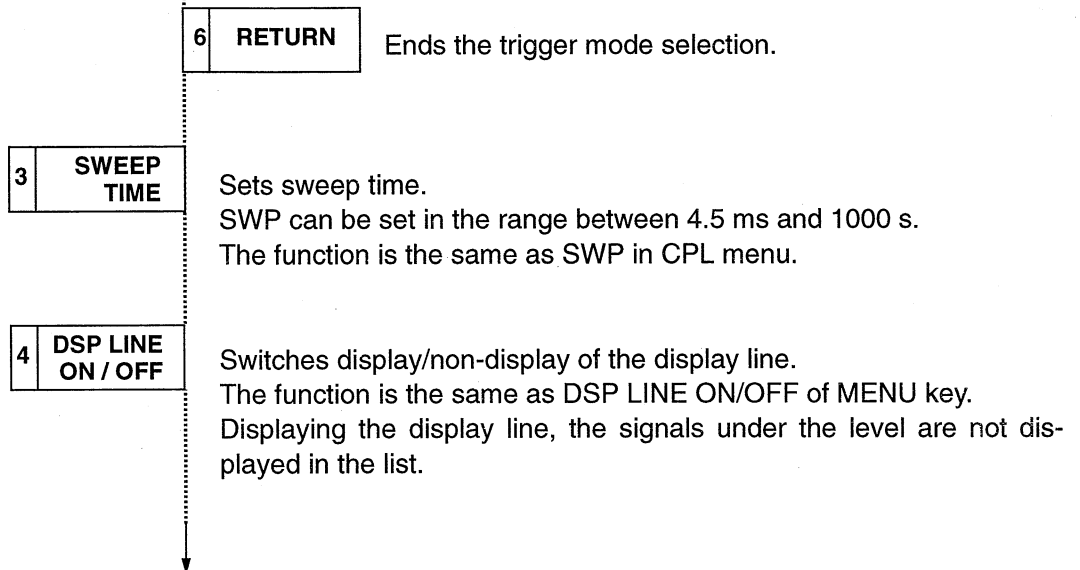

5 LIST SE UP

Sets measurement conditions and display conditions for trigger ID setting and ID list creation.

Method of SETUP operating

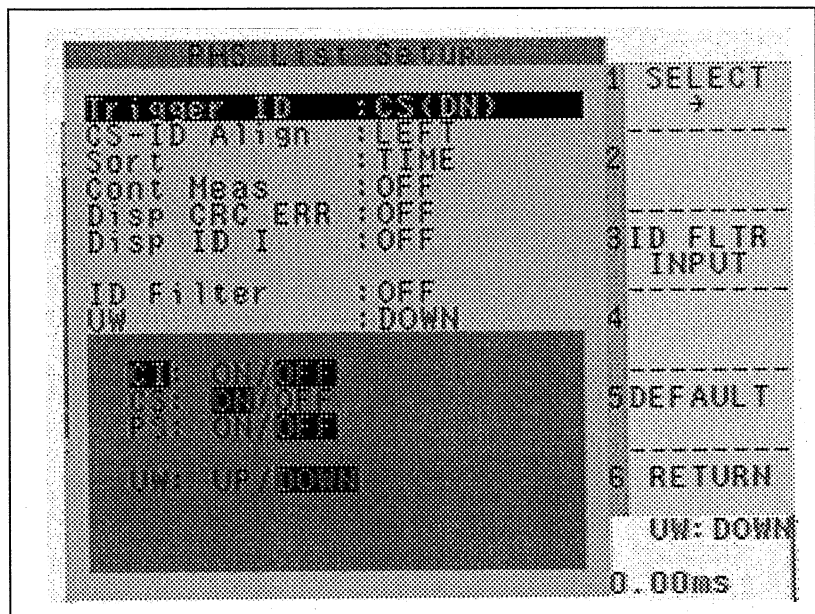
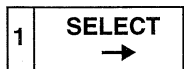

Figure 5-5 List setup menu

PHS List Setup

TRIGGER ID

Decides valid/invalid of the code set as a trigger condition. Combination of CI/CS-ID/PS-ID and up/down can be specified.



..... Selects ON/OFF and UP/DOWN.



..... Selects CI, CS, PS, or UW.

CAUTION!

When SYNC CS-ID is selected in trigger mode, this mode is set to down CS.

When SYNC CS-ID is released, the previous setting is restored.

PHS-ID DEMODULATION FUNCTION

5.2 Soft menu configuration

CS-ID Align

CS-ID code 42 bits is displayed with hexadecimal 11 digits.
Then, selects the display of left-aligned or right-aligned.



..... Selects LEFT/RIGHT.

Sort

Selects a way of ID list display order.
The selected items are time order and level order.
When outputting (GPIB/SAVE) to the outside, it is output with the condition sorted.



..... Selects TIME/LEVEL.

Cont Meas

Selects to perform the measurement contentiously with ID list displayed.
The selected items are ON/OFF.

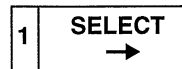

..... Selects ON/OFF.

Disp CRC ERR

When an error arises at CRC check, the code display becomes (----) for OFF setting.
For ON setting, the error code is displayed as it is.
In order to identify the code correct, "*" is added after PS-ID code.

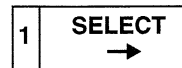

..... Selects ON/OFF.

Disp ID I

All the information of 62 bits after the control channel format CS-ID is displayed.

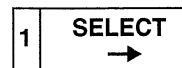

..... Selects ON/OFF.

ID Filter

Sets up the display conditions of measured ID code.
 Only IDs which match to the display conditions can be displayed.
 This mode has no relation to left-aligned or right-aligned.

Input method of ID filter

ID filter input is performed in bits. The display is also in bits.
 Regardless of "*", 1, and 0, it is displayed.
 When "1" or "0" is specified, the specified bit data, the bit patterns of measured codes, and the matching codes are displayed in the list.

Key assignment

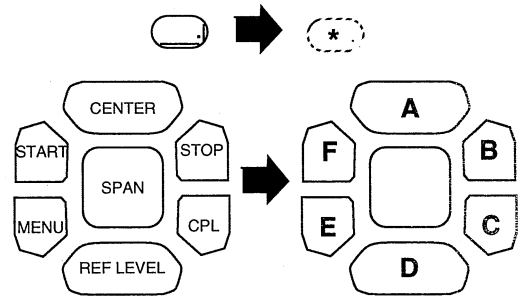

- * : (.)
- 0, 9 : 0, 9
- A : CENTER
- B : STOP
- C : CPL
- D : REF LEVEL
- E : MENU
- F : START



Input mode

BIN/HEX
 The cursor moves in bits to specify BIN with 1, 0, or (.) keys.
 The cursor moves in 4-bits to specify HEX with 0 to F, or (.) keys.

Key operation

-  Selects ON/OFF.
- By BIN/HEX setting, the cursor is moved horizontally in 1 or 4 bits.
-  The cursor is moved vertically.

UW

Selects UW up/down to be shown in ID list.

-  Selects UP, DOWN, or UP & DOWN.

PHS-ID DEMODULATION FUNCTION

5.2 Soft menu configuration

■ AUTO

Performs the measurement based on the set up measurement conditions and saves the results into memory card.

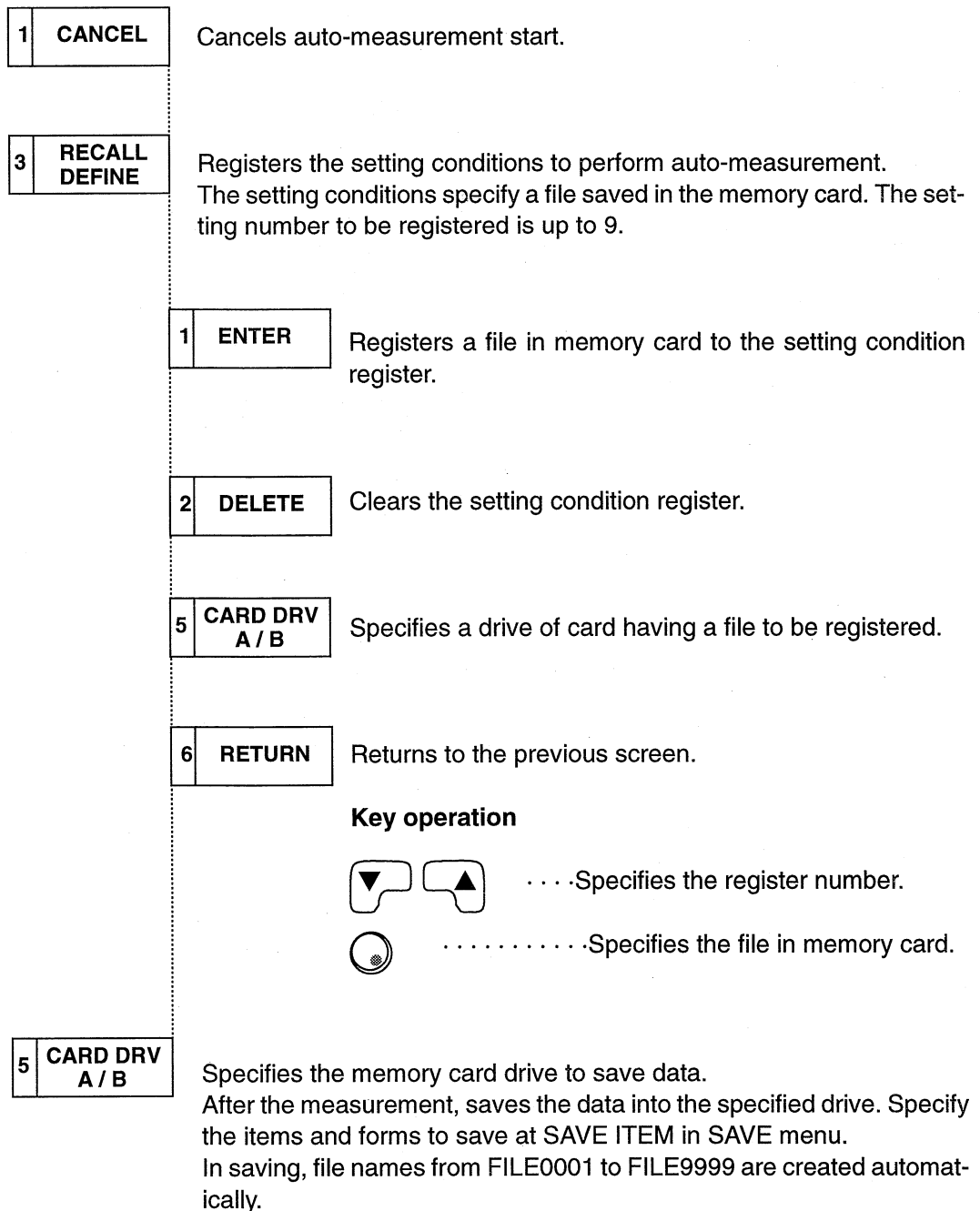

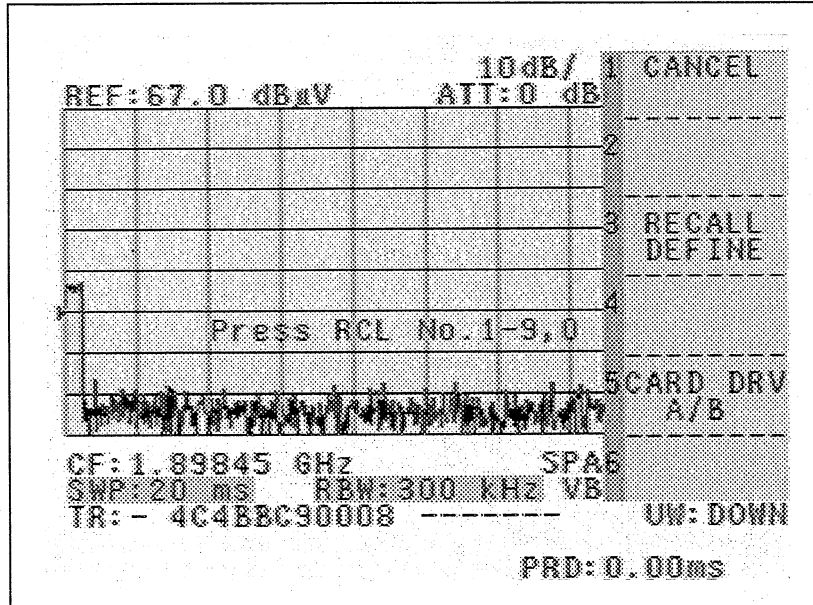

Pressing makes a state of waiting for RCL No. as the above figure.

Inputting the register number specified at

3	RECALL DEFINE
---	------------------

 with ten-key starts the measurement. After the completion, the measurement data is saved in the memory card. Pressing "0" key performs the measurement with the present setting.

The waveform data and ID list saved by can get a match even after recalled by RCL.

ID list creation
 ID list is created after 1 sweep. Therefore, pressing VIEW during sweep may not get a match between the waveform and the list.

PHS-ID DEMODULATION FUNCTION

5.2 Soft menu configuration

■ MEAS2 

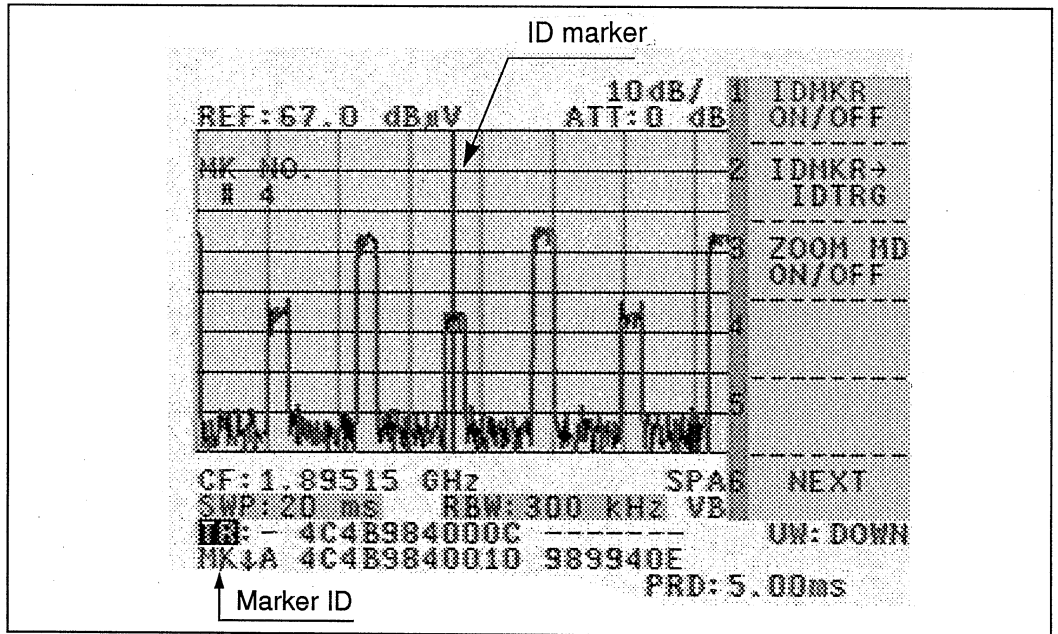





Figure 5-6 ID marker

1 ID MKR ON / OFF

* Displays ID code of the signal specified with ID marker (vertical cursor).
The marker number matches list display number.

ID marker is moved with   key and .
When the marker is displayed, moving ID marker moves the marker following to ID marker, and the signal and the level which are specified with ID marker can be seen.

2 IDMKR → IDTRG

Select ON with 1 IDMKR ON/OFF, then displays 2 IDMKR → IDTRG.

ID code of the signal specified with ID marker is set to trigger code.

3 ZOOM MD ON / OFF



* Minimizes (4.5 ms) the sweep time and enlarges the measurement signal.
When you want to change the sweep time, use MEAS1 DELAY SWEEP function.

*: When the sweep time is shorter than 4.5ms, ID MKR ON/OFF and ZOOM MD ON/OFF keys cannot be switched to ON.

4 ZOOM

Select ON with 3 ZOOM MD ON/OFF, then displays zoom position and

4 ZOOM

Zoom position is moved with   keys and . Enlarged with ZOOM. Pressing ZOOM again, the previous sweep time returns.

6 NEXT

The menu is changed to cumulative operation.

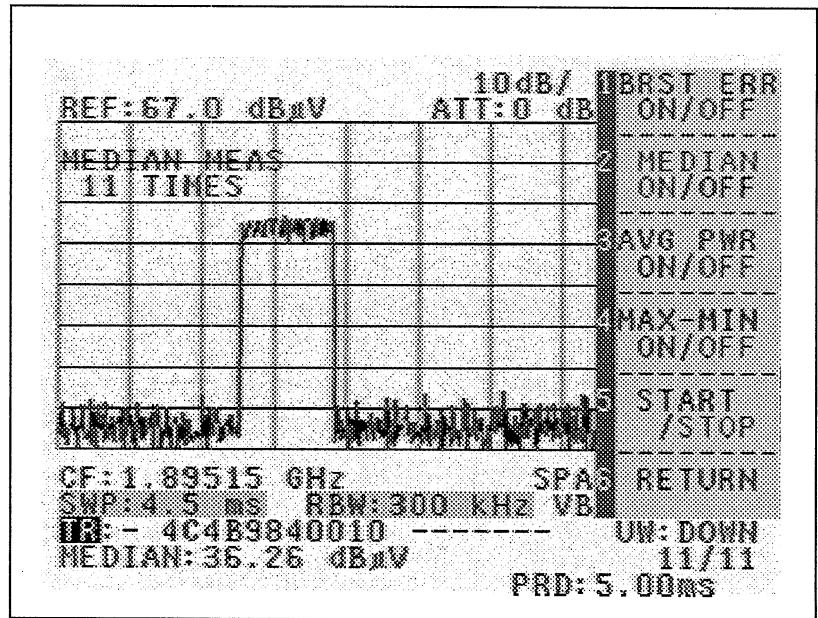

Figure 5-7 Cumulative operation menu

1 BRST ERR ON/OFF

Performs burst error rate measurement.

Burst error rate =
 Error slot number/measurement (setting) number
 Error slot number is the total number of the slot where UW is undetected and CRC check error arose.

2 MEDIAN ON/OFF

Processes median.

Median is the center measurement value in order of decreasing size.



PHS-ID DEMODULATION FUNCTION

5.2 Soft menu configuration

3	AVG PWR ON / OFF	Processes average value. <div style="border: 1px solid black; padding: 5px;">Average value : After converting measurement value (dBm, dBμV) to true value (W,V), divide the total by the number of measurement (setting) and convert the result to dB. This converted value is the average value.</div>
4	MAX-MIN ON / OFF	Processes maximum and minimum value. Find the maximum value and the minimum value from all the data obtained by measurement.
5	START / STOP	Starts/stops the above process.
6	RETURN	Returns to the previous menu screen. Measurements of BRST ER, MEDIAN, AVG PWR, and MAX-MIN are performed to CS-ID (DOWN) which is set to trigger. Trigger mode is switched to SYNC CS-ID automatically.

Start of setting the number of measurement and measuring

Setting each measurement to ON starts measurement with the setting value which has already been set.

The setting value is changed with ten-key and  (1 step), and   key.

After the setting, start measurement.

Press START/STOP to stop the measurement in the middle.

Pressing START/STOP in the stop state starts again.

Maximum setting value

BRST ERR :	999
MEDIAN :	300
AVG PWR :	300
MAX-MIN :	300

■ CENTER

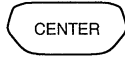

Center frequency can be set with frequency and channel (carrier).

4	UNIT Hz / CH
---	-----------------

Switches input unit to Hz and CH.

5	PHS CH LIST
---	----------------

Displays 1 to 77CH frequency assignment table.

6	AUTO SCAN
---	--------------

Scans signal in order of channel.
When demodulation signal is found, it stops at the channel.
Pressing AUTO SCAN again restarts the measurement.

Setting for measurement

RBW 300kHz

SWP 400ms

TRIGGER FREE RUN

(Switch to HI-SENS mode if necessary.)

Measurement start channel

It depends on center frequency input mode Hz/CH.

Hz Starts from 1 ch.

CH Starts from present setting channel + 1 ch.

When signal is detected, it stops at the channel.

6. GPIB

This chapter provides a description of GPIB code lists and examples of program, etc.

6.1 GPIB code list

Note: *The following codes are about PHS-ID demodulation functions. For other codes, see "List of GPIB Codes" in the operation manual.*

- U3641 Series Operation Manual
- U4941/4341/4342 Series Operation Manual

Refer to the manual which you are using.

[Notes for the table]

- * in the listener code column shows the function which can input numeric data following to code.
- + in the output format column shows that it can output plural data.
- Each AUTO/MANUAL in output format column outputs I/O.
- Each ON/OFF in output format column outputs I/O.
- ☆ in the remarks column shows the initial value set after power-on.
- – shows unsuitable.
- In the output format column, unit of frequency and time are used in Hertz (Hz) and second, respectively.

PHS-ID DEMODULATION FUNCTION

6.1 GPIB code list

Function	Listener code	Talker request			Remarks
		Code	Output format	Header	
PHS ON OFF TRIGGER	PHS ON PHS OFF	PHS? TRMD?	ON/OFF 0: FREE RUN 2: VIDEO 7: ID 8: SYNC CS-ID		
FREE RUN VIDEO ID SYNC CS-ID & DELAY SWEEP TIME DISP LINE ID LIST ID TRIGGER	FREE PHS VIDEO PHS* ID SYCDLY* SWP PHS* DL PHS*	SYCDLY? IDLIST? IDTRCI? IDTRCS? IDTRPS?	Refer to Fig. 6-1. String String String	SYD	
ID LIST PHS CHANNEL	PHSCH*	IDLIST? PHSCH? CHUNIT?	Integer 0: Hz 1: CH	PCH	
UNIT Hz UNIT CH AUTO SCAN	CHUNFR CHUNCH ATSCAN				

Function	Listener code	Talker request			Remarks
		Code	Output format	Header	
ID LIST SETUP					
TRIGGER ID		TRID?	0: CS 1: PS 2: CS&PS 3: CI&CS 4: CI&PS 5: CI&CS&PS		
CS PS CS&PS CI&CS CI&PS CI&CS&PS UW	TICS TIPS TICSPS TICICS TICIPS TICCP	TRIDUW?	0: UP 1: DOWN		
Align	TIUP TIDN	IDALIGN?	0: LEFT 1: RIGHT		
Sort	IDLEFT IDRIGHT	IDSORT?	0: TIME 1: LEVEL		
Disp CRC ERR	IDTIME IDLVL	IDCRC?	ON/OFF		
Disp I	IDCRC ON IDCRC OFF	IDI?			
ID Filter	IDI ON IDI OFF	IDFLTR?	ON/OFF		
	IDFLTR ON IDFLTR OFF	IDFLCI? IDFLCS? IDFLPS? IDFLBIN IDFLHEX IDUW?	String String String		
UW			0: UP 1: DOWN 2: UP&DOWN		
ID LIST SETUP DEFAULT	IDUP IDDN IDUPDN IDLTDFT				

PHS-ID DEMODULATION FUNCTION

6.1 GPIB code list

Function	Listener code	Talker request			Remarks
		Code	Output format	Header	
MEAS2					
ID Marker ON OFF	IDMK* IDMK ON IDMK OFF	IDMK?	Refer to Fig. 6-2.		
ID Mkr → ID Trig	IDMTOTR				
Zoom Mode ON OFF	ZMMD ZMMD ON ZMMD OFF	ZMMD?	ON/OFF		
Zoom Position	ZMPOS*	ZMPOS?	Time	ZMP	
Zoom	ZOOM ON ZOOM OFF	ZOOM?	ON/OFF		
MAX-MIN ON OFF	MAXMS ON MAXMS OFF	MAXMS?	ON/OFF		
AVG PWR ON OFF	APMS ON APMS OFF	MAXMIN? APMS?	Level + Level ON/OFF	MM	
Median ON OFF	MEDMS ON MEDMS OFF	AVGPWR? MEDMS?	Level ON/OFF	APW	
Burst Error ON OFF	BSTMS ON BSTMS OFF	MEDIAN? BSTMS?	Level ON/OFF	MED	
Measurement number of times	IDMS*	BSTERR?	Refer to Fig. 6-3.	BST	
Measurement start	MSST	IDMS?		MS	
Measurement stop	MSSP				
CS-DOWN cycle		PRD?	Time	PRD	

6.2 Output format

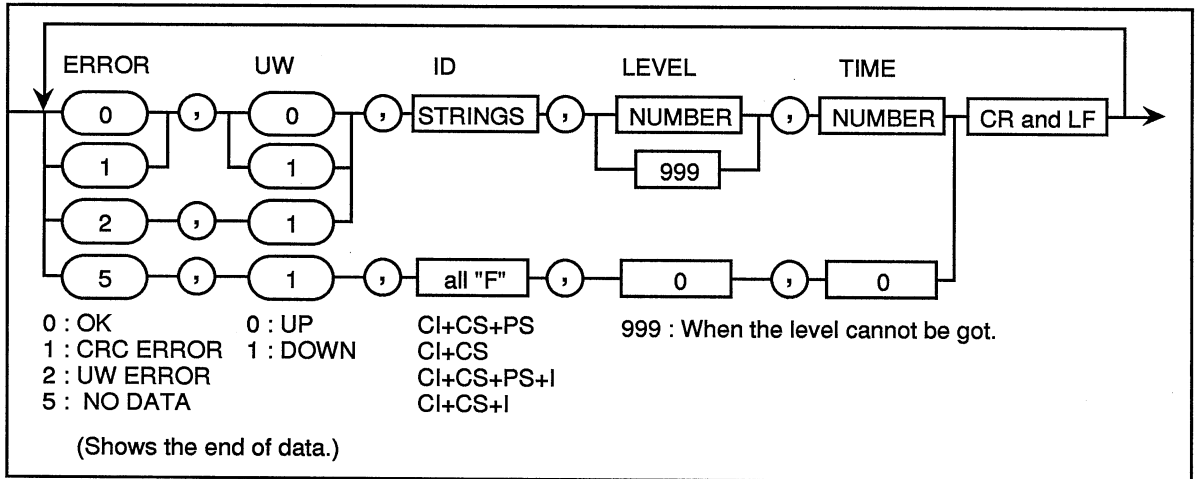

Figure 6-1 Output format of ID list

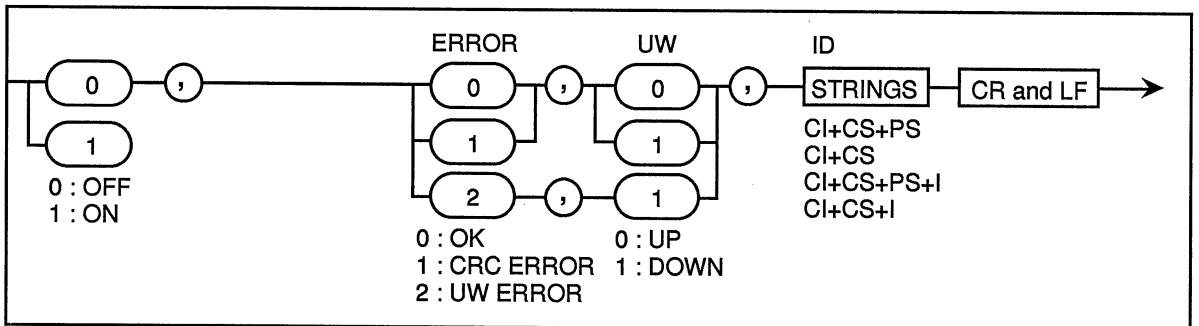

Figure 6-2 Output format of ID marker

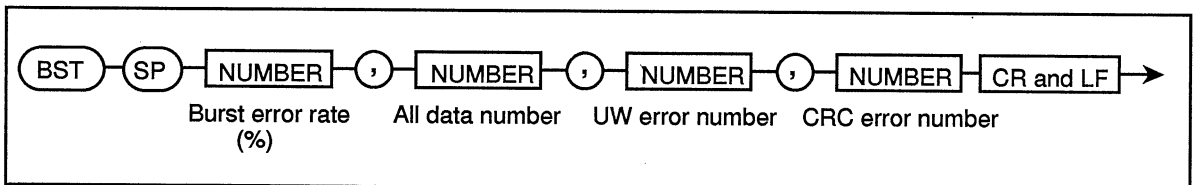

Figure 6-3 Output format of burst error measurement result

6.3 Status list

Bit	Decimal system	Contents
0	1	When UNCAL is generated, 1 comes up.
1	2	When calibration ends, 1 comes up.
2	4	When sweep ends, 1 comes up.
3	8	When average comes to the set number of times, 1 comes up.
4	16	When plot output ends, 1 comes up.
5	32	When error arises in message code of this function, 1 comes up.
6	64	Undefined.
7	128	Undefined.

The following contents are added to the third bit of normal status byte.

Auto scan: When scan function ends, 1 comes up.
(Signal may not be found.)

Burst error measurement: When the measurement completes up to the set number of times, 1 comes up.

Measurement of median: When the measurement completes up to the set number of times, 1 comes up.

Measurement of average power:
When the measurement completes up to the set number of times, 1 comes up.

Measurement of Maximum and minimum values:

When the measurement completes up to the set number of times, 1 comes up.

6.4 Examples of program

N-88BASIC of PC9801 series produced by Nihon Denki is used for the following examples of program.

● Setting example of ID trigger

```

10 ISET IFC: ISET REN
20 PRINT @8;"TICCP"           Set trigger ID to CI/CS/PS.
30 PRINT @8;"IDTRCI/5/"      Set CI trigger.
40 PRINT @8;"IDTRCS/123456789AB/" Set CS trigger.
50 PRINT @8;"IDTRPS/1234567/" Set PS trigger.
60 PRINT 28;"ID"            Set trigger mode to ID.
70 END

```

● Examples to read ID trigger

```

10 ISET IFC: ISET REN
20 PRINT @8;"IDTRCI?"        Read CI trigger.
30 INPUT @8;CI$
40 PRINT @8;"IDTRCS?"        Read CS trigger.
50 INPUT @8;CS$
60 PRINT @8;"IDTRPS?"        Read PS trigger.
70 INPUT @8;PS$
80 END

```

● Setting example of ID filter

Only the IDs that CI is 5 are listed. (Any ID is listed for CS/PS.)

```

10 ISET IFC: ISET REN
20 PRINT @8;"IDFLHEX"        Make input mode of ID filter to
                               hexadecimal number.
30 PRINT @8;"IDFLCI/5/"      Set CI filter.
40 PRINT @8;"IDFLCS/*****/" Set CS filter.
50 PRINT @8;"IDFLPS/*****/" Set PS filter.
60 PRINT @8;"IDFLTR ON"      Set ID filter to ON.
70 END

```

PHS-ID DEMODULATION FUNCTION

6.4 Examples of program

● To perform auto-scan function

```
10 ISET IFC: ISET REN
20 PRINT @8;"S2"           Clear status byte.
30 PRINT @8;"ATSCAN"      Start auto-scan.
40 *LOOP
50 POLL 8, S              Read status byte into variable s.
60 IF (S AND 8)=0 THEN GOTO *LOOP  Loop till 1 comes up at the third bit.
70 END
```

● To perform burst error measurement (Refer to Fig. 6-3 for the output format.)

```
10 ISET IFC: ISET REN
20 PRINT @8;"HD0"         Header OFF.
30 PRINT @8;"S2"         Clear status byte.
40 PRINT @8;"BSTMS ON"   Set measurement mode of burst error to ON.
50 PRINT @8;"IDMS 20ENT" Set measurement number of times to 20.
60 *LOOP
70 POLL 8, S             Read status byte into variable s.
80 IF (S AND 8)=0 THEN GOTO *LOOP  Loop till 1 comes up at the third bit.
90 PRINT @8;"BSTERR?"    Read measurement result.
100 INPUT @8;PER,CNT,UW,CRC
110 END
```

● To perform measurement of median

```
10 ISET IFC: ISET REN
20 PRINT @8;"HD0"         Header OFF.
30 PRINT @8;"S2"         Clear status byte.
40 PRINT @8;"MEDMS ON"   Set measurement mode of burst error to ON.
50 PRINT @8;"IDMS 20ENT" Set measurement number of times to 20.
60 *LOOP
70 POLL 8, S             Read status byte into variable s.
80 IF (S AND 8)=0 THEN GOTO *LOOP  Loop till 1 comes up at the third bit.
90 PRINT @8;"MEDIAN?"    Read measurement result.
100 INPUT @8;MED
110 END
```

● To perform measurement of average power

```

10 ISET IFC: ISET REN
20 PRINT @8;"HD0"           Header OFF.
30 PRINT @8;"S2"           Clear status byte.
40 PRINT @8;"APMS ON"      Set measurement mode of burst error to ON.
50 PRINT @8;"IDMS 20ENT"   Set measurement number of times to 20.
60 *LOOP
70 POLL 8, S               Read status byte into variable s.
80 IF (S AND 8)=0 THEN GOTO *LOOP Loop till 1 comes up at the third bit.
90 PRINT @8;"AVGPWR?"      Read measurement result.
100 INPUT @8;PWR
110 END

```

● To perform measurement of maximum/minimum values

```

10 ISET IFC: ISET REN
20 PRINT @8;"HD0"           Header OFF.
30 PRINT @8;"S2"           Clear status byte.
40 PRINT @8;"MAXMS ON"     Set measurement mode of burst error to ON.
50 PRINT @8;"IDMS 20ENT"   Set measurement number of times to 20.
60 *LOOP
70 POLL 8, S               Read status byte into variable s.
80 IF (S AND 8)=0 THEN GOTO *LOOP Loop till 1 comes up at the third bit.
90 PRINT @8;"MAXMIN?"      Read measurement result.
100 INPUT @8;MAX,MIN
110 END

```

● To read ID of ID marker (Refer to Fig. 6-2 for the output format.)

```

10 ISET IFC: ISET REN
20 PRINT @8;"IDMK 5ENT"     Move ID marker to the fifth ID waveform.
30 PRINT @8;"IDMK?"        Read ID of ID marker.
40 PRINT @8;ONOFF,ER,IP,ID$
50 END

```

● To read ID list (Refer to Fig. 6-11 for the output format.)

```

10 ISET IFC: ISET REN
20 PRINT @8;"S2"           Clear status byte.
30 *LOOP
40 POLL 8, S
50 IF (S AND 4)=0 THEN GOTO *LOOP Loop till 1 comes up at the second bit.
60 PRINT @8;"IDLIST?"      Read ID list.
70 *READID
80 INPUT @8;ER,UP,ID$,LEVEL,TIM Read ID data for 1 slot.
90 IF ER<>5 THEN GOTO *READID When ER becomes to 5, the data ends.
100 END

```

7. Specifications of performance

This chapter provides a description of specifications of PHS-ID demodulation function performance.

Note: *The following specifications of performance are about PHS-ID demodulation functions. For other specifications of performance, see "Specifications of performance" in the operation manual.*

- U3641 Series Operation Manual
 - U4941/4341/4342 Series Operation Manual
- Refer to the manual which you are using.**

● Incoming signal

PHS logic control channel (Except option)

* Based on RCR STD-28.

● Level measurement

Pre-amp = ON (ATT = 0dB)	+16dB μ V to +67dB μ V (-91dBm to -40dBm)
Pre-amp = OFF (ATT = 10dB)	+52dB μ V to +107db μ V (-55dBm to -0dBm)

* Sweep time is under 400 ms.

● Level operating function

Median process, average process, maximum/minimum process

● Trigger mode

Free Run, Video, ID, Sync CS-ID

● Measurement items

- Base station/mobile station level measurement
- Specified base station burst error rate measurement
- Specified base station cycle measurement

● Function

- Frequency channel set
- Measurement result list display
(CS-ID, PS-ID, CI, I, level, and time)
- ID marker
- Auto-measurement (Saves measurement results into memory card.)

PHS-ID DEMODULATION FUNCTION

7. Specifications of performance

- Recommended operation environment
10°C to 40°C

APPENDIX

This chapter provides a description of PHS carrier frequency assignment, memory card CSV type, software menu list and display message list.

A.1 PHS carrier frequency assignment

Carrier No.	Frequency (MHz)	Carrier No.	Frequency (MHz)
1	1895.15	38	1906.25
2	1895.45	39	1906.55
3	1895.75	40	1906.85
4	1896.05	41	1907.15
5	1896.35	42	1907.45
6	1896.65	43	1907.75
7	1896.95	44	1908.05
8	1897.25	45	1908.35
9	1897.55	46	1908.65
10	1897.85	47	1908.95
11	1898.15	48	1909.25
12	1898.45	49	1909.55
13	1898.75	50	1909.85
14	1899.05	51	1910.15
15	1899.35	52	1910.45
16	1899.65	53	1910.75
17	1899.95	54	1911.05
18	1900.25	55	1911.35
19	1900.55	56	1911.65
20	1900.85	57	1911.95
21	1901.15	58	1912.25
22	1901.45	59	1912.55
23	1901.75	60	1912.85
24	1902.05	61	1913.15
25	1902.35	62	1913.45
26	1902.65	63	1913.75
27	1902.95	64	1914.05
28	1903.25	65	1914.35
29	1903.55	66	1914.65
30	1903.85	67	1914.95
31	1904.15	68	1915.25
32	1904.45	69	1915.55
33	1904.75	70	1915.85
34	1905.05	71	1916.15
35	1905.35	72	1916.45
36	1905.65	73	1916.75
37	1905.95	74	1917.05
		75	1917.35
		76	1917.65
		77	1917.95

PHS-ID DEMODULATION FUNCTION

A.2 Memory card CSV type

A.2 Memory card CSV type

- Binary type and CSV type

	Binary type	CSV type
Necessary memory size (Trace 1 screen)	Small 1.4kbyte	Large 2.8kbyte (max)
Processing speed	Fast	Slow

- Examples of process by personal computer

An example of measurement data process by spreadsheet software (Microsoft Excel) of Microsoft Co. is shown here.

The figure shows the file opened.

- A and B columns: Trace data
- C, D, and E columns: Setting data
- F, G, H, and I columns: Limit line data
- J, K, L, M, N, O, P, and Q columns: ID list

A	B	C	D	E
TRACE A	TRACE B			
2602	1724	LABEL		
2323	1057	CF	1.9	GHz
2604	1731	SP	0	kHz
2326	964	FO		
2598	1713	REB	-40	dBm
932	980	RO		
1678	1732	DIV	10	dB/
1038	1018	AT	0	dB
1718	1711	HS ON		
1076	1053	RB	3	MHz
1698	1739	VB	3	MHz
1044	1004	SW	50	ms
1732	1699			

F	G	H	I
L1-TIME(sec)	L1-LEVEL(dBm)	L2-TIME(sec)	L2-LEVEL(dBm)
0.001	0.1	0.05	5
0.002	0.2	0.051	5.1
0.003	0.3	0.052	5.2
0.004	0.4	0.053	5.3
0.005	0.5	0.054	5.4
0.006	0.6	0.055	5.5
0.007	0.7	0.056	5.6
0.008	0.8	0.057	5.7
0.009	0.9	0.058	5.8
0.01	1	0.059	5.9
0.011	1.1	0.06	6
0.012	1.2	0.061	6.1
0.013	1.3	0.062	6.2

J	K	L	M	N	O	P	Q
ERROR	UP(0)/DOWN(1)	CI	CS	PS	I	LEVEL(dBm)	TIME(ms)
0	1	A	48D159E26AC	1234567		-94.59	0
0	1	A	48D159E26AC	1234567		-94.22	5
0	1	A	48D159E26AC	1234567		-94.52	10
0	1	A	48D159E26AC	1234567		-94.91	15
0	1	A	48D159E26AC	1234567		-95.4	20
0	1	A	48D159E26AC	1234567		-93.16	25
0	1	A	48D159E26AC	1234567		-92.79	30
0	1	A	48D159E26AC	1234567		-94.77	35
0	1	A	48D159E26AC	1234567		-94.66	40
0	1	A	48D159E26AC	1234567		-94.3	45

- ① Trace data is saved with internal data form. Data value "2720" is REF LEVEL. Expression of conversion from trace data to dB value is as follows.

$$\text{Level(dB)} = \text{REF} - 10 * \text{DIV} * (1 - \text{DATA} / 2720)$$

REF: REF LEVEL set value

DIV: dB/ set value

DATA: Trace data set value

Trace data enters in from the second line to 702nd line. The data in the second line corresponds to school left end and the 702nd line to right end.

- ② The set code is specified by GPIB code(Listener code or Header).

CF → Center frequency

REB → Reference level (Unit: dBm)

- ③ Error code of ID list (J column)

0: No error

1: CRC error

2: UW error

PHS-ID DEMODULATION FUNCTION

A.2 Memory card CSV type

Graph by data saved

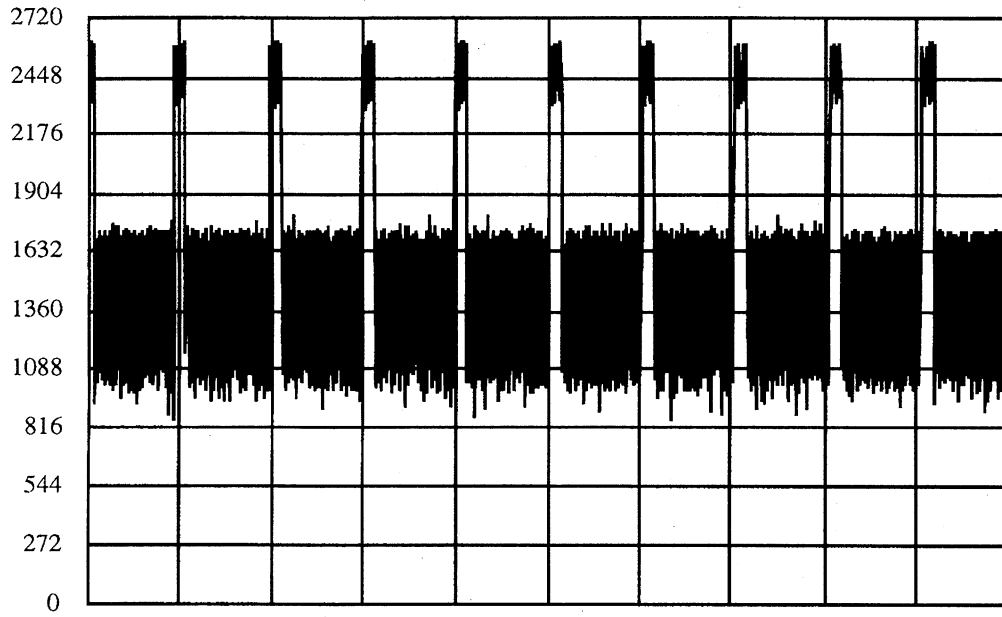

Graph by vertical axis dB value conversion

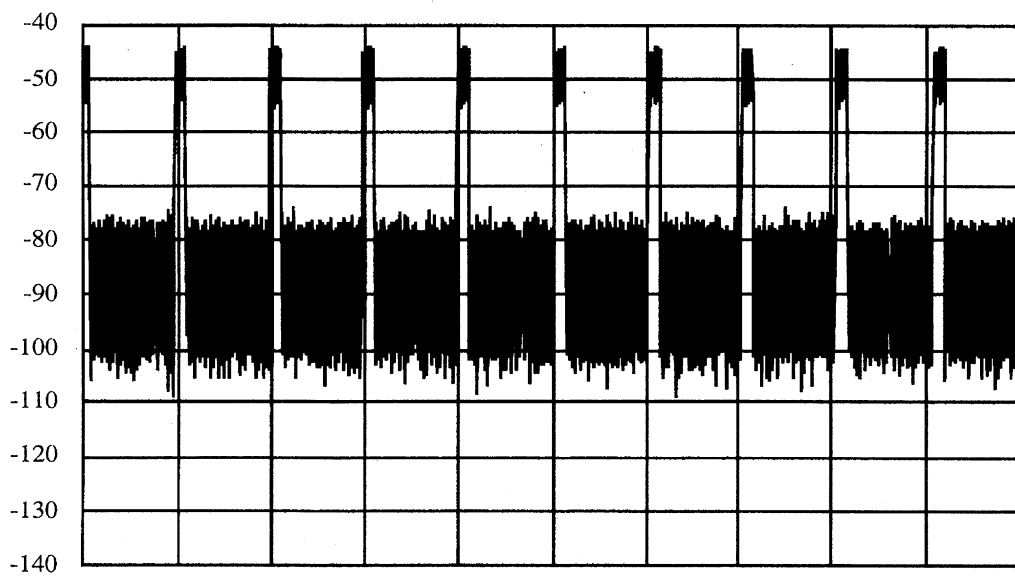

A.3 Soft menu list

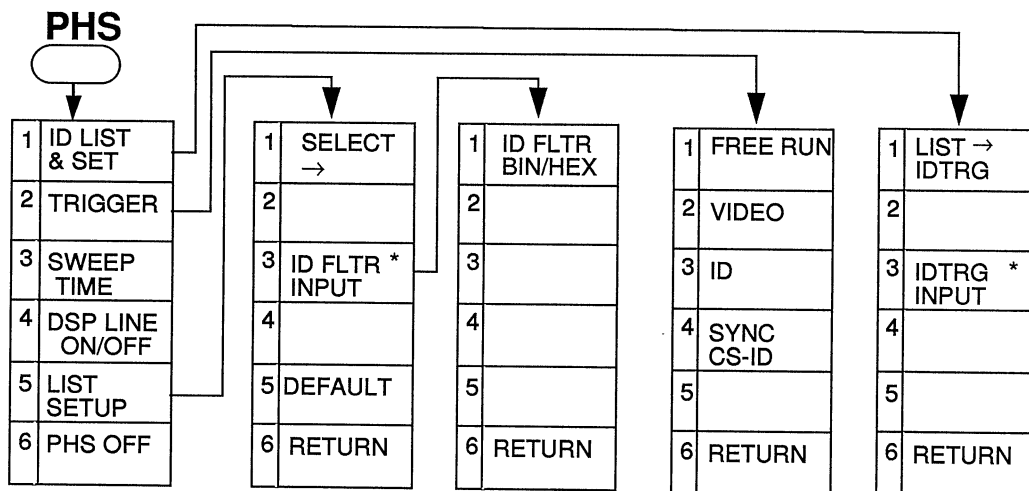

* : The operation with normal key cannot be performed.

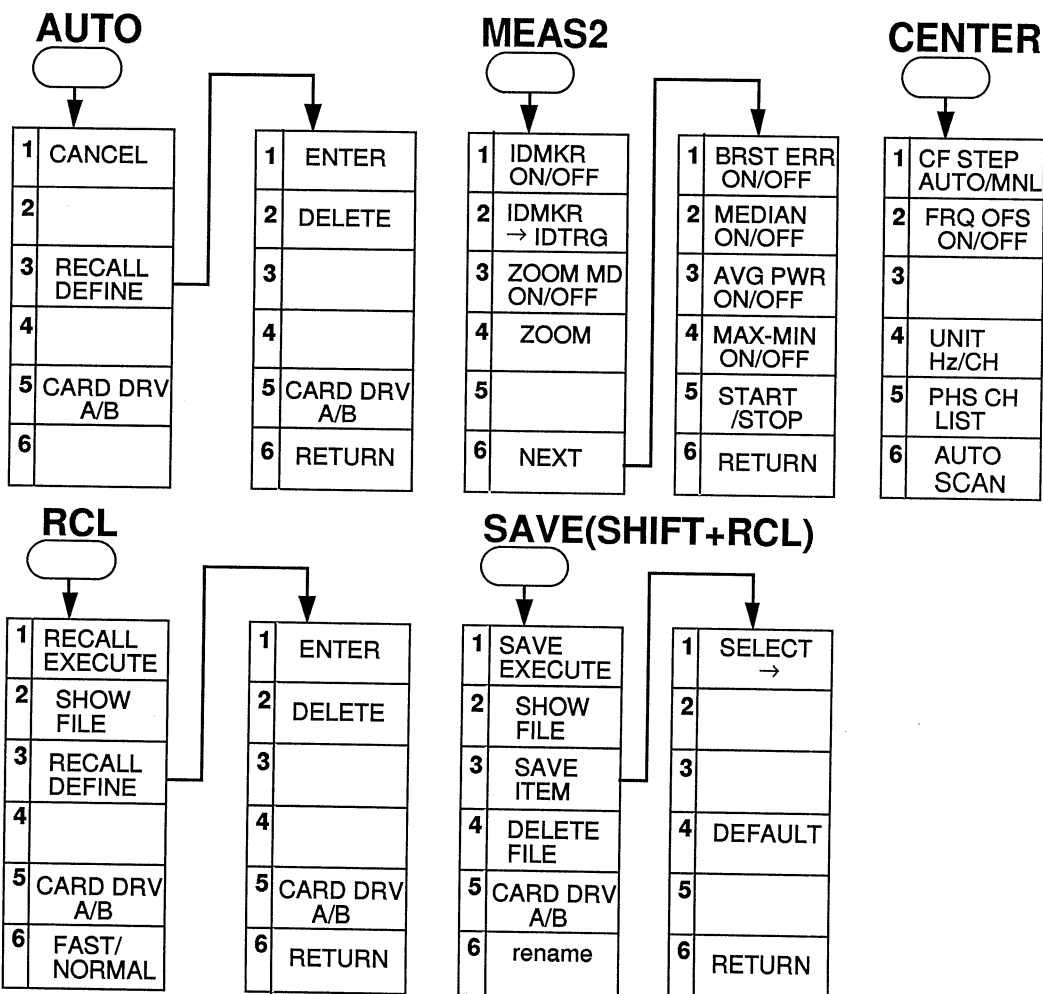

PHS-ID DEMODULATION FUNCTION

A.4 Display message list

A.4 Display message list

Error code	Display message	Contents
ERR227	NG LIN SCL	As linear scale is set, PHS mode cannot be set.
ERR315	NG MNL SWP	As MANUAL SWEEP mode is set, PHS mode cannot be set.
ERR369	LMT LINE ON	As limit line is displayed, PHS mode cannot be set.
ERR700	NG PHS MD	As PHS mode is set, linear scale cannot be set.
ERR701	NG PHS MD	As PHS mode is set, MANUAL SWEEP cannot be set.
ERR702	NG PHS MD	As PHS mode is set, limit line cannot be displayed.
ERR703	NG PHS MD	As PHS mode is set, measurement window cannot be displayed.
ERR705	SYNC CS-ID	As SYNC CS-ID trigger is set, delay sweep mode with limit line displayed cannot be set.
ERR706	SYNC CS-ID	As SYNC CS-ID trigger is set, zoom mode cannot be set.
ERR707	NG SYNC	As ID cycle is not measured, SYNC CS-ID trigger cannot be set.
ERR708	NG SYNC	As ID cycle is not measured, operation process cannot be started.
ERR709	ID MEAS ON	As operation process is set, trigger cannot be changed.
ERR710	ID MEAS ON	As operation process is set, sweep time cannot be changed.
ERR711	NOT FOUND	Signal cannot be found by AUTO SCAN.
ERR712	NG ID MKR	As operation process is set, ID marker cannot be set.

LIMITED WARRANTY

1. Unless otherwise specifically agreed by Seller and Purchaser in writing, ADVANTEST will warrant to the Purchaser that during the Warranty Period this Product (other than consumables included in the Product) will be free from defects in material and workmanship and shall conform to the specifications set forth in this Operation Manual.
2. The warranty period for the Product (the "Warranty Period") will be a period of one year commencing on the delivery date of the Product.
3. If the Product is found to be defective during the Warranty Period, ADVANTEST will, at its option and in its sole and absolute discretion, either (a) repair the defective Product or part or component thereof or (b) replace the defective Product or part or component thereof, in either case at ADVANTEST's sole cost and expense.
4. This limited warranty will not apply to defects or damage to the Product or any part or component thereof resulting from any of the following:
 - (a) any modifications, maintenance or repairs other than modifications, maintenance or repairs (i) performed by ADVANTEST or (ii) specifically recommended or authorized by ADVANTEST and performed in accordance with ADVANTEST's instructions;
 - (b) any improper or inadequate handling, carriage or storage of the Product by the Purchaser or any third party (other than ADVANTEST or its agents);
 - (c) use of the Product under operating conditions or environments different than those specified in the Operation Manual or recommended by ADVANTEST, including, without limitation, (i) instances where the Product has been subjected to physical stress or electrical voltage exceeding the permissible range and (ii) instances where the corrosion of electrical circuits or other deterioration was accelerated by exposure to corrosive gases or dusty environments;
 - (d) use of the Product in connection with software, interfaces, products or parts other than software, interfaces, products or parts supplied or recommended by ADVANTEST;
 - (e) the occurrence of an event of force majeure, including, without limitation, fire, explosion, geological change, storm, flood, earthquake, tidal wave, lightning or act of war; or
 - (f) any negligent act or omission of the Purchaser or any third party other than ADVANTEST.
5. **EXCEPT TO THE EXTENT EXPRESSLY PROVIDED HEREIN, ADVANTEST HEREBY EXPRESSLY DISCLAIMS, AND THE PURCHASER HEREBY WAIVES, ALL WARRANTIES, WHETHER EXPRESS OR IMPLIED, STATUTORY OR OTHERWISE, INCLUDING, WITHOUT LIMITATION, (A) ANY WARRANTY OF MERCHANTABILITY OR FITNESS FOR A PARTICULAR PURPOSE AND (B) ANY WARRANTY OR REPRESENTATION AS TO THE VALIDITY, SCOPE, EFFECTIVENESS OR USEFULNESS OF ANY TECHNOLOGY OR ANY INVENTION.**
6. **THE REMEDY SET FORTH HEREIN SHALL BE THE SOLE AND EXCLUSIVE REMEDY OF THE PURCHASER FOR BREACH OF WARRANTY WITH RESPECT TO THE PRODUCT.**
7. **ADVANTEST WILL NOT HAVE ANY LIABILITY TO THE PURCHASER FOR ANY INDIRECT, INCIDENTAL, SPECIAL, CONSEQUENTIAL OR PUNITIVE DAMAGES, INCLUDING, WITHOUT LIMITATION, LOSS OF ANTICIPATED PROFITS OR REVENUES, IN ANY AND ALL CIRCUMSTANCES, EVEN IF ADVANTEST HAS BEEN ADVISED OF THE POSSIBILITY OF SUCH DAMAGES AND WHETHER ARISING OUT OF BREACH OF CONTRACT, WARRANTY, TORT (INCLUDING, WITHOUT LIMITATION, NEGLIGENCE), STRICT LIABILITY, INDEMNITY, CONTRIBUTION OR OTHERWISE.**

CUSTOMER SERVICE DESCRIPTION

In order to maintain safe and trouble-free operation of the Product and to prevent the incurrence of unnecessary costs and expenses, ADVANTEST recommends a regular preventive maintenance program under its maintenance agreement.

ADVANTEST's maintenance agreement provides the Purchaser on-site and off-site maintenance, parts, maintenance machinery, regular inspections, and telephone support and will last a maximum of ten years from the date the delivery of the Product. For specific details of the services provided under the maintenance agreement, please contact the nearest ADVANTEST office or ADVANTEST's sales representatives.

Some of the components and parts of this Product have a limited operating life (such as, electrical and mechanical parts, fan motors, unit power supply, etc.). Accordingly, these components and parts will have to be replaced on a periodic basis. If the operating life of a component or part has expired and such component or part has not been replaced, there is a possibility that the Product will not perform properly. Additionally, if the operating life of a component or part has expired and continued use of such component or part damages the Product, the Product may not be repairable. Please contact the nearest ADVANTEST office or ADVANTEST's sales representatives to determine the operating life of a specific component or part, as the operating life may vary depending on various factors such as operating condition and usage environment.

CLAIM FOR DAMAGE IN SHIPMENT TO ORIGINAL BUYER

The product should be thoroughly inspected immediately upon original delivery to buyer. All material in the container should be checked against the enclosed packing list or the instruction manual alternatively. ADVANTEST will not be responsible for shortage unless notified immediately.

If the product is damaged in any way, a claim should be filed by the buyer with carrier immediately. (To obtain a quotation to repair shipment damage, contact ADVANTEST or the local supplier.) Final claim and negotiations with the carrier must be completed by buyer.

