

**SERIES 6000B  
AC LINE CONDITIONER**



## WARRANTY

Elgar Corporation warrants each instrument it manufactures to be free from defects in material and workmanship. The corporation's obligation under this warranty is limited to servicing the instrument and replacing defective parts. This warranty is effective for one year after delivery of the instrument to the original purchaser. Defects caused by improper operating conditions, misuse, negligence, or the alteration or removal of the nameplate, will void the warranty. Elgar Corporation shall in no circumstance be liable for any direct or consequential loss or damage of any nature resulting from the malfunction of the instrument. This warranty is effective in lieu of any or all other obligations or liabilities on the part of Elgar Corporation, its agents, or representatives.

**DO NOT RETURN THE UNIT FOR REPAIR WITHOUT AUTHORIZATION FROM ELGAR CORPORATION.** Unauthorized returns found to be within specifications will result in a \$50.00 inspection fee, plus two-way freight charges.

Unless specifically noted in the Purchase Order or Maintenance Agreement, Elgar's warranty is F.O.B. the Elgar Service Center nearest the installation site, and serviceman's travel and expenses or transportation costs will be billed to the customer at cost.



**ELGAR CORPORATION . . . THE BEST SOURCE OF POWER**  
9250 Brown Deer Road, San Diego, California 92121  
Phone 619-450-0085

1  
2  
3  
4  
5  
6  
7  
8  
9  
10  
11  
12  
13  
14  
15  
16  
17  
18  
19  
20  
21  
22  
23  
24  
25  
26  
27  
28  
29  
30  
31  
32  
33  
34  
35  
36  
37  
38  
39  
40  
41  
42  
43  
44  
45  
46  
47  
48  
49  
50  
51  
52  
53  
54  
55  
56  
57  
58  
59  
60  
61  
62  
63  
64  
65  
66  
67  
68  
69  
70  
71  
72  
73  
74  
75  
76  
77  
78  
79  
80  
81  
82  
83  
84  
85  
86  
87  
88  
89  
90  
91  
92  
93  
94  
95  
96  
97  
98  
99  
100

## TABLE OF CONTENTS

### SECTION I

#### INTRODUCTION AND GENERAL DESCRIPTION

INTRODUCTION . . . . .	1-1
SCOPE OF MANUAL . . . . .	1-1
GENERAL DESCRIPTION . . . . .	1-1

### SECTION II

#### SPECIFICATIONS

SPECIFICATIONS . . . . .	2-1
--------------------------	-----

### SECTION III

#### PRELIMINARY INSPECTION AND OPERATION

OPERATION . . . . .	3-1
---------------------	-----

### SECTION IV

#### ADJUSTMENT AND SPECIFICATION VALIDATION

OUTPUT VOLTAGE AND REFERENCE PHASE ADJUSTMENT . . . . .	4-1
OUTPUT VOLTAGE ADJUSTMENT . . . . .	4-1
REFERENCE VOLTAGE PHASE ADJUSTMENT . . . . .	4-1
SPECIFICATION VALIDATION . . . . .	4-1
REGULATION SPECIFICATIONS . . . . .	4-2
HARMONIC DISTORTION . . . . .	4-2
RESPONSE TIME . . . . .	4-2
INPUT FREQUENCY RANGE . . . . .	4-2
NORMAL MODE REJECTION . . . . .	4-2

### SECTION V

#### THEORY OF OPERATION

BLOCK DIAGRAM DESCRIPTION . . . . .	5-1
CIRCUIT DESCRIPTION . . . . .	5-1
POWER INPUT CIRCUIT . . . . .	5-1
POWER TRANSFORMER . . . . .	5-3

TABLE OF CONTENTS (Continued)

SECTION V (Continued)

REFERENCE ASSEMBLY . . . . .	5-3
AMPLIFIER ASSEMBLY . . . . .	5-3
POWER AMPLIFIER HEAT SINK ASSEMBLIES . . . . .	5-4
HIGH CURRENT POWER SUPPLIES . . . . .	5-4
POWER SUPPLY ASSEMBLY . . . . .	5-4

SECTION VI  
MAINTENANCE

SERVICE INFORMATION . . . . .	6-1
FACTORY REPAIR . . . . .	6-1
SHIPPING DAMAGE . . . . .	6-1
TEST POINTS . . . . .	6-1
TROUBLESHOOTING . . . . .	6-1
CIRCUIT BREAKER TRIPS . . . . .	6-1
POOR REGULATION . . . . .	6-3
RED OVERLOAD LIGHT COMES ON . . . . .	6-3
ISOLATED GROUND OPERATION . . . . .	6-3

SECTION VII  
PARTS LIST AND DIAGRAMS

POWER SUPPLY BOARD, 601-126-4X . . . . .	7-6
REFERENCE BOARD 601-121-4X . . . . .	7-8
AMPLIFIER BOARD 601-122-4X, MODELS 6006B, 6005B, 6105B, 6106B . . . . .	7-10
AMPLIFIER BOARD 601-125-4X, MODELS 6226B, 6246B, 6225B, 6245B . . . . .	7-11
AMPLIFIER BOARD 601-127-4X, MODEL 6004B . . . . .	7-12
CHASSIS ASSEMBLY MODELS 6006B, 6105B, 6106B . . . . .	7-13
CHASSIS ASSEMBLY MODELS 6226B, 6246B, 6225B, 6245B . . . . .	7-14
CHASSIS ASSEMBLY MODEL 6004B . . . . .	7-15



LIST OF ILLUSTRATIONS

Table 1-1 AC LINE CONDITIONER ELECTRONIC SPECIFICATIONS . . . . . 1-2

Fig. 5-1 BLOCK DIAGRAM . . . . . 5-2

Fig. 6-1 ADJUSTMENT LOCATIONS . . . . . 6-2

Fig. 6-2 SCHEMATIC DIAGRAM MODELS 6006B, 6005B . . . . . 6-4

Fig. 6-3 SCHEMATIC DIAGRAM, MODELS 6226B, 6246B, 6225B, 6245B . . . . . 6-5

Fig. 6-4 SCHEMATIC DIAGRAM, MODEL 6004B . . . . . 6-6

Fig. 7-1 REFERENCE BOARD ASSEMBLY . . . . . 7-1

Fig. 7-2 AMPLIFIER BOARD ASSEMBLY, MODELS 6006B, 6005B . . . . . 7-2

Fig. 7-3 AMPLIFIER BOARD ASSEMBLY, MODELS 6226B, 6246B, 6225B, 6245B . . . . . 7-3

Fig. 7-4 POWER SUPPLY BOARD ASSEMBLY . . . . . 7-4

Fig. 7-5 AMPLIFIER BOARD ASSEMBLY 6004B . . . . . 7-5

THE UNIVERSITY OF CHICAGO LIBRARY

## SECTION I INTRODUCTION AND GENERAL DESCRIPTION

### INTRODUCTION

Elgar Series 6000B one kilo-watt AC Line Conditioners are versatile, compact, high-performance units designed for both laboratory and instrumentation system use. The series 6000B includes nine models for voltages of 100, 115, 220 and 240V, 50, 60 and 400 Hz, as specified in Table 1-1. The output voltage of each model is held constant over an unusually wide input frequency range; Model 6006B, for example, accepts an input frequency range of 57 to 63 Hz. All models offer extremely fast transient recovery time of 20 microseconds, and distortion-free sine wave output. The all solid-state circuitry generates harmonic voltages to cancel any harmonics present in the input power. The output, therefore, is not only regulated at 115V RMS (or 240V RMS) nominal output, but conditioned into a true sine wave, free from harmonics and power line transients.

The power input to the Elgar Line Conditioner can be isolated from the output ground and the chassis ground. The output ground and chassis can be isolated from each other. The double-shielded power transformer has less than one pico-farad coupling capacitance between primary and secondary windings. When isolated-ground operation is chosen, common mode voltages are held to an extremely low value.

The Elgar Series 6000B AC Line Conditioners, contained in rack-mount enclosures, provide highly regulated AC output power suitable for a var-

ety of instrumentation and system applications. The line conditioners provide short-circuit protection, regulated output over an input voltage range of 95 to 135 volts (or 190-250 volts), and visual power line monitoring with front panel voltmeters and ohmmeters.

### SCOPE OF MANUAL

This manual describes the Series 6000B AC Line Conditioner manufactured by Elgar Corporation. The manual contains operating and maintenance instructions, circuit descriptions, circuit diagrams, and parts lists. Circuits normally understood by operating technicians and field engineers and details of mechanical construction are not described.

### GENERAL DESCRIPTION

The Elgar Series 6000B AC Line Conditioner is contained in a rack-mount enclosure with meters for input/output voltage and load current monitoring, an overload indicator, and a power circuit breaker located on the front panel. Cooling air is drawn through a front panel grill, and exhausted out the rear. A rear-panel tap switch selects input voltage ranges from 95 to 135 VAC (or 180 to 260 VAC).

The enclosure contains two similar power amplifier heat sink assemblies. A silicon triac, used as an overload by pass, and a bridge rectifier assembly are mounted on the chassis. Control circuitry is mounted on three plug-in circuit boards. Test points necessary for adjustment and maintenance are available at the top of the circuit boards. The double-

shielded power transformer is located in the center of the enclosure, allowing stable weight distribution and complete electro static shielding.

Loads up to 1 KVA may be connected to the duplex output on the rear panel. A peak load current in excess of 30 amperes (15 amperes in 240V models) will initiate an overload condition. Some loads such as incandescent lamps, motors, or some electronic instruments, draw starting surges which will trip the overload circuitry. Immediately when the starting surge has passed, the line conditioner will resume normal operation. Sustained overload in excess of 1 KVA will cause the input circuit breaker to trip.

Three ground posts are located on the rear panel: OUTPUT LO, SECONDARY SHIELD-CHASSIS, and PRIMARY SHIELD. The primary shield on the transformer is connected to the grounding pins on the power input plug, and to the PRIMARY SHIELD post. The transformer secondary shield is connected to the chassis, to the grounding pin of the duplex outlet, and to the SECONDARY SHIELD post. The output low terminal is connected to the OUTPUT LO post. The line conditioner is shipped with an internal black wire jumper between all three posts. For isolated ground operation, this jumper must be clipped out and appropriate ground connections made to the three posts. The line conditioner is not intended for ungrounded operation. Read the grounding instructions, page 6-3 before attempting isolated ground operation.

TABLE 1-1. AC LINE CONDITIONER ELECTRONIC SPECIFICATIONS

MODEL	OUTPUT					FREQ. Hz	INPUT	
	POWER, VA		VOLTAGE VRMS	CURRENT			VOLTAGE RANGE <sup>(2)</sup>	CURRENT A MAX.
	CONT.	PEAK		A RMS	PEAK			
6006B	1000	5000	115	8.7	30.7	57-63	95-135	15
6106B	870	4300	100 <sup>(1)</sup>	8.7	30.7	57-63	80-120	17.5
6226B	1000	5000	220	4.5	16	57-63	180-260	8.5
6246B	1000	5000	240	4.2	14.7	57-63	200-280	8
6005B	1000	5000	115	8.7	30.7	47-53	95-135	15
6105B	870	4300	100 <sup>(1)</sup>	8.7	30.7	47-53	80-120	17.5
6225B	1000	5000	220	4.5	16	47-53	180-260	8.5
6245B	1000	5000	240	4.2	14.7	47-53	200-280	8
6004B	1000	5000	115	8.7	30.7	380-420	95-135	15

1. Rear panel switch for 115V output.
2. Input voltage ranges selected by 3 position tap switch:  
 95-115, 105-125, 115-135V for 95-135V range  
 80-100, 90-110, 100-120V for 80-120V range  
 180-220, 210-240, 220-260V for 180-260V range  
 200-240, 220-260, 240-280V for 200-280V range

Refer to this table for input output voltage ranges and output current capability for all Models referred to in text.

**SECTION II  
SPECIFICATIONS**

		MODELS 6105 6106	MODELS 6006 6005 6004	MODELS 6226 6225	MODELS 6245 6246
INPUT VOLTAGE	Three Ranges	80-120VAC 90-110VAC 100-120VAC	95-115VAC 105-125VAC 115-135VAC	180-220VAC 200-240VAC 220-260VAC	200-240VAC 220-260VAC 240-280VAC
INPUT FREQUENCY		6006,6226,6246,6106 6005,6225,6245,6105 6004	57-63 Hz 47-53 Hz 380-420Hz		
OUTPUT VOLTAGE		6006,6005,6004 6226,6225 6246,6245 6106,6105	115V AC nominal adjustable 110-120VAC 220VAC nominal adjustable 210 to 230VAC 240VAC nominal adjustable 230 to 250VAC 100VAC or 115VAC selectable by tap switch		
OUTPUT HARMONIC DISTORTION		Model 6004 All others	Less than 1% Less than 0.2%		
OUTPUT POWER		1 KVA max			
LOAD POWER FACTOR		Unity to zero leading or lagging			
LOAD CREST FACTOR		3.5 at full rated power			
REGULATION		Line $\pm$ .025% Load $\pm$ .025%			
RESPONSE TIME		20 Microseconds nominal			
NORMAL MODE REJECTION RATIO		at 1 KHz 50 db at 10 KHz 50 db			
OUTPUT ISOLATION		Less than 1 pf input to output			
AMBIENT TEMPERATURE		0 to 55°C operation — -20 to +85°C storage			
DIMENSIONS		Height: 5¼ inches Depth: 16 inches Width: 19 inches fits standard retma rack			
WEIGHT		Approximately 65 pounds			

1  
2  
3  
4  
5  
6  
7  
8  
9  
10  
11  
12  
13  
14  
15  
16  
17  
18  
19  
20  
21  
22  
23  
24  
25  
26  
27  
28  
29  
30  
31  
32  
33  
34  
35  
36  
37  
38  
39  
40  
41  
42  
43  
44  
45  
46  
47  
48  
49  
50  
51  
52  
53  
54  
55  
56  
57  
58  
59  
60  
61  
62  
63  
64  
65  
66  
67  
68  
69  
70  
71  
72  
73  
74  
75  
76  
77  
78  
79  
80  
81  
82  
83  
84  
85  
86  
87  
88  
89  
90  
91  
92  
93  
94  
95  
96  
97  
98  
99  
100

### SECTION III PRELIMINARY INSPECTION AND OPERATION

The Elgar AC Line Conditioner has been aligned, calibrated, and tested prior to shipment. The instrument is therefore, ready for immediate use upon receipt. The following checks should be made, however, to assure that the instrument has suffered no damage during shipment.

1. Make a visual inspection of the shipping container prior to accepting the package from the carrier. If extensive damage to the shipping container is evident, a description of the damage should be noted on the carrier's receipt, and signed by the driver of the carrier agent. If damage is not apparent until the instrument is unpacked, a claim for concealed damage should be placed with the carrier and all shipping containers and filler material saved for inspection. Forward a report of damage to the Elgar Service Department, which will provide instructions for repair or replacement of the instrument.
2. Make a visual inspection of the instrument when it is removed from the shipping container. If the instrument or container show signs of rough handling, remove the covers from the instrument to ensure that the circuit boards are in place and that no loose or broken components are evident.
1. Verify that the input voltage and frequency are correct for the particular model of line conditioner. If the input voltage is known, set the rear panel tap switch to the proper range. Otherwise, select the center position until input voltage is verified by the front panel voltmeter. (Step 4 below)
2. Install the line conditioner so that the flow of cooling air into the front panel grill and out the rear panel grill is unobstructed. If the power amplifier becomes overheated due to restricted air flow, the overload circuits will function, lighting the front panel OVERLOAD light and causing the line conditioner to deliver unregulated power.
3. Connect the power cord of the line conditioner to the AC power source (wall outlet). Connect any load up to 1 KVA to the duplex outlet on the rear panel of the line conditioner.
4. Set the front panel POWER switch to ON. The green pilot light will light and the front panel voltmeter will indicate the load voltage. Pressing the INPUT VOLTS button causes the voltmeter to read the input voltage so that the tap switch position can be verified. (Note incorrect setting of input range tap switch will decrease dynamic range of conditioner.)

#### OPERATION

Operating an Elgar Series 6000 Line Conditioner require only the following steps:

1  
2  
3  
4  
5  
6  
7  
8  
9  
10  
11  
12  
13  
14  
15  
16  
17  
18  
19  
20  
21  
22  
23  
24  
25  
26  
27  
28  
29  
30  
31  
32  
33  
34  
35  
36  
37  
38  
39  
40  
41  
42  
43  
44  
45  
46  
47  
48  
49  
50  
51  
52  
53  
54  
55  
56  
57  
58  
59  
60  
61  
62  
63  
64  
65  
66  
67  
68  
69  
70  
71  
72  
73  
74  
75  
76  
77  
78  
79  
80  
81  
82  
83  
84  
85  
86  
87  
88  
89  
90  
91  
92  
93  
94  
95  
96  
97  
98  
99  
100



SECTION IV  
ADJUSTMENT AND SPECIFICATION VALIDATION

OUTPUT VOLTAGE AND REFERENCE  
PHASE ADJUSTMENT

The line conditioner output voltage and reference voltage phase angle are adjustable by trimmer pots on the REFERENCE circuit board. The top cover of the line conditioner must be removed for access to these adjustments. Adjustment locations are shown in Fig. 6-1.

OUTPUT VOLTAGE ADJUSTMENT

Vary the VOLT ADJ potentiometer, R228, to set the desired output voltage. The voltage may be read on the front panel voltmeter, which has  $\pm 3\%$  accuracy or, if desired, a more accurate voltmeter may be connected to the output terminals.

The nominal output voltage of Models 6226 and 6225 is 220V RMS. It should not be adjusted beyond the limits of 210 to 230V RMS.

The nominal output voltage of Models 6246 and 6245 is 240V RMS. It should not be adjusted beyond the limits of 230 to 250V RMS.

The output voltages of Models 6106 and 6105 is 100 or 115V RMS as selected by a rear-panel tap switch.

REFERENCE VOLTAGE PHASE ADJUSTMENT

The reference voltage must be adjusted to be exactly  $180^\circ$  out of phase with the line voltage so that the power amplifier dynamic range is not used up in making quadrature output voltage. A variac of at least 10 amperes rating for 100 or 115V models or 5 amperes for 220-240V models is required to adjust the input voltage. The power amplifier output is viewed by a differential input oscilloscope connected with its ground to test point 0 (black), input A to test point 3 (orange) and input B to test point 1 (brown). The input voltage must be varied with the variac and the reference phase with R218 until a minimum signal is indicated on the oscilloscope. A perfect null cannot be obtained since the amplifier must produce harmonic voltage to cancel input harmonic distortion. At the minimum signal setting, the fundamental frequency component of the displayed signal should be nulled.

SPECIFICATION VALIDATION

To validate the line conditioner specifications, the following or equivalent test equipment is required.

1. Variac 80-135V 15a for 6006,6005,6004,6106 6105. 180-260V 7.5a for 6236,6235.
2. Differential AC voltmeter, Fluke 931.
3. Differential input oscilloscope, Tektronix 547/1A6.
4. Distortion Analyzer, HP 333A.
5. Test load, 1KW resistive.

6. Test loads, 1KVA, any power factor to zero lead or lag.

For verification of response time, the following is recommended.

7. Mercury switch, 20a.
8. Storage oscilloscope, HP 141B/1402A.

To verify the normal mode rejection, the following equipment is recommended.

9. Variable frequency AC power source, Elgar Model 1751.
10. Wave Analyzer, HP 302A.

## REGULATION SPECIFICATIONS

Output voltage should be measured with a differential AC voltmeter to obtain the high resolution necessary to measure the line conditioner voltage regulation. The output voltage should be measured at one side of the duplex outlet while the load is connected to the other side, since the outlet is the sense point for the regulation circuitry. If the output voltage is measured at the load terminals, the voltage drop in the wires to the load is usually sufficient to seriously degrade the measured regulation.

Line regulation may be measured at any value of load current from zero to 1KVA. Vary the input voltage over the full range for the selected rear-panel tap switch position. Output voltage should not vary more than  $\pm 0.025\%$ .

Load regulation is measured by varying the load from zero to 1KVA while holding line voltage constant. The load may be resistive, or any power factor to zero lead or lag. Output voltage should not vary more than  $\pm 0.025\%$ .

## HARMONIC DISTORTION

Harmonic distortion, measured at the output terminals, should be less than 0.2% for any in-

put voltage within the rated range of the line conditioner and for any load up to 1KVA

## RESPONSE TIME

Response time is measured by connecting the 1KW resistive load through a mercury switch. Connecting the load causes a fast step change in load current. Display the line conditioner output on the storage oscilloscope at a sweep speed of 50 or 100 microseconds per centimeter. Only a small segment of the waveform will be displayed. Adjust the sweep so that the waveform segment displayed is well away from the zero crossing. Place the oscilloscope in the storage mode. The switch must now be opened and closed until one of the transients so produced is captured on the oscilloscope display. The transient duration at the 90% point should be less than 20 microseconds.

## INPUT FREQUENCY RANGE

To measure the input frequency range, the line conditioner must be powered from a variable-frequency AC power source, such as the Elgar Model 1751. The rated frequency ranges are 57 to 63 Hz for 60 Hz models, 47-53 Hz for 50 Hz models, and 380-420 Hz for 400 Hz models. At both extremes of the frequency range, the line conditioner should meet its line regulation specifications of  $\pm 0.025\%$ .

## NORMAL MODE REJECTION

Normal mode rejection is measured by powering the AC line conditioner from an electronic AC power source, such as the Elgar Model 1751, which produces a power line signal having a high-frequency disturbance component of about 5V RMS amplitude mixed with it. A wave analyzer is used to compare the amplitude of the high frequency signal at the input of the line conditioner to the amplitude at the output. The attenuation of the line conditioner should be greater than 50 db at either 1KHZ or 10KHZ.

## SECTION V THEORY OF OPERATION

The Series 6000B AC Line Conditioner operates as an operational amplifier to slave the output voltage to an internally-generated stable, harmonic-free AC reference voltage. The majority of the output power is supplied by the shielded 1KVA transformer, T1. The amplifier is connected in series with the transformer output to supply the difference power, boosting or bucking the transformer voltage to correct the output.

### BLOCK DIAGRAM DESCRIPTION

A block diagram of the Series 6000B line conditioner is shown in Figure 5-1. Input power is applied to the primary of a double-shielded power transformer. The transformer has three secondary windings; one supplies the low-current power supplies for the reference and pre-amplifier circuits, another supplies the high-current power supplies for the power amplifier stage, and the third supplies the majority of the AC output power. The transformer's shielding allows less than one picofarad capacitive coupling between primary and secondary windings.

The reference voltage is synchronized by a sample of the AC input voltage taken from the low-voltage secondary winding. The synchronizing voltage is passed through an electronic phase servo which compensates for any phase variation in the reference filter.

The phase-shifted synchronizing signal drives a square-wave clipper which produces a symmetrical, constant amplitude square-wave. The square-wave is filtered in a two-stage active fil-

ter to remove the harmonics, producing a pure, stable sine wave reference voltage.

Long-term stability of the reference voltage is assured by an amplitude control loop. A precision rectifier produces a DC voltage proportional to the reference voltage. This voltage is compared to the voltage from a reference zener diode, and the error applied to an integrating amplifier which controls the amplitude of the square-wave.

The phase angle of the reference voltage is compared to the synchronizing signal in a phase detector which provides error voltage to the electronic phase servo.

The output voltage of the line conditioner is compared to the reference voltage in current summing resistors on the amplifier circuit board. Any error in the output voltage is amplified by the pre-amplifier and power amplifier to produce a correction in the output. Thus, the line conditioner output is a true replica of the reference voltage.

### CIRCUIT DESCRIPTION

The schematic for Models 6006B and 6005B is shown in Fig. 6-2. The schematic for Models 6226B, 6246B, 6225B, and 6245B is shown in Fig. 6-3. The schematic for Model 6004B is shown in Fig. 6-4. The schematic for Models 6105B and 6106B is shown in Fig. 6-5. These schematics should be used with the following circuit descriptions.

#### POWER INPUT CIRCUIT

AC power input is applied to the line conditioner through the input power cord and circuit breaker

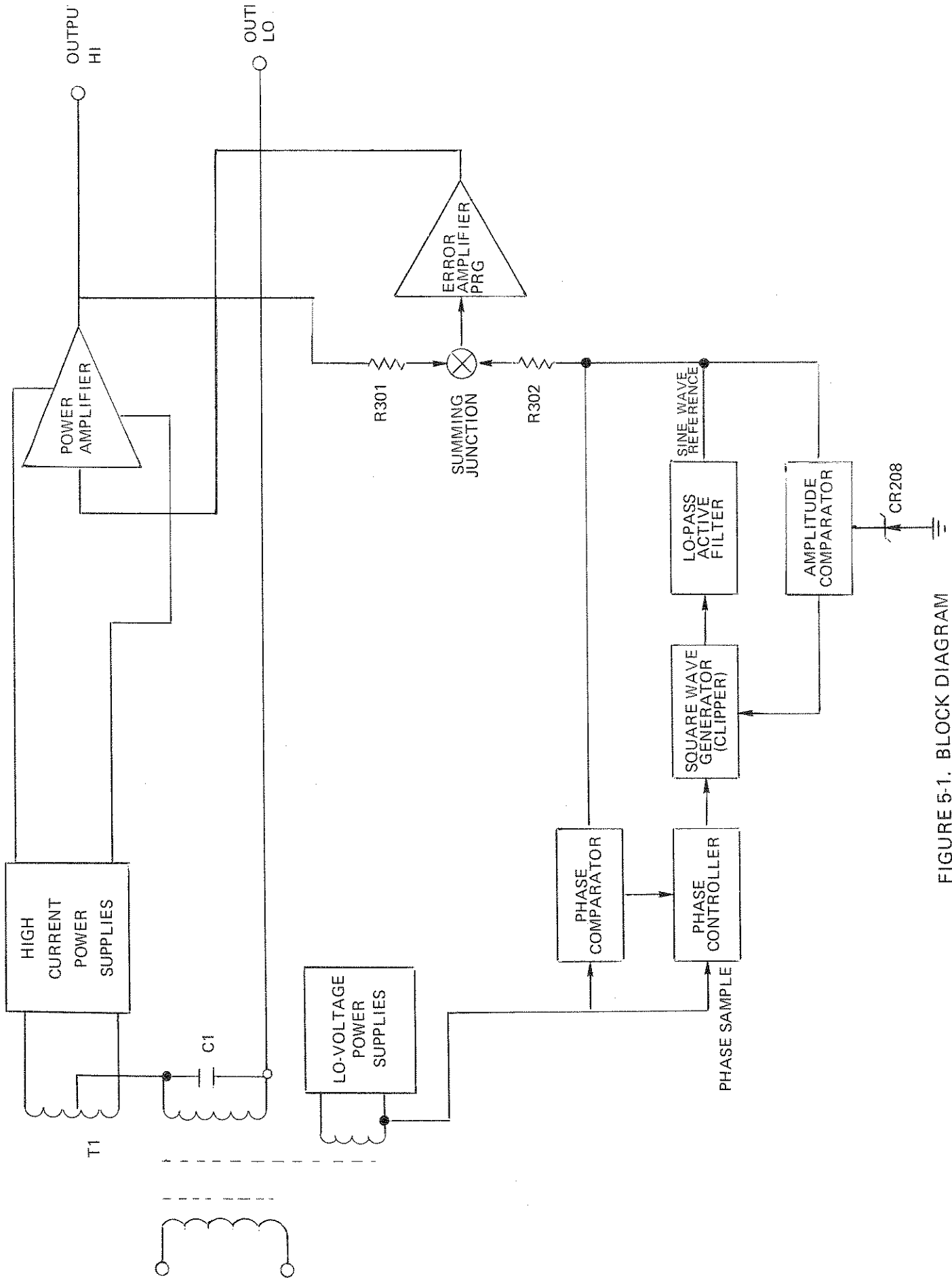

FIGURE 5-1. BLOCK DIAGRAM

5-2

CB1. The input power is applied to the primary through tap switch S1. S1, mounted on the rear panel, permits the line conditioner to deliver its rated output voltage with various input voltage levels.

## POWER TRANSFORMER

The power transformer, T1, has three secondary windings, one for the low-voltage power supplies for the reference and pre-amplifier circuits, one for the high-current power supplies for the power amplifier stage, and the main secondary, which provides the majority of the AC output power. C1, across the main secondary windings, serves as a power supply bypass for the power amplifier, since this winding is connected in series with the high-current power supply return, and also provides some filtering for power line transients.

## REFERENCE ASSEMBLY

The reference synchronizing signal is taken from the low voltage secondary of T1. This signal is passed through a low-pass filter consisting of R201, R202, C201, and C202. This filter provides approximately  $90^\circ$  phase lag and reduces the effect of high-frequency line disturbances on the reference. The signal from C202 is applied to two circuits; to Q201 which acts as a square-wave clipper to drive phase detector Q202, and to the phase shift network associated with all-pass phase shifter Z201. The phase shift in Z201 is controlled by the phase servo varying the resistance of photomodulator V201. The signal from Z201 drives clipper Q204 which generates the reference square-wave. The amplitude of the square-wave is determined by the collector supply voltage of Q201, which comes from integrator Z203.

The square-wave is buffered by emitter follower Q205 and applied to a 2-stage active low pass filter consisting of Z203 and Z206 with their associated resistors and capacitors. This active filter removes the harmonics of the square-wave, leaving a pure sinewave with about .15% harmonic distortion. The refer-

ence sine wave is applied to phase comparator Q202, precision rectifier Z205, and to the comparison circuit on the amplifier board.

Phase comparator Q202 operates as a half-wave phase detector to determine whether the reference voltage is exactly  $180^\circ$  out of phase with the AC line voltage. Any phase error results in a DC signal from Q202, which is applied to integrator Z202 to control photomodulator V201. R218 provides an adjustment for precisely setting the phase angle.

Precision rectifier Z205 produces a rectified DC signal at CR206 proportional to the amplitude of the reference voltage. This voltage is compared to the voltage from reference zener, CR205, in integrator Z203. Resistor R230 bypasses some reference signal around Z205 to give the effect of full wave rectification. The output of integrator Z203 furnishes the collector supply voltage to square-wave clipper Q204, forming a feedback loop which corrects any error in the reference amplitude. The reference amplitude is adjusted by R228 to set the output voltage of the line conditioner.

## AMPLIFIER ASSEMBLY

In the amplifier assembly, the reference voltage is compared to the line conditioner output voltage in summing resistors R301 and R302. The error voltage at the junction of these resistors is amplified in operational amplifier Z301 and applied to the power amplifier driver circuitry. Since the power supply return for the power amplifiers is bootstrapped to the main secondary winding of T1, the power amplifier driver circuitry must withstand the full peak-to-voltage swing of the line conditioner output. The emitter of Q302 is therefore returned through CR307 to the negative high-current power supply during the negative swing of the output. During these positive half-cycles, the emitter of Q302 is clamped by CR302 to  $-15V$ . Q301 amplifies the error signal and shifts its level to that of Q302 base. In 220V and 240V models, the higher voltage swing requires Q305 to be placed in series with Q301. The signal at the collector of Q302 is amplified by emitter follower Q302 and applied to the upper heat sink assembly for positive half-cycle output. For negative half-cycle, the signal at the collector of Q302 is inverted by

Q304 and applied to the lower heat sink assembly.

## POWER AMPLIFIER HEAT SINK ASSEMBLIES

The two power amplifier heat sink assemblies are identical and interchangeable, with the exception that one heat sink has a thermostat installed for overtemperature sensing. The thermostat may be installed in either heat sink assembly.

In 115V Models 6006B, 6005B and 6004B, each heat sink assembly consists of a power emitter follower driving four power amplifier transistors in parallel. The diode connected across the power transistors protects them from reverse voltages which may occur if the line conditioner is turned on with the output shorted, and from severe transients which may occur when an inductive load is switched.

In 220V and 240V models, the higher voltage requirement in the power amplifier is met by series-parallel operation of four power transistors. Each transistor pair is driven by a power emitter follower. The lower emitter follower receives its signal from the amplifier circuit board assembly. The upper emitter follower is driven by voltage-divider resistors mounted on the chassis.

The two heat sink assemblies are connected as a series-push-pull class B amplifier with the output taken from the junction of the upper heat sink emitters and lower heat sink collectors.

## HIGH CURRENT POWER SUPPLIES

The power amplifier operates from positive and negative unregulated high-current power supplies consisting of bridge rectifier assembly CR1 thru CR4, filter capacitor C2 and C3, and bleeder resistors R1 and R2. The common return of these power supplies is connected to the main secondary winding of T2. The power supply voltages are approximately  $\pm 45V$  DC in Models 6006B, 6005B, 6004B, 6106B and 6105B and  $\pm 90V$  DC in Models 6226B and 6246B.

## POWER SUPPLY ASSEMBLY

The power supply circuit board assembly contains rectifier and regulation circuits for the  $\pm 15V$  DC power supplies, and protection circuitry for the power amplifier.

In the  $-15V$  power supply, diodes CR105 and CR106 rectify the voltage from the low voltage winding of T1 and provide approximately 20V DC to filter capacitor C104. This voltage is regulated to  $-15V$  by series pass transistor Q102. Q102 is driven by operational amplifier Z102 which compares the  $-15V$  output to the voltage from zener diode CR101 to derive the control signal. Resistors R112 and R113 and CR102 form a starting circuit to ensure that the regulator starts when power is applied.

The  $+15V$  regulator operates from approximately  $+20V$  DC from rectifier CR103 and CR104 and filter capacitor C103. The series pass transistor, Q101 is controlled by operational amplifier Z101 which compares the  $+15V$  output to the  $-15V$  output.

The line conditioner protective circuitry provides gate signals to two triacs. In the event of an overload, or short circuit, triac CR5 is fired to bypass overload currents around the power amplifier and CR302 on the amplifier circuit board is fired to turn off the drive signals to the power amplifier. While the triacs are conducting, the line conditioner delivers unregulated power. Triac triggering is controlled by overload flip-flop, Z104. Q106 and Q107 provide current amplification for the triac trigger and overload indicator lamp.

The overload flip-flop is set by over-current, over-voltage or over-temperature conditions. Over-current is sensed by comparator Z103 in conjunction with current transformer T2 and rectifiers CR115 thru CR118. Maximum instantaneous current is 30 amperes for Models 6006B, 6005B, 6004B, 6106B and 6105B, and 16 amperes for Models 6226B, 6246B, 6225B and 6245B.

Over-voltage is sensed by Q105 in conjunction with zener diode CR111. If the voltage at the power amplifier output is sufficient to break down CR111, Q105 turns on, setting the flip-flop.

Over-temperature in the power amplifier heat sink is sensed by thermostat S401, which sets the overload flip-flop.

Transistors Q103 and Q104 sense the zero-crossing of the power amplifier output voltage and generate a flip-flop reset pulse at each positive-to-negative zero crossing. Thus, the flip-flop is reset within one cycle after the overload condition disappears.

1  
2  
3  
4  
5  
6  
7  
8  
9  
10  
11  
12  
13  
14  
15  
16  
17  
18  
19  
20  
21  
22  
23  
24  
25  
26  
27  
28  
29  
30  
31  
32  
33  
34  
35  
36  
37  
38  
39  
40  
41  
42  
43  
44  
45  
46  
47  
48  
49  
50  
51  
52  
53  
54  
55  
56  
57  
58  
59  
60  
61  
62  
63  
64  
65  
66  
67  
68  
69  
70  
71  
72  
73  
74  
75  
76  
77  
78  
79  
80  
81  
82  
83  
84  
85  
86  
87  
88  
89  
90  
91  
92  
93  
94  
95  
96  
97  
98  
99  
100



## SECTION VI MAINTENANCE

### SERVICE INFORMATION

Questions concerned with the operation, repair or servicing of this instrument should be directed to the nearest Elgar representative, or to the Service Department, Elgar Corporation, 9250 Brown Deer Rd., San Diego, California 92121. **INCLUDE THE MODEL NUMBER AND SERIAL NUMBER** in any correspondence concerning this instrument

### FACTORY REPAIR

Should it be necessary to return an instrument to the factory for repair, please contact the Elgar Corporation Service Department for authorization to make shipment.

**DO NOT RETURN THE UNIT FOR REPAIR WITHOUT AUTHORIZATION.**

Elgar Corporation  
9250 Brown Deer Rd.  
San Diego, California 92121

### SHIPPING DAMAGE

It is possible for the equipment to be damaged in shipment. Therefore, it is imperative that the instrument be tested and inspected as soon as it is received. If the instrument shows signs of damage, notify the carrier immediately. The carrier's claim agent will prepare a report of damage to be forwarded to the Elgar Service Department. You will be advised as to the action necessary to have the instrument repaired or replaced.

### TEST POINTS

Circuit operation for each major assembly can be tested through the convenient test points provided at the tops of the plug-in circuit boards. Test point locations are shown in Fig. 6-1. The correct voltage indication at each test point is given in the following list:

- TP0-Black-output LO-common for all measurements
- TP1-Brown-Power transformer main secondary-115 or 230V unregulated line
- TP3-Orange-Regulated output-115V or 220/240 RMS sinewave
- TP4-Yellow-Reference sine wave-approximately 3V RMS sinewave

Test points are not provided for the high-current power supplies. The voltage may be measured on the filter capacitors C2 and C3 at the bottom of the instrument. These voltages are unregulated and will vary from plus and minus 37V DC to plus and minus 50V DC, with as much as 10V peak ripple. (Plus and minus 74-100V DC in 220/240V models.)

The correction voltage generated by the power amplifier may be viewed with a differential input oscilloscope between test point 1 and test point 3

### TROUBLESHOOTING

#### CIRCUIT BREAKER TRIPS

The line conditioner may be overloaded or the output short circuited. Some loads, particularly motors,

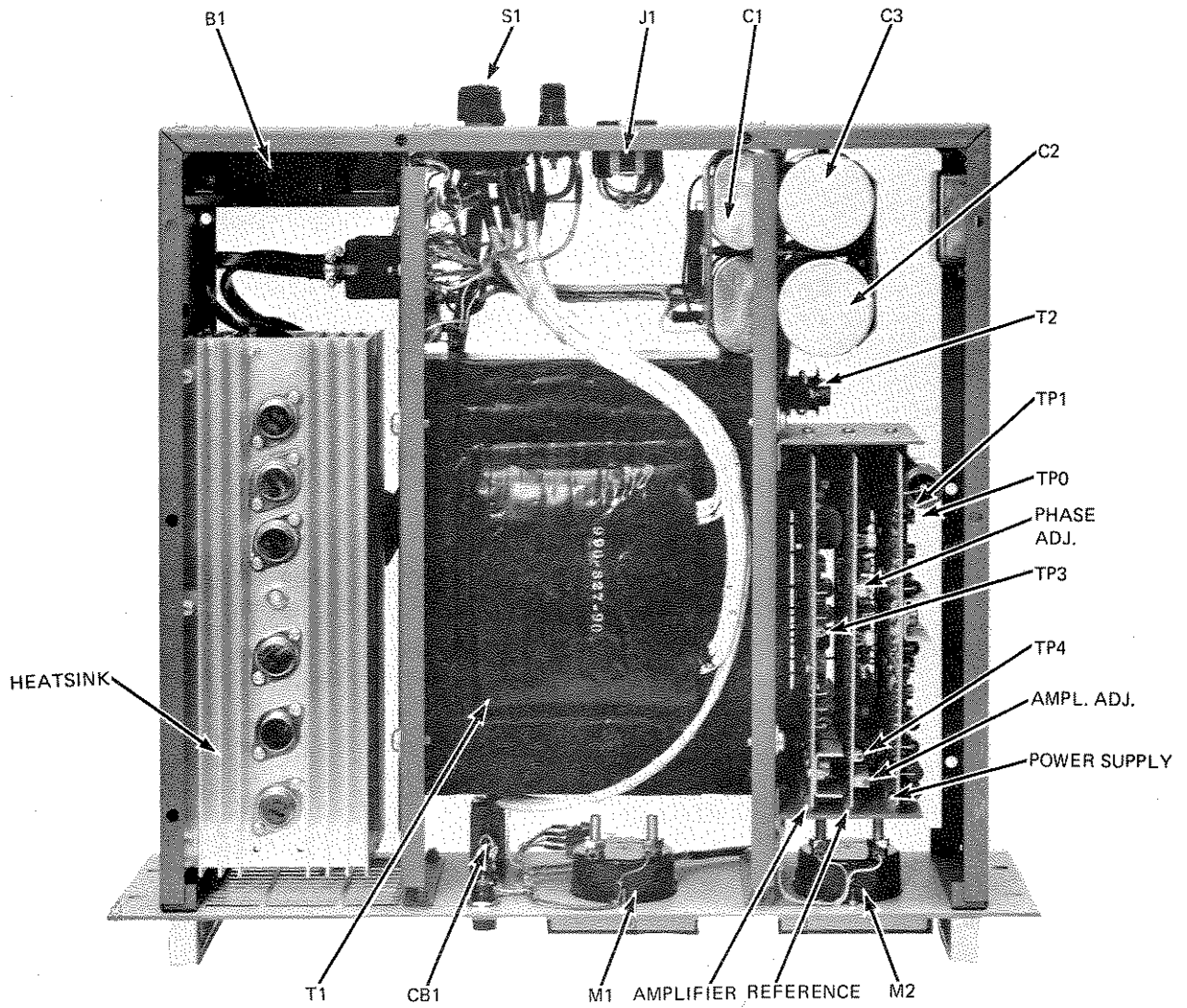

FIGURE 6-1. ADJUSTMENT LOCATIONS

which have running power ratings less than 1KVA may draw enough starting surge to trip the circuit breaker.

If the circuit breaker continues to trip with the load disconnected, there is a fault in the internal power circuitry. Unplug the heat sink assemblies and see if circuit breaker still trips. If it does, suspect a shorted component in the high current power supplies, such as bridge rectifier assembly CR1 through CR4 or filter capacitors C2 and C3.

If the circuit breaker does not trip when the heat sinks are disconnected, suspect a shorted power transistor on one of the heat sinks, or a shorted triac, CR5. These components can be tested with an ohmmeter.

### POOR REGULATION

Make sure load regulation is measured at line conditioner output terminals.

Excessive peak load currents may trip the overload protection circuitry. In this case, the front panel overload lamp will be lit.

Power amplifier may be clipping. Observe the correction voltage waveform between test point 1 and test point 3. Clipping may be caused by improper reference phase angle adjustment, input harmonic distortion in excess of 10%, or input voltage tap switch in incorrect position. See page 4-2 for reference phase angle adjustment procedure.

If the correction voltage is nearly square-wave, suspect a malfunction in the reference board, causing improper reference voltage.

### RED OVERLOAD LIGHT COMES ON

This may be caused by overload, excessive input voltage, or overheating. Overheating may be caused by obstructed air flow or cooling air in excess of 55°C. DO NOT operate the line conditioner in a closed cabinet with no provision for cooling air flow.

### ISOLATED GROUND OPERATION

In building wiring systems, the power line LOW wire is grounded to earth at the main switch panel.

Load currents flowing in the power line LO wiring cause voltage drops, so that, at wall outlets in the building, the LO terminal is no longer exactly at earth potential. The LO terminal voltage appears as a common mode voltage at the wall outlet connections, frequently containing transients, as well as steady state voltage components. The ground wire connected to the grounding pin on wall outlets does not carry load currents and therefore may be expected to be nearer earth potential than power line LO terminal. In the line conditioner, the output LO terminals is not connected to the power line LO terminal, but rather to the ground wire terminal of the wall outlet, thus re-establishing the output LO terminal at ground potential. Since the power in the line conditioner is transformer coupled, the line conditioner load currents are localized and do not flow in the power outlet ground wiring.

Some transient voltage may appear between the power outlet ground terminal and earth ground due to stray capacitive and inductive coupling in the building wiring. Some highly sensitive instrumentation systems are disturbed by these transients and it becomes desirable to ground the system to a separate earth ground. When this is done, the line conditioner must be connected for isolated ground operation so that disturbances from the power line ground connection will not be propagated into the instrumentation system. To do this, the black wire inside the line conditioner which connects the three rear-panel ground posts must be clipped out. If the earth ground connection for the instrumentation system is short, the SECONDARY SHIELD CHASSIS and OUTPUT LO posts may be jumpered together and connected to the instrumentation system ground.

Since the SECONDARY SHIELD connection may carry a milliamperere or so of capacitive current, a separate earth ground connection may be desirable for the SECONDARY SHIELD if the ground connection from the instrumentation system is long. The OUTPUT LO post is left connected to the instrumentation system ground. If the SECONDARY SHIELD is separately grounded, the line conditioner chassis must be isolated from the instrumentation system ground, since it is connected to the SECONDARY SHIELD

1  
2  
3  
4  
5  
6  
7  
8  
9  
10  
11  
12  
13  
14  
15  
16  
17  
18  
19  
20  
21  
22  
23  
24  
25  
26  
27  
28  
29  
30  
31  
32  
33  
34  
35  
36  
37  
38  
39  
40  
41  
42  
43  
44  
45  
46  
47  
48  
49  
50  
51  
52  
53  
54  
55  
56  
57  
58  
59  
60  
61  
62  
63  
64  
65  
66  
67  
68  
69  
70  
71  
72  
73  
74  
75  
76  
77  
78  
79  
80  
81  
82  
83  
84  
85  
86  
87  
88  
89  
90  
91  
92  
93  
94  
95  
96  
97  
98  
99  
100

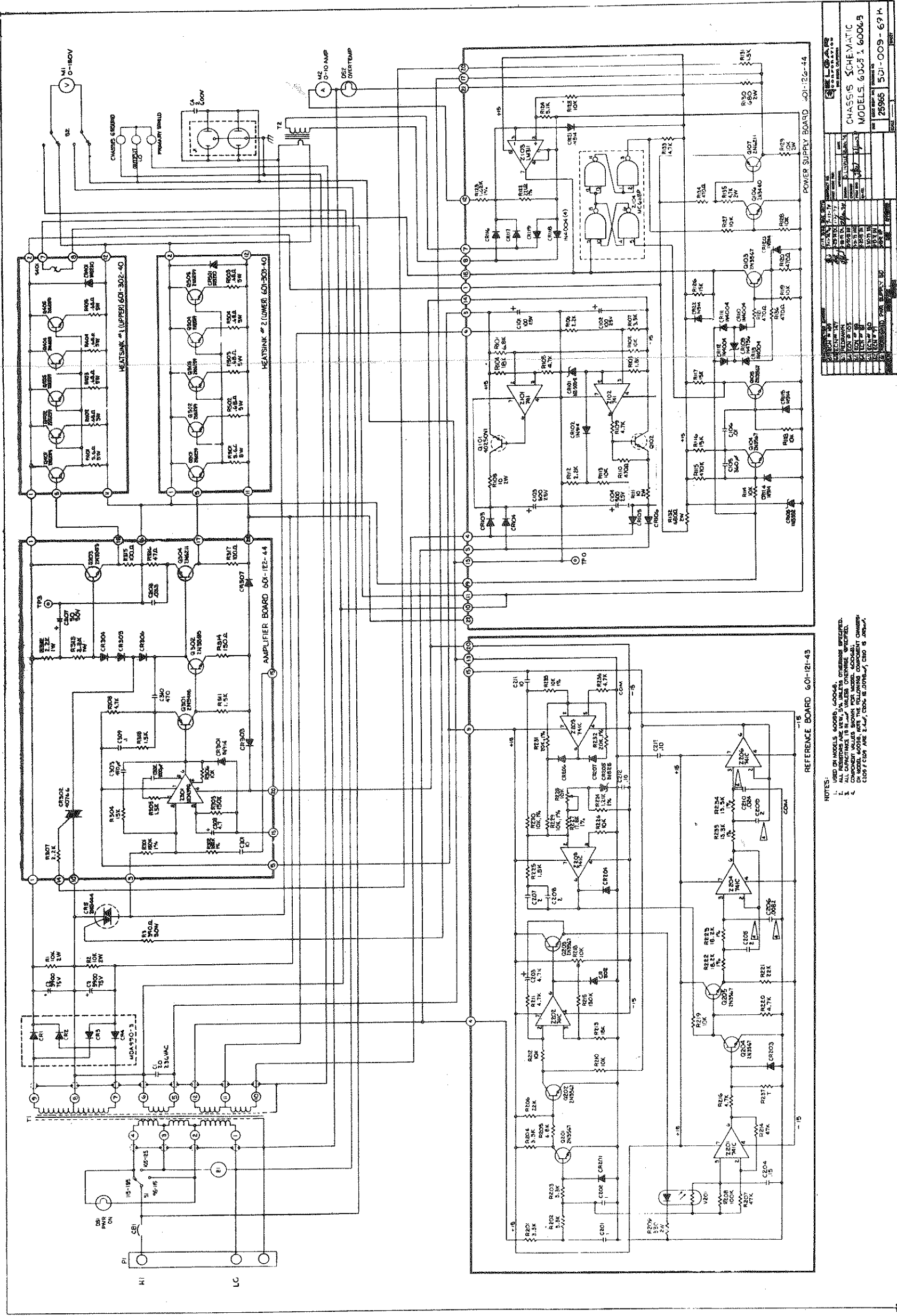

NO.	DESCRIPTION	QTY.	REF. NO.	REVISION
1	CHASSIS SCHEMATIC			
2	MODELS 6005B, 6006B			
3	25985			
4	501-009-69H			

NOTES:  
 1. USED IN MODELS 6005B, 6006B.  
 2. ALL DIMENSIONS IN INCHES UNLESS OTHERWISE SPECIFIED.  
 3. COMPONENT VALUES SHOWN FOR MODEL 6005B.  
 4. COMPONENT VALUES SHOWN FOR MODEL 6006B.

FIGURE 6-2. SCHEMATIC DIAGRAM MODELS 6006B, 6005B



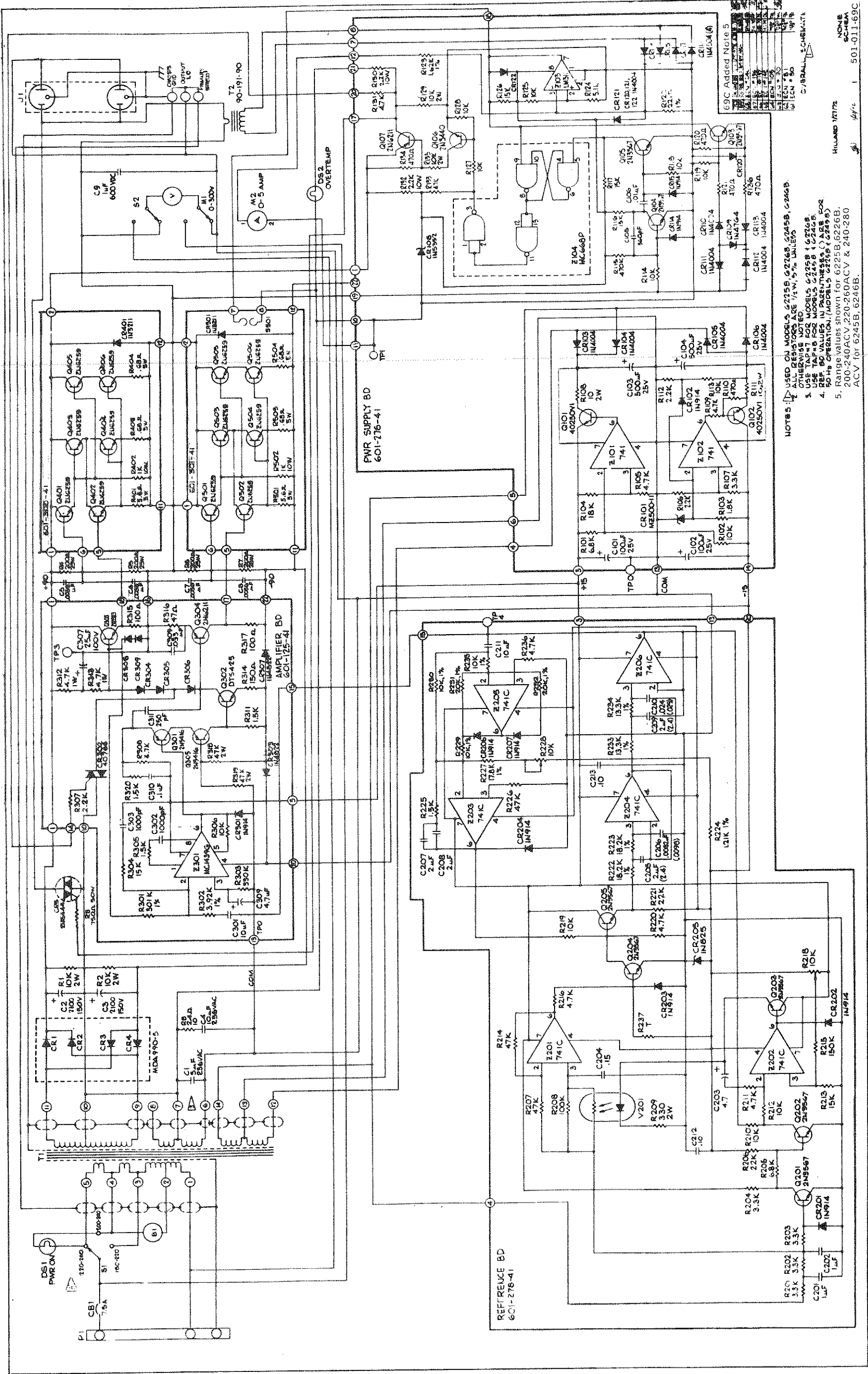

- NOTES:
1. USED ON MODELS 6225B, 6246B, 6245B, 6246B.
  2. OTHERWISE NOTED.
  3. USE TAP #7 FOR MODELS 6225B & 6246B.
  4. USE TAP #8 FOR MODELS 6245B & 6246B.
  5. RANGE VALUES SHOWN FOR 6225B, 6226B, 200-240ACV, 220-260ACV & 240-280 ACV FOR 6245B, 6246B.

FIGURE 6-3. SCHEMATIC DIAGRAM MODELS 6226B, 6246B, 6225B, 6245B





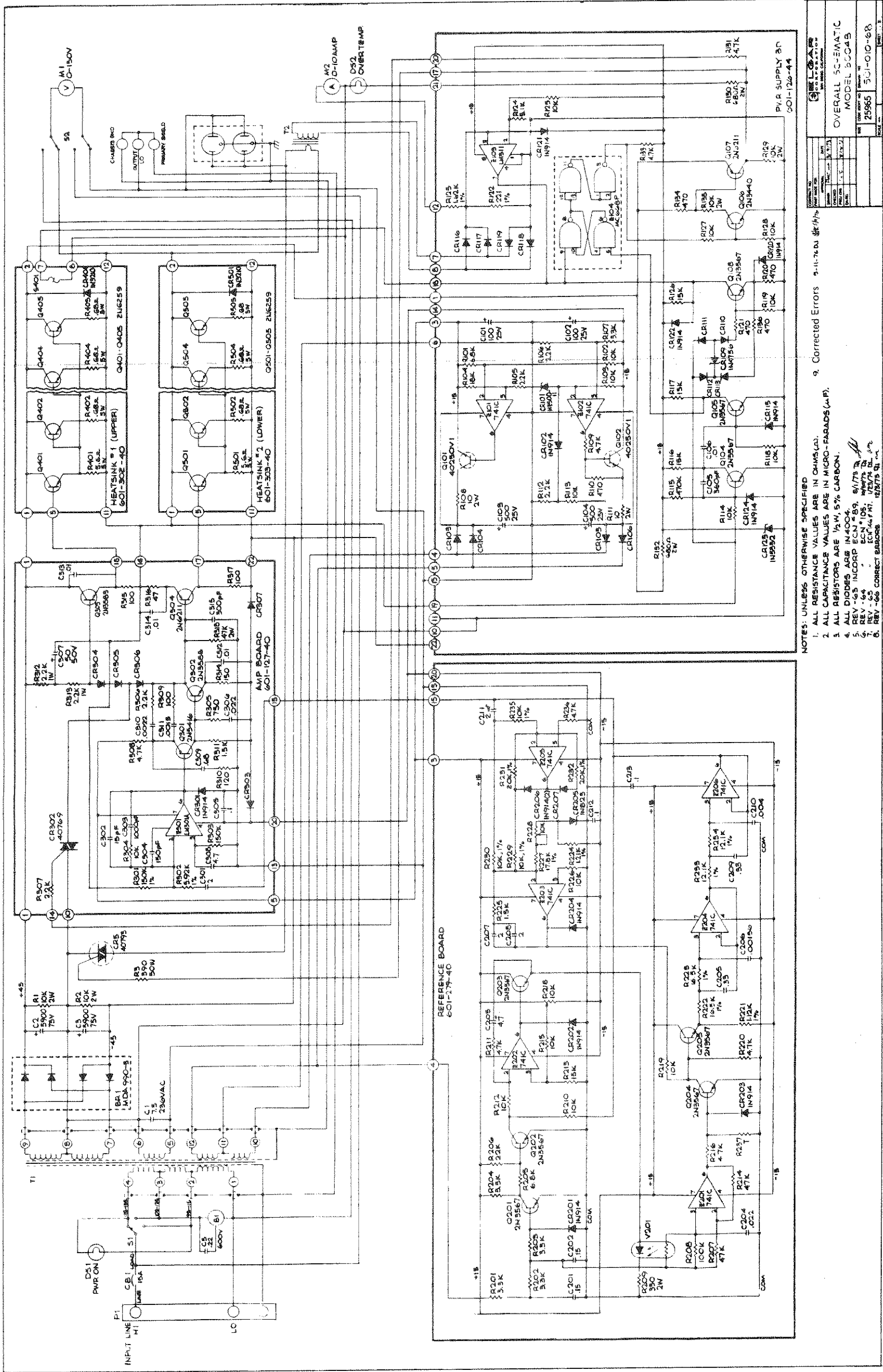

NOTES: UNLESS OTHERWISE SPECIFIED

1. ALL RESISTANCE VALUES ARE IN OHMS (Ω).
2. ALL CAPACITANCE VALUES ARE IN MICRO-FARADS (μF).
3. ALL RESISTORS ARE 1/4W, 5% CARBON.
4. ALL DIODES ARE IN4004.
5. REV -65 INCORP ECN #89.
6. REV -64 ECN #105.
7. REV -63 ECN #107.
8. REV -62 CORRECT BARBERS.
9. CORRECTED ERRORS 5-11-76-DJ.

MODEL 6004B  
 OVERALL SCHEMATIC  
 MODEL 6004B  
 25965 301-010-68  
 100%

FIGURE 6-4. SCHEMATIC DIAGRAM, MODEL 6004B



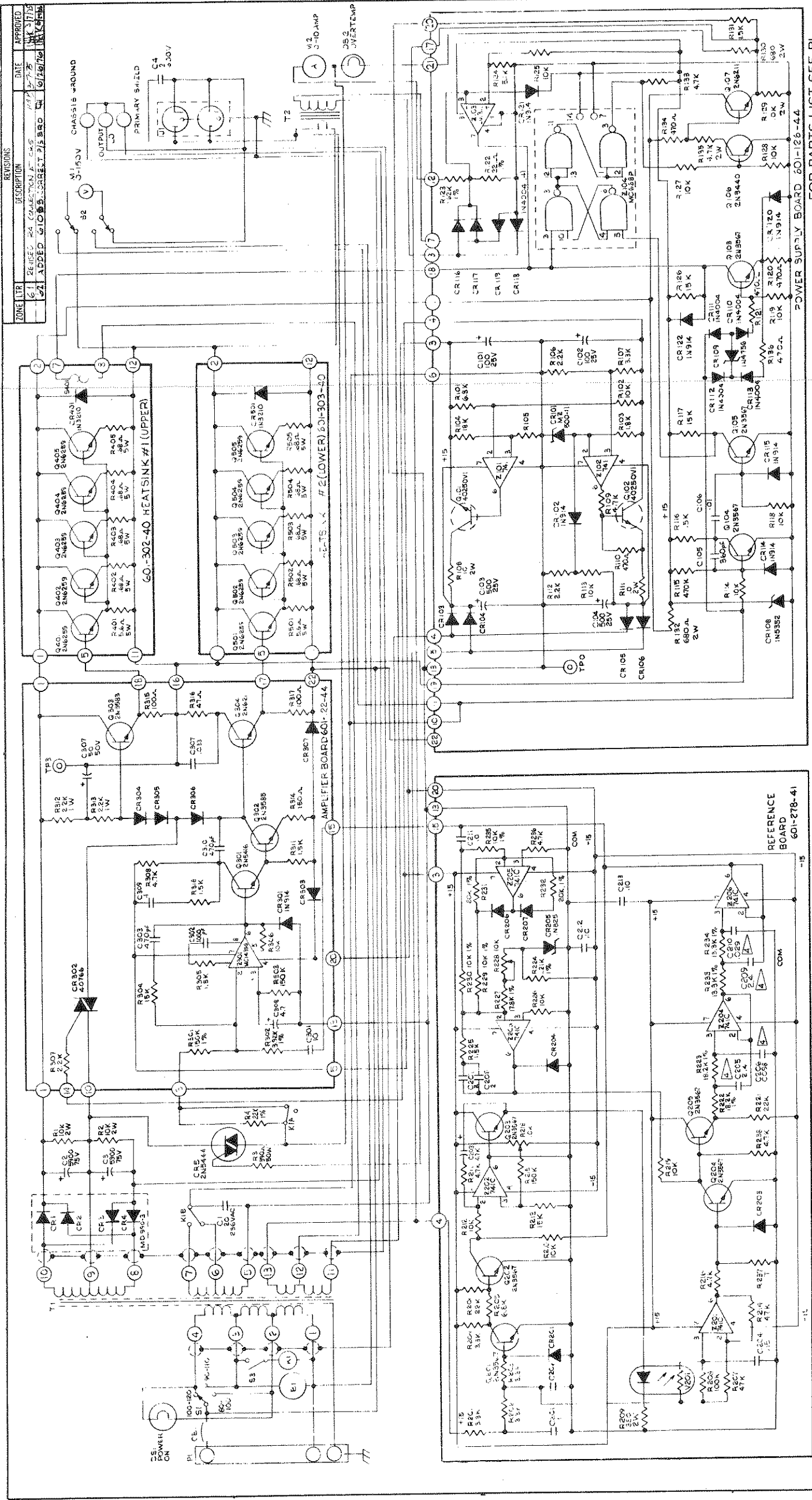

FOR PARTS LIST SEE PL

CONTRACT NO.	UNLESS OTHERWISE SPECIFIED DIMENSIONS ARE IN INCHES
FIRST MADE FOR	DECIMALS - FRACTIONS
APPROVAL	XX ± 0.3 ± 1/32 ± 1/25
DRAWN	XXX ± 0.10 DO NOT SCALE THIS DRAWING
CHECKED	MATERIAL:
PROJ. ENG.	USED ON:
QA-REL.	FINISH:
	AND IN THE PROPERTY OF HELIX CORPORATION AND SUBJECT TO THE PATENT RIGHTS OF HELIX CORPORATION. THIS DRAWING IS THE PROPERTY OF HELIX CORPORATION. IT IS TO BE USED ONLY FOR THE MANUFACTURE AND REPAIR OF THE EQUIPMENT SPECIFIED HEREON. IT IS NOT TO BE REPRODUCED OR TRANSMITTED IN ANY FORM OR BY ANY MEANS, ELECTRONIC OR MECHANICAL, INCLUDING PHOTOCOPYING, RECORDING, OR BY ANY INFORMATION STORAGE AND RETRIEVAL SYSTEM.

HELIX CORPORATION  
SAN DIEGO, CALIFORNIA

CHASSIS SCHEMATIC  
MODEL 6105 & 6106B

SIZE CODE IDENT NO. DRAWING NO. SCALE SHEET 1 OF 1  
D 25965 501-020-62

NOTES:

1. ALL RESISTORS ARE 1/2W, 5% UNLESS OTHERWISE SPECIFIED.
2. ALL CAPACITANCE IS IN  $\mu$ F UNLESS OTHERWISE SPECIFIED.
3. ALL RECTIFIERS ARE IN914 UNLESS OTHERWISE SPECIFIED.
4. COMPONENT VALUES SHOWN ARE FOR 6105B (601-278-4X REFERENCE BOARD ASSY). FOR 6106B (601-121-4X) C205 & C209 ARE 2.0  $\mu$ F, C206 IS 0.008  $\mu$ F & C210 IS 0.024  $\mu$ F.

FIGURE 6-5. SCHEMATIC DIAGRAM, MODELS 6105B, 6106B



**SECTION VII**  
**PARTS LIST AND DIAGRAMS**

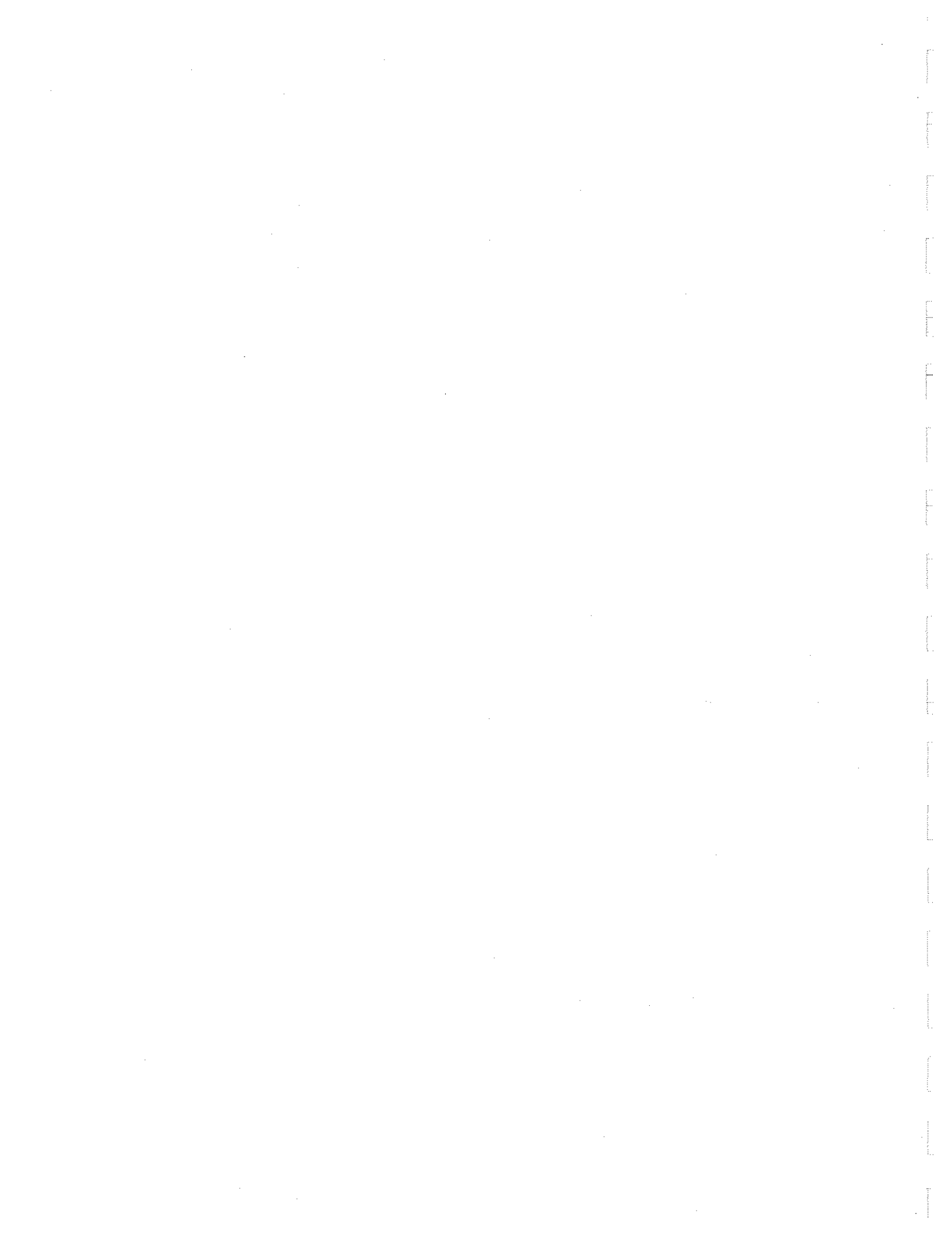

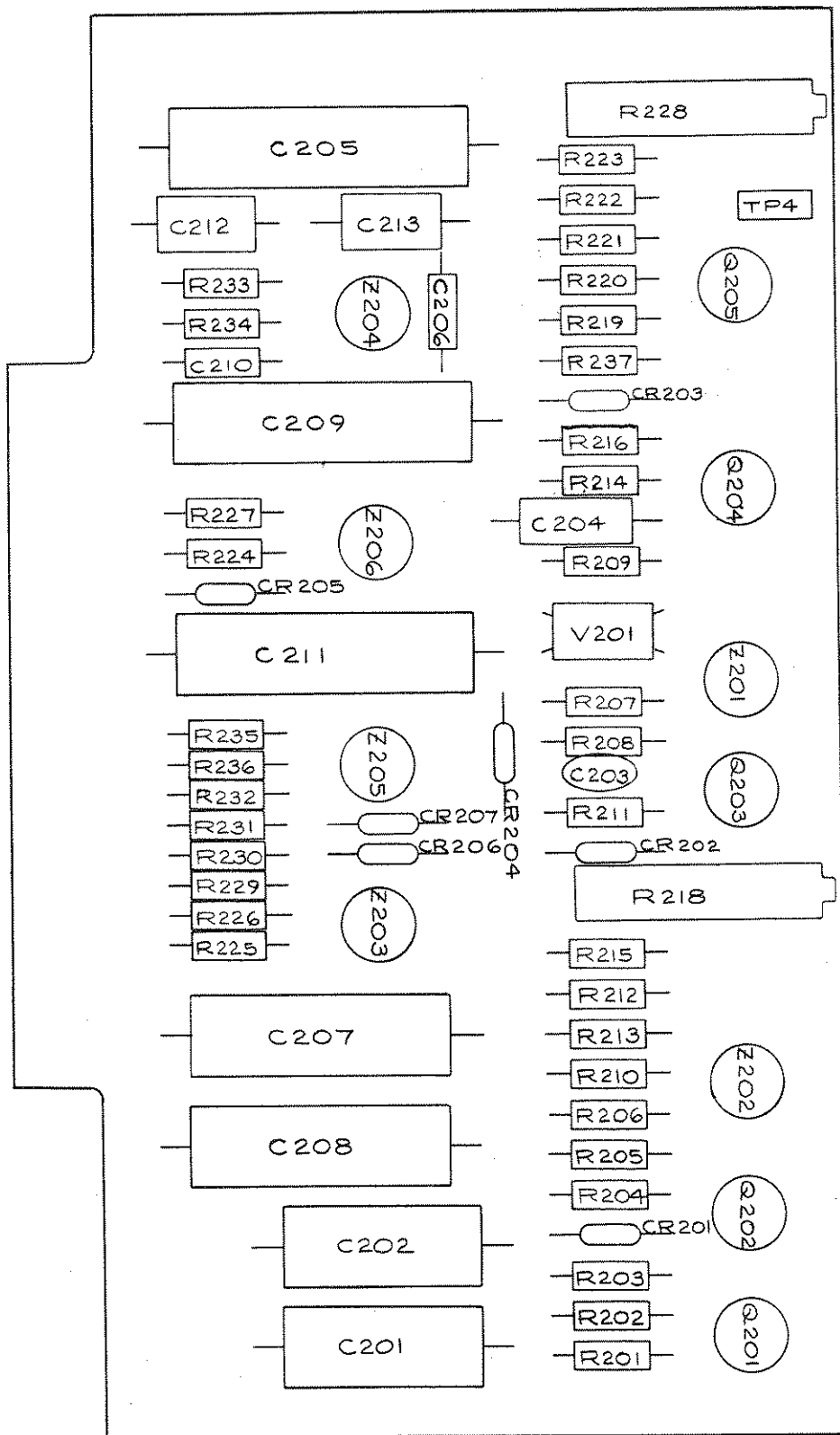

FIGURE 7-1. REFERENCE BOARD ASSEMBLY

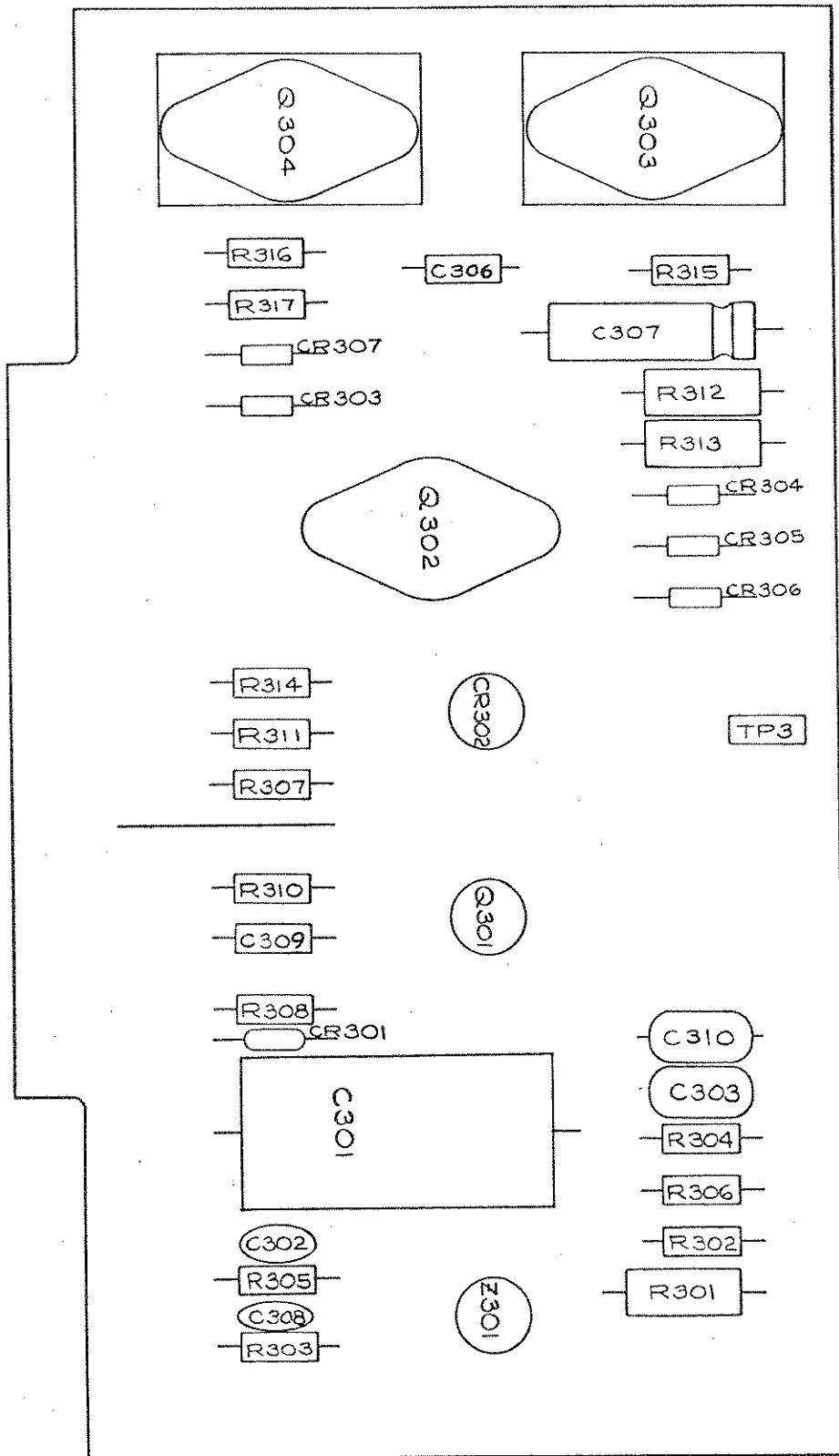

FIGURE 7-2. AMPLIFIER BOARD ASSEMBLY, MODELS 6006B, 6005B, 6106B, 6015B



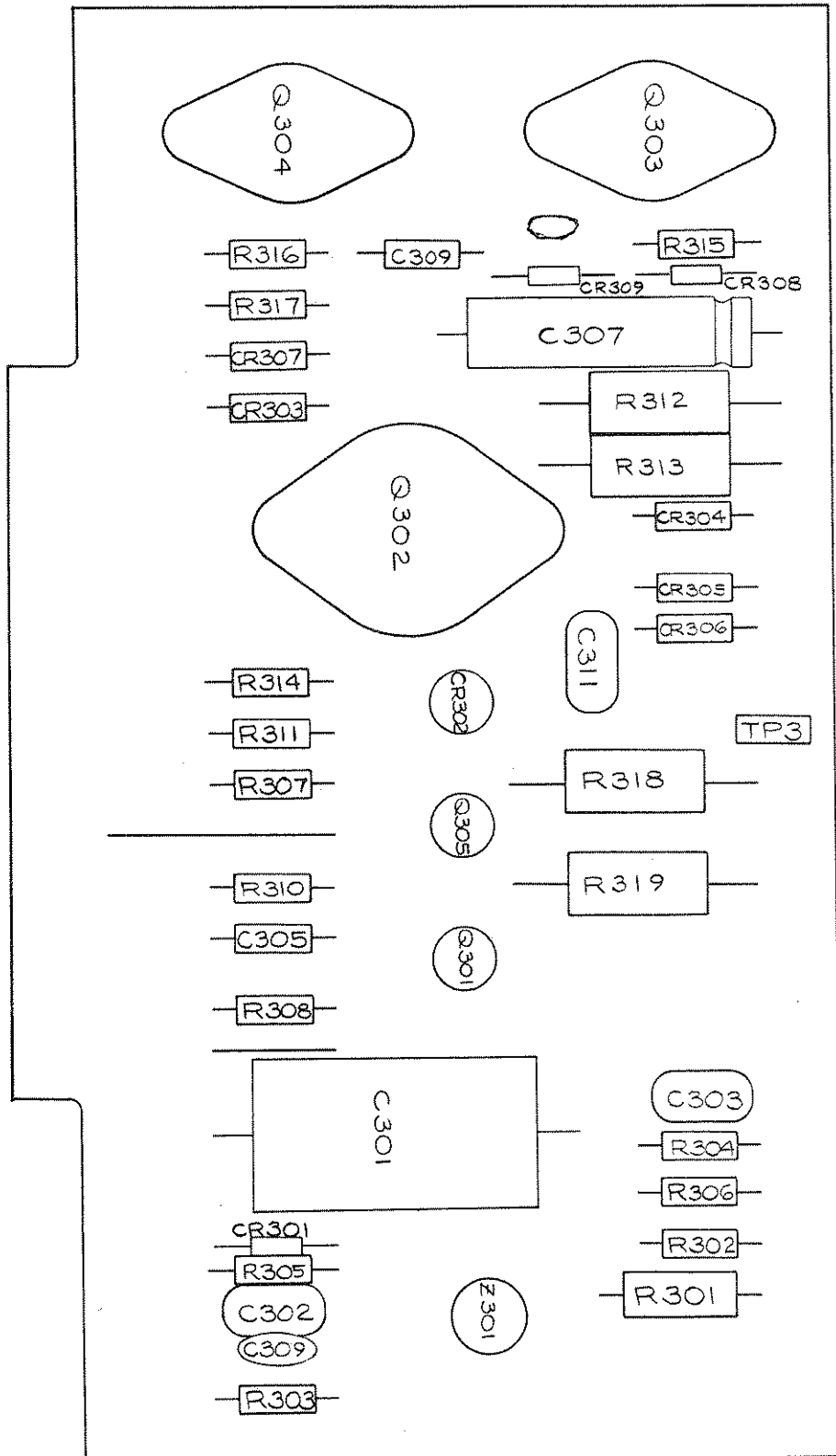

FIGURE 7-3. AMPLIFIER BOARD ASSEMBLY, MODELS 6226B, 6246B, 6225B, 6245B

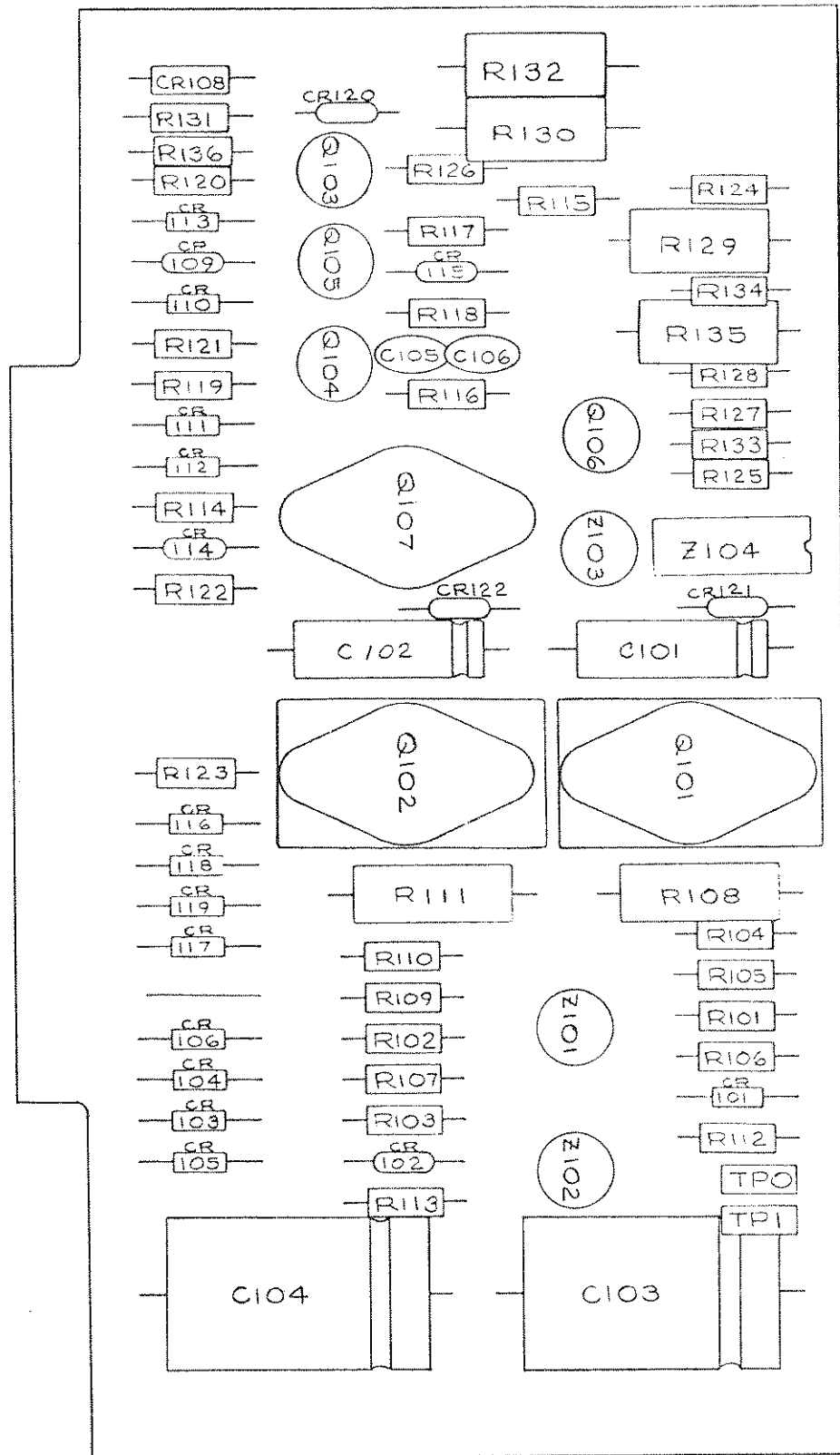

FIGURE 7-4. POWER SUPPLY BOARD ASSEMBLY

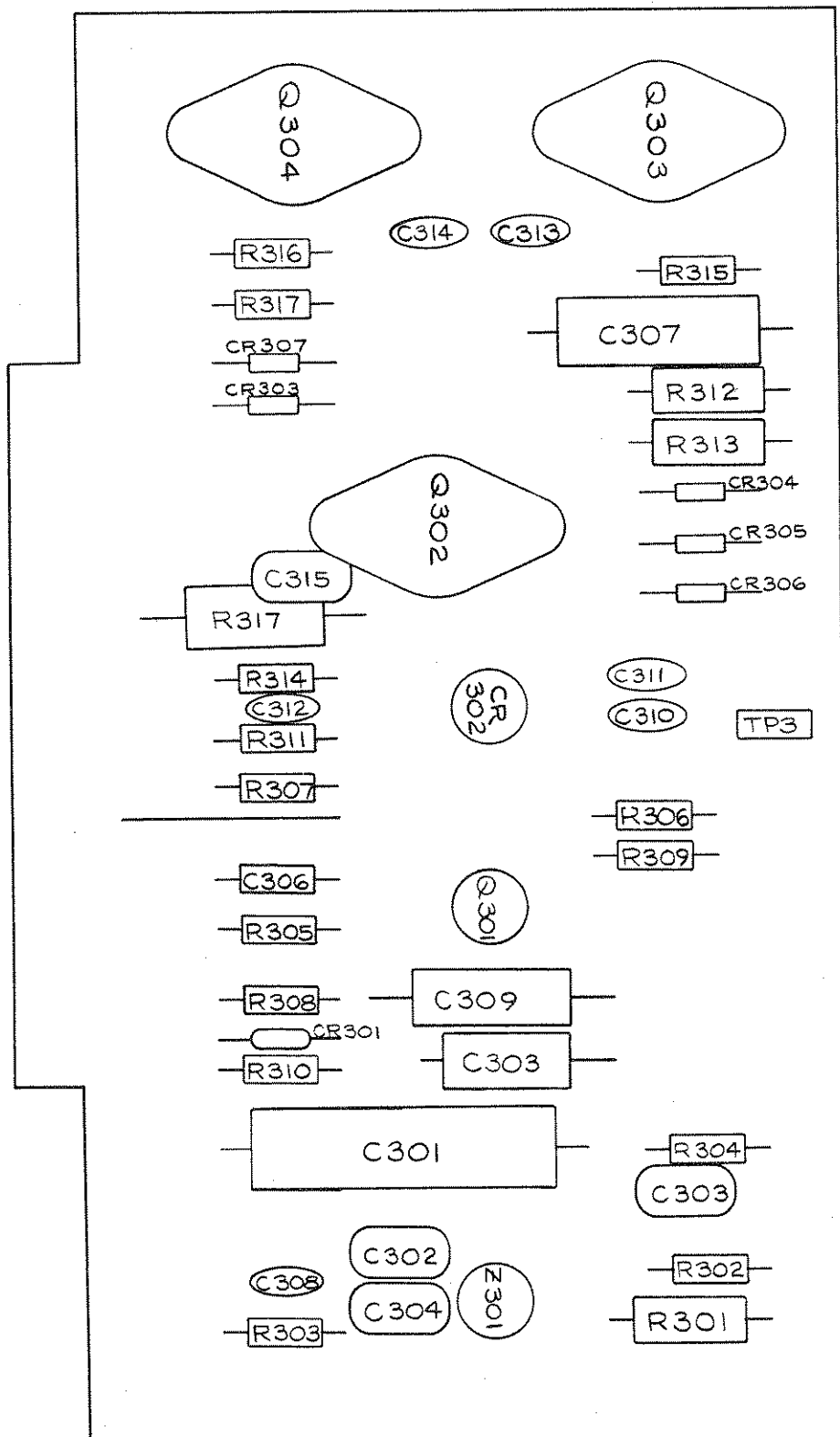

FIGURE 7-5. AMPLIFIER BOARD ASSEMBLY, MODEL 6004B

POWER SUPPLY BOARD 601-126-4X

SCHEMATIC DESIGNATION	VALUE	DESCRIPTION OR TYPE	RATING	MANUFACTURER		ELGAR PART NUMBER
				NAME	PART NUMBER	
C101,102	100 uF	Alum. Elec.	25V	Sprague	500D107G025DD7	824-107-51
C103,104	500 uF	Alum. Elec.	25V	Sprague	39D507G025HE4	824-507-52
C105	360 pF	Dip Mica	500V, 5%	ARCO	DM15-361J	820-361-05
C106	.01 uF	Disc	150V	Centralab	.DDM103	821-103-00
CR101		Zener		Motorola	MZ500-11	843-500-11
CR102,114,115, 120,121,122		Diode		Sylvania	1N914	844-914-XX
CR103-106,110-113, 116-119		Diode		ITT	1N4004	845-400-4X
CR108		Zener		Motorola	1N5352 <i>15V, 5%, 5W</i>	843-535-2X
CR109		Zener		Motorola	1N4756	843-475-6X
R101	6.8K	Carb Comp	1/2W, 5%	Speer	RC20GF682J	802-682-05
R102,113,114,118, 119,125,127,128	10K	Carb Comp	1/2W, 5%	Speer	RC20GF103J	802-103-05
R103	1.8K	Carb Comp	1/2W, 5%	Speer	RC20GF182J	802-182-05
R104	18K	Carb Comp	1/2W, 5%	Speer	RC20GF183J	802-183-05
R105,109,133	4.7K	Carb Comp	1/2W, 5%	Speer	RC20GF472J	802-472-05
R106,112	2.2K	Carb Comp	1/2W, 5%	Speer	RC20GF222J	802-222-05
R107	3.3K	Carb Comp	1/2W, 5%	Speer	RC20GF332J	802-332-05
R108,111	10 ohm	Carb Comp	2W, 5%	Speer	RC42GF100J	804-100-05
R110,120,121, 134,136	470 ohm	Carb Comp	1/2W, 5%	Speer	RC20GF471J	802-471-05
R115	470K	Carb Comp	1/2W, 5%	Speer	RC20GF474J	802-474-05
R116,117,126	15K	Carb Comp	1/2W, 5%	Speer	RC20GF153J	802-153-05
R122	221 ohm	Metal Film	1/8W, 1%	Dale	RN60C2210F	813-221-0F
R123	1.62K	Metal Film	1/8W, 1%	Dale	RN60C1621F	813-162-1F
R124	5.1K	Carb Comp	1/2W, 5%	Speer	RC20GF512J	802-512-05
R129	10K	Carb Comp	2W, 5%	Speer	RC42GF103J	804-103-05
R130,132	680 ohm	Carb Comp	2W, 5%	Speer	RC42GF681J	804-681-05
R131	1.5K	Carb Comp	1/2W, 5%	Speer	RC20GF152J	802-152-05
R135	4.7K	Carb Comp	2W, 5%	Speer	RC20GF472J	804-472-05
Q101,102		Transistor		RCA	40250V1	839-402-5V
Q103,104,105		Transistor		Fairchild	2N3567	835-356-7X
Q106		Transistor		RCA	2N3440	837-344-0X
Q107		Transistor		RCA	2N6211	842-621-1X

POWER SUPPLY BOARD (Continued)

SCHEMATIC DESIGNATION	VALUE	DESCRIPTION OR TYPE	RATING	MANUFACTURER		ELGAR PART NUMBER
				NAME	PART NUMBER	
Z101,102 Z103 Z104		Op Amp Comparator Quad Gate		Motorola National Motorola	MC1741CG LM311 MC668P	849-174-1X 849-LM3-11 849-668-PX
COMPONENT CHANGES FOR 6235B, 6236B, 6225B, 6245B, 6226B, 6246B POWER SUPPLY BOARD 601-276-4X						
R131	22K	Carb Comp	½W, 5%	Speer	RC20GF223J	802-223-05
R122	442 ohm	Metal Film	1/8W, 1%	Dale	RN60C4420F	813-442-0F
R130,132	2.2K	W.W.	10W, 5%	Dale	CW10-2.2K	808-222-05
R135	10K	Carb Comp	2W, 5%	Speer	RC42GF103J	804-103-05
CR109		Zener		Motorola	1N4764A	843-476-4A

## REFERENCE BOARD 601-121-4X Models 6006B, 6226B, 6246B, 6106B

SCHEMATIC DESIGNATION	VALUE	DESCRIPTION OR TYPE	RATING	MANUFACTURER		ELGAR PART NUMBER
				NAME	PART NUMBER	
C201,202	1.0 uF	Mylar	200V, 5%	IMB	ZA2C105J	822-105-53
C203	4.7K	Tantalum	35V	Sprague	196D475X0035JA1	823-475-61
C204	.15 uF	Mylar	200V	IMB	ZA2C154J	822-154-53
C205,209	2.0 uF	Polycarb	100V, 1%	IMB	BA1B205J	822-205-11
C206	.0082 uF	Polycarb	100V, 1%	IMB	BA1B822J	822-822-11
C207,208	2.0 uF	Mylar	200V, 5%	IMB	ZA2C205J	822-205-53
C210	.024 uF	Polycarb	100V, 1%	IMB	BA1B243J	822-243-11
C211	10 uF			IMB	JA2A106K	822-106-10
C212,213	.10 uF	Metal Film	200V, 10%	Sprague	192P10492	822-104-05
CR201,202,203,204,206,207		Diode		Sylvania	1N914	844-914-XX
CR205		Zener		Motorola	1N825	843-825-XX
R201,202,203,204	3.3K	Carb Comp	1/2W, 5%	Speer	RC20GF332J	802-332-05
R205	6.8K	Carb Comp	1/2W, 5%	Speer	RC20GF682J	802-682-05
R206,221	22K	Carb Comp	1/2W, 5%	Speer	RC20GF223J	802-223-05
R207,214	47K	Carb Comp	1/2W, 5%	Speer	RC20GF473J	802-473-05
R208	100K	Carb Comp	1/2W, 5%	Speer	RC20GF104J	802-104-05
R209	330	W.W.	2W, 5%	Sprague	240E3315	818-331-05
R210,212,219,226	10K	Carb Comp	1/2W, 5%	Speer	RC20GF103J	802-103-05
R211,216,220,236	4.7K	Carb Comp	1/2W, 5%	Speer	RC20GF472J	802-472-05
R213	15K	Carb Comp	1/2W, 5%	Speer	RC20GF153J	802-153-05
R215	150K	Carb Comp	1/2W, 5%	Speer	RC20GF154J	802-154-05
R218,228	10K	Potentiometer		Bourns	3059Y-10K	819-103-30
R222,223	18.2K	Metal Film	1/8W, 1%	Date	RN60C1822F	813-182-2F
R224	1.21K	Metal Film	1/8W, 1%	Date	RN60C1211F	813-121-1F
R225	1.5K	Carb Comp	1/2W, 5%	Speer	RC20GF152J	802-152-05
R227	17.8K	Metal Film	1/8W, 1%	Date	RN60C1782F	813-178-2F
R229,230,235	10K	Metal Film	1/8W, 1%	Date	RN60C1002F	813-100-2F
R231,232	20K	Metal Film	1/8W, 1%	Date	RN60C2002F	813-200-2F
R233,234	13.3K	Metal Film	1/8W, 1%	Date	RN60C1332F	813-133-2F
R237	FSV					
Q201-205		Transistor		Fairchild	2N3567	835-356-7X

REFERENCE BOARD (Continued)

SCHEMATIC DESIGNATION	VALUE	DESCRIPTION OR TYPE	RATING	MANUFACTURER		ELGAR PART NUMBER
				NAME	PART NUMBER	
Z201-206		Op Amp		Motorola	MC1741CG	849-174-1X
V201		LED Modulator		Aztec	12596/13710	848-125-96
COMPONENT CHANGES FOR 6005B, 6225B, 6245B, 6105B						
C205,209	2.4 uF	Polycarb	100V	IMB	BA1B245F	822-245-11
C206	.0098 uF	Polycarb	100V	IMB	BA1B982F	822-982-11
C210	.029 uF	Polycarb	100V	IMB	BA1B293F	822-293-11
COMPONENT CHANGES FOR 6004B						
C201,202	.15 uF	Mylar	200V	IMB	ZA2C154J	822-154-54
C205,209	.33 uF	Polycarb	100V	IMB	BA1B334F	822-334-11
C206	.00136 uF	Polycarb	100V	IMB	BA1B1361F	829-136-1F
C210	.004 uF	Polycarb	100V	IMB	BA1B402F	822-402-11
R222,223	16.5K	Metal Film	1/8W, 1%	Dale	RN60C1652F	813-165-2F
R227	20K	Metal Film	1/8W, 1%	Dale	RN60C2002F	813-200-2F
R233,234	12.1K	Metal Film	1/8W, 1%	Dale	RN60C1212F	813-121-2F

## AMPLIFIER BOARD 601-122-4X Models 6006B, 6005B, 6106B, 6105B

SCHEMATIC DESIGNATION	VALUE	DESCRIPTION OR TYPE	RATING	MANUFACTURER		ELGAR PART NUMBER
				NAME	PART NUMBER	
C301	10 uF	Polycarb	100V	IMB	SA9B106J	822-106-X0
C302	1000 pF	Dip Mica	500V, 5%	ARCO	DM15-102J	820-102-05
C303,310	470 pF	Dip Mica	500V, 5%	ARCO	DM15-471J	820-471-05
C306	.033 uF	Metal Film	200V, 10%	Sprague	192P33392	822-333-05
C307	50	Alum Elect.	50V	Sprague	500D506G0050DD7	824-506-71
C308	4.7 uF	Tantalum	35V	Sprague	196D475X0035JA1	823-475-61
C309	.1 uF	Metal Film	200V, 1%	Sprague	196P10492	822-104-05
CR301		Diode		Sylvania	1N914	844-914-XX
CR302		Triac		RCA	40766	842-407-66
CR303-307		Diode		EDI	1N4004	845-400-4X
R301	150K	Metal Film	½W, 5%	Dale	RN65D1503F	816-150-3F
R302	3.92K	Metal Film	1/8W, 1%	Dale	RN60C3921F	813-392-1F
R303	150K	Carb Comp	½W, 5%	Speer	RC20GF154J	802-154-05
R304	15K	Carb Comp	½W, 5%	Speer	RC20GF153J	802-153-05
R305,311,318	1.5K	Carb Comp	½W, 5%	Speer	RC20GF152J	802-152-05
R306	10K	Carb Comp	½W, 5%	Speer	RC20GF103J	802-103-05
R307	2.2K	Carb Comp	½W, 5%	Speer	RC20GF222J	802-222-05
R308	4.7K	Carb Comp	½W, 5%	Speer	RC20GF472J	802-472-05
R312,313	2.2K	Carb Comp	1W, 5%	Speer	RC32GF222J	803-222-05
R314	150 ohm	Carb Comp	½W, 5%	Speer	RC20GF151J	802-151-05
R315,317	100 ohm	Carb Comp	½W, 5%	Speer	RC20GF101J	802-101-05
R316	47 ohm	Carb Comp	½W, 5%	Speer	RC20GF470J	802-470-05
Q301		Transistor		RCA	2N5416	836-541-6X
Q302		Transistor		RCA	2N3585	839-358-5X
Q303		Transistor		RCA	2N3583	839-358-3X
Q304		Transistor		RCA	2N6211	842-621-1X
Z301		Op Amp		Motorola	MC1439G	849-143-9G



AMPLIFIER BOARD 601-125-4X Models 6226B, 6246B, 6225B, 6245B

SCHEMATIC DESIGNATION	VALUE	DESCRIPTION OR TYPE	RATING	MANUFACTURER		ELGAR PART NUMBER
				NAME	PART NUMBER	
C301	10 uF	Mylar	100V	IMB	SA9B106J	822-106-X0
C302,303	1000 pF	Dip Mica	500V	ARCO	DM15-102J	820-102-05
C311	250 pF	Dip Mica	500V, 5%	ARCO	DM15-251J	820-151-05
C309	.033 uF	Metal Film	200V, 10%	Sprague	192P33392	822-333-05
C310	.1 uF	Metal Film	200V, 10%	Sprague	192P10492	822-104-05
C307	25 uF	Alum. Elec	100V	Sprague	500D256F100DH7	824-256-91
R301	301K	Metal Film	1/2W, 1%	Dale	RN65D3013F	816-301-3F
R302	3.92K	Metal Film	1/8W, 1%	Dale	RN60C3921F	813-392-1F
R303	330K	Carb. Comp	1/2W, 5%	Speer	RC20GF334J	802-334-05
R306	10K	Carb. Comp	1/2W, 5%	Speer	RC20GF103J	802-103-05
R305,311,320	1.5K	Carb. Comp	1/2W, 5%	Speer	RC20GF152J	802-152-05
R307	2.2K	Carb. Comp	1/2W, 5%	Speer	RC20GF222J	802-222-05
R308	4.7K	Carb. Comp	1/2W, 5%	Speer	RC20GF472J	802-472-05
R310,315,316,317	470 ohm	Carb. Comp	1/2W, 5%	Speer	RC20GF471J	802-471-05
R312,313	4.7K	Carb. Comp	2W, 5%	Speer	RC32GF472J	803-472-05
R314	150 ohm	Carb. Comp	1/2W, 5%	Speer	RC20GF151J	802-151-05
R318,319	47K	Carb. Comp	2W, 5%	Speer	RC42GF473J	804-473-05
R304	15K	Carb. Comp	1/2W, 5%	Speer	RC20GF152J	802-153-05
CR301		Diode		Sylvania	1N914	844-914-XX
CR302		Triac		RCA	40766	839-407-66
CR303,307		Diode		Westing-house	1N4822	845-482-2X
CR304,305,306		Diode		EDI	1N4004	845-400-4X
O301,305		Transistor		RCA	2N5416	836-541-6X
O302		Transistor		Delco	DTS425	841-DT4-25
O303		Transistor		RCA	2N3583	839-358-3X
O304		Transistor		RCA	2N6211	842-621-1X
Z301		Op Amp		Motorola	MC1439G	849-143-9G

## AMPLIFIER BOARD 601-127-4X Model 6004B

SCHEMATIC DESIGNATION	VALUE	DESCRIPTION OR TYPE	RATING	MANUFACTURER		ELGAR PART NUMBER
				NAME	PART NUMBER	
C301	2 uF	Mylar	200V	IMB	ZA2C205J	802-205-53
C302	15 pF	Dip Mica	500V	ARCO	DM15-150J	820-150-05
C303	1000 pF	Dip Mica	500V	ARCO	DM15-103J	820-103-05
C304	150 pF	Dip Mica	500V	ARCO	DM15-151J	820-151-05
C305	.1 uF	Met Film	200V	Sprague	192P10492	822-104-05
C306	.022 uF	Met Film	200V	Sprague	193P22392	822-223-05
C307	50 uF	Alum Elec	50V	Sprague	500D506G050DP7	824-506-71
C308	4.7 uF	Tantalum	35V	Sprague	196D475X0035JAZ	823-475-61
C309	.68 uF	Polycarb	100V	IMB	BA2B684F	822-684-12
C310	2200 pF	Dip Mica	500V	ARCO	DM19-222J	820-222-05
C311	1500 pF	Dip Mica	500V	ARCO	DM19-152J	820-152-05
C312,313,314	.01 uF	Cer. Disc	500V	Centralab	DD102	821-103-00
C315	300 pF	Dip Mica	500V	ARCO	DM15-301J	820-301-05
R301	150K	Met Film	1/4W, 1%	Dale	RN65C1503F	816-150-3F
R302	3.92K	Met Film	1/8W, 1%	Dale	RN60C3921F	813-392-1F
R303	150K	Carb. Comp	1/2W, 5%	Speer	RC20GF154J	802-154-05
R304	10K	Carb. Comp	1/2W, 5%	Speer	RC20GF103J	802-103-05
R305	750 ohm	Carb. Comp	1/2W, 5%	Speer	RC20GF751J	802-751-05
R306,307	2.2K	Carb. Comp	1/2W, 5%	Speer	RC20GF222J	802-222-05
R308	4.7K	Carb. Comp	1/2W, 5%	Speer	RC20GF472J	802-472-05
R309,315,317	100 ohm	Carb. Comp	1/2W, 5%	Speer	RC20GF101J	802-101-05
R310	120 ohm	Carb. Comp	1/2W, 5%	Speer	RC20GF121J	802-121-05
R311	1.5K	Carb. Comp	1/2W, 5%	Speer	RC20GF152J	802-152-05
R312,313	2.2K	Carb. Comp	1W, 5%	Speer	RC32GF222J	803-222-05
R314	150 ohm	Carb. Comp	1/2W, 5%	Speer	RC20GF151J	802-151-05
R316	47 ohm	Carb. Comp	1/2W, 5%	Speer	RC20GF470J	802-470-05
R318	47K	Carb. Comp	2W, 5%	Speer	RC42GF473J	804-473-05
CR301		Diode		Sylvania	1N914	844-914-XX
CR302		Triac		RCA	40769	848-407-69
CR303-307		Rectifier		Motorola	1N4004	845-400-4X
Z301		Op Amp		National	LM301A	849-LM3-01
Q301		Transistor		RCA	2N5416	836-541-6X
Q302		Transistor		RCA	2N3585	839-358-5X
Q303		Transistor		RCA	2N3583	839-358-3X
Q304		Transistor		RCA	2N6211	842-621-1X

CHASSIS ASSEMBLY 6006B, 6105B, 6106B

SCHEMATIC DESIGNATION	VALUE	DESCRIPTION OR TYPE	RATING	MANUFACTURER		ELGAR PART NUMBER
				NAME	PART NUMBER	
B1		Fan		Pamotor	4500-MU2A-1	853-450-01
C1	20 uF	Oil Paper	236VAC	G.E.	49F6226	825-206-12
C2,3	5900 uF	Electrolytic	75V	G.E.	86F177M1	826-598-22
C4	2 uF	Oil Paper	600V	Sprague	CP53B1EF205K1	828-205-10
CB1		Circuit Breaker	15A, 250V	Airpax	UPG1-1-6-1-153	852-153-51
CR1-4		Diode Bridge		Motorola	MDA990-3	847-990-3X
CR5		Triac		RCA	2N5444	842-544-4X
DS1-2		Lamp		IEE	387	854-327-93
		Lens (red)		Eidema	RA220RT	854-220-21
		Lens (green)		Eidema	RA220GT	854-220-51
J1		Receptacle		Circle F	1515	856-151-53
M1		Meter	0-150V AC		MS2T	857-150-2T
M2		Meter	0-10A		MS2T	857-290-2T
R1,2	10K	Carb. Comp	2W, 5%	Speer	RC42GF103J	804-103-05
R3	390 ohm	W.W.	50W, 5%	Dale	RH50	810-391-05
S1		Tap Switch		Grayhill	19001-3	860-190-13
S2		Pushbutton Switch		Switchcraft	1006	860-100-6X
S3 (6105B,6106B)		DP Switch		Cutler-HAM	8381K27K	860-838-1K
R4	22.1K	Resistor	10%	Dale	RN60C2212F	813-221-2F
T1 (6606B)		ISO Transformer		Elgar		990-439-90
T1 (6105B,6106B)		ISO Transformer		Elgar		990-562-90
T2		Current Xfmr.		Elgar		990-191-91
K1 (6105B,6106B)		Relay		Magnacraft	W88AX-12	861-88X-12
HEATSINKS						
Upper						
CR401		Diode		Motorola	1N3210	845-321-0X
Q401-405		Transistor		RCA	2N6259	841-625-9X
R401	5.6 ohm	Wire Wound	5W, 5%	Dale	CW5-5.6	807-5R6-05
R402-405	.68 ohm	Wire Wound	5W, 5%	Dale	CW5-.68	807-R68-05
S401		Thermostat		Elmwood	2450-21-272	861-340-0X
Lower						
CR501		Diode		Motorola	1N3210	845-321-0X
Q501-505		Transistor		RCA	2N6259	841-625-9X
R501	5.6 ohm	Wire Wound	5W, 5%	Dale	CW5-5.6	807-5R6-05
R502-505	.68 ohm	Wire Wound	5W, 5%	Dale	CW5-.68	807-R68-05

CHASSIS ASSEMBLY Models 6226B, 6246B, 6225B, 6245B

SCHEMATIC DESIGNATION	VALUE	DESCRIPTION OR TYPE	RATING	MANUFACTURER		ELGAR PART NUMBER
				NAME	PART NUMBER	
B1		Fan		Pamotor	4500	853-450-01
C1	5 uF	Oil Paper	236VAC			825-505-11
C2,C3	1900	Electrolytic	150V	G.E.	KKX23P505Q	826-218-31
C4	10 uF	Oil Paper	236V		86F195M1	825-106-1X
C5,6,7,8	.0056 uF	Cer. Disc	500V, 10%	Erie	KKL23P106Q	821-562-00
C9	1 uF	Oil Paper	600V	Sprague	811-000-X5FO-562K	828-105-10
CB1		Circuit Breaker	7.5A	Airpax	CP53B1EF105K1	852-752-51
CR1,2,3,4		Diode Bridge	400V	Motorola	UPG1-1-6-1-752	847-990-5X
CR5		Triac		RCA	MDA990-5	842-544-4X
DS1,2		Lamp		IEE	2N5444	854-327-93
J1		Lens (red)		Eidema	387	854-220-21
M1		Lens (green)		Eidema	RA220RT	854-220-51
M2		Receptacle		G.E.	RA220GT	856-475-X6
R1,R2	10K	Meter	0-300V		4750	857-300-2T
R3	750 ohm	Meter	0-5 Amp		MS2T	857-328-2T
R4,5,6,7	200 ohm	Carb. Comp	2W, 5%	Speer	RC42GF103J	804-103-05
R8	2.4 ohm	Wire Wound	50W, 5%	Dale	RH50 750R	810-751-05
S1		Wire Wound	25W, 5%	Dale	RH25 200R	809-201-05
S2		Wire Wound	10W, 5%	Dale	CW10 2.4R	808-2R4-05
T1		Tap Switch		Grayhill	19001-3	860-190-13
T2		Pushbutton Switch		Switchcraft	1006	860-100-6X
HEATSINK - UPPER		ISO Transformer		Elgar		990-327-90
CR401		Current Xfmr.		Elgar		990-191-91
Q401-406		Diode		Motorola	1N3211	845-321-1X
R401	5.6 ohm	Transistor	5W, 5%	RCA	2N6259	841-625-9X
R402	1K	Wire Wound	10W, 5%	Dale	CW5 5.6R	807-5R6-05
R403,404	.68 ohm	Wire Wound	5W, 5%	Dale	CW10 1KR	808-102-05
HEATSINK - LOWER		Wire Wound		Dale	CW5 .68R	807-R68-05
CR501		Diode		Motorola	1N3211	845-321-1X
Q501-506		Transistor		RCA	2N6259	841-625-9X
R501	5.6 ohm	Wire Wound	5W, 5%	Dale	CW5 5.6R	807-5R6-05
R502	1K	Wire Wound	10W, 5%	Dale	CW10 1KR	808-102-05
R503,504	.68 ohm	Wire Wound	5W, 5%	Dale	CW5 .68R	807-R68-05
S501		Thermostat		Elmwood	2450-21-272	861-340-0X

CHASSIS ASSEMBLY Model 6004B

SCHEMATIC DESIGNATION	VALUE	DESCRIPTION OR TYPE	RATING	MANUFACTURER		ELGAR PART NUMBER
				NAME	PART NUMBER	
B1		Fan		IMC	BC2206F-0-1	853-220-01
C1	75 uF	Oil Paper	236V	Corn.Dub.	KKL23P755Q	825-755-11
C2,3	5900 uF	Electrolytic	75V	G.E.	86F177M1	826-598-22
C5	.22 uF		600V		6PS-P22	822-224-06
CB1	250VAC	Circuit Breaker	15A	Airpax	UPG1-1-6-1-153	852-153-51
CR1,2,3,4		Diode Bridge	200V	Motorola	MDA990-3	847-990-3X
CR5		Triac		RCA	40793	842-407-93
DS1,2		Lamp	28V	IEE	387	854-327-93
J1		Lens (red)		Eidema	RA220RT	854-220-21
M1		Lens (green)		Eidema	RA220GT	854-220-51
M2		Receptacle		Circle F	1515	856-151-53
R1,R2	10K	Meter	0-150VAC		MS2T	857-150-2T
R3	390 ohm	Meter	0-10 Amp	Speer	MS2T	857-290-2T
S1		Carb. Comp	2W, 5%	Dale	RC42GF103J	804-103-05
S2		Wire Wound	50W, 5%	Grayhill	RH50	810-391-05
T1		Tap Switch		Switchcraft	19001-3	860-190-13
T2		Pushbutton Switch		Elgar	1006	860-100-6X
HEATSINKS		ISO Transformer		Elgar		990-374-90
Upper		Current Xfmr		Elgar		990-191-91
CR401		Diode		Motorola	1N3210	845-321-0X
Q401-405		Transistor		RCA	2N6259	841-625-9X
R401	5.6 ohm	Wire Wound	5W, 5%	Dale	CW5 5.6R	807-5R6-05
R402-405	.68 ohm	Wire Wound	5W, 5%	Dale	CW5 .68R	807-R68-05
S401		Thermostat		Elmwood	2450-21-272	861-340-0X
Lower						
CR501		Diode		Motorola	1N3210	845-321-0X
Q501-505		Transistor		RCA	2N6259	841-625-9X
R501	5.6 ohm	Wire Wound	5W, 5%	Dale	CW5 5.6R	807-5R6-05
R502-505	.68 ohm	Wire Wound	5W, 5%	Dale	CW5 .68R	807-R68-05

0  
1  
2  
3  
4  
5  
6  
7  
8  
9  
A  
B  
C  
D  
E  
F  
G  
H  
I  
J  
K  
L  
M  
N  
O  
P  
Q  
R  
S  
T  
U  
V  
W  
X  
Y  
Z