

INSTRUCTION MANUAL

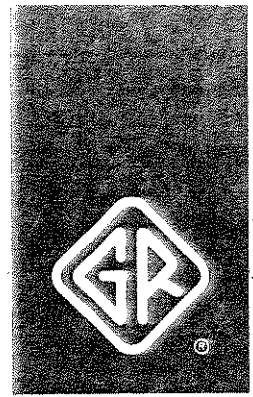

RAYCOMM CAL LAB ESD

TYPE 1615-A

CAPACITANCE BRIDGE

TYPE 1620-A, -AP

CAPACITANCE MEASURING

ASSEMBLY

GENERAL RADIO COMPANY

D

1615-A/1620-A, -AP

1615-A 1620-A

Type 1615-A CAPACITANCE BRIDGE

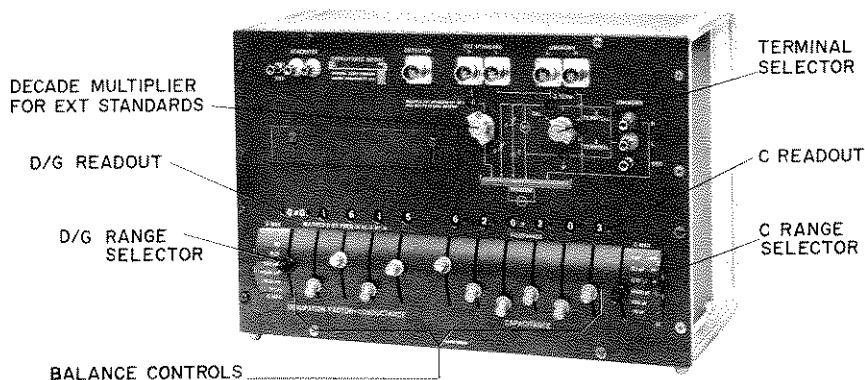
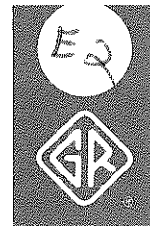

PREPARATION FOR USE

The Type 1615-A Capacitance Bridge requires an external generator and detector. Connect the generator (General Radio Type 1311-A Audio Oscillator or equivalent) to the GENERATOR terminals; input to bridge should not exceed 30 v/kc. Thus, at 60 cps, input should not exceed 2 volts, in order to avoid waveform distortion. Use a shielded patch cord, such as the General Radio Type 274-NL. Remove the shorting link from the lower OUTPUT binding post on the Type 1311-A before attaching the patch cord.

Connect a tuned detector (General Radio Type 1232-A Tuned Amplifier and Null Detector or equivalent) to the DETECTOR connector; a 1- μ v or better sensitivity is required for measurements in the 10- μ pf range. Use a double-shielded coaxial patch cord, such as General Radio Type 874-R22A. If a detector other than the Type 1232-A is used, there is a full line of General Radio coaxial adaptors available which will permit use of the Type 874-R22A patch cord.

Make sure that all connections to generator, detector, unknown capacitor, and any standard capacitors involved, are solidly made, especially with regard to shielded leads. Observe that all lever-type controls on the Type 1615-A are fully engaged in detent positions.

DIGITAL READOUT

Digital readouts appear in windows directly above all balance controls, as do red decimal-point indicators, automatically positioned by range-switch settings.

Direct six-digit CAPACITANCE readouts in picofarads (with appropriate decimal point) are provided in ranges determined by the position of the C MAX switch.

DISSIPATION FACTOR readouts of four digits in three ranges, dependent on D MAX switch settings, are available with automatically positioned decimal. Readouts should be multiplied by frequency in kilocycles.

Direct four-digit readouts of CONDUCTANCE measurements, in μ mhos, are provided in four ranges determined by setting of the G MAX switch, which also places decimal point. However, in the three highest capacitance ranges, this readout must be multiplied by the (red) M factor corresponding to the C MAX setting.

All readouts offer 0 through 9 indications plus X, which indicates 10. Thus, a reading of 348X12 is equivalent to 349012.

In addition, the CAPACITANCE readout has a -1 position, which indicates that the corresponding unit of capacitance has been placed across the UNKNOWN arm of the bridge and is to be subtracted from the bridge reading. A reading of 348(-1)12 is equivalent to 348012 - 000100 = 347912.

CONDUCTANCE values add loss to the standard side of the bridge in +0.1 and +0.01 positions and to the unknown side in -0.1 and -0.01 positions. A negative G means the conductance of the unknown is the conductance of the internal and external standards minus the bridge G reading.

Decimal readouts in the MULTIPLY BY window indicate the 11 steps by which the capacitor connected to the EXT STANDARD connectors can be varied.

EQUIPMENT TURN-ON

The Type 1615-A Capacitance Bridge is a purely passive instrument and has no primary power or turn-on requirements. Apply power to the generator and detector used, and allow for warm-up time, as required.

NOTE: Procedures which follow assume the use of the Type 1311-A as the generator and the Type 1232-A as the detector at some frequency between 50 cps and 10 kc. For operational details, refer to the operating instructions for the respective instruments.

GENERATOR. To adjust the Type 1311-A:

- > a. Set FREQUENCY selector to desired frequency.
- > b. Set MAXIMUM OUTPUT selector and OUTPUT control for a voltage level not greater than 30 volts per kilocycle.

DETECTOR. To adjust the Type 1232-A:

- > a. Adjust FILTER FREQUENCY switch to approximate frequency of generator.
- > b. Rotate FILTER TUNING control to peak meter.
- > c. Set METER switch to LOG position.
- > d. Adjust GAIN control for midscale indication.

EQUIPMENT SELF-CHECK

As a check of the proper operation of bridge, generator, and detector, a bridge balance can be made at any time with no external capacitors connected. Proceed as follows:

- > a. Set terminal switch to CAL (all UNKNOWN L connectors are thereby removed from the bridge circuit).
- > b. Set MULTIPLY BY switch to 0.
- > c. Set C MAX to any position.
- > d. Set D MAX switch to 0.01.
- > e. Null should occur with DISSIPATION FACTOR balance controls at 0000 and CAPACITANCE balance controls at 000000 (position of decimal point varies with C MAX settings). Detector deflection should increase if any CAPACITANCE control is moved from the 0 position.

BRIDGE BALANCE PROCEDURES

The following procedures apply for all modes of operation. Procedures for terminal selection and attach-

ment of capacitor under test, which appear in subsequent paragraphs, are here assumed to have been completed.

- > a. Move C MAX lever to a setting slightly in excess of approximate value of capacitor being measured, or to 1 μ f, if value is not known.
- > b. Set D MAX lever switch to 0.01 and set all DISSIPATION FACTOR levers to 0.
- > c. Position left-most CAPACITANCE lever for minimum deflection on detector meter.
- > d. To refine balance, position remaining CAPACITANCE levers, beginning at left and proceeding to right, until no further improvement occurs.

NOTE: To improve sharpness of balance indication, increase GAIN on detector, but restrict meter to lower half of scale.

- > e. Manipulate DISSIPATION FACTOR switches, starting with right-most, to refine balance further.
- > f. Alternately manipulate first CAPACITANCE and then DISSIPATION FACTOR levers until final null is accomplished. An increase in D MAX may be required.

NOTE: If no null can be achieved in D MAX positions, try G MAX settings (same lever switch).

- > g. Observe direct CAPACITANCE readout in picofarads in the six digital windows above lever switches, noting placement of red decimal.
- > h. Observe direct DISSIPATION FACTOR reading, if appropriate, from digital windows above switches, noting placement of decimal point. At 1 kc, dissipation factor is as indicated; otherwise, multiply by frequency in kc.
- > i. If appropriate, observe CONDUCTANCE in μ mhos, reading from digital windows above switches. Multiply reading by M factor (red engraving on C MAX dial) to calculate final value.

DIRECT CAPACITANCE MEASUREMENT

For direct measurement, no connection to the EXT STANDARD terminals is required; see below for use with an external standard. Whenever the EXT STANDARD terminals are not used:

- > a. Install Type 874-WO coaxial termination on EXT STANDARD L connector to complete shielding.
- > b. Set MULTIPLY BY switch to 0.

THREE-TERMINAL SHIELDED COAXIAL CONNECTIONS

To measure direct or three-terminal capacitance of capacitors with coaxial terminals (GR Types 1403, 1422), or of capacitors at the end of cables where only the direct capacitance between the H and L center conductors of the terminals is measured, and all capacitance from H and from L to outer conductor or GND is excluded:

- > a. Set terminal switch to 3 TERM to connect bridge to coaxial unknown terminals.
- > b. Connect capacitor under test to H and L coaxial terminals. The lead connected to the L terminal (high-impedance side of detector) must always be shielded. Use Type 874-R22A patch cord with appropriate Type 874 coaxial adaptor, if required.
- > c. Balance bridge as indicated previously.

THREE-TERMINAL UNSHIELDED BINDING-POST CONNECTIONS

To measure direct or three-terminal capacitance of capacitors with unshielded plug or jack terminals (GR Type 1409) or with leads, where only the direct capacitance between the H and L terminals is measured, and all capacitance from H and from L to GND, case, or external ground is excluded:

- > a. Set terminal switch to 3 TERMINAL to connect bridge to three binding-post UNKNOWN terminals.

- > b. Connect capacitor under test to the H and L binding posts. Connect shields or case to GND post. If leads are used, shield lead to the L terminal (high-impedance side of detector).
- > c. Balance bridge as indicated previously.
- > d. To determine capacitance added by the capacitor, remove capacitor from terminals or leads, measure the capacitance of the open terminals (about 0.2 pf) or open leads, and subtract from the total capacitance measured in step c.

NOTE: High capacitance or conductance from the H terminal to GND loads the transformer and may produce small capacitance error. High capacitance from the L terminal to GND shunts the detector and may reduce the sensitivity.

TWO-TERMINAL BINDING-POST CONNECTIONS

To measure the capacitance of capacitors with unshielded terminals (GR Types 1409, 1401) or leads with one terminal grounded, where all the capacitance from the H terminal to L and GND terminals, to bridge case, and to external ground is measured:

- > a. Set terminal switch to 2 TERMINAL to connect bridge to three binding-post UNKNOWN terminals. The L terminal is connected to GND.
- > b. Connect the capacitor under test to the H and L (or GND) binding posts with the case, low, or G side of the capacitor connected to the L (or GND) post.
- > c. Connect a bridge GND terminal to an external ground to eliminate changes in bridge balance produced by motion of operator's hands near the balance controls (not near the UNKNOWN terminals).
- > d. Balance the bridge as indicated previously.
- > e. To determine the capacitance added by the capacitor, remove the capacitor from terminals or leads, measure the capacitance of the open terminals (about 1.4 pf) or open leads, and subtract from the total capacitance measured in step d.

USE WITH EXTERNAL STANDARDS

To extend the accuracy of the bridge by adding to the internal capacitors an external standard capacitor of higher accuracy, or to extend the range and resolution by adding an external capacitor of larger or smaller capacitance than the internal standards:

- > a. Set the terminal switch to 3 TERM. (For procedure when binding posts are used, see complete Operating Instructions.)
- > b. Connect a three-terminal external standard capacitor to the coaxial H and L EXT STANDARD terminals. Shield at least the lead to the L terminal.
- > c. Connect capacitor under test as in procedure above for three-terminal shielded coaxial connections.
- > d. Set MULTIPLY BY switch to appropriate position from 1 to 0.1, or use this switch as a seventh capacitance control to balance the bridge.
- > e. Balance bridge with CAPACITANCE controls and with CONDUCTANCE controls. DISSIPATION FACTOR controls seldom have adequate range when external standard is used.
- > f. Determine measured value of capacitor on UNKNOWN terminals by adding to the six-figure bridge CAPACITANCE readout the capacitance of the external standard multiplied by the readout in the window of the MULTIPLY EXT STANDARD BY switch and by the factor M engraved in red to the right of the C MAX control knob. Example: Ext standard C = 1000.0000 pf. C MAX set at 100 pf. Bridge reads 31.4159 pf. MULTIPLY EXT STANDARD BY switch set at 0.5. Capacitance of unknown is $1000.0000 \times 0.5 \times (M=1) = 500.000$ plus 31.4159 equals 531.4159.

G E N E R A L R A D I O C O M P A N Y

WEST CONCORD, MASSACHUSETTS, USA

INSTRUCTION MANUAL

TYPE 1615-A
CAPACITANCE BRIDGE
TYPE 1620-A, -AP
CAPACITANCE MEASURING
ASSEMBLY

Form 1615-0100-D
ID 887
March, 1968

NOTE: The abbreviation for cycles per second in this manual or on the instrument may be cps, c/s, or Hz.

NOTE: This instrument is equipped with our new snap-on knob for added convenience and safety. Refer to the Service Section for details.

Copyright by General Radio Company
October, 1963

GENERAL RADIO COMPANY
WEST CONCORD, MASSACHUSETTS, USA

TABLE OF CONTENTS

Section 1	INTRODUCTION	1
1.1	Purpose	1
1.2	Description	1
1.3	Controls and Connectors	2
Section 2	INSTALLATION	7
2.1	General	7
2.2	Type 1620-A Installation	7
2.3	Assembly of Type 1620-A	8
2.4	Equipment Substitutions	8
Section 3	OPERATING PROCEDURES	10
3.1	General	10
3.2	Preparation For Use	10
3.3	Equipment Turn-On	10
3.4	Equipment Self-Check	10
3.5	Digital Readout on Type 1615-A	11
3.6	Bridge Balance Procedures	12
3.7	Capacitance Balance Controls	12
3.8	Loss Balance Controls	16
3.9	Errors From Transformer Impedances and Other Sources	18
Section 4	THEORY OF OPERATION	25
4.1	Introduction	25
4.2	Properties of Capacitors	25
4.3	Capacitance Measurements	28
4.4	The Type 1615-A Capacitance Bridge	30
4.5	Type 1615-A Accuracy	35
4.6	Controls and Indicators	36
4.7	Connection of Unknown	37
4.8	External Standards	38
Section 5	SPECIAL MEASUREMENTS	39
5.1	General	39
5.2	Use With External Standards	39
5.3	Calibration of Two-Terminal Capacitors at Ends of Cables	44
5.4	Application of DC Bias to Unknown	46
5.5	Generator and Detector Reversed	47
Section 6	CALIBRATION AND ADJUSTMENT	49
6.1	General	49
6.2	Self-Check Procedures	49
6.3	Capacitor Calibration-Adjustment	51
6.4	Conductance Calibration	54
6.5	Dissipation-Factor Calibration	56
6.6	Decade Resistor Calibration	60
6.7	Test and Adjustment of Bridge Zero	61
Section 7	SERVICE AND MAINTENANCE	65
7.1	Warranty	65
7.2	Service	65
7.3	Service Instructions	65
7.4	Minimum Performance Standards	65
7.5	Trouble Analysis	65
7.6	Disassembly	68
7.7	Control-Indicator Alignment	70
7.8	Lever-Switch Maintenance	72
7.9	Decade-Resistor Calibration	73
7.10	Adjustment of D MAX Ranges	73
7.11	Knob Removal	74
	PARTS LIST	76
	SCHEMATIC	77
	APPENDIX	78

SPECIFICATIONS

FOR 1620-A CAPACITANCE MEASURING ASSEMBLY

(see 1615 for performance specifications)

Frequency: 50, 60, 100, 120, 200, 400, 500, 1000, 2000, 5000, and 10,000 Hz. For use below 100 Hz, 1620-AP (with preamplifier) should be used for resolution beyond 0.01% or 0.01 pF.

Generator: 1311-A Oscillator.

Detector: 1232-A Tuned Oscillator and Null Detector. 1232-P2 Preamplifier added in 1620-AP.

Power Required: 105 to 125 or 210 to 250 V, 50 to 400 Hz, 22 W for oscillator. Null detector and preamplifier operate from internal battery.

Mounting: Assembled in cabinet.

Weight: Net, 59 lb (27 kg); shipping, 96 lb (44 kg).

Catalog Number	Description
1620-9701	Capacitance-Measuring Assembly 1620-A
1620-9829	1620-AP, with 1232-P2 detector preamplifier

FOR 1615-A CAPACITANCE BRIDGE

RANGES OF MEASUREMENT

Capacitance, 10 aF to 1.11110 μF (10^{-17} to 10^{-6} farad) in 6 ranges, direct-reading, 6-figure resolution; least count 10^{-17} F (10 aF). With Range-Extension Capacitor, upper limit is 11.11110 μF .

Dissipation Factor, D, At 1 kHz, 0.000001 to 1, 4-figure resolution; least count, 0.000001; range varies directly with frequency.

Conductance, G, 10^{-6} μS to 100 μS , 2 ranges +, 2 ranges -, 4-figure resolution, least count 10^{-6} μS independent of frequency; range varies with C range.

FREQUENCY: Approx 50 Hz to 10 kHz. Useful with reduced accuracy to 100 kHz. Below 100 Hz, resolution beyond 0.01% or 0.01 pF requires preamplifier or special detector.

GENERAL

Standards: 1000, 100, 10, 1, 0.1, 0.01, 0.001, 0.0001 pF. Temperature coefficient of capacitance is less than 5 ppm/°C for the 1000-, 100-, and 10-pF standards, slightly greater for the smaller units.

Generator: Type 1310-A or 1311-A oscillator recommended. Max safe generator voltage $30 \times f_{\text{kHz}}$ volts, 300 V max. If generator and detector connections are interchanged, 150 to 500 V can be applied, depending on switch settings.

Detector: Type 1232-A Tuned Amplifier and Null Detector recommended. For increased sensitivity needed to measure low-loss small capacitors (on lowest C and D ranges simultaneously) at frequencies below 1 kHz, use 1232-AP.

Accessories Supplied: 874-WO Open-Circuit Termination, 874-R22A Patch Cord, 274-NL Patch Cord.

Accessories Available: Type 1615-P1 Range-Extension Capacitor.

ACCURACY

At 1 kHz, $\pm(0.01\% + 0.00003 \text{ pF})$. At higher frequencies and with high capacitance, additional error is $[\pm 3 \times 10^{-5}\% + 2 \times 10^{-3}\% (C_{\text{MF}} \pm 3 \times 10^{-7} \text{ pF})] \times f_{\text{kHz}}$. At lower frequencies and with low capacitance, accuracy may be limited by bridge sensitivity. Comparison, accuracy, unknown to external standard, 1 ppm.

$\pm[0.1\% \text{ of measured value} + 1 \times 10^{-5} (1 + f_{\text{kHz}} + 5 f_{\text{kHz}} C_{\text{MF}})]$

$\pm[1\% \text{ of measured value} + 1 \times 10^{-5} \mu\text{S} + 6 \times 10^{-2} f_{\text{kHz}} C_{\text{MF}} \times (1 + f_{\text{kHz}} + 5 f_{\text{kHz}} C_{\text{MF}}) \mu\text{S}]$

1615-P2 Coaxial Adaptor converts 2-terminal binding-post connection on 1615 bridge to GR900 Precision Coaxial Connector for highly repeatable connections; enables measurements with adaptor to be direct-reading by compensating for terminal capacitance.

Mounting: Rack-Bench Cabinet.

Dimensions (width x height x depth): Bench model, 19 x 12 $\frac{3}{4}$ x 10 $\frac{1}{2}$ in. (485 x 325 x 270 mm); rack model, 19 x 12 $\frac{1}{4}$ x 8 $\frac{1}{2}$ in. (485 x 315 x 220 mm); 1615-P1, 3-1/16 in. dia. x 4 $\frac{7}{8}$ in. (78 x 125 mm).

Weight: Net, 38 $\frac{1}{2}$ lb (17.5 kg); shipping, 58 lb (27 kg).

Catalog Number	Description
1615-9801	1615-A Capacitance Bridge Bench Model
1615-9811	Rack Model
1615-9601	1615-P1 Range-Extension Capacitor
1615-9602	1615-P2 Coaxial Adaptor, GR900 to binding posts

General Radio Experimenter references: Vol 36 Nos. 8 & 9 August-September 1962
Vol 37 No. 8 August 1963
Vol 38 No. 2 February 1964

U. S. Patent No. 2,548,457.



TYPE 1615-A CAPACITANCE BRIDGE

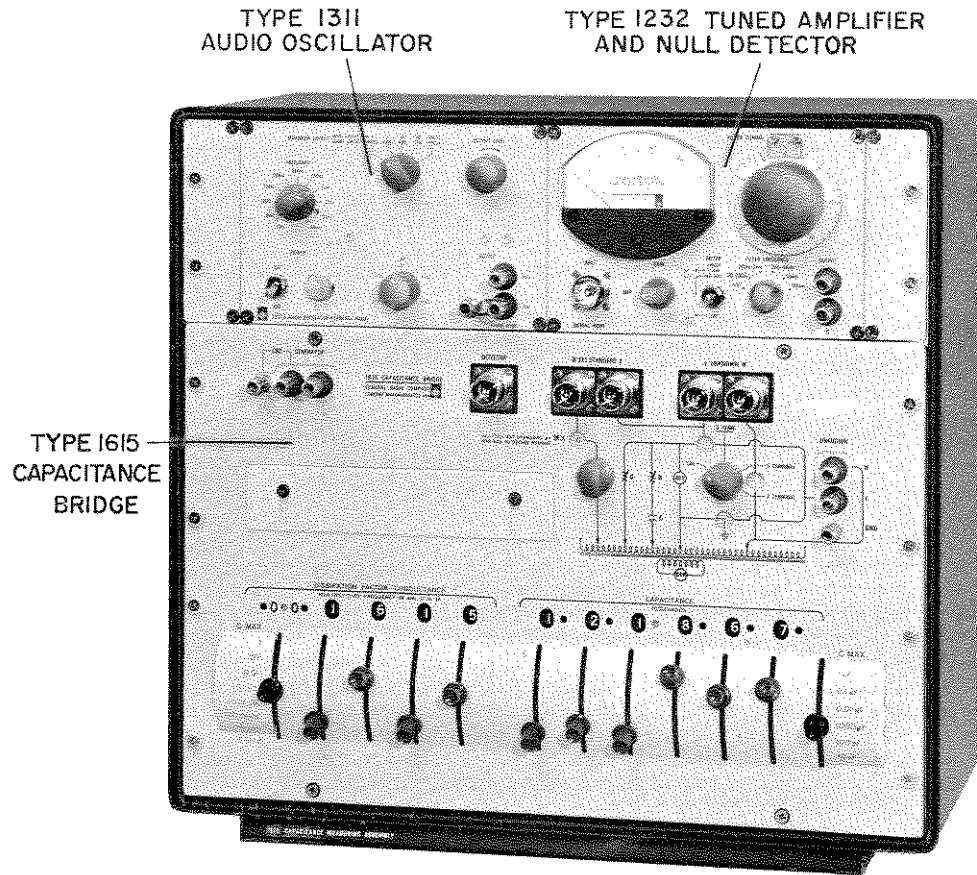

Figure 1-1. Type 1620-A Capacitance Measuring Assembly.

SECTION I

INTRODUCTION

1.1 PURPOSE.

The Type 1620-A Capacitance-Measuring Assembly (Figure 1-1) is designed for the precise measurement of capacitors and capacitance standards. In the standards laboratory, its high resolution for capacitance and dissipation factor make it well-suited for capacitance standards measurements. Its in-line readout system minimizes reading errors and permits rapid operation.

It can measure both 3-terminal and 2-terminal capacitors. Because transformer ratio arms are used in the bridge, 3-terminal measurements can be made accurately, even in the presence of large capacitances to ground. For instance, a ground capacitance of 1 μf produces an error of only 0.01% in the measurement of 1000-pf capacitor. This feature makes the assembly very useful for *in situ* measurements of circuit capacitances.

A wide range of capacitances can be measured, extending from a lower limit of 10 μpf (10^{-5} pf) to a maximum of 1 μf , with internal standards. With external standards, 1000 μf is the upper limit.

Since an important use of this bridge is the comparison of capacitance standards, an extra set of coaxial terminals is provided on the bridge to which a reference standard can be connected. The standard under test is then connected to the UNKNOWN terminal, and the internal standards used to complete the balance. If the difference between the unknown and reference standard is small, the accuracy of the measurement is equal to the

accuracy of calibration of the reference standard. In this measurement, the internal bridge standards can be compared with equal ease to either the unknown or reference standard; hence, both positive and negative differences can be measured.

1.2 DESCRIPTION.

1.2.1 GENERAL. The Type 1620-A Capacitance-Measuring Assembly consists of the Type 1615-A Capacitance Bridge with the Type 1311-A Audio Oscillator and the Type 1232-A Tuned Amplifier and Null Detector, a complete system for the precise measurement of capacitance.

Oscillator and detector are mounted side by side as shown in Figure 1-1 atop the bridge. The end frames are bolted together to make a rigid assembly obviating any requirement for the use of a relay rack. Connecting cables are supplied. An elementary system diagram is given in Figure 1-2.

1.2.2 BRIDGE CIRCUIT. The ratio arms of the bridge are transformer windings, tapped on the standard side in decimal steps from 0.1 to 1, and on the unknown side in decade steps from 1 to 0.001. Eight separate, fixed-capacitance standards are used, whose values range in decade steps from 0.0001 pf to 1000 pf. This combination of internal standards and transformer ratios makes possible the wide measurement range of $10^9:1$.



TYPE 1615-A CAPACITANCE BRIDGE

The loss component is read as either dissipation factor or conductance, the former being mandatory when D is greater than about 0.01. G must be used when external standards are used or internal standards are compared.

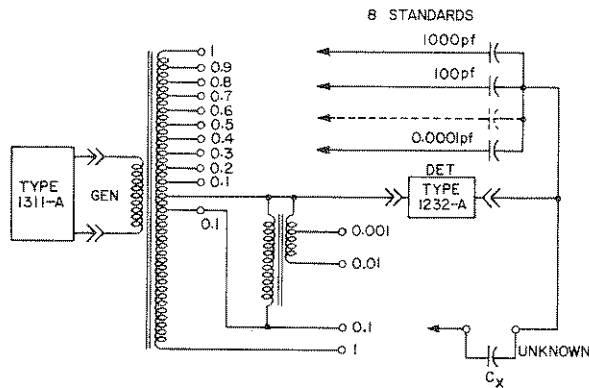

Figure 1-2. Type 1620-A Capacitance Measuring Assembly.

1.2.3 STANDARDS. Capacitance standards utilize plates fabricated from Invar steel for high dimensional stability and are hermetically sealed to eliminate changes in value resulting from changes in atmospheric pressure and humidity.

Provision is made for front panel adjustment of the internal capacitance standards in terms of the accurate transformer ratio or of external standards.

1.2.4 GENERATOR. The Type 1311-A Audio Oscillator is an ac powered, all-transistor instrument for use in bridge-measurement work requiring a compact source of distortion-free, audio-frequency, sine-wave signals. It

provides at least 1.0 watt output power into a wide range of load impedances at eleven frequencies between 50 and 10,000 cps with an accuracy of $\pm 1\%$. Other features include the ability to drive any impedance without clipping. For bridge measurements the shielded secondary winding on the output transformer permits the oscillator to be used as a floating source, thus minimizing or eliminating circulating ground currents.

1.2.5 NULL DETECTOR. The Type 1232-A Tuned Amplifier and Null Detector is a versatile instrument designed primarily as a bridge detector. It consists of a sensitive, low-noise preamplifier, a frequency-selective stage (feedback amplifier and null network), an amplifier-compressor stage, and a meter-rectifier circuit. The total gain capability of the amplifier is about 120 db. Full-scale meter sensitivity is 1 microvolt, or better, over most of a frequency range which is continuously tunable from 20 cps to 20 kc, with additional fixed-tuned frequencies of 50 kc and 100 kc. This null detector permits balances to a resolution of 1 part in 10^6 .

1.3 CONTROLS AND CONNECTORS.

1.3.1 BRIDGE CONTROLS (See Figure 1-3). Lever-type switches are used for both capacitance and conductance-dissipation-factor balances. In addition to the usual decades steps (0.1.....0.9, X), each capacitance switch has a -1 position, which greatly facilitates the balancing procedure. The capacitance readout is in picofarads, with the decimal point automatically indicated in red.

Table 1-1 lists and describes all front-panel controls and indicators found on the Type 1615-A bridge.

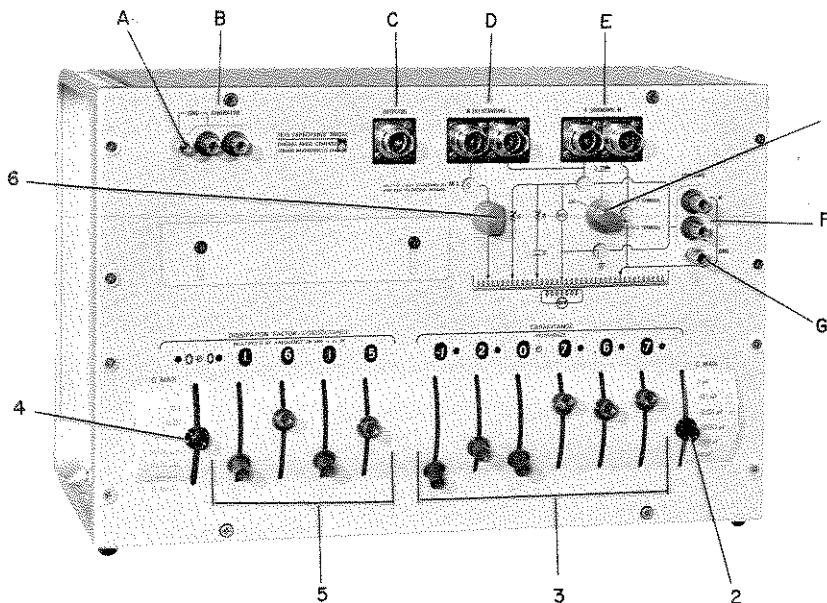

Figure 1-3. Type 1615 Capacitance Bridge controls and indicators. (Refer to Tables 1-1 and 1-2.)

**TABLE 1-1
CONTROLS AND INDICATORS - TYPE 1615**

NAME	REF	TYPE	FUNCTION	RELATED INDICATOR
Terminal Selector (Gray Pointer Knob)	S113 Fig. 1-3 (1)	4-position rotary switch	Used to place bridge in desired operating mode, i.e. calibration, 3-terminal shielded, 3-terminal unshielded and 2-terminal.	Fixed simplified schematic engraved on front panel plus variable back-of-panel engraving.
C Range C MAX (Black Knob) M (Black Knob)	S112 Fig. 1-3 (2)	6-position lever-switch	a. Used to select range of capacitance to be measured and automatically place decimal point on readout. b. Determines M factor by which CONDUCTANCE reading (if used) must be multiplied to compute value in micromhos, and by which EXT STANDARD must be multiplied, if used.	a. White vertical scale on front panel- C MAX 10:pf through 1 μ f. b. Red vertical scale on front panel- M : 1 - 1000.
CAPACITANCE Set of 6 (Gray Knobs)	S106 through S111 Fig. 1-3 (3)	12-position lever switches	Used to balance bridge and give direct reading on associated digital scale.	Horizontal, digital, window-type readout in PICO FARADS with automatically adjustable decimal point: 0 through 1, plus X and -1.
D MAX (Black Knob)	S101 (Partial) Fig. 1-3 (4)	3-position lever-switch	Used to select range of DISSIPATION FACTOR measurements and automatically place decimal point on readout.	Vertical scale (white): 1, 0.1 and 0.01.
G MAX (Black Knob)	S101 (Partial) Fig. 1-3 (4)	4-position lever-switch	Used to set range for CONDUCTANCE measurements and automatically place decimal point on readout.	Vertical scale (red): +0.1 μ Ω, +0.01 μ Ω -0.01 μ Ω, -0.1 μ Ω.
DISSIPATION FACTOR- CONDUCTANCE Set of 4 (Gray Knobs)	S102 through S105 Fig. 1-3 (5)	11-position lever switches	Used to balance bridge and give direct reading on associated digital scale.	Horizontal, digital, window-type readout with automatic decimal-point. (Affected by M setting, S112)
MULTIPLY EXT STANDARD BY M x.... AND ADD TO DECADE READING (Gray Bar Knob)	S114 Fig. 1-3 (6)	11-position rotary	Used to connect EXTERNAL STANDARD connectors to ground or to any of 10 taps on ratio-transformer of bridge.	Decimal window-type readout: 0 through 1. (Affected by M setting, S112)



TYPE 1615-A CAPACITANCE BRIDGE

1.3.2 BRIDGE CONNECTORS. Table 1-2 lists and describes all front-panel connectors found on the Type 1615-A Bridge.

1.3.3 GENERATOR CONTROLS AND CONNECTORS. Controls and connectors listed and described in Table

1-3 are on the front panel of the Type 1311-A Audio Oscillator.

1.3.4 DETECTOR CONTROLS AND CONNECTORS. Table 1-4 lists and describes controls and connectors on the Type 1232-A Tuned Amplifier and Null Detector.

**TABLE 1-2
CONNECTORS - TYPE 1615**

NAME	REF	TYPE	FUNCTION
GND	J101 Fig. 1-3 (A)	Binding Post, General Radio Type 938	Case ground.
GENERATOR	J102/J103 Fig. 1-3 (B)	Binding Post, General Radio Type 938, insulated	Receives input from external generator.
DETECTOR	J104 Fig. 1-3 (C)	Coaxial, General Radio Type 874	Shielded connection from bridge to external null detector.
EXT STANDARD* H & L	J105/J106 Fig. 1-3 (D)	Coaxial, General Radio Type 874	Shielded connection for external 3-terminal standards.
UNKNOWN H & L	J107/J108 Fig. 1-3 (E)	Coaxial, General Radio Type 874	Shielded connection for 3-terminal unknown capacitors.
UNKNOWN H, L	J110/J111 Fig. 1-3 (F)	Binding Posts, General Radio Type 938 (insulated)	Unshielded connection for 3- or 2-terminal unknown capacitors.
GND	J109 Fig. 1-3 (G)	Binding Post, General Radio Type 938	Case ground.

*Type 874-WO coaxial termination must always be installed on L connector unless capacitor is attached. Needed to shield sensitive DETECTOR input.

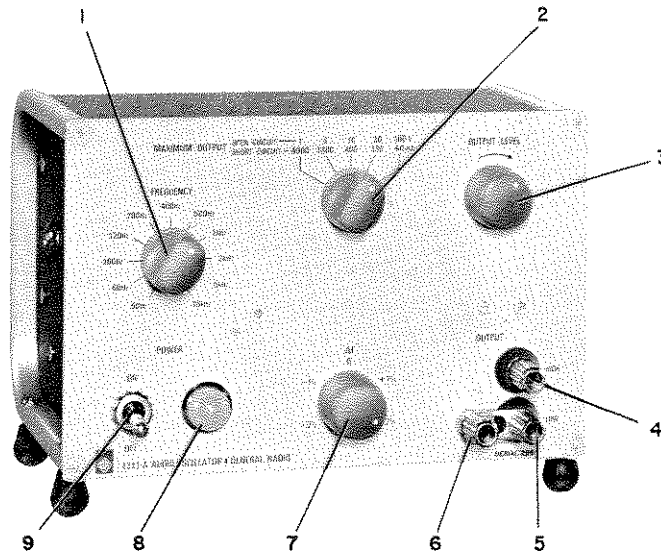

Figure 1-4. Type 1311 Audio Oscillator (see Table 1-3).

TABLE 1-3
CONTROLS AND CONNECTORS - TYPE 1311-A

REF FIG. 1-4	NAME	TYPE	FUNCTION
1	FREQUENCY	12-position rotary switch	Used to select output frequency.
2	MAXIMUM OUTPUT	5-position rotary switch	Used to select output transformer tap.
3	OUTPUT	Rotary Control	Used for fine output level variations.
7	ΔF	Rotary Control	Used to adjust output frequency ($\pm 2\%$ about nominal)
9	POWER	Toggle switch	Power ON/OFF control.
4-6	OUTPUT	Binding Posts (3) General Radio Type 938	Output terminals and ground.
	----	Power plug, General Radio Type 109-A	Power input terminal.
	----	Phone jack (on side panel)	Accept synchronizing signal from external frequency standard.



TYPE 1615-A CAPACITANCE BRIDGE

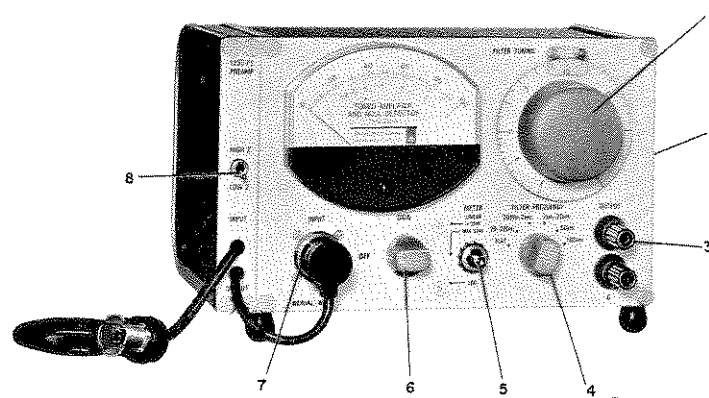

Figure 1-5. Type 1232-AP Tuned Amplifier and Null Detector (see Table 1-4). Consists of a Type 1232-A Tuned Amplifier and a Type 1232-P2 Preamplifier.

TABLE 1-4
CONTROLS AND CONNECTORS - TYPE 1232-A

REF FIG. 1-5	NAME	TYPE	FUNCTION
1	FILTER TUNING	Continuous rotary control	Tunes filter within selected tuning range.
4	FILTER FREQUENCY	6-position rotary switch	Selects desired frequency: tuning-frequency range of 20-200 cps, 200 cps-2 kc, or 2-20 kc; flat, 50-kc or 100-kc response.
6	GAIN	Rotary control	Turns instrument on or off and controls gain.
5	METER	Toggle switch	Selects linear or logarithmic response.
7	INPUT	Coaxial, General Radio Type 874	Input terminal.
3	OUTPUT	Binding Posts, General Radio Type 938	Amplifier output terminals (not used).
2	EXT FILTER	Phone jack	Connection for external filter.
8	HIGH Z - LOW Z (1232-AP only)	Toggle switch	Use HIGH Z position only when measuring small capacitances or small dissipation factors below 1 kHz.

SECTION 2

INSTALLATION

2.1 GENERAL.

The precision capacitance measuring system described in this manual may be obtained in four forms. Purchased as the Type 1620-A Capacitance Measuring Assembly it is complete, assembled and ready for bench use as shown in Figure 1-1. For those already in possession of either (or both) Type 1232-A Tuned Amplifier and Null Detector and Type 1311-A Audio Oscillator, these instruments may be readily combined with the Type 1615-A Capacitance Bridge to assemble a Type 1620-A.

An Adapter Set, Type 480-P316 and a pair of end frames, ZFR1-308-2R, -2L, are available to join the smaller instruments to one another and to the bridge and the three components so combined constitute a complete Type 1620-A Assembly. By use of the Type 1615-AM bridge with the Type 480-P316 Set plus end frames, a Type 1620-A suitable for bench use can be assembled. By use of a Type 1615-AR with the Type 480-P316 Set, a Type 1620-A suitable for rack mounting can be assembled.

Those planning to use detectors and generators other than General Radio Types 1232-A and 1311-A with either Type 1615 Capacitance Bridge may make similar combinations to suit particular needs and conditions.

2.2 TYPE 1620-A INSTALLATION.

2.2.1 SITING. The Type 1620-A Capacitance Measuring Assembly is a highly precise system for laboratory use. It is intended for bench mounting and is completely self-contained, requiring no further enclosure, such as racks or cabinets. Some open bench area around the assembly should be provided to support capacitors under test, or external standard capacitors, when used.

2.2.2 POWER INPUT. The Type CAP-22 Three-Wire Power Cord supplied should be attached to PL501 on the rear panel of the Type 1311-A Audio Oscillator and plugged into a standard grounding-type receptacle supplying ac power at 50 to 400 cps. The supply voltage,

105 to 125 or 210 to 250, should agree with that indicated on the engraving or nameplate near PL501. The Type 1232-A is battery operated and is shipped complete with batteries; the Type 1615-AM requires no power connection.

NOTE

If the Assembly has been stored for any prolonged period prior to installation, the batteries of the Type 1232-A should be checked. Refer to the operating instructions supplied separately for that instrument for the recommended procedures.

2.2.3 ENVIRONMENTAL CONSIDERATIONS. The Type 1620-A will operate within specifications under environmental conditions normally encountered in standards laboratories. While all internal capacitance standards used are virtually immune to environmental variations, it should be borne in mind that marked changes in temperature or humidity can have a considerable effect on the capacitors under test and thus degrade the precision measurements possible with this instrument assembly. Other special environmental considerations are as follows:

1. Type 1615-A --- high concentrations of dust obscure the read-out and stiffen the balancing controls.
2. Type 1311-A --- ambient temperatures should not exceed 50°C.
3. Type 1232-A --- strong magnetic or electrostatic fields should not be maintained close to this instrument.

2.2.4 OPEN-CIRCUIT TERMINATION. The Type 874-WO Open Circuit Termination is supplied as an accessory to shield the EXT STANDARD L coaxial connector. It may be stored on any unused coaxial connector on the Type 1615-A bridge without affecting the electrical performance of the circuit associated with the connector. Such a practice is recommended to prevent loss of the termination.



2.3 ASSEMBLY OF TYPE 1620-A.

2.3.1 GENERAL. The Type 1620-A consists of the following instruments: Type 1232-A Tuned Amplifier and Null Detector, Type 1311-A Audio Oscillator, Type 1615-A Capacitance Bridge. The Type 1232-A and Type 1311-A are available as the Type 1240-A Bridge Oscillator-Detector Assembly.

2.3.2 STACKMOUNTING. If the instruments are purchased separately, they can be combined to form the Type 1620-A Capacitance Measuring Assembly as follows:

Additional accessories required:

Quantity	Catalog Number	Description
1	0480-9636	Type 480-P316 Relay Rack Adaptor Set
1	0874-9682	Type 874-R22A Patch Cord
1	0274-9883	Type 274-NL Patch Cord
1	1620-7000	Nylon screw, 10-32
1	5810-3300	Nut, no. 10
*1	5310-3080	Right-hand end frame
*1	5310-3081	Left-hand end frame
*4	7660-2015	Spacers, 15/32" high
*4	7080-2900	Screws, 10-32 x 7/8"
*4	8040-2400	Lockwashers, no. 10
*4	5810-3300	Nuts, no. 10

* Not necessary if units are to be rackmounted.

Subassembly (see Figure 2-1):

- a. Remove the rubber feet from the Type 1232-A and 1311-A.
- b. Remove the screws that secure the front panel to the aluminum end frames and remove the spacers between the front panel and the end frames.
- c. On one instrument, install the clips with the front-panel screws removed above.
- d. Secure the two instruments together with front-panel screws through the remaining hole in each clip. Remove the covers, insert a nylon screw through the end panels, install a 10-32 nut, tighten, and replace the covers.

Note that the instruments can be bench-mounted in this manner: simply do not remove the feet from the outside end frames.

e. Install two clips on each adaptor plate with the wiring screws, lockwashers, and nuts supplied.

f. Install the adaptor plates to the instruments with the front-panel screws removed earlier.

g. Install the 5310-3080 and 5310-3081 end frames to the adaptor plates with the 10-32 screws and cup washers supplied.

h. Place the subassembly atop the Type 1615-A. Place two bushings between each end frame of the subassembly and the Type 1615-A, insert 7/8-inch screws through the end frames and bushings, install lockwashers and nuts, and tighten.

Electrical connections (see Figure 3-1):

i. Connect the Type 874-R22A Patch Cord between the DETECTOR terminal of the Type 1615-A and the INPUT terminal of the Type 1232-A.

j. At the OUTPUT terminals of the Type 1311-A, slide the shorting link away from the lower right-hand binding post.

k. Connect the Type 274-NL Patch Cord between the GENERATOR terminal of the Type 1615-A and the OUTPUT terminal of the Type 1311-A. The polarity indicators (screw heads) at the plug-ends of the cable must be at the left for the Type 1615-A connection and at the bottom for the Type 1311-A connection.

2.3.2 RACK MOUNTING. Follow paragraph 2.3.2 except do not install the 5310-3080 and 5310-3081 end frames and do not attach the oscillator-detector subassembly to the Type 1615-A. Remove the end frames from the Type 1615-A and install all units to the rack with 10-32 screws.

2.4 EQUIPMENT SUBSTITUTIONS.

Assemblies using the Type 1615-AM/AR Capacitance Bridge in combination with generators and detectors other than the Types 1311-A and 1232-A can be utilized. For instance, General Radio Type 1210-C Unit R-C Oscillator or Type 1310-A Oscillator and Type 1212-A Unit Null Detector, while not specifically designed for use with the Type 1615, will give excellent service.

In general, laboratory-type instruments which meet the following performance specifications should give adequate service when used with the Type 1615 Capacitance Bridge:

- 1. Generator - Stable sine-wave source with output power adjustable to a level not greater than 30 v/kc.
- 2. Detector - Tunable with 1 μv sensitivity, minimum.

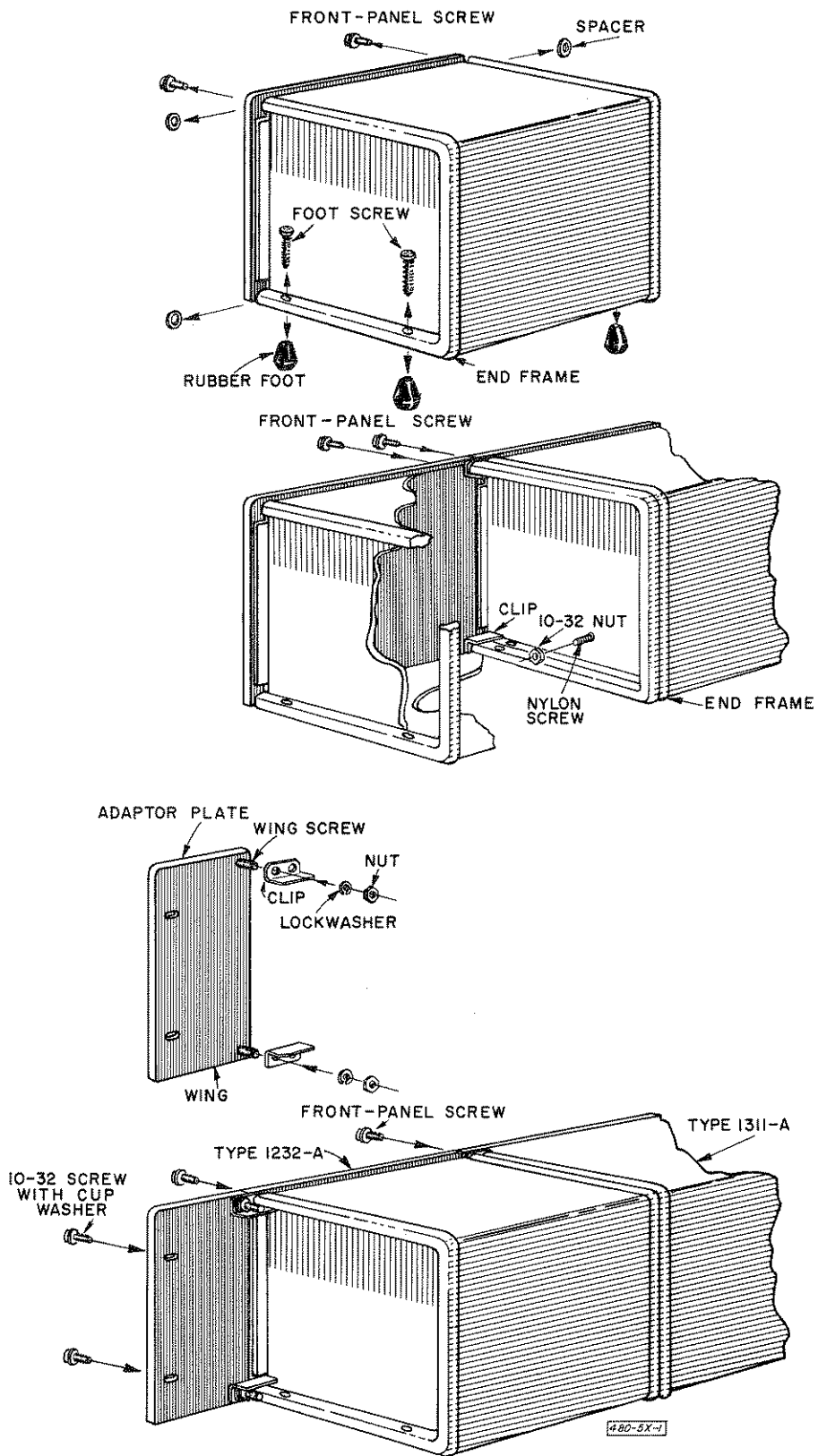

Figure 2-1.



SECTION 3

OPERATING PROCEDURES

3.1 GENERAL

Complete operating instructions are given in this section for the Type 1620-A Capacitance Measuring Assembly or a closely equivalent system assembled around a Type 1615-A Capacitance Bridge. It is recommended that Section 4, Theory of Operation, be read and understood when the equipment is first received, before performing the detailed procedures appearing in this section. Subsequently, for routine measurements, reference to the condensed operating-instruction sheet supplied should suffice. The sheet is laminated in clear plastic to permit frequent handling without deterioration. It is punched along the margin to permit insertion in standard three-ring binders. Alternatively, it is punched at the top so that it may be hung on the wall near the equipment, for maximum accessibility.

NOTE

Procedures which follow assume the use of the Type 1311-A as the generator and the Type 1232-A as the detector, both operating at 1 kc. For operational details, refer to the respective operating instructions for those instruments.

3.2 PREPARATION FOR USE

Prior to energizing the equipment, check that the following connections have been made (see Figure 3-1):

a. Type 1311-A OUTPUT to Type 1615-A GENERATOR (insulated) terminals via Type 274-NL Patch Cord.

NOTE

Polarity indicators (screw heads) at plugs must be at bottom for Type 1311-A connection and at left for Type 1615-A connection.

b. Type 1232-A INPUT to Type 1615-A DETECTOR coaxial terminals via Type 874-R22A Patch Cord.

c. Type 1311-A power cord to appropriate 3-wire ac outlet.

d. Type 874-WO Open Circuit Termination supplied is installed on EXT STANDARD L coaxial connector if no capacitor is to be connected there.

3.3 EQUIPMENT TURN-ON

3.3.1 BRIDGE. The Type 1615-A Capacitance Bridge is a purely passive instrument and has no primary power or turn-on requirements. Apply power to the generator and detector, and allow for warm-up time, as required.

3.3.2 GENERATOR. To adjust the Type 1311-A:

a. Set FREQUENCY selector to desired frequency.

b. Set MAXIMUM OUTPUT selector and OUTPUT CONTROL for a voltage level not greater than 30 volts per kilocycle (300V max):

1.8 V max at 60 Hz

3 V max at 100 Hz

30 V max at 1000 Hz

300 V max at 10 kHz

300 V max at 100 kHz

3.3.3 DETECTOR. To adjust the Type 1232-A:

a. Adjust FILTER FREQUENCY switch to approximate frequency of generator.

b. Rotate FILTER TUNING control to peak meter.

c. Set METER to LOG position.

d. Adjust GAIN control for midscale indication.

3.4 EQUIPMENT SELF-CHECK

As a check of the proper operation of bridge, generator, and detector, a bridge balance can be made at any time with no external capacitors connected. Proceed as follows:

a. Set terminal selector to CAL (all UNKNOWN L connectors are thereby removed from the bridge circuit).

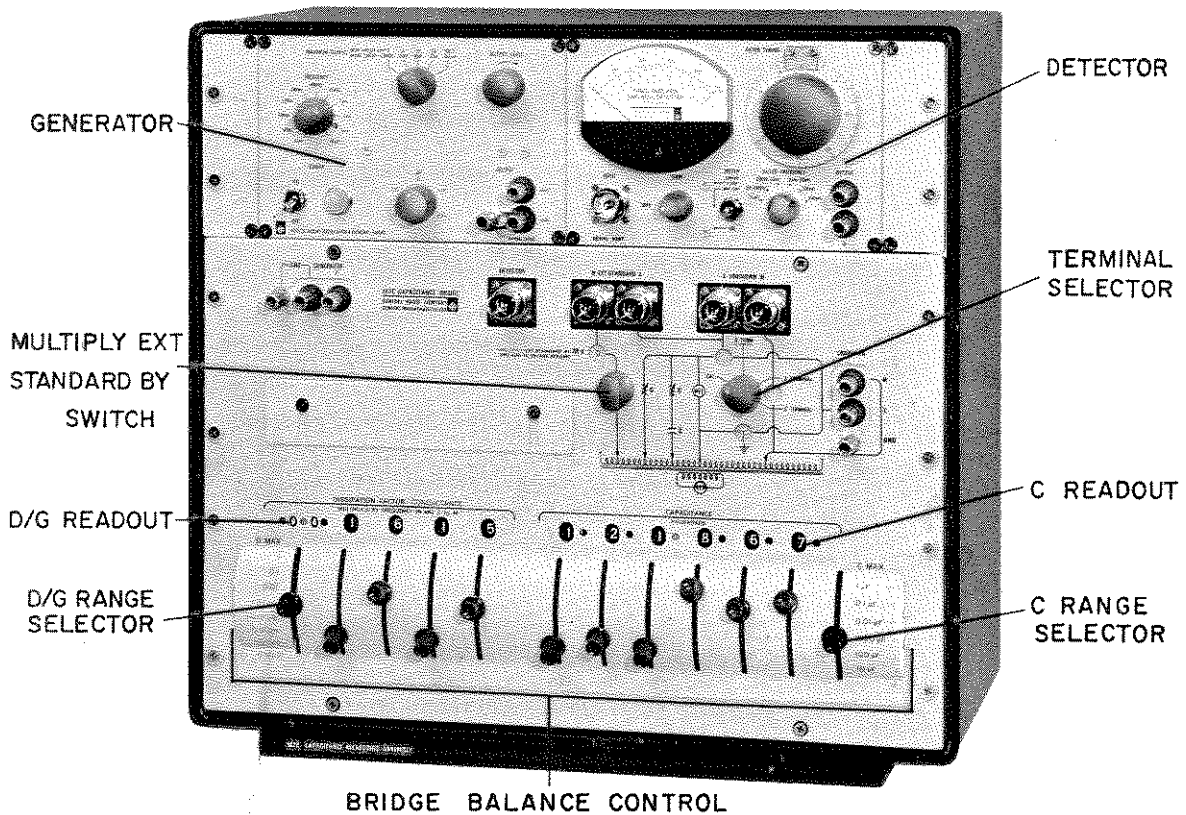

BRIDGE BALANCE CONTROL

Figure 3-1. Operator controls and indicators.

- b. Set MULTIPLY EXTERNAL STANDARD BY to 0.
- c. Set C MAX to any position.
- d. Set D MAX to 0.01.
- e. Null should occur with DISSIPATION FACTOR balance controls at 0000 and CAPACITANCE balance controls at 000000 (position of decimal point varies with C MAX settings). Detector deflection should increase if any CAPACITANCE balance control is moved from the 0 position. If balance is not accomplished, refer to Section 6. The foregoing is a qualitative, "proof-of-function", check only.

3.5 DIGITAL READOUT ON TYPE 1615-A

Digital readouts appear in windows directly above all balance controls, as do red decimal-point indicators, automatically positioned by range settings.

Direct six-digit CAPACITANCE readouts in picofarads (with appropriate decimal point) are provided in ranges determined by the position of the C MAX switch.

DISSIPATION FACTOR readouts of four digits in three ranges, dependent on D MAX switch settings,

are available with automatically positioned decimal. Readouts should be multiplied by frequency in kilocycles.

Direct four-digit readouts of CONDUCTANCE measurements, in μ mhos, are provided in four ranges determined by setting of the G MAX switch, which also places the decimal point. However, in the three highest capacitance ranges, this readout must be multiplied by the (red) M factor corresponding to the C MAX setting.

All readouts offer 0 through 9 indications plus X, which indicates 10. Thus a reading of 348X12 is equivalent to 349012.

In addition, the CAPACITANCE readout has a -1 position, which indicates that the corresponding unit of internal standard capacitance has been placed across the UNKNOWN arm of the bridge and is to be subtracted from the bridge reading. A reading of 348(-1)12 is equivalent to 348012 - 000100 = 347912.

CONDUCTANCE values add loss to the standard side of the bridge in +0.1 and +0.01 positions and to the unknown side in -0.1 and -0.01 positions. A negative G means the conductance of the unknown is the conductance of the internal and external standards minus the bridge G reading.



Decimal readouts in the MULTIPLY EXT STANDARD BY...window indicate the 11 steps by which the capacitor (if any) connected to the EXT STANDARD connectors can be varied.

3.6 BRIDGE BALANCE PROCEDURES

3.6.1 GENERAL. The following procedures apply for all modes of operation. Procedures for terminal selection and attachment of capacitor under test, which appear in paragraph 3.7, are here assumed to have been completed.

a. Move C MAX control to a setting slightly in excess of approximate value of capacitor being measured.

b. Set D MAX switch to 0.01 and set all DISSIPATION FACTOR controls to 0.

c. Position first (left-most) CAPACITANCE control for minimum deflection on detector meter.

d. To refine balance, position remaining CAPACITANCE controls, beginning at left and proceeding to right, until no further improvement occurs.

NOTE

To improve sharpness of balance indication, increase GAIN on detector, but restrict meter to lower half of scale.

e. Manipulate DISSIPATION FACTOR controls, starting with right-most, to refine balance further.

f. Alternately manipulate first CAPACITANCE and then DISSIPATION FACTOR controls until final null is accomplished. An increase in D MAX may be required.

NOTE

If no null can be achieved in D MAX positions, try G MAX settings (same lever switch).

g. Observe direct CAPACITANCE readout in picofarads in the six digital windows above controls, noting placement of red decimal point.

h. Observe direct DISSIPATION FACTOR reading, if appropriate, from digital windows above controls, noting placement of decimal point. At 1 kc, dissipation factor is as indicated; otherwise, multiply by frequency in kilocycles.

i. If appropriate, observe CONDUCTANCE in μ mhos, reading from digital windows above controls. Multiply reading by M factor (red engraving on C MAX dial) to calculate final value.

3.6.2 BALANCE PROCEDURE WHEN NOMINAL CAPACITANCE IS NOT KNOWN. To obtain a bridge balance when even an approximate magnitude of the unknown capacitance cannot be estimated, or when difficulty has been encountered in obtaining balance:

a. Set terminal selector in CAL position.

b. Set C MAX at 1 μ f.

c. Set CAPACITANCE decade controls at 001 000. pf.

d. Set G MAX to +0.1 μ Ω.

e. Set CONDUCTANCE decades to 0000.

f. Adjust detector GAIN control for about 1/3 full-scale deflection with meter set for LOG response.

g. Connect unknown to the appropriate terminals and switch terminal selector to corresponding position

NOTE

The voltage at the UNKNOWN terminals is only 0.001 times the generator voltage applied to the bridge, so there is little danger of damage to the bridge or capacitor.

h. Set CAPACITANCE decades to 000 000. pf.

i. Observe deflection of detector meter:

(1) If deflection is near the 1/3-full-scale reading to which it was set in step f, the unknown is a capacitance of the order of 1000 pf, or a conductance of the order of $5\mu\Omega$ (a resistance of 200 kilohms).

(2) If the deflection is much greater than 1/3 full scale, the unknown is a capacitance much larger than 1000 pf, or a conductance much larger than $5\mu\Omega$ (a resistance much smaller than 200 kilohms).

(3) If the deflection is much less than 1/3 full scale, the unknown is a capacitance much less than 1000 pf or a conductance much less than $5\mu\Omega$ (a resistance much greater than 200 kilohms).

j. Adjust CAPACITANCE decades, appropriate to the indicated magnitude, for minimum meter deflection by the usual bridge balance procedure (refer to paragraph 3.6.1).

k. If CAPACITANCE decade controls produce no indication of balance, adjust CONDUCTANCE decade controls.

l. When partial balance has been attained with these C MAX and G MAX settings, change to other C MAX and G MAX (or D MAX) positions as required for a balance to the desired precision.

3.7 CAPACITANCE BALANCE CONTROLS

The bridge has three principal modes of operation for capacitance measurement. They are determined by the setting of the terminal selector switch and the choice of UNKNOWN terminals made. In turn, these selections are determined by the nature of the unknown capacitor. Specific criteria for the proper selection of operating mode are supplied in the following paragraphs:

1. Three-terminal coaxial (para. 3.7.3).

2. Three-terminal binding post (para. 3.7.4).

3. Two-terminal binding-post (para. 3.7.5).

Procedures concerning the fourth (CAL) position of the terminal selector switch are covered in Section 6.

3.7.1 "C MAX" SWITCH.

1. When the nominal value of capacitance to be measured is not known, set the C MAX switch to 1 μ f and follow procedure of paragraph 3.6.2.

2. When the nominal value of capacitance is known, set C MAX to a position which makes the first significant figure of the bridge CAPACITANCE readout appear in the window of the first or second CAPACITANCE decade for maximum accuracy and precision.

See Figure 3-2 for an illustration of the bridge range of unknown capacitance vs the six positions of the C MAX switch and the readouts from 1 to X of the six CAPACITANCE decades. The "X" readout indicates that the value is in terms of the upper bound of the "unknown capacitance" range and the "1" indicates the lower bound.

Use any of the possible C MAX switch positions which has adequate resolution for direct-reading accuracy of 0.01%, when the capacitance can be measured on more than one position.

For the measurement of very small capacitance differences, use the C MAX position which gives the maximum number of significant figures in the CAPACITANCE readout. For minimum error in difference measurements, use the same internal standard capacitor for the first significant figure in all bridge readings. The internal capacitors used for each position of each CAPACITANCE decade are shown in the horizontal bars in the readout symbols in Figure 3-2.

For minimum error from external noise sources, use the C MAX position of maximum resolution. This gives maximum voltage at the UNKNOWN terminals

and maximum detector deflection for a given percent unbalance. The voltage between the UNKNOWN H and GND terminals, V_{HG} , for a voltage E_{GEN} at the bridge

GENERATOR terminals is

$$V_{HG} = E_{GEN} / M \quad (3-1)$$

where M is the multiplier from 1 to 1000 engraved on the C MAX switch and, shown at the far right in Figure 3-2. With C MAX at 1 μ f and M=1000, the voltage on the capacitor is 0.01 times that applied when C MAX is 0.01 μ f (M=10) and the voltage into the detector is proportionally reduced, so errors are more likely to appear on the 1 μ f C MAX position when noise sources are present.

Example (voltage across UNKNOWN terminals): If the maximum voltage of 30 V at 1 kHz is applied to the bridge GENERATOR terminals, the voltage across the unknown for the six C MAX ranges are:

C MAX	M	UNKNOWN volts for $E_{GEN} = 30V$
1 μ F	1000	0.03 V
0.1 μ F	100	0.3 V
0.01 μ F	10	3. V
1000 pF	1	30. V
100 pF	1	30. V
10 pF	1	30. V

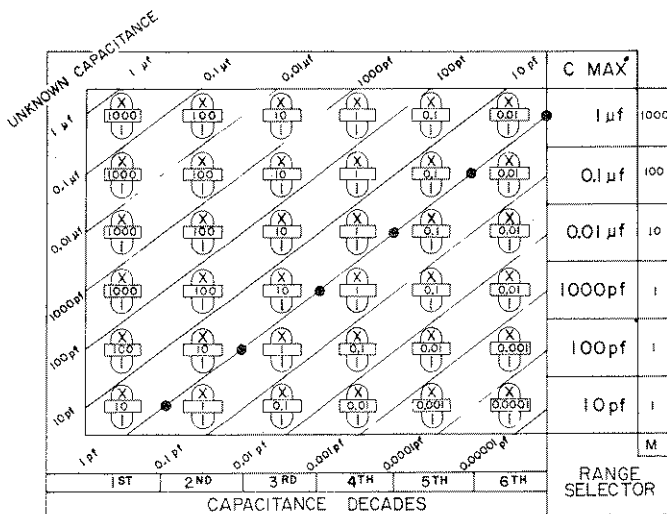

(X) READOUT AT DECADE MAXIMUM
 (100) INTERNAL STANDARD CAPACITOR (pF)
 (1) READOUT AT FIRST STEP OF DECADE

Figure 3-2. Selections of C MAX ranges for varying accuracy requirements in readout.

3.7.2 THREE-TERMINAL MEASUREMENTS. The two three-terminal measurement procedures applicable to this bridge are distinguished by the bridge connectors used. Measurements using coaxial terminations are covered in para. 3.7.3 and those using binding-post terminations in para. 3.7.4. Some considerations common to both are:

1. The measured direct capacitance is not changed in most three-terminal measurements when the connections to the capacitor are reversed, i.e., bridge H to capacitor L instead of bridge H to capacitor H.

2. The H terminal, at the high voltage but low-impedance output of the transformer, is not sensitive to pickup from external sources and seldom needs to be shielded. There is voltage from the H terminal to GND. High capacitance or conductance connected from the H terminal to GND reduces the transformer output voltage and introduces errors into the measured direct capacitance and conductance.

3. The L terminal, the low voltage but high-impedance input to the detector, is very sensitive to noise and signal pickup from external sources and must be completely shielded for low-capacitance mea-



TYPE 1615-A CAPACITANCE BRIDGE

measurements. There is no voltage from L to GND when the bridge is balanced. High capacitance or conductance from the L terminal to GND shunts the detector and reduces the sensitivity of the bridge.

3.7.3 THREE-TERMINAL COAXIAL CONNECTIONS (see Figure 3-3).

Used to Measure:

1. Three-terminal capacitors with shielded, coaxial connectors, such as General Radio Types 1403, 1404, 1422, and 1423.

2. Direct capacitance at the end of long, shielded cables, such as in a test chamber or in a remote equipment.

Terminal Selector: Set to 3 TERM position.

Terminals: Connect capacitor to UNKNOWN H and L coaxial terminals. Coaxial cable should always be used to connect L terminal (high-impedance side of detector). Unshielded lead may be used to connect to H terminal (low-impedance output of transformer), and, if coaxial connection is not used, the H binding

post should be used. Connect any three-terminal capacitor used as an external standard to EXT STANDARD H and L coaxial terminals. Coaxial cable should always be used to connect the L terminal (high-impedance side of the detector). Type 1403 series of capacitors or Type 1615-P1 Range-Extension Capacitor may be plugged directly into the H and L terminals, but care should be taken to align the connectors properly so that the conductors are not bent.

Bridge Balancing Procedures: As in paragraph 3.6

3.7.4 THREE-TERMINAL BINDING-POST CONNECTIONS (see Figure 3-4).

Used to Measure:

1. Three-terminal capacitors with unshielded, banana-plug connectors, such as Type 1409 series.

2. Capacitors with two terminals, when ground or cable capacitance must be excluded from the measurements; for example, capacitors measured with the Type 1650-P1 Test Jig.

Terminal Selector: Set to 3 TERMINAL position.

Terminals: Connect the capacitor to the UNKNOWN H and L binding posts. Connect the shields, or case, to the GND binding post. When long leads are used, shield the lead to the L binding post (high-impedance side of detector). For capacitors with two terminals and with one terminal connected to the capacitor case or shield (which can be insulated from external ground) connect the case to the bridge H terminal (low-impedance output of transformer).

Capacitance Measured: Direct capacitance between the H and L binding posts, including about 0.2 pF capacitance between the open posts, C_{HL} .

Capacitance Excluded: All capacitances, C_G , to ground from either H or L posts. Any GND terminal on the bridge is a guard point. To determine the capacitance added by the unknown capacitor:

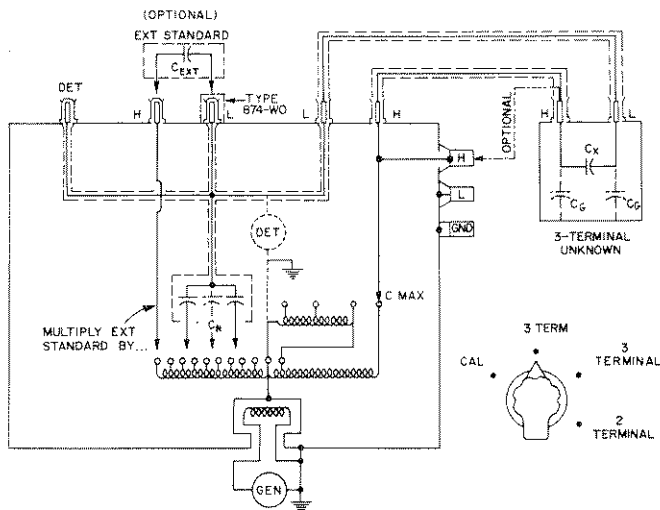

Figure 3-3. Type 1615-A bridge circuit for 3-terminal coaxial measurement.

post should be used. Use Type 874-R20A or -R22A Patch Cord, with appropriate Type 874 coaxial adaptor, if required.

Capacitance Measured: Direct capacitance, C_X , between H and L terminals.

Capacitance Excluded: All capacitances, C_G , to ground, including cable capacitances. Any GND or coaxial outer-conductor terminal on the bridge is a guard point.

External Standard: Not required for most measurements. May be used to extend range and resolution of bridge; refer to Section 5. When EXT STANDARD terminals are not used, install Type 874-WO termination on EXT STANDARD L coaxial terminal to complete shielding of the detector.

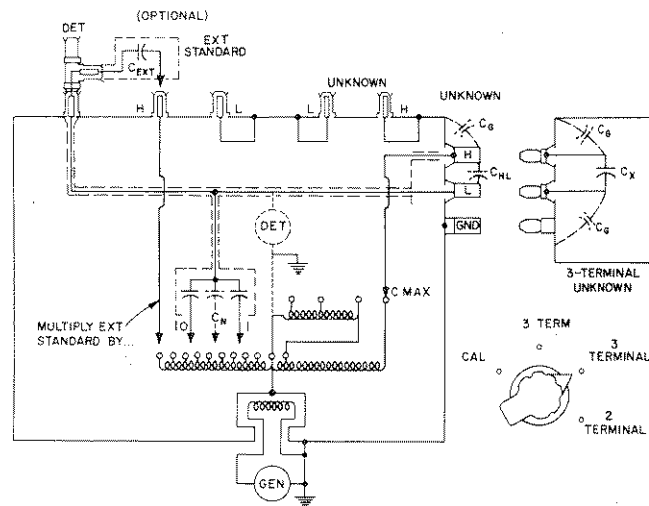

Figure 3-4. Type 1615-A bridge circuit for 3-terminal binding-post measurement.

- a. Remove the capacitor from the bridge terminals or leads.
- b. Measure the capacitance of the open terminals (about 0.2 pf) or open leads.
- c. Subtract this capacitance from the total capacitance measured with the capacitor connected.

External Standard: Not required for most measurements. May be used to extend range and resolution of bridge; to use external standards, refer to Section 5. Connect any three-terminal capacitor used as an external standard to the EXT STANDARD H coaxial terminal and to the detector through a coaxial-Tee connector (Type 874-T), at the bridge DETECTOR terminal. Use coaxial cable for the connection to the detector.

NOTE

The bridge L coaxial terminals cannot be used because they are connected to ground instead of to the detector when the terminal selector is in this position.

When EXT STANDARD terminals are not used, the Type 874-WO termination is not required on EXT STANDARD or UNKNOWN L coaxial connectors; these connectors are internally grounded.

Bridge Balancing Procedures: Refer to paragraph 3.6.

3.7.5 TWO-TERMINAL BINDING-POST CONNECTIONS
(see Figure 3-5).

Use to Measure:

1. Two-terminal capacitors with banana-plug connectors, such as the Type 1401 and 1409 series.
2. Capacitors with capacitance greater than 1 μ f, whose leads must be short to reduce loss, such as the Type 1424-A.
3. Capacitors with one lead permanently connected to an external ground.

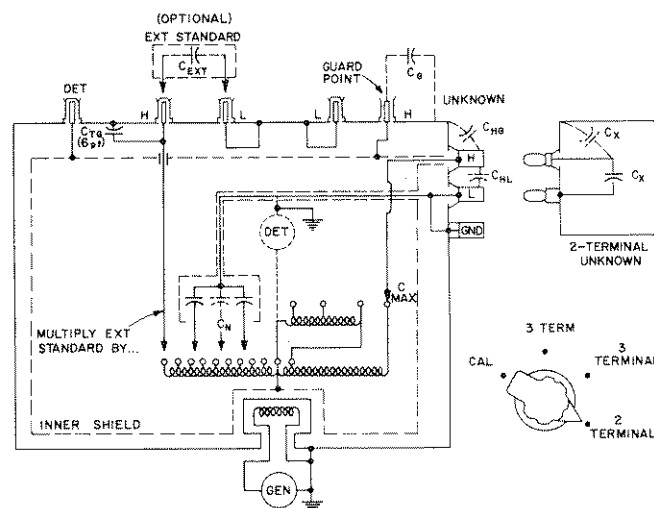

Figure 3-5. Type 1615-A bridge circuit for 2-terminal capacitance measurement.

Terminal Selector: Set to 2 TERMINAL position.

Terminals: Connect capacitor to the UNKNOWN H and L binding posts, with the case, low, or ground side of the capacitor connected to the L post. The L post is internally connected to the GND post.

Connect any bridge GND terminal to an external ground to eliminate changes in the bridge balance which may be produced by motion of the operator's hands near the balance controls (not in the vicinity of unshielded UNKNOWN terminals). Adequate grounding is provided through the three-wire power connection of the Type 1311-A oscillator. If the oscillator ground is not otherwise connected to the bridge ground, do so with a clip lead. The bridge GENERATOR gray binding post is internally connected to GND.

Capacitance Measured: All capacitances from the H post and leads to the L and GND posts, to the bridge case, and to external grounds, including about 1.3 pf capacitance between the open H posts and the grounds around it, C_{HG} , C_{HL} .

Capacitance Excluded: Only capacitances inside the bridge to the shields, which are connected to the transformer center tap and to the high side of the detector. A guard point, connected to the inner shields, is accessible at the UNKNOWN H coaxial terminal center conductor and at the DETECTOR coaxial terminal center conductor. Since the guard point is also the high side of the detector, any guard connections used outside the bridge must usually be enclosed in a grounded shield to prevent noise from entering the detector.

To determine the capacitance added by the unknown capacitor:

- a. Remove the capacitor from the bridge terminals or leads.
- b. Measure the capacitance of the open terminals (about 1.2 pf) or open leads.
- c. Subtract this capacitance from the total capacitance measured with the capacitor connected.

External Standard: Must be a 2-terminal capacitor. Not required for most measurements. May be used to extend range and resolution of bridge; refer to Section 6.

When EXT STANDARD terminals are not used:

- a. Set MULTIPLY EXT STANDARD BY... switch to 0.
- b. Remove Type 874-WO termination from EXT STANDARD or UNKNOWN L coaxial connectors; these connectors are internally grounded.
- c. Install Type 874-WO on UNKNOWN H coaxial connector (which is connected to high side of detector) when complete shielding is required, as in the measurement of very small capacitance differences.

When EXT STANDARD terminals are used:

- a. Connect any two-terminal capacitor used as an external standard to the EXT STANDARD H coaxial-terminal center conductor and to any ground, such as the outer conductor, or the L terminal (inner or outer) or either GND post.



b. Convert the coaxial H terminal to two binding-post H and L terminals for convenient connection of two-terminal capacitors with Type 874-Q2 adaptor.

c. Convert the coaxial H terminal to a single binding-post H terminal with Type 874-MB Coupling Probe.

NOTE

When the MULTIPLY EXT STANDARD BY ... switch is not set to 0, external capacitance is added to the bridge even though no external capacitor is connected to the bridge. Capacitance to ground in the EXT STANDARD H coaxial connector and internal bridge wiring, C_{TG} , (about 6 pf), acts as external standard capacitance, and any adaptors or wires connected to the EXT STANDARD H terminal add to this.

3.8 LOSS BALANCE CONTROLS.

3.8.1 GENERAL. The loss balance in the bridge can be made in terms of either the dissipation factor, D, or the parallel conductance, G, of the unknown capacitor (see Figure 3-6).

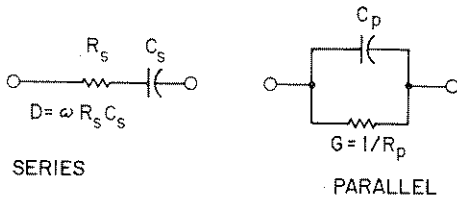

Figure 3-6. Equivalent circuits of unknown capacitors.

On the D MAX ranges, the bridge measures the equivalent series capacitance, C_s , and the dissipation factor, $D = \omega R_s C_s$.

On the G MAX ranges, the bridge measures the equivalent parallel capacitance, C_p , and the parallel conductance, G. Many measurements can be made with either D or G and C_s or C_p . When only one can be measured, the other can be calculated from the relations:

$$D = \omega R_s C_s = G / \omega C_p = 1 / \omega R_p C_p \tag{3-2}$$

$$C_s = C_p (1 + D^2) \tag{3-3}$$

$$G = 1/R_p = \omega C_s D / (1 + D^2) \approx \omega C_s D \tag{3-4}$$

$$R_s = G / [(\omega C_p)^2 (1 + D^2)] \approx G / (\omega C_p)^2 \tag{3-5}$$

- where C = capacitance in farads
- G = conductance in mhos
- R = resistance in ohms
- $\omega = 2\pi f$
- f = frequency in cps

NOTE

Any error in generator frequency affects the accuracy of a conversion from G to D or from D to G. Dial calibration of most oscillators is no better than $\pm 1\%$. For D or G calculation accuracy of $\pm 1\%$ or better, measure frequency to higher accuracy or use source of standard frequency.

Some of the differences which determine the choice of D or G appear below.

3.8.2 DISSIPATION FACTOR, D. For many measurements, the dissipation-factor or D MAX ranges provide the greater range, accuracy, and convenience in loss balance.

Range: At 1 kc, .000 001 to 1. Multiply by frequency in kilocycles. Independent of capacitance. Four-figure resolution. Smallest increment, 1 ppm at 1 kc. Accuracy: Basic D accuracy is $\pm(0.1\%$ of measured value +10 ppm) at 1 kc and over most of the range from 50 cycles to 10 kc.

Principle Uses:

1. For general capacitance measurements in which the primary interest is the capacitance value.
2. When the capacitor loss and D are relatively high, e.g., D greater than 0.01.
3. For accurate measurement of capacitor loss.
4. When an external standard is used to measure large capacitance with high loss. Accurate C and G can then be obtained from the bridge readings only by computation. Refer to Section 4.
5. When the loss in the unknown capacitor is primarily equivalent series resistance, e.g., the lead resistance of capacitors with low reactance. The bridge reading of D is then related in a simple manner to the resistance of the unknown as frequency changes.

Corrections:

1. Multiply reading of bridge decades by frequency in kc when operation frequency is not 1 kc.
2. For maximum accuracy in the measurement of small D or small differences, add 1 to reading of fourth decade. Minimum resistance of decade switches and wiring when the four decades are set at 0000 is about 0.1 ohm, which is one step in fourth resistance decade.

3.8.3 CONDUCTANCE, G. Conductance ranges (G MAX) are provided primarily to permit loss balances if dissipation-factor measurements cannot be used. The range and accuracy of G are generally lower than those of D.

Range: .000 001 to 0.1 μ mho, multiplied by factor M=1, 10, 100, or 1000, determined by C MAX range selected. Two positive ranges add G to internal standards; two negative ranges add G to unknown. All are independent of frequency.

TABLE 3-1
D EQUIVALENTS FOR MAX AND MIN G WHEN C_X EQUALS C_{MAX}

RANGE SETTING		D AT 1 KC FOR C _X = C _{MAX} WITH	
C _{MAX}	M	MAX G (0.1 x M) μΩ	MIN G (.000 001 x M) μΩ
1 μf	1000	.016	.000 000 16
0.1 μf	100	.016	.000 000 16
0.01 μf	10	.016	.000 000 16
1000 pf	1	.016	.000 000 16
100 pf	1	.16	.000 001 6
10 pf	1	1.6	.000 016

Notes:

1. For any other unknown capacitance or C MAX range, multiply D values by C_{MAX}/C_X.
2. For any other frequency, f, multiply D values by 1/f(kc).

Example: 100 pf measured at 100 cps with C MAX set at 1000 pf.
 Max D = .016 x (1000/100) x (1/0.1) = 1.6.
 Min D = 0.16 ppm x (1000/100) x (1/0.1) = 16 ppm = .000016.

Dissipation factor, D, corresponding to a given G, depends upon frequency and capacitance; the relation is:

$$D = \frac{G (\mu\text{mhos})}{6.28} \times \frac{1}{f(\text{kc})} \times \frac{1000}{C(\text{pf})} \quad (3-6)$$

where G is the bridge readout in μmhos multiplied by M.

D values from this equation are given in Table 3-1 for the maximum and minimum G of the bridge at 1 kc and for six values of unknown capacitance, C_X, equal to the nominal minimum capacitance of the six C MAX ranges.

Accuracy: Basic G accuracy is ±(1%+0.00 001 μmho). This is independent of frequency from 50 cycles to 10 kc.

Principal Uses:

1. When the loss of the unknown is less than that of the internal and external standard capacitors. This may occur in the measurement of reference standard capacitors, whose loss is extremely low, and in measurements with an external standard capacitor connected to the bridge. Balance the loss by using the -0.1 or -0.01 μmho G MAX ranges to connect the bridge conductance decades across the unknown.

2. When the internal standard capacitors are compared for a ratio check. The dissipation factor re-

sistance decades are connected in series with the common side of all bridge capacitors and provide no adjustment of the loss of any one relative to another.

3. When the minimum D equivalent to the smallest G step provides better resolution for precision balance (see Table 3-1). For example, in the measurement of 1000 pf at 1 kc, the smallest step of adjustment with the D MAX ranges is 1 ppm; with the minimum G step of 1 x 10⁻⁶ μmho, the resolution of the equivalent D is 0.16 ppm.

4. When the loss of the unknown is primarily equivalent parallel resistance, e.g., the leakage resistance of insulators in air capacitors of high reactance. The loss balance is then relatively independent of frequency.

Corrections:

1. Multiply reading of bridge decades by factor M, which is indicated on C MAX switch. Error in decimal point often results from the omission of M for the C MAX ranges above 1000 pf, where M is not 1.

2. For maximum accuracy in the measurement of small G or small differences, add 1 to the reading of the fourth decade. Minimum resistance of the decade switches and wiring, when the four decades are set at 0000, is about 0.1 ohm, which is one step in the fourth resistance decade.



NOTE

As a result of this zero error, the bridge balance will change when the decades are set at 0000 and the G MAX is moved from +0.01 $\mu\Omega$ to -0.01 $\mu\Omega$. When the correction is applied, the two conductances are +.000 001 and -.000 001 μmho , respectively. To obtain conductance less than this minimum for some capacitances and frequencies, use D MAX ranges and calculate equivalent G (see Table 3-1).

Example: For 10 pf at 1 kc, minimum G of .000 001 μmho corresponds to D of 16 ppm. On 0.01 D MAX range, minimum D is 1 ppm, and equivalent G is .000 000 06 μmho .

3. For accuracy of $\pm 1\%$ when the first G decade reading is 3 or more, apply the corrections indicated in Figure 3-7. These corrections are necessary because the relation of G to the resistance, RN, of the decades is not linear. (Refer to Section 4.)

To use Figure 3-7.

a. Take the four-digit reading of G dials (for example, 7413). Ignore the position of decimal point and units of G.

b. Enter the vertical "G Decades Read" scale at this value and, at the intersection with the curve, find on the horizontal "Subtract from Reading" scale, the corresponding correction value (110).

c. Subtract the correction from the reading to obtain the corrected G, with an accuracy of $\pm 1\%$ ($7413 - 110 = 7303$).

d. The units of G and the position at the decimal point are those indicated by the bridge readout.

For greater precision in the correction than that obtainable from Figure 3-7, to be used, for example, in measurements of G differences, calculate the correction as follows:

a. Divide the four-digit G reading by 1000. ($7413/1000 = 7.413$.)

b. Square this number (55.0 with slide-rule accuracy).

c. Multiply by 2 (110.0).

d. Subtract this from the reading to obtain the corrected G ($7413 - 110 = 7303$).

3.9 ERRORS FROM TRANSFORMER IMPEDANCES AND OTHER SOURCES

3.9.1 INTRODUCTION. The transformers in the Type 1615-A Bridge are not quite the ideal transformers shown, for example, in Figures 4-11 and 4-12. The resistance, leakage inductance, and capacitances of the ratio-transformer windings, which are assumed to be zero in the simplified bridge theory, have been kept sufficiently small in the actual bridge components so that the errors from these residual impedances are usually negligible (compared to, say, 100 ppm) for capacitances

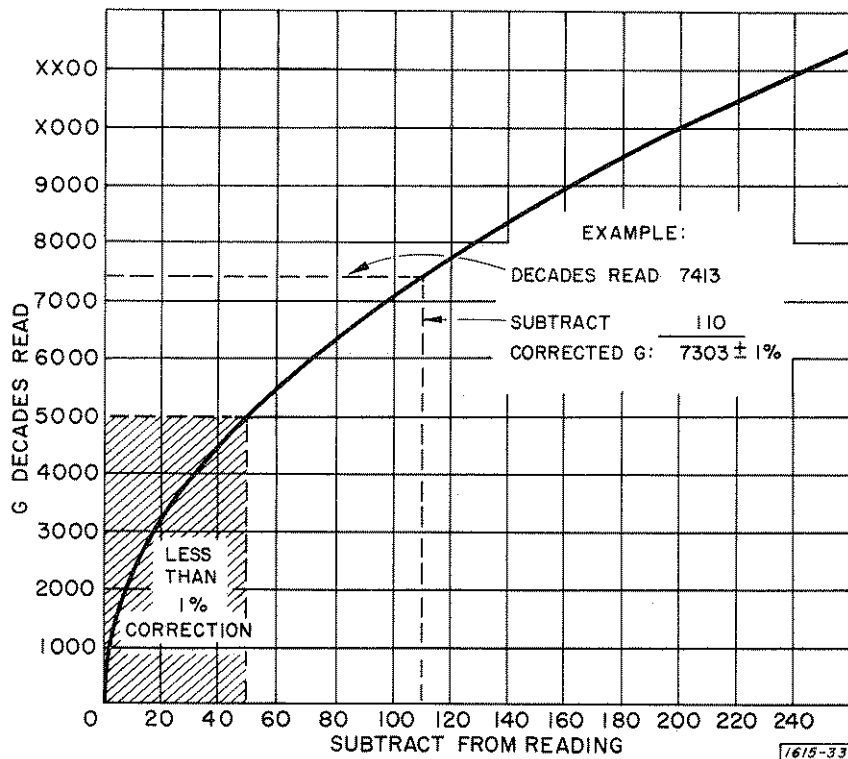

Figure 3-7. Corrections for high G readings.

up to 1 μF at frequencies up to 1000 cps. However, the residual impedances make the voltages at the transformer terminals differ from the voltages induced in the windings and produce bridge errors that increase with frequency and with the magnitude of the measured capacitance. The sources and magnitudes of such error for frequencies from 1 kc to 100 kc and for capacitances above 1 μF will be described in the following paragraphs.

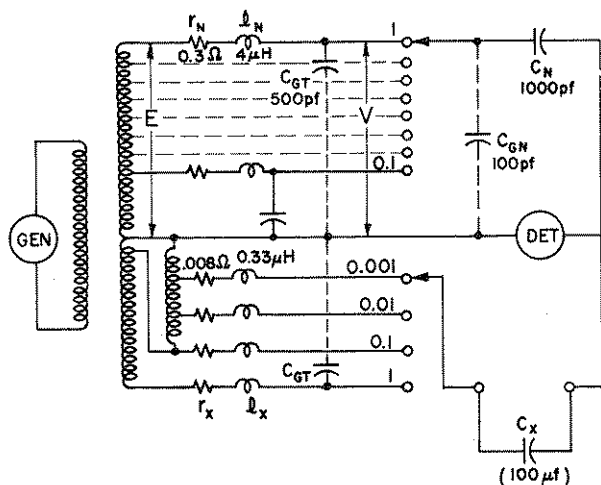

Figure 3-8. Bridge circuit with residual transformer impedances.

3.9.2 RESIDUAL IMPEDANCES. The bridge schematic diagram of Figure 3-8 is similar to that of Figure 4-11 but shows in the equivalent circuit of the transformer winding resistances (r), leakage inductances (l), and winding capacitances (C_{GT}) in both the standard and unknown ratio arms. The magnitudes of the residuals vary on the standard side as the lever decade switches are moved to change voltages and on the unknown side as the C MAX lever is moved to change range. The resistance r and inductance l are closely proportional to turns ratio from 1 to 10, but the minimum values set by wiring and switches prevent a proportional decrease for higher ratios. Typical values of r and l are given in the following table:

C MAX	M	Turns	r	l
10, 100, 1000 pF	1	100	0.33 Ω	3.5 μH
.01 μF	10	10	.019	0.41
0.1	100	10	.023	0.48
1	1000	1	.008	0.33

The winding capacitances (C_{GT}) are not simply proportional to turns. An estimate of the order of magnitude of capacitance across each 100-turn secondary winding is 500 pF, but the capacitance across the first 10-turn section is about 0.01 μF instead of ten times the capacitance of the 100-turn winding.

These residual impedances (as shown in the circuit of Figure 3-8) make the voltage, V , applied to the capacitors differ from the voltage, E , induced in the transformer winding.

The relation of V to E is:

$$V/E = 1 + \omega^2 l C_T - j\omega r C_T \quad (1)$$

$$\text{where } C_T = C_N + C_{GT} + C_{GN}$$

This change in the voltage applied to the capacitor C_N , for example, can be expressed for convenience as a change in the effective capacitance, C'_N , of C_N , when the bridge is at balance, through the relation $EC'_N = VC_N$. The effects of the residual impedances on the bridge readings can then be written:

- a. The capacitance C'_N is greater than C_N :

$$C'_N = C_N (1 + \omega^2 l C_T)$$

The fractional increase is $\omega^2 l C_T$.

This error is proportional to frequency squared.

- b. The dissipation factor of C'_N is greater than that of C_N (which is assumed to be zero in Figure 3-8.)

$$D'_N = +\omega r C_T$$

This error is proportional to frequency.

- c. The equivalent conductance ($G = D\omega C$) is increased.

$$G'_N = \omega^2 r C_T C_N$$

This error is proportional to frequency squared.

3.9.3 MAGNITUDE OF ERRORS. Errors from the transformer impedances are always present; they are not always significant. To determine when the errors may not be negligible, consider two typical, although oversimplified, numerical examples.

An order of magnitude for the effects of the residuals upon the standard capacitors in the bridge can be found, first of all, from the numerical values given for components on the upper or standard side of the bridge in Figure 3-8. The largest internal capacitor, C_N , of 1000 pF is shown connected to the full 100-turn secondary winding, with $r = 0.3 \Omega$, $l = 4 \mu\text{H}$ and $C_{GT} = 500 \text{ pF}$. With the ground capacitance of the capacitor C_N and the associated wiring equal to 100 pF, the total load capacitance connected to the transformer is $C_T = 1600 \text{ pF}$. From the error formulas above, the calculated possible errors at frequencies of 1 kc and 100 kc are:

Frequency	C error $\omega^2 l C_T$	D error $\omega r C_T$
1 kc	0.26 ppm	3.0 ppm
100 kc	2600 ppm or 0.26%	300 ppm or 0.03%



These figures are intended only to indicate that these errors can often be neglected at 1 kc but that, as the frequency is increased toward 100 kc, the bridge errors may exceed considerably the normal 0.01% limit.

As an example of the effects of residuals upon the measurement of large capacitance, consider the numerical values shown on the lower or unknown side of the bridge in Figure 3-8. An unknown capacitor of 100 μ F is shown connected to the transformer tap for a ratio $M = 1000$ (C_{MAX} at 1 μ F), where $r = .008 \Omega$, $l = 0.33$, and the winding capacitance is negligible compared to 10 μ F. (The bridge will not balance with only the 1000-pF standard capacitor shown in Figure 3-8; an external standard of 0.1 μ F must be used in the measurement of 100 μ F, but need not be considered in this example.) The calculated errors for the 100- μ F capacitor and also for a 1- μ F unknown at a frequency of 1 kc are:

Capacitor	C error	D error
1 μ F	13 ppm	50 ppm
100 μ F	1300 ppm or 0.13%	5000 ppm or 0.5%

The figures indicate that these errors can often be neglected for the normal capacitance range up to 1 μ F at 1 kc. With higher capacitance or with a higher frequency, the errors may be appreciable.

Both examples above illustrate only the order of magnitude of possible errors. Since all error sources in the circuit have not been included, the calculated errors should not be taken as typical of a Type 1615-A Bridge. A more detailed examination of actual bridge errors will follow.

3.9.4 SMALL ERRORS FOR 1:1 RATIO. The errors in the bridge readings can be determined by the measurement of a calibrated capacitor. A convenient standard of capacitance and loss is a three-terminal air capacitor, such as the Type 1403, that can be connected directly to the bridge terminals to add a minimum of series inductance and resistance. For such a capacitor, it can be assumed with good accuracy that the capacitance and loss have negligible changes with frequency up to about 100 kc and that any changes in bridge readings with frequency indicate bridge errors. In the 1000-pF Type 1403, for example, the internal series inductance is about 0.05 μ H, so the capacitance increase at 100 kc should be only $\omega^2 IC = 20$ ppm. Although the dissipation factor is not generally a simple function of frequency, in a clean air capacitor the magnitude should be sufficiently low, i.e., in the tens of ppm, that it can also be neglected.

The following results were obtained when such a 1000-pF Type 1403-A Capacitor was measured on a Type 1615-A Bridge. The capacitor was slightly modified by the addition of a series 16-ohm resistor to insure that the bridge D reading remained positive.

Frequency	D	C	C Change from 1 kc
1 kc	.00 0110	X00.747 pF	0
10	.00 0107 (x10)	.745	- 2 ppm
50	.00 0107 (x50)	.710	- 37
100	.00 0108 (x100)	.480	- 267

Note that the capacitance change at 100 kc is only 267 ppm, as compared to the estimated possible error of 2600 ppm above. The smaller error results from a partial cancellation of transformer-impedance errors in the two ratio arms of the bridge. When, as in this example, the ratio is 1:1, the residual r and l are equal on both the standard and unknown sides of the transformer in Figure 3-8. If the total load, C_T , is the same on both sides, the errors in V are equal and make $V_N/V_X = E_N/E_X$ and at balance $C_X = C_N$ at any frequency.

In this example, and in general, the errors in the two bridge arms do not quite cancel because the total C_T on one side does not equal that on the other. The internal and external stray capacitances to ground, C_{GN} and C_{GX} , are seldom equal since the bridge shields and wiring make C_{GN} relatively high. The voltage on the standard side is, therefore, usually higher, and the bridge capacitance decade readings are low. For example, an excess C_{GN} of 100 pF makes the bridge reading low by 160 ppm at 100 kc.

This error changes with any changes in the internal ground capacitances, such as those produced by any changes of decade switches to select alternative internal standards. In the following example, the same 1000-pF capacitor is measured with two of the several possible decade settings:

1 kc	100 kc
X00.747	X00.480
9X0.747	9X0.310

The 100-kc reading is lower for the decade setting of 9X0 than for X00 because the capacitance to ground has changed. With the X00 setting, only the internal 1000-pF standard and its ground and wiring capacitance load the transformer; with the 9X0 setting, both the 1000-pF and 100-pF standards are connected and the ground capacitance is increased about 100 pF.

The D readings in the example above seem at first glance to change very little with frequency. When, however, the bridge reading is multiplied by frequency in kc, as indicated, the change at 100 kc is -200 ppm. The uncertainty in this error is of the order of ± 100 ppm, both because the bridge resolution is only 100 ppm and because the loss in the standard may vary by a similar amount. The bridge D error is probably less than the 200 ppm at 100 kc.

For a bridge ratio of 1:1, therefore, the bridge errors in C and D are typically less than, say, 500 ppm at 100 kc. The C error is proportional to frequency squared and the D error to frequency. It is not usually practical to apply corrections for these errors to the bridge readings, chiefly because the magnitudes of the stray capacitances to ground and their variations with decade settings are not easily determined.

3.9.5 LARGER ERRORS FOR 10:1 RATIO. Bridge errors from transformer residuals can, in theory, be reduced or eliminated by symmetry in the bridge circuit for any transformer ratio, just as in the example of the 1:1 ratio. All that is required is that $\omega^2 l_X C_{TX} = \omega^2 l_N C_{TN}$ or $l_X/l_N = C_{TN}/C_{TX}$ to make $C_X = C_N$; hence, the residuals should be proportional to the ratio.

In practice, there are several reasons why the errors, $\omega^2 l C_T$ or $\omega r C_T$, cannot be kept the same on both sides of the bridge as the ratio is increased. The residual impedances r and l , tabulated above in paragraph 3.9.2, differ slightly from proportionality to ratio up to a 10:1 ratio. For higher ratios, the r and l on the unknown side cannot decrease in proportion below the minimum values set by the wiring, switch, and terminal impedances. Any wires used to connect the unknown to the bridge will increase these residual impedances. The capacitance residuals are also seldom proportional to ratio. Although the bridge ratio is determined by the ratio of the unknown and standard capacitances, C_X/C_N , the error depends upon total capacitance in the bridge arm, e.g., $C_{TN} = C_N + C_{GT} + C_{GN}$; and neither the transformer-winding capacitances, C_{GT} , nor the ground capacitances of the capacitors, C_{GN} , are proportional to ratio.

With a 10:1 ratio, the following bridge errors appear when a 100-pF Type 1403-D Capacitor is measured. The C MAX switch is set at 1000 pF so that the bridge balances with the decades set near 100.00, i.e., the external 100 pF is connected to the 100-turn arm and balanced by the internal 1000-pF standard connected to 10 turns of the other arm.

Frequency kc	G μS	D = G/ ωC ppm	C ppm	C Change from 1 kc
1	+ .00 0010	16	100.011	0 ppm
10	+ .00 0030	5	100.008	-30
50	- .0046	-150	10(-1).956	-550
100	- .030	-500	10(-1).843	-1670

The error of nearly 0.2% at 100 kc is produced by the relatively large winding capacitance of the 10-turn winding and ground capacitances on the standard side of the bridge, which are not compensated by proportional capacitances of the 100-turn winding and the 100-pF unknown.

For a ratio of 10:1, the bridge errors in C may be as high as 0.2% at 100 kc. The errors are again dependent upon decade settings and stray capacitances in the unknown, so that corrections are not easily made.

3.9.6 ERRORS FOR RATIOS ABOVE 10, CAPACITANCE ABOVE 0.01 μF . When the capacitance being measured is of the order of 1000 pF or less, the bridge errors depend more upon winding and stray capacitances than upon the magnitude of the unknown, as shown above. When the unknown is considerably greater than 1000 pF, the bridge ratios of 100 or 1000 must be used for balance. The transformer residuals on the unknown side of the bridge then are much larger than 0.1 or 0.01 times those on the standard side. At the same time, the winding and stray capacitances become a small fraction of the total C_{TX} on the unknown side. As a result, the bridge errors not only increase with the larger C_X but become more simply dependent upon $\omega^2 l_X C_X$ and $\omega r_X C_X$.

As an illustration, the following measurements were made of a 0.1- μF Type 1409-T Capacitor on the 0.1- μF C MAX range, where M = 100.

Frequency kc	D	C pF	C Change from 1 kc
1	.00 0060	999 74.1	0
10	.00 0016(x10)	999 93.7	0.02%
50	.00 0025(x50)	X05 54.5	0.58%
100	.00 0037(x100)	X21 30.0	2.16%

When C MAX is at 0.1 μF , the transformer leakage inductance l_X is, typically, about 0.48 μH ; so for 0.1 μF at 100 kc, $\omega^2 l C = .019$ and the bridge should read high by 1.9%. The measured increase of 2.1% is larger because the Type 1409 Capacitor has an internal inductance of about .055 μH , which causes a capacitance increase of about 0.2% at 100 kc. In dissipation factor, the measured D change is .0037 at 100 kc; the calculated $\omega r C$ for $r = .023$ ohms is .0014. Part of the difference is the increase in D of the mica Type 1409 Capacitor at 100 kc, perhaps as much as .001. Some error in D is also contributed by phase shifts that result when the main ratio transformer is loaded by the second transformer connected for ratios of 100 and 1000.

Corrections of the bridge readings of C and D can be made for the major errors produced by the l and r of the transformers on the upper two C MAX ranges. These corrections are tabulated below for typical residual impedances at the bridge terminals to an accuracy of $\pm 10\%$:

C MAX	Subtract from Bridge			
	l μH	r ohm	C Reading ($\omega^2 l C_x$) 19 f ² _{kc} C _{μF} ppm	D Reading ($\omega r C_x$) 140 f _{kc} C _{μF} ppm
0.1 μF	0.48	.023	19 f ² _{kc} C _{μF} ppm	140 f _{kc} C _{μF} ppm
1 μF	0.33	.008	13	50



When leads must be used to connect the capacitor to the bridge terminals, these values of l and r will be increased by the inductance and resistance of the leads. For example, when the leads used in the measurement of a Type 1425-A Decade Capacitor are two copper strips, approximately $7 \times 0.75 \times .016$ inches, the total inductance and resistance on the $1\text{-}\mu\text{F}$ range are increased to $l = 0.48 \mu\text{H}$ and $r = .009 \Omega$.

As an example of error correction, a $1\text{-}\mu\text{F}$ Type 1409-Y Capacitor is measured at 10 kc on the $1\text{-}\mu\text{F}$ C MAX range of the bridge. The C reading is X01596 pF, the D reading is .00 0088 (x10). The C correction is $13 \times (10)^2 \times (1.0) = 1300 \text{ ppm}$ or $1300 \times 10^{-6} \times 1.0 \mu\text{F} = 1300 \text{ pF}$; so the corrected capacitance is X01596 - 1300 = $1.0003 \pm .0001 \mu\text{F}$, if the accuracy of the correction is $\pm 10\%$. The D correction is $50 \times (10) \times (1.0) = 500 \text{ ppm}$; so the corrected D is $880 - 500 = 380 \text{ ppm} = .00038$. The accuracy of the correction is $\pm 10\%$ or $\pm 50 \text{ ppm}$, but the specified accuracy of the bridge reading is only $\pm 0.00001 (1 + f_{kc}) = \pm 110 \text{ ppm}$ even after this correction because of the other errors from winding and stray capacitances.

3.9.7 ERRORS FOR CAPACITANCE LESS THAN 10 PF.

The residual impedances previously described are the chief, but not the only, sources of error with increasing frequency. Another source of error is the voltage induced in the internal bridge wiring connected to the detector circuit by currents flowing in the bridge circuits connected to the transformer. The bridge does not have the short, coaxial current paths required for high-frequency accuracy, and mutual inductances of the order of $0.1 \mu\text{H}$ between bridge arms may result. Since the currents drawn from the transformer by the bridge capacitors increase with frequency ($i = \omega CE$) and the voltages induced in the detector circuit are proportional to ωMi , these error voltages, $e = \omega^2 MCE$, increase with the square of frequency. The errors depend also upon the internal capacitors used and upon the transformer voltages applied to them; hence they are a complicated function of the settings of the bridge decades. Experiments confirm, however, that these errors appear not as a percentage of the measured capacitance but as more-or-less constant picofarad error. The order of magnitude of the error is 0.003 pF or less.

This error can often be seen when the internal capacitance standards are intercompared by use of the 10:1 ratio and the procedure described in paragraph 6.2.5. The measured results on one Type 1615 Bridge are:

Capacitors	1 kc		100 kc	
	C	G	C	G
1000 vs 100 pF	(-1)X0.000	(-1)X0.168	+0.317	
100 vs 10	(-1)X.0 000	(-1)X.0 170	+0.031	
10 vs 1	(-1).X0 000	(-1).X0 430	+0.007	

The 100-kc error of about 0.17% is that produced by a ground-capacitance asymmetry on the 10:1 ratio. The additional error of about .0026 pF in the measurement of 10 vs 1 pF may be attributed to voltages induced in the detector circuit.

3.9.8 ERRORS FROM COMMON IMPEDANCE TO GROUND.

Similar errors that are small fractions of a picofarad or of a few picomhos are produced by common ground impedances in the three-terminal bridge capacitors and in similar external capacitors. The three-terminal capacitor shown in Figure 3-9 has an impedance Z_G between the ground point G of the bridge and the junction

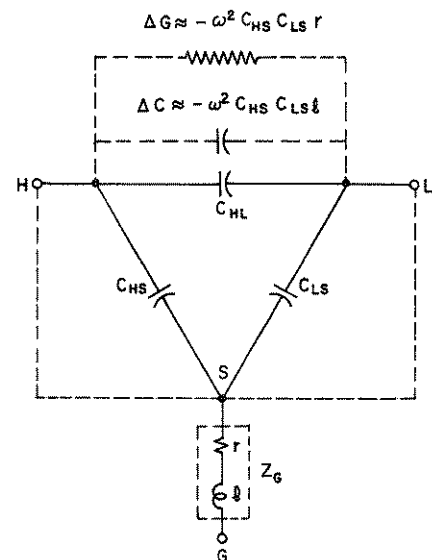

Figure 3-9. Negative G and C errors from common ground impedance, Z_G , in a three-terminal capacitor.

of the two capacitances, C_{HS} and C_{LS} . This impedance Z_G represents, for example, the resistance r and inductance l of a wire used to connect the shield of a three-terminal capacitor to the junction of the bridge ratio arms. The effect of any such impedance common to both C_{HS} and C_{LS} is to subtract from the direct capacitance C_{HL} a capacitance equal to $\omega^2 C_{HS} C_{LS} l$ and a conductance $\omega^2 C_{HS} C_{LS} r$. The error most commonly seen is that of the negative loss, both because it is often larger of the two components and because negative loss in a capacitor is an obvious indication of the presence of error. As a simple example of orders of magnitude, assume $C_{HS} = C_{LS} = 100 \text{ pF}$ and let $r = 0.01 \text{ ohms}$, $l = 0.1 \mu\text{H}$; then at 100 kc the capacitance change is $\Delta C = .0004 \text{ pF}$ and the negative conductance is $\Delta G = .000 04 \mu\text{mho}$. Such errors are usually small, unless the magnitudes of Z_G , C_{HS} , and C_{LS} are considerably increased, as for example, by the use of long cables between capacitor and bridge.

3.9.9 BRIDGE ACCURACY.

The curves in Figures 3-10 and 3-11 indicate the possible errors when no corrections are applied to the bridge readings. Corrections can be used in the regions to the right of the sloped lines on the right-hand end of each curve to reduce the errors from transformer series impedances to approximately the level of the horizontal part of the curve.

The plotted dots show typical variations of error with transformer ratio at 100 kc/s and indicate the reduction in error when the ratio is close to unity; i.e., when the unknown is nearly equal to the internal standard (see paragraph 3.9.4).

The low-frequency limits set by the bridge sensitivity are typical of the Type 1620-A Assembly.

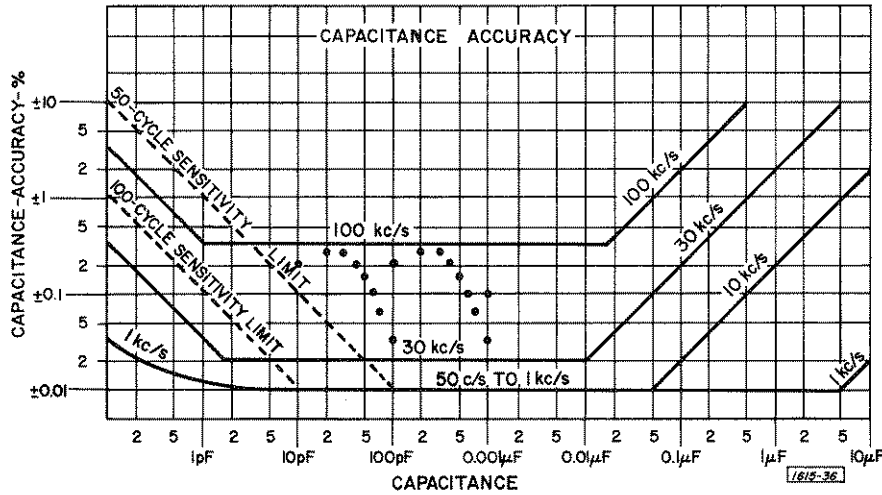

Figure 3-10.

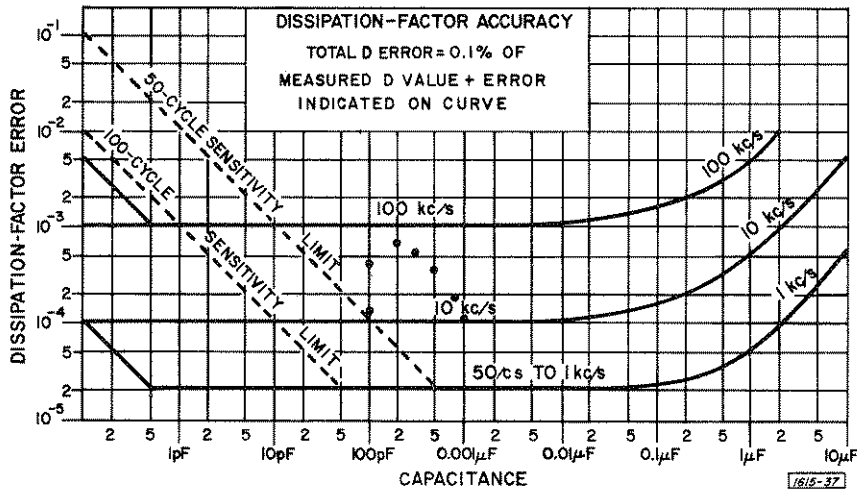
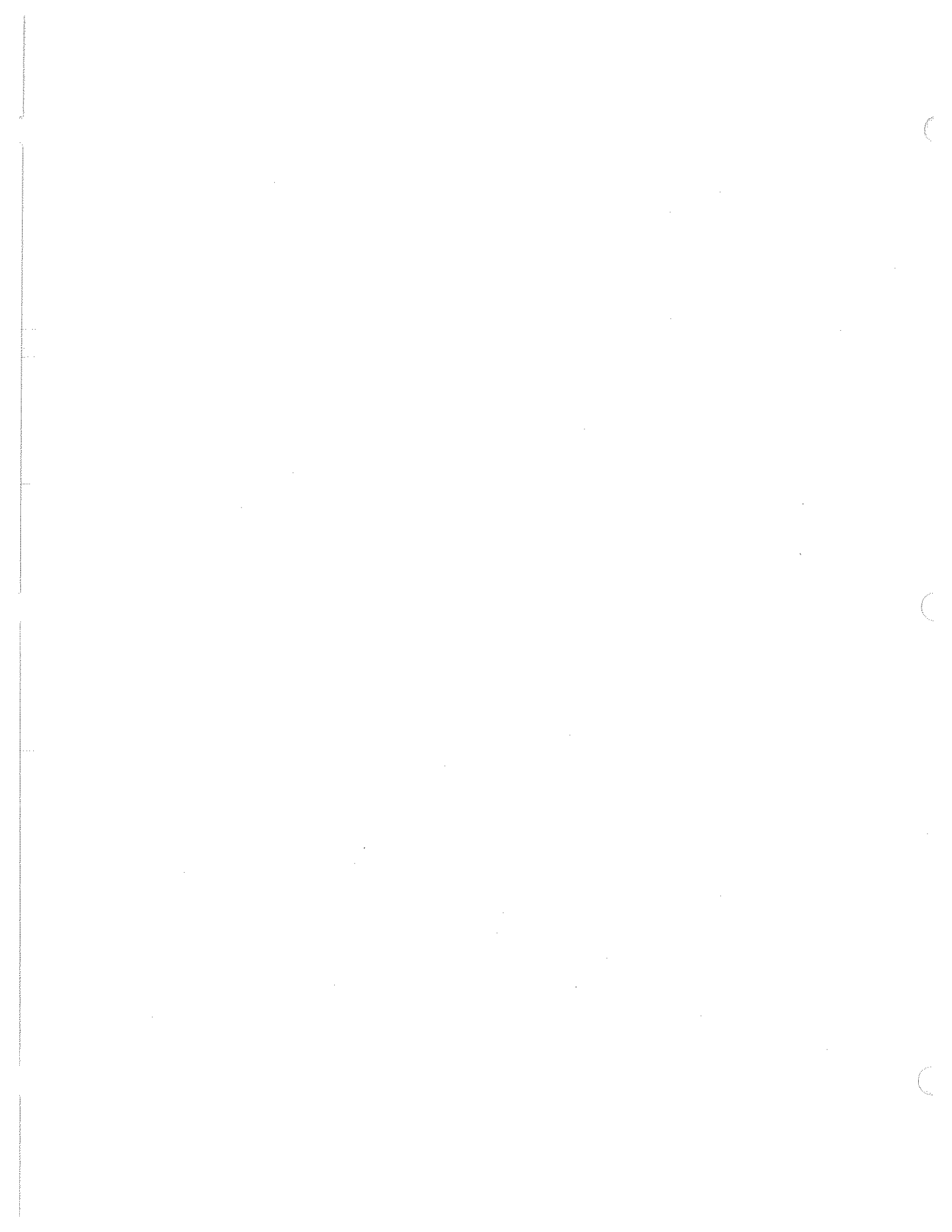

Figure 3-11.



SECTION 4

THEORY OF OPERATION

NOTE

This section is limited to a discussion of the Type 1615-A Capacitance Bridge, as the theories of operation of Types 1311-A and 1232-A are covered in their respective manuals.

4.1 INTRODUCTION.

4.1.1 GENERAL. The Type 1615-A Capacitance Bridge is a standards laboratory instrument designed for accurate precision measurements of capacitance and dielectric properties, and for the intercomparison of capacitance standards over a wide range of values.

4.2 PROPERTIES OF CAPACITORS.

4.2.1 GENERAL. Most physical capacitors can be accurately represented by the three capacitances shown in Figure 4-1: the direct capacitance, C_{HL} , between the terminals H and L (capacitance between the plates of the capacitor), and the two terminal capacitances, C_{HG} and C_{LG} , capacitances from the corresponding terminals and plates to the capacitor case, surrounding objects, and to ground (to which the case is connected either conductively or by its relatively high capacitance to ground).

4.2.2 TWO-TERMINAL AND THREE-TERMINAL CONNECTIONS. In the two-terminal connection, the capacitor has the L and G terminals connected together, i.e.,

the L terminal is connected to the case. The terminal capacitance, C_{LG} , is thus shorted, and the total capacitance is the sum of C_{HL} and C_{HG} . Since one component of the terminal capacitance C_{HG} is the capacitance between the terminal and surrounding objects, the total capacitance can be changed by changes in the environment of the capacitor and particularly by the introduction of the wires required to make connection to the capacitor.

The uncertainties in the calibrated value of a two-terminal capacitor can be of the order of tenths of a picofarad if the geometry, not only of the capacitor plates, but of the environment and of the connections is not defined and specified with sufficient precision. For capacitors of 100 pf and more, the capacitance is usually adequately defined for an accuracy of a few hundredths per cent if the terminals and method of connection used for calibration are specified. For smaller capacitances or for higher accuracy, the two-terminal capacitor is seldom practical and the three-terminal arrangement is preferred.*

A three-terminal capacitor (Figure 4-2) has connected to the G terminal a shield which completely surrounds at least one of the terminals (H), its connecting wires, and its plates except for the area that produces the desired direct capacitance to the other terminal (L). Changes in the environment and the connections can

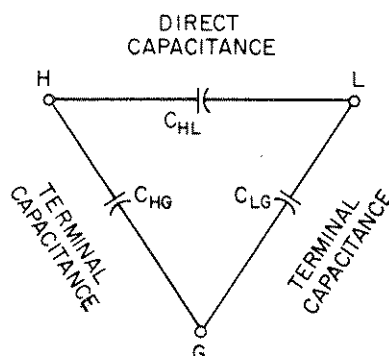

Figure 4-1. Schematic diagram of a capacitor showing the direct capacitance and its associated terminal capacitances.

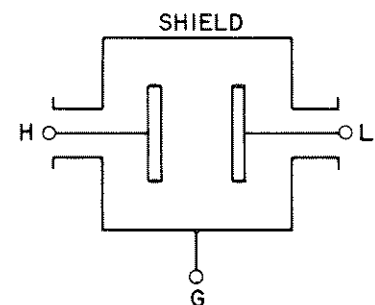

Figure 4-2. Diagram of 3-terminal capacitor.

*John F. Hersh, "A Close Look at Connection Errors in Capacitance Measurements," *General Radio Experimenter*, 33, 7, July, 1959.



vary the terminal capacitances, C_{HG} and C_{LG} , but the direct capacitance C_{HL} — usually referred to simply as the capacitance of the three-terminal capacitor — is determined only by the internal geometry.

This direct capacitance can be calibrated by three-terminal measurement methods, such as guard circuits or transformer-ratio-arm bridges, which exclude the terminal capacitances.

The direct capacitance can be made as small as desired, since the shield between terminals can be complete except for a suitably small aperture. The losses in the direct capacitance can also be made very low because the dielectric losses in the insulating materials can be made a part of the terminal impedances. When the three-terminal capacitor is connected as two-terminal, the two-terminal capacitance will exceed the calibrated three-terminal value (C_{HL}) by at least the terminal capacitance C_{HG} .

4.2.3 FREQUENCY CHARACTERISTICS. Although the characteristics of capacitors sometimes approach the ideal, small deviations from ideal performance must be examined and evaluated for the capacitors to be known with high accuracy. The residual parameters which cause such deviations are shown in the lumped-constant, two-terminal equivalent circuit of Figure 4-3. R represents the metallic resistance in the leads, supports and plates; L , the series inductance of the leads and plates; C , the capacitance between the plates; C_k the capacitance of the supporting structure. The conductance, G , represents the dielectric losses in the supporting insulators, the losses in the air or solid dielectric between capacitor plates and the d-c leakage conductance.

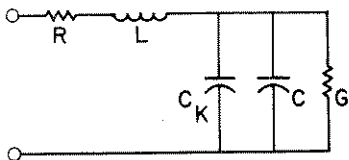

Figure 4-3. The equivalent circuit of a capacitor.

The effective terminal capacitance, C_E , of the capacitor becomes greater than the electrostatic or zero-frequency capacitance, C_0 , as the frequency increases because of the inductance L . When the frequency, f , is well below the resonance frequency f_0 (defined by $\omega_0^2 LC_0 = 1$), the fractional increase in capacitance is approximately

$$\frac{\Delta C}{C_0} \approx \omega^2 LC_0 = \left(\frac{f}{f_0}\right)^2 \quad (4-1)$$

With this information, the increase in capacitance at, for example, a frequency of 1 Mc can be computed with high accuracy from the calibrated value at 1 kc. For small increases, the accuracy may be greater than

that of a measurement at 1 Mc because of the difficulties in determining the measurement errors produced by residuals in the connecting leads outside the capacitor.

The three-terminal capacitor has a similar increase in capacitance produced by inductance. The lowest resonance is determined not solely by the calibrated direct capacitance but also by the terminal capacitances, which may be much larger than the direct capacitances.

When the capacitor has a solid dielectric, such as mica, there is another source of capacitance change with frequency. The capacitance increases at low frequencies as the result of dielectric absorption caused by interfacial polarization in the dielectric. The change in capacitance with frequency of a 1000-pf capacitor with mica dielectric is shown in Figure 4-4. The dotted

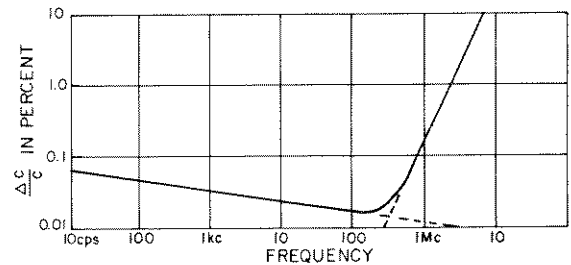

Figure 4-4. Variation of capacitance with frequency.

line slanting downward to the right represents the change in the dielectric constant of mica resulting from interfacial polarization; that slanting upward to the right shows the change in effective capacitance resulting from series inductance. The magnitude of the change at low frequencies depends upon the dielectric material and is, for example, much smaller for polystyrene than for mica.

4.2.4 DISSIPATION FACTOR AND STORAGE FACTOR. An important characteristic of a capacitor is the ratio of resistance to reactance or of conductance to susceptance. This ratio is termed dissipation factor, D , and its reciprocal is storage factor, Q .

$$D = \cot \theta = \frac{R}{X} = \frac{G}{B} = \frac{1}{Q} = \tan \delta \quad (4-2)$$

$$Q = \tan \theta = \frac{X}{R} = \frac{B}{G} = \frac{1}{D} = \cot \delta \quad (4-3)$$

This ratio is defined in Figure 4-5 in terms of phase angle θ and loss angle δ . Dissipation factor is directly proportional to the energy dissipated, and storage factor to the energy stored, per cycle. Power factor is defined as

$$P. F. = \cos \theta = \sin \delta \quad (4-4)$$

and differs from dissipation factor by less than 1% when their values are less than 0.1.

In Figure 4-5, R and X are the series resistance and reactance, and G and B are the parallel conductance and susceptance.

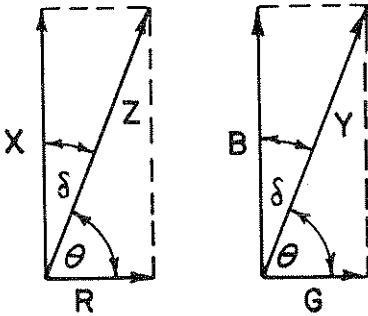

Figure 4-5. Vector diagram showing the relations between factors D and Q, and angles θ and δ .

The dissipation factor of a capacitor is determined by the losses represented in Figure 4-3 by R and G. The resistance R is not usually significant until the frequency is high enough for the skin effect to be essentially complete. At such frequencies the resistance varies as the square root of frequency and may be expressed as $R_1 \sqrt{f}$, where R_1 is the resistance at one megacycle and f is the frequency in megacycles. The total dissipation factor at high frequencies is then

$$D = \frac{G}{\omega C} + R_1 \sqrt{f} \omega C \quad (4-5)$$

At low frequencies only the losses represented by G are important. The leakage conductance component is negligible at frequencies above a few cycles and is important only when the capacitor is used at dc for charge storage. The dominant components at audio frequencies are the dielectric losses in the insulating structure and in the dielectric material between the plates.

In the air capacitor the losses in the air dielectric and on the plate surfaces are negligible under conditions of moderate humidity and temperature. The loss, is, therefore, largely in the insulating supports. When good-quality, low-loss materials, such as quartz, ceramics, and polystyrene are used for insulation, the conductance varies approximately linearly with frequency. The total dissipation factor of an air capacitor, whose equivalent circuit is that of Figure 4-3, may be expressed at low frequencies as

$$D = \frac{G}{\omega(C + C_k)} \quad (4-6)$$

When the capacitance C is variable, this D is then inversely proportional to the total terminal capacitance.

In a capacitor with a solid dielectric the dominant component of the conductance G is the loss in the dielectric, which varies with frequency. The resulting variation of D with frequency, shown for a mica capacitor in Figure 4-6, is the sum of three principal components: a constant dissipation factor caused by residual polarizations and shown by the horizontal dotted line; a loss produced by interfacial polarizations, which contributes the D shown by the dotted line slanting downward to the right; and an ohmic loss in the leads and plates, which results in a D proportional to the 3/2 power of frequency and is shown as the dotted line slanting upward to the right. The total dissipation factor has a minimum value at a frequency which varies inversely with capacitance and which ranges from 1 kc to 1 Mc for capacitance values from 1 μ f to 100 pf.

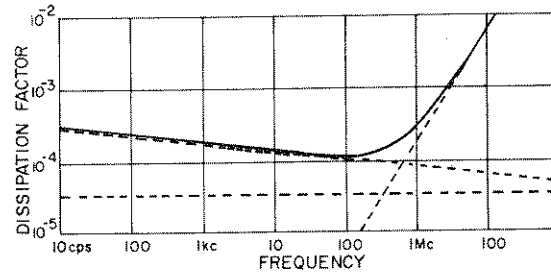

Figure 4-6. Variations of dissipation factor with frequency.

4.2.5 SERIES VS PARALLEL CAPACITANCE. Every capacitance can be expressed in terms of either series or parallel components. The choice is a matter of convenience for the problem at hand. One cannot tell from a single measurement whether a combination of a resistive and a reactive element is actually parallel or series. Regardless of the physical arrangement, the resistive and reactive components can be measured. The series notation is as shown in Figure 4-7a, where C_s is the pure capacitive component and R_s is the series resistance or loss component. The vector diagram for the series equivalent is given in Figure 4-7b, where θ is the phase angle and δ is the dielectric-loss angle.

In the series equivalent case, the dissipation factor, D, defined as the cotangent of the dielectric phase angle, is:

$$D = \cot \theta = \tan \delta = \frac{R_s}{\frac{1}{\omega C_s}} = \omega C_s R_s \quad (4-7)$$

In parallel notation, the equivalent circuit is that of Figure 4-7c, where the resistance, R_p , represents the loss component, G is the conductance, and the capacitance, C_p , is the pure capacitive component. The vector diagram for the equivalent parallel circuit may be represented as in Figure 4-7d, where again θ is the phase angle and δ is the dielectric-loss angle.



Figure 4-7. Series and parallel equivalent circuits of capacitors.

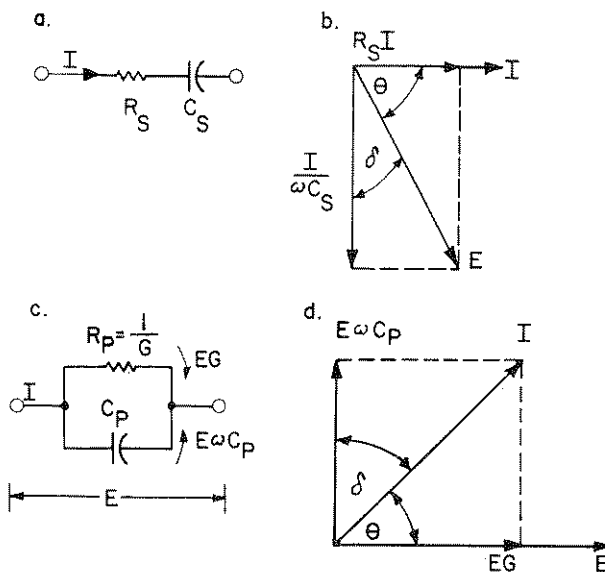

Then, the dissipation factor, D , is:

$$D = \cot \theta = \tan \delta = \frac{G}{\omega C_p} = \frac{1}{\omega C_p R_p} \quad (4-8)$$

The relation of series and parallel equivalent values is:

$$C_p = \frac{C_s}{1 + D^2} = \frac{C_s}{1 + \tan^2 \delta} = C_s \cos^2 \delta \quad (4-9)$$

$$R_p = \frac{R_s(1 + D^2)}{D^2} = \frac{1 + D^2}{D \omega C_s} \quad (4-10)$$

Note that the C values are essentially equal when D is small.

4.3 CAPACITANCE MEASUREMENTS.

4.3.1 GENERAL. Measurements of capacitance, particularly those of high accuracy, are made by a null method which uses some form of the basic ratio bridge, shown in Figure 4-8. The capacitance of the unknown, C_x , is balanced by a calibrated, variable, standard

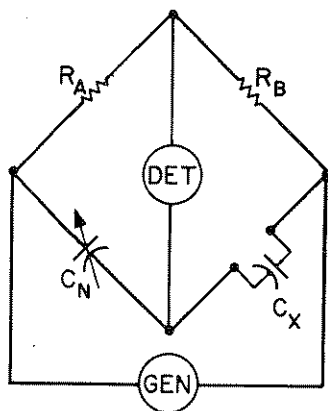

Figure 4-8. Basic ratio bridge.

capacitor, C_N , or by a fixed standard capacitor and a variable ratio arm, such as R_A . Such bridges with resistive ratio arms and with calibrated variable capacitors or resistors can be used over a wide range of both capacitance and frequency and with a direct-reading accuracy which seldom exceeds 0.1%.

For higher accuracy, resolution, and stability in capacitance measurements at audio frequencies, a bridge with inductively-coupled or transformer ratio arms has many advantages, and increasing use of transformer-ratio-arm bridges is being made in the measurement of many types and sizes of capacitors.

4.3.2 TRANSFORMER RATIO ARMS. The advantages of transformer ratio arms in a bridge are that accuracies within a few parts per million are not difficult to obtain over a wide range of integral values, even for ratios as high as 1000 to 1, and that these ratios are almost unaffected by age, temperature, or voltage. The low impedance of the transformer ratio arm also makes it easy to measure direct impedances and to exclude the ground impedances in a three-terminal measurement without the use of guard circuits and auxiliary balances.

To illustrate these characteristics, a simple capacitance bridge with transformer ratio arms is shown in Figure 4-9. On the toroidal core, a primary winding, connected to the generator, serves only to excite the core; the number of primary turns, N_p , determines the load on the generator but does not influence the bridge network. If all the magnetic flux is confined to the core — as it is to a high degree in a symmetrically wound toroid with a high-permeability core — the ratio of the open-circuit voltages induced in the two secondary windings must be exactly equal to the ratio of the number of turns. The ratio can be changed by the use of taps along the two secondaries, but, when the number of turns between taps is fixed, the voltage is highly

invariant. Changes in the core permeability with time and temperature have only very small effects on the ratio, because they modify only the very small amount of leakage flux that is not confined to the core in a practical transformer. The ratio is, therefore, both highly accurate and highly stable.

In Figure 4-9, the two transformer secondary windings are used as the ratio arms of the capacitance bridge with the standard capacitor, C_N , and the unknown, C_X , as the other two arms in a conventional four-arm bridge network. The condition for balance, or zero detector current, is easily shown to be that

$$V_N C_N = V_X C_X \text{ or } \frac{C_X}{C_N} = \frac{V_N}{V_X} = \frac{N_N}{N_X} \quad (4-11)$$

This balance condition is not affected by the capacitances shown from the H and L terminals of C_N and C_X to the terminal G connected to the junction of the ratio arms. The capacitances between L and G shunt the detector, so that they affect only the bridge sensitivity. The capacitances between H and G are across the transformer windings. To the extent that the transformer can be assumed ideal, i.e., with no resistance in the secondary windings and with no flux that does not link equally both secondaries, the current drawn by the H-G capacitances does not change the voltages V_N and V_X or the balance conditions. In practice, the transformer resistances and leakage inductances can be kept so small that quite low impedances or large capacitances can be connected from H to G before there is appreciable error in the bridge.

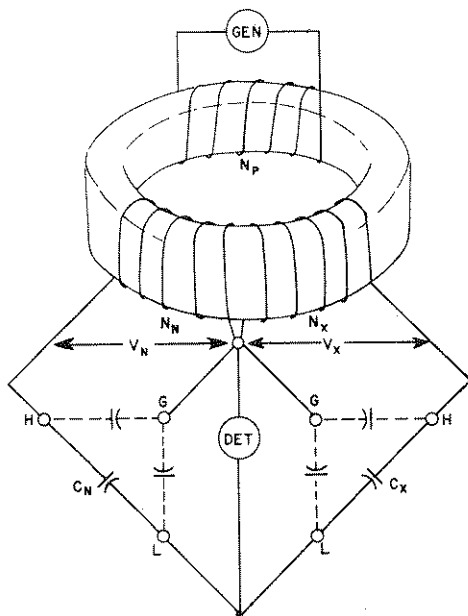

Figure 4-9. A capacitance bridge with transformer ratio arms.

The junction of the ratio arms, G, is therefore a guard point, or guard potential, in the bridge. All capacitances to G from the H or L corners of the bridge are excluded from the measurement. In the three-terminal capacitors represented by the H, L, G terminals in Figure 4-9, the bridge measures only the direct capacitance, C_X , of the unknown in terms of the direct capacitance, C_N , of a standard, without additional guard circuits or balances.

One can take advantage of the accurate and stable ratios of the transformer by the use in the bridge of a standard arm which is fixed and a ratio which can be varied to balance the bridge.

Figure 4-10 shows three of the possible ways of balancing a simple transformer-ratio capacitance bridge. For simplicity, the generator and primary are not shown, but it is assumed that the two secondaries have 100 turns each and are excited so that there is 1 volt per turn. The capacitor in the unknown arm is assumed to be 72 picofarads.

In Figure 4-10a, the two ratio arms are equal and the bridge is balanced in the conventional way with a variable standard capacitor which is adjusted to 72 pf.

The detector current can equally well be adjusted by a variation in the voltage applied to a fixed standard capacitor. In Figure 4-10b, the standard capacitor is fixed at 100 pf, and this is balanced against the 72-pf unknown connected to the 100-volt end of the transformer by connection of the standard to 72 volts of the opposite phase, obtained from suitable taps on the transformer windings. The inductive divider shown has a winding of 100 turns with taps every 10 turns and, on the same core, another winding of 10 turns tapped every turn. If, as shown, the second winding is connected to the 70-volt tap on the first winding and the capacitor to the 2-volt tap on the second winding, the required 72-volts is applied to the capacitor. Six or more decades for high precision can be obtained in a similar fashion with more turns on one core and the use of additional cores driven from the first. Such inductive dividers have very accurate and stable ratios, but the errors increase with the number of decades because of loading effects.

Another method of balance by voltage variation is shown in Figure 4-10c, where a single decade divider is used in combination with multiple fixed capacitors. The 100-turn secondary is tapped every 10 turns to provide 10-volt increments. If, then, a 100-pf capacitor is connected to the 70-volt tap and a 10-pf capacitor to the 20-volt tap, the resulting detector current balances that of the 72-pf unknown connected to 100 volts. This bridge can be given six-figure resolution, for example, through the use of six fixed capacitors in decade steps from 100 pf to 0.001 pf, each of which can be connected to any one of the taps on the transformer.

In any of these bridges, the bridge ratio can also be varied by use of taps on the unknown side of the



TYPE 1615-A CAPACITANCE BRIDGE

transformer to vary the voltage applied to the unknown capacitor. For example, if the unknown capacitor were connected to a 10-turn or 10-volt tap on the upper half of the transformer, then a capacitance of 720 pf instead of 72 would be balanced by the standard capacitors shown. The range of the bridge can thus be extended to measure capacitors which are much larger than the standards in the bridge.

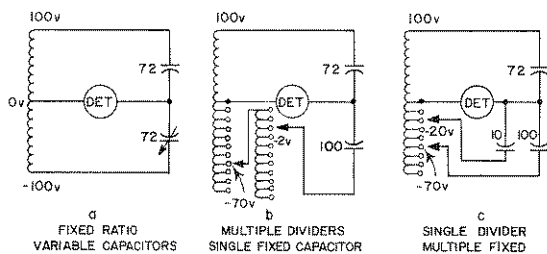

Figure 4-10. Methods of balancing capacitance in a transformer-ratio bridge.

These advantages of transformer ratio arms and dividers make possible a bridge of wide range and high accuracy, since not only are the ratios stable and accurate but, when only a few fixed capacitors are required as standards, the standards can be constructed to have high stability and accuracy. This bridge can also have a wide range of frequencies. At low frequencies, a limit is imposed on sensitivity by the maximum voltage obtainable from the transformer, since, for a given core, the voltage at saturation is proportional to frequency. At high frequencies there is a decrease in accuracy resulting from the decrease in core permeability with frequency, from the increased loading of the transformer by its self-capacitance as well as the bridge capacitances and, of course, from the usual residual capacitances and inductances in the bridge wiring and components.

4.4 THE TYPE 1615-A CAPACITANCE BRIDGE.

4.4.1 GENERAL. The Type 1615-A Capacitance Bridge is a transformer-ratio bridge of the type that uses a single decade of transformer voltage division and multiple, fixed, standard capacitors to provide six decades of resolution in capacitance.

4.4.2 CAPACITANCE MEASUREMENT. As shown in the elementary diagram of Figure 4-11, one side of the secondary of the ratio transformer is tapped at intervals of one-tenth, and to these taps can be connected six standard capacitors in any combination required to balance the bridge. If, for example, the standards connected to the six decade switches are 1000, 100, 10, 1, 0.1, and 0.01 pf, the range of the unknown that can be balanced is from 1000 pf to 0.001 pf when the

unknown is connected to the full voltage of the other secondary of the transformer. This unknown side of the transformer has, however, a tap at one-tenth of the full voltage, so that when the unknown is driven from this lower voltage, the range is multiplied by ten, and an unknown up to 10,000 pf, or 0.01 μf , can be balanced by the same internal standards. The range is extended still further by further division of voltage on the unknown side through a second transformer or inductive divider driven from the 0.1 tap on the ratio transformer. This second divider provides additional ratios of 0.1 and 0.01, so that, with the voltage applied to the unknown reduced to 0.01 and 0.001, the bridge is given two more ranges of 0.1- μf and 1- μf maximum capacitance.

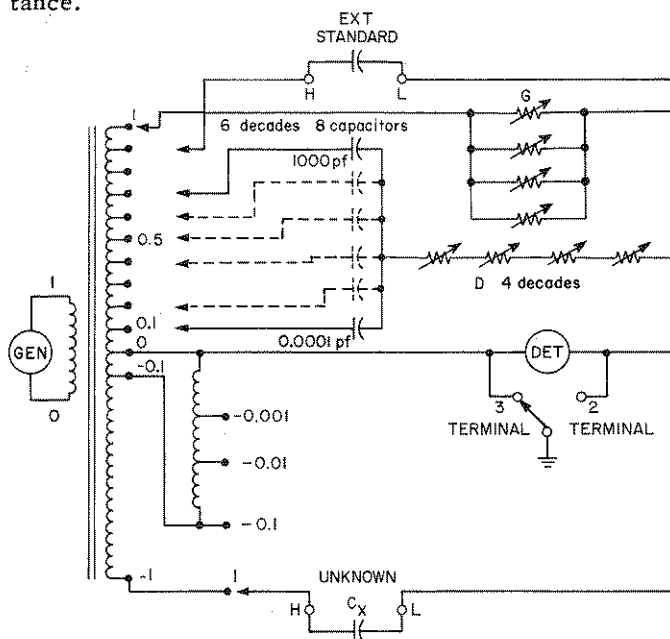

Figure 4-11. Elementary schematic diagram of the Type 1615-A Capacitance Bridge.

To extend the range to smaller capacitances, two additional standards are used, of 0.001 and 0.0001 pf. This yields two more ranges, 0.0001 pf to 100 pf and 0.00001 pf to 10 pf. There are, therefore, eight standard capacitors, only six of which are used for any one range. The necessary standard connections are made by the same range switch that selects the transformer taps.

With this combination of eight internal-standard capacitors and four voltage ratios to which the unknown can be connected, the capacitance range of the bridge extends from a maximum of 1.111,110 μf to a minimum step of 0.00001 pf or 10^{-11} μf . The capacitors and ratios used for each range are indicated in Figure 4-12.

4.4.3 LOSS MEASUREMENTS. To obtain a precision of six figures in the capacitance balance, the loss balance must be made equally precise. As shown in

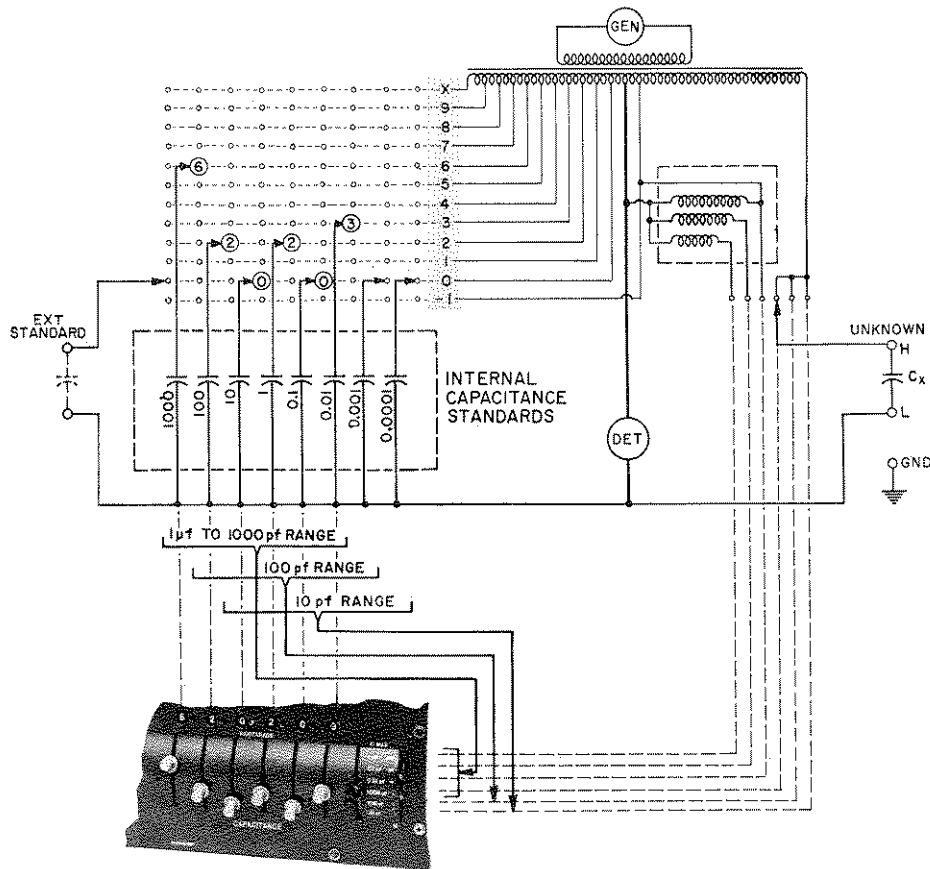

Figure 4-12. Capacitance balance control.

Figure 4-11, the loss balance in this bridge can be made in terms of either the dissipation factor, D , or the shunt conductance, G , of the unknown. For most purposes, dissipation factor offers the greater range and convenience. Conductance is useful in some measurements of dielectric materials and is necessary when external standards are added to the bridge and when the loss in the bridge standards exceeds that of the capacitor being measured.

4.4.3.1 Dissipation Factor. (Figure 4-13). The balance of loss in terms of dissipation factor is made by means of four resistance decades connected in series with the common side of all the internal capacitance standards, as shown in Figure 4-11. Since there is some capacitance from the junction point of capacitors and resistors to the bridge shields, the basic network which provides the effective bridge-dissipation-factor adjustment is the T-network shown in Figure 4-13b. The effective direct impedance of this network between the terminals a and b is

$$Z_{ab} = \frac{1}{j\omega C_N} [1 + j\omega R_N (C_N + C_D)], \quad (4-12)$$

which is equivalent to a capacitance C_N with a dissipation factor

$$D_N = \omega R_N (C_N + C_D). \quad (4-13)$$

Although the effective capacitance, C_N , of the bridge is varied by varying the voltages applied to any of the several bridge capacitors, the total capacitance, $C_N + C_D$, which includes all the direct and stray capacitance connected to the junction of C_N and R_N , remains constant. The resistance of the R_N decades can, therefore, be calibrated to read D directly at a particular frequency, in this bridge at 1000 cps. With four decades of 100, 10, 1, and 0.1 ohms per step and with the total capacitance adjusted to 0.001592 μf , the range of D at 1000 cps is from 0 to 0.01 in 1 ppm steps. The capacitance value of 0.001592 μf is selected to make $2\pi fC = 10^{-5}$, so that R_N can be converted to D_N by a simple shift of decimal point in the read-out.

At other frequencies, the indicated D must be multiplied by the frequency in kilocycles. To extend the range to higher D , additional capacitors are added by a range switch to make $C_T = 0.01592 \mu\text{f}$ for a maxi-

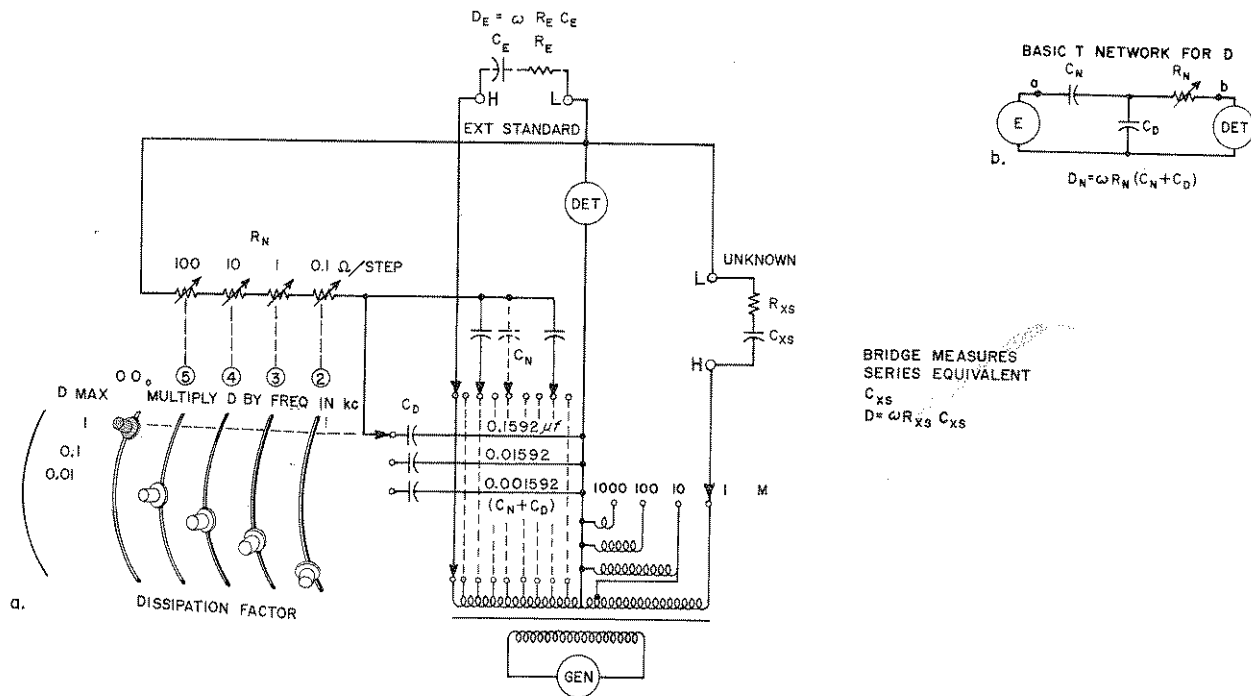

Figure 4-13. Dissipation-factor balance controls.

imum D of 0.1 and to make $C_T = 0.1592 \mu f$ for a maximum D of 1.

The effective direct capacitance C_N is not changed when capacitance is added to C_D to increase the total, $C_N + C_D$, since C_D appears only in the D term in Equation 4-12. Note that the series connection of bridge standard capacitors and resistors means that the capacitance (C_B) and loss (D_B) readings of the bridge on the D ranges measure equivalent series components of the unknown,

$$C_{XS} = C_B \quad (4-14)$$

and

$$R_{XS} = \frac{D_B}{\omega C_B} \quad (4-15)$$

4.4.3.2 External Standards. When an external standard is added to the bridge, a connection of its capacitance parallel to C_N and in series with R_N would change the calibrated total capacitance. The bridge as shown in Figure 4-13, has, therefore, the EXT STANDARD H terminal connected through a decade switch to the transformer taps, the L terminal to the detector. The ten steps of voltage which can be applied to the H terminal divide the external capacitance C_E by the decade steps indicated in the window of the MULTIPLY EXT STANDARD switch, but they do not change the D_E of the external standard. The bridge D decades vary only the dissipation factor of the effective bridge capacitance, indicated by the C_N decades,

and this capacitance with variable loss is in parallel with any external standard used.

The D of the unknown can be determined when an external standard is used on the bridge by calculating the total D of the bridge and external capacitors in parallel, as in the circuit shown in Figure 4-14a. The known components of the impedances are the bridge readings of the internal effective series capacitance C_B and dissipation factor D_B and the series capacitance C_E and dissipation factor D_E of the external capacitor. The total D of this circuit is

$$D_T = \frac{C_B D_B (1 + D_E^2) + C_E D_E (1 + D_B^2)}{C_B (1 + D_E^2) + C_E (1 + D_B^2)} \quad (4-16)$$

and any D is defined as $D = \omega RC$ for series equivalents. The total series capacitance of the circuit is

$$C_{TS} = C_E + C_B - \frac{C_E C_B (D_B - D_E)^2}{C_B (1 + D_E^2) + C_E (1 + D_B^2)} \quad (4-17)$$

The equations can be simplified for small D, where D^2 can be neglected and $1 + D^2 \approx 1$. Then

$$D_T \approx \frac{C_B}{C_B + C_E} D_B + \frac{C_E}{C_B + C_E} D_E \quad (4-18)$$

and

$$C_{TS} \approx C_B + C_E \quad (4-19)$$

From these equations it is easier to see why a very large bridge D_B may be required to balance a small unknown $D_X (=D_T)$ when an external standard is used and why balance with D_B may not be possible on the bridge. As one extreme example, if the external C_E equals the unknown $C_X (=C_T)$, then $C_B = 0$ and D_B can have no effect on D_T . The loss is balanced only if the external standard D_E happens to equal D_X , or adjustment of D_E is provided outside the bridge. If the external standard is only slightly smaller than the unknown, say, $C_E = 0.99 C_X$, then C_B balances the difference capacitance and $C_B = 0.01 C_X$. In this case, $\frac{C_B}{C_B + C_E} = 0.01$, and, if the external standard D_E can be neglected, the bridge D_B must be 100 times the D_X of the unknown.

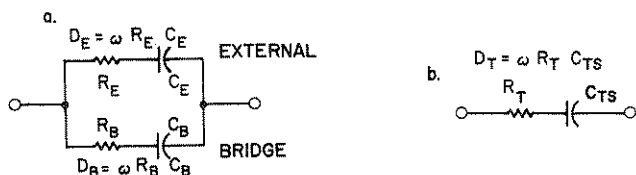

Figure 4-14. Equivalent circuit with external standard for D.

In general, when the bridge capacitance is a small fraction of the total capacitance of bridge and external standard, the bridge D may have to be very large, perhaps beyond the bridge D range. Furthermore, if the external standard D_E exceeds the D_X of the unknown, but the capacitance C_E is smaller than the un-

known, the bridge cannot add loss to the unknown to reach balance. Because the balance and calculation of D are not simple in many cases when external standards are used, loss balance with conductance G is recommended.

4.4.3.3 Conductance: G. (Figure 4-15). It is simple, however, to use the low-resistance decades in the basic T-network for G, shown in Figure 4-15b, to obtain a variable conductance. The relation between the decade resistance R_N and the direct conductance G_{ab} between the terminals a and b is

$$G_{ab} = \frac{R_N}{AB + R_N A + R_N B} = \frac{R_N \times 10^{-10}}{1 + 2 \times 10^{-5} R_N} \quad (4-20)$$

when 100-kilohm fixed resistors are used as the series arms A and B. The four decades of resistance, R_N , then provide a range of G from 0.1 μ mho to 10 pmho. The conductance is reduced by a factor of ten when the network is switched to the 0.1 tap on the transformer (Figure 4-15a) instead of to the full winding, and the range is then from 0.01 to 0.000001 μ mho. When the loss in the standard capacitors, external or internal, exceeds that of the unknown, the bridge must be able to add loss to the unknown. With the conductance balance of loss, the T-network can be readily switched to the taps at full or tenth voltage on the unknown side of the bridge to provide the same two ranges of conductance across the unknown -G as there

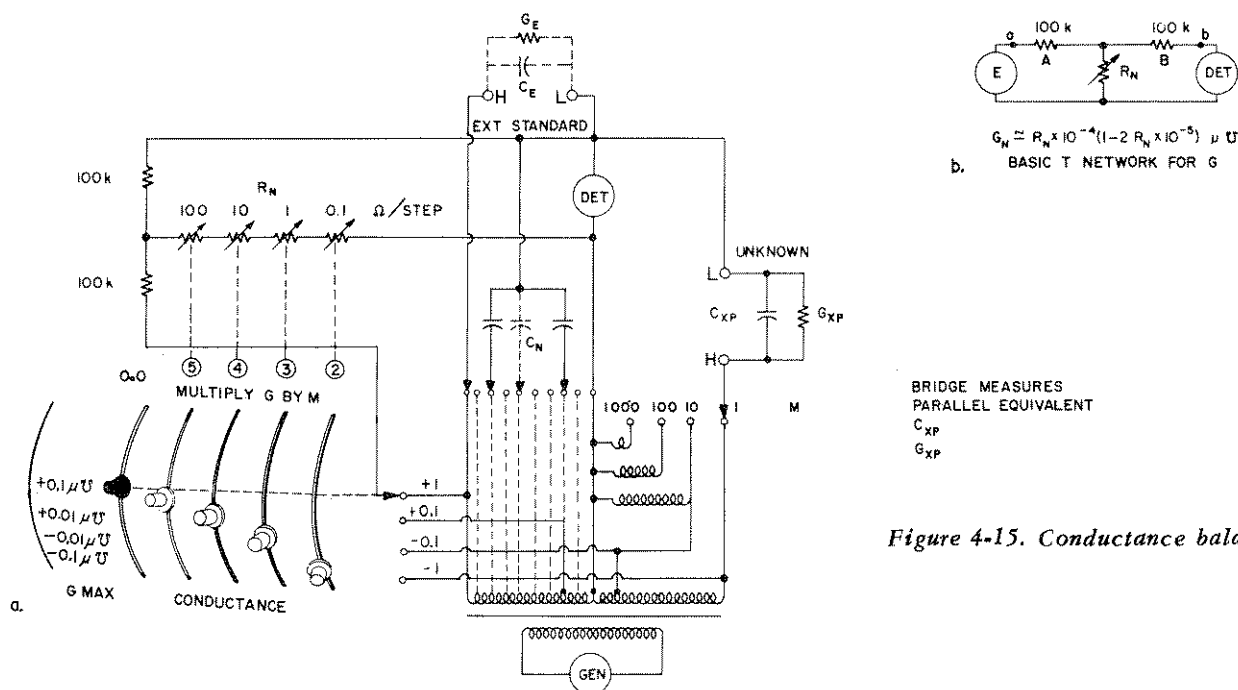

Figure 4-15. Conductance balance controls.



are for conductance across the internal and external standards +G.

The conductance range is also changed when the transformer ratios on the unknown side of the bridge are changed by the C MAX range lever. The reading of the G dials must then be multiplied by the factor M (1, 10, 100, or 1000) engraved on the C MAX scale adjacent to the lever. Since the conductance relations do not involve frequency, no frequency multiplier is required.

Note that the conductance network is connected in parallel with the bridge capacitance standards, (C_N). The capacitance (C_B) and loss (G_B) readings of the bridge on the G ranges therefore measure equivalent parallel components of the unknown, $C_{XP} = C_B$ and $G_{XP} = G_B$.

The bridge will measure not only capacitors with small, or no, conductance but also resistors with small, or no, capacitance. Since the bridge conductances are relatively small, the resistors which can be measured are relatively large. Table 4-1 shows maximum and minimum resistances which can be measured at the unknown terminals.

4.4.3.4 Correction of G Dial Readings. Since the relation between G and R_N in Equation 4-20 is not linear, the G reading of the bridge, which is proportional to R_N , requires some correction when R_N is near maximum. The error is more evident when Equation 4-20 is written in the form

$$G \simeq R_N \times 10^{-10} (1 - 2 \times 10^{-5} R_N + \text{higher order terms}). \quad (4-21)$$

The conductance is, therefore, lower than indicated by the bridge reading of the R_N decades by an amount which is $2 \times 10^{-3} R_N$ percent or $2 \times 10^{-15} R_N^2$ mhos. For a conductance accuracy of 1%, the error is significant only when the first G decade is set above 3, i.e., when R_N is greater than 300 ohms. For example, when the first decade is set at its maximum indication of X, $R_N = 1 \text{ K}\Omega$ and $2 \times 10^{-3} R_N = 2\%$; the effective conductance is 2% less than the bridge reading. Since the error varies with the square of R_N , the corrections are negligible for most G readings, as shown in Figure 3-7.

4.4.3.5 External Standard. The EXT. STANDARD H terminal, connected to the transformer taps through a decade switch, and L terminal, connected to the detector, permit the connection of external capacitance and conductance in parallel with the bridge C and G internal standards, as shown in Figure 4-15a. With the parallel connection of equivalent parallel components, shown in Figure 4-16, the total capacitance and conductance can be found by simple addition of bridge and external C and G. The known components are the bridge readings of effective parallel capacitance C_B and conductance G_B and the parallel capacitance C_E and conductance G_E of the external capacitor. The total conductance is

$$G_T = G_B + G_E, \quad (4-22)$$

and the total capacitance is

$$C_T = C_B + C_E \quad (4-23)$$

TABLE 4-1
RESISTANCE RANGE OF TYPE 1615-A

G Dials $\mu\Omega$	C MAX	M	R_X
0.0X 000 .000 001	10 100 pf 1000	1	10 M Ω 10 ⁶ M Ω
0.0X 000 .000 001	0.01 μf	10	1 M Ω 10 ⁵ M Ω
0.0X 000 .000 001	0.1 μf	100	100 K Ω 10 ⁴ M Ω
0.0X 000 .000 001	1 μf	1000	10 K Ω 10 ³ M Ω

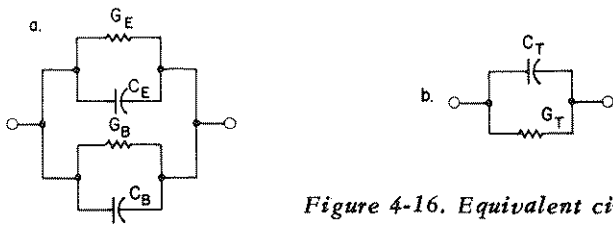

Figure 4-16. Equivalent circuit with external standard for G .

Since the bridge has negative ranges of G and -1 positions on the C levers, the bridge can be balanced with external standards either larger or smaller in C and G than the unknown. The G balance does not depend upon either the sign or relative magnitude of the bridge and external capacitances.

4.5 TYPE 1615-A ACCURACY.

4.5.1 GENERAL. The accuracy of the bridge is determined primarily by the accuracy of the transformer ratios and by the accuracy of the internal standard capacitors. The accuracy of the ratios depends upon the magnitude of the ratio, upon frequency, and upon the load connected to the transformer. The accuracy of the capacitors, which depends initially upon the accuracy of the reference standard with which they are calibrated, is usually limited subsequently by the changes produced by aging and by fluctuations in temperature, pressure, and humidity. To achieve an accuracy of 0.01% in the bridge reading over a wide range of frequency and capacitance and without frequent recalibration, particular care has been taken in the construction of the transformers and capacitors.

4.5.2 RATIO TRANSFORMERS. Relatively low numbers of turns are used in the transformers to keep the leakage inductance, stray capacitance, and resistances of the windings so small that the ratio accuracy remains high, even with loads greater than $1\ \mu\text{f}$ and frequencies above 10 kc. These small residual impedances make it possible, for example, when a 1000-pf capacitor is being measured at 1000 cps with unity ratio, to load the transformer with as much as $1\ \mu\text{f}$ of ground or cable capacitance before the error in the measured direct capacitance exceeds 0.01%. The small bridge inductances are not insignificant, however, when high capacitance is measured at high frequency, and the bridge error is then of the order of $+0.002\% C \mu f \left(\frac{f}{1000}\right)^2$ if no correction for the inductance is used.

The accuracy of the ratios when the transformer is lightly loaded is better than 0.1 part per million for the unity ratio and is better than 2 ppm for the 0.1 ratio at 1000 cps or lower frequencies. The winding self-capacitances act as a load as frequency increases, so that the error in the 0.1 ratio increases to about 20 ppm

at 10 kc and to 0.2% at 100 kc. When the auxiliary transformer is connected for ratios of 0.01 and 0.001, the ratio errors are increased by the loading effects of the input impedance of the auxiliary transformer. These errors are eliminated by compensating resistors, R247 and R248, and the 0.01 and 0.001 ratios in the bridge are adjusted to within ± 20 ppm in the frequency range below 10 kc. The phase errors are, in general, somewhat larger than the magnitude errors of the ratios. At 1000 cps, the phase error is probably within ± 10 μ radians, but the error increases in approximate proportion to ratio and to the square of frequency.

4.5.3 CAPACITANCE STANDARDS. The bridge can be calibrated quickly and accurately by the measurement of a single calibrated external standard capacitor of almost any size within the range of the bridge. Since the six-figure resolution of the bridge permits comparison with a precision better than 0.01% down to 1 pf, the accuracy of calibration is usually determined by the accuracy of the standard. Only one external standard, most conveniently a three-terminal 1000-pf standard such as the General Radio Type 1404-A, is required because the accurate, internal 0.1 transformer ratio can be used to insure an accurate ratio of the internal capacitance standards. A -1 position on each capacitance balance switch connects the corresponding internal capacitor to the 0.1 tap on the unknown side of the transformer. This capacitor can be compared with the next lower decade capacitor, which is connected to the maximum voltage on the standard side when the adjacent lever is set on the X position, and any adjustments required can be made with trimmers accessible beneath a sliding cover on the bridge front panel.

Such checks or recalibrations of the bridge need not be made often. The capacitors are constructed to have such small changes with time, temperature, and environment that the initial calibration to $\pm 0.01\%$ may be expected to change less than 0.01% per year in normal use. The temperature coefficients of the 1000-, 100-, and 10-pf units, which are multiple-plate capacitors, are less than 5 ppm/ $^{\circ}\text{C}$; the coefficients of the Zichner-type 1-, 0.1-, and 0.01-pf units and of the cylindrical 0.001- and 0.0001-pf units are less than 20 ppm/ $^{\circ}\text{C}$.

For almost zero changes of capacitance with atmospheric pressure and humidity, all but the two smallest capacitors are hermetically sealed in an atmosphere of dry nitrogen. This sealing is necessary where stability of better than 0.01% is expected, because in an unsealed capacitor the capacitance changes about 2 ppm for each 1% change in relative humidity; hence a 50% change in humidity produces a 0.01% change in capacitance. And the pressure change, for example, resulting from moving the capacitor from the near-sea-level altitude of Washington, D.C. to the more



than 5000-ft altitude of Boulder, Colorado, produces a capacitance decrease of about 0.01%.

To minimize long-term drift, the capacitor plates are constructed of a single metal (Invar) to avoid differential stresses, and they are annealed and temperature-cycled to relieve strains and to accelerate the initial aging.

4.5.4 RESISTANCE DECADES. Although the accuracy of the measurement of loss is not important in the measurement of many capacitors, the Type 1615-A Capacitance Bridge makes possible measurements of dissipation factor to an accuracy of $\pm(0.1\% + 10 \text{ ppm})$ of the measured value. This accuracy is applicable over the D range from 1 to 0.000001 and over almost the whole capacitance range from 1 μf to 1 pf and the frequency range from 50 cycles to 10 kc. At low frequencies and small capacitance the accuracy will be limited by the reduced sensitivity of the bridge. At high frequencies and at ratios other than unity, the phase errors of the transformers will reduce the accuracy. Within these extremes, the accuracy of the D reading is determined by the resistance decades, which are adjusted within $\pm 0.05\%$, and by the total capacitance connected to the decades, which is trimmed to adjust the D reading to within $\pm 0.1\%$ when a standard of known D is measured.

The loss measurement in terms of shunt conductance G, is limited to an accuracy of $\pm(1\% + 0.00001 \mu\text{mho})$ by the accuracy of the 100-kilohm resistors used in the T-network. Higher accuracy is seldom needed. It would not only add to the cost but would also require corrections to the bridge G reading. These corrections, amounting to a maximum of 2%, are due to the non-linear relation between the decade resistance and the equivalent conductance of the network.

The loss measured by the bridge as either D or G is the loss of the unknown capacitor relative to the loss of the internal standards. Since the bridge capacitors are carefully cleaned and sealed in dry nitrogen, it is estimated that their dissipation factor does not exceed a few parts per million. The accuracy of absolute loss measured by the bridge is, therefore, the same as that of the loss relative to the bridge capacitors.

The four resistance decades (R201-R240) used in conductance and dissipation-factor measurements are wire-wound resistance elements designed to minimize inductance in low-resistance values and to minimize capacitance for high values of resistance. All units up through 100 ohms utilize a so-called Ayrton-Perry winding, in which each resistor consists of two parallel windings of opposed direction, so that the current flow in the two windings is in opposite directions. The external magnetic field, as a result, is effectively canceled so that, typically, the residual inductance of such a winding is of the order of 1% of the inductance of a corresponding single winding.

Elements having 200 ohms resistance or higher are unifilar-wound on their flat rectangular "cards." The inherent phase angle of these resistors is substantially lower than that obtained with so-called "non-inductive" spool-wound resistors.

4.6 CONTROLS AND INDICATORS. (Refer to Table 1-1).

The moderate size and weight of Type 1615-A Capacitance Bridge permit it to be moved about the laboratory with ease, and the bridge is sufficiently rugged to be transported into the field should its accuracy be required there. It is easy to balance, easy to read, and the reading is accurate without corrections.

A feature which contributes much to the ease of balance and of reading is the use of lever, or linear, rather than rotary controls on the switches for the decades. The small panel space occupied by these controls makes it possible to position the six decades and range switch for capacitance and the four decades and range switch for loss within the span of the operator's right and left hands, respectively. The throw of the switches is about three inches, so the 12-position range of any decade can be covered with only a slight motion of hand or finger.

The position of each decade is indicated by a number appearing in the window above each balance control. The bridge capacitance readout thus appears in the form of six closely-spaced digits in a horizontal line and the D or G readout as a similar line of four digits. As S112 is moved to change capacitance range, the decimal point is automatically positioned in the six-figure readout to indicate without multipliers the capacitance in picofarads from a maximum of 1, 111, 110 pf to a minimum of 0.00001 pf. S101 similarly moves the decimal point when the D range is changed to indicate directly the dissipation factor. The decimal point is also positioned automatically to read conductance in micromhos, but since G must be multiplied by the factor M, this factor is indicated in red engraving adjacent to each position of the C MAX range switch lever. This multiplier is required only for G and for external standards, and the color is used on the panel to indicate all quantities to which M must be applied.

When even the approximate magnitude of a capacitor is not known, the initial balance can be found quickly on this bridge by the use of the maximum capacitance range, so that the six decades cover the range from 1 μf to 1 pf and the six controls can be tried in quick succession to determine the balance point without a change in range. The -1 position on each of the capacitance decades, which was mentioned above as useful in the self-calibration of the bridge, also facilitates balance in the region near any zero by permitting a trial reduction of bridge capacitance by one step in a decade without the necessity of moving the adjacent lever.

4.7 CONNECTION OF UNKNOWN.

4.7.1 GENERAL. Two types of connector for the unknown capacitors are provided at the upper right corner of the bridge panel: a pair of Type 874 Coaxial Connectors and a set of three Type 938 Binding Posts with standard 3/4-inch spacing. For three-terminal measurements with complete shielding, as is required particularly for very small capacitance, three-terminal capacitors, such as the Type 1403 and 1404-A Standard Air Capacitors and Type 1422-CD Precision Capacitor, can be connected with coaxial cables to the coaxial bridge terminals. Capacitors having other common types of coaxial connectors can also be connected to the bridge terminals by the use of the appropriate Type 874-Q Adaptor. Capacitors, such as the Type 1401 and Type 1409 Standard Capacitors, which have Type 274 Plugs as terminals, can be plugged into the jack-top binding posts. The binding posts can also be used for the connection of patch cords and leads of many types.

The appropriate set of unknown terminals is connected to the bridge (and the unused terminals disconnected) by means of a four-position terminal selector switch (S113) located next to these terminals. As this switch is moved to change terminals, it also shows the corresponding changes of connections and grounds in the simple equivalent circuit which is engraved on the panel. The resulting circuit diagrams are shown in Figure 4-17.

4.7.2 CALIBRATION. When the terminal switch is set in the position marked CAL, the L sides of all the terminals are disconnected. This permits a self-check or -calibration of the bridge capacitors at any time without the need for disconnecting any unknown.

4.7.3 THREE-TERMINAL MEASUREMENT. In the next position, marked 3 TERM, the coaxial Type 874 UNKNOWN terminals are connected to the bridge, with the L terminal connected to the detector and the H terminal to the transformer. The shields of the connectors and all ground points on the bridge are connected to the guard point, so that all capacitances to the shields or

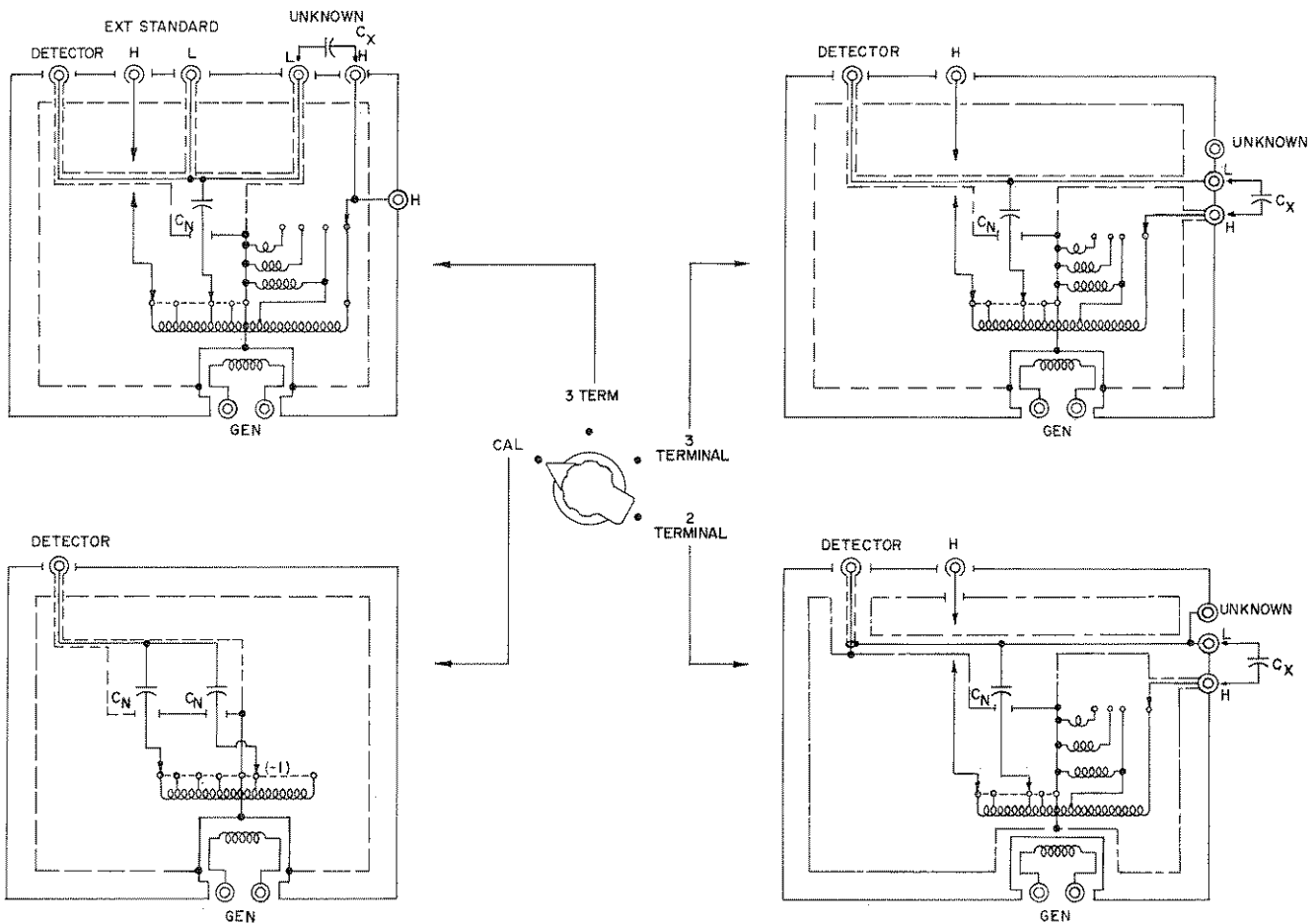

Figure 4-17. Terminal selections of Type 1615-A.



to ground are excluded from the direct capacitance between H and L measured by the bridge.

The third position of the switch, marked 3 TERMINAL, connects to the bridge the H, L, and GND binding posts instead of the coaxial terminals. The H post is connected to the transformer, the L post to the detector, and the GND post to the transformer mid-point and bridge ground. As in the coaxial three-terminal measurement, the bridge measures only the direct capacitance between the H and L posts and excludes capacitances from H or L to any GND or guard point. The open binding posts have a direct capacitance of about 0.2 pf, which must usually be measured and subtracted from the value measured when a capacitor is connected. The bridge can, of course, measure this small terminal capacitance, as well as that of any leads connected between terminals and capacitor.

4.7.4 TWO-TERMINAL MEASUREMENT. The fourth position of the switch, marked 2 TERMINAL, deserves special attention because of the important changes it makes in bridge connections and bridge measurements. The bridge is again connected to the binding-post terminals with the H post connected to the transformer, but the L and GND posts are now connected together and to the bridge case and panel and to any external ground used. The bridge now measures all capacitances between the H terminal and L or GND, including stray capacitances from posts and leads to the panel and other environment.

In principle, this change of the inherently three-terminal transformer bridge to two-terminal operation is made as shown in Figure 4-11; the ground point is simply switched from the center of the transformer arms to the junction of the standard and unknown capacitors, thereby grounding one side of the unknown. In practice, this change is complicated by the fact that the center of the transformer, which is the guard point to which the bridge shields are connected, is then connected to the high-impedance side of the detector instead of to ground. To prevent error voltages from entering the detector, all the wires and bridge shields connected to the high side of the detector must be enclosed by a grounded shield. To provide this extra shielding for two terminal measurements, the bridge components are enclosed in an inner shield box which is enclosed by, but insulated from, the outer box and panel, and the primary of the main ratio transformer is also enclosed in two separate shields.

4.8 EXTERNAL STANDARDS.

4.8.1 RANGE EXTENSION. The usefulness of the bridge is further increased by the provision on the bridge panel of a pair of terminals to permit the connection of an external standard capacitor, or resistor, to supplement or replace the standards in the bridge.

This pair of coaxial Type 874 Connectors, located to the left of the coaxial pair for the unknown, has the L terminal connected to the L terminal of the unknown and the H terminal connected to the standard side of the transformer through a rotary switch, S114, by means of which any of the tens steps of voltage from the transformer can be applied to the external standard. This rotary switch, with its digital readout through a window, provides a seventh decade of capacitance, or a fifth of conductance, whose magnitude is determined by the external standard chosen. For example, the capacitance range can be extended to 11 μf by the connection of an external standard of 0.01 μf (Type 1615-P1). With the C MAX range switch (S112) set at the 1 μf maximum, the rotary decade then provides a balance control of 1 μf per step and the balance controls extend the range six more decades from 0.1 μf through 1 pf per step.

4.8.2 ACCURACY EXTENSION. Since both the unknown and external standard capacitors can be connected to a wide range of accurate transformer ratios, a comparison of external capacitors can be made with an accuracy even higher than that of the direct bridge reading; and the ratios can be chosen so that the magnitudes of the external capacitors do not have to be decade multiples. For example, the Type 1404-A standard capacitor (1000 pf) has a calibration accuracy higher than 0.01% which can be transferred to a capacitor of, say, 5000 pf by connecting that capacitor to the appropriate unknown terminals and the Type 1404-A to the external standard terminals. When the rotary decade switch for the external standard is set to 0.5 and the C MAX lever to the 0.01- μf position (where M = 10), the external standard is effectively multiplied by 5 to balance the unknown. Small differences between the external capacitors can, of course, be balanced with the internal standard capacitance and conductance decades, and any small errors in the bridge reading of the difference are insignificant in the comparison measurement as long as the difference is a small percentage of the total capacitance.

4.8.3 RESOLUTION EXTENSION. The resolution, as well as the accuracy, of the bridge can be extended by the use of an external standard capacitor. It has already been noted above that the external standard and its decade switch S114 add a seventh decade, which can have increments either larger or smaller than those of the six balance control decades. Even higher resolution is possible when, for example, two 1000-pf external capacitors are compared, because the bridge decades can be used to measure a difference as small as 0.00001 pf or 1 part in 10^8 in this example. Usable resolution of 0.1 ppm is not hard to obtain with the recommended Type 1232-A Null Detector, but higher resolution usually requires special detectors.

SECTION 5

SPECIAL MEASUREMENTS

5.1 GENERAL.

The Type 1615-A Capacitance Bridge is a precision instrument of considerable versatility. The contents of this section describe measurement procedures that are less usual and routine than those given in Section 3. Five applications of external standards to increase the range, resolution, accuracy, and flexibility of operation of the bridge are given. In addition, coverage is supplied on methods of extending three-terminal measurement advantages to two-terminal capacitors.

5.2 USE WITH EXTERNAL STANDARDS.

5.2.1 GENERAL. External standards of capacitance or conductance can be connected in parallel with the internal bridge standards at the EXT STANDARD coaxial H and L terminals. The H terminal is connected to the standard side of the ratio transformer through a rotary switch, by means of which any of the ten steps of voltage from the transformer can be applied to the external standard. This switch, MULTIPLY EXT STANDARD BY. . ., with its digital readout through a window, provides a seventh decade of capacitance or a fifth of conductance, whose magnitude is determined by the external standard chosen.

Operating procedures are given below for these principal uses of external standards:

1. Range extension to 11 μf .
2. Range extension above 11 μf .
3. Resolution extension to a seventh decade of capacitance or a fifth decade of conductance.
4. Comparison of external capacitors.
5. Balance of terminal and lead capacitances.

5.2.2 RANGE EXTENSION TO 11 μF . The Type 1615-P1 Range-Extension Capacitor is available as a convenient accessory to extend the range of the instrument to 11 μF . Procedures for using it appear in the Appendix. Other 0.01- μF capacitors, such as the Type 1409-L, may be also applied by use of the Type 1615-P1 procedures.

5.2.3 RANGE EXTENSION ABOVE 11 μf . External capacitance decades of 0.001, 0.01, and 0.1 μf per step, when multiplied by the 1000:1-transformer ratio of the bridge, can serve as bridge decades of 1, 10, and 100 μf per step to extend the capacitance range up to 1000 μf . The following General Radio capacitors are recommended (appendix contains complete specifications):

Type 1423-A Precision Decade Capacitor for $\pm 0.05\%$ decade accuracy.

Type 1419-K Decade Capacitor for $\pm 0.5\%$ decade accuracy.

Type 1419-A Decade Capacitor for $\pm 1\%$ decade accuracy.

The accuracy of measurement of large capacitance is usually limited by the bridge and lead inductance in series with the capacitance. The bridge reading of capacitance is greater than the unknown capacitance C by a capacitance error $\Delta C = \omega^2 C^2 L$. The bridge inductance of about 0.3 μh , in series with the UNKNOWN terminals, results in a minimum error of the order of $+0.002\% C_{\mu\text{f}} (f_{\text{kc}})^2$. Hence, at 1000 cps and 100 μf , the bridge reading is high by about 0.2%.

Additional loss range can be provided by using external resistance decades in parallel with the external capacitance decades. Maximum bridge decade conductance is 0.1 μmho , which is equivalent to an external standard resistance of 10 megohms. For continuous loss balance above the range of bridge decades, use external decades starting at 1 megohm per step and continuing as required to lower resistance (higher conductance).

5.2.3.1 Balance Procedures. The procedures are as follows:

- a. Connect the two-terminal external decade capacitor and resistor H terminal to the bridge coaxial EXT STANDARD H terminal and L (and G) terminals to the bridge L (or GND) terminal. (Use Type 874-Q2 Adaptor to convert the coaxial bridge EXT STANDARD terminal to binding posts, or use Type 874-Q9 Adaptor



to convert the capacitor binding posts to a coaxial terminal.)

- b. Set terminal selector to 2 TERMINAL.
- c. Connect unknown (refer to para. 3.7.5).
- d. Set MULTIPLY EXT STANDARD BY. . . to 1.
- e. Set C MAX to 1 μ f.
- f. Balance capacitance with external decades and bridge CAPACITANCE decades.
- g. Balance loss with external R decades, bridge CONDUCTANCE decades, and appropriate G MAX setting.
- h. Calculate external standard conductance in μ hos.
Example: $G_{EXT} (\mu\text{hos}) = 10^6/R_{EXT}(\text{ohms})$
- i. Multiply G_{EXT} by reading of MULTIPLY EXT STANDARD BY. . . switch.
- j. Add product to reading of bridge CONDUCTANCE decades in μ hos, with indicated decimal point.
- k. Multiply the sum by M (1000 with C MAX set at 1 μ f).

5.2.3.2 Refinement of Capacitance Reading. To determine capacitance of the unknown in pf:

- a. Determine total external standard capacitance of decades plus terminals, adaptors, and connecting cables (refer to para 5.2.3.3).
- b. Multiply total external capacitance in pf by reading of MULTIPLY EXT STANDARD BY. . . switch (set at 1) and by M (1000 with C MAX at 1 μ f).
- c. Add reading of bridge CAPACITANCE decades in pf, with indicated decimal point.
- d. Divide by 10^6 to obtain unknown capacitance in μ f.
- e. To read bridge directly in μ f, decimal point is placed before first figure of bridge CAPACITANCE readout and:

- External decade of 0.1 μ f per step reads 100 μ f per step
- External decade of 0.01 μ f per step reads 10 μ f per step
- External decade of 0.001 μ f per step reads 1 μ f per step
- First bridge decade reads 0.1 μ f per step
- Second bridge decade reads 0.01 μ f per step

NOTE

The corrections for lead and terminal capacitance in the external decades may be equivalent to one or more steps in the first bridge decade, i.e., to tenths μ f in the unknown.

5.2.3.3 Measurement of Terminal and Cable Capacitance. To measure capacitance of terminals, adaptors, and cables:

- a. Remove unknown from bridge terminals.
- b. Set terminal selector to 2 TERMINAL.
- c. Set MULTIPLY EXT STANDARD BY. . . to 0.
- d. Set C MAX switch to 1 μ f.

e. Balance bridge; CAPACITANCE decades should read 000 001. This can usually be assumed within a few pf without measurement.

f. Set external decades to 0 or to minimum capacitance.

g. Switch MULTIPLY EXT STANDARD BY. . . to 0.1.

h. Set first CAPACITANCE decade to -1.

i. Balance bridge with other CAPACITANCE decades and with CONDUCTANCE decades.

j. Calculate external capacitance from

$$C_{EXT} \times 0.1 \times (M = 1000) + C_B = C_X$$

Example: Type 1419-B decade attached to EXT STANDARD terminals (with Type 874-Q9 Adaptor and Type 874-R22A Patch Cord). With open UNKNOWN terminals and EXT STANDARD terminals disconnected (internally), bridge reads 000 001. pf. With Type 1419-B decades set at 0 and connected to bridge, bridge reads (-1)85 144. pf.

$$C_{EXT} \times 0.1 \times 1000 = 000\ 001 - (-100\ 000 + 085\ 144) \\ = 014\ 857$$

$$C_{EXT} = 148.57\ \text{pf}$$

k. Add this lead and terminal capacitance to any reading of the external decades to obtain the total external standard capacitance.

5.2.4 RESOLUTION EXTENSION. When higher bridge resolution of capacitance or loss is required for measurement of very small changes, an external standard can be added to the bridge to provide a seventh decade of capacitance or a fifth decade of conductance.

5.2.4.1 Capacitance. The value of capacitance to be connected to the bridge as an external standard to provide a seventh decade above or below the six bridge decades is shown in Table 5-1. The decade adjustment is provided by the MULTIPLY EXT STANDARD BY. . . switch, which has a digital readout of 0, 0.1, . . . , 0.9, 1. When these steps of the added decade are read as 0, 1, . . . , 9, 10, the corresponding picofarads-per-decade steps are those shown in the two EXT columns to the left and right of the six bridge decades, with the appropriate decimal point shown.

Example: With C MAX at 1000 pf and a 0.001-pf capacitor connected as an external standard, the MULTIPLY EXT STANDARD BY. . . switch provides a seventh decade below the sixth lever and extends the bridge resolution to 0.0001 pf per step for capacitance as high as 1000 pf.

Use a three-terminal capacitor for the external standard. When the external capacitor provides the first figure in a balance to seven-figure resolution, it must have correspondingly high stability. For such stability, use

TABLE 5-1
CAPACITANCE RESOLUTION EXTENSION

C MAX SETTING	EXT STANDARD CAPACITANCE		CAPACITANCE READING in pf with all decades set at 1**						EXT STANDARD CAPACITANCE	
	for 7th Decade above Bridge		E* X T	6 Bridge Decades				E* X T	for 7th Decade below Bridge	
1 μ f	10,000 pf		1	1	1	1	1	1	1	.001 pf
0.1 μ f	10,000 pf		1	1	1	1	1	1	1	.001 pf
0.01 μ f	10,000 pf		1	1	1	1	1	1	1	.001 pf
1000 pf	10,000 pf		1	1	1	1	1	1	1	.001 pf
100 pf	1,000 pf		1	1	1	1	1	1	1	.000 1 pf
10 pf	100 pf		1	1	1	1	1	1	1	.000 01 pf

* Reading of 0.1 in window of MULTIPLY EXT STANDBY BY . . . switch.

** Each individually can be any number from 0-9.

a sealed capacitor with a low temperature coefficient, preferably equivalent to the bridge standards. When the external capacitor provides the seventh figure, the capacitance is very small. High stability and accuracy are not required in the capacitor of this last decade.

Capacitors recommended as external standards are:

- 10,000 pf - Type 1615-P1 Range-Extension Capacitor
- 1,000 pf - Type 1404-A Reference Standard Capacitor
- 100 pf - Type 1404-B Reference Standard Capacitor
- 0.001 pf - Type 1403-V Standard Air Capacitor

The procedures are as follows:

a. Select capacitor on the basis of the above.

b. Measure capacitance of external standard by procedure described in para. 3.7.2.

c. Move the external standard capacitor to the bridge H and L coaxial EXT STANDARD terminals.

d. Connect unknown and balance bridge.

5.2.4.2 Conductance. The value of conductance to be connected to the bridge as an external standard to provide a fifth decade above or below the four bridge decades is shown in Table 5-2. The decade adjustment is provided by the MULTIPLY EXT STANDARD BY. . . switch, which has a digital readout of 0, 0.1, . . . , 0.9, 1. When these steps of the added decade are read as 0, 1, . . . , 9, 10, the corresponding micromhos per step are shown in the EXT columns to the left and right of the four bridge decades, with the appropriate decimal point shown in the line of digits.

TABLE 5-2
CONDUCTANCE RESOLUTION EXTENSION

G MAX SETTING	EXT STANDARD for 5th Decade above bridge			CONDUCTANCE READING in μ U with all decades set at 1						EXT STANDARD for 5th Decade below bridge	
	G	R	E* X T	4 Bridge Decades				E* X T	G	R _T **	
+0.1 μ U	1 μ U	1 M Ω	0.	1	1	1	1	1	1	10 pU	10 Ω
+0.01 μ U	0.1 μ U	10 M Ω	.0	1	1	1	1	1	1	1 pU	1 Ω

* Reading of 0.1 in window of MULTIPLY EXT STANDARD BY. . . switch.

** See Figure 5.1 for use of R_T in T network.



Example: With G MAX at $+0.1 \mu\Omega$ and a resistor of 1 megohm (equivalent to a conductance of $1 \mu\Omega$) connected as an external standard, the MULTIPLY EXT STANDARD BY . . . switch provides a fifth decade above the first bridge decade with a conductance of $0.1 \mu\Omega$ per step. The maximum unknown conductance which can be balanced is then $1 \mu\Omega$ multiplied by the factor M corresponding to the C MAX position used.

For a standard of 1 or $0.1 \mu\Omega$, use a deposited-carbon or metal-film resistor of 1 or 10 megohms with an accuracy of $\pm 1\%$. Mount the resistor in a shield to reduce the capacitance across it and the noise pickup. The Type 874-X Insertion Unit is a convenient shielded housing for the resistor and has coaxial terminals for connection to the bridge directly, and/or through Type 874 patch cords.

For standards of very small conductance, a T-network of resistors, as shown in Figure 5-1, must be used. The direct conductance G between the H and L terminals is

$$G = R_T / (AB + R_TA + R_TB)$$

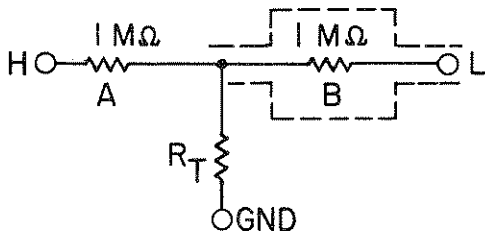

Figure 5-1. T-network for conductance standard.

When $A = B = 1$ megohm, the value of the resistance, R_T , and the corresponding conductance, G , is given in the right-hand columns of Table 5-2. Mount at least the resistor B, connected to the L or detector bridge terminal, in a shield to reduce capacitance and noise pickup. The Type 874-X Insertion Unit can be used to mount this resistor. Note that the error of the T-network conductance may be the sum of any errors in the resistances of R_T , A, and B.

a. Select conductance standard on the basis of the above.

b. Measure the resistance of all resistors used as the external conductance standard (with an ac or dc resistance bridge) and compute the conductance.

c. When the conductance is within the conductance range of the bridge, connect the conductance standard to the bridge UNKNOWN terminals and measure both conductance and capacitance. Follow procedures of para. 3.7.2. Refer to Table 4-1 for resistance and conductance ranges of bridge.

5.2.4.3 Negative External Conductance. When negative G MAX positions must be used to balance loss on the standard side of the bridge in excess of that on the unknown side, and the bridge conductance range or resolution is not adequate, add the external conductance standard in parallel with the unknown:

a. Connect external standard H terminal to UNKNOWN coaxial H terminal, or to H binding post, and connect the L terminal to bridge EXT STANDARD coaxial L terminal (same as connection to UNKNOWN coaxial L terminal).

b. Adjust external conductance for bridge balance by the use of a decade resistor as the external standard or by the use of a decade resistor as R_T in a T-network.

NOTE

The MULTIPLY EXT STANDARD BY switch cannot be used for decade adjustment of negative conductance.

5.2.5 COMPARISON OF EXTERNAL STANDARDS. The accurate calibration of one capacitor can be transferred to another with very small loss in accuracy by using the bridge to measure the capacitance difference between the two capacitors. This difference can be determined by measuring first the capacitance of one capacitor and then that of the other and subtracting, i.e., by a direct substitution of the uncalibrated capacitor for the calibrated one at the bridge UNKNOWN terminals. The difference can also be measured by connecting the calibrated capacitor to the bridge transformer as an external standard, and the uncalibrated as an unknown, and using the bridge decades to balance the capacitance difference, i.e., by a comparison using the transformer ratio arms. These methods can be used to increase calibration accuracy when the accuracy of the calibrated standard exceeds the 0.01% direct-reading accuracy of the bridge.

The possible error in the measurement of the unknown by the comparison technique is the sum of:

1. The error in the calibrated value of the external standard capacitor.
2. The error, $\pm(0.01\% + 0.00001 \text{ pf})$, in the reading of the bridge decades multiplied by the ratio of the decade reading to the unknown capacitance.
3. The error in the bridge transformer ratios, which is typically within ± 1 ppm for a ratio of 1, ± 10 ppm for ratios 2 through 10, ± 20 ppm for the ratios between 10 and 1000.

5.2.5.1 Direct or Equal Substitution. To calibrate a capacitor, A, by comparison with a similar calibrated capacitor, B, of nearly equal magnitude:

a. Connect capacitor A to the appropriate UNKNOWN terminals and measure its capacitance by the applicable procedure in para. 3.7.

b. Connect capacitor B to the same terminals and measure its capacitance. Do not change the setting used in step a for the first two or three bridge decades, if the balance can be made by the use of the (-1) or (X) positions of lower capacitance decades. Any errors in the bridge capacitors will cancel in the difference if the same decade has been used in both measurements.

Example: If the measurement of capacitor A was X00.003 pf and that of capacitor B was X00.(-1)85, the 1000-pf internal capacitor is used for the first decade but the 100-pf and 10-pf are not in use. The same balance could have been made with the bridge reading 999.985, and with all three internal capacitors a part of the balance. Since the measurement of capacitor A was made with the 1000-pf capacitor, any errors in this capacitor will cancel in the difference between A and B. When the 100- and 10-pf bridge capacitors are used for B, but not for A, their errors appear in the difference.

c. To obtain the capacitance of A, subtract the measured capacitance of B from that of A and add the difference to the calibrated value of B.

Example: The calibrated value of B is 1000.005 pf, the difference of the measurements above is X00.003 - X00.(-1)85 = .018 pf. The capacitance of A is 1000.023 pf.

NOTE

The capacitance of the bridge terminals does not have to be subtracted from the two readings of the bridge. When the same bridge terminals are used for both measurements, any terminal capacitance cancels in the difference. However, the calibrated value transferred from B to A is the capacitance added to the particular terminals used when the original calibration of B was made.

5.2.5.2 Comparison Using Transformer Ratio Arms. To calibrate a capacitor, A, by comparison with a calibrated capacitor, B, when the ratio of A/B is close to any integer from 1 to 10, multiplied by 1, 10, or 100:

a. Connect the capacitor, A, to the appropriate UNKNOWN terminals.

b. Connect capacitor, B, to the EXT STANDARD terminals. If B is much larger than A, connect B to the UNKNOWN terminals and A to the EXT STANDARD terminals.

c. Set C MAX and MULTIPLY EXT STANDARD BY. . . to the positions which make the product of M and the reading in the window as close as possible to the ratio A/B.

Example: The nominal capacitances are A = 5000 pf and B = 1000 pf, and A/B = 5. Set C MAX to 0.01 μ f, where M = 10, and set MULTIPLY EXT STANDARD BY. . . to read 0.5.

d. Balance the bridge with the CAPACITANCE and CONDUCTANCE controls.

e. Observe the capacitance of the unknown, A. It should equal the calibrated value of the standard, B, multiplied by M and the reading of the MULTIPLY EXT STANDARD BY. . . switch plus the reading of the bridge CAPACITANCE decades.

Example: Calibrated value of B is 1000.005 pf. C MAX set at 0.01 μ f (M = 10). MULTIPLY EXT STANDARD BY. . . reads 0.5. Bridge decades read 0003.14 pf. Capacitance of A is 1000.005 x 0.5 x 10 + 0003.14 = 5003.16 pf.

5.2.6 BALANCE OF TERMINAL AND LEAD CAPACITANCE. The bridge can be made to read directly the capacitance added to terminals, or leads, by the use of external standard capacitors added to the bridge to balance the capacitance of the terminals and leads. This eliminates the need to subtract from the bridge reading the terminal, or lead, capacitance to obtain the added capacitance.

5.2.6.1 General Procedure.

a. Leave bridge terminals open; or with lead wires or cables connected to bridge terminals leave lead or jig terminals open; or with variable capacitor connected to bridge terminals set capacitor to chosen initial or zero point; or with decade capacitor connected to bridge terminals set capacitor to chosen initial or zero point.

b. Set all bridge CAPACITANCE decades to zero.

c. Balance bridge for capacitance with external variable capacitance connected to bridge EXT STANDARD terminals. Use MULTIPLY EXT STANDARD BY. . . switch to obtain multiplying ratios from 0.1 to 1, when needed.

d. Balance loss with external conductance or with bridge CONDUCTANCE decades.

e. Connect capacitor to be measured to terminals or leads, or change setting of variable capacitor to be measured.

f. Balance bridge with bridge CAPACITANCE and CONDUCTANCE controls. Do not change capacitance connected to EXT STANDARD terminals.

g. Read directly the capacitance added to terminals or leads from bridge CAPACITANCE indications.

5.2.6.2 External Standard Capacitors. Refer to para. 3.7 for connection procedures corresponding to the three measurement positions of the terminal selector. Use any combination of fixed and variable capacitors that will balance the bridge. Capacitors do not need to be calibrated. The external standard capacitance can



TYPE 1615-A CAPACITANCE BRIDGE

be larger than the capacitance it balances on the unknown side, because it can be multiplied in steps from 0.1 to 1 by the MULTIPLY EXT STANDARD BY. . . switch.

1. Three-terminal measurements.

(Terminal selector set to 3 TERM or 3 TERMINAL)

Convenient capacitors are the calibrated, variable, three-terminal Type 1422 precision capacitors.

Capacitance in pf

Type	Max	Min
1422-CB	1100	50
1422-CC	110	5
1422-CD	{ 11 1.1	{ 0.5 0.05

To use two-terminal external capacitors, such as Type 1422-D, for a three-terminal measurement:

a. Connect bridge EXT STANDARD L terminal with shielded cable to capacitor H or insulated terminal. (Type 874-Q9 Adaptor with Type 874-R20A Patch Cord is convenient.)

NOTE

Do not connect cable or adaptor shield (which is connected to the bridge ground) to either capacitor terminal.

b. Connect bridge EXT STANDARD H terminal to capacitor ground terminal (or case). Insulate case from bridge and other grounds, since bridge transformer voltage is connected to capacitor case.

c. Use MULTIPLY EXT STANDARD BY. . . switch, when required, to reduce the effective external capacitance to as little as one tenth that of the capacitor. Cable capacitance is excluded from the external standard capacitance.

2. Two-terminal measurements.

(Terminal selector set to 2 TERMINAL)

Convenient capacitors are the calibrated, variable, two-terminal Type 1422 Precision Capacitors:

Capacitance in pf

Type	Max	Min
1422-D	{ 1150 115	{ 100 35

Cable or lead capacitance adds to the total external standard capacitance. Typical capacitance of Type 874 Patch Cords is 90 to 100 pf. Use similar cables to the unknown and to the external standard to balance most cable capacitances.

Avoid the use of flexible cable and unshielded leads when capacitance changes of less than 1 pf are important; the capacitance of cable and leads may change with position. Use rigid connections or three-

terminal measurements for accuracy in small capacitance.

To balance terminal capacitance less than 10 pf:

a. Use for partial balance the terminal and wiring capacitance of the bridge EXT STANDARD terminal (about 6 pf), multiplied by the ratios of the MULTIPLY EXT STANDARD BY. . . switch.

Example: The terminal capacitance at the open-binding-post UNKNOWN terminals of the bridge (about 1.3 pf) can be partially balanced by the 6-pf EXT STANDARD terminal capacitance multiplied by the 0.2 position of the switch.

b. Add capacitance to the terminals, or leads, on the unknown side of the bridge, when the minimum of external-standard capacitance cannot be reduced enough for balance. To add bridge standard capacitance to the unknown side, set first CAPACITANCE decade to (-1) position and other decades to 0. Balance augmented lead capacitance with external standard capacitors. Then, with first decade left in (-1) position, balance with remaining five CAPACITANCE decades the capacitance added to the leads.

NOTE

Do not use low-capacitance, three-terminal capacitors, such as Types 1422-CC or -CD, as two-terminal external standards. The two-terminal capacitance is the calibrated, small, direct capacitance plus the capacitance from the high terminal to case, which is much larger and has less range of variation.

5.3 CALIBRATION OF TWO-TERMINAL CAPACITORS AT ENDS OF CABLES.

5.3.1 TWO-TERMINAL-BRIDGE METHOD. To measure two-terminal capacitors, such as the Type 1419 Decade Capacitors and the Type 1422 Precision Capacitors, which cannot be plugged directly into the bridge terminals:

a. Set the bridge terminal selector to 2 TERMINAL.

b. Connect the bridge binding posts to the capacitor posts with appropriate coaxial patch cords and adaptors. (Use Type 874-Q9 Adaptor to connect to Type 1422 Capacitors.)

c. Measure the total capacitance of capacitor plus cables and adaptors.

d. Remove the capacitor from the connector at the end of the cable.

e. Measure the capacitance of the cable and adaptors with the cable terminals open.

f. Subtract this cable or lead capacitance from the total to obtain the capacitance added by the capacitor.

g. Alternatively, balance the capacitance of the cable with an external-standard capacitor to make the bridge read zero when the cable terminals are open. The bridge then reads directly the capacitance added by any capacitor connected to the cable terminals. Refer to para. 5.2.6 for use of external standards to balance lead capacitance.

NOTE

Cable or lead capacitance must not change between or during measurements, for accurate measurement of added capacitance. The capacitance of typical coaxial cable may vary by the order of 0.01 to 0.1 pf when the cable is moved. When capacitance errors of this order are important, as in the calibration of Type 1422 Precision Capacitors, use rigid connections, or use the three-terminal-bridge method described below.

5.3.2 THREE-TERMINAL-BRIDGE METHOD. To measure two-terminal capacitors, such as Types 1419 and 1422, at the end of cables (with the cable capacitance and its variations excluded by a three-terminal connection):

- a. Set the bridge terminal selector to 3 TERM.
- b. Connect to the capacitor terminals the connector normally used, or specified, for two-terminal calibration (such as the Type 874-Q9 Adaptor for the Type 1422 Precision Capacitors). Connect the ground (or shield) terminal of the adaptor to the ground (or low terminal, or case) of the capacitor, and the insulated terminal of the adaptor to the insulated (or high) terminal of the capacitor.

c. Connect a coaxial cable to the bridge coaxial L UNKNOWN terminal in the usual manner, with cable shield connected to the outer conductor of the bridge connector.

d. Connect only the inner lead of this coaxial cable to the center (insulated) terminal of the adaptor which has been attached to the capacitor.

e. Leave a small, insulated gap between the shield of the coaxial cable and the connector shield. The gap should be made small (1/16-inch or less) to avoid a leak in the shielding around the inner conductor. The insulation resistance across the gap need be only high enough to avoid loading the bridge transformer (1 megohm or more). The shields and center conductor in the vicinity of the gap must be fixed in position so that the internal capacitances remain constant.

NOTE

To make this connection with an insulated gap in the shield, the components shown in Figure 5-2 can be used. Plug the binding post of a Type 874-MB Coupling Probe into the banana plug of a Type 874-Q9 Adaptor. Unscrew the head of the binding post to adjust its length until probe and adaptor fit tightly together with a gap of about 1/16-inch between their shields. For additional mechanical rigidity, wrap the gap with electrical tape. Connect one end of this assembly to the other Type 874-Q9 Adaptor, which is connected to the capacitor, and the other end to the coaxial cable.

f. Connect the bridge UNKNOWN H coaxial terminal or UNKNOWN H binding post to the shield of the

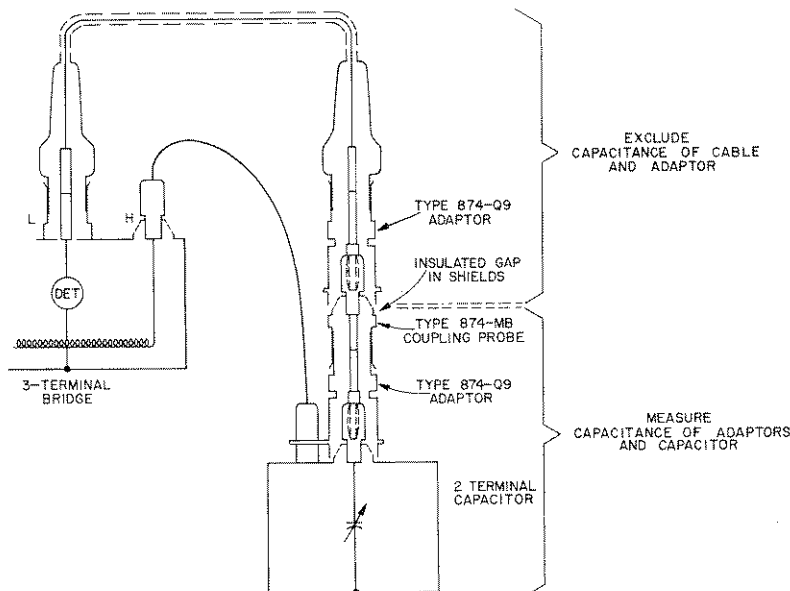

Figure 5-2. Connection for 3-terminal measurements on 2-terminal capacitors.



TYPE 1615-A CAPACITANCE BRIDGE

connector (Type 874-Q9) that is attached to the capacitor ground terminal. Insulate the capacitor case from any connection to the bridge ground or external grounds.

NOTE

The capacitances measured by the bridge are then, the capacitance within the capacitor from the high terminal to case and the capacitance within the connector from the center conductors to the outer shields as far up as the gap. The capacitances excluded are those from the cable center conductor to shields on the bridge side of the gap.

g. Measure the total capacitance of the capacitor plus the connectors.

h. Remove the capacitor from the connector and, with the lead from the H terminal of the bridge still connected to the connector shield, measure the capacitance of the open connector.

i. Subtract this connector capacitance from the total capacitance to obtain the capacitance added by the capacitor.

j. Alternatively, balance the connector capacitance with a three-terminal external-standard capacitor to make the bridge read zero when the connector is open. The bridge then reads directly any capacitance added to the connector. Refer to para. 5.2.6 for use of external standards in this application.

k. Use this three-terminal connection to exclude cable capacitance, and capacitance changes from any other measurement of two-terminal capacitance, where bridge ground can be isolated from capacitor ground.

5.4 APPLICATION OF DC BIAS TO UNKNOWN.

Dc biasing voltages may be applied in either of two ways to a capacitor that is being measured on the bridge.

CAUTION

Do not apply voltage at the bridge DETECTOR terminals in excess of the voltage, E_{MAX} , in Table 5-3.

5.4.1 NORMAL OPERATION. To apply bias in parallel with the detector, use the following procedures:

a. Connect the bridge for normal operation, but add the dc bias supply in parallel with the detector, as shown in the circuit of Figure 5-3.

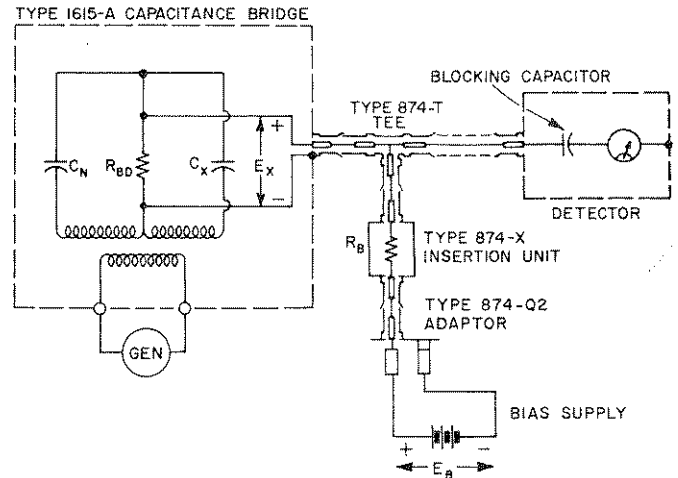

Figure 5-3. Circuit for applying bias to an unknown.

b. Shield all leads connected to the high side of the detector. Use a Type 874-T Tee connector for convenient parallel connection of bias.

c. Connect a series capacitor between detector input and bias supply to block bias voltage from the input stage. (This capacitor is usually built into the detector input stage.)

d. Connect a series resistor, R_B , between the high detector lead and the bias supply to prevent the low impedance of the bias supply from shorting the detector input. A resistance of about 100 kilohms will usually suffice. Lower resistance reduces the detector sensitivity; higher resistance reduces the dc voltage across the unknown since

$$E_X = \frac{E_B R_{BD}}{R_B + R_{BD}}$$

Refer to Table 5-3 for the bridge resistance, R_{BD} , at the DETECTOR terminals.

e. Install a shield such as a Type 874-X Insertion Unit around the resistor.

NOTE

Use a choke in place of R_B for high impedance, when low dc voltage drop is needed but shield the choke from both magnetic and electrostatic pickup.

f. Connect the bias power supply, or battery, between R_B and the outer conductor of the DETECTOR terminal of the bridge, which is also connected to the bridge case and ground. Either polarity of dc bias can be applied to the bridge. Connect the supply to apply the polarity required by the capacitor being tested.

TABLE 5-3
MAXIMUM VOLTAGE AT BRIDGE DETECTOR TERMINALS

TERMINAL SELECTOR POSITION	G MAX-D MAX CONTROL SETTING	R _{BD} OHMS	E _{MAX} * VOLTS
CAL, 3 TERM, 3 TERMINAL	D	>10 M	500
	G	100 k	150
2 TERMINAL	D	1 M	500
	G	90 k	150

* Dc or rms ac.

5.4.2 REVERSE OPERATION. To apply bias in series with the generator, use the following procedure:

a. Connect the bridge for operation with reversed generator and detector. Refer to para. 5.5.

b. Connect the dc bias supply, or battery, in series with the ac generator. Use, for example, the Type 1265-A Adjustable DC Power Supply, which is designed for series connection to the Type 1265-A Adjustable AC Power Source, or to the Type 1308-A Audio Oscillator and Power Amplifier.

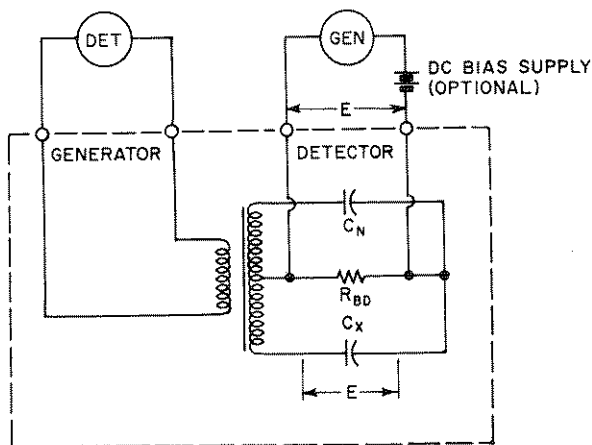

Figure 5-4. Bridge circuit with generator and detector reversed.

5.4.3 DIRECT CURRENT IN TRANSFORMER.

When the capacitor (C_X, that is measured with bias by either of the preceding methods) has leakage resistance, a direct current will flow through one of the bridge ratio transformers. This current will magnetize the core and affect the accuracy of the ratios, and such use generally is not recommended. It is, however, possible to operate the bridge with some dc in the transformers, if the total current (dc plus peak ac) is kept below the values shown in Table 5-4 to avoid saturation of the cores. Operation within these limits will not damage the bridge, but the transformers should be demagnetized after such use to insure accuracy in normal operation.

To demagnetize, set the generator (1311) to 100 Hz and connect it to the bridge UNKNOWN H and L (or G) binding posts. Set the bridge terminal selector to the CAL position. To demagnetize T101, set C MAX to 1000 pF, increase the generator output from 0 to about 10 V, and then slowly decrease back to 0. To demagnetize T102, set C MAX to 0.1 μF and repeat the procedure.

TABLE 5-4
CURRENT LIMITS FOR TRANSFORMER-CORE SATURATION

C MAX	I _{max}	TRANSFORMER
1 μF	0.8 A	T102
0.1 μF	0.08 A	T102
0.01 μF	0.08 A	T101
1000, 100, 10 pF	0.008 A	T101

5.5 GENERATOR AND DETECTOR REVERSED.

5.5.1 GENERAL. The bridge may be operated with the generator connected to the bridge DETECTOR terminals and the detector connected to the bridge GENERATOR terminals (see Figure 5-4). Use reversed connection when higher-voltage operation is required and when lower sensitivity can be tolerated.

To apply higher voltage to the unknown capacitor than that permitted by the normal generator connection reverse operation must be used. In normal operation, the maximum voltage across the unknown capacitor is limited by transformer-core saturation and by transformer ratio to

$$E_{MAX} = \frac{30 \times (\text{freq in kc})}{M}$$

The factor M has the values of 10, 100, or 1000 as the C MAX control is changed from 1000 pf to 1 μf.

In reversed operation, the maximum voltage is limited by power dissipation in bridge resistors, or by



insulation breakdown, and depends upon the positions to which the terminal selector and D MAX-G MAX control are set. The maximum voltage, E_{MAX} that can be applied to the DETECTOR terminals and to the unknown capacitors is given in Table 5-3.

With reversed operation the sensitivity of the bridge balance is usually lower than that obtained with normal operation, but normal resolution may be retained as a result of the higher generator voltage that can be applied. When the detector is connected to the bridge GENERATOR terminals (hence, to the bridge transformers) the balance sensitivity is generally reduced by the mismatch between the low transformer reactance and the much higher capacitor reactance, particularly for frequencies below 1 kc and for capacitances below 1000 pf. For example, the capacitance unbalance that can be easily seen on the 1232-A Null Detector is of

the order of ± 0.01 pF when the bridge is driven with 100 V at 50 Hz and ± 0.0001 pF for 100 V at 1000 Hz.

5.5.2 REVERSE OPERATION. To operate the bridge with reversed generator and detector:

a. Connect the generator to the bridge DETECTOR coaxial terminal. Use Type 874-Q2, or Type 874-Q9 Adaptors, or Type 874-R34 Patch Cord, for easy connection of coaxial terminal to binding posts.

b. Connect detector to bridge GENERATOR binding posts; shielding must be complete. Use Type 874-Q9 Adaptor to connect coaxial lead to binding posts. Type 874-R34 Patch Cord may be used, but the cable should be checked for leaks through the single-braid shield of this coaxial cable. Refer to para. 6.7.3.

c. Use normal procedures in Section 3 for bridge operation.

SECTION 6

CALIBRATION AND ADJUSTMENT

6.1 GENERAL.

Procedures in this section provide rapid means of test for normal performance of bridge components (and of generator and detector) without the use of special test equipment. These self-check procedures include the test and adjustment of the ratio of the internal decade standard capacitors for consistent bridge readings of capacitance on all decades and ranges. Procedures are given for testing bridge accuracy with respect to external standards of capacitance, dissipation factor, and conductance and for the adjustment of the bridge capacitance calibration.

NOTE

All tests and adjustments described in this section can be made without disassembly of the bridge. Tests, adjustments, and repairs which require the removal of bridge case and shields are described in Section 7, Service and Maintenance.

6.2 SELF-CHECK PROCEDURES.

6.2.1 GENERAL. The following procedures utilize a built-in calibration mode of operation (see Figure 6-1), and in no way alter the specified accuracy of the instrument. They may be performed at any time and in a selective fashion, depending upon whether a routine proof-of-performance is required or whether fine calibration is needed. If any of the procedures fail to give the indicated result, refer to Section 7, Service and Maintenance.

Used to Measure:

1. Zero error of bridge.
2. Sensitivity and operating condition of bridge, generator, and detector.
3. Performance of decade switches, transformer, and resistors.
4. Ratio of bridge standard capacitors.

Terminals: The terminals for unknown and external standards are not used. The UNKNOWN H and L and EXT STANDARD L coaxial terminals are internally

connected to ground. The transformer voltages remain connected to the H binding post through the C MAX switch and to the EXT STANDARD H coaxial terminal through the MULTIPLY EXT STANDARD BY. . . switch.

For rough checks of operation, capacitors can be left connected to UNKNOWN or EXT STANDARD terminals without major effect.

For accurate calibrations, remove any capacitor connection to EXT STANDARD H binding post and set MULTIPLY EXT STANDARD BY. . . switch to zero to prevent loading of transformer by external capacitors.

6.2.2 ZERO CHECK. Procedures are as follows:

- a. Set generator and detector for 1-kc operation.
- b. Adjust generator output for approximately 30 volts into bridge. Bridge voltage can be measured conveniently between UNKNOWN H and L (or GND) binding posts.
- c. Set terminal selector to CAL.
- d. Set C MAX to 10 pf.
- e. Set D MAX to 0.01, and DISSIPATION FACTOR controls to 0000.

NOTE

To increase sensitivity for better resolution of last C decade, increase generator frequency to 5 kc and output to 100 volts.

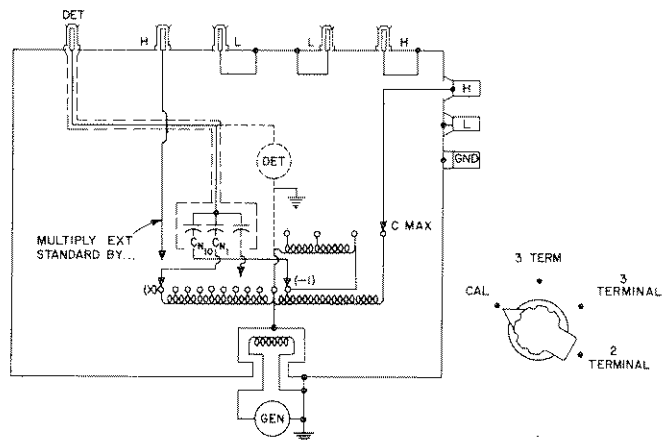

Figure 6-1. Type 1615-A bridge circuit for calibration setting.



f. Balance bridge with CAPACITANCE controls. Null should occur with CAPACITANCE controls set at $0.00\ 000 \pm 0.00\ 003$. Change of DISSIPATION FACTOR controls will not affect balance, but capacitance balance is more sensitive when D is used instead of G. If loss balance is required, change from D MAX to a G MAX position and balance with CONDUCTANCE decades.

g. Correct any bridge reading, when zero error is present (i.e., not 0.00 000), by subtracting from that reading of capacitance, the reading of the bridge for the zero check multiplied by the factor M corresponding to the C MAX range used for the reading being corrected.*

Example: Zero reading is 0.00 0(-1)7 or -0.00 003 pf. If bridge reads 9.75 314 with C MAX at 10 pf ($M = 1$), the correct unknown capacitance is $9.75\ 314 - (-0.00\ 003) = 9.75\ 317$ pf.

6.2.3 SENSITIVITY CHECK. Procedures are as follows:

a. Set bridge as above for zero check with input of 30 volts at 1 kc.

b. Balance bridge as for zero check. Results should be very close to zero on D and C dials.

c. Move any CAPACITANCE control from the 0 position. Detector deflection should increase in proportion to the change in the capacitance reading of the bridge.

d. Judge detector sensitivity by the deflection shown when a given change is made in the setting of the CAPACITANCE controls.

Example: When the fourth lever is moved from zero to 1, so that the dials read 0.00 100, the resulting detector deflection is approximately that for any unbalance of 0.001 pf on this range.

The magnitude of the voltage into a detector with input impedance of 50 kilohms or greater, such as the Type 1232-A, is (with 30 volts into the bridge) approximately 1 mv for a capacitance unbalance of 0.07 pf, and 1 μ v for an unbalance of .00 007 pf. Sensitivity of the Type 1232-A should provide easily visible deflection for a capacitance change as small as 0.00 003 pf with 30-volt input at 1 kc.

6.2.4 SWITCH, TRANSFORMER, AND DECADE RESISTOR CHECKS. The relation between bridge unbalance and detector deflection can be used as a rough check for proper operation of the CAPACITANCE controls, which connect to the transformer taps, and of the DISSIPATION FACTOR-CONDUCTANCE controls, which connect decade resistors.

6.2.4.1 Capacitance Control Check. Check CAPACITANCE controls as follows:

a. Set one lever to X position; set the other five to 0.

b. Set detector for LINEAR meter indication.

c. Set detector GAIN for full-scale deflection (100 on Type 1232-A scale).

d. Move lever from X through 0 step-by-step. Meter deflection should decrease by 0.1 full-scale for each lever step, with an accuracy limited by the linearity of the meter movement; e.g., when lever is at 5, meter should read half scale, or 50.

e. Check that deflection produced by X position of any lever is the same as that produced by the 1 position of the next lever to the left.

f. Check that the deflection produced by the change from 0 to the -1 position is the same as that of the change from 0 to the +1 position on any switch.

NOTE

Correction must be made for any small error in the zero reading when deflection checks are made with the levers of the two smallest capacitances.

6.2.4.2 Loss Control Check. Check CONDUCTANCE controls as follows:

a. Set all CAPACITANCE controls to zero.

b. Set G MAX to $+0.01\ \mu S$.

c. Set one CONDUCTANCE lever to X position; set the other three to 0.

d. Check deflection changes for each step of lever by same method as in step d of para. 6.2.4.1.

6.2.5 CAPACITOR RATIO CHECK. The ten-to-one ratio of the eight standard capacitors in the bridge can be checked quickly against the stable and accurate ratio of the bridge transformer by the following method:

a. Set D MAX to 0.01 and terminal selector to CAL.

b. Set four DISSIPATION FACTOR controls to 0.

c. Set C MAX to 1000 pf.

d. Set left-most CAPACITANCE lever to -1. This connects the 1000-pf internal capacitor to the 0.1 tap on the unknown side of the transformer. (see Fig. 6-1).

e. Set the second CAPACITANCE lever to X. This connects the 100-pf internal capacitor to the full transformer voltage on the standard side.

f. Balance the bridge with the remaining four levers. If the capacitors have an exact 10:1 ratio, these levers should indicate balance at (-1) X0.000 pf. Any error in the ratio can be read to 0.001 pf or 10 ppm, and detector meter deflection can be interpolated to 1 ppm.

When the ratio errors exceed the tolerance required, say $\pm(30\ \text{ppm} + 0.00\ 003\ \text{pf})$, the ratio can be re-adjusted with the trimmers on the standard capacitors, which are accessible beneath the sliding cover on the bridge panel. Follow the calibration-adjustment procedures in para. 6.3.

Compare the other six pairs of capacitors in similar fashion, using the appropriate C MAX and lever positions indicated in Table 6-1. Balance of loss should not be required in comparing these low-loss standards.

* Refer to para. 6.7 for elimination of source of error in bridge zero.

TABLE 6-1
SETTINGS FOR INTERNAL-STANDARD
CAPACITOR RATIO CHECKS

TO CONNECT AS		Set C MAX to	CAPACITANCE should read					
UNKNOWN	STANDARD							
1000 pf	100 pf	1000 pf (or .01, 0.1, 1 μ f)	(-1)	X	0.	0	0	0
100 pf	10 pf	100 pf	(-1)	X.	0	0	0	0
10 pf	1 pf	10* pf	(-1).	X	0	0	0	0
1 pf	0.1 pf	10* pf	0.	-1	X	0	0	0
0.1 pf	0.01 pf	10* pf	0.	0	-1	X	0	0
0.01 pf	0.001 pf	10* pf	0.	0	0	-1	X	0
0.001 pf	0.0001 pf	10* pf	0.	0	0	0	-1	X

*Refer to paragraph 6.2.6.

If a small amount of loss difference prevents adequate precision of the capacitance balance, use the $\pm 0.01 \mu$ positions of the G MAX lever. The D MAX positions will have no effect on the relative loss of internal capacitors.

NOTE

To increase precision (when comparison of capacitors below 1 pf is made), set the frequency to 5 kc and the input voltage to 100 volts.

6.2.6 USE OF COMPARISON TABLE (Refer to Table 6-1). When the bridge shows an error of 0.00 001 pf or more in the zero check above, change the comparison procedure as follows:

a. Set the last two CAPACITANCE controls to the reading they have when the bridge is balanced for the zero check.

Example: Zero check reads 0.00 0(-1)7 pf. To compare the 10- and 1-pf capacitors, set the CAPACITANCE controls to (-1).X0 0(-1)7 pf.

b. When Table 6-1 calls for an X position of a decade where the corresponding zero-check reading is (-1), set that decade control to 9.

Example: Table calls for 0.00(-1)X0; zero reading is 0.00 0(-1)7. Set decades to 0.00(-1)97.

c. When the table calls for an X in a decade where the zero reading is neither 0 nor (-1), use the detector meter deflection for comparison as follows:

- (1) Set the detector for LINEAR meter deflection.
- (2) Set the CAPACITANCE decades to 0.00 010 pf.
- (3) Adjust detector gain for nearly full-scale deflection and observe meter reading.

(4) Set the CAPACITANCE decades to 0.00 00X.

(5) Meter deflection should be the same as in item 3 above.

Estimate amount of any error by comparing with change in deflection when last decade is moved one step from X to 9.

When the error is greater than $\pm(0.01\% + 0.00003 \text{ pf})$ or than the required accuracy (if higher) refer to para. 6.3.

6.3 CAPACITOR CALIBRATION-ADJUSTMENT.

Procedures which follow utilize external standards and entail possible minor adjustments in internal capacitance standards. They should not be undertaken unless the recommended standards are available and a need for adjustment has been established as a result of the self-check procedures (refer to para. 6.2). If indicated balance results cannot be accomplished by use of these procedures, refer to Section 7, Service and Maintenance.

The recommended capacitor for bridge calibration to $\pm 0.01\%$ or better is a 1000-pf Type 1404-A or a 100-pf Type 1404-B Reference Standard Capacitor that has been calibrated by the National Bureau of Standards or other standards laboratory to an accuracy of ± 50 ppm or better.

The reference capacitor should have a stable mechanical structure to prevent changes with time and motion, should be hermetically sealed to prevent changes with atmospheric pressure and humidity, should have three-terminal connections to reduce connection errors, and should have a temperature coefficient below 10 ppm/ $^{\circ}$ C to avoid unusual temperature-control requirements.



TYPE 1615-A CAPACITANCE BRIDGE

High-quality mica capacitors, such as the Type 1409 series, are not recommended for this bridge calibration because their temperature coefficient of about $+35 \text{ ppm}/^\circ\text{C}$ makes necessary a careful control of temperature. The usual unshielded-plug connectors, even with three-terminal measurement techniques, can also introduce significant uncertainties in the measurement of a 1000-pf, or smaller, capacitor. When such mica capacitors must be used, the capacitance should be 0.01 or $0.1 \mu\text{f}$.

6.3.1 BRIDGE STANDARD VS REFERENCE STANDARD. The bridge standard capacitors are provided with adjustable trimmers which can be used to set the bridge capacitance to precise agreement with a calibrated reference capacitor. The general procedure is to adjust one bridge capacitor, usually the 1000-pf or 100-pf, to agree with the nearly equal reference capacitor. The other bridge capacitors are then adjusted, in decade steps with reference to this capacitor, by use of the accurate 10:1 transformer ratio in the bridge.

To adjust the 1000-pf bridge capacitor to agree with a 1000-pf reference capacitor (Type 1404-A), proceed as follows:

- Set terminal selector to 3 TERM.
- Connect reference standard to UNKNOWN coaxial terminals, H to H and L to L.
- Set C MAX to 1000 pf.
- Set CAPACITANCE controls to the calibrated value of the reference capacitor.
- Use X on the first CAPACITANCE dial to connect the entire internal 1000-pf capacitor to the standard side of the bridge.
- Use as many zeros as possible on the next dials to remove effects of any errors in the calibration of the bridge capacitors of 100 pf, 10 pf, etc. Use (-1) on dials when reference capacitance is less than 1000 pf.

Example: Calibrated value of Type 1404-A is 999.983 pf. Set CAPACITANCE controls to X00. (-1)83 pf.

6.3.2 ADJUSTMENT OF INTERNAL STANDARD. (See Figure 6-2.)

- Loosen the two screws holding the small panel above the DISSIPATION FACTOR dials and slide panel up to uncover holes containing adjusting screws of trimmers.

NOTE

Use a screwdriver that has an insulated shaft to prevent noise pickup in the detector, which is connected to the trimmer screws.

- Adjust trimmer of 1000-pf capacitor (through hole marked 1000), for capacitance balance, if required. Do not change setting of CAPACITANCE controls (para. 6.3.1).

- Use CONDUCTANCE controls and appropriate + or -G MAX switch position for loss balance, if required. When loss of internal capacitors is greater than that of reference standard, negative G MAX will be needed and balance could not be obtained on any D MAX position.

- Remove reference standard capacitor connection from bridge when balance has been obtained.

6.3.3 OTHER INTERNAL STANDARDS. To adjust the 100-pf bridge capacitor to a 100-pf reference capacitor (Type 1404-B), follow the same procedure as above, except set C MAX lever to 100 pf and adjust trimmer of 100-pf capacitor through hole marked 100 (see Figure 6-2).

6.3.4 ADJUSTMENT OF OTHER BRIDGE CAPACITORS. The remaining seven bridge capacitors may now be adjusted to the calibrated bridge capacitor, and to a

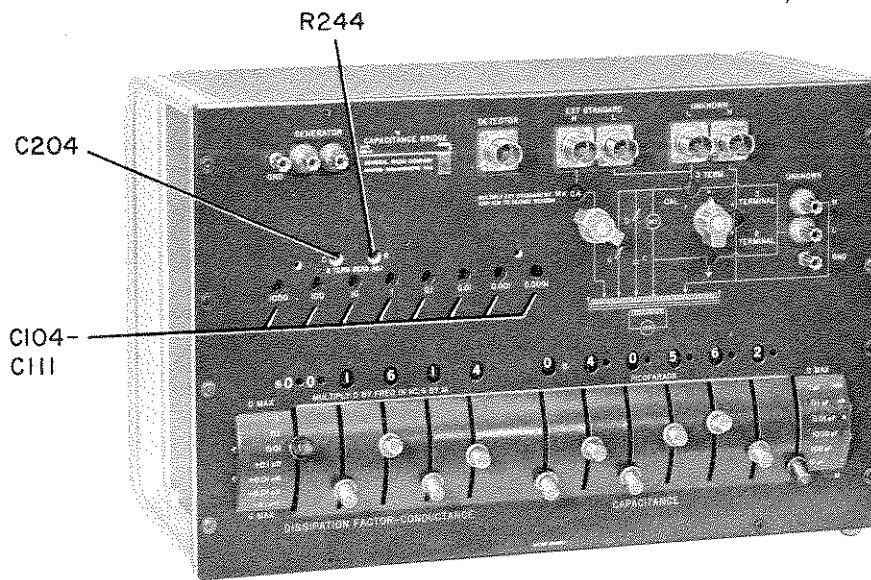

Figure 6-2. Trimmer controls for calibration adjustment of Type 1615-A (shown with access panel removed).

precise 10:1, ratio by connecting them in pairs to the 0.1 tap on the unknown side of the transformer and to the full voltage on the standard side. Balance should be made to a precision of at least one step in the 0.001 pf lever, i.e., to 10 ppm in 100 pf. Precision to 1 ppm can be obtained by balancing to obtain equal detector deflections when the 0.001-pf lever is moved one step above and below its initial setting. The procedure is as follows:

- a. Set terminal selector to CAL.
- b. Set D MAX to 0.01.
- c. Set four DISSIPATION FACTOR controls to 0.
- d. Set C MAX to 1000 pf.
- e. Set six CAPACITANCE controls to read (-1) X0.000. This connects internal 1000 pf to 0.1 tap on unknown side and 100 pf to full voltage on standard side.
- f. Adjust trimmer of 100-pf capacitor through hole marked 1000 (see Figure 6-2).

NOTE

Loss adjustment is seldom required. When needed to obtain precise C balance, move to a G MAX position and balance with CONDUCTANCE controls. Return to previous D MAX position.

6.3.5 ADJUSTMENT OF SMALLER BRIDGE CAPACITORS. Repeat comparison and adjustment procedure (para. 6.3.4) for the 100-pf and 10-pf capacitor pair and for the other pairs with the bridge settings given in Table 6-2.

CAUTION

Before comparing the 10-pf and 1-pf capacitors or the smaller pairs where C MAX is set to 10 pf, check the bridge zero by procedure described in para. 6.2.2.

6.3.6 ALTERNATE PROCEDURES. When the zero balance differs from 0.00 000 pf by 1 or more in the last figure, change the comparison procedure as follows:

- a. Set the last two CAPACITANCE decades to the readings they have when the bridge is balanced for the zero check (para. 6.2.2).
Example: When the bridge is checked for zero capacitance, the balance occurs for a reading of 0.000(-1)7 pf.
To compare the 10-pf and 1-pf capacitors, set the CAPACITANCE levers to (-1).X0 0(-1)7 pf.
- b. When Table 6-2 calls for an X to be set in a decade where the corresponding zero-check reading is (-1), set that decade to 9.

Example: Table 6-2 calls for 0.00 (-1)X0; zero reading is 0.00 0(-1)7. Set levers to 0.00 (-1)97.

6.3.7 ADJUSTMENTS USING DETECTOR-METER DEFLECTION. When Table 6-2 calls for an X in a decade where the zero-reading is neither 0 nor (-1), use detector meter deflection for adjustment as follows:

- a. Set detector for LINEAR meter deflection.
- b. Set CAPACITANCE levers to 0.00 010 pf.
- c. Adjust detector gain for nearly full-scale deflection. Observe meter reading.

NOTE

If increased detector sensitivity and balance precision is needed, set the generator and detector to 5 kc and the input voltage to 100 volts.

- d. Set the CAPACITANCE levers to 0.00 00X.
- e. Adjust the trimmer marker 0.0001 to obtain the same meter deflection obtained in step c above.

This calibration method, when bridge zero error is present, makes any bridge reading correct when the zero error in pf, multiplied by the factor M correspond-

TABLE 6-2
BRIDGE SETTINGS TO COMPARE INTERNAL STANDARDS
(SEE FIGURE 6-2)

TO COMPARE		Set C MAX to	Set CAPACITANCE controls to						ADJUST TRIMMER MARKED
UNKNOWN SIDE pf	STANDARD SIDE pf								
1000	100	1000 pf	-1	X	0.	0	0	0	100
100	10	100	-1	X.	0	0	0	0	10
10	1	10	-1.	X	0	0	0	0	1
1	0.1	10	0.	-1	X	0	0	0	0.1
0.1	0.01	10	0.	0	-1	X	0	0	0.01
0.01	0.001	10	0.	0	0	-1	X	0	0.001
0.001	0.0001	10	0.	0	0	0	-1	X	0.0001



ing to the C MAX setting, is subtracted from the bridge reading of capacitance.

Example: The zero reading is 0.00 0(-1)7 pf. The zero error is -0.00 003 pf. When the bridge reads 9.75 314 with C MAX at 10 pf and M = 1, the correct capacitance is 9.75314 - (-0.00 003) = 9.75 317 pf.

6.3.8 POST-ADJUSTMENT CHECKS. Remeasure the reference capacitor by the procedures of para. 6.3.1, after all bridge-capacitor adjustments have been completed. If the bridge does not balance with a reading equal to the calibrated value of the reference capacitor within the desired bridge accuracy (say, ±50 ppm), the adjustments of para. 6.3.2 and 6.3.4 must be repeated. Such readjustment will be required only if very large errors were present in the smaller capacitors used when the bridge 1000-pf capacitor was first adjusted to the reference standard.

6.3.9 BRIDGE CAPACITOR ADJUSTMENT WITHOUT REFERENCE STANDARD. The comparison and adjustment of the bridge capacitors in para. 6.3.4 can be made at any time, if a reference standard is not available for the bridge capacitor calibration of para. 6.3.1. In such adjustment, one of the bridge capacitors, say the 1000-pf, is assumed to be the best available standard. This capacitor is not adjusted, but the other bridge capacitors are trimmed to agree with the chosen standard so that there are no internal inconsistencies in bridge readings from range to range and from decade to decade. The percent error in the absolute capacitance of the bridge capacitor chosen as reference is, therefore, the percent error of any bridge reading. This error can be determined by a subsequent measurement of a calibrated reference-standard capacitor, and the appropriate correction applied to measurements made with the bridge.

6.4 CONDUCTANCE CALIBRATION.

6.4.1 CONDUCTANCE STANDARDS. A standard of conductance of 1 micromho or more is usually a calibrated resistor. For conductance much smaller than a micromho, a T-network of three calibrated resistors is used as a standard to keep the resistance magnitudes within the range of readily available accurate resistors. The equivalent circuits of both forms of standard are shown in Figure 6-3. The relation of G to R, for the circuit in Figure 6-3 (a), when conductances G are in mhos and resistances R are in ohms is

$$G_{HL} = \frac{1}{R} \quad (6-1)$$

A 1-megohm resistor, therefore, has a conductance of 1 μmho. For small conductances, the circuit is as shown in Figure 6-3(b) and the relation is

$$G_{HL} = \frac{R_C}{R_A R_B + R_A R_C + R_B R_C} = \frac{G_A G_B}{G_A + G_B + G_C} \quad (6-2)$$

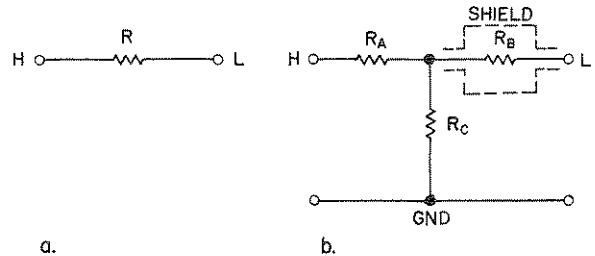

Figure 6-3. Equivalent circuits for conductance standards.

To check the 1% conductance accuracy of the bridge, use a standard conductance with a calibrated or measured accuracy of 0.25% or better.

For conductance of 1, 10, or 100 micromhos, use, for example, a Type 1432 Decade Resistor (±0.05%) set at 1 megohm, 100 kilohms, or 10 kilohms, or a Type 500 Resistor of appropriate value.

For a smaller conductance, such as 0.01 micromho, construct the T-network of Figure 6-3(b) as follows:

a. Use for resistor B a fixed, precision resistor mounted in a shielding enclosure, such as the Type 874-X Insertion Unit. The shielding is required to prevent noise pickup at the terminal L, which is connected to the detector and has the high impedance (to ground) of resistor B.

b. Use for resistors A and C fixed, precision resistors or decade boxes. Shielding is not essential because terminal H is connected to the low-impedance transformer output of the bridge and the impedance of resistance C can be made 1000 ohms or less.

c. Measure the resistance of all resistors that do not have accurate calibration. Use an accurate bridge, such as the 0.1% Type 1608-A Impedance Bridge.

d. Calculate the conductance, G_{HL} , from Equations 6-1 and 6-2.

Example: For a conductance of 0.01 μmho, the nominal values of A, B, and C in a T-network are 100 kilohms, 100 kilohms, and 100 ohms. The values measured on a Type 1608-A Impedance Bridge are $G_A = 10.020 \mu\text{mho}$, $G_B = 10.061 \mu\text{mho}$, and $R_C = 99.52 \text{ ohms}$. The calculated conductance is $G_{HL} = 0.01001 \mu\text{mho}$. If the accuracy of each of the three measured values is ±0.1%, there is a possible error of 0.3% in the calculated G_{HL} .

6.4.2 CONDUCTANCE CALIBRATION PROCEDURES.

6.4.2.1 General. The accuracy of the bridge reading of conductance depends upon the accuracy of the internal 100-kilohm resistors, A and B, and the decades, R_N , used in the bridge conductance T-network (see Figure 4-15). In the factory calibration, the bridge conductance accuracy is limited to $\pm 1\%$ chiefly by the $\pm 0.5\%$ accuracy of the two 100-kilohm resistors. The adjustment accuracies of the resistors, R_N , used for both conductance and dissipation factor are ± 0.05 , ± 0.05 , ± 0.15 , and $\pm 0.5\%$ for the decade steps of 100, 10, 1, and 0.1 ohms, respectively.

The following calibration procedures measure the combined errors from all resistors. To separate errors in R_N from those in the resistors A or B, or in the transformer ratio taps, watch for these distinguishing characteristics:

1. An error in a resistor in the R_N decades will appear in the same decade switch on all G MAX ranges and on all D MAX ranges. Refer to para. 6.5 for dissipation-factor calibration; for calibration of R_N decades alone, refer to para. 6.6.

2. An error in the A or B resistors will produce the same percent error on all G MAX ranges and all readings on a particular range.

3. An error in one of the four transformer ratios, to which the T-network is switched to change the G MAX range, will affect only the corresponding G MAX range.

NOTE

Make the corrections of conductance readings for the error produced by the nonlinear relation between G and R_N before the determination of errors from other sources. Refer to para. 3.8.3.

6.4.2.2 Large Conductances. To check the accuracy of, primarily, the two 100-kilohm bridge resistors on one or both of the +G MAX ranges with a calibrated fixed or decade resistor of 10, 100, or 1000 kilohms, use the following procedure:

a. Set the bridge for a three-terminal measurement at 1 kc with binding-post connections. Refer to para. 3.7.4 for 3 TERMINAL operation.

b. Connect the calibrated resistor to the H and L UNKNOWN binding posts. Shields around the resistor are not usually required but may be used to reduce noise pickup; connect shields or resistor cases to the bridge GND post.

c. Set the bridge C MAX and G MAX range controls to the positions indicated in Table 6-3 appropriate to the resistor used.

TABLE 6-3
CONDUCTANCE STANDARDS
FOR RANGE CALIBRATIONS

RESISTOR	C MAX	G MAX
1 M Ω	0.1 μf	+0.1 or +0.01 μV
100 k Ω	1 μf	+0.1 or +0.01 μV
10 k Ω	1 μf	+0.1 μV

d. Balance the bridge with the conductance and capacitance decades and record the bridge readings at balance.

Example: Calibrated resistor is a Type 1432-P. Decade Resistor set at 100 kilohms (accuracy $\pm 0.05\%$); C MAX set at 1 μf and G MAX at 0.01 μmho . At balance, bridge G decades read .00 X165 and C decades read 000 025. pf.

e. Apply to conductance decade reading the multiplier M and the corrections of para. 3.8.3.

Example: For C MAX at 1 μf , $M = 1000$, to correct for decade zero resistance add 1 to reading of fourth decade and obtain corrected reading X166. To correct for nonlinear relation of G to R_N , subtract from decade reading $2(10.166)^2$ and obtain corrected decade reading $(10166-207) = 9959$. Corrected conductance is, then, $.00 9959 \times (M = 1000) = 9.959 \mu mho$.

f. Compare the corrected bridge reading to the calibrated conductance, which can be calculated from the calibrated value of the resistor (refer to Equation 6-1). Accuracy of the corrected bridge reading should be within $\pm(1\%$ of measured value $+0.00001 \mu mho)$.

Example: The conductance of the 100-kilohm calibrated decade box is $10.000 \mu mho \pm 0.05\%$. The bridge reading of 9.959 is low by $0.040 \mu mho$ or by 0.4%. The product of the 100-kilohm resistances in the bridge is, therefore, nearly 0.4% low.

g. Repeat the measurement of the same or another resistor on the other +G MAX range; refer to Table 6-3 when required to check another transformer tap and different R_N decade resistors. Bridge error should remain the same within $\pm 0.1\%$ when the error source is the 100-kilohm resistors.

6.4.2.3 Small Conductances. To check the accuracy of, primarily, the two 100-kilohm bridge resistors on all four G MAX ranges with a calibrated small conductance, such as 0.01 μmho , use the following procedure:

a. Set the bridge for a measurement at 1 kc and for a three-terminal measurement with coaxial connections. (Refer to para. 3.7.3 for 3 TERM operation.)

b. Connect a calibrated 0.01 μmho conductance standard (such as the T-network described in para.6.4.1.



above), to the bridge coaxial H and L UNKNOWN terminals. All high impedances in the standard should be shielded and connected with coaxial cable to the bridge L terminal. Connect shields to the bridge GND terminal or coaxial terminal outer conductors.

c. Set the bridge C MAX control to the 1000-pf position or to the 100- or 10-pf positions as required for adequate precision in the capacitance balance.

d. Set the bridge G MAX control to the +0.01 μmho position.

e. Balance the bridge with the conductance and capacitance decades and record the bridge readings at balance.

Example: Calibrated conductance is the T-network of the example in para. 6.4.1 with a conductance of 0.01001 μmho and an accuracy of about $\pm 0.1\%$. At balance G decades read .00X184 and C decades read 00.0010.

f. Apply to the conductance decade reading the multiplier M and the corrections of para. 3.8.3.

Example: For C MAX at 1000, 100, or 10 pf, $M = 1$. To correct for decade zero resistance, add 1 to reading of the fourth decade and obtain a corrected reading X185. To correct for nonlinear relation of G to R_N , subtract from decade reading $2(10.185)^2$ and obtain corrected reading $(10185 - 207) = 9978$. Corrected conductance is, then, $.009978 \times (M=1) = .009978 \mu\text{mho}$.

g. Compare corrected bridge reading to the calibrated value of the standard. Accuracy of the bridge reading should be within $\pm(1\%$ of measured value + 0.00001 μmho).

Example: Conductance of the T-network, calculated from measured resistance values is 0.01001 $\pm 0.1\%$. The bridge reading of .009978 is low by 0.00003 μmho or by 0.3%.

h. Repeat measurement of standard with G MAX set at +0.1 to check different transformer tap and R_N decade resistors.

Example: For same standard of previous example, bridge G decades read 0.00999. Corrected conductance reading is 0.00998. Bridge reading is low by 0.3%.

i. To check the -0.01 and -0.1 μS G MAX ranges, connect the conductance to the bridge EXT STANDARD coaxial H and L terminals instead of to the UNKNOWN terminals. Set the MULTIPLY EXT STANDARD BY. . . switch to 1.

j. Repeat steps a through h above with G MAX set at -0.01 and at -0.1 μS . The bridge error should remain constant within $\pm 0.1\%$.

6.4.3 CONDUCTANCE CORRECTION. Since the bridge conductance error caused by inaccuracies in the two 100-kilohm resistors is a constant percent error for all

readings on all ranges, the bridge readings can be easily corrected when accuracy greater than $\pm 1\%$ is required. Determine the percent error by the calibration procedures above and apply the correction to all readings. The accuracy of the corrected readings can be increased in this way to about $\pm 0.1\%$.

6.5 DISSIPATION-FACTOR CALIBRATION.

6.5.1 DISSIPATION-FACTOR STANDARDS. A standard of dissipation factor is a calibrated capacitor of known and, preferably, very small loss. Loss is added, in the form of a calibrated resistor in series or in parallel with the capacitor, to obtain the desired calibrated value of dissipation factor, $D = \omega RC + D_d$. The dissipation factor, D_d , of the capacitor, is generally lower in a three-terminal than in a two-terminal capacitor because the loss in the supporting insulators appears only in the capacitances to ground and not in the direct capacitance of a three-terminal capacitor.

The circuit of a three-terminal capacitor with added series resistance, R, is shown in Figure 6-4. The direct capacitance between capacitor terminals H and L is C_d , and any loss in this capacitance is represented by the dissipation factor, D_d .

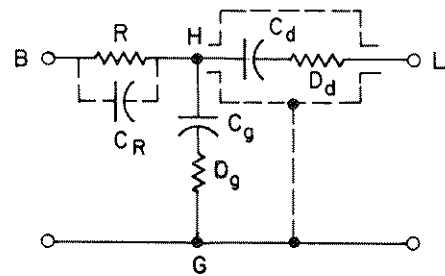

Figure 6-4. Equivalent circuit of dissipation-factor standard:

The stray capacitance from the junction, H, of R and C_d to ground or shields, G, is represented by C_g and any loss by D_g . The stray capacitance across R is represented by C_R . When the residuals C_R , D_g , and D_d can be neglected, the effective direct capacitance and dissipation factor between the terminals B and L are:

$$C'_{BL} \approx C_d \quad (6-3)$$

$$D'_{BL} \approx \omega R(C_d + C_g) \quad (6-4)$$

The errors produced by the residuals, C_R , D_g , and D_d may be determined from the more exact relations:

$$C_{BL} = C_d(1 + D_g^2)(1 + \omega^2 R^2 C_R^2) X \quad (6-5)$$

$$\left[1 - D_{BL}'^2 \frac{C_R}{C_d + C_g} + D'(D_d - D_g) \frac{C_g}{C_d + C_g} + \dots \right]$$

$$D_{BL} = (D' + D_d) \left[1 - D_{BL}'^2 \frac{C_R}{C_d + C_g} + D'(D_d - D_g) \frac{C_g}{C_d + C_g} + \dots \right] \quad (6-6)$$

Appreciable error may result from the second-order term in D'_{BL} produced in both equations by C_R , i.e.,

$$D_{BL}'^2 \frac{C_R}{(C_d + C_g)} = \omega^2 R^2 C_R (C_d + C_g) \quad (6-7)$$

This error is proportional to the stray capacitance, C_R , to the square of added resistance, R , and to the square of frequency. Since the same error appears in both C_{BL} and D_{BL} , a convenient measure of this error in D_{BL} is the percent decrease in the measured C_{BL} as R is increased from zero.

6.5.2 TYPE 1404-A AS D STANDARD. The recommended capacitor for use as a standard of dissipation factor is the Type 1404-A Reference Standard Capacitor. This capacitor has low loss, so that the dissipation factor, D_g , is less than 10 ppm at 1 kc and can usually be neglected. The coaxial H terminal of the capacitor is insulated from the case to facilitate accurate measurements of $(C_d + C_g)$ when an external resistor is added.

To calibrate and use the dissipation factor standard, proceed as follows:

a. Connect the H binding-post terminal of a Type 1615-A bridge to both the center and outer conductors of the coaxial L terminal of the capacitor with clip leads, or with the aid of a Type 874-Q2 Adaptor (Figure 6-5). Since this connects the bridge transformer voltage to the case of the capacitor, insulate the case from all grounds or other connections.

b. Connect the bridge coaxial L UNKNOWN terminal to the capacitor coaxial H terminal with a coaxial patch cord (Type 874-R22A). Since the outer conductor of this H terminal is insulated from the case, the normal connection of bridge ground for 3-terminal measurement is made to the cable shield but not to the capacitor case.

c. Measure, with the bridge set for 3 TERM, (para. 3.7.3), the capacitance $(C_d + C_g)$. The three-terminal measurement with this connection includes not only the usual direct capacitance, C_d , but also all internal stray capacitance, C_g , from the H-terminal center conductor and wiring to the case. All capacitance from the H-terminal center conductor to the terminal outer conductor and cable shield is excluded. Disconnect capacitor from bridge after measurement.

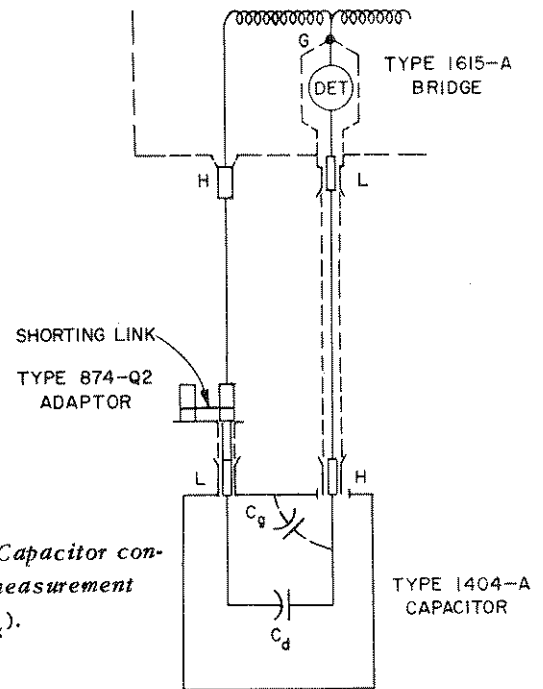

Figure 6-5. Capacitor connection in measurement of $(C_d + C_g)$.

d. Connect the bridge coaxial L terminal to the capacitor L terminal with the coaxial patch cord (refer to Figure 6-6).

e. Calculate the resistance, R , which produces the desired dissipation factor, $D = \omega R(C_d + C_g)$.

f. Use for this resistance a Type 1432 Decade Resistor or a fixed resistor in a shielding case, such as the Type 874-X Insertion Unit. If the resistor calibration is not known, measure the resistance to an accuracy better than that required of D .

g. Connect the bridge binding-post H terminal to the resistor ground terminal, which is connected to the shield or case, with a clip lead.

h. Connect the resistor low terminal to the ground terminal with shorting link or clip lead, when separate low and ground terminals are provided.

i. Connect the capacitor H terminal to the resistor high terminal with a coaxial patch cord so that the high-impedance junction of resistor and capacitor is shielded from noise sources. Use Type 874-Q9 Adaptor to connect the center conductor of the patch cord to the high (red) binding post of decade resistors and the shield to the low (gray) post.

NOTE

All capacitance from the capacitor H-terminal center conductor to cable and resistor shields is capacitance, C_R , across the resistor. It does not contribute to C_g , but does add second-order error to D (refer to Equation 6-6). To keep the error small, keep the length of coaxial cable between resistor and capacitor as small as possible.



j. From the measured or calibrated values of $(C_d + C_g)$, R , and frequency, calculate $D' = \omega R(C_d + C_g)$. The accuracy of D' depends upon the accuracy of the $(C_d + C_g)$ measurement ($\pm 0.01\%$ with the Type 1615-A Bridge), upon the accuracy of the R calibration, and upon the accuracy of the generator frequency. Since the frequency accuracy of most oscillator dial calibrations is no better than $\pm 1\%$, use a standard-frequency source or an accurate measurement of frequency when high D accuracy is required.

k. To measure the error produced by the stray capacitance, C_R , across the resistor, measure with the bridge the effective capacitance C_{BL} when the resistor is connected as shown in Figure 6-6.

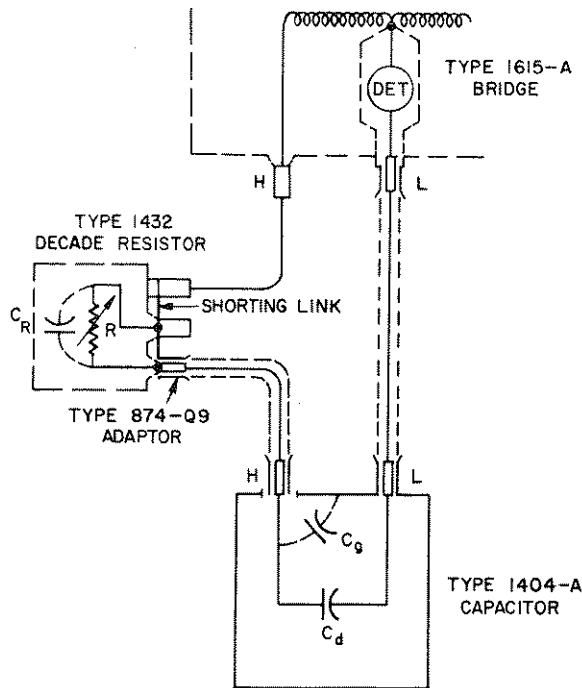

Figure 6-6. Capacitor connection for measurement of standard with capacitance C_d and dissipation factor $D = \omega R(C_d + C_g)$.

l. Measure also the capacitance when the series resistance is zero, i.e., when the decade resistor is set at zero or the fixed resistor is removed and replaced by a direct connection from bridge H terminal to capacitor H terminal. This capacitance is the usual, calibrated direct capacitance, C_d , of the Type 1404-A capacitor.

m. Calculate the error term in Equation 6-6 from the measured value of C_{BL} and C_d and the relation:

$$\text{Error} = \left[D'_{BL} \frac{C_R}{(C_d + C_g)} \right]^2 = \frac{(C_d - C_{BL})}{C_d} \quad (6-8)$$

n. When the error cannot be neglected, calculate the correct dissipation factor from the value D'

calculated in step j and the relation (from Equation 6-6):

$$D_{BL} = D' \left[1 - \frac{(C_d - C_{BL})}{C_d} \right] \quad (6-9)$$

The correct D_{BL} is lower than the value D' calculated from Equation 6-4 by the same percentage that the corresponding capacitance C_{BL} is lower than the capacitance C_d .

o. To keep the error small enough to be negligible, keep C_R small by the use of a minimum amount of cable between resistor and capacitor. Use also as low frequency as possible, since the error increases as the square of frequency.

Example: A Type 1404-A capacitor (calibrated $C_d = 1000.005$ pf) is connected in the circuit of Figure 6-6, with a series Type 1432-L Decade Resistor connected to the capacitor H terminal with a 3-foot Type 874-R22A Patch Cord. The decade is set to 20.00 kilohms (resistance accuracy $\pm 0.05\%$). The measured capacitances at a frequency of 1000.0 cps are: in step c, $C_d + C_g = 1030.478$ pf; in step k, $C_{BL} = 998.105$ pf; in step l, $C_d = 1000.006$. The calculated dissipation factor, for negligible C_R error, is $D' = 0.12950$. The error from C_R is $(C_{BL} - C_d) C_d = 0.0019$. The corrected dissipation factor is $D_{BL} = 0.12950 - 0.00025 = 0.12925$ with an accuracy of about $\pm 0.05\%$. This error of about 0.2% is produced by a capacitance C_R of about 117 pf across the 20-kilohm resistor. Since the capacitance of the 3-foot cable is 94 pf, the error could be kept below 0.1% by the use of a shorter cable. At the lower frequency of 400 cps, even with the high C_R in this example, the error would drop to 0.03%.

6.5.3 MODIFICATION OF TYPE 1404-A. Calculation of dissipation factor from $D = \omega(C_d + C_g) R$ can be simplified considerably if the constant of proportionality, $\omega(C_d + C_g)$ can be made a power of ten. The resistance, R , can then be converted to D by a change of decimal point. This can often be accomplished by the addition of trimmer capacitors from H terminal to ground to increase C_g until $(C_d + C_g) = \frac{10^x}{2\pi f}$ at the frequency of operation, f .

Example: At 1000 cps and with the direct capacitance, $C_d = 1000$ pf, if the ground capacitance, C_g , is adjusted to 592 pf, then $\omega(C_d + C_g) = 10^{-5}$ and $D = R \times 10^{-5} \times (f/1000)$.

To modify the Type 1404-A capacitor for more convenient use as a D standard:

a. Connect the capacitor to a bridge for measurement of $(C_d + C_g)$ by the procedure of para. 6.5.2. a, b, c, and Figure 6-5.

b. Connect high-quality mica or air capacitors between the center conductor of the coaxial H terminal and the case of the Type 1404-A capacitor. These may be mounted under the panel of the capacitor.

c. Adjust the added capacitance to make the measured $(C_d + C_g)$ as close as desired to $\frac{10^x}{2\pi f}$.

For example, add approximately 560 pf of capacitance to the 30-pf C_g of the Type 1404-A. For D accuracy of $\pm 0.1\%$ at 1000 cps, adjust to make $(C_d + C_g) = 1591.5$ within a few tenths pf.

d. Use this modification to simplify D calculations whenever a large number and range of D calibrations must be made. The modification does not change the direct capacitance, C_d , so that the use of the Type 1404-A Capacitor as a capacitance standard is not impaired thereby.

6.5.4 DISSIPATION-FACTOR CALIBRATION PROCEDURES. The accuracy of the bridge reading of dissipation factor depends primarily upon the accuracy of the decade resistors, R_N , and of the total capacitance $(C_N + C_D)$ in the bridge (refer to Figure 4-13). The following calibration procedures measure the combined errors from all bridge components. To separate errors in R_N from those in C_D or C_N , watch for these distinguishing characteristics:

1. An error in any resistor in the R_N decades will appear in the same decade switch on all D MAX ranges and also on all G MAX ranges. Refer to para. 6.4 for conductance-calibration procedures. For a calibration of R_N decades alone, refer to para. 6.6.

2. An error in any one of the three different range capacitances $(C_N + C_D)$ will affect primarily the corresponding D MAX range and will produce the same percent error in any reading on that range.

3. An error in the total capacitance of the bridge standards, C_N , will affect primarily the 0.01 D MAX range and will also produce an error in the bridge reading of capacitance.

To check the accuracy of the bridge readings of dissipation factor, measure a capacitor of known dissipation by the following procedure:

a. Set the bridge for three-terminal measurements at 1 kc with coaxial connections. Refer to para. 3.7.3 and Figure 3-3.

b. Connect a three-terminal capacitor with a calibrated dissipation factor, such as the Type 1404-A capacitor described in para. 6.5.2 and shown in Figure 6-6.

c. Measure the standard whose magnitude is approximately the maximum value that can be measured on each of the three D MAX ranges, i.e., with the first dec-

ade set at 9 or X, so that the resolution of the decades exceeds 0.1%. Values for the standards are listed in Table 6-4 together with the series resistance required at 1000 cps when $(C_d + C_g) = 1591.5$ pf.

d. Add 1 to the reading of the fourth decade to correct for the minimum resistance of the decade. This correction is required for 0.1% accuracy, particularly when the reading of the first decade is not above 5.

e. Use a frequency of 1000 cps that is, in general, accurate to better than 0.1%. When the external D standard has an equivalent circuit of the same form as that used in the bridge, i.e., the circuit of Figure 6-4 or Figure 4-13, the reading of the bridge D decades (not multiplied by frequency in kc) is relatively independent of frequency. When the Type 1404-A capacitor with series resistor is used as a standard of D, therefore, the 1% frequency accuracy of a Type 1311-A Oscillator is usually adequate.

f. Use a frequency lower than 1000 cps, e.g., 400 cps, when the shunt capacitance C_R across the series resistor causes an error in the D of the standard, which exceeds 1% at 1000 cps. Use a lower frequency, when, for example, a series resistor of 100 kilohms is required for a D near 1 and the shunt capacitance produces an error that is very much larger than the desired accuracy of 0.1%. The accuracy of the correction and of the otherwise negligible higher-order terms becomes important when the error is large.

g. Compare the bridge reading of D with the calibrated value of the standard. The bridge error should be no greater than $\pm(0.1\%$ of the measured value + 0.00001) at 1000 cps.

NOTE

When a calibrated D of about 0.001 is measured with D MAX at 0.01, the bridge reading will be slightly different if the balance is made with the four decades set near 0X00 instead of 1000. The change from the first to the second resistance decade changes the stray capacitance added by the resistors to C_D . These changes should be no greater than $\pm 00\ 0010$ in D reading.

**TABLE 6-4
STANDARDS FOR CALIBRATION OF D MAX RANGES**

D MAX Setting	External D Standard	Series R for $(C_d + C_g) = 1591.5$ pf
1	1	100 k Ω $\pm 0.05\%$
0.1	0.1	10 k Ω $\pm 0.05\%$
0.01	0.01	1 k Ω $\pm 0.05\%$



TYPE 1615-A CAPACITANCE BRIDGE

6.5.5 ADJUSTMENT OF BRIDGE DISSIPATION FACTOR. The bridge reading of dissipation factor can be adjusted to agree with calibrated external standards by a change in the trimming capacitors (C205-C207) for the three D ranges. These capacitors are not accessible from the bridge panel. Do not attempt an adjustment of these trimmers unless accurate standards of capacitance, resistance, and dissipation factor are available for complete bridge recalibration. Refer to para. 7.10 for adjustment procedure.

6.6 DECADE RESISTOR CALIBRATION.

6.6.1 GENERAL. In the four R_N decades of resistors in the bridge, each resistor is initially adjusted at the factory to the specified values at its terminals, so that the calibration is of resistance increments rather than of total resistance in the decades. The adjustment accuracy at dc is $\pm 0.05\%$ for the 100- and 10-ohm resistors, $\pm 0.15\%$ for the 1-ohm resistors, and $\pm 1\%$ for the 0.1-ohm resistors.

To repeat the factory calibration, the bridge shields must be removed so that a dc bridge of adequate accuracy can be connected directly to the terminals of each resistor in the decades (refer to para. 7.6 for disassembly procedures).

Calibrations of somewhat lower, but usually adequate, accuracy can be made with connections at the bridge panel. These measurements include contact resistances of the lever switches, which may vary as much as ± 0.003 ohm. The errors in the resistance steps of 0.1 ohm may, therefore, be $\pm 3\%$, and in the 1-ohm steps $\pm 0.3\%$. These errors are not significant in the specified accuracies of the bridge conductance and dissipation factor. These calibrations can be made by any of the following methods:

1. By measurements with an accurate dc resistance bridge.
2. By ac measurements made with the Type 1615-A bridge and a calibrated decade resistance box.
3. By ac measurements made with the dissipation-factor calibration capacitor and resistors.

6.6.2 WITH DC BRIDGE. To calibrate the bridge decades with a dc resistance bridge:

- a. Disconnect generator and detector from Type 1615-A bridge.
- b. Connect one terminal of the resistance bridge to the center conductor of the coaxial DETECTOR terminal on the Type 1615-A bridge.
- c. Connect the other resistance bridge terminal to the capacitance adjustment screw (accessible through hole under the panel above the DISSIPATION FACTOR controls) of the Type 1615-A (see Figure 6-2). Use the screw of the trimmer marked 0.0001 to avoid any large error from accidental misadjustment of the trimmer ca-

pacitance. All trimmer screws are connected to the junction of the R_N decades and the common side of the C_N capacitors (refer to Figure 4-13).

d. Measure each increment of resistance in the four decades, by the use of the D balance controls. The accuracy of the increments should be that of the resistors in the decade ± 0.003 ohm. The resistance with all decades set on zero will be about 0.1 ohm.

6.6.3 WITH DECADE RESISTOR. To calibrate the bridge decades with a calibrated decade resistor and an ac balance of the Type 1615-A:

- a. Connect bridge, generator, and detector for a 400-cps measurement with connection to the three-terminal coaxial terminals (refer to para. 3.7.3).
- b. Connect a calibrated decade resistor, such as the Type 1432-T, with decade steps from 100 ohms to 0.01 ohm, to the UNKNOWN coaxial H and L terminals.
- c. Connect the EXT STANDARD H terminal to one of the capacitance trimmer screws. Refer to step c in the procedure in para. 6.6.2.
- d. Set the MULTIPLY EXT STANDARD BY. . . switch to 1.
- e. Set C MAX control to 1000 pf and all CAPACITANCE decades to zero.
- f. Set D MAX control to 0.01.
- g. Set the four bridge DISSIPATION FACTOR decades (R_N) to the setting to be calibrated, e.g., 1000.
- h. Balance the bridge with the external calibrated decade resistor.
- i. Read the measured value on the external decade box.
- j. Change the bridge decade setting by one step, e.g., to 2000, and repeat balance.
- k. Take the difference of the external decade readings to obtain the measured value of increment in R_N . Measurement accuracy is that of the increments in the external decade box.
- l. Repeat for each of the ten steps in each of the four bridge decades. The accuracy of the increments should be that of the resistors ± 0.003 ohm.

6.6.4 DURING D CALIBRATION. To calibrate the bridge decades with the calibrated capacitor and decade resistor used for dissipation-factor calibration:

- a. Construct the modified Type 1404-A capacitor described in para. 6.5.3. This has a capacitance, $(C_d + C_g) = 1591.5$, that is equal to $(C_N + C_D)$ in the bridge when D MAX is set at 0.01.
- b. Connect the capacitor and calibrated decade resistor (such as Type 1432-T) to the bridge as described in para. 6.5.4 and Figure 6-6 for dissipation-factor calibration.
- c. Set D MAX control to 0.01 and C MAX to 1000 pf.

d. Set the four DISSIPATION FACTOR decades to a value to be calibrated, e.g., to 1000.

e. Balance the bridge with the external decade resistor, R , and with the bridge CAPACITANCE decades.

f. Read the measured resistance on the external decade box. At balance $\omega R_N(C_N + C_D) = \omega R(C_d + C_g)$, and, if $(C_d + C_g)$ has been made equal to $(C_N + C_D)$, then $R = R_N$.

g. Change the bridge decade setting by one step, e.g., to 2000, and repeat balance.

h. Take the difference of the external decade readings to obtain the value of the increment in R_N . Measurement accuracy is determined by the accuracy of the increments in the external decade and the accuracy of the equality of $(C_d + C_g)$ and $(C_N + C_D)$.

i. Repeat for each of the steps in the bridge decades. The accuracy of the increments should be that of the resistors, ± 0.003 ohm. A constant percent error in all measurements may be the result of a difference between $(C_d + C_g)$ and $(C_N + C_D)$.

6.7 TEST AND ADJUSTMENT OF BRIDGE ZERO.

The bridge should balance when all decades are set on zero and all external capacitances are disconnected (terminal selector set on CAL). Refer to zero-check procedure in para. 6.2.2. When the decade readings at balance are not zero, a voltage is being introduced into the detector from some source other than the bridge network. Sources of such error voltage and procedures for the location and elimination of error sources are described below.

6.7.1 GROUND LOOPS. A common source of error in a bridge is the voltage drop in the low (or ground) lead between detector and bridge that results whenever current from the oscillator can flow through this path. An equivalent circuit of bridge, detector, and oscillator connections is shown in Figure 6-7. The detector terminals should be connected only to the corners of the bridge network (B_{DG} and B_{DH}), and there should be no other connection such as that shown by the heavy dashed line from D_G to O_G , which represents a connection between oscillator and detector cases and ground terminals caused by mounting them on the same rack or connecting them to a common ground.

With only the one ground connection, B_{DG} to D_G , from detector to bridge, there is no current i_e and no error voltage V_e , and the detector measures only the unbalance voltage, V_B , of the bridge.

When the connection from D_G to O_G (shown as the heavy dashed line) is made, a portion, i_e , of the current from oscillator to bridge can return to the oscillator ground terminal, O_G , by the path $B_{OG}-B_{DG}-D_G-O_G$ and produce the voltage drop, V_e , in the lead impedance, Z . Detector deflection is then a measure of the vector

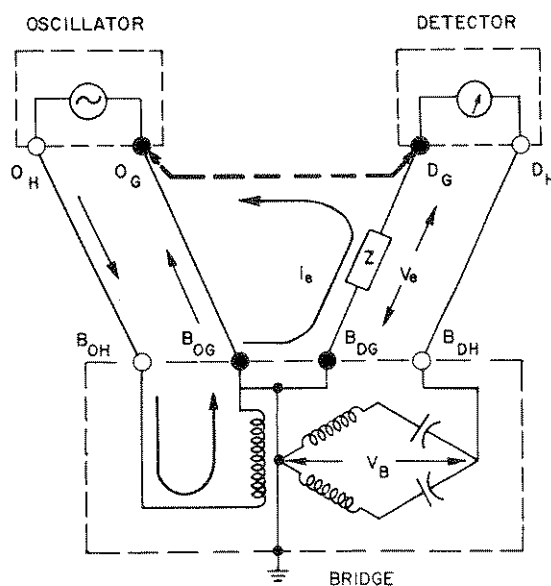

Figure 6-7. A basic ground loop.

sum of V_B and V_e , and a detector null indicates not that V_B is zero and the bridge network is balanced, but that V_B has been made equal in magnitude and opposite in phase to V_e by appropriate unbalance in capacitance and conductance in a bridge arm. All bridge readings are, therefore, in error.

This error can be detected in the Type 1615-A bridge as any change from zero of the decades when the zero-check procedure is used.

6.7.1.1 Ground Loop Confirmation. To confirm that the error comes from this source:

a. Use the zero-check procedure of para. 6.2.2. Set all decades on zero. Observe the amount of detector deflection above the noise level.

b. Reduce the oscillator output voltage with oscillator OUTPUT level controls. Detector deflection should decrease in proportion to oscillator output if current i_e comes from oscillator output. If the current source is in the oscillator circuit ahead of the level controls, the deflection may not change.

c. Turn off oscillator power. Deflection should drop to noise level if error source is in the oscillator. Error voltage may, however, enter detector by magnetic coupling rather than by current in detector lead. See further tests below.

6.7.1.2 Detector-Lead Ground-Loop Elimination. To reduce or eliminate error from current in the detector lead:

a. Connect the detector terminals to the bridge only and, whenever possible, make no other connections or grounds to the detector. The Type 1232-A battery-operated detector is particularly well-suited for isolation from all connections other than those to the coaxial INPUT terminal. Most sources of error voltage can be removed by the proper connection and location of this detector.



TYPE 1615-A CAPACITANCE BRIDGE

b. Isolate at least one low-output or input-terminal in the system from the case or ground (when the whole detector cannot be isolated, e.g., when the oscillator case is tied to the detector case, as in the Type 1620-A assembly).

In the circuit in Figure 6-8, the isolation can be made at the low terminal of the Type 1311-A Audio Oscillator OUTPUT. The output terminals are connected to a transformer winding that is insulated from the case. Do not connect in this assembly the low terminal (gray insulator) to the adjacent ground terminal with the attached link. When there is no low-impedance connection between the oscillator L and G terminals, the error current i_e is impeded by the high impedance of the capacitance, C_0 , (about 500 pf) from winding to case, and the error voltage in the detector lead is reduced to negligible magnitude.

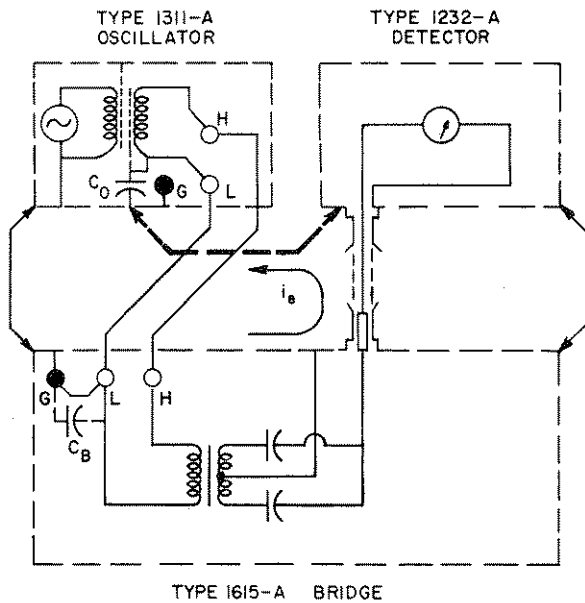

Figure 6-8. Circuit of Type 1620-A Assembly.

The GENERATOR input terminals of the bridge can be similarly isolated from bridge case when other isolation is not possible or convenient. The primary of the bridge transformer is normally connected to the bridge case by a soldered wire under the panel between the GENERATOR L terminal (gray insulator) and the adjacent GND terminal, as shown in Figure 6-8. Cut or unsolder this link to add in series with the current path of i_e the capacitance C_B of about 100 pf. Refer to Section 7 for disassembly procedures.

c. Reduce the ground current in the detector lead by the addition of a coaxial choke between detector and bridge whenever other isolation is not possible or not adequate. This choke, shown in Figure 6-9, consists of a few turns of coaxial cable wrapped on a high-permeability core, so that the cable inner and outer con-

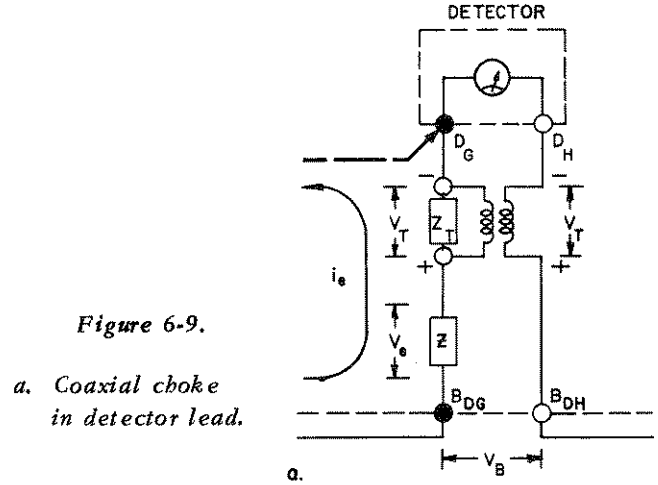

Figure 6-9. a. Coaxial choke in detector lead.

b. Coaxial choke: Coaxial cable wound on a toroidal core of high permeability.

ductors form a bifilar winding and maintain complete shielding of the inner conductor. In the circuit of Figure 6-9(a), the error current i_e is reduced by the impedance of the transformer winding; but the voltage drop, V_T , produced by that current in one winding is balanced by the equal induced voltage in the other winding, so that no detector deflection is produced by V_T . When the current is sufficiently reduced to make V_e negligible, the detector deflection is produced only by the bridge unbalance voltage, V_B . Eight turns of coaxial patch cord (Type 874-R22A) wound, as in Figure 6-9(b), on a toroidal core of 2-mil Supermalloy tape, with about 1 3/8-inch inner diameter and 1/2-inch-square cross-section produces an inductance of about 1 mh and a ground-path impedance of about 6 ohms at 1 kc.

Example: The following data were taken with the zero-check procedure: (A) on a normal Type 1620-A

assembly, (B) on an assembly with the ground link on the Type 1311-A oscillator connected to the low terminal to produce an error, and (C) with the link still connected but with a coil of turns of coaxial cable on a toroidal core added to the detector lead.

**TABLE 6-5
TYPICAL ZERO CHECK READOUTS**

Set Up	Conductance Decades	Capacitance Decades
A — normal	- .00 0000 $\mu\Omega$	0.00 000 pf
B — with ground error	- .00 0013 $\mu\Omega$	0.0(-1) 850 pf
C — with choke	- .00 0000 $\mu\Omega$	0.00 000 pf

6.7.2 MAGNETIC COUPLING. Error voltage in the detector can also be produced by magnetic fields from the oscillator, or other external sources, that induce voltage in the detector input circuit and leads. To detect and eliminate magnetic coupling between detector and external fields:

- a. Disconnect detector INPUT connection from the bridge and short-circuit the detector input terminals.
- b. Change relative positions of detector and oscillator or other suspected sources of coupling. Observe changes in detector deflection. Position detector for minimum deflection.
- c. Use a loop of hook-up wire connected to the detector INPUT as a probe for more exact location of disturbing fields.

6.7.3 ELECTROSTATIC COUPLING. Capacitive coupling of the detector to external voltage sources, when the electrostatic shielding of detector and leads is not adequate, produces error. To detect and eliminate leaks in the shielding:

- a. Use (as a probe for shield leaks) an insulated wire connected to the oscillator OUTPUT high terminal or to the bridge binding-post H terminal. Observe detector deflection as this wire is brought close to each instrument case and shielded cable.
- b. Check that cables are used for minimum leakage. Then tighten screws on instrument cases to ensure their connection to ground. Check that shield cap, Type 874-WO, is used on open bridge coaxial L terminal.

6.7.4 INTERNAL SHIELD LEAKS (3 TERMINAL). Inside the bridge, all wiring connected to transformer voltages is shielded from leaks to the detector by shield enclosures and by coaxial cables run from enclosure to enclosure. Leaks in this shielding should

produce in the bridge zero-check reading no error greater than ± 0.00003 pf.

If internal shields have been removed during bridge repair, be sure that all shields are replaced and securely connected.

6.7.5 INTERNAL LEAKS AND TRIMMER ADJUSTMENT. The additional shielding required for two-terminal measurements (see Figure 3-5) increases the possibility of leaks. With the outer shield enclosure and with the transformer-winding inner shield connected to the high side of the detector, errors can result from external voltage near the control slots in the panel and from leakage through the transformer-winding outer shield.

To compensate for residual leakage in the bridge shielding, two trimmers are provided, which permit adjustment of the two-terminal zero of the bridge. These trimmers are accessible from the front panel of the bridge through two holes marked 2 TERM ZERO ADJ, C and R, covered by the removable panel above the DISSIPATION FACTOR controls (see Figure 6-2).

In two-terminal measurements, the capacitance at the bridge terminals cannot conveniently be made zero by shielding, so that leakage cannot be identified by a simple zero check (as in the three-terminal measurements). Leakage can be detected, however, by the fact that any capacitance added by leakage remains constant, while the bridge standard capacitance changes as the transformer voltage on the unknown is varied by the C MAX control. The result is that the measured capacitance changes with a change in the C MAX setting when leakage is present.

To reduce zero error in the bridge, use the following procedures:

- a. Reduce the three-terminal zero error to a minimum by the procedures above (para. 6.7.1 *et seq.*).
- b. Set the bridge for a two-terminal measurement at 1 kc (terminal selector to 2 TERMINAL). Refer to para. 3.7.5.
- c. Use as an unknown the capacitance of the open binding posts of the bridge, about 1.3 pf. Shield the H post with a shield (such as the Type 874-Q9 Adaptor) connected to GND to prevent noise pickup by the open terminal. The magnitude of the terminal capacitance is not important as long as it remains constant during the measurements.
- d. Connect the bridge GND post to an external ground, so that no change in detector deflection results from motion of the operator's hand near the bridge decades. A change may always be expected from any motion near the unshielded H binding post.
- e. Measure the capacitance and conductance at the UNKNOWN terminals with the C MAX control at



TYPE 1615-A CAPACITANCE BRIDGE

10 pf and then with C MAX at 1 μ f. The measured capacitance should be independent of the C MAX setting (for these and for other C MAX positions, also). The measured conductance (decade reading multiplied by M) should also be constant and, in most cases, close to zero.

f. Adjust the trimmers, if there is appreciable difference in the readings with changes in C MAX. A leakage capacitance of 0.001 pf appears as a change of 000 001. pf on the 1 μ f C MAX range (where M = 1000).

Example: Measurements of the open binding posts on a bridge with trimmers not connected gave the results of Table 6-6.

**TABLE 6-6
TYPICAL READOUTS BEFORE
TRIMMER ADJUSTMENT**

(For 2-Terminal Unknown Connectors Open)

C MAX	G Decades	C Decades
10 pf	- .00 0105 (xM = 1) μ S	1.25 650 pf
1 μ f	- .00 0106 (xM = 1000) μ S	0.00 0(-1)7 pf

g. For access to trimming capacitance (C204) and conductance (R244) controls, remove left screw holding cover panel on bridge panel above DISSIPATION FACTOR controls (see Figure 6-2). Pivot cover on right screw to expose two holes marked C and R, 2 TERM ZERO ADJ, located above line of holes for capacitance trimmers. For adjustment, rotate slotted shafts through access holes with a screwdriver that has an insulated shaft. The C shaft is grounded, but the R shaft is connected to the high side of the detector.

h. Set C MAX to 1 μ f and adjust C and R to make bridge readings of capacitance and conductance equal to those measured with C MAX at 10 pf.

i. After adjustment, measure again with C MAX at 10 pf. Repeat adjustments with C MAX at 1 μ f, as required, to make readings equal.

Example: With trimmers adjusted, the bridge of the example above (step f) reads as shown in Table 6-7.

NOTE

For most accurate adjustment of conductance, the correction of ± 1 should be added to the fourth decade in the bridge reading. When this accuracy is required, the R trimmer should be set for equal detector deflection when G MAX is changed from +0.01 to -0.01 with the decades set at zero.

j. The factory adjustment is made with the bridge transformer primary connected at one end to bridge ground by the soldered jumper under the panel between the GENERATOR low terminal (gray insulator) and the adjacent GND terminal. If this ground is changed, the polarity of the voltages from the trimmers may have to be reversed. To reverse phase, change the WH-YE-GN lead on the printed switch board of switch S106 from terminal 103 (marked 3) to terminal 101 (marked 1), or vice versa. Refer to Section 7 for procedure for removing bridge case and shield.

**TABLE 6-7
TYPICAL READOUTS AFTER
TRIMMER ADJUSTMENT**

C MAX	G Decades	C Decades
10 pf	- .00 0000 (xM = 1)	1.25 930 pf
1 μ f	- .00 0000 (xM = 1000)	000 001. pf

SECTION 7

SERVICE AND MAINTENANCE

7.1 WARRANTY.

We warrant that each new instrument manufactured and sold by us is free from defects in material and workmanship, and that, properly used, it will perform in full accordance with applicable specifications for a period of two years after original shipment. Any instrument or component that is found within the two-year period not to meet these standards after examination by our factory, Sales Engineering Office, or authorized repair agency personnel, will be repaired, or, at our option, replaced without charge, except for tubes or batteries that have given normal service.

7.2 SERVICE.

The two-year warranty stated above attests the quality of materials and workmanship in our products. When difficulties do occur, our service engineers will assist in any way possible. If the difficulty cannot be eliminated by use of the following service instructions, please write or phone our Service Department (see rear cover), giving full information of the trouble and of steps taken to remedy it. Be sure to mention the serial and type numbers of the instrument.

Before returning an instrument to General Radio for service, please write to our Service Department or nearest Sales Engineering Office, requesting a Returned Material Tag. Use of this tag will ensure proper handling and identification. For instruments not covered by the warranty, a purchase order should be forwarded to avoid unnecessary delay.

7.3 SERVICE INSTRUCTIONS.

Instructions in this section cover all necessary routine trouble analysis, maintenance, and repair procedures.

NOTE

Except for those instances in which use of the entire Type 1620-A assembly is required, the detailed procedures apply to the Type 1615-A Capacitance Bridge alone.

For use with these procedures, front-panel and interior photographs, showing the location of secondary controls and replaceable detail parts, are given in Figures 7-1 through 7-5. Figure 7-6 is a complete schematic diagram. The parts list appearing in this section describes all electrical parts.

For detailed service instructions for the Type 1311-A Audio Oscillator and the Type 1232-A Tuned Amplifier and Null Detector, refer to the individual instruction books for those instruments.

7.4 MINIMUM PERFORMANCE STANDARDS.

The calibration and adjustment instructions given in Section 6 provide comprehensive checkout procedures to determine that the equipment meets minimum performance standards. They should be used to validate satisfactory completion of procedures in this section.

7.5 TROUBLE ANALYSIS. (See Figure 7-1).

Use the following procedures to locate trouble sources whenever a balance of the bridge cannot be obtained in the use of the operating procedures of Section 3 or the self-check procedures of Section 6.

Many of the analytic steps needed to find the defective circuit or detail part can be performed from front-panel terminals and will not require disassembly of the instrument. When the trouble analysis requires instrument disassembly, refer to para. 7.6 through 7.9.



TYPE 1615-A CAPACITANCE BRIDGE

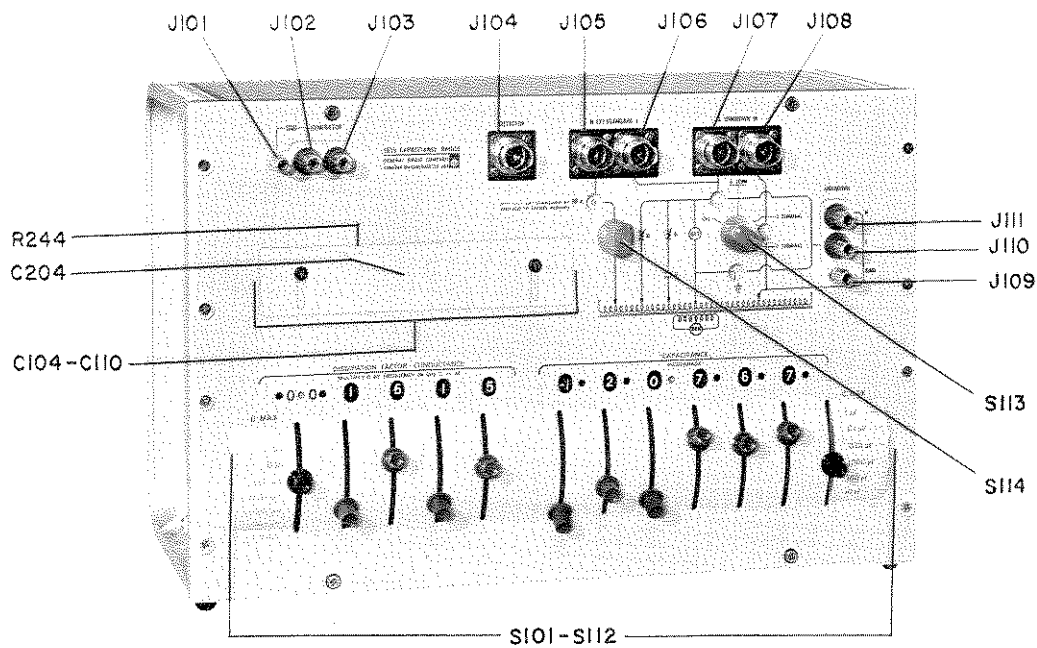

Figure 7-1. Front-panel controls and connectors, Type 1615-A. (See also Figure 7-6.)

When the source of trouble has been located by these procedures, consult our Service Department before any major repair is attempted. The instrument should be returned to the nearest General Radio Service Department for most repairs. Only minor repairs, such as the correction of obvious open or short circuits in wiring or of misadjusted switches or indicators, should be attempted unless adequate standards and trained personnel are available for complete bridge recalibration.

7.5.1 GENERATOR AND DETECTOR. When the bridge fails to operate on any position of the bridge controls, the failure may be in the bridge, the generator, or the detector. The failure is probably not in the generator or detector if the bridge can be balanced in some positions of bridge decade, C MAX, D MAX, or terminal-selector switches but not in other switch positions. To further isolate the trouble test generator and detector:

- a. Disconnect both generator and detector from the bridge.
- b. Test generator for output voltage.
- c. Test detector for response to an input voltage.

Apparent failure may result also from mistakes in operation. To avoid two common mistakes:

- (1) Reduce detector GAIN so that meter deflection does not exceed half scale before balance procedure is started. When detector input is overloaded by excessive signal from an unbalanced bridge, the meter may show no response to balance controls.
- (2) Be sure the detector is tuned to the frequency of the generator.

7.5.2 BRIDGE AND GENERATOR. When the bridge fails to operate with a generator that has been tested, test the bridge components and the wiring connected to the generator for open or short circuits.

7.5.2.1 Open-Circuit Checks. Check the bridge for open circuits with the following procedures:

- a. Connect the generator to the bridge GENERATOR terminals and set generator controls to apply 10 volts at 1 kc to the bridge.
- b. Measure the voltage at the output terminals of the generator or the GENERATOR terminals of the bridge. A low-impedance ac voltmeter, such as a volt-ohm-milliammeter, is adequate for these measurements.
- c. Measure also the voltage at the bridge UNKNOWN H and GND binding posts. This voltage should be equal to the input voltage of the bridge divided by the factor M, which varies from 1 to 1000 with the setting of the C MAX switch (S112).
- d. When there is voltage at the GENERATOR terminals but not at the UNKNOWN terminals, there is probably an open circuit in the transformer windings or leads.

e. Trace circuits with an ohmmeter to find discontinuity. Resistances to GND of all wiring to transformers should be less than 1 ohm. Refer to para. 7.6 to gain access to interior of instrument.

7.5.2.2 Short-Circuit Checks. If the generator output voltage is considerably reduced whenever the generator is connected to the bridge, there is probably a short circuit in the bridge transformer windings, or associated wiring and components. Because the resistances of

transformer windings are less than 1 ohm, an ohmmeter can seldom be used to locate short circuits. Use the following tests to locate short circuits:

- a. Set C MAX to 1000 pf and set all decades to 0.
- b. Connect generator and voltmeter to bridge GENERATOR terminals and apply 10 volts at 1 kc. If the generator voltage drops when the bridge is connected, the short is in the windings or leads to transformer T101, in the switch wiring of the decades S106-S111, in switch S114, in trimmer capacitor C204, or in the bridge H terminals. Look for solder or wire strands bridging adjacent switch terminals.
- c. Advance C MAX switch to 0.1 μ f position. If the input voltage was normal in step b but now drops, the short is in the windings or leads of transformer T102 or in switch S112.
- d. Advance C MAX switch to 1 μ f position. If the input voltage dropped in steps b and c but now shows much less drop, the short is in S112 or the H terminals. If the voltage is normal, proceed to step e.
- e. Set C MAX to 1000 pf. Move each CAPACITANCE decade switch (S106-S111) in turn from 0 to 1 and back to 0. Observe any change in input voltage.
- f. Repeat procedures of step e. with C MAX set to 100 pf and then to 10 pf.

- (1) If input voltage drops when a particular switch is moved off 0, the short is associated with that switch or with the capacitors connected to it.
- (2) If the voltage drop appears on the same decade switch for all three lower valued C MAX positions, the short is in that decade switch.
- (3) If the location of the decade switch that produces the drop moves to the left as C MAX is changed from 1000 pf to 10 pf, the short is in the capacitor or wiring connected to the decade switch.

Example: The input voltage drops when the fourth C-decade switch from the left (S109) is moved off 0 with C MAX at 1000 pf. With C MAX at 100 pf, the drop appears only when the third decade (S108) is moved. The 1-pf capacitor (C103A) and its trimmer (C107) are connected to these switches, and one of the capacitors has a short to ground.

Refer to Figures 3-2 and 7-6 to identify the capacitor connected to each decade switch on the C MAX positions.

7.5.3 BRIDGE AND DETECTOR. When the bridge fails to operate with a detector that has been tested and with all transformer voltages proven normal in the preceding tests, test for open or short circuits in the bridge wiring connected to the detector.

7.5.3.1 Three-Terminal Failure. When the bridge fails to operate on all positions of the terminal-selector switch, use the following procedures:

- a. Set terminal selector to CAL.
- b. Disconnect the detector and measure the resistance from center to outer conductor of the bridge DETECTOR terminal.
 - (1) On any of the D MAX positions of the D MAX-G MAX switch (S101), the measured resistance should be greater than 10 megohms. Much lower resistance indicates shorts in the bridge wiring, capacitors, resistance decades associated with S102-S105, or switch S113.
 - (2) On any of the G MAX switch positions the resistance should be 100 kilohms. Much higher resistance indicates an open circuit in switch S113 or in the wiring between R246 and the DETECTOR terminal.
- c. When the resistance at the DETECTOR terminal is low, measure this resistance with D MAX at 0.01 and with the four D decades set first at 0000 and then at X000.

- (1) If the measured resistance remains low, the short is between the resistors on decade switch S102 and the terminal. Test decade resistors by the procedures of para. 6.2.4.2 or 6.6.
- (2) If the measured resistance increases by about 1000 ohms, the short is on the capacitor side of the resistor R_N (see Figure 4-13) from the common side of all capacitors and trimmers to ground.

d. Measure the resistance between ground and any of the adjusting screws of the trimmer capacitors, which can be reached through the holes under the sliding panel (Figure 6-2).

e. Set the D decades first at 0000 and then at X000. If the resistance is low and increases, the short is on the detector side of resistor R_N ; if the resistance remains low, the short is on the capacitor side.

7.5.3.2 Two-Terminal Failure. When the bridge fails to operate with the terminal selector set at 2 TERMINAL but operates normally in the CAL, 3 TERM and 3 TERMINAL positions, test for short circuits across the DETECTOR terminal with the following procedure:

- a. Measure the resistance from center to outer conductor of the bridge DETECTOR terminal, with the terminal selector set at 2 TERMINAL.
 - (1) On any of the D MAX positions of the D MAX-G MAX switch, the resistance should be 1 megohm.
 - (2) On any of the G MAX positions, the resistance should be 90 kilohms.

Much lower resistance indicates a short between the two bridge shields that are separated only in 2 TERMINAL measurements (see Figure 3-5).



b. Remove case from bridge (refer to para. 7.6.2), and measure resistance. If case removal eliminates the short, it is produced by contact between case or panel and the inner shielding enclosure or subpanel. For example, a screw that attaches an end frame to the case may protrude far enough to contact the inner shield. If the short remains when the case is removed, the short may be between the two shields, around the primary of T101, or in trimmer capacitor C204. Unsolder appropriate leads to isolate these components and test for shorts.

7.5.4 LEVER-SWITCH FAILURE. When a lever switch does not operate properly in the tests of para. 6.2.4.1 and 6.2.4.2 but no short circuits are indicated by the tests of para. 7.5.2.2, there is probably an open circuit in the switch contacts or leads. Test the suspected switch by the following procedures:

a. Remove bridge case (refer to para. 7.6.2) inner shielding enclosure (para. 7.6.3), and D-G control enclosure (7.6.4), for access to switch contacts and leads.

b. Test with ohmmeter for any lack of contact between printed rotor take-off strip (on side of printed board marked 1615-0700) through the moving arms to each fixed contact strip on the opposite side of the board as the switch is rotated. Check alignment of fixed and moving contacts (refer to para. 7.8.3).

c. Test with ohmmeter for any lack of contact between the printed rotor take-off strip and the terminal of the corresponding trimmer capacitor (C104-C111) to which it should be connected through S112. (Refer to circuit diagram of Figure 7-6.)

7.5.5 IMPEDANCES AT BRIDGE TERMINALS.

7.5.5.1 GENERATOR Terminals. To test transformer T101 for defects, such as core damage, not revealed by the dc tests, measure the ac impedance at the GENERATOR terminals by the following procedure:

a. Connect to the GENERATOR terminals of the bridge an ac impedance bridge, such as the Type 1650-A Impedance Bridge.

b. Measure at these terminals the inductance of the transformer primary at 1 kc. The normal inductance is of the order of 300-400 mh. and varies with the voltage used in measurement. The Q is of the order of 2 to 3.

An inductance much lower than normal can result from a short across any section of the transformer windings or from magnetic saturation of the core by any large direct current through the windings. To demagnetize the core, apply to the primary winding a 1-kc signal of about 20 volts and slowly reduce the applied voltage to zero.

7.5.5.2 DETECTOR Terminals. To test the total bridge capacitance connected across the detector for major

defects, measure the ac impedance at the DETECTOR terminals by the following procedures:

a. Connect to the DETECTOR terminal of the bridge an ac impedance bridge, such as the Type 1650-A Impedance Bridge.

b. Measure at 1 kc the capacitance at this terminal. Typical values for a normal Type 1615-A bridge for the three D MAX switch positions are given in Table 7-1.

**TABLE 7-1
TYPICAL READINGS AT DETECTOR TERMINALS
OF TYPE 1615-A**

D MAX Setting	Capacitance	Dissipation Factor
0.01	1.76 nf.	<0.001
0.1	16.1 nf.	<0.001
1	159 nf.	<0.001

Do not use these measured capacitances for an accurate calibration of the capacitance ($C_N + C_D$) that determines bridge dissipation factor (see Figure 4-13). These terminal capacitances include wiring capacitance of the order of 200 pf that is not a part of ($C_N + C_D$).

When capacitance can be measured, but the measured value differs greatly from the normal capacitance, the trouble is probably an open circuit in one of the larger standard capacitors (C100-C102), in one of the dissipation-factor capacitors (C201-C203), or in the switch S101.

7.6 DISASSEMBLY.

7.6.1 PART LOCATION. Replaceable assemblies and detail parts are identified by reference designator in Figures 7-1 through 7-5. Descriptions of electrical parts are given in reference-designator order in the parts list in this section. Both the illustrations and the parts list are referenced in the same manner to the complete circuit schematic, Figure 7-6.

7.6.2 CASE REMOVAL. To remove the case:

a. Remove two screws at top edge, two screws at bottom edge, four screws at left edge, and four screws at right edge of panel.

b. Place bridge panel gently on padded surface and lift case with attached end frames upward and away from the panel, to which all components remain attached.

7.6.3 INNER SHIELD REMOVAL. To remove the bridge inner shielding enclosure for access to most of the wiring of the transformers, the capacitance decade switches (S106-S111), the C MAX switch (S112), and the MULTIPLY EXT STANDARD BY... switch (S114) (see Figure 7-2):

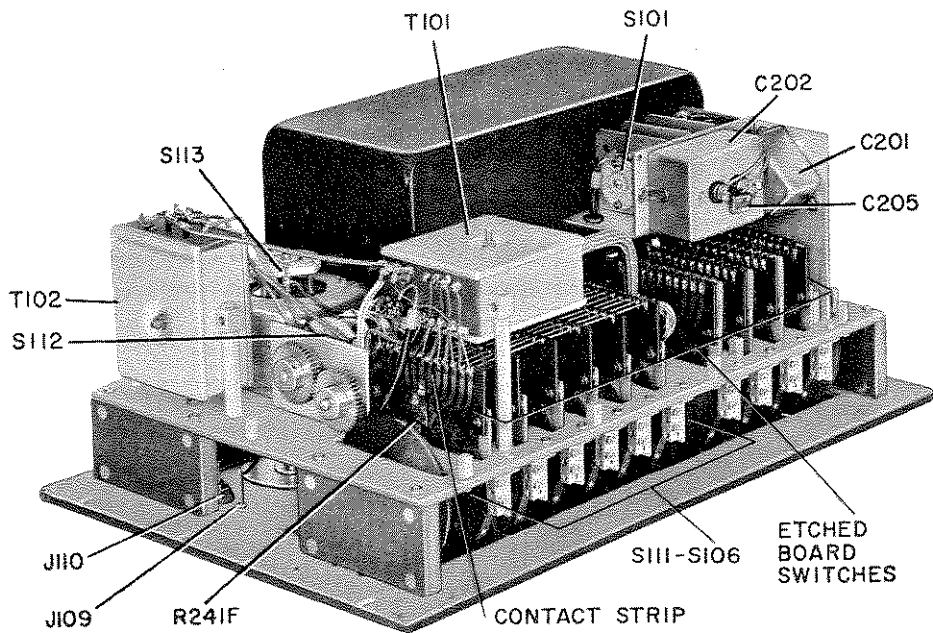

Figure 7-2. Interior (bottom, left view) of Type 1615-A with shields removed.

- a. Remove case (para. 7.6.2).
- b. Remove the ten screws along the enclosure edges next to the bridge subpanel.
- c. Lift enclosure away from the subpanel.

7.6.4 D-G CONTROL SHIELD REMOVAL. To remove the shielding enclosure of the D-G controls for access to the decade switches (S102-S105) and the attached decade resistors (R201-R240), to D-G MAX switch S101, to D-range capacitors (C201-C203 and C205-C207), G resistors (R245-R246) (see Figure 7-3):

- a. Remove case (para. 7.6.2) and inner shield (para. 7.6.3).

b. Remove three screws along the enclosure edges next to the subpanel and one screw on the enclosure side opposite the bridge panel.

- c. Lift enclosure with care away from the subpanel, to which all components remain attached.

7.6.5 TERMINAL SELECTOR SHIELD REMOVAL. To remove the shielding enclosure of the terminal selector

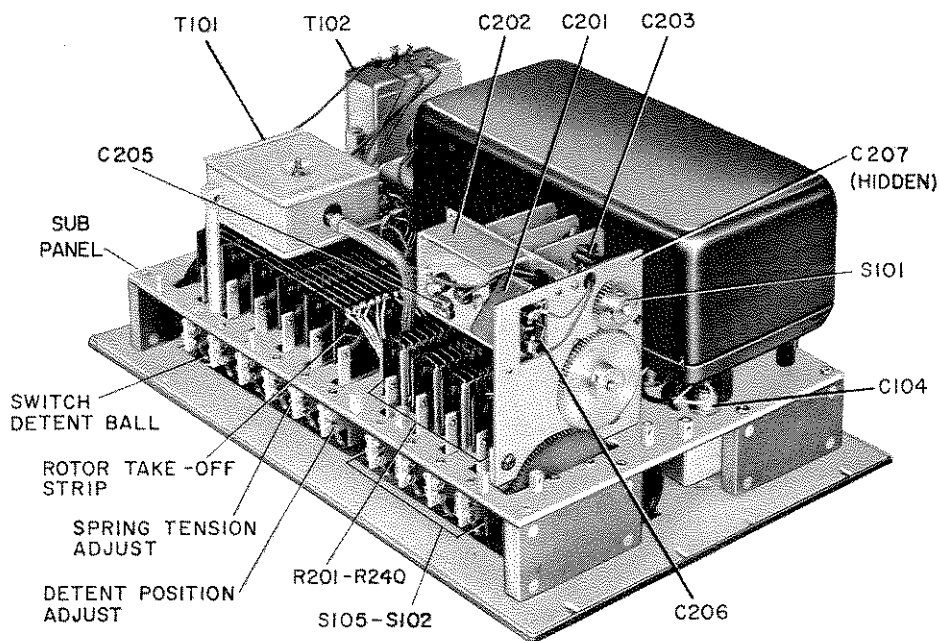

Figure 7-3. Interior (bottom, right view) of Type 1615-A with shields removed.



TYPE 1615-A CAPACITANCE BRIDGE

switch (S113) for access to the wiring of the first two wafers (see Figure 7-4):

- a. Remove case (para. 7.6.2) and inner shield (para. 7.6.3).
- b. Unsolder the three wires attached to the exposed wafer. Identify wires before removal, so that they can be replaced on correct switch terminals.
- c. Remove the two screws from the enclosure side facing this wafer.
- d. Lift enclosure with care away from the sub-panel and over the third wafer.

CAUTION

Do not attempt removal or interior access to the grey can containing the capacitance standards (C100-C103). This can is hermetically sealed. It must be returned with the bridge to the factory for any repair required.

7.6.6 SHIELDS REQUIRED FOR TEST OPERATION.

During service and maintenance operations, it is often necessary to use some of the test procedures of Section 6 after the bridge has been partly disassembled. The importance of the several shielding enclosures is described in the following as a guide to the measurements that can be performed with shields removed.

7.6.6.1 Bridge Case. For all measurements with the terminal selector at 2 TERMINAL position, bridge must be completely assembled in its case and all shields installed. All 3-terminal measurements in the other three positions of the terminal selector can be made without error with the case removed.

7.6.6.2 Inner Shielding Enclosure. Requirements are the same as for the case.

7.6.6.3 All Other Control-Shielding Enclosures. The enclosures are required for all accurate measurements. Bridge can be balanced with enclosures removed, but the detector leads are exposed to bridge and external voltage sources, and large errors may result.

7.7 CONTROL-INDICATOR ALIGNMENT.

7.7.1 REMOVAL OF DRESS PANEL. The engraved dress panel of the Type 1615-A must be removed to permit access to the number and decimal-point wheels and the other front-panel indicators. The procedure is as follows:

- a. Place the instrument with the end frames, or back wall of the case, flat on the bench so that it is self-supporting for service, with the front panel horizontal and facing up.
- b. Remove the four screws along each side of the front panel.
- c. Remove the two Phillips-head screws and flat washers on the top and bottom edges of the panel.
- d. Loosen set screws of S113 and S114 with 3/32-inch Allen wrench and remove knobs from shafts.
- e. Remove the two black knobs from the range switches (S101 and S112) and the 10 gray knobs from the balance controls (S102-S111). The knobs are kept in place by internal spring friction clips and may be pulled straight off the lever bars.

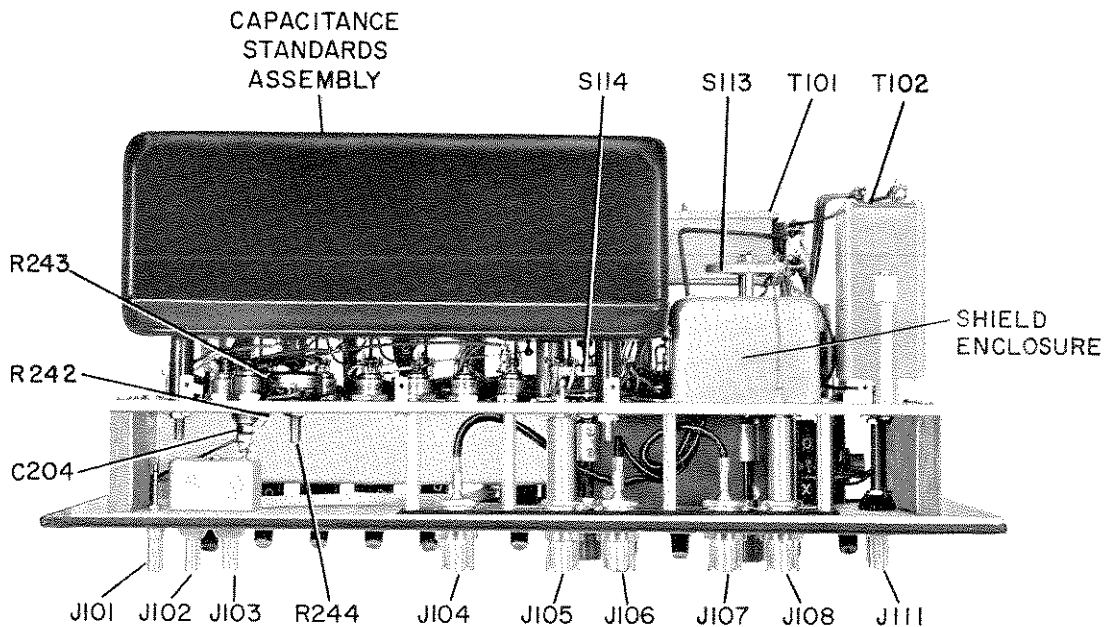

Figure 7-4. Interior (top view) of Type 1615-A with inner and D-G shields removed.

- f. Remove the trimmer access panel.
- g. Lift the dress panel away from the instrument.

7.7.2 ALIGNMENT OF TERMINAL-SELECTOR INDICATOR. If the indicator disk for the terminal-selector switch (S113) becomes loose, the proper circuit symbols can be aligned in the windows by the following procedures (see Figure 7-5):

- a. Remove the instrument dress panel by procedures of para. 7.7.1.
- b. Remove the instrument from its case and set it on the back panel of the inner shield enclosure.
- c. Loosen two set screws in hub of disk with 3/32-inch Allen wrench. One screw faces side of bridge when shaft is set at maximum clockwise (2 TERMINAL) position and the other when shaft is rotated 90° counterclockwise to a position between 3 TERM and 3 TERMINAL detents.
- d. Set shaft to maximum clockwise position.
- e. Set disk so that circuit symbols appear as in Figure 7-5.
- f. Tighten set screws, replace dress panel and check location of symbols in windows.
- g. Fasten dress panel in place. Remount case.

7.7.3 ALIGNMENT OF MULTIPLY EXT STANDARD BY... SWITCH. If the indicator disk for S114 becomes loose, the numbers can be aligned in the window by the following procedures (see Figure 7-5):

- a. Remove the instrument dress panel by procedures of para. 7.7.1.

b. Remove the instrument from its case and set it on the back panel of the inner shield enclosure.

c. Loosen two set screws in the hub of the disk with 3/32-inch Allen wrench. Setscrew faces the side of the bridge when shaft is set at maximum clockwise position (number 1 in window) and when shaft is rotated 90°, or 3 detent steps counterclockwise (number 0.7 in window).

- d. Set shaft to maximum clockwise position.
- e. Set disk so that number 1 appears in panel window.

f. Tighten one set screw, replace dress panel temporarily, and check alignment of numbers on all switch positions.

g. Tighten both set screws when alignment is correct, and also check tightness of four set screws in shaft coupler.

- h. Replace dress panel. Remount panel.

7.7.4 DECADE NUMBER ALIGNMENT. Align the numbers of each decade readout in the panel windows by the following procedures (see Figure 7-5):

- a. Remove the dress panel by procedures of para. 7.7.1.
- b. Set the lever of the decade switch at the maximum position away from the operator. The number X on the number wheel of that decade should appear in the position directly above the shaft (and in the window when dress panel is replaced), with a set-screw access hole between X and -1.

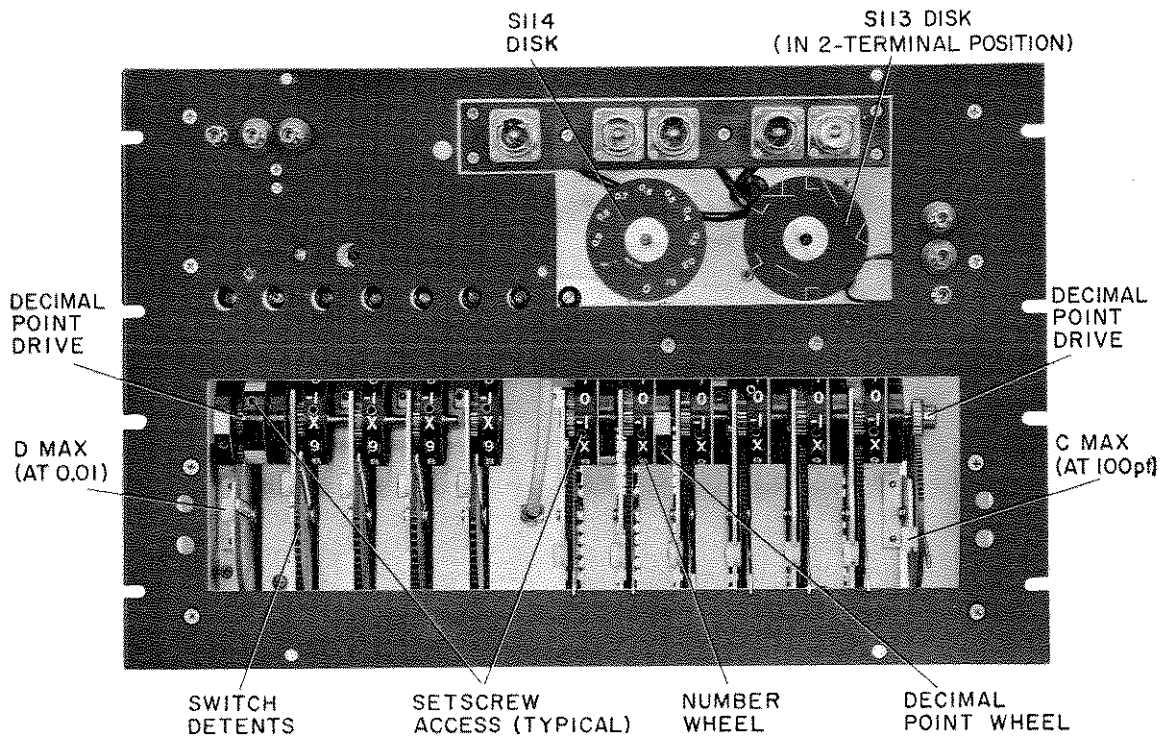

Figure 7-5. Type 1615-A bridge front panel with dress panel removed.



c. Loosen set screw with 5/64-inch Allen wrench and adjust number wheel to proper position.

d. Tighten set screw, reposition dress panel temporarily, and check alignment in the window of all numbers on the wheel. Readjust, if necessary.

e. Replace dress panel when alignment is completed.

7.7.5 DECIMAL-POINT ALIGNMENT—CAPACITANCE.

Align the six decimal points, positioned in the CAPACITANCE readout by the C MAX control, by the following procedure (see Figure 7-5):

a. Remove the dress panel by procedures of para. 7.7.1.

b. Set C MAX control to the maximum position toward the operator (10 pF position). On the first decimal-point wheel at the left, the red bar should be centered directly above the shaft (and in the window when the dress panel is replaced), with a set-screw access hole visible.

c. Loosen set screw with a 5/64-inch Allen wrench to adjust the wheel to the proper position.

d. Tighten screw, reposition dress panel temporarily, and check alignment of the red dot in the window.

e. Move C MAX control in succession to the other five positions and adjust the corresponding wheels from left to right, so that the decimal point progresses from left to right and finally appears in the window nearest the C MAX control when that switch is in the maximum position away from the operator (1 μ F position).

f. Replace the dress panel when alignment is completed.

7.7.6 DECIMAL-POINT ALIGNMENT—D-G. Align the three decimal points, positioned in the D-G readout by the D MAX-G MAX control, by the following procedure (see Figure 7-5):

a. Remove the dress panel (refer to para. 7.7.1).

b. Set the D MAX control to the maximum position away from the operator (1 position). On the right wheel, (next to the first number wheel), the red bar should be centered directly above the shaft (and in the window when the dress panel is replaced), with a set screw access hole next to the bar on the side toward the operator.

c. Loosen the set screw with a 5/64-inch Allen wrench to adjust the wheel to the proper position.

d. Tighten screw, reposition dress panel temporarily, and check alignment of the red dot in the window.

e. Move the D MAX control to the next (0.1) position and adjust, in the same way, the wider center wheel, so that the red bar with the set screw next to it (on the side toward the operator) is centered directly above the shaft.

f. Move the D MAX control to the third (0.01) position and adjust, in the same way, the left wheel so that the red bar with the set screw next to it (on the side toward the operator) is centered directly above the shaft.

g. Check, with the panel temporarily replaced, that a red decimal point appears in the second, first, and second windows for the four G MAX positions of the control in this order: +0.1, +0.01, -0.01, -0.1 μ S.

NOTE

The adjustments made on the D MAX positions also align correctly the G MAX decimal points.

h. Replace the dress panel when alignment is correct.

7.7.7 C MAX AND D-G MAX CONTROL ALIGNMENT.

Align the indexing of the black knobs on the C MAX or the D MAX-G MAX controls with the adjacent panel engraving by the following procedure (see Figure 7-5):

a. Remove the case (para. 7.6.2).

b. Remove the inner shielding enclosure (para. 7.6.3) for access to the gears that connect the C MAX lever to switch S112.

c. Remove also the D-G control enclosure (para. 7.6.4) for access to the gears that connect the D MAX-G MAX lever to switch S101.

d. Set the shaft of rotary switches S112 or S101 to maximum counterclockwise position.

e. Loosen (with a 3/32-inch Allen wrench) the two set screws in the hub of the brass gear on the switch shaft.

f. Set the black knob on the C MAX lever in line with the 10 pF engraving, or the D-G MAX lever in line with the engraved 1 at the D MAX end, and tighten set screws.

g. Move the knob to all other positions, check the alignment and readjust for best alignment on all positions.

h. Replace shields and cabinet.

7.8 LEVER-SWITCH MAINTENANCE.

7.8.1 CONTACT NOISE. Noisy or erratic detector deflection in the operation of the bridge is usually the result of corrosion or dirt accumulation on the contacts of the decade switches (S102-S111). In normal use, the contacts have a self-cleaning action, so deterioration is most evident after the bridge has been idle for an extended period. As a first remedy for noisy contacts, move the switches back and forth several times over their full range.

If the trouble persists, clean and lubricate the contacts by the following procedure (see Figure 7-2):

a. Remove bridge case (para. 7.6.2), inner shield enclosure (para. 7.6.3), and D-G control enclosure (para. 7.6.4) for access to switch contacts.

b. Remove dirt and old lubricant with a cloth or pipe cleaner moistened with clean solvent, such as alcohol, naphtha, trichlorethylene.

c. Lubricate the contacts liberally with a non-corrosive lubricant, such as Lubrico H-101 (Master Lubricant Co., Philadelphia, Pa.), or vaseline.

NOTE

A dark track left by the moving contacts on the printed board is normal and is not an indication of excessive contact wear.

7.8.2 LEVER-SWITCH DETENT ADJUSTMENT (refer also to switch test procedure of para. 6.3.4). To test and adjust torque of detents on the decade lever switches (S102-S111), use the following procedures (see Figure 7-3):

a. Remove bridge case for access to detent mechanism (para. 7.6.2).

b. Remove inner shield enclosure for access to contacts of the six CAPACITANCE decade switches (para. 7.6.3).

c. Remove shielding enclosure of D-G controls for access to contacts of the four D-G decade switches (para. 7.6.4).

d. Loosen the two 1/4-inch hex-head screws on the side of the switch brackets so that the mounting block and attached spring and ball can be pivoted around the screw nearer the subpanel with finger pressure.

e. Adjust spring tension for desired detent feel by in-or-out motion of mounting block, and retighten both screws. Check contact alignment.

f. Check that the force is not excessive at both end positions (where readout is X or -1) of the CAPACITANCE switches (S106-S111), and at the maximum end (where readout is X) of the D-G switches (S102-S105).

NOTE

The detent bumps on the switch disk on x and -1 provide increased detent force, so that these positions can be identified by the feel of the detent action.

g. Lubricate detent ball with Lubrico H-101 or equivalent.

7.8.3 LEVER-SWITCH CONTACT ALIGNMENT. Paired rotor contacts are used on all lever switches so that the switch circuit is never completely open. On the CAPACITANCE decade switches (S106-S111) a shorter contact arm is connected to a longer contact arm through a resistor of 100 kilohms. As the rotor moves out of a detent position, the shorter arm makes contact with a fixed contact strip before the longer arm loses contact; thus the transformer windings are never completely

shorted during switch operation. On the D-G decade switches (S102-S105) the two arms are directly connected to provide a shorting switch, so that the circuit of the resistance decades is never opened by switch operation.

To adjust switch contacts so that moving contact arm is aligned with a fixed contact strip when switch is in a detented position (see Figure 7-3):

a. Loosen the two Phillips-head screws that clamp the spring to the mounting block, just enough so that the spring can slide up and down behind the block.

b. Set the detent ball in one of the "valleys" and move the position of the spring so that the contact point of the longer of the two rotor arms is centered on the corresponding fixed contact strip on the printed board. The contact on the shorter arm should be centered in the insulated gap between strips.

c. Tighten the screws.

d. Check the alignment on all fixed contact strips and readjust as required.

NOTE

This adjustment of alignment should not alter the detent spring force.

e. Reset the alignment of readout numbers in the panel windows, if required, after switch-contact realignment, by the procedures of para. 7.7.

7.9 DECADE-RESISTOR CALIBRATION.

NOTE

Refer first to para. 6.6 for procedures that do not require bridge disassembly.

The accuracy of factory calibration of the four R_N decades is $\pm 0.05\%$ for the 100-ohm resistors (R201-R210) and the 10-ohm resistors (R211-R220); $\pm 0.15\%$ for the 1-ohm resistors (R221-R230); $\pm 0.5\%$ for the 0.1-ohm resistors (R231-R240). To calibrate the resistors, use the following procedures:

a. Remove the bridge case (para. 7.6.2), the inner shielding enclosure (para. 7.6.3), and the D-G control enclosure (para. 7.6.4) for access to the resistors.

b. Measure each resistor at its leads with a dc bridge of sufficient accuracy (see Figure 7-3).

c. Replace resistors that are out of calibration.

7.10 ADJUSTMENT OF D MAX RANGES.

Refer to para. 6.5 for dissipation-factor calibration procedures and to para. 6.6 for decade-resistor calibration procedures. When the decade resistors are accurate but the error of the D reading of the bridge, on one or more of the positions of the D MAX control (S101), exceeds the tolerable limit, adjust the bridge



D control components to reduce the error by the following procedures:

a. Remove the bridge case (para. 7.6.2), the inner shielding enclosure (para. 7.6.3), and the D-G control enclosure (para. 7.6.4) for access to the D-range trimming capacitors, C205-C207. See Figure 7-3.

NOTE

The enclosure of the D-G controls must be removed for adjustment of trimmers but replaced during all calibration measurements.

b. Use the calibration procedures of para. 6.5 to connect and measure the standard of dissipation factor appropriate to the D MAX range that shows the error.

c. Adjust trimmer capacitors to make error in bridge reading no greater than $\pm(0.1\%$ of the measured value + 0.000 01) at 1000 cps.

(1) For D MAX at 0.01, adjust the variable capacitor C207. If the range is not adequate, replace the mica capacitor C203 with one of smaller or larger capacitance. Be sure the shielding enclosure is replaced before measurements are made, so that the stray capacitances to shield are included in this calibration. Some trial and error will be required for accurate adjustment of C207 unless a hole is cut in the enclosure to permit adjustment while the enclosure is attached.

(2) For D MAX at 0.1, adjust the capacitance by the connection, or removal, of small mica capacitors (C206) in parallel with C201 (0.0143- μ f). Add a capacitor of about 16 pf to reduce the bridge D reading by 0.1%.

(3) For D MAX at 1, adjust the capacitance by the connection, or removal, of small mica capacitors (C205) in parallel with C202 (0.158- μ f). Add a padding capacitor of about 160 pf to reduce the bridge D reading by 0.1%.

d. Reassemble the bridge and recheck the calibration.

7.11 KNOB REMOVAL.

If it should be necessary to remove the knob on a front-panel control, either to replace one that has been damaged or to replace the associated control, proceed as follows:

a. Grasp the knob firmly with the fingers, close into the panel (or the indicator dial, if applicable), and pull the knob straight away from the panel.

CAUTION

Do not pull on the dial to remove a dial/knob assembly. Always remove the knob first.

b. Observe the position of the setscrew in the bushing, with respect to any panel markings (or at the full ccw position of a continuous control).

c. Release the setscrew and pull the bushing off the shaft. Use a hex wrench.

d. Remove and retain the black nylon thrust washer, behind the dial/knob assembly, as appropriate.

NOTE

To separate the bushing from the knob, if for any reason they should be combined off the instrument, drive a machine tap, a turn or two into bushing for a sufficient grip for easy separation.

KNOB INSTALLATION

To install a snap-on knob assembly on a control shaft:

a. Place the black nylon thrust washer over the control shaft, if appropriate.

b. Mount the bushing on the shaft, using a small slotted piece of wrapping paper as a shim for adequate panel clearance.

c. Orient the setscrew on the bushing with respect to the panel-marking index and lock the setscrew with a hex wrench.

NOTE

Make sure that the end of the shaft does not protrude through the bushing or the knob won't seat properly.

d. Place the knob on the bushing with retention spring opposite the setscrew.

e. Push the knob in until it bottoms and pull it slightly to check that the retention spring is seated in the groove in the bushing.

NOTE

If the retention spring in the knob comes loose, reinstall it in the interior notch that has the small slit in the side wall.

FEDERAL MANUFACTURERS CODE

From Federal Supply Code for Manufacturers Cataloging Handbooks H4-1
(Name to Code) and H4-2 (Code to Name) as supplemented through June, 1967.

Code	Manufacturers Name and Address	Code	Manufacturers Name and Address	Code	Manufacturers Name and Address
00192	Jones Mfg. Co., Chicago, Illinois	53021	Sangamo Electric Co., Springfield, Ill. 62705	80583	Hammarlund Co. Inc., New York, N. Y.
00194	Walsco Electronics Corp., Los Angeles, Calif.	54294	Shallcross Mfg. Co., Selma, N. C.	80740	Beckman Instruments, Inc., Fullerton, Calif.
00656	Aerovox Corp., New Bedford, Mass.	54715	Shure Brothers, Inc., Evanston, Ill.	81073	Grayhill Inc., LaGrange, Ill. 60525
01009	Alden Products Co., Brockton, Mass.	56289	Sprague Electric Co., N. Adams, Mass.	81143	Isolantite Mfg. Corp., Stirling, N. J. 07980
01121	Allen-Bradley, Co., Milwaukee, Wisc.	59730	Thomas and Betts Co., Elizabeth, N. J. 07207	81349	Military Specifications
01295	Texas Instruments, Inc., Dallas, Texas	59875	TRW Inc. (Accessories Div), Cleveland, Ohio	81350	Joint Army-Navy Specifications
02114	Ferroxcube Corp. of America, Saugerties, N. Y. 12477	60399	Torrington Mfg. Co., Torrington, Conn.	81751	Columbus Electronics Corp., Yonkers, N. Y.
02606	Fenwal Lab. Inc., Morton Grove, Ill.	61637	Union Carbide Corp., New York, N. Y. 10017	81831	Filton Co., Flushing, L. I., N. Y.
02660	Amphenol Electronics Corp., Broadview, Ill.	61864	United-Carr Fastener Corp., Boston, Mass.	81860	Barry Controls Div. of Barry Wright Corp., Watertown, Mass.
02768	Fastex Division of Ill. Tool Works, Des Plaines, Ill. 60016	63060	Victoreen Instrument Co., Inc., Cleveland, Ohio	82219	Sylvania Electric Products, Inc., (Electronic Tube Div.), Emporium, Penn.
03508	G. E. Semiconductor Products Dept., Syracuse, N. Y. 13201	63743	Ward Leonard Electric Co., Mt. Vernon, N. Y.	82273	Indiana Pattern and Model Works, LaPort, Ind.
03636	Grayburne, Yonkers, N. Y. 10701	65083	Westinghouse (Lamp Div), Bloomfield, N. J.	82389	Switchcraft Inc., Chicago, Ill. 60630
03888	Pyrofilm Resistor Co., Cedar Knolls, N. J.	65092	Weston Instruments, Weston-Newark, Newark, N. J.	82647	Metals and Controls Inc., Attleboro, Mass.
03911	Clairrex Corp., New York, N. Y. 10001	70485	Atlantic-India Rubber Works, Inc., Chicago, Ill. 60607	82807	Milwaukee Resistor Co., Milwaukee, Wisc.
04009	Arrow, Hart and Hegeman Electric Co., Hartford, Conn. 06106	70563	Amperite Co., Union City, N. J. 07087	83058	Carr Fastener Co., Cambridge, Mass.
04713	Motorola Semi-Conduct Product, Phoenix, Ariz. 85008	70903	Belden Mfg. Co., Chicago, Ill. 60644	83186	Victory Engineering Corp (IVECO), Springfield, N. J. 07081
05170	Engineered Electronics Co., Inc., Santa Ana, Calif. 92702	71126	Bronson, Homer D., Co., Beacon Falls, Conn.	83361	Bearing Specialty Co., San Francisco, Calif.
05624	Barber-Colman Co., Rockford, Ill. 61101	71294	Cannfield, H. O. Co., Clifton Forge, Va. 24422	83587	Solar Electric Corp., Warren, Penn.
05820	Wakefield Eng., Inc., Wakefield, Mass. 01880	71400	Bussman Mfg. Div. of McGraw Edison Co., St. Louis, Mo.	83740	Union Carbide Corp., New York, N. Y. 10017
07127	Eagle Signal Div. of E. W. Bliss Co., Baraboo, Wisc.	71590	Centralab, Inc., Milwaukee, Wisc. 53212	84411	TRW Capacitor Div., Ogallala, Nebr.
07261	Avnet Corp., Culver City, Calif. 90230	71666	Continental Carbon Co., Inc., New York, N. Y.	84835	Lehigh Metal Products Corp., Cambridge, Mass. 02140
07263	Fairchild Camera and Instrument Corp., Mountain View, Calif.	71707	Coto Coil Co. Inc., Providence, R. I.	84971	TA Mfg. Corp., Los Angeles, Calif.
07387	Birtcher Corp., No. Los Angeles, Calif.	71744	Chicago Miniature Lamp Works, Chicago, Ill.	86577	Precision Metal Products of Malden Inc., Stoneham, Mass. 02180
07595	American Semiconductor Corp., Arlington Heights, Ill. 60004	71785	Cinch Mfg. Co. and Howard B. Jones Div., Chicago, Ill. 60624	86684	RCA (Electrical Component and Devices) Harrison, N. J.
07828	Bodine Corp., Bridgeport, Conn. 06605	71823	Darnell Corp., Ltd., Downey, Calif. 90241	88140	Cutler-Hammer Inc., Lincoln, Ill.
07829	Bodine Electric Co., Chicago, Ill. 60618	72136	Electro Motive Mfg. Co., Wilmington, Conn.	88219	Gould Nat. Batteries Inc., Trenton, N. J.
07910	Continental Device Corp., Hawthorne, Calif.	72259	Nytronic Inc., Berkeley Heights, N. J. 07922	88419	Cornell Dubilier Electric Corp., Fuquay-Varina, N. C.
07983	State Labs Inc., N. Y., N. Y. 10003	72619	Dialight Co., Brooklyn, N. Y. 11237	88627	K and G Mfg. Co., New York, N. Y.
07999	Amphenol Corp., Borg Inst. Div., Delavan, Wisc. 53115	72699	General Instrument Corp., Capacitor Div., Newark, N. J. 07104	89482	Holtzer Cabot Corp., Boston, Mass.
08730	Vemaline Prod. Co., Franklin Lakes, N. J.	72765	Drake Mfg. Co., Chicago, Ill. 60656	89665	United Transformer Co., Chicago, Ill.
09213	General Electric Semiconductor, Buffalo, N. Y.	72825	Hugh H. Eby, Inc., Philadelphia, Penn. 19144	90201	Mallory Capacitor Co., Indianapolis, Ind.
09823	Burgess Battery Co., Freeport, Ill.	72962	Elastic Stop Nut Corp., Union, N. J. 07083	90750	Westinghouse Electric Corp., Boston, Mass.
09922	Burndy Corp., Norwalk, Conn. 06852	72982	Erie Technological Products Inc., Erie, Penn.	90952	Hardware Products Co., Reading, Penn. 19602
11599	Chandler Evans Corp., W. Hartford, Conn.	73445	Amperex Electronics Co., Hicksville, N. Y.	91032	Continental Wire Corp., York, Penn. 17405
12498	Teledyn Inc., Crystallons Div., Cambridge, Mass. 02140	73559	Carling Electric Co., W. Hartford, Conn.	91146	ITT Cannon Electric Inc., Salem, Mass.
12672	RCA Commercial Receiving Tube and Semi- conductor Div., Woodridge, N.J.	73690	Elco Resistor Co., New York, N. Y.	91293	Johanson Mfg. Co., Boonton, N. J. 07005
12697	Clarostat Mfg. Co. Inc., Dover, N. H. 03820	73899	J. F. D. Electronics Corp., Brooklyn, N. Y.	91598	Chandler Co., Wethersfield, Conn. 06109
12954	Dickson Electronics Corp., Scottsdale, Ariz.	74193	Heinemann Electric Co., Trenton, N. J.	91637	Dale Electronics Inc., Columbus, Nebr.
13327	Solitron Devices, Tappan, N. Y. 10983	74861	Industrial Condenser Corp., Chicago, Ill.	91662	Elco Corp., Willow Grove, Penn.
14433	ITT Semiconductors, W. Palm Beach, Florida	74970	E. F. Johnson Co., Waseca, Minn. 56093	91719	General Instruments, Inc., Dallas, Texas
14655	Cornell Dubilier Electric Co., Newark N. J.	75042	IRC Inc., Philadelphia, Penn. 19108	91929	Honeywell Inc., Freeport, Ill.
14674	Corning Glass Works, Corning, N. Y.	75382	Kulka Electric Corp., Mt. Vernon, N. Y.	92519	Electra Insulation Corp., Woodside, Long Island, N. Y.
14936	General Instrument Corp., Hicksville, N. Y.	75608	Linden and Co., Providence, R. I.	92678	Edgerton, Germeshausen and Grier, Boston, Mass.
15238	ITT, Semiconductor Div. of Int. T. and T., Lawrence, Mass.	75915	Littelfuse, Inc., Des Plaines, Ill. 60016	93332	Sylvania Electric Products, Inc., Woburn, Mass.
15605	Cutler-Hammer Inc., Milwaukee, Wisc. 53233	76005	Lord Mfg. Co., Erie, Penn. 16512	93916	Cramer Products Co., New York, N. Y. 10013
16037	Spruce Pine Mica Co., Spruce Pine, N. C.	76487	James Millen Mfg. Co., Malden, Mass. 02148	94144	Raytheon Co. Components Div., Quincy, Mass.
19701	Electra Mfg. Co., Independence, Kansas 67301	76545	Mueller Electric Co., Cleveland, Ohio 44114	94154	Tung Sol Electric Inc., Newark, N. J.
21335	Famir Bearing Co., New Briton, Conn.	76684	National Tube Co., Pittsburg, Penn.	95076	Garde Mfg. Co., Cumberland, R. I.
24446	G. E. Schenectady, N. Y. 12305	76854	Oak Mfg. Co., Crystal Lake, Ill.	95146	Alco Electronics Mfg. Co., Lawrence, Mass.
24454	G. E., Electronic Comp., Syracuse, N. Y.	77147	Patton MacGuyver Co., Providence, R. I.	95238	Continental Connector Corp., Woodside, N. Y.
24455	G. E. (Lamp Div), Nela Park, Cleveland, Ohio	77166	Pass-Seymour, Syracuse, N. Y.	95275	Vitramon, Inc., Bridgeport, Conn.
24655	General Radio Co., W. Concord, Mass 01781	77263	Pierce Roberts Rubber Co., Trenton, N. J.	95354	Methode Mfg. Co., Chicago, Ill.
26806	American Zettler Inc., Costa Mesa, Calif.	77339	Positive Lockwasher Co., Newark, N. J.	95412	General Electric Co., Schenectady, N. Y.
28520	Hayman Mfg. Co., Kenilworth, N. J.	77542	Ray-O-Vac Co., Madison, Wisc.	95794	Anscanda American Brass Co., Torrington, Conn.
28959	Hoffman Electronics Corp., El Monte, Calif.	77630	TRW, Electronic Component Div., Camden, N. J. 08103	96095	Hi-Q Div. of Aerovox Corp., Orlean, N. Y.
30874	International Business Machines, Armonk, N.Y.	77638	General Instruments Corp., Brooklyn, N. Y.	96214	Texas Instruments Inc., Dallas, Texas 75209
32001	Jensen Mfg. Co., Chicago, Ill. 60638	78189	Shakeproof Div. of Ill. Tool Works, Elgin, Ill. 60120	96256	Thordarson-Meissner Div. of McGuire, Mt. Carmel, Ill.
35929	Constanta Co. of Canada Limited, Montreal 19, Quebec	78277	Sigma Instruments Inc., S. Braintree, Mass.	96341	Microwave Associates Inc., Burlington, Mass.
37942	P. R. Mallory and Co. Inc., Indianapolis, Ind.	78488	Stackpole Carbon Co., St. Marys, Penn.	96906	Military Standards
38443	Marlin-Rockwell Corp., Jamestown, N. Y.	78553	Tinnerman Products, Inc., Cleveland, Ohio	97966	CBS Electronics Div. of Columbia Broadcast- ing Systems, Danvers, Mass.
40931	Honeywell Inc., Minneapolis, Minn. 55408	79089	RCA, Commercial Receiving Tube and Semi- conductor Div., Harrison, N. J.	98291	Sealortho Corp., Mamaroneck, N. Y. 10544
42190	Muter Co., Chicago, Ill. 60638	79725	Wiremold Co., Hartford, Conn. 06110	98821	North Hills Electronics Inc., Glen Cove, N. Y.
42498	National Co. Inc., Melrose, Mass. 02176	79963	Zierick Mfg. Co., New Rochelle, N. Y.	99180	Transitron Electronics Corp., Melrose, Mass.
43991	Norma-Hoffman Bearings Corp., Stanford, Conn. 06904	80030	Prestole Fastener Div. Bishop and Babcock Corp., Toledo, Ohio	99378	Atlee Corp., Winchester, Mass. 01890
49671	RCA, New York, N. Y.	80048	Vickers Inc. Electric Prod. Div., St. Louis, Mo.	99800	Delevan Electronics Corp., E. Aurora, N. Y.
49956	Raytheon Mfg. Co., Waltham, Mass. 02154	80131	Electronic Industries Assoc., Washington, D.C.		
		80183	Sprague Products Co., North Adams, Mass.		
		80211	Motorola Inc., Franklin Park, Ill. 60131		
		80258	Standard Oil Co., Lafayette, Ind.		
		80294	Bourms Inc., Riverside, Calif. 92506		
		80431	Air Filter Corp., Milwaukee, Wisc. 53218		

PARTS LIST

Ref. No.	Description	Part No.	Fed. Mfg. Code	Mfg. Part No.	Fed. Stock No.
CAPACITORS					
C100	Trimmer, 1000 pF	1615-2140	24655	1615-2140	
C101	Trimmer, 100 pF	1615-2150	24655	1615-2150	
C102	Trimmer, 10 pF	1615-2160	24655	1615-2160	
C103A	Trimmer, 1 pF				
C103B	Trimmer, 0.1 pF	1615-2100	24655	1615-2100	
C103C	Trimmer, 0.01 pF				
C104	Trimmer, 0.005 - 0.5 pF	1615-2120	24655	1615-2120	
C105	Trimmer, 0.005 - 0.5 pF	1615-2120	24655	1615-2120	
C106	Trimmer, 0.0005 - 0.05 pF	1615-2110	24655	1615-2110	
C107	Trimmer, 0.0005 - 0.05 pF	1615-2110	24655	1615-2110	
C108	Trimmer, 0.0005 - 0.05 pF	1615-2110	24655	1615-2110	
C109	Trimmer, 0.00005 - 0.005 pF	1615-2130	24655	1615-2130	
C110	Trimmer, 0.00005 - 0.005 pF	1615-2130	24655	1615-2130	
C111	Trimmer, 0.00005 - 0.005 pF	1615-2130	24655	1615-2130	
C201	Mica, 0.01430 μ F	0505-4023	24655	0505-4023	
C202	Mica, 0.1574 μ F	0505-4024	24655	0505-4024	
C203	Factory adjustment, 500 V				
C204	Trimmer, 0.005 - 0.5 pF	1615-2120	24655	1615-2120	
C205	Factory adjustment, 500 V				
C206	Factory adjustment, 500 V				
C207	Trimmer, 8 - 50 pF	4910-1170	72982	557-051, 8 to 50 pF	
JACKS					
J101	Binding Post, Metal top	0938-3000	24655	0938-3000	
J102	Binding Post, Insulated top	0938-3000	24655	0938-3000	
J103	Binding Post, Insulated top	0938-3000	24655	0938-3000	
J104					
thru	Connector, Coaxial	0874-4170	24655	0874-4170	
J108					
J109	Binding Post, Metal top	4060-0700	24655	4060-0700	
J110	Binding Post, Insulated top	4060-0700	24655	4060-0700	
J111	Binding Post, Insulated top	4060-2610	24655	4060-2610	
RESISTORS					
R201					
thru	Unit, (10) 100- Ω winding \pm 0.05%	1615-2290	24655	1615-2290	
R210					
R211					
thru	Unit, (10) 10- Ω winding \pm 0.05%	1615-2291	24655	1615-2291	
R220					
R221					
thru	Unit, (10) 1- Ω winding \pm 0.15%	1615-2292	24655	1615-2292	
R230					
R231					
thru	Unit, (10) 0.1- Ω winding \pm 1%	1615-2293	24655	1615-2293	
R240					
R241	Composition, 100 k Ω \pm 5% 1/4 W	6099-4105	75042	BTS, 100 k Ω \pm 5%	
R242	Composition, 3.3 M Ω \pm 5% 1/2 W	6100-5105	01121	RC20GF105J	5905-192-0390
R243	Composition, 100 k Ω \pm 5% 1/2 W	6100-4105	01121	RC20GF104J	5905-195-6761
R244	Potentiometer, Composition, 50 Ω \pm 10%	6000-0050	24655	6000-0050	
R245	Film, 100 k Ω \pm 0.5% 1/4 W	6351-3100	75042	CEB-T0, 100 k Ω \pm 0.5%	
R246	Film, 100 k Ω \pm 0.5% 1/4 W	6351-3100	75042	CEB-T0, 100 k Ω \pm 0.5%	
R247	Factory adjustment				
SWITCHES					
S101	Rotary	7890-2800	76854	217429-H3	
S102					
thru	Rotary	1615-3040	24655	1615-3040	
S105					
S106					
thru	Rotary	1615-3030	24655	1615-3030	
S111					
S112	Rotary	7890-2810	76854	217430-DH5C	
S113	Rotary	7890-2820	76854	217428-H3C	
S114	Rotary	7890-2830	76854	217429-H1C	
TRANSFORMERS					
T101	Toroid	1615-3100	24655	1615-3100	
T102	Toroid	1615-3090	24655	1615-3090	

b. Plug the Type 1615-P1 capacitor carefully into the EXT STANDARD coaxial terminals of the bridge, with the H and L terminals of the capacitor connected to the H and L terminals of the bridge, respectively.

c. Connect the capacitor to be measured to the H and L UNKNOWN binding posts. (The L post is connected to the GND post.)

d. Balance the bridge.

1. For capacitance:

Set the C MAX control on the appropriate range (usually 1 μf). Adjust the MULTIPLY EXT STANDARD BY. . . switch for the first decade of C balance and the six CAPACITANCE controls for the subsequent decades.

2. For loss:

Set the G MAX control on the appropriate range, + or -. Adjust the four CONDUCTANCE controls for balance.

NOTE

The D MAX ranges may be used for balance in special cases when the G MAX range is not adequate. For computation of C and G when D MAX controls are used, see Type 1615-A bridge operating instructions.

e. Record the bridge readings of C and G.

f. The capacitance and conductance of the unknown are:

1. Capacitance: The unknown capacitance in picofarads is the capacitance of the Type 1615-P1 external standard (multiplied by the reading of the MULTIPLY EXT STANDARD BY. . . dial and by the factor M) plus the capacitance indicated by the six bridge CAPACITANCE readout dials, with decimal point as indicated.

Example: C MAX set at 1 μf ($M = 1000$)
MULTIPLY EXT STANDARD BY. . . dial reads 0.3
CAPACITANCE dials read 002140. pf
Capacitance of Type 1615-P1 is 10,000.00 pf.

$$C_X = 10\,000.00 (0.3 \times 1000) + 002140. =$$

$$3\,002\,140 \text{ pf} = 3.002\,140 \mu\text{f}$$

NOTE

It is convenient and correct to read the figures (0.1, 0.2, etc) in the window of the MULTIPLY EXT STANDARD BY. . . switch as the first digit of 1, 2, . . . etc, μf in the capacitance readout. Care must be taken, however, to interpret the figure 1 in the window as 10 or X in the readout, not as 1.

2. Conductance: The unknown conductance in micromhos is the conductance of the Type

1615-P1 external standard (multiplied by the reading of the MULTIPLY EXT STANDARD BY. . . dial and by the factor M) plus the conductance indicated by the four bridge CONDUCTANCE readout dials (multiplied by the factor M).

Example: C MAX set at 1 μf ($M = 1000$)
MULTIPLY EXT STANDARD BY. . . dial reads 0.3
CONDUCTANCE dials read .00420 μS
Conductance of Type 1615-P1 is .00478 μS

$$G_X = .00478 (0.3 \times 1000) + .00420 (1000)$$

$$= 5.63 \mu\text{S}$$

3. Dissipation Factor: The dissipation factor can be calculated from the measured C (in farads) and G (in mhos) and the relation $D = G/\omega C$.

Example: For the 3 μf capacitor measured above at 1000 cps

$$D = \frac{5.63 \times 10^{-6}}{6.78 \times 10^3 \times 3.00 \times 10^{-6}}$$
$$= \frac{5.63}{18.84} \times 10^{-3} = .000\,300$$

3 CALIBRATION OF TYPE 1615-P1

3.1 PROCEDURES FOR MEASUREMENT OF CAPACITANCE AND CONDUCTANCE.

a. Set the Type 1615-A terminal-selector switch to the 2 TERMINAL position.

b. Set the MULTIPLY EXT STANDARD BY. . . switch to 0.

c. Plug the Type 1615-P1 capacitor carefully into the EXT STANDARD coaxial terminals of the bridge, with the H and L terminals of the capacitor connected to the H and L terminals of the bridge, respectively.

d. Connect to the H and L UNKNOWN binding posts of the bridge any capacitor whose capacitance is close enough to 1000 pf (or to 0.01, 0.1, 1.0 μf) to be balanced with the first CAPACITANCE control (extreme left) set in the X position and with the C MAX control set at 1000 pf (or at the 0.01, 0.1, 1 μf position). The Type 1409-F or Type 1401-D, 1000-pf standard capacitors, are convenient to use, since they plug directly into the binding-post UNKNOWN terminals of the bridge.

e. Balance the bridge with the CAPACITANCE and CONDUCTANCE controls and with the appropriate G MAX range. Do not use the D MAX ranges. Use the (-1) position of CAPACITANCE controls when the capacitance of the unknown is less than nominal.

f. After balance has been reached, record the CAPACITANCE and CONDUCTANCE readings.

Example: With a Type 1409-F Capacitor as the unknown,

$$C = X01.054 \text{ pf} \quad G = .000864 \mu\Omega$$

g. Set the MULTIPLY EXT STANDARD BY. . . switch at 0.1 instead of 0. Set the extreme left CAPACITANCE control at 0 instead of X. The bridge should return to a partial balance; because the internal 1000-pf standard has been replaced by 0.1 times the external 10,000-pf standard.

h. To complete the balance:

1. Adjust the bridge CAPACITANCE controls to restore balance. Only the last two or three should need to be moved. The first control lever must be left at 0.
2. Adjust loss with the bridge CONDUCTANCE and G MAX controls.

i. Record the new readings of C and G.

$$\text{Example: } C = 001.094 \text{ pf} \quad G = .000386 \mu\Omega$$

j. The capacitance and conductance values of the Type 1615-P1 are:

1. Capacitance: The capacitance, C_{EXT} , can be calculated from the bridge readings of the unknown capacitance, C_X , (step f) and of the difference, C_B , (step i) between the unknown and the Type 1615-P1. The relation is:

$$C_{EXT} [0.1 \times (M)] + C_B = C_X$$

where M can be 1, 10, 100 or 1000.

$$\text{Example: } C_{EXT} = (X01.054 - 001.094)/(0.1 \times 1) \\ = 9\,999.60 \text{ pf}$$

NOTE

The external standard C must be multiplied by the reading of the MULTIPLY EXT STANDARD BY. . . dial and by the factor M indicated next to the setting of the C MAX control.

A quick calculation can be made from the usual small changes in bridge readings in the following manner:

When the bridge C reading in step i is not the same as the reading of step f (except for the change from X to 0 in the first figure), the percent change in the bridge reading is the percent deviation of the Type 1615-P1 from exactly 10 times the internal 1000-pf standard. If the reading is high, the capacitance of the Type 1615-P1 is low.

Example: The bridge reads high by $(001.094 - 001.054)/1000 = 40$ ppm. The capacitance of the Type 1615-P1 is low by 40 ppm; hence

$$C_{EXT} = 9\,999.60 \text{ pf.}$$

2. Conductance: The conductance can be calculated from the conductance readings ob-

tained in step f for the unknown capacitor, G_X , and in step i for the difference between the unknown and the Type 1615-P1, G_B . The relation is:

$$G_{EXT} [0.1 \times (M)] + G_B = G_X$$

$$\text{Example: } G_{EXT} = (.000864 - .000386)/(0.1 \times 1) \\ = 0.004\,78 \mu\Omega$$

NOTE

The external standard G must be multiplied by the reading of the MULTIPLY EXT STANDARD BY. . . dial and by the factor M, indicated next to the setting of the C MAX control.

3. Dissipation Factor: The dissipation factor can, if needed, be calculated from the measured C and G using the relation $D = G/\omega C$.

Example: With the C and G measured above at 1000 cps

$$D = 0.000\,076$$

3.2 CALIBRATION EVALUATION.

From the calibrated value of capacitance and its difference from 10,000.00 pf, the value to be used for the bridge external standard capacitance can be chosen as follows:

a. If the error in the capacitance is small compared with the desired accuracy of the bridge measurement to be made with the Type 1615-P1, use the nominal capacitance of 10,000.00 pf in the calculation of unknown capacitance. In the example in step j of paragraph 3.1, the error of 40 ppm can be neglected when the measurement accuracy required is 0.1%, or even 0.01%. The dial of the MULTIPLY EXT STANDARD BY. . . switch can then be read directly as the first capacitance decade of 1 μf per step.

b. If the error is too large to neglect:

1. Use the measured value of the Type 1615-P1 capacitance in the calculation of the capacitance of the unknown. In the example above, use 9 999.60. . . pf.
2. Adjust the trimmer of the Type 1615-P1 to make the capacitance as close as desired to 10 000.00 pf and reduce the error to a negligible value. See paragraph 3.3 for adjustment procedure.

3.3 ADJUSTMENT OF TYPE 1615-P1.

a. Follow procedure of steps a through g of paragraph 3.1.

b. To complete the balance:

1. Adjust the capacitance with the trimmer of the Type 1615-P1 Capacitor. Remove the

snap-button at the end of the can and rotate with a screwdriver the exposed slotted shaft of the trimmer capacitor. The screwdriver does not have to be insulated, since the shaft is grounded. DO NOT change the setting of the bridge CAPACITANCE controls.

2. Adjust the loss with the bridge CONDUCTANCE and G MAX controls.

c. Record the new reading of G; the C reading must be the same, except for the change from X to 0 in the first figure.

Example: C = 001.054 pf G = .000386 $\mu\Omega$

d. The calibrated values of the Type 1615-P1 are:

1. Capacitance: The capacitance has been adjusted to 10 times the capacitance of the 1000-pf standard in the bridge and has the same accuracy, nominally $\pm 0.01\%$, as that standard; hence

$$C_{EXT} = 10\,000 \text{ pf } \pm 0.01\%$$

2. Conductance: The conductance calculation is the same as in step j(2) of paragraph 3.1.

3. Dissipation Factor: The dissipation-factor is the same as in step j(3) of paragraph 3.1.

Type 1615-P2

COAXIAL ADAPTOR, GR900 TO BINDING POSTS

1615-P2 Coaxial Adaptor converts 2-terminal binding-post connection on 1615 bridge to GR900 Precision Coaxial Connector for highly repeatable connections; enables measurements with adaptor to be direct-reading by compensating for terminal capacitance.

Catalog Number	Description
1615-9602	1615-P2 Coaxial Adaptor, GR900 to binding posts



1615-P2

Type 1404

REFERENCE STANDARD CAPACITOR

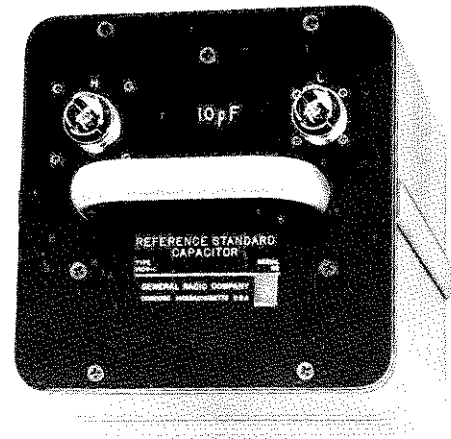

These capacitors have been designed as primary reference standards of capacitance with which working standards can be compared. The 1615-A Capacitance Bridge is particularly well suited for this purpose and can be conveniently used to calibrate accurately a wide range of working standards in terms of a 1404 Reference Standard Capacitor. A single 1000- or 100-picofarad standard is also the only standard necessary to calibrate the bridge itself.

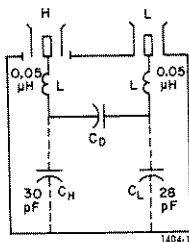

Equivalent circuit showing direct capacitance, C_D , and average values of residual inductance, L , and terminal capacitances, C_H and C_L . $C_D = 1000$ pF for 1404-A, 100 pF for 1404-B, and 10 pF for 1404-C.

specifications

Calibration: A certificate of calibration is supplied with each capacitor, giving the measured direct capacitance at 1 kHz and at $23^\circ \pm 1^\circ\text{C}$. The measured value is obtained by a comparison to a precision better than ± 1 ppm with working standards whose absolute values are known to an accuracy of ± 20 ppm, determined and maintained in terms of reference standards periodically measured by the National Bureau of Standards.

Adjustment Accuracy: The capacitance is adjusted before calibration with an accuracy of ± 5 ppm to a capacitance about 5 ppm above the nominal value relative to the capacitance unit maintained by the General Radio reference standards.

Stability: Long-term drift is less than 20 parts per million per year. Maximum change with orientation is 10 ppm and is completely reversible.

Temperature Coefficient of Capacitance: 2 ± 2 ppm/ $^\circ\text{C}$ for 1404-A and -B, 5 ± 2 ppm/ $^\circ\text{C}$ for 1404-C, from -20°C to $+65^\circ\text{C}$. A measured value with an accuracy of ± 1 ppm/ $^\circ\text{C}$ is given on the certificate.

Temperature Cycling: For temperature cycling over range from -20°C to $+65^\circ\text{C}$, hysteresis (retraceable) is less than 20 ppm at 23°C .

In combination with an accurately known external resistor, this capacitor becomes a standard of dissipation factor.

All critical parts of the plate assembly are made of Invar for stability and low temperature coefficient. After heat cycling and adjustment, the assembly is mounted in a heavy brass container, which, after evacuation, is filled with dry nitrogen under pressure slightly above atmospheric and sealed. The container is mounted on an aluminum panel and protected by an outer aluminum case. Each capacitor is subjected to a series of temperature cycles to determine hysteresis and temperature coefficients and to stabilize the capacitance.

Two locking GR874 Coaxial Connectors are used as terminals. The outer shell of one is connected to the case, but the outer shell of the other is left unconnected to permit the capacitor to be used with an external resistor as a dissipation-factor standard.

— See *GR Experimenter* for Aug 1963 and Aug 1966.

Dissipation Factor: Less than 10^{-5} at 1 kHz.

Residual Impedances: See equivalent circuit for typical values of internal series inductances and terminal capacitances.

Max Voltage: 750 V.

Terminals: Two locking GR874 coaxial connectors; easily convertible to other types of connectors by attachment of locking adaptors. Outer shell of one connector is ungrounded to permit capacitor to be used with external resistor as a dissipation-factor standard.

Accessories Required: For connection to 1615-A Capacitance Bridge, 2 Type 874-R20A or 874-R22LA Patch Cords.

Dimensions (width x height x depth): $6\frac{3}{4} \times 6\frac{5}{8} \times 8$ in. (175 x 170 x 205 mm).

Weight: Net, $8\frac{1}{2}$ lb (3.9 kg); shipping, 14 lb (6.5 kg).

Catalog Number	Description
	Reference Standard Capacitor
1404-9701	1404-A, 1000 pF
1404-9702	1404-B, 100 pF
1404-9703	1404-C, 10 pF