

# RADIO COMMUNICATIONS TEST SETS 2955A and 2955R

Part no.  
52955-910L

Part no.  
52955-321U

© Marconi Instruments Ltd. 1989

*No part of this book may be reproduced or transmitted in any form or by any means, electronic or mechanical, including photocopying, or recorded by any information storage or retrieval system, without permission in writing by Marconi Instruments Ltd.*

Printed in the UK

Manual part no. 46881-952B  
Print code : C-12/89

## CONTENTS

	Page
Preface	iii
Operating precautions	iv
Chapter 1 GENERAL INFORMATION	1-1
Chapter 2 INSTALLATION	2-1
Chapter 3-1 INTRODUCTION TO OPERATION	3-1
Chapter 3-2 TRANSMITTER TESTING	3-7
Chapter 3-3 RECEIVER TESTING	3-19
Chapter 3-4 DUPLEX TESTING	3-31
Chapter 3-5 AUDIO TESTING	3-35
Chapter 3-6 SIGNALLING CODES TESTING	3-45
Chapter 3-7 HELP KEY OPERATION	3-67
Chapter 3-8 GPIB OPERATION	3-75
Chapter 3-9 PRINTER OPERATION	3-77
Chapter 3-10 TRANSMITTER MONITORING (2955R only)	3-79
Chapter 4-1 BRIEF TECHNICAL DESCRIPTION	4-1
Chapter 5 ACCEPTANCE TESTING	5-1

## ASSOCIATED PUBLICATIONS

	Part No.
Introductory Guide ... ..	... 46881-986A
Programming Manual, H 52955-910L, Vol. 1A ... ..	... 46881-953K
Service Manual, H 52955-910L, Vol. 2 ... ..	... 46881-512Z

## PREFACE





This manual covers both the 2955A and the 2955R. The 2955R contains an off-air receiver which is not fitted to the 2955A.

## AMENDMENT STATUS

Each page bears the date of its original issue or the date and number of the latest amendment. Any changes subsequent to the latest amendment are included on Manual Change sheets coded C1, C2 etc.

## HAZARD SYMBOLS

The following symbols appear on this equipment.

Symbol	Type of hazard	Reference in Manual
	Dangerous voltages	Page iv
	Cathode ray tube	Page v
 or 	Static-sensitive components	Page v
	Input overload	Page v

## WARNINGS, CAUTIONS AND NOTES

The following terms have specific meanings in this Manual.

**WARNINGS** contain information to prevent personal injury.

**CAUTIONS** contain information to prevent damage to the equipment.

Notes contain important general information.

## INTEGRITY SEALS



If, during the warranty period of this product, an integrity seal is broken, by removing covers for example, the warranty may be invalidated.

Similarly, if a module with a broken seal is returned on an exchange basis, it will not be acceptable under the terms and conditions of the exchange service.

## OPERATING PRECAUTIONS

This product has been designed and tested in accordance with IEC Publication 348 - 'Safety Requirements for Electronic Measuring Apparatus'. To keep it in a safe condition and avoid risk of injury, the precautions detailed in the WARNINGS below should be observed. To avoid damage to the equipment the precautions detailed in the CAUTIONS should also be observed.

### WARNING - ELECTRICAL HAZARDS

**AC supply voltage.** This equipment conforms with IEC Safety Class 1, meaning that it is provided with a protective earthing lead. To maintain this protection the mains supply lead must always be connected to the source of supply via a socket with an earthing contact. Make sure that the earth protection is not interrupted if the supply is connected through an extension lead or an autotransformer.

Before fitting a non-soldered plug to the mains lead cut off the tinned end of the wires, otherwise cold flowing of the solder could cause intermittent contact.

Do not use the equipment if it is likely that its protection has been impaired as a result of damage.

**Fuses.** Note that there is a supply fuse in both the live and neutral wires of the supply lead. If only one of these fuses should rupture, certain parts of the equipment could remain at supply potential.

Make sure that only fuses of the correct rating and type are used for replacement. Do not use mended fuses or short-circuited fuse holders.

To provide protection against breakdown of the supply lead, its connectors (and filter if fitted), an external supply fuse with a continuous rating not exceeding 6 A should be used in the live conductor (e.g. fitted in the supply plug).

**Removal of covers.** Disconnect the supply before removing the covers so as to avoid the risk of exposing high voltage parts. If any internal adjustment or servicing has to be carried out with the supply on, it must only be performed by a skilled person who is aware of the hazard involved.

Remember that capacitors inside the equipment, including any supply filter capacitors, may still be charged after disconnection of the supply. Those connected to high voltage points should be discharged before carrying out work inside the equipment.

This applies particularly to the EHT circuit for the cathode ray tube which must be discharged by repeatedly shorting the final anode lead to the chassis or by using a bleed resistor. The residual charge on the CRT itself should also be removed by shorting the anode connector to the chassis.

### WARNING - OTHER HAZARDS

Parts of this equipment are made from metal pressings, therefore it should be handled with due care to avoid the risk of cuts or scratches.

Some of the components used in this equipment may include resins and other materials which give off toxic fumes if incinerated. Take appropriate precautions, therefore, in the disposal of these items.

**Cathode ray tube.** When exposing or handling the tube, take care to prevent implosion and possible scattering of glass fragments. Handling should only be carried out by experienced personnel and the use of a safety mask and gloves is recommended. A defective tube should be disposed of in a safe manner by an authorized waste contractor.

### CAUTION - STATIC SENSITIVE COMPONENTS

This equipment contains static-sensitive components which may be damaged by handling. Refer to the Service Manual for handling precautions.

## Chapter 3-1

### INTRODUCTION TO OPERATION

#### FRONT PANEL

[10] SINGLE SWEEP key. Selects only one sweep of the oscilloscope trace to occur after a trigger and implements the storage oscilloscope facility. Resets the sweep if it is part way through. Also, this is used as a soft key for bar charts to change between autoranging (shown by A) and holding the range (shown by H) when a particular bar chart has been selected (using [12]).

[11] REP SWEEP key. Selects repetitive sweeping of the oscilloscope trace on auto trigger.

[12] HORIZ keys. Change the oscilloscope horizontal scale in time per division. Also, the upper key is used as a soft key to select (by pressing once or more) a particular bar chart (shown by A or H flashing) to change between autoranging and holding the range (by using [10] and then this upper key again).

## Chapter 3-3

### RECEIVER TESTING

#### RF GENERATOR

##### Modulation setup

To control the external modulation, press the EXT MOD key. The EXTERNAL MOD INPUT frequency and level appear. To enable and disable the external modulation, use the key which is arrowed by EXT MOD and OFF alternately.

## Chapter 3-10

### TRANSMITTER MONITORING (2955R ONLY)

#### CONTROLS AND CONNECTORS

- [21] RF IN/OUT BNC socket. For the Telescopic Antenna or another antenna or for a very low-power transmitter or probe. The maximum input to the sensitive receiver is limited to 1 W. Impedance 50  $\Omega$ .
- [22] RF IN/OUT N socket. For higher level inputs. The maximum input to the sensitive receiver is limited to 75 W. Impedance 50  $\Omega$ .
- [25] BAND PASS key. Selects a 0.3 to 3.4 kHz band-pass filter or an external filter.

EQUIPMENT ... 2955A and 2955R  
TITLE ..... RADIO COMMUNICATIONS TEST SETS  
PART NOS. ... 52955-910L (2955A)  
52955-911J (2955A without GPIB)  
52955-321U (2955R)  
52955-326F (2955A French)  
52955-327G (2955A Spanish)

-----  
**MANUAL CHANGE**

On the title page, substitute the above part numbers and, under the given headings, substitute the following -

**Chapter 1**

**GENERAL INFORMATION**

**PERFORMANCE DATA**

**Off-air receiver (2955R only)**

Sensitivity: 2  $\mu$ V for 10dB SINAD in 12 kHz bandwidth  
from 1 MHz to 1000 MHz for 3.5 kHz  
deviation in a psophometric bandwidth.

Maximum input level: Deleted.

Indicated signal strength range: 1  $\mu$ V to 30 mV into BNC socket,  
10  $\mu$ V to 300 mV into N socket.

Damage level in Tx monitor mode: >1 W into BNC socket,  
>75 W into N socket.

**Chapter 2**

**INSTALLATION**

**POWER REQUIREMENTS**

The required supply fuses (time-lag) are as follows:-

AC power supply	2955A	2955R
105 to 120 V	1.0 or 1.6 A	1.6 A
210 to 240 V	0.5 or 0.8 A	0.8 A

RADIO COMMUNICATIONS TEST SETS

2955A and 2955R

- Part no. 52955-910L (2955A)
- 52955-911J (2955A without GPIB)
- 52955-321U (2955R)
- 52955-326F (2955A French)
- 52955-327G (2955A Spanish)
- 52955-328V (2955R French)
- 52955-329S (2955R Spanish)

Your instrument has been fitted with software version 4. This has some improvements and additional features as follows:-

- (a) In the TRANSMITTER MONITOR mode, the POSITION ↔ control acts as a SQUELCH control.
- (b) Transmitter power readings can be displayed in W or in dBm by using the dBm key.
- (c) The maximum RF GEN FREQ is 1060 MHz.
- (d) Inverted POCSAG is available.
- (e) The POCSAG default frequency is 152.24 MHz when the TONE STANDARD has been set to USA and stored by switching off the instrument.

We are at present reprinting the Operating Manual, the Programming Manual and the Introductory Guide with appropriate revision and other improvements.

If you wish to have the updated printing(s) when they become available, please mark which you require, fill in your address and return the form.

-----

To: Technical Publications Department  
 Marconi Instruments Limited  
 Longacres, St Albans, Herts. AL4 0JN  
 England

When available, please send a copy of

- |                  |                    |                    |
|------------------|--------------------|--------------------|
| 2955A and 2955R  | 2955A and 2955R    | 2955A and 2955R    |
| OPERATING MANUAL | PROGRAMMING MANUAL | INTRODUCTORY GUIDE |
| Dec. 90 (Am. 3)  | Dec. 90 (Am. 3)    | Dec. 90 (Am. 4)    |

to Name . . . . .

Address . . . . .

. . . . .

. . . . .

Telephone . . . . .

.....



## **CAUTION – INPUT OVERLOAD**

When testing a transmitter, an input overload is indicated by the message 'REMOVE RF INPUT' and an audible warning. Failure to respond could result in damage to the equipment.

## **CAUTION – TILT FACILITY**

When the instrument is in the tilt position, it is inadvisable, for stability reasons, to stack other instruments on top of it.

## COMPATIBILITY WITH 2955

The 2955 has been superseded by the 2955A which has a number of improvements. If you are familiar with the 2955, you should beware of the following differences:-

- (1) The 2955 has RF signal generator output level ranges which are 5 dB lower than those of the 2955A. Therefore, the lowest possible setting is 5 dB higher on the 2955A. See under 'Performance data' in Chap. 1.
- (2) On the 2955, the fifth and sixth blue MODE keys are BAR CHART and SCOPE. On the 2955A, the fifth is cleared for another purpose so its function and that of the sixth are combined in the SCOPE/BAR key. See under 'Front panel' in Chap. 3-1.
- (3) On the 2955, there are 37 stores. On the 2955A, there are 26 stores which each has a larger capacity. With early software, the 2955A appeared to accept numbers higher than 26 but this has been corrected from software issue 6. See under 'Front panel' in Chap. 3-1.
- (4) The 2955 has one variable AF/modulation generator which is set by using AF GEN and SET MOD. The 2955A has two fully-variable AF/modulation generators. See under 'AF generators' in Chap. 3-2 and under 'RF generator' in Chap. 3-3.
- (5) On the 2955, two tones and sub-audible are selected on the TONES STANDARD MENU. On the 2955A, these are generated by using the second AF generator as selected on the main display.
- (6) In DUPLEX test mode on the 2955, the modulation frequency is automatically set to 1 kHz. On the 2955A, if any other modulation frequency has been set in DUPLEX mode, this is retained if DUPLEX mode is re-selected after using another mode. The modulation frequency is changed to 1 kHz when distortion, SINAD or S/N is selected.
- (7) On the 2955, there is one page of sequential tones. On the 2955A, there are three pages which allow up to 33 tones to be used. Each page of 11 tones is selected by the NEXT PAGE soft key. See under 'Sequential tones operation' in Chap. 3-6.
- (8) On the 2955, the fifth from last sequential tone can be extended. On the 2955A, any one of the sequential tones can be extended. See under 'Sequential tones operation' in Chap. 3-6.
- (9) On the 2955, there are six settings under CHANGE PARAMETERS on the HELP menu. On the 2955A there are six more settings. See under 'Parameters' in Chap. 3-7.
- (10) As supplied, each 2955 is programmed either for EEA (European) or for EIA (North American). On the 2955A, this is selected under CHANGE PARAMETERS on the HELP menu. See TONE STANDARD selection under 'Parameters' in Chap. 3-7.
- (11) For use in GPIB mode with a Cellular or Multi-system Adapter or when using GPIB software which has been written for the 2955, the 2955A can be set to emulate the 2955. See GPIB MODE selection under 'Parameters' in Chap. 3-7.

## Chapter 1

# GENERAL INFORMATION

	Page
Introduction ... ..	1-1
Special features ... ..	1-4
Transmitter testing ... ..	1-4
Receiver testing ... ..	1-4
Duplex testing ... ..	1-5
Performance data ... ..	1-6
RF signal generator ... ..	1-6
Modulation generator... ..	1-7
Audio generators ... ..	1-9
RF frequency meter ... ..	1-10
RF power meter... ..	1-11
Modulation meter ... ..	1-12
Noise and distortion meter... ..	1-14
AF frequency meter ... ..	1-14
AF voltmeter ... ..	1-15
Internal frequency standard ... ..	1-15
Digital storage oscilloscope ... ..	1-16
Selcall (sequential tone) encoder and decoder ... ..	1-16
Additional features ... ..	1-17
General ... ..	1-19
Accessories ... ..	1-20

Fig.

1-1 Radio Communications Test Set 2955A ... .. 1-2

## INTRODUCTION

Radio Communications Test Set type 2955A combines all the measurement facilities required for testing mobile radio transceivers in the range up to 1000 MHz. It is a compact self-contained unit designed for bench or mobile use and can be considered as a combination of the following instruments:-

- RF frequency meter.
- AF frequency meter.
- RF signal generator.
- AF generators (two).
- RF power meter.
- AF and DC voltmeter.
- Modulation meter.
- Distortion meter.
- Signal to noise (S/N or SINAD) meter.
- Digital storage oscilloscope.
- Sequential tones decoder and encoder.
- DTMF decoder and encoder.
- DCS decoder and encoder.
- POCSAG radio pager encoder.

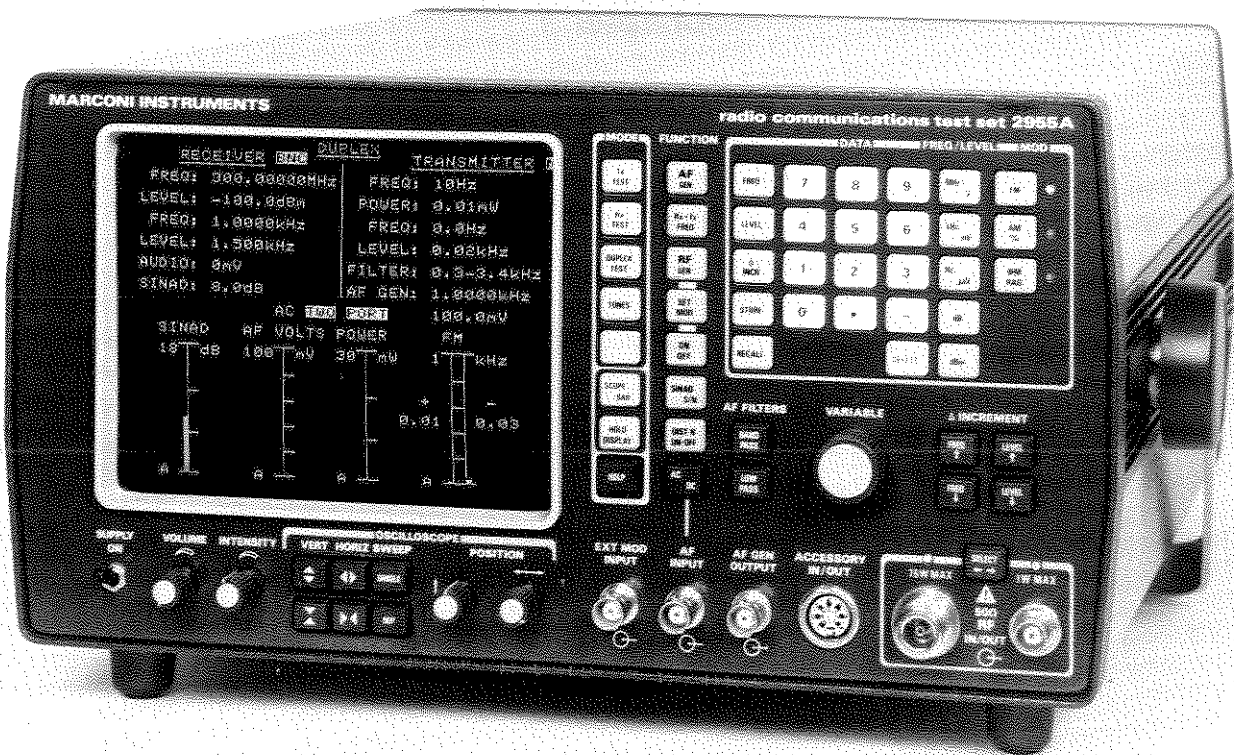

Fig. 1.1 Radio Communications Test Set 2955A

Push-button selection makes all the necessary interconnections for each measurement, eliminating the need for the many interconnections required when separate instruments are used. Function selection and data entries are made on a colour-coded keyboard with the operating sequence logically arranged from left to right. Instrument operation is greatly enhanced by the CRT display which provides prompts during data entry and guidance during operating sequences while also showing the instrument settings and measurement results. Analogue measurements are displayed by an oscilloscope with repetitive sweep, single shot and freeze facilities, as well as by five autoranging bar charts.

Radio Communications Test Set type 2955R is identical to the 2955A except that the 2955R also contains a sensitive receiver for off-air monitor testing of transmitters.

**Frequency meters.** As there are two frequency counters, simultaneous AF and RF frequency readings can be displayed. Ranges and resolutions are respectively from 20 Hz to 20 kHz at 0.1 or 1 Hz and from 1.5 to 1000 MHz at 1 or 10 Hz. Either an internal or an external frequency standard can be used.

**Signal generator.** The signal generator can be amplitude, frequency, or phase modulated, internally or externally, the internal modulating signal being obtained from the AF generators. Amplitude modulation is variable up to 99% for carrier frequencies from 0.4 to 500 MHz. FM deviation can be set from 0 to 25 kHz and  $\Phi$ M deviation from 0 to 10 radians. Transmitter and receiver measurements can be made from a common N type connector. The generator's BNC socket is automatically protected against reverse power overloads.

**Modulation meter.** Automatic frequency tuning and levelling of the modulation monitor provide accurate measurements of AM, FM and  $\Phi$ M. Because of the independent tuning, modulation measurements can be made on duplex systems. The modulation can be observed on an oscilloscope and its symmetry checked from the peak and trough values displayed on a dual bar chart. The demodulated output is available at a rear panel socket. Provision is made for audible monitoring using the built-in loudspeaker or by an external loudspeaker or headphones.

**RF power meter.** The absorption RF power meter measures up to 75 W continuously or up to 150 W for short periods over a frequency range of 1.5 to 1000 MHz. Power levels can be observed on an autoranging bar chart in addition to the digital readout. The connection of the a throughline power meter (available as an optional accessory) extends the capability of the instrument by enabling measurements of forward power, reverse power and VSWR to be made.

**AF generators.** The two AF generators provide a range of frequencies from 20 Hz to 20 kHz for single-tone or two-tone testing. The audio output is available at a front panel socket and the generators also provide the internal AM, FM and  $\Phi$ M for the RF signal generator. A combined 600  $\Omega$  Balanced to Unbalanced Converter and 20 dB Attenuator is available as an optional accessory.

**AF voltmeter.** Operating in the range 20 Hz to 20 kHz, the true RMS audio frequency voltmeter has provisions for measuring AF or AF plus the DC component. Band-pass and low-pass filters can be selected. Level can be observed on an autoranged bar chart.

**Distortion and S/N or SINAD meters.** The AF distortion meter and the associated SINAD meter operate at a frequency of 1 kHz supplied by one of the AF generators. The bar chart displays are autoranged at 10% and 30% (for distortion and S/N) and at 18 dB and 50 dB (for SINAD). The CCITT and C-message filters (available as optional accessories) enable psophometrically weighted measurements to be made.

**Sequential tones decoder and encoder.** For testing selective calling tones encoding and decoding equipment, the instrument is capable of receiving and generating five defined tone frequency standards plus a user-defined standard. Provision is made to receive and to send sequences of up to 33 tone frequencies. For transmitter testing, each received tone is compared with the standard frequency allocations which is held in memory and, if it is within the limits, its tone number and % frequency error are displayed. For receiver testing, the tones can be generated in single step, tone burst or continuous cycle. There is a revertive tones facility whereby tones are sent to a receiver and the the answering sequence is decoded.

**DTMF decoder and encoder.** There are similar facilities for testing DTMF encoding and decoding equipment.

**DCS decoder and encoder.** There are similar facilities for DCS encoding and decoding equipment.

**POCSAG radio pager encoder.** The instrument can be used to check the response of a pager to an RF signal modulated with the pager's address and an appropriate message. Deliberate errors can be created in the outgoing signal.

**GPIB interface unit.** This unit allows the instrument to form part of an automatic test system. The GPIB additionally enables a display to be configured to the user's own requirements using a comprehensive character set. The GPIB also enables an optional 24-column ticket printer to be used.

**Off-air receiver.** In the 2955R only, there is a sensitive receiver which allows off-air monitoring of transmitters.

**Calibration and testing.** Routine calibration has been kept to a minimum. Calibration factors are stored in a non-volatile memory and can be accessed with a secure access code from the front panel keys or by the GPIB, permitting rapid recalibration. A built-in self test facility can be called up whenever it is required. This enables faults to be identified to major module level or to groups of components.

## SPECIAL FEATURES

### Transmitter testing

Setting:	Press TX TEST key to select this test mode.
Auto-tuning:	Typically under 3 seconds to acquire and measure RF frequency, RF power, modulation frequency and level and modulation distortion.
Manual tune:	Displays positive and negative frequency offset from carrier. 3 digits and decimal point indicate most significant error.
Sequential tones:	Decodes CCIR, ZVEI, DZVEI, EEA or EIA and user-defined menu. Provides tone number, frequency and % error for up to 33 tones. Tone deviation and duration can be monitored using the digital storage oscilloscope in the transmitter test mode.
RX=TX key:	Presets the RF signal generator frequency for the receiver test mode to that shown in the transmitter test mode.
HOLD DISPLAY key:	Freezes screen settings and readings facilitating high RF power measurements and hard copy printout of the TRANSMITTER TEST, RECEIVER TEST, DUPLEX test or AUDIO TEST displays.

### Receiver testing

Setting:	Press RX TEST key to select this test mode. Default settings of RF level, modulation frequency and level reduce function test time.
Signal generator:	Output level accuracy $\pm 2$ dB over entire frequency, temperature and attenuator ranges. Level units keyboard selectable either dBm, dB $\mu$ V or $\mu$ V. Software menu allows user to switch between PD and EMF levels.
Distortion and S/N meters:	User-settable default condition allows either SINAD or S/N readings, a dedicated key is provided to toggle the setting.

Sequential tones: Encodes CCIR, ZVEI, DZVEI, EEA or EIA and user-defined frequencies.  
User can send up to 33 tones in any standard continuously, by tone step or in a burst. A facility allows for tones to be extended.

## Duplex testing

Setting: Press DUPLEX TEST key to select this test mode.

Modulation meter: Independent modulation meter and RF signal generator allows any frequency offset for duplex radio or cross-band repeater testing.

Sequential tones: Decodes and encodes CCIR, ZVEI, DZVEI, EEA or EIA and user-defined menu.  
User can send up to 33 tones in any standard continuously, by tone step or in a burst. A facility allows for tones to be extended.

## PERFORMANCE DATA

### RF signal generator

Output impedance: 50  $\Omega$  nominal.

VSWR: N socket; <1.2:1 to 500 MHz.  
<1.35:1 to 1000 MHz.  
BNC socket; <2.2:1 to 1000 MHz.

### Frequency

Range: 0.4 MHz to 1000 MHz.

Resolution: 50 Hz up to 530 MHz.  
100 Hz up to 1000 MHz.

Indication: 8 digit display.

Setting: Keyboard entry; step change variation by increment/decrement keys and rotary control.

Accuracy: As internal standard.

### Output level

#### Range

N socket: -135 to -15 dBm (0.04  $\mu$ V to 40 mV).  
BNC socket: -115 to +5 dBm (0.4  $\mu$ V to 400 mV).  
One-port duplex: -140 to -21.5 dBm (0.0224  $\mu$ V to 18.85 mV).  
Two-port duplex: -115 to -15 dBm (0.4  $\mu$ V to 40 mV).

Resolution:	0.1 dB.
Indication:	4 digits (dBm/ $\mu$ V, PD/EMF and dB $\mu$ V).
Accuracy:	$\pm 2$ dB for levels above $-127$ dBm.

**Spectral purity**

FM on CW:	<30 Hz up to 520 MHz, <60 Hz up to 1000 MHz. (0.3 to 3.4 kHz weighted RMS). Typically 8 Hz up to 250 MHz, 15 Hz up to 500 MHz, 30 Hz up to 1000 MHz.
Harmonics:	Harmonics specified in band 0.4 to 1000 MHz only. < $-20$ dBc up to 1.5 MHz. < $-25$ dBc 1.5 MHz to 250 MHz. < $-20$ dBc 250 MHz to 1000 MHz.
Sub-harmonics:	None up to 530 MHz, < $-25$ dBc up to 1000 MHz.
Spurious signals:	Carrier up to 88 MHz- < $-45$ dBc below 110 MHz. < $-35$ dBc above 110 MHz. Carrier up to 1000 MHz < $-60$ dBc.
S/N at 20 kHz:	< $-106$ dB/Hz to 500 MHz. < $-100$ dB/Hz to 1000 MHz.
RF carrier leakage:	<0.2 $\mu$ V PD generated in a 50 $\Omega$ load by a 2-turn 25 mm loop as near as 25 mm to the case of the instrument with the output set to less than $-20$ dBm and the output terminated in a 50 $\Omega$ sealed load.

**Protection:**

N socket; Reverse power overload is indicated by a visual warning (REMOVE RF INPUT) and an audible alarm.

BNC socket; A trip circuit operates at approximately 1.0 W. Reverse power protection up to 50 W, automatically resets on removal of power input. Tripping is indicated by visual warning (REMOVE RF INPUT) and an audible alarm.

**CW on/off key:**

Switches RF output on and off.



## Modulation generator

### Amplitude modulation

CW range:	1.5 to 400 MHz. Usable from 400 kHz to 500 MHz.
Modulation range:	0 to 99%.
Frequency range:	20 Hz to 20 kHz.
Resolution:	1%.
Indication:	2 digits.
Setting:	Keyboard entry; step change variation by increment/decrement keys and rotary control.
Accuracy:	$\pm 7\%$ of setting $\pm 1$ digit at 1 kHz up to 85% AM. $\pm 10\%$ of setting $\pm 1$ digit from 50 Hz to 5 kHz only and 0 to 70% AM only. $\pm 15\%$ of setting $\pm 1$ digit from 50 Hz to 15 kHz and 0 to 85% AM.

### AM external input

Input impedance:	1 M $\Omega$ in parallel with 40 pF approximately.
CW range:	1.5 to 400 MHz.
Modulation depth range:	0 to 99%.
Frequency range:	20 Hz to 20 kHz.
Sensitivity:	50 Hz to 5 kHz, up to 70% AM; 1.5 V p-p for 30% AM $\pm 10\%$ $\pm 1\%$ AM 50 Hz to 15 kHz, up to 85% AM; 1.5 V p-p for 30% AM $\pm 15\%$ $\pm 1\%$ AM.
AM distortion:	<2% distortion at 1 kHz with 30% AM in a 0.3 to 3.4 kHz bandwidth.

### Frequency modulation

CW range:	0.4 to 1000 MHz.
Deviation range:	0 to 25 kHz.
Modulation frequency range:	20 Hz to 20 kHz.
Resolution:	25 Hz (<6.25 kHz deviation). 100 Hz (<25 kHz deviation).
Indication:	4 digits.
Setting:	Keyboard entry. Step change variation by increment/decrement keys and rotary control.
Accuracy:	$\pm 7\%$ $\pm 10$ Hz (at 1 kHz), $\pm 10\%$ (50 Hz to 15 kHz).

**FM external input**

Input impedance:	1 M $\Omega$ in parallel with 40 pF approximately.
CW range:	0.4 to 1000 MHz.
Deviation range:	0 to 30 kHz deviation.
Modulation frequency range:	1 Hz to 50 kHz.
Sensitivity:	1 V p-p for 5 kHz deviation $\pm 10\%$ .
FM distortion:	<1% distortion at 1 kHz with 5 kHz deviation in a 0.3 to 3.4 kHz bandwidth.

**Phase modulation**

CW range:	0.4 to 1000 MHz.
Deviation range:	0 to 10 rad.
Modulation frequency range:	0.3 to 3.4 kHz.
Resolution:	0.025 rad steps <6.3 rad, 0.1 rad steps >6.3 rad.
Indication:	3 digits.
Setting:	Keyboard entry. Step change variation by increment/decrement keys and rotary control.
Accuracy:	$\pm 8\%$ at 1 kHz, $\pm 11\%$ from 0.3 to 3.4 kHz.

 **$\Phi$ M external input**

Input impedance:	1 M $\Omega$ in parallel with 40 pF approximately.
CW range:	0.4 to 1000 MHz.
Deviation range:	0 to 10 rad.
Frequency range:	0.3 to 3.4 kHz.
Sensitivity:	0.5 V p-p for 5 rad at $\pm 12\%$ at 1 kHz.
$\Phi$ M distortion:	<2% at 1 kHz with 5 rads, measured in a 0.3 to 3.4 kHz bandwidth.

**AF generators**

<b>Two tone:</b>	Two tones are available, separately controllable for frequency, shape and level.
<b>Output impedance:</b>	<5 $\Omega$ .

**Frequency**

Range:	50 Hz to 15 kHz. Usable 10 Hz to 20 kHz.
Resolution:	0.1 Hz from 10 Hz to 9.999 kHz. 1 Hz from 9.999 to 20 kHz.
Indication:	5 digits.
Setting:	Keyboard entry. Step change variation by increment/decrement keys and rotary control.
Accuracy:	$\pm 0.01$ Hz from 10 to 100 Hz. $\pm 0.1$ Hz from 100 Hz to 20 kHz.

**Shape:** Sine, square, triangle and saw-tooth.

**Output level (EMF)**

Range:	0.1 mV to 4.095 V RMS (sine and square), 0.1 mV to 4.095 V peak (triangle and saw-tooth).
Accuracy:	$\pm 5\%$ $\pm 1$ step, 50 Hz to 15 kHz.
Setting:	0.1 mV steps (0.1 to 409.0 mV), 1 mV steps (409 mV to 4.095 V).

**Signal purity (sine only)**

Distortion:	<0.5% at 1 kHz, <1% from 50 Hz to 15 kHz.
Residual noise:	<0.1 mV RMS in CCITT psophometric bandwidth.
DC offset:	<10 mV DC.

**RF frequency meter****Frequency**

Range:	1.5 to 1000 MHz.
Resolution:	1 Hz or 10 Hz up to 200 MHz, 10 Hz only from 200 to 1000 MHz.
Accuracy:	As internal standard $\pm 1$ digit.

**Input**

Impedance:	50 $\Omega$ nominal.
VSWR:	N socket; <1.2:1 to 500 MHz, <1.35:1 to 1000 MHz. BNC socket; <2.2:1 to 1000 MHz.

Sensitivity:	N socket; 5 mW, transmitter test mode selected. In one-port duplex mode, sensitivity reduces to 20 mW. BNC socket; 50 mV usable.
Update rate:	100 ms for frequencies up to 200 MHz with 10 Hz resolution selected, 400 ms for frequencies up to 1000 MHz, 10 Hz resolution only.

## RF power meter

### Input

Impedance:	As RF frequency meter.
VSWR:	As RF frequency meter.
Ranges:	N socket; Transmitter test mode 50 mW to 150 W. Usable down to 5 mW. One-port duplex mode 100 mW to 150 W. Usable down to 20 mW. Two-port duplex mode 50 mW to 100 W. Usable down to 5 mW. BNC socket; 0.05 mW to 1.0 W.
Continuous rating:	75 W at 0 to 50°C.
Maximum input:	N socket; Transmitter test mode, 150 W. One-port duplex mode, 150 W. Two-port duplex mode, 100 W. For limited period, typically 2 minutes at 25°C. End of usable working period is indicated by a visual warning (REMOVE RF INPUT) and an audible alarm. BNC socket; 1.2 W. Trip circuit operates at approximately 1.0 W. Overload protection up to 50 W. Tripping is indicated by a visual warning (REMOVE RF INPUT) and an audible alarm.
Frequency range:	1.5 to 1000 MHz.
Resolution:	1% of indicated bar chart range.
Indication:	2 or 3 digits and analogue display.
Setting:	Automatic ranging on scales 0 to 30, 0 to 100, 0 to 300 mW; 0 to 1, 0 to 3, 0 to 10, 0 to 30, 0 to 100, 0 to 300 W.

Accuracy:  $\pm 10\% \pm 1$  digit up to 500 MHz,  
 $\pm 15\% \pm 1$  digit up to 960 MHz,  
 $\pm 20\% \pm 1$  digit up to 1000 MHz.  
 $\pm 1.25$  dB  $\pm 1$  digit  $\geq 5$  mW over the ranges 825  
to 905 MHz from +15 to +25°C.  
(There may be a difference between a trans-  
mitter test mode reading and a duplex test mode  
reading. The difference is normal and within  
the above limits.)

## Modulation meter

### Input

Manual tune: Provides frequency offset indication from  
carrier, 3 digits and decimal point.  
Indicates most significant positive or negative  
error.

Auto tune: Provides measurement and simultaneous dis-  
play of RF frequency, RF power, modulation  
frequency and level.

Sensitivity: N socket; Transmitter test mode  
5 mW (0.5 V).  
One-port duplex mode  
20 mW (1 V).  
BNC socket; 0.05 mW (50 mV).

Acquisition time: <3 s with 10 Hz resolution selected.

AF filters available: Band-pass – 0.3 to 3.4 kHz.  
Low-pass – 0.3 or 15 kHz.

External filter route: Demodulated signal from the rear panel socket  
to the external filter and returned to the AF  
input socket.

### Amplitude modulation

CW range: 1.5 to 400 MHz.

Modulation depth range: 0 to 90% below 100 MHz.  
0 to 80% from 100 to 400 MHz.  
Usable to 100% when manually tuned.  
Automatic ranging (bar chart), 0 to 10, 0 to 30,  
0 to 100% depth.

Modulation frequency range: 50 Hz to 10 kHz. Usable from 10 Hz to 15 kHz.

Resolution: 1% AM.

Indication: 2 digits and analogue display.

Accuracy:	$\pm 5\%$ of reading $\pm 1$ digit at 1 kHz. $\pm 8.5\%$ of reading $\pm 1$ digit from 50 Hz to 10 kHz.
Demodulation distortion:	At 30% AM and 1 kHz modulation frequency, 0.3 to 3.4 kHz bandwidth; <2% at 21 MHz carrier and above, <5% up to 21 MHz carrier.
Residual AM:	<1% for inputs in a 0.3 to 3.4 kHz bandwidth above 10 mW (N socket) or 0.1 mW (BNC socket).

### Frequency modulation

CW range:	1.5 to 1000 MHz.
Deviation range:	0 to 25 kHz. Automatic ranging (bar chart), 0 to 1, 0 to 3, 0 to 10, 0 to 30 kHz.
Modulation frequency range:	50 Hz to 10 kHz. Usable 10 Hz to 15 kHz.
Resolution:	10 Hz up to 2.5 kHz deviation. 1% up to 25 kHz deviation.
Indication:	3 digits and analogue display.
Accuracy:	$\pm 5\%$ $\pm 1$ digit at 1 kHz. $\pm 7.5\%$ $\pm 1$ digit over range 50 Hz to 10 kHz.
Demodulation distortion:	<1.5% distortion at 5 kHz deviation and 1 kHz modulation frequency in a 0.3 to 3.4 kHz bandwidth.
Residual FM:	<30 Hz (typically 15 Hz) RMS up to 500 MHz, <60 Hz (typically 30 Hz) RMS up to 1000 MHz for inputs in a 0.3 to 3.4 kHz bandwidth above 20 mW (N socket) or 0.2 mW (BNC socket).

### Phase modulation

CW range:	1.5 to 1000 MHz.
Deviation range:	0 to 10 rad. Automatic ranging (bar chart), 0 to 1, 0 to 3, 0 to 10 rad.
Modulation frequency range:	0.3 to 3.4 kHz. Phase demodulation obtained using 750 $\mu$ s de-emphasis.
Resolution:	1% or 0.01 rad.
Indication:	3 digits and analogue display.
Accuracy:	$\pm 5\%$ $\pm 1$ digit at 1 kHz, $\pm 7.5\%$ $\pm 1$ digit from 0.3 to 3.4 kHz with respect to 750 $\mu$ s de-emphasis.

## Noise and distortion meter

### SINAD

Frequency:	1 kHz.
Range:	0 to 18 dB, 0 to 50 dB.
Resolution:	0.1 dB.
Indication:	3 digits and analogue display.
Accuracy:	$\pm 1$ dB.
Sensitivity:	50 mV (100 mV for 40 dB SINAD).

### Distortion

Frequency:	1 kHz.
Range:	0 to 10%, 0 to 30% distortion.
Resolution:	0.1% distortion.
Indication:	3 digits and analogue display.
Accuracy:	$\pm 5\%$ of reading $\pm 0.5\%$ distortion.
Sensitivity:	50 mV (100 mV for 1% distortion).

### S/N

Range:	0 to 30 dB, 0 to 100 dB.
Resolution:	0.1 dB.
Indication:	3 digits and analogue display.
Accuracy:	$\pm 1$ dB.
Sensitivity:	50 mV (100 mV for 40 dB S/N).

## AF frequency meter

### General

Range:	20 Hz to 20 kHz.
Resolution:	0.1 Hz or 1 Hz.
Indication:	3, 4 or 5 digits.
Accuracy:	As internal standard $\pm 1$ digit, $\pm 0.1$ Hz or 0.02% (whichever is greater).
Sensitivity:	50 mV.

**AF voltmeter****General**

Input impedance:	1 M $\Omega$ in parallel with 40 pF approximately.
Frequency range:	50 Hz to 20 kHz (or DC). Usable 20 Hz to 50 kHz.
Level range:	0 to 100, 0 to 300 mV; 0 to 1, 0 to 3, 0 to 10, 0 to 30, 0 to 100 V.
Resolution:	1 mV or 1% (dependent on range).
Indication:	3 digits and analogue display.
Accuracy:	$\pm 3\%$ of reading $\pm 3$ mV $\pm 1$ digit.
Frequency response:	Switchable; band-pass 0.3 to 3.4 kHz, low-pass 300 Hz or 50 kHz.

**Internal frequency standard****Oven-controlled crystal oscillator**

Nominal frequency:	10 MHz.
Temperature coefficient:	$< \pm 5$ parts in $10^8$ from 5 to 55°C, $< \pm 5$ parts in $10^9$ from 55 to 70°C.
Aging rate:	$< 2.5$ part in $10^7$ /year, $< 2.5$ part in $10^8$ /month, $< 1$ part in $10^9$ /day, after 2 months continuous use.
Warm-up time:	Output frequency is within 2 parts in $10^7$ of the final frequency within 10 minutes of being switched on.
Short-term stability:	$< \pm 1$ part in $10^{10}$ RMS frequency error over a 1 s period.
Retrace error:	$< 2$ parts in $10^7$ over 24 hours, at constant tem- perature and after 30 minutes warm-up.



## Digital storage oscilloscope

<b>General</b>	Single or repetitive sweep. Available in transmitter test, receiver test and audio test modes (2955A and 2955R) and in transmitter monitor mode (2955R only). Calibrated for AM, FM and $\Phi$ M. For viewing demodulated audio (plus external input option).
Frequency range:	DC to 50 kHz. From 3 Hz on AC.
Voltage range:	10 mV/div to 20 V/div in 1-2-5 sequence.
Accuracy:	$\pm 5\%$ .
FM ranges:	$\pm 30, 15, 6, 1.5$ kHz deviation at $\pm 10\%$ accuracy.
AM ranges:	20, 10, 5%/div at $\pm 10\%$ accuracy.
$\Phi$ M ranges:	$\pm 15, 7.5, 3, 1.5$ rad at $\pm 10\%$ accuracy.
Sweep rates:	100 $\mu$ s/div to 5 s/div in 1-2-5 sequence. Accuracy locked to internal standard.
Trigger:	Repetitive or single shot storage.

## Selcall (sequential tones) encoder and decoder

<b>General</b>	Encodes up to 33 and decodes up to 33 tones in a CCIR, ZVEI, DZVEI, EEA, EIA or user-defined tone sequence.
Tone encoding facilities:	Sends continuous, burst, single step, extend any tone, null, repeat or frequency shift up to $\pm 9\%$ in 1% steps.
Tone decoding facilities:	Displays tone number, frequency and percentage error. Screen indicates null tones (using CRT) and annotates out-of-limit frequencies.
User-defined tones:	Allows definition for encoding or decoding of up to 15 tones. Frequency ranges are 20 Hz to 20 kHz (encode) and 300 Hz to 3.4 kHz (decode) with duration ranges of 10 to 999 ms (encode) and 20 ms to 1.2 s (decode). Up to a maximum of 33 tones can be sent at any one time. The frequencies are retained in a non-volatile memory.
Capability in audio test mode:	The tones encode and decode facility is available using AF generator output and the AF input BNC sockets.

Revertive tones: Available in receiver test mode. Set of tones is sent and the instrument awaits a response from the unit under test.

### Additional features

#### IF output socket

Frequency: 110 kHz nominal.  
 Level: 180 mV minimum.  
 Impedance: 50  $\Omega$ , minimum load 5 k $\Omega$ .  
 Bandwidth: 50 kHz to 350 kHz.

#### Demodulation output socket

Level: 400 mV p-p for  $\pm 1$  kHz deviation  $\pm 10\%$ .  
 Impedance: 10 k $\Omega$  nominal.  
 Bandwidth: 0.3 to 3.4 kHz band-pass, 300 Hz low-pass or 15 kHz low-pass selected by front panel filter switch.

#### Accessory socket:

Pin 2, +12 V, 100 mA maximum.  
 Pin 7, AF output, 1 W into 8  $\Omega$ .  
 Pin 1, pulse output available under GPIB control, approximately 600 ns.  
 Pins 3, 4, 5, 6, accessory control.

#### DTMF encoding and decoding:

Provides DTMF encoding and decoding under a tones menu.

#### Pager testing:

Encoding of POCSAG code CCIR No.1 Rec. 584.  
 Bit rate 400 to 1500 bit/s.  
 Deviation setting 0 to 25 kHz.  
 Allows entry of the following:-  
     Radio identity code (RIC),  
     4 addresses,  
     2 preset numeric messages,  
     4 alphanumeric messages,  
     Insertion of bit errors.

#### DCS encoding:

Digitally coded squelch.  
 Allows entry of the following:-  
     Bit rate 100 to 200 bit/s,  
     Deviation setting 0 to 25 kHz,  
     Polarity normal or inverted,  
     3-digit code.

#### DCS decoding:

Measures bit rate and deviation. All possible codes and polarity are displayed.

<b>External modulation measurement:</b>	Accessed by means of a receiver modulation setup menu. The instrument can be configured to measure the modulation generated by a signal connected to the external modulation input socket. By adjusting the applied signal level, the required modulation level can be set.
<b>Special key functions</b>	
<b>RX=TX FREQ:</b>	Presets the RF signal generator frequency for receiver test mode to that shown in the transmission test mode.
<b>HOLD DISPLAY:</b>	Freezes instrument settings and readings, facilitating high RF power measurements and hard copy printout of transmitter, receiver, duplex or audio test displays.
<b>INCREMENT:</b>	Available in transmitter, receiver, duplex and audio test modes for defining frequency and level increments and decrements of the AF and RF signal generators. The step size can be any setting within the range and resolution of the test set.
<b>STORE and RECALL:</b>	26 non-volatile stores, 01 to 26, are provided. Each is capable of retaining all front panel settings for up to 10 years. An additional store, 00, is provided to retain the last test set-up in the event of a power failure.
<b>ON OFF (with SET MOD, AF GEN LEVEL or RF GEN LEVEL):</b>	Turn relevant functions on and off.
<b>Hold range on bar chart:</b>	Each displayed bar chart can be held (i.e. no autoranging) by the use of the oscilloscope keys.
<b>HELP key:</b>	Provides access to self test, stores lock, RF frequency meter resolution, default settings for SINAD or S/N, external attenuator offset, variable default deviation, 2955 or 2955A emulation, default AF filter, RX/TX modulation type lock, European or USA tones standard selection and user instruction guide for transmitter, receiver, duplex and audio test modes.

**Miscellaneous**

Audible output:	For listening to demodulated output and received audio.
Two tone modulation:	In transmitter test mode, two tones are available under a tones menu. In receiver test mode, external modulation inputs add to the internal modulation.
Transmitter distortion:	In duplex test mode, transmitter distortion measurement is possible.
Transmitter S/N and SINAD:	In transmitter test mode, S/N and SINAD measurement is possible.
Transmitter audio resonance:	Relative modulation level measurements in transmitter test mode are possible. (Units are .)
<b>Remote control:</b>	All functions except the supply switch and analogue controls are remotely programmable through the GPIB interface unit.
<b>GPIB:</b>	Complies with the following subsets as defined in IEEE 488-1978:- SH1, AH1, T5, L4, SR1, RL1, PPO, DC1, DT1, E1.

**Off-air receiver (2955R only)****General**

Frequency range:	100 kHz to 1000 MHz.
Sensitivity:	2 $\mu$ V for 10 dB SINAD in 12 kHz bandwidth from 1 MHz to 1000 MHz for 3.5 kHz deviation.
Linearity response:	Typically $\pm 6$ dB level accuracy at 100 MHz with reference to -60 dBm over the range -87 to -24 dBm (10 $\mu$ V to 14 mV) at the BNC socket or -67 to -4 dBm (100 $\mu$ V to 140 mV) at the N socket.
Maximum input level:	-24 dBm (14 mV)
Image response:	0 dB at $\pm 42.8$ MHz of RF input.

**General****Power requirements**

Rated supply voltage:	105 to 120 V AC $\pm 10\%$ . 210 to 240 V AC $\pm 10\%$ .
Supply frequency range:	45 to 440 Hz.

Maximum consumption:	100 VA.
DC supply voltage:	11 to 32 V DC.
DC supply consumption:	<60 W.
<b>Radio frequency interference:</b>	Conforms with the requirements of EEC Directive 76/889 as to limits of RF interference.  Conforms with VDE (Verband Deutscher Elektrotechniker) requirements Vfg 1046/1984 Class B. (See self-certificate on page xi at the end of this manual.)
<b>Safety:</b>	Complies with IEC 348.
<b>Environmental</b>	
Rated range of use:	0 to 50°C.
Limit range of operation :	0 to 55°C.
<b>Conditions of storage and transport</b>	
Temperature:	-40 to +70°C.
Humidity:	Up to 90% humidity.
Altitude:	Up to 2500 m (pressurized freight at 27 kPa differential (i.e. 3.9 lbf/in <sup>2</sup> ).
<b>Dimensions and weight</b>	
Height:	197 mm (7.75 in).
Width:	389 mm (15.3 in).
Depth:	584 mm (23.0 in).
Weight:	15.5 kg (34 lb).

## ACCESSORIES

Supplied	Part no.
Operating Manual	46881-952B
Programming Manual	46881-953K
AC Supply Lead	43129-003W
DC Supply Lead	43130-119U
Front Cover	41690-411S
Telescopic Antenna, BNC (2955R only)	54421-001N
Optional	
Service Manual	46881-954A
GPIB Manual	46881-365R
Rack Mounting Kit	54127-304C
Lead Assembly, BNC connectors, 1.5 m	43126-012S
Lead Assembly, N connectors, 1.0 m	54311-095C
Lead Assembly, DIN 7-way connectors, 1.0 m	43130-590R
Lead Assembly, DIN 7-way connectors, 3.0 m	43130-591B
Lead Assembly, BNC connectors, 1.0 (double screened for enhanced RFI performance)	43137-052Y
GPIB Adapter, IEEE male to IEC female	46883-408K
GPIB Lead Assembly, IEEE connectors, 1.0 m	43129-189U
GPIB Lead Assembly, IEEE connectors, 1.0 m (double screened for enhanced RFI performance)	46883-962H
Telescopic Antenna, BNC (2955A only)	54421-001N
Viewing Hood Assembly	54150-022P
Extender Card	46883-725U
Transit Case	46662-353Y
Psophometric CCITT Filter	54499-042L
Psophometric C-message Filter	54499-043J
600 $\Omega$ Balanced to Unbalanced Convertor and 20 dB Attenuator	54411-052M
24 Column Printer	54211-001D
Printer Ribbon and Paper Kit	46883-877P
Battery Pack (with charger)	54462-023W
Battery Pack (without charger)	54462-024D
IF Probe 455 kHz	54451-165L
IF Probe 470 kHz	54451-163Y
IF Probe 10.7 MHz	54451-164N
20 dB AF Attenuator	54431-023A
RF Directional Power Head, 1 to 50 MHz	54421-002L
RF Directional Power Head, 25 to 1000 MHz	54421-003J
Wideband Amplifier	54432-012H
150 Hz Bandstop Filter	54491-325H
Impedance Matching Unit	54411-053C
Microphone Interface Unit	54432-013E
Microphone	54412-020Y
Low Intensity Lamp	54413-020T
Dual DIN Connector Assembly	44990-814K

## Chapter 2

# INSTALLATION

	Page
Unpacking and repacking ... ..	2-1
Mounting arrangements ... ..	2-2
Rack mounting ... ..	2-2
Fitting the battery option ... ..	2-2
Safety testing ... ..	2-3
Power supply requirements ... ..	2-3
AC power supply ... ..	2-3
DC power supply ... ..	2-4
AC and DC operation ... ..	2-4
General purpose interface bus ... ..	2-4
GPIB cable connection ... ..	2-4
GPIB connector contacts ... ..	2-5
Accessory socket ... ..	2-5
RF in/out socket ... ..	2-6
 <b>Fig.</b>	
2-1 GPIB interconnections ... ..	2-4
2-2 GPIB connector contacts ... ..	2-5
2-3 ACCESSORY socket contacts (as viewed from the front) ... ..	2-6

## UNPACKING AND REPACKING

Retain the container, packing material and the packing instruction note (if included) in case it is necessary to reship the instrument.

If the instrument is to be returned for servicing, attach a label indicating the service required, type or model number (on rear label), serial number and your return address. Pack the instrument in accordance with the more detailed information which is given in the packing instruction note or as follows:-

- (1) Place the mains lead in a suitable plastic bag and tape it to the instrument's rear panel.
- (2) Place the instrument within its plastic cover.
- (3) Ensure that the padded fitting is in place within the inner carton and slide the instrument in, rear panel first, leaving the front panel exposed at the open end.
- (4) Fit the separate front panel protecting cover over the panel and close and seal the inner carton.
- (5) Place one of the moulded plastic cushions in the bottom of the outer carton and insert the inner carton so that it locates in the cushion recess.
- (6) Place the remaining plastic cushion over the other end of the innercarton and close and seal the outer carton.
- (7) Wrap the container in waterproof paper and secure it with adhesive tape.

- (8) Mark the package FRAGILE to encourage careful handling.

**Note...**

If the original container or materials are not available, use a strong double-wall carton packed with a 7 to 10 cm layer of shock absorbing material around all sides of the instrument to hold it firmly. Protect the front panel controls with a plywood or cardboard load spreader.

## **MOUNTING ARRANGEMENTS**

Excessive temperature may affect the instrument's performance. Therefore, completely remove the plastic cover, if one is supplied over the case, and avoid standing the instrument on or close to other equipment that is hot.

## **RACK MOUNTING**

The instrument can be mounted in a 19 inch rack using the kit which is available as an optional accessory. Fitting instructions are as follows:-

- (1) Removal of the instrument feet can be carried out without removing the bottom cover. Ease the centre bungs from the feet to expose the retaining screws which are held in captive nuts.
- (2) The front panel stowage cover is held in position by two strike plates located at the front of the case side rails. These are attached by self-tapping screws and have to be removed.
- (3) To remove the instrument handle, first pull off the brown plastic caps at the ends of the handle side arms. Next remove the exposed central retaining screws from either side.
- (4) Fit the rack brackets securing with an M5 x 16 pan head screw and washer, as supplied, on either side. These screws fit into the position formerly occupied by the handle retaining screws.

**Note...**

Ensure adequate outlet for the blown air cooling system.

## **FITTING THE BATTERY OPTION**

The external battery pack, available as an optional accessory, is mounted on top of the instrument as follows:-

- (1) Position the battery pack above the instrument and fit the projecting lugs at the rear of the battery pack (tilting as necessary) into the slots in the instrument's rear feet.
- (2) Secure the pack in place by passing the carrying strap around the body of the instrument then pulling the strap through the friction buckle until tight. Hold the remaining strap length in place using the Velcro fastener.



- (3) To release, press the friction bar to unclamp the strap then ease the lugs out of the rear feet.
- (4) Unclip the connector by pressing on its sides to release it from its storage point, and pull out the attached lead from the case. Reclip the connector to the DC SUPPLY socket on the rear panel.

## SAFETY TESTING

Where safety tests on the AC supply input circuit are required, the following procedures can be applied. These comply with BS4743 and IEC Publication 348. To ensure that AC supply input circuit components and wiring (including earthing) are safe under ambient conditions, proceed, in the order given, as follows:-

- (1) Earth lead continuity test from any part of the metal frame to the bared end of the flexible lead for the earth pin of the user's AC supply plug. Preferably a heavy current (about 25 A) should be applied for not more than 5 seconds.

Test limit: not greater than 0.5  $\Omega$ .

- (2) 500 V DC insulation test from the AC supply circuit to earth.

Test limit: not less than 2 M $\Omega$ .

## POWER REQUIREMENTS

The instrument can be operated from AC mains or from an external battery pack.

### AC power supply

For AC operation, the instrument requires 105 to 120 V or 210 to 240 V, 50 to 400 Hz, 100 VA. The required supply fuses (time lag) are 1A for 105 to 120 V or 500 mA for 210 to 240 V. Before switching on, ensure that the rear panel voltage range switch is in its correct position as revealed by the cut-out in the locking plate, and that the correct value fuses are fitted. To change the mains voltage setting, reverse the locking plate after setting the slide switch to its alternative position.

The AC supply cable is fitted at one end with a female plug which mates with the AC connector at the rear of the instrument. When fitting a supply plug ensure that the connections are as follows:-

Earth (ground)	-	Green/Yellow
Neutral	-	Blue
Live (phase)	-	Brown

When attaching the mains lead to a non-soldered plug it is recommended that the tinned ends of the lead are first cut off to avoid the danger of cold flow resulting in intermittent connection.

## DC power supply

For DC operation, a 16 V 7 Ah rechargeable nickel cadmium battery pack is available as an optional accessory. The battery is protected by a time-lag 6.3 A fuse. Remove the battery lead from its stowage and connect to the DC SUPPLY socket on the instrument rear panel. With a fully-charged battery, operating time is in excess of 1 hour.

Alternatively, an external DC supply of between 11 V and 32 V and able to supply approximately 55 W can be used. Connect the battery leads to the rear panel DC SUPPLY socket ensuring that polarities are correct.

## AC and DC operation

When both the DC supply and the AC supply are connected, the instrument automatically selects AC power. If the AC power is then removed, the instrument switches to DC with no interruption of operation. In certain circumstances, the external power supply may not be able to take the sudden change in load and the inbuilt protection (e.g. current feedback limiting) switches off the supply. This can normally be prevented by setting the DC supply to around 20 V. No problems should be experienced with units able to supply 32 V at approximately 4 A.

To protect the +12 V power supply to board AC1, an in-line fuse has been fitted between boards AC1 and AB1. The fuse is 1.6 A time-lag. Access to it is gained after removal of the upper half of the case. The fuse is located adjacent to the grey box of the crystal oscillator.

## GENERAL PURPOSE INTERFACE BUS

### GPIB cable connection

Connection to other equipment which has an IEEE488 24-way connector can be made with the GPIB lead assembly 43129-189U, available as an optional accessory. An IEEE-to-IEC adapter 46883-408K is also available for connecting to systems using a 25-way bus connector to IEC625 as shown in Fig. 2-1 below. Where conformity with the radio frequency interference limits specified by VDE (Verband Deutscher Elektrotechniker) is required, a double-screened lead assembly 46883-962H is available as an optional accessory.

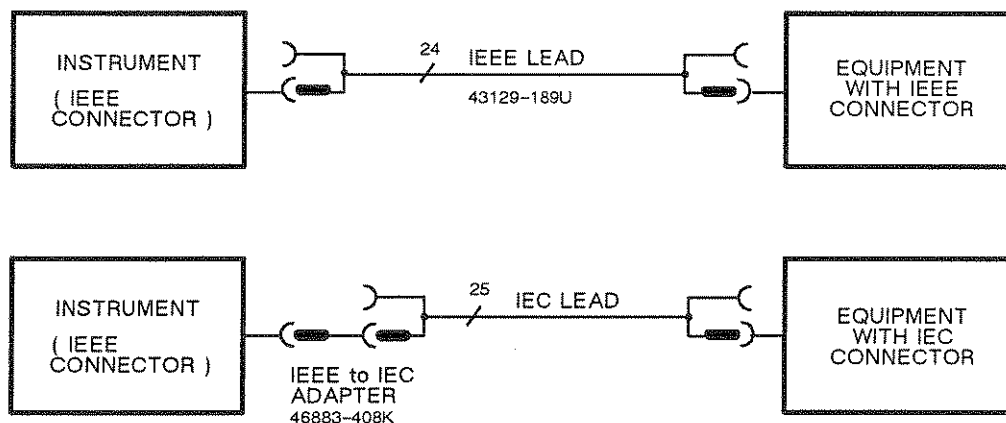

Fig. 2-1 GPIB interconnections

### GPIB connector contacts

The contacts on the GPIB cable connector and the device connector is as shown in Fig. 2-2 below.

The cables have special male-female connectors at both ends. This allows several connectors to be stacked one on top of another permitting several cables to be connected to the same source and secured by a lock screw mechanism. Too large a stack however, may form a cantilevered structure which might cause damage and should be avoided. The piggyback arrangement permits star or linear interconnection between the devices forming a system with the restriction that the total cable length for the system is as follows:-

- (1) No greater than 20 m (65 ft).
- (2) No greater than 2 m (6 ft) times the total number of devices (including the controller) connected to the bus.

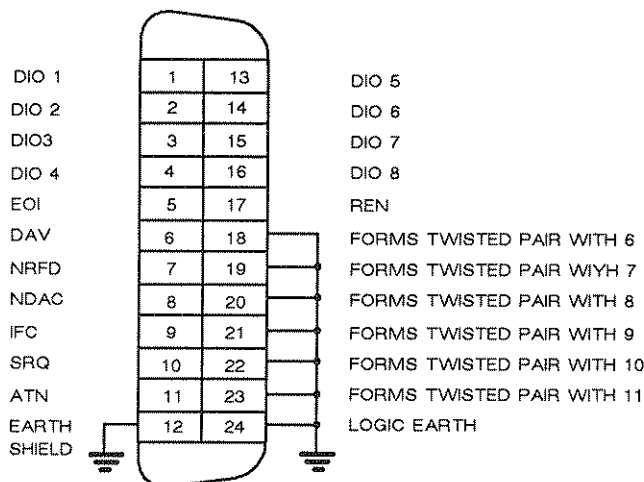

Fig. 2-2 GPIB connector contacts

### ACCESSORY SOCKET

The pin numbering of the 7-way DIN socket is shown in Fig. 2-3 as viewed from the front of the instrument. Reading clockwise from the earth shield locating spigot the functions in position order are:-

Position	Pin	Function
1	6	Logic
2	1	Logic
3	4	Forward power
4	2	+12 V DC at approx 100 mA
5	5	Reverse power
6	3	Logic
7	7	Demodulated output

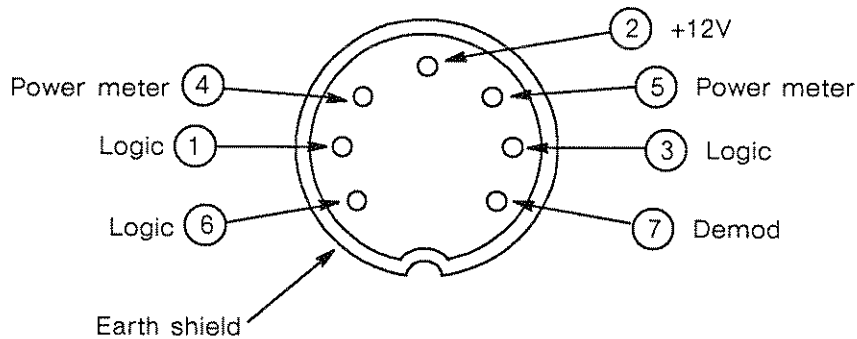

Fig. 2-3 ACCESSORY socket contacts (as viewed from the front)

Selection logic on pins 6, 1 and 3 enable the instrument to detect and recognise the connection of an external accessory. The appropriate pins are at TTL levels and are active low (L) as shown below:

Accessory	Pin 6	Pin 1	Pin 3
Nothing connected	High	High	High
Headset (press to talk)	Low	Low	High
External power: Auto zero	Low	High	Low
External power: Peak power	Low	High	High
External power: CW power	High	High	Low
Psophometric filter: C-message	High	Low	Low
Psophometric filter: CCITT	High	Low	High
Spare	Low	Low	Low

A 3.0 m lead assembly 44990-814K is available as an optional accessory.

## RF IN/OUT SOCKET

Where conformity with the radio frequency interference limits specified by VDE (Verband Deutscher Elektrotechniker) is required, a double-screened lead assembly 43137-052Y is available as an optional accessory.

## Chapter 3-1

# INTRODUCTION TO OPERATION

	Page
General ... ..	3-1
Initial settings ... ..	3-1
Self testing ... ..	3-1
Selecting the measurement mode ... ..	3-2
Front panel ... ..	3-2
Rear panel ... ..	3-4
Accessories ... ..	3-5
600 $\Omega$ Balanced Converter and 20 dB attenuator ... ..	3-5
Directional power heads ... ..	3-5
Printer ... ..	3-5
<b>Fig.</b>	
3-1 Front panel ... ..	3-2
3-2 Rear panel ... ..	3-4

## GENERAL

Following power-up conditions and a summary of the front and rear panel controls and connectors, each of the main functions of the instrument is separately detailed in the following chapters. The main functions are arranged under the headings of 'Transmitter testing' (Chap. 3-2), 'Receiver testing' (Chap. 3-3), 'Duplex testing' (Chap. 3-4), 'Audio equipment testing' (Chap. 3-5) and 'Signalling codes testing' (Chap. 3-6). Additional operating information is provided upon pressing the HELP key, details being given under 'Help key operation' (Chap. 3-7). To familiarize yourself with the instrument, try following the procedures given for 'AF generator operation' in Chap. 3-2 and for 'RF generator operation' in Chap. 3-3.

## INITIAL SETTINGS

When switched on, the instrument automatically enters and displays the following set conditions:-

Condition	Setting
Mode	RECEIVER TEST
RF generator frequency	300 MHz
RF generator level	-100 dBm
Modulation frequency	1 kHz
Modulation level	FM 1.5 Hz or user-defined
Filter	0.3 to 3.4 kHz or user-defined
Connector	N socket

## SELF TESTING

At any time, following a period after switch-on to allow the frequency standard to stabilize (typically 5 minutes), the instrument can be self-tested. This facility is entered using the HELP key. Operating details are given in Chap. 3-7.

## SELECTING THE MEASUREMENT MODE

Once the instrument displays its initial settings, you can select the required measurement, usually in three steps as follows:-

- (1) Select the mode (e.g. Transmitter test, receiver test) – A BLUE key.
- (2) Select the function (e.g. AF generator, set modulation) – A GREEN key.
- (3) Enter data (e.g. frequency, level) – ORANGE and WHITE keys.

Changing from one measurement to another is by simple key operation. For details of the use and operation of the controls for each measurement, see under the relevant heading (e.g. to measure transmitter power, see under 'RF power meter').

When the operation of a control appears to cause an unusual response or a lack of it, the reason can be found by checking through the manual for other references to that control. For example, the AC DC key sometimes does not select DC. Checking through the manual reveals that this key is disabled for both SINAD and distortion measurements. In this case, selecting DIST'N OFF re-enables the key for other measurements.

## FRONT PANEL

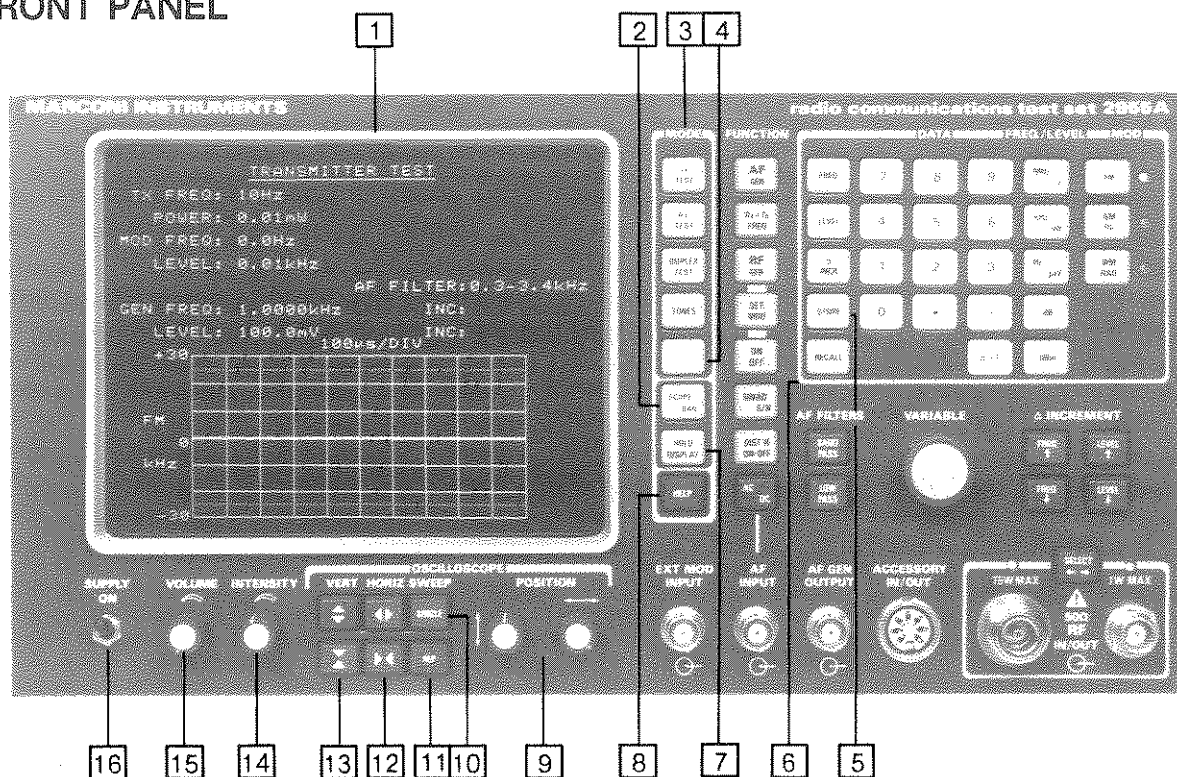

Fig. 3-1 Front panel

- 1 **Display.** This shows one of the following:-
  - (a) Instrument settings and measurement results (in the upper half of the screen) with bar charts or an oscilloscope graticule and trace (in the bottom half of the screen).
  - (b) One of the menus for using the seven blue keys [2], [3], [4] and [7] and the brown key [8] as soft keys to select a programmed function.

Under difficult viewing conditions, the Viewing Hood Assembly 54150-022P, available as an optional accessory, can be used. This folding assembly clips under the screen bezel.

- 2 SCOPE/BAR key.** When SCOPE is selected, the bottom half of the screen shows a single trace on a graticule of 6 x 10 squares. The trace is of the demodulated audio in transmitter testing and of the applied audio in receiver testing. When BAR is selected, the bottom half of the screen shows vertical bar charts, each with an A for autoranging or an H for hold as described under **12** and **11**. Also, this is used as a soft key to select a programmed function from menus which are shown alongside on the screen.
- 3 MODE keys.** These are used to select TRANSMITTER TEST, RECEIVER TEST, DUPLEX or TONES. Also, these are used as soft keys to select programmed functions from menus which are shown alongside on the screen.
- 4** 2955A only: This key is unmarked. It is used only as a soft key to select programmed functions from menus which are shown alongside on the screen.  
 2955R only: **TX MON ON-OFF key.** This is used to select TRANSMITTER MONITOR testing using the off-air receiver. It is also used as a soft key to select programmed functions from menus which are shown alongside on the screen.
- 5 STORE key.** Stores all front panel settings except those of the analogue controls such as intensity, volume, etc. It is followed by a 2-digit number in the range 01 to 26 to identify the stored setting. Store 00 is automatically allocated to the instrument setting at switch-off or loss of mains or battery power.
- 6 RECALL key.** When followed by a 2-digit number, recalls the front panel setting previously stored using **5**. When followed by 00, restores the instrument settings to those set at the time of switch-off etc.
- 7 HOLD DISPLAY key.** Freezes the display including the oscilloscope or bar charts (but not the trace). All the front panel keys except HOLD DISPLAY are inoperable. When the key is pressed again, the hold is released. Also, this is used as a soft key to select a programmed function from menus which are shown alongside on the screen.
- 8 HELP key.** Displays the HELP menu. See under 'Help key operation'. Also, this is used as a soft key to select a programmed function from menus which are shown alongside on the screen.
- 9 POSITION controls.** Used to vary the trace position, both horizontally and vertically.
- 10 SINGLE SWEEP key.** Allows only one sweep of the oscilloscope trace to occur after a trigger and implements the storage oscilloscope facility. Resets the sweep if it is part way through.
- 11 REP SWEEP key.** Repetitively sweeps the oscilloscope trace on auto trigger. Also, for bar charts, this is used for changing between autoranging and holding the range. Select the bar chart by using **12**. Press the key to change between autoranging shown by an A and holding the range shown by an H.

- 12 **HORIZ key.** Changes the oscilloscope horizontal scale time per division. Also, for bar charts, this is used for changing between holding the range and autoranging. Press the key once or more to highlight the appropriate A or H in reverse video. Then press **11** .
- 13 **VERT keys.** In the TRANSMITTER TEST mode, these change the oscilloscope vertical scale in modulation units per division. In the RECEIVER TEST mode, they change the oscilloscope vertical scale in volts per division.
- 14 **INTENSITY control.** Varies the brightness of the display.
- 15 **VOLUME control.** Controls the output of the built-in loudspeaker which is used for monitoring and for alarms.
- 16 **SUPPLY switch.** When it is switched to ON, the instrument enters the RECEIVER TEST mode.

## REAR PANEL

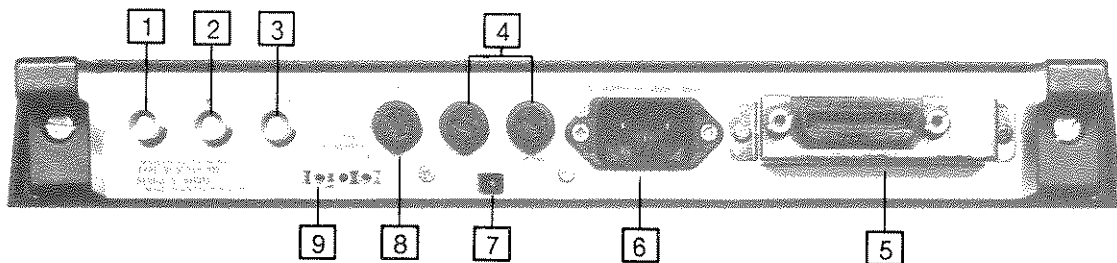

Fig. 3-2 Rear panel

- 1 **IF OUT SOCKET.** BNC socket. Supplies a  $110 \pm 10$  kHz IF output. Do not load with less than 10 k $\Omega$ .
- 2 **DE-MOD OUT socket.** BNC socket. Supplies a demodulated output from the modulation meter. Do not load with less than 10 k $\Omega$ .
- 3 **EXT STD 1 MHz socket.** BNC socket. For the connection of an external 1 MHz standard. Connection automatically phase locks the internal standard to the external signal.
- 4 **AC supply fuses.** Time delay, cartridge type, for fusing **6** . For details, see under 'Power supply requirements' in Chap. 2.
- 5 **GPIB interface unit.** For remote operation of the instrument.
- 6 **AC supply socket.** 3-pin AC supply input connector.
- 7 **Supply voltage selector.** To change the range.
- 8 **DC supply fuse.** Time delay, cartridge type, for fusing **9** . For details, see under 'Power supply requirements' in Chap. 2.
- 9 **DC supply socket.** 3-pin socket for connection to an optional battery unit or to an external battery. For fitting a battery pack and for operating details, see under 'Fitting the battery option' in Chap. 2.



## ACCESSORIES

### 600 $\Omega$ Balanced Converter and 20 dB Attenuator

This is available as an optional accessory. See under 'Accessories' in Chap. 1.

It converts the high impedance of the AF INPUT and the low impedance of the AF GEN OUTPUT into 600  $\Omega$  balanced impedances.

It also provides a low impedance output from the AF GEN OUTPUT which is attenuated by 20 dB.

See the Operating Instructions for the accessory, under 'AF generator operation' in Chap. 3-2 and under 'AF voltmeter operation' in Chap. 3-3.

### Directional Power Heads

These are available as optional accessories. See under 'Accessories' in Chap. 1.

They enable measurement of forward power, reverse power and VSWR in coaxial RF transmission lines and antenna systems. The HF model is for 1 to 50 MHz and the UHF model is for 25 to 1000 MHz.

See The Operating Manual for the accessory and under 'RF power meter operation' in Chap. 3-2.

### Printer

This is available as an optional accessory. See under 'Accessories' in Chap. 1.

See the Instruction Manual for the accessory and Chap. 3-8.

Blank page.

## Chapter 3-2

# TRANSMITTER TESTING

	Page
AF generators ... ..	3-8
AF generator controls and connectors ... ..	3-8
AF generator operation ... ..	3-9
TONES menu ... ..	3-11
Audio setup ... ..	3-11
RF power meter... ..	3-12
RF power meter controls and connectors ... ..	3-12
RF power meter operation ... ..	3-13
Modulation meter ... ..	3-14
Modulation meter controls and connectors ... ..	3-14
Modulation meter operation ... ..	3-15
Distortion meter... ..	3-16
Distortion meter controls and connectors ... ..	3-16
Distortion meter operation ... ..	3-17
Applications ... ..	3-18
Transmitter frequency adjustment ... ..	3-18
 <b>Fig.</b>	
3-3 AF generator controls and connectors ... ..	3-8
3-4 RF power meter controls and connectors ... ..	3-12
3-5 Modulation meter controls and connectors ... ..	3-14
3-6 Distortion meter controls and connectors ... ..	3-16

## AF GENERATORS

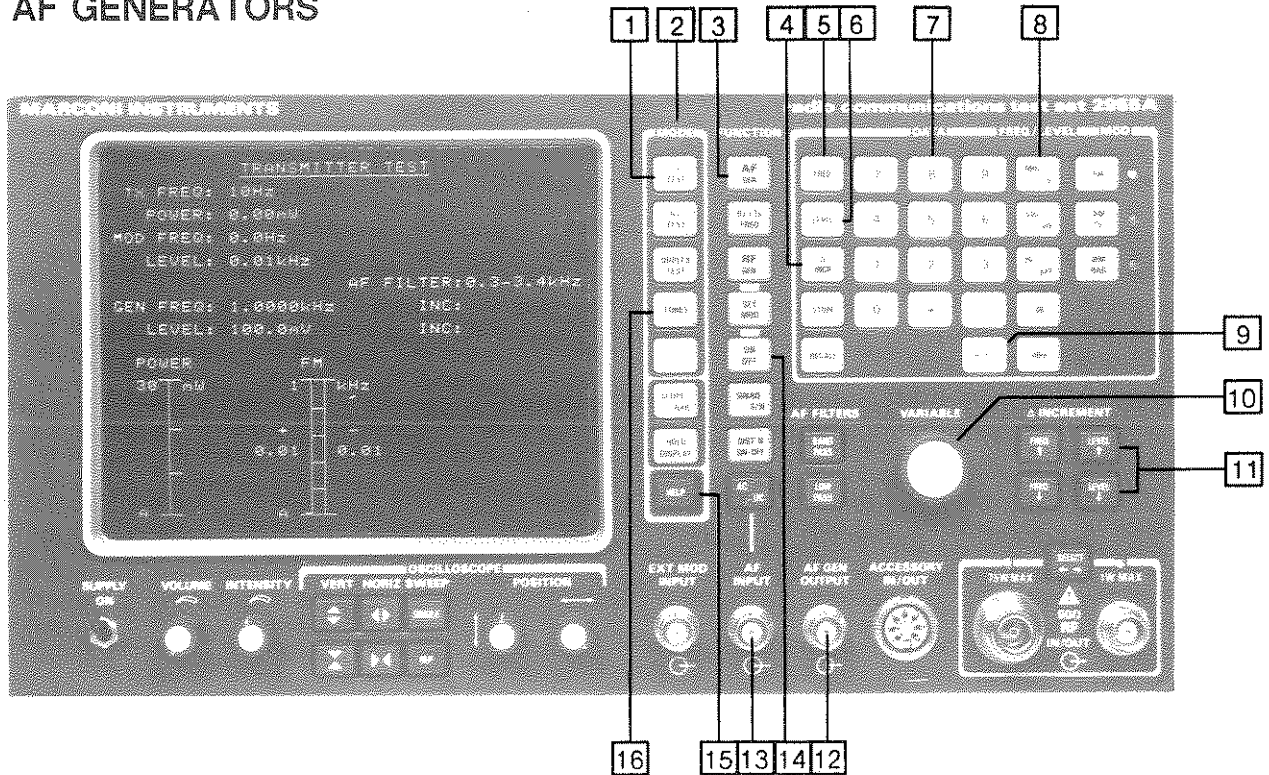

Fig. 3-3 AF generator controls and connectors

### AF generator controls and connectors

- 1 TX TEST key. Used to select the TRANSMITTER TEST mode. Connects the AF generator to the AF GEN OUTPUT socket 12 .
- 2 MODE keys. Used as soft keys to select programmed functions when menus are shown alongside on the screen.
- 3 AF GEN key. Enables the two internal AF generators.
- 4 Δ INCR key. Follows a FREQ 5 or LEVEL 6 entry so that the entered data is recognized as an increment or decrement.
- 5 FREQ key. Precedes a keypad 7 entry so that the entered data is recognized as a frequency.
- 6 LEVEL key. Precedes a keypad 7 entry so that the entered data is recognized as a level.
- 7 DATA keypad. For data entry using numerals 0 to 9, decimal point and minus sign.
- 8 FREQ/LEVEL keys. For defining units of frequency or level. One of these terminates the data entry.
- 9 DELETE key. Deletes a preceding digit, decimal point or minus sign which has been entered on the keypad 7 .

- [10] VARIABLE control.** Analogue control which varies the smallest increment of the function data. Step size is independent of **[4]** and depends upon range. The level or frequency assignment is shown in reverse video on the screen.
- [11]  $\Delta$  INCREMENT keys.** Increase and decrease the frequency and the level by the increments which have been set using **[4]**.
- [12] AF GEN OUTPUT socket.** BNC connector. Supplies one or two outputs in the range 10 Hz to 20 kHz for single-tone or two-tone operation. Impedance  $<5 \Omega$ .
- [13] AF INPUT socket.** BNC socket. For the audio input. Impedance  $1 M\Omega$ .
- [14] ON OFF key.** Enables and disables the AF generators.
- [15] HELP key.** Enables access to the CHANGE PARAMETERS menu for selection of the  $600 \Omega$  Balanced Converter and 20 dB Attenuator.
- [16] TONES key.** Used to select the TONES menu.

### AF generator operation

AF generator operation consists of initial actions (1) to (4) and then, for one or both of the two AF generators, AF frequency setting (5) to (7) and level setting (8) to (11) as follows:-

- (1) Select TX TEST **[1]**. The TRANSMITTER TEST display appears.
- (2) Press AF GEN **[3]**. This selects the first AF generator. AF GEN is shown in reverse video on the screen. To select the second AF generator, press AF GEN **[3]** followed by 2 on the keypad **[7]**. After this, use AF GEN **[3]** followed by 1 on the keypad **[7]** when you require to go back to the first AF generator. For the second AF generator, 2 is shown on the display. For the first AF generator, 1 is shown on the display only when both are enabled. Initially, the first AF generator is enabled and the second is OFF. To enable and disable each AF generator, press the ON OFF key **[14]**.
- (3) Connect the unit under test to the AF GEN OUTPUT socket **[12]**.
- (4) To use the  $600 \Omega$  Balanced Converter, connect it to the AF GEN OUTPUT **[12]** and to the AF INPUT **[13]** sockets. To change the AF voltage readings to dBm (into  $600 \Omega$ ), press the HELP key **[15]**. Then select the CHANGE PARAMETERS option and continue as described under '600  $\Omega$  Balanced Converter selection' in Chap. 3-7. When ON is selected, dBm appears in place of voltage.

- (5) Select FREQ [5]. The frequency to be changed is shown in reverse video. Enter the data on the keypad [7], ending with the frequency terminator [8]. To enter 1.235 kHz, use the following:-



If a mistake is made during data entry, press DELETE [9] and then enter the correct character. When, however, the terminator [8] has been pressed, re-enter the complete data. If incorrect data has been entered (e.g. a frequency outside the range of the instrument), the terminator is ignored and the entry is not be accepted. Use DELETE and then re-enter the data.

- (6) If required, set the frequency increment/decrement by selecting Δ INCR [4] and entering the data, ending with the frequency terminator. To enter 500 Hz steps, use the following:-

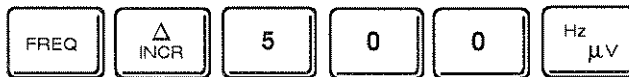

In the example, FREQ can be omitted since it has been previously entered in (5).

- (7) Having set the step size, the frequency can be adjusted by repeatedly pressing one of the Δ INCREMENT keys [11], FREQ ↑ for an increment or FREQ ↓ for a decrement. For fine frequency control, use the VARIABLE control [10].

- (8) Select LEVEL [6]. The level to be changed is displayed in reverse video. Enter the data on the keypad [7], ending with the level terminator [8]. To enter 50 mV, use the following:-



- (9) If required, set the level increment/decrement by selecting Δ INCR [4] and entering the data, ending with the level terminator. To enter 200 mV steps, use the following:-



In the example, LEVEL can be omitted since it has been previously entered in (8).

- (10) Having set the step size, the level can be adjusted by repeatedly pressing one of the Δ INCREMENT keys [11], LEVEL ↑ for an increment or LEVEL ↓ for a decrement. For fine level control, use the VARIABLE control [10].

- (11) To use the 20 dB Attenuator, connect it to the AF GEN OUTPUT socket [12]. To change the level reading, press the HELP key [15]. Then select the CHANGE PARAMETERS option and continue as described under '20 dB Attenuator selection' in Chap. 3-7. When ON is selected, a reverse video A is displayed and the displayed AF generator level is decreased by a factor of 10 (20 dB).

## TONES menu

This gives access to the TX AUDIO SETUP menu as described below in addition to other options which are described in Chap. 3-6.

In the TRANSMITTER TEST mode, press the TONES key **[15]**. The TONES menu appears.

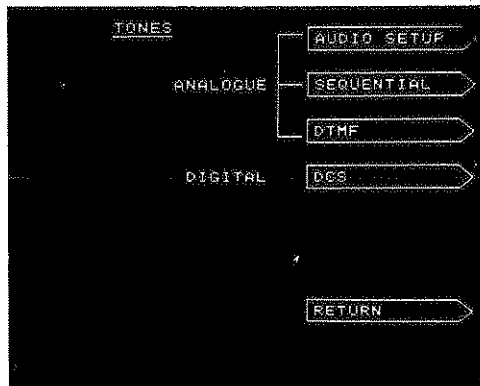

## Audio setup

Under the TONES menu, press the AUDIO SETUP key. The TX AUDIO SETUP menu appears.

This menu is an alternative display under which the AF generator frequencies and levels can be set, both being shown together. In addition, the AF generators can be enabled and disabled, the levels can be locked together and the waveforms can be selected.

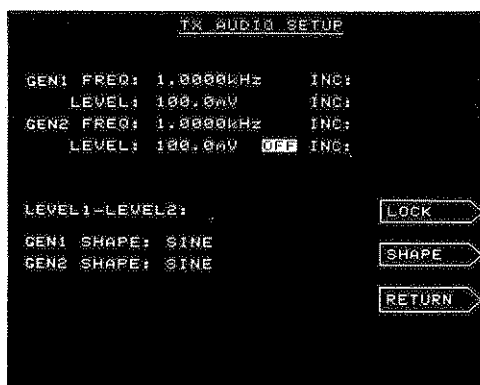

To enable or disable the AF generators, select the generator (as described under 'AF generator operation') and then use the ON OFF key **[14]** to select enabled or OFF. When both AF generators are enabled, 2T (two tone) is shown on the display.

To lock the level of GEN2 so that it is the same as the level of GEN1, press the LOCK key to select LOCKED.

To change a waveform, select the AF generator and then use the SHAPE key to select SINE, SQUARE, TRIANGLE or SAW TOOTH.

Pressing RETURN restores the TRANSMISSION TEST display.

## RF POWER METER

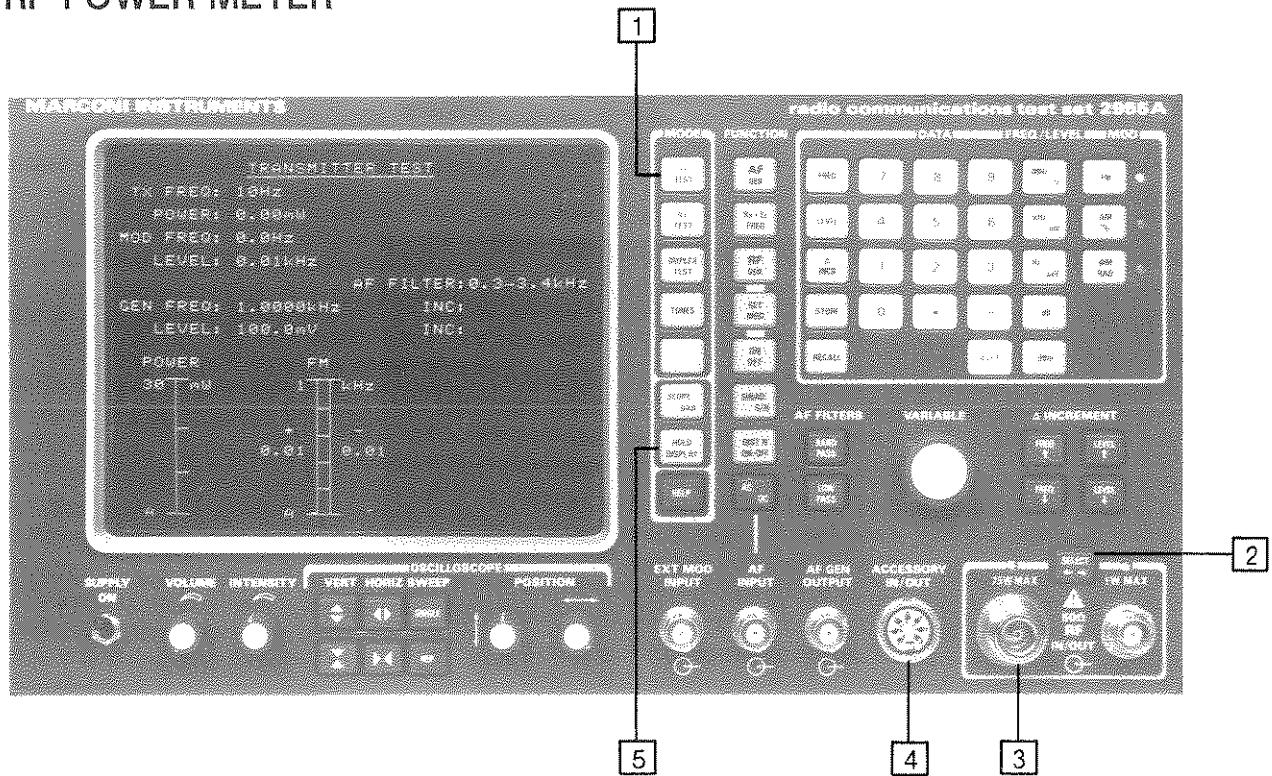

Fig. 3-4 RF power meter controls and connectors

### RF power meter controls and connectors

- 1 **TX TEST key.** Connects the RF power meter and the RF counter to the RF IN/OUT N socket 3 . Writes on the screen information concerning the instrument settings.
- 2 **SELECT key and LEDs.** For selecting RF IN/OUT N socket 3 . LED lights above the socket when it is correctly selected.
- 3 **RF IN/OUT N socket.** For the transmitter output. A temperature sensor detects excessive power being applied. Impedance 50  $\Omega$ .
- 4 **ACCESSORY socket.** DIN 7-pin connector for the external RF directional power head option.
- 5 **HOLD DISPLAY key.** The display, including the oscilloscope or bar charts (but not the trace), is frozen. All keys, except HOLD DISPLAY, are inoperable. When the key is pressed again, the hold is released.



## RF power meter operation

Proceed as follows:-

- (1) Select TX TEST  1 . This connects the RF power meter and the RF counter to the RF IN/OUT N socket  3 . Writes TRANSMITTER TEST on the screen.
- (2) Press SELECT  2 , if necessary, to light the LED above the RF IN/OUT N socket  3 .
- (3) Connect the unit under test to the RF IN/OUT N socket  3 .
- (4) The instrument automatically tunes to the transmitter's RF frequency.
- (5) If the applied power exceeds that allowable, the display flashes REMOVE RF INPUT followed shortly by an audible warning.
- (6) The applied RF power and carrier frequency are displayed on the screen.
- (7) If required, the transmitter can be tuned for minimum or zero indicated offset using the 2955A. See 'Transmitter frequency adjustment' at the end of this chapter.
- (8) If required, connect the RF Directional Power Head to the ACCESSORY socket  4 for automatic measurement and display of forward and reverse power and of VSWR.

## MODULATION METER

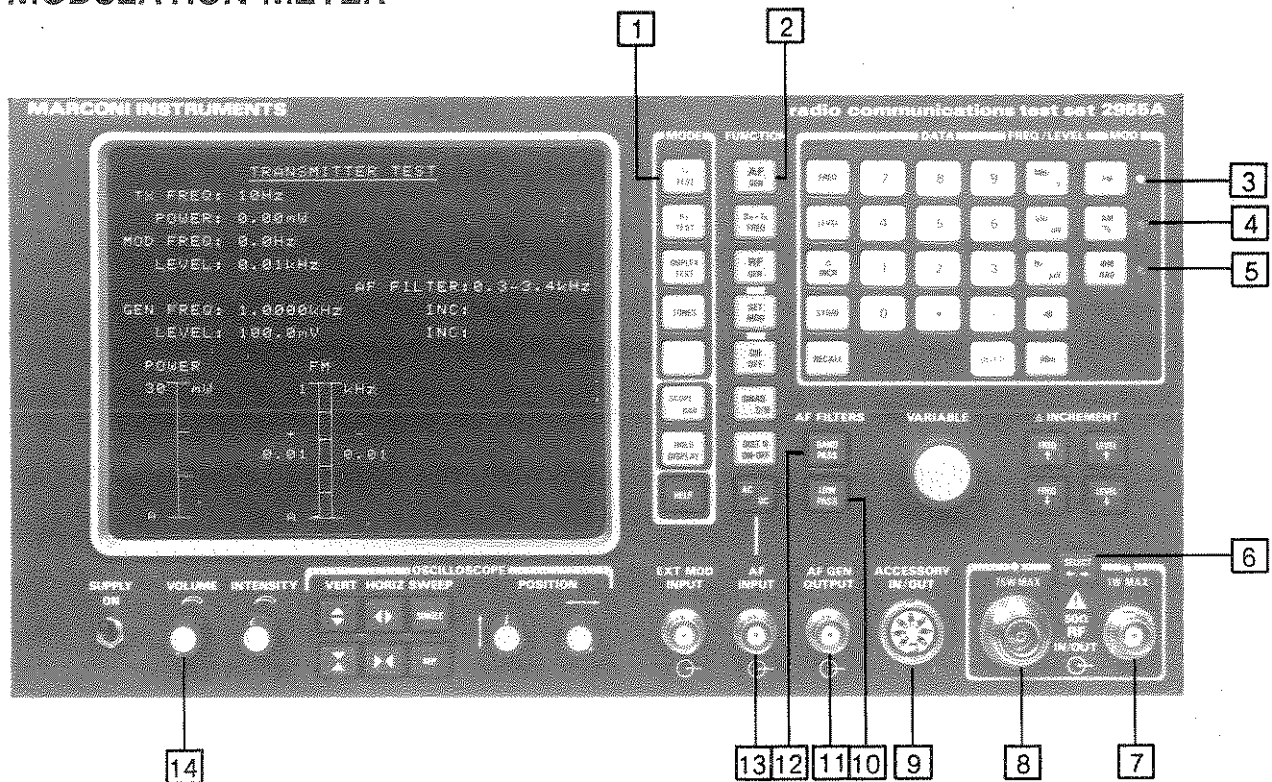

Fig. 3-5 Modulation meter controls and connectors

### Modulation meter controls and connectors

- 1 **TX TEST key.** Connects the modulation meter to RF IN/OUT socket 7 or 8 and connects the AF generator to the AF GEN OUTPUT socket 11. Writes on the screen information concerning instrument settings.
- 2 **AF GEN key.** Enables the internal AF generator to supply a modulating signal to socket 11.
- 3 **MOD FM key and LED.** When the key is pressed, the LED lights to show that FM modulation has been selected.
- 4 **MOD AM key and LED.** When the key is pressed, the LED lights to show that AM modulation has been selected.
- 5 **MOD  $\Phi$ M key and LED.** When the key is pressed, the LED lights to show that  $\Phi$ M (FM with de-emphasis) demodulation has been selected.
- 6 **SELECT key and LEDs.** For selecting RF IN/OUT BNC or N socket 7 or 8. LED lights above the socket selected.
- 7 **RF IN/OUT BNC socket.** For the Telescopic Antenna which is available as an optional accessory. Automatically protected against excessive power.
- 8 **RF IN/OUT N socket.** For high level inputs. A temperature sensor detects excessive power being applied. Impedance 50  $\Omega$ .

- [9] ACCESSORY socket.** DIN 7-pin connector for external loudspeaker or earphones. Connection does not disable the internal loudspeaker. Control of volume is by **[14]**.
- [10] LOW PASS key.** Selects a 300 Hz or a 15 kHz low-pass filter.
- [11] AF GEN OUTPUT socket.** BNC connector. Supplies a modulating output in the range 10 Hz to 20 kHz. Impedance  $<5 \Omega$ .
- [12] BAND PASS key.** Selects a 0.3 to 3.4 kHz band-pass filter or an external filter.
- [13] AF INPUT socket.** BNC connector. For input from an external filter.
- [14] VOLUME control.** Controls the volume of the internal loudspeaker and of a loudspeaker or earphones connected to **[9]**.

### Modulation meter operation

To measure AM depth or FM and  $\Phi$ M deviation, proceed as follows:-

- (1) Select TX TEST **[1]**. The TRANSMITTER TEST display appears.
- (2) Connect the transmitter output to the RF IN/OUT N socket **[8]**. Alternatively, connect the Telescopic Antenna (available as an optional accessory) to the RF IN/OUT BNC socket **[7]**.
- (3) The instrument automatically tunes to the transmitter's frequency. If required, the transmitter can be tuned for minimum or zero indicated offset using the 2955A. See 'Transmitter frequency adjustment' at the end of this chapter.
- (4) Press SELECT **[6]** until the LED lights above the RF IN/OUT N connector **[8]** or the BNC socket **[7]**.
- (5) Select modulation type FM **[3]**, AM **[4]**, or  $\Phi$ M **[5]**. If greater than 50% AM is applied, there is a possibility that false readings may occur. Use keyboard tuning of the modulation meter as for 'Transmitter frequency adjustment' at the end of this chapter.
- (6) Press BAND PASS **[12]** once or twice as necessary to select the 0.3 to 3.4 kHz BP filter or an EXTERNAL filter or press LOW PASS **[10]** once or twice as necessary to select a 300 Hz or 15 kHz LP filter. The external filter is connected between the DE-MOD OUT socket (on the rear) and the AF INPUT socket **[13]**.
- (7) If required, modulate the transmitter's carrier by connecting the AF GEN OUTPUT socket **[11]** to the microphone input of the transmitter. Set the frequency and level as under 'AF generator operation'.
- (8) Read the displayed % depth for AM or the deviation and symmetry for FM and  $\Phi$ M.
- (9) Adjust VOLUME control **[14]** to monitor the demodulated signal using the internal loudspeaker, an external loudspeaker or earphones using the ACCESSORY socket **[9]**.
- (10) The demodulated output is available at the DE-MOD OUT socket on the rear panel.

DISTORTION METER

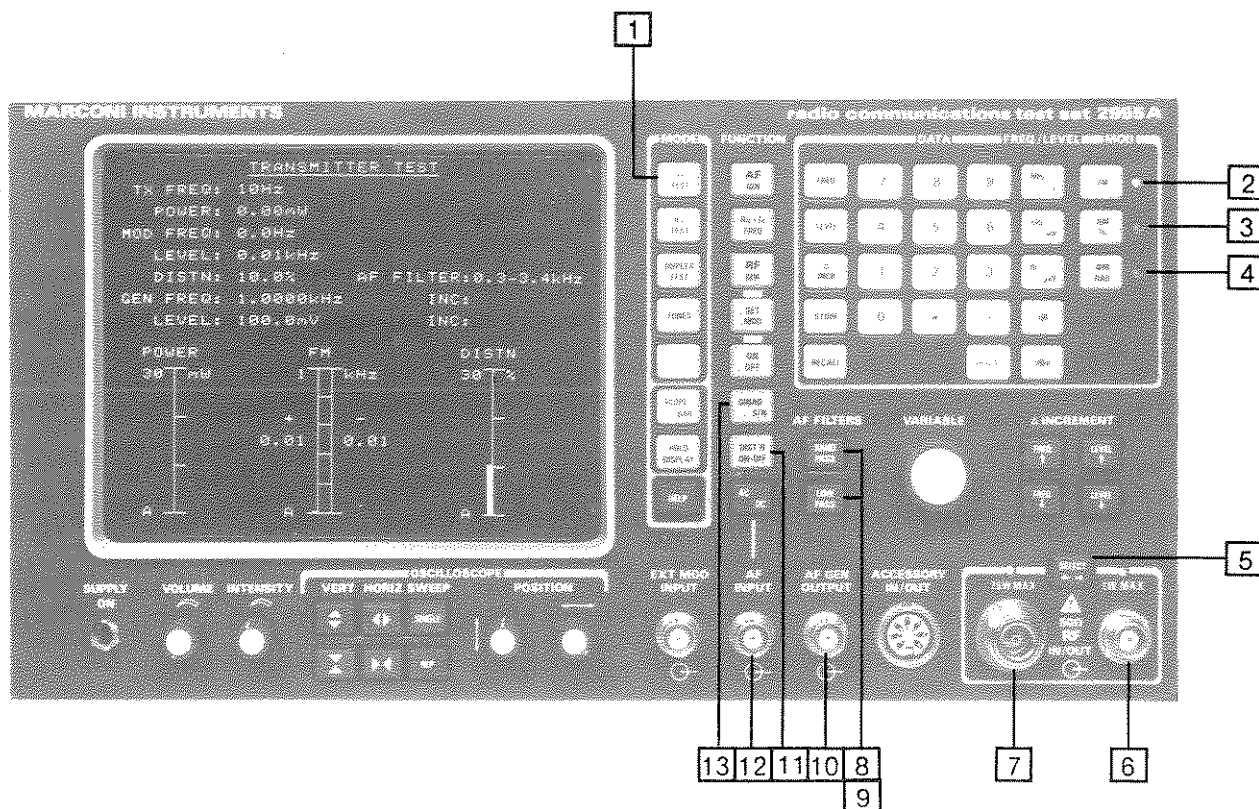

Fig. 3-6 Distortion meter controls and connectors

Distortion meter controls and connectors

- 1 TX TEST key. Connects the distortion meter to the RF IN/OUT BNC socket 6 or N socket 7 and connects the AF generator to the AF GEN OUTPUT socket 8. Writes on the screen information concerning instrument settings.
- 2 MOD FM key and LED. When the key is pressed, the LED lights to show that the FM route to the demodulator has been selected.
- 3 MOD AM key and LED. When the key is pressed, the LED lights to show that the AM route to the demodulator has been selected.
- 4 MOD ΦM key and LED. When the key is pressed, the LED lights to show that the ΦM route (FM route with the de-emphasis) has been selected to the demodulator.
- 5 SELECT key and LEDs. For selecting RF IN/OUT socket 6 or 7. LED lights above the socket selected.
- 6 RF IN/OUT BNC socket. For the transmitter input. Automatically protected against excessive power. Impedance 50 Ω.
- 7 RF IN/OUT N socket. For the transmitter input. A temperature sensor detects excessive power being applied.
- 8 BAND PASS key. Selects a 0.3 to 3.4 kHz band-pass filter or an external filter.

- 9 **LOW PASS key.** Selects a 300 Hz or a 15 kHz low-pass filter.
- 10 **AF GEN OUTPUT socket.** Output used to modulate the transmitter under test with a 1 kHz tone. Impedance  $<5 \Omega$ .
- 11 **DIST'N ON-OFF key.** Causes the AF generator to generate a 1 kHz tone to socket 10. The display indicates when distortion is selected.
- 12 **AF INPUT socket.** BNC connector. For input from an external filter.
- 13 **SINAD S/N key.** Selects SINAD or signal/noise. When SINAD is selected, causes the AF generator to generate a 1 kHz tone to socket 10. The display indicates when SINAD or S/N is selected.

### Distortion meter operation

To make a transmitter distortion measurement, proceed as follows:-

- (1) Select TX TEST 1. The TRANSMITTER TEST display appears.
- (2) Connect the transmitter output to the RF IN/OUT BNC connector 6 for a low level RF output or to the RF IN/OUT N connector 7 for a high level RF output.
- (3) Press SELECT 5 and ensure that the LED lights above the socket selected.
- (4) The instrument automatically tunes to the transmitter's frequency. If required, the transmitter can be tuned for minimum or zero indicated offset using the 2955A. See 'Transmitter frequency adjustment' at the end of this chapter.
- (5) Connect the AF GEN OUTPUT socket 10 to the transmitter's microphone input to provide amplitude, frequency or phase modulation.
- (6) Press DIST'N ON-OFF 11 until DISTN is displayed. This causes a 1 kHz tone to be generated to socket 10 to modulate the transmitter.
- (7) Select modulation FM 2, AM 3, or  $\Phi$ M 4.
- (8) The 0.3 to 3.4 kHz BP filter is automatically selected. Press LOW PASS 9 once or twice as necessary to select a 300 Hz or 15 kHz LP filter. Press BAND PASS 8 once or twice as necessary to return to the 0.3 to 3.4 kHz BP filter or to an EXTERNAL filter. The external filter is connected between the DEMOD OUT socket (on the rear) and the AF INPUT socket 12.
- (9) Read the % distortion from the display.
- (10) Press the SINAD S/N key 13 until SINAD is displayed.
- (11) Read the SINAD in dB from the display.
- (12) Press the SINAD S/N key 13 until S/N is displayed.

- (13) Read the S/N from the display.
- (14) To return to normal operation, select DIST'N OFF using key 11 .

## APPLICATIONS

### Transmitter frequency adjustment

If the transmitter setting (e.g. 400 MHz), does not agree with the measured frequency (e.g. 400.000100 MHz), the offset can be corrected as follows:-

- (1) With the TRANSMITTER TEST mode selected, press **FREQ** and then enter the transmitter setting (e.g. 400 MHz).
- (2) The offset is displayed as a positive or negative value (e.g. +100 Hz).
- (3) Adjust the transmitter's internal frequency while observing the offset. Tune until negative values are seen and then readjust positively for zero offset.
- (4) **AUTO TUNE** appears on the screen alongside the **TX TEST** key. Press this key. The 2955A automatically tunes to and displays the transmitter's corrected frequency.

## Chapter 3-3

# RECEIVER TESTING

	Page
RF generator ... ..	3-20
RF generator controls and connectors ... ..	3-20
RF generator operation ... ..	3-22
TONES menu ... ..	3-25
Modulation setup ... ..	3-25
AF voltmeter ... ..	3-27
AF voltmeter controls and connectors ... ..	3-27
AF voltmeter operation ... ..	3-28
Distortion meter ... ..	3-29
Distortion meter controls and connectors ... ..	3-29
Distortion meter operation ... ..	3-30
Fig.	
3-7 RF generator controls and connectors ... ..	3-20
3-8 AF voltmeter controls and connectors ... ..	3-27
3-9 Distortion meter controls and connectors ... ..	3-29

## RF GENERATOR

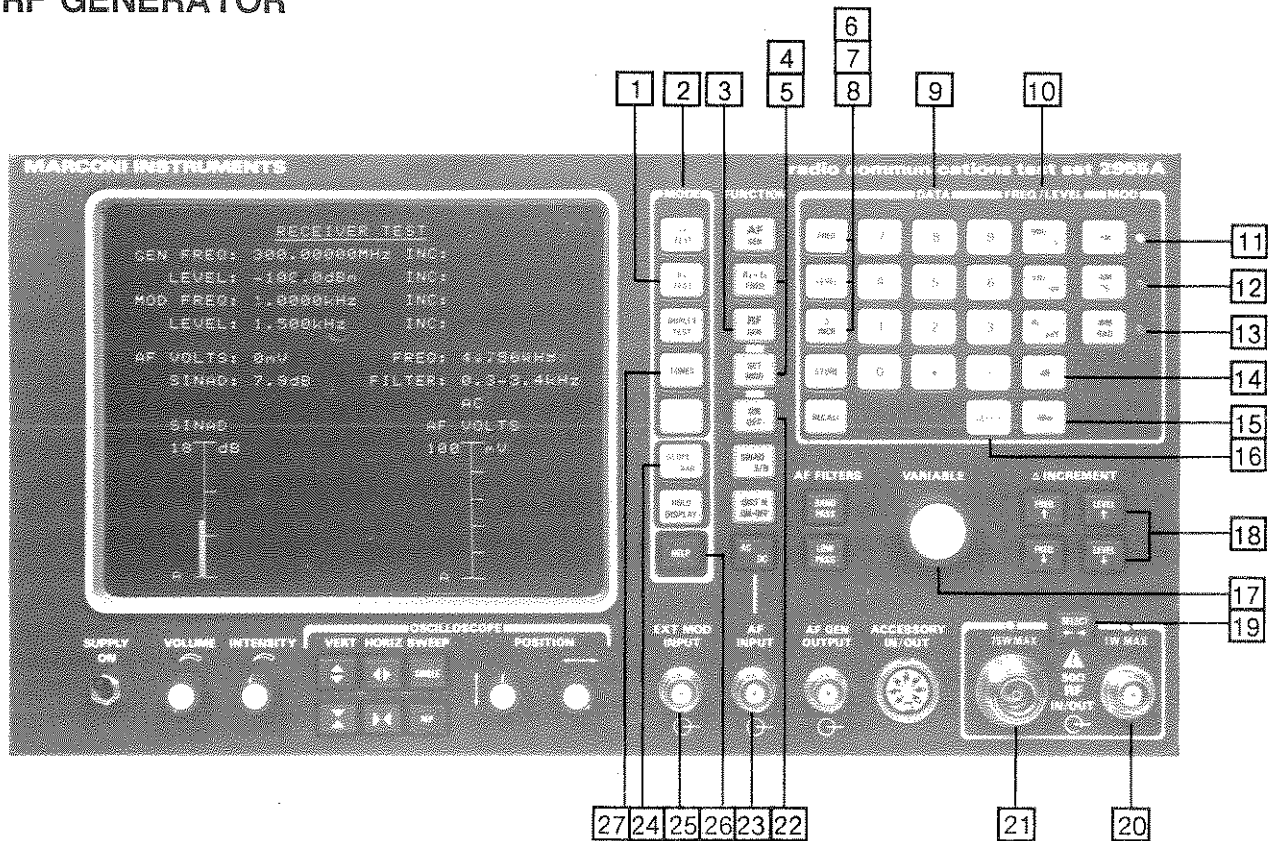

Fig. 3-7 RF generator controls and connectors

## RF generator controls and connectors

- 1 **RX TEST key.** Used to select the RECEIVER TEST mode. Connects the RF generator to the RF IN/OUT BNC and N sockets 20 and 21.
- 2 **MODE keys.** Used as soft keys to select programmed functions when menus are shown alongside on the screen.
- 3 **RF GEN key.** Enables the internal RF generator.
- 4 **RX=TX FREQ key.** Used only when in the TRANSMITTER TEST mode with the transmitter keyed up. Tunes the RF generator to the frequency of a transmitter connected to 20 or 21. The receiver section of a transceiver can be tested without having to enter the frequency.
- 5 **SET MOD key.** Enables the internal RF generator modulation system. Followed by a FREQ 6 or LEVEL 7 entry to set the modulation value.
- 6 **FREQ key.** Precedes a keypad 9 entry so that the entered data is recognized as a frequency.
- 7 **LEVEL key.** Precedes a keypad 9 entry so that the entered data is recognized as a level. As supplied, each 2955A is programmed either for European or for North American standards. European practice is to show the output level as PD or EMF.



- [8] Δ INCR key.** Precedes a keypad **[9]** entry so that the entered data is recognized as an increment or decrement.
- [9] DATA keypad.** For data entry using numerals 0 to 9, decimal point and minus sign.
- [10] FREQ/LEVEL keys.** For defining units of frequency or level. Unless entering modulation, terminates the data entry.
- [11] MOD FM key and LED.** Enables the preceding frequency entry to be recognized as a frequency modulation deviation. Activates the frequency modulator for the RF generator. LED lights to show that FM has been selected. Modulation is switched on and off by **[22]** .
- [12] MOD AM % key and LED.** Enables the preceding keypad **[9]** entry to be recognized as an amplitude modulation percentage. Activates the amplitude modulator for the RF generator. LED lights to show that AM has been selected. Modulation is switched on and off by **[22]** .
- [13] MOD ΦM RAD key and LED.** Enables the preceding keypad **[9]** entry to be recognized as a phase modulation deviation. Activates the frequency modulator with pre-emphasis for the RF generator. LED lights to show that ΦM has been selected. Modulation is switched on and off by **[22]** .
- [14] dB key.** For defining the RF level as dBμV.
- [15] dBm key.** For defining the RF level as dBm.
- [16] DELETE key.** Deletes a preceding digit, decimal point or minus sign which has been entered on the keypad **[9]** .
- [17] VARIABLE control.** Analogue control which varies the smallest increment of the function data. Step size is independent of **[8]** and depends upon range. The level for frequency assignment is shown in reverse video on the screen.
- [18] Δ INCREMENT keys.** Increase and decrease the frequency and the level by the increments which have been set using **[8]** .
- [19] SELECT key and LEDs.** For selecting RF IN/OUT socket **[20]** or **[21]** . LED lights above the socket selected.
- [20] RF IN/OUT BNC socket.** For RF generator output levels up to 225 mV. Impedance 50 Ω. Automatically protected against excessive reverse power during duplex operation.
- [21] RF IN/OUT N socket.** For RF generator output levels up to 22.5 mV. Impedance 50 Ω.
- [22] ON OFF key.** Enables and disables the RF output when **[3]** has been selected. Enables and disables the modulation, both internal and external, when **[5]** has been selected. OFF appears in reverse video when the RF output or the modulation is disabled. Does not affect LEDs **[11]** to **[13]** .

- [23] **AF INPUT socket.** BNC socket. For the audio input. Impedance 1 MΩ.
- [24] **SCOPE/BAR key.** To select the oscilloscope or the bar chart to measure the audio input.
- [25] **EXT MOD INPUT socket.** BNC socket. For the application of an external modulating signal. To set the level of and to enable and disable the external modulation, see later under 'Modulation setup'.
- [26] **HELP key.** Enables access to the CHANGE PARAMETERS menu for selection of EMF (unloaded) or PD (loaded).
- [27] **TONES key.** Used to select the TONES menu.

### RF generator operation

RF generator operation consists of initial action (1) to (3), RF frequency setting (4) to (6), level setting (7) to (9) and modulation setting (10) to (12) followed by (13) to (15) for AM, (16) to (18) for  $\Phi$ M, (19) to (21) for FM and then (22). (23) and (24) are for external modulation. Proceed as follows:-

- (1) Select RX TEST [1] . The RECEIVER TEST display appears.
- (2) Select function RF GEN [3] .
- (3) Connect the unit under test to RF IN/OUT BNC socket [20] or to N socket [21] . Press SELECT [19] until the LED lights above the socket selected for the RF output.
- (4) Select FREQ [6] . The frequency to be changed is shown in reverse video. Enter the data on the keypad [9] , ending with the frequency terminator [10] or [14] (for dB $\mu$ V) or [15] (for dBm). To enter, 123.5 MHz, use the following:-



If a mistake is made during data entry, press DELETE [16] and then enter the correct character. When, however, the terminator [10] has been pressed, re-enter the complete data. If incorrect data has been entered (e.g. a frequency outside the range of the instrument), the terminator is ignored and the entry is not be accepted. Use DELETE and then re-enter the data.

- (5) If required, set the frequency increment/decrement by selecting  $\Delta$  INCR [8] and enter the data, ending with the frequency terminator. To enter 500 kHz steps, use the following:-



In the example, FREQ can be omitted since it has been previously entered in (4).

- (6) Having set the step size, the frequency can be adjusted by repeatedly pressing one of the  $\Delta$  INCREMENT keys [18],  $\text{FREQ} \uparrow$  for an increment or  $\text{FREQ} \downarrow$  for a decrement. For fine frequency control, use the VARIABLE control [17].
- (7) Select LEVEL [7]. The level to be changed is displayed in reverse video. Enter the data on the keypad [9], ending with the level terminator [10]. To change between PD (loaded) and EMF (unloaded), press the HELP key [26] and then continue as described under 'RF level selection' in Chap. 3-7. Switch the RF generator on or off as required using the ON OFF key [22]. To enter -34 dBm, use the following:-

LEVEL [ - ] [ 3 ] [ 4 ] [ dBm ]

- (8) If required, set the level increment/decrement by selecting  $\Delta$  INCR [8] and enter the data, ending with the level terminator. To enter 0.5 dB steps, use the following:-

LEVEL [  $\Delta$  INCR ] [ . ] [ 5 ] [ dB ]

In the example, LEVEL can be omitted since it has been previously entered in (7).

- (9) Having set the step size, the level can be adjusted by repeatedly pressing one of the  $\Delta$  INCREMENT keys [18],  $\text{FREQ} \uparrow$  for an increment or  $\text{FREQ} \downarrow$  for a decrement. For fine level control, use the VARIABLE control [17].
- (10) Press SET MOD [5]. This selects the first modulation generator. MOD is shown in reverse video on the screen. To select the second modulation generator, press SET MOD [5] followed by 2 on the keypad [9]. After this, use SET MOD [5] followed by 1 on the keypad [9] when you require to go back to the first modulation generator. For the second modulation generator, 2 is shown on the display. For the first modulation generator, 1 is shown on the display only when both are enabled. Initially, the first modulation generator is enabled and the second is OFF. To enable and disable each modulation generator, press the ON OFF key [22].
- (11) Select FREQ [6] and then enter the data, ending with the frequency terminator [10]. To enter 1.5 kHz AM, FM or  $\Phi$ M, use the following:-

FREQ [ 1 ] [ . ] [ 5 ] [ kHz mV ]

- (12) If required, the modulation frequency can be adjusted as for (5) and (6).

- (13) For amplitude modulation, select LEVEL  and then enter the modulation depth in %. Terminate with key  and check that the associated lamp lights. To enter 60% AM, use the following:-



- (14) If required, set the modulation value increment/decrement by selecting  $\Delta$  INCR  and entering the step size. To enter a 2% step, use the following:-



In the example, LEVEL can be omitted since it has been previously entered in (13).

- (15) Adjust the modulation value as for (9).

- (16) For phase modulation, select LEVEL  and then enter the deviation in radians. Terminate with key  and check that the associated lamp lights. To enter 6 radians, use the following:-

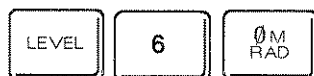

- (17) If required, set the modulation value increment/decrement by selecting  $\Delta$  INCR  and entering the step size. To enter a 2 radians step, use the following:-



In the example, LEVEL can be omitted since it had been entered in (16).

- (18) Adjust the modulation value as for (9).

- (19) For frequency modulation, select LEVEL  and then enter the deviation, ending with the frequency terminator . Press FM  and check that the associated lamp lights. To enter 5 kHz FM deviation, use the following:-

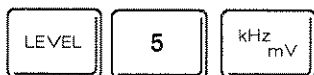

- (20) If required, set the modulation value increment/decrement by selecting  $\Delta$  INCR  and entering the step size. To enter, a 4 kHz step, use the following:-



In the example, LEVEL can be omitted since it has been previously entered in (19).

- (21) Adjust the modulation value as for (9).
- (22) Switch the modulation (both internal and external, if applied) on or off as required using the ON OFF key **[22]** . The off condition is shown in reverse video on the display.
- (23) For external modulation, connect the signal to the EXT MOD INPUT socket **[25]** .

## TONES menu

This gives access to the RX MODULATION SETUP menu as described below in addition to other options which are described in Chap. 3-6.

In the RECEIVER TEST mode, press the TONES key **[27]** . The TONES menu appears.

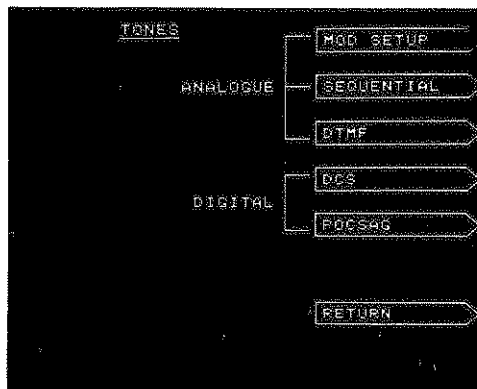

## Modulation setup

Under the TONES menu, press the MOD SETUP key. The RX MODULATION SETUP menu appears.

This menu is an alternative display under which the modulation generator frequencies and levels can be set, both being shown together. In addition, the modulation generators can be enabled and disabled, the levels can be locked together and the waveforms can be selected.

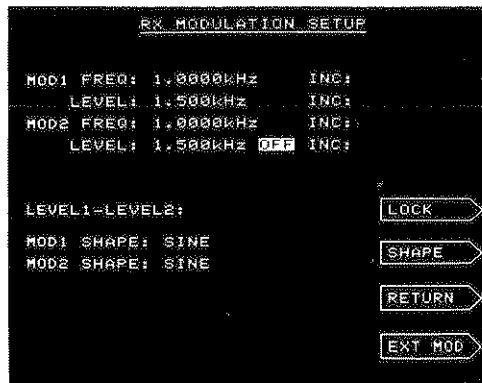

To enable or disable the modulation generators, select the generator (as described under 'RF generator operation') and then use the ON OFF key 14 to select enabled or OFF. When both modulation generators are enabled, 2T (two tone) is shown on the display.

To lock the level of MOD2 so that it is the same as the level of MOD1, press the LOCK key to select LOCKED.

To change a waveform, select the modulation generator and then use the SHAPE key to select SINE, SQUARE, TRIANGLE or SAW TOOTH.

To control the external modulation, press the EXT MOD key. The EXTERNAL MOD INPUT frequency and level appear. These can be set as for the internal modulation. To enable and disable the external modulation, use the key which is arrowed by ON and OFF alternately.

Pressing RETURN restores the RECEIVER TEST display.

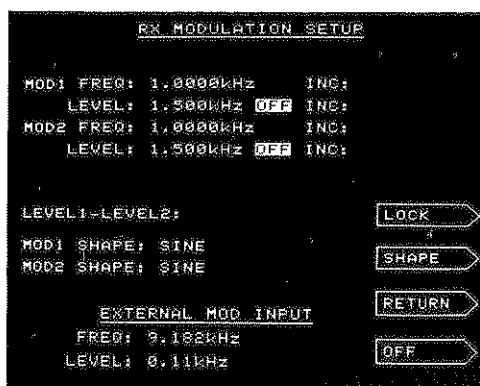

## AF VOLTMETER

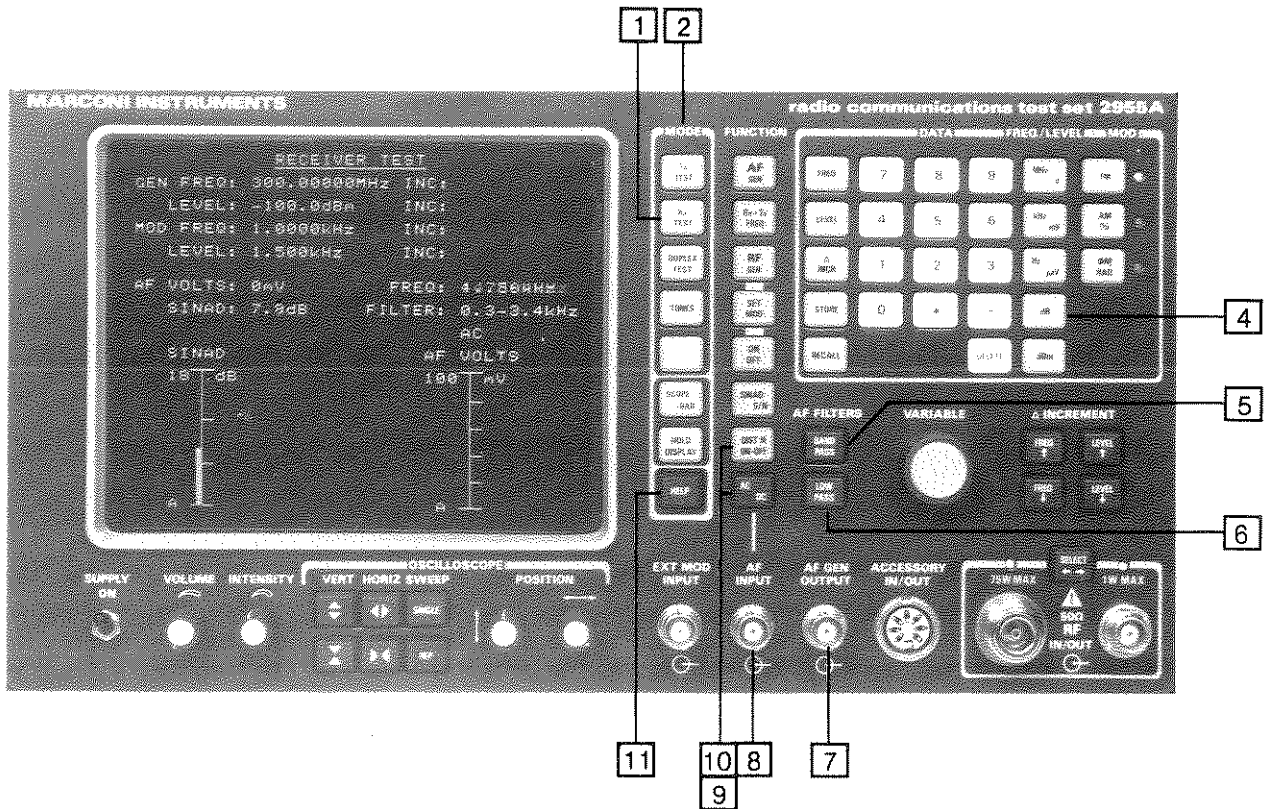

Fig. 3-8 AF voltmeter controls and connectors

## AF voltmeter controls and connectors

- 1 **RX TEST key.** Connects the AF voltmeter to the AF input socket 8. Writes on the screen information concerning instrument settings.
- 2 **MODE keys.** Used as soft keys to select programmed functions when menus are shown alongside on the screen.
- 3 Not used.
- 4 **dB key.** Selects dBV or dBr.
- 5 **BAND PASS key.** Selects a 0.3 to 3.4 kHz band-pass filter.
- 6 **LOW PASS key.** Selects a 300 Hz or a 50 kHz low-pass filter.
- 7 **AF GEN OUTPUT socket.** BNC socket. Used for the optional 600  $\Omega$  dBm and 20 dB Attenuator accessory. See under 'Accessories' in Chap. 1.
- 8 **AF INPUT socket.** BNC socket. For the AF or modulated DC input. Impedance 1 M $\Omega$ .
- 9 **AC DC key.** Changes the state of the input from the socket 8 between an AF or a modulated DC voltage. The display indicates when AC or DC is selected.

- [10] DIST'N ON-OFF key.** Set to OFF for dBV or dBr measurement.
- [11] HELP key.** Enables access to the CHANGE PARAMETERS menu for selection of the 600  $\Omega$  Balanced Converter and 20 dB Attenuator.

### AF voltmeter operation

- (1) Connect the unit under test to the AF INPUT socket **[8]**.
- (2) Select RX TEST **[1]**. The RECEIVER TEST display appears.
- (3) Press BAND PASS **[5]** to select the 0.3 to 3.4 kHz BP filter or press LOW PASS **[6]** once or twice as necessary to select a 300 Hz or 50 kHz LP filter.
- (4) To read AF volts, press the AC DC key **[9]** until AC is displayed.
- (5) To read DC plus AF volts, press the AC DC key **[9]** until DC is displayed. The 50 kHz filter is automatically selected. Note that the DC is shown with no sign but can be positive or negative.
- (6) To select dBV or dBr (dB relative to the entered level), set **[10]** to DIST'N OFF.
- (7) If required, change between dBV and dBr by pressing the dB key **[4]**.
- (8) To use the 600  $\Omega$  Balanced Converter (e.g. for testing telephone lines), connect it to the AF GEN OUTPUT **[7]** and to the AF INPUT **[8]** sockets. To change the AF voltage readings into dBm (into 600  $\Omega$ ), press the HELP key **[11]**. Then select the CHANGE PARAMETERS option and continue as described under '600  $\Omega$  Balanced Converter selection' in Chap. 3-7. When ON is selected, dBV or dBr changes to dBm.



## DISTORTION METER

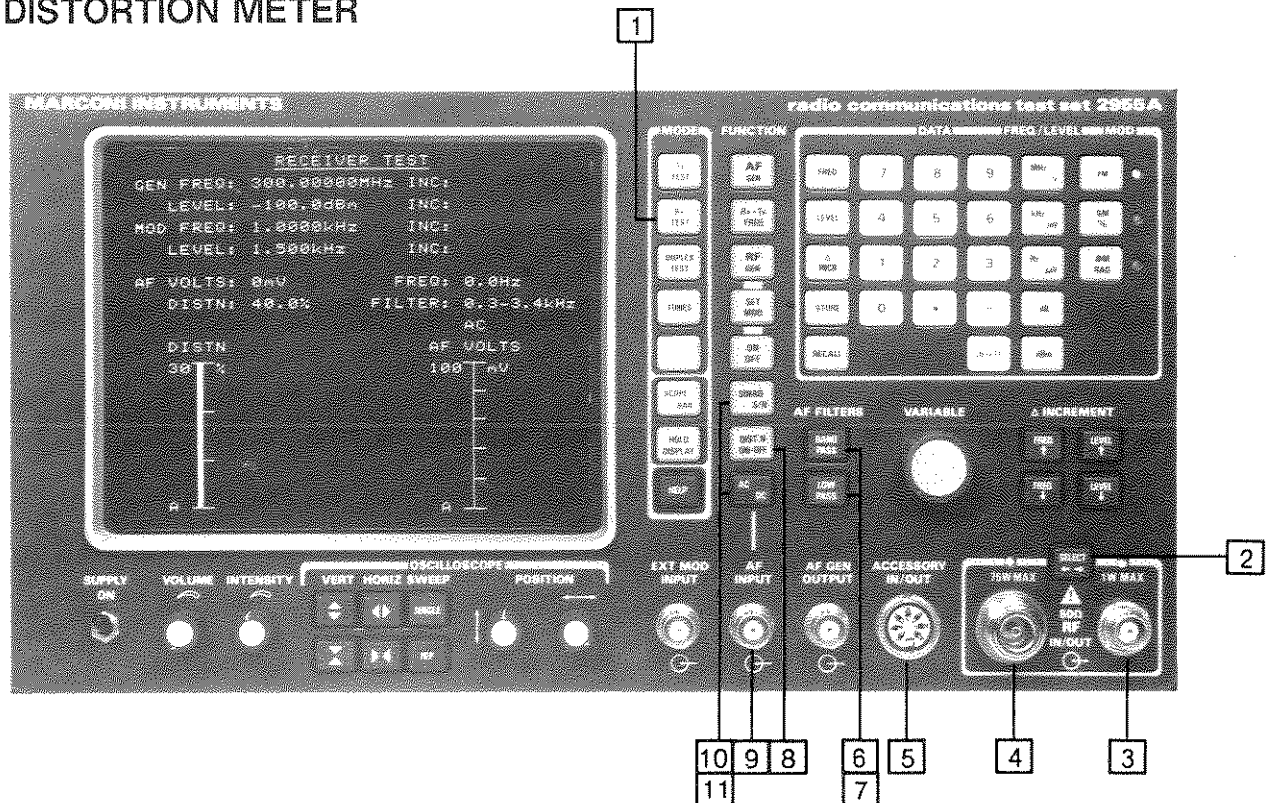

Fig. 3-9 Distortion meter controls and connectors

### Distortion meter controls and connectors

- 1 **RX TEST key.** Connects the RF generator output to RF IN/OUT BNC and N sockets 4 and 5 and connects the distortion meter to the AF INPUT socket 7. Writes on the screen information concerning instrument settings.
- 2 **SELECT key and LEDs.** For selecting RF IN/OUT socket 4 or 5. LED lights above the socket selected.
- 3 **RF IN/OUT BNC socket.** For RF generator output levels up to 225 mV. Impedance 50  $\Omega$ .
- 4 **RF IN/OUT N socket.** For RF generator output levels up to 22.5 mV. Impedance 50  $\Omega$ .
- 5 **ACCESSORY socket.** DIN 7-pin connector for an external psophometric (telephone weighting) CCITT or C-message filter option.
- 6 **BAND PASS key.** Selects a 0.3 to 3.4 kHz band-pass filter.
- 7 **LOW PASS key.** Selects a 300 Hz or a 50 kHz low-pass filter.
- 8 **DIST'N ON-OFF key.** Causes the AF generator to modulate the RF generator with a 1 kHz tone.

- 9 AF INPUT socket. BNC socket. For the AF input. Impedance 1 MΩ.
- 10 AC DC key. This key is disabled and AC automatically selected whenever DIST'N 5 or SINAD or S/N 9 is selected.
- 11 SINAD S/N key. Selects SINAD or signal/noise. When SINAD is selected, causes the AF generator to modulate the RF generator with a 1 kHz tone. The display indicates when SINAD or S/N is selected.

### Distortion meter operation

To make a receiver distortion measurement, proceed as follows:-

- (1) Select RX TEST 1 . The RECEIVER TEST display appears.
- (2) Set the RF generator to the frequency of the receiver under test (as under 'RF generator operation').
- (3) Connect the receiver's antenna input to either the BNC socket 3 or the N socket 4 .
- (4) Connect the receiver's audio output to the AF INPUT socket 9 .
- (5) Press the DIST'N ON-OFF key 8 until DISTN is displayed. AC coupling and the 0.3 to 3.4 kHz band-pass filter are automatically selected.
- (6) Press LOW PASS 7 once or twice as necessary to select a 300 Hz or 50 kHz LP filter. Press BAND PASS 6 to return to the 0.3 to 3.4 kHz BP filter.
- (7) Read the % distortion from the display.
- (8) If required, connect an external psophometric filter to the ACCESSORY socket 5 and the radio's audio output to the filter. Correct connection is denoted by the display showing either CCITT or C-message in place of any previously selected internal filter.
- (9) Press the SINAD S/N key 11 until SINAD is displayed. AC coupling and the 0.3 to 3.4 kHz band-pass filter are automatically selected.
- (10) Read the SINAD in dB from the display.
- (11) Press the SINAD S/N key 11 until S/N is displayed.
- (12) Read the S/N in dB from the display.
- (13) To return to normal operation, select DIST'N OFF using key 8 .

## Chapter 3-4

# DUPLEX TESTING

Controls and connectors	...	...	...	...	...	...	...	...	...	Page
Operation	...	...	...	...	...	...	...	...	...	3-31
Tones menu	...	...	...	...	...	...	...	...	...	3-32
Modulation and AF setup	...	...	...	...	...	...	...	...	...	3-33

**Fig.**  
3-10 Duplex testing controls and connectors ... .. 3-31

### CONTROLS AND CONNECTORS

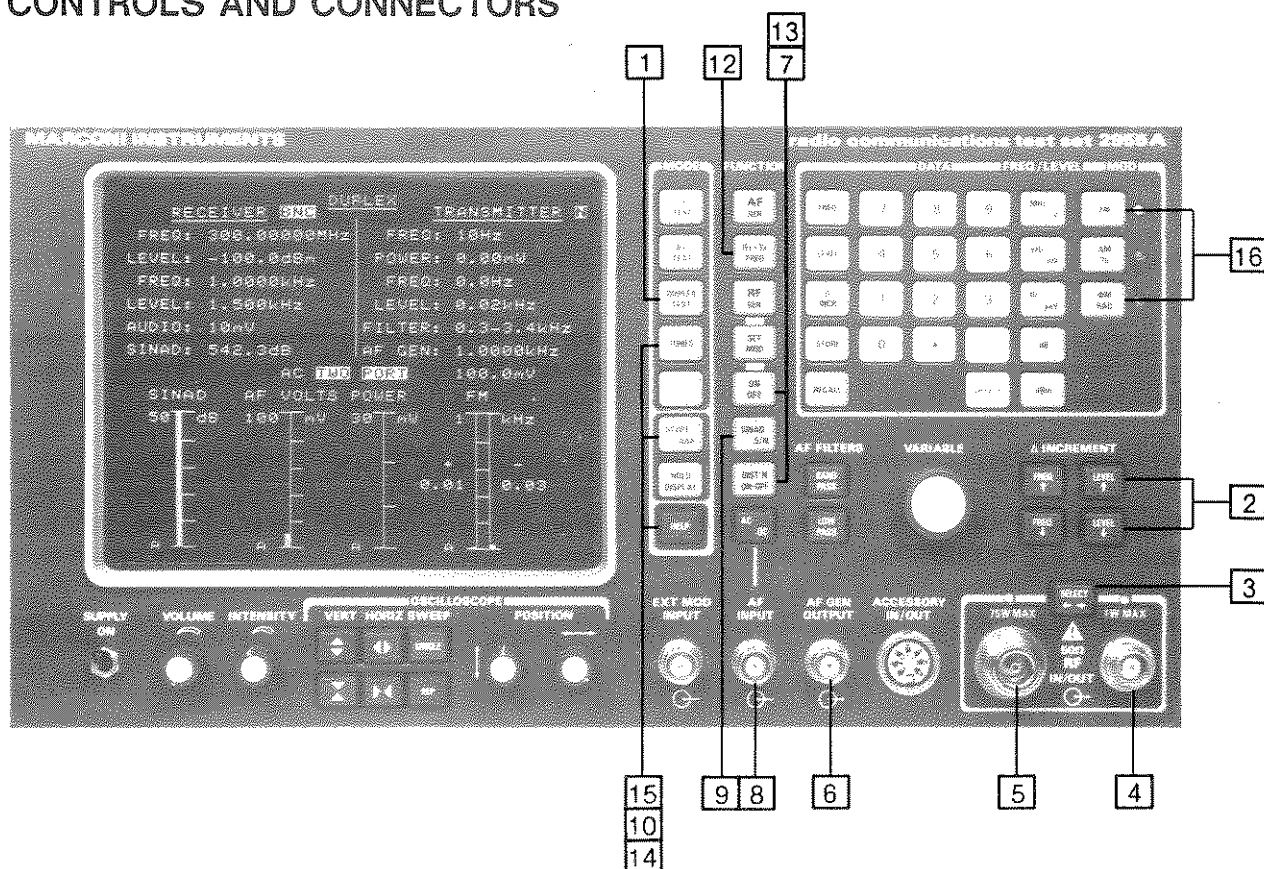

*Fig. 3-10 Duplex testing controls and connectors*

- 1 **DUPLEX TEST** key. Used to select the DUPLEX test mode. Connects the RF generator to RF IN/OUT socket 4 or 5, the modulation meter and the power meter to socket 5 and the distortion meter to socket 8.
- 2 **Δ INCREMENT** keys. Only operable when the RF generator step value has previously been set in the RECEIVER TEST mode.
- 3 **SELECT** key. Used to select one-port or two-port operation.

- [4] RF IN/OUT BNC socket.** Connects the RF generator to the receiver input for two-port operation. Impedance 50  $\Omega$ .
- [5] RF IN/OUT N socket.** Connects the input from the transmitter for two-port operation or simultaneous input from the transmitter and output from the RF generator for one-port operation. A temperature sensor detects excessive power. Impedance 50  $\Omega$ .
- [6] AF GEN OUTPUT socket.** BNC socket. For output for modulating the transmitter in deviation measurements.
- [7] DIST'N ON-OFF key.** Causes the AF generator to modulate the RF generator with a 1 kHz tone.
- [8] AF INPUT socket.** BNC socket. For the AF input for distortion or SINAD measurements. Impedance 1 M $\Omega$ .
- [9] SINAD S/N key.** Selects SINAD or signal/noise. When SINAD is selected, causes the AF generator to modulate the RF generator with a 1 kHz tone. The display indicates when SINAD or S/N is selected.
- [10] SCOPE/BAR key.** Disabled as bar charts only are displayed in the DUPLEX test mode.
- [12] RX=TX FREQ key.** Can be used to set the RF generator to the transmitter frequency. When there is an RX to TX frequency offset, it is followed by an increment key which has been preset to the appropriate offset.
- [13] ON OFF key.** Enables and disables the modulation and AF generators.
- [14] HELP key.** Enables access to the CHANGE PARAMETERS menu for selection of the RX/TX MOD TYPE LOCK option.
- [15] TONES key.** Used to select the TONES menu.
- [16] MOD keys.** Enable the type of modulation to be entered. LED lights to show FM, AM or  $\Phi$ M.

## OPERATION

Proceed as follows:-

- (1) Press DUPLEX TEST **[1]** . The DUPLEX test display appears. The current instrument settings are shown under RECEIVER and TRANSMITTER headings.
- (2) Select one-port operation by pressing the SELECT key **[3]** until ONE PORT is displayed in reverse video with the LED lit above socket **[5]** .
- (3) Select two-port operation by pressing the SELECT key **[3]** until TWO PORT is displayed in reverse video with both LEDs lit. Additionally, BNC and N are displayed in reverse video to indicate that the connections are the receiver to BNC socket **[4]** and the transmitter to N socket **[5]** .

- (4) Set the receiver's frequency and set the RF generator frequency, level and modulation (as under these headings in 'RF generator operation'). Note, however, that the  $\Delta$  INCREMENT keys [2] are only operable when the RF generator step value had previously been set in the RECEIVER TEST mode. Note also that the maximum RF generator output level is -21.2 dBm for one-port and -15 dBm for two-port operation.
- (5) Connect the receiver input to either the N socket [5] for one-port operation or to the BNC socket [4] for two-port operation.
- (6) Set the transmitter's frequency, level and modulation. To set the type of modulation to be the same or not the same as the receiver's type of modulation, press the HELP key [14]. Then select the CHANGE PARAMETERS option. On PAGE 2 of the menu, select ON or OFF under the RX/TX MOD TYPE LOCK option. When the selection is OFF, use the MOD keys [16] to set the transmitter's type of modulation.
- (7) Connect the transmitter's output to the N socket [5] for both one-port and two-port duplex operation.
- (8) Read the transmitter's RF power and modulation parameters from the display. Note that, for the DUPLEX test mode, the bar chart display is required and therefore the SCOPE/BAR key [10] is disabled. Note also that the audio filter value is displayed under the TRANSMITTER side of the display but applies to both transmitter and receiver measurements.
- (9) Connect the AF GEN OUTPUT socket [6] to the transmitter's microphone input.
- (10) Connect the receiver's audio output to the AF INPUT socket [8].
- (11) Press DIST'N ON [7], SINAD or S/N [9] and read the receiver's distortion, SINAD or signal/noise ratio from the display.

## TONES MENU

This gives access to the DUPLEX MOD AND AF SETUP menu as described below in addition to other options which are described in Chap. 3-6.

In the DUPLEX test mode, press the TONES key [15]. The TONES menu appears.

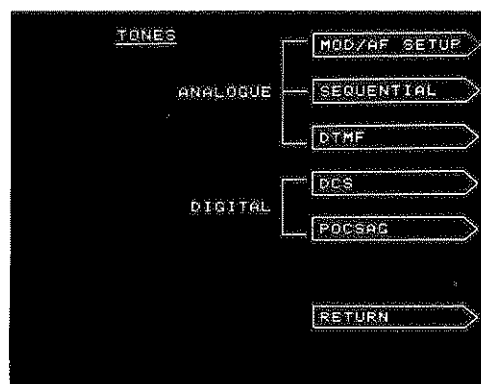

## MODULATION AND AF SETUP

Under the TONES menu, press the MOD/AF SETUP key. The DUPLEX MOD AND AF SETUP menu appears.

This menu is an alternative display under which the modulation and AF generator frequencies and levels can be set, all being shown together. In addition, generators can be enabled and disabled and the waveforms can be selected.

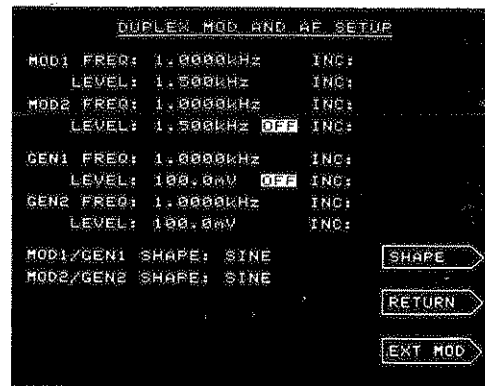

To enable or disable the generators, select the generator and then use the ON OFF key **[13]** to select enabled or OFF. When both of the modulation or AF generators are enabled, 2T (two tone) is shown on the display.

To change a waveform, select the modulation generator and then use the SHAPE key to select SINE, SQUARE, TRIANGLE or SAW TOOTH.

To control the external modulation, press the EXT MOD key. The EXTERNAL MOD INPUT frequency and level appear. These can be set as for the internal modulation. To enable and disable the external modulation, use the key which is arrowed by ON and OFF alternately.

Pressing RETURN restores the DUPLEX test display.

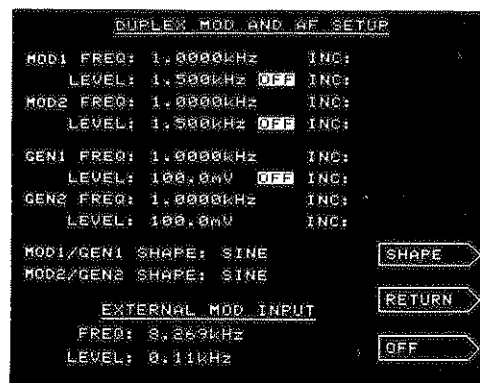

## Chapter 3-5

# AUDIO TESTING

	<b>Page</b>
AF generators ... ..	3-36
AF generator controls and connectors ... ..	3-36
AF generator operation ... ..	3-37
TONES menu ... ..	3-39
Audio setup ... ..	3-39
AF voltmeter ... ..	3-41
AF voltmeter controls and connectors ... ..	3-41
AF voltmeter operation ... ..	3-42
Distortion meter... ..	3-43
Distortion meter controls and connectors ... ..	3-43
Distortion meter operation ... ..	3-44
<b>Fig.</b>	
3-11 AF generator controls and connectors ... ..	3-36
3-12 AF voltmeter controls and connectors ... ..	3-41
3-13 Distortion meter controls and connectors ... ..	3-43

## AF GENERATORS

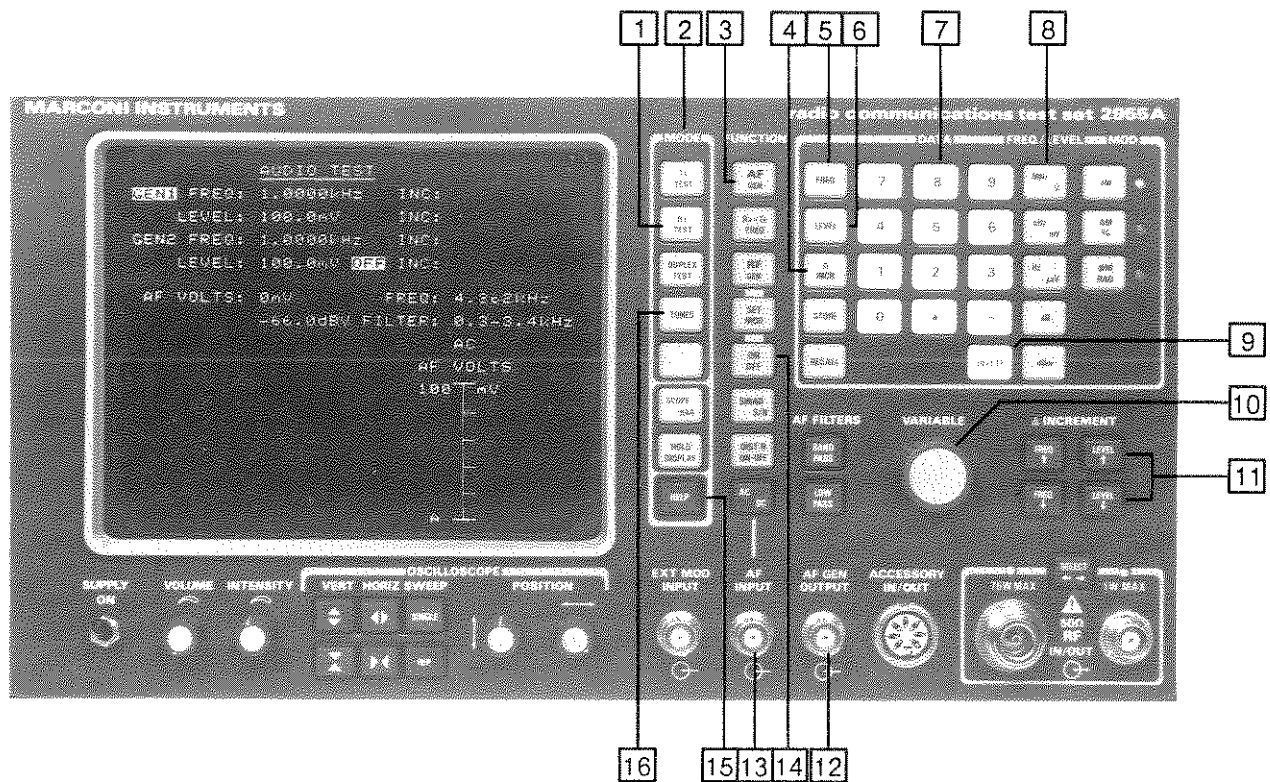

Fig. 3-11 AF generator controls and connectors

### AF generator controls and connectors

- 1 RX TEST key. Used with 3 to select the AUDIO TEST mode.
- 2 MODE keys. Used as soft keys to select programmed functions when menus are shown alongside on the screen.
- 3 AF GEN key. Used with 1 to select the AUDIO TEST mode.
- 4  $\Delta$  INCR key. Follows a FREQ 5 or LEVEL 6 entry so that the entered data is recognized as an increment or decrement.
- 5 FREQ key. Precedes a keypad 7 entry so that the entered data is recognized as a frequency.
- 6 LEVEL key. Precedes a keypad 7 entry so that the entered data is recognized as a level.
- 7 DATA keypad. For data entry using numerals 0 to 9, decimal point and minus sign.
- 8 FREQ/LEVEL keys. For defining units of frequency or level. One of these terminates the data entry.



- 9 **DELETE key.** Deletes a preceding digit, decimal point or minus sign which has been entered on the keypad **7** .
- 10 **VARIABLE control.** Analogue control which varies the smallest increment of the function data. Step size is independent of **4** and depends upon range. The level or frequency assignment is shown in reverse video on the screen.
- 11 **Δ INCREMENT keys.** Increase and decrease the frequency and the level by the increments which have been set using **4** .
- 12 **AF GEN OUTPUT socket.** BNC socket. Supplies one or two outputs in the range 10 Hz to 20 kHz for single-tone or two-tone operation. Impedance <math>< 5 \Omega</math>.
- 13 **AF INPUT socket.** BNC socket. For the audio input. Impedance  $1 \text{ M}\Omega$ .
- 14 **ON OFF key.** Enables and disables the AF generators.
- 15 **HELP key.** Enables access to the CHANGE PARAMETERS menu for selection of the  $600 \Omega$  Balanced Converter and 20 dB Attenuator.
- 16 **TONES key.** Used to select the TONES menu.

## AF generator operation

AF generator operation consists of initial actions (1) to (4) and then, for one or both of the two AF generators, AF frequency setting (5) to (7) and level setting (8) to (11) as follows:-

- (1) Select RX TEST **1** . The RECEIVER TEST display appears.
- (2) Press AF GEN **3** . This selects the AUDIO TEST mode and the first AF generator. GEN1 is shown in reverse video on the screen. To select the second AF generator, press AF GEN **3** followed by 2 on the keypad **7** . After this, use AF GEN **3** followed by 1 on the keypad **7** when you require to go back to the first AF generator. Initially, the first AF generator is enabled and the second is OFF, as shown on the display. To enable and disable the generators, see later under 'Audio setup'.
- (3) Connect the unit under test to the AF GEN OUTPUT socket **12** .
- (4) To use the  $600 \Omega$  Balanced Converter (e.g. for testing telephone lines), connect it to the AF GEN OUTPUT **12** and to the AF INPUT **13** sockets. To change the AF voltage readings to dBm (into  $600 \Omega$ ), press the HELP key **15** . Then select the CHANGE PARAMETERS option and continue as described under '600  $\Omega$  Balanced Converter selection' in Chap. 3-7. When ON is selected, dBm appears in place of voltage.

- (5) Select FREQ **5** . The frequency to be changed is shown in reverse video. Enter the data on the keypad **7** , ending with the frequency terminator **8** . To enter 1.235 kHz, use the following:-



If a mistake is made during data entry, press DELETE **9** and then enter the correct character. When, however, the terminator **8** has been pressed, re-enter the complete data. If incorrect data has been entered (e.g. a frequency outside the range of the instrument), the terminator is ignored and the entry is not be accepted. Use DELETE and then re-enter the data.

- (6) If required, set the frequency increment/decrement by selecting  $\Delta$  INCR **4** and entering the data, ending with the frequency terminator. To enter 500 Hz steps, use the following:-



In the example, FREQ can be omitted since it has been previously entered in (5).

- (7) Having set the step size, the frequency can be adjusted by repeatedly pressing one of the  $\Delta$  INCREMENT keys **11** , FREQ  $\uparrow$  for an increment or FREQ  $\downarrow$  for a decrement. For fine frequency control, use the VARIABLE control **10** .
- (8) Select LEVEL **6** . The level to be changed is displayed in reverse video. Enter the data on the keypad **7** , ending with the level terminator **8** . To enter 50 mV, use the following:-



- (9) If required, set the level increment/decrement by selecting  $\Delta$  INCR **4** and entering the data, ending with the level terminator. To enter 200 mV steps, use the following:-



In the example, LEVEL can be omitted since it has been previously entered in (8).

- (10) Having set the step size, the level can be adjusted by repeatedly pressing one of the  $\Delta$  INCREMENT keys **11** , LEVEL  $\uparrow$  for an increment or LEVEL  $\downarrow$  for a decrement. For fine level control, use the VARIABLE control **10** .

- (11) To use the 20 dB Attenuator, connect it to the AF GEN OUTPUT socket [12]. To change the level reading, press the HELP key [15]. Then select the CHANGE PARAMETERS option and continue as described under '20 dB Attenuator selection' in Chap. 3-7. When ON is selected, a reverse video A is displayed and the displayed AF generator level is decreased by a factor of 10 (20 dB).

## TONES menu

This gives access to the AUDIO SETUP menu as described below in addition to other options which are described in Chap. 3-6.

In the AUDIO TEST mode, press the TONES key [15]. The TONES menu appears.

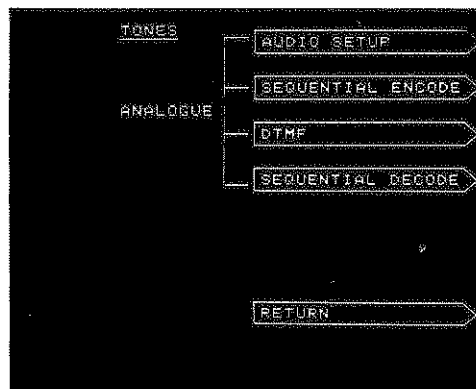

## Audio setup

Under the TONES menu, press the AUDIO SETUP key. The AUDIO SETUP menu appears.

This menu is an alternative display under which the AF generator frequencies and levels can be set, both being shown together. In addition, the AF generators can be enabled and disabled, the levels can be locked together and the waveforms can be selected.

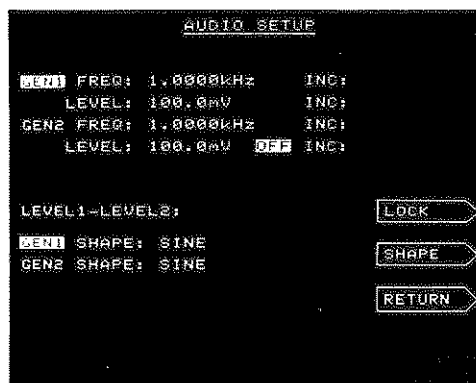

To enable or disable the AF generators, select the generator (as described under 'AF generator operation') and then use the ON OFF key **[14]** to select enabled or OFF. When both AF generators are enabled, 2T (two tone) is shown on the display.

To lock the level of GEN2 so that it is the same as the level of GEN1, press the LOCK key to select LOCKED.

To change a waveform, select the AF generator and then use the SHAPE key to select SINE, SQUARE, TRIANGLE or SAW TOOTH.

Pressing RETURN restores the AUDIO TEST display.

## AF VOLTMETER

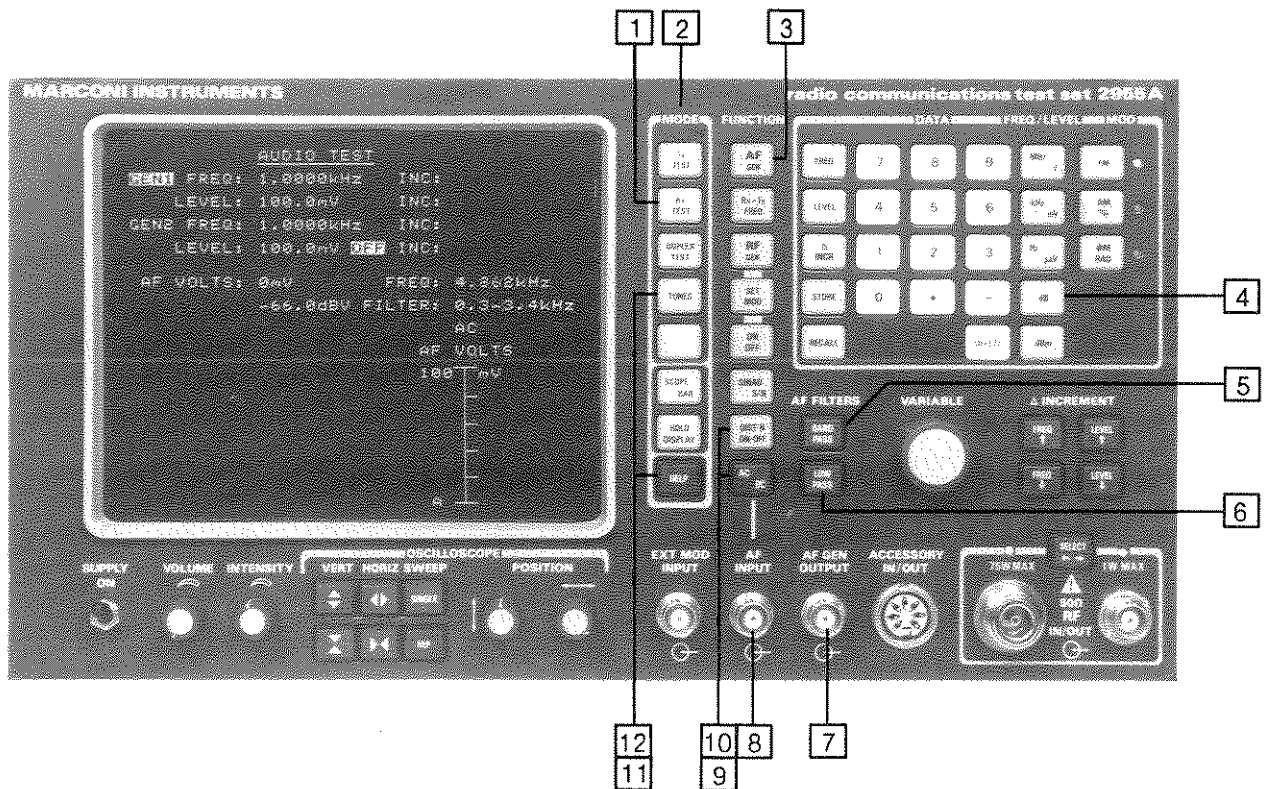

Fig. 3-12 AF voltmeter controls and connectors

### AF voltmeter controls and connectors

- 1 RX TEST key. Used with 3 to select the AUDIO TEST mode.
- 2 MODE keys. Used as soft keys to select programmed functions when menus are shown alongside on the screen.
- 3 AF GEN key. Used with 1 to select the AUDIO TEST mode.
- 4 dB key. Selects dBV or dB<sub>r</sub>.
- 5 BAND PASS key. Selects a 0.3 to 3.4 kHz band-pass filter.
- 6 LOW PASS key. Selects a 300 Hz or a 50 kHz low-pass filter.
- 7 AF GEN OUTPUT socket. BNC socket. Used for the optional 600 Ω dBm and 20 dB Attenuator accessory. See under 'Accessories' in Chap. 1.
- 8 AF INPUT socket. BNC socket. For the AF or modulated DC input. Impedance 1 MΩ.
- 9 AC DC key. Changes the state of the input from the socket 8 between an AF or a modulated DC voltage. The display indicates when AC or DC is selected.

- [10] **DIST'N ON-OFF key.** Set to OFF for dBV or dBr measurement.
- [11] **HELP key.** Enables access to the CHANGE PARAMETERS menu for selection of the 600  $\Omega$  Balanced Converter and 20 dB Attenuator.
- [12] **TONES key.** Used to select the TONES menu.

## AF voltmeter operation

In the AUDIO TEST mode, AF generator operation is enabled in addition to the AF voltmeter. This permits the AF generators to be tuned while the voltmeter readings are noted. This can be used to plot the characteristics of a filter or an amplifier which is connected between the AF GEN OUTPUT and the AF INPUT sockets. Proceed as follows:-

- (1) Connect the unit under test to the AF INPUT socket [8] .
- (2) Select RX TEST [1] . The RECEIVER TEST display appears.
- (3) Press AF GEN [3] . The AUDIO TEST display appears.
- (4) Press BAND PASS [5] to select the 0.3 to 3.4 kHz filter or press LOW PASS [6] once or twice as necessary to select a 300 Hz or 50 kHz filter.
- (5) To read AF volts, press the AC DC key [9] until AC is displayed.
- (6) To read DC plus AF volts, press the AC DC key [9] until DC is displayed. The 50 kHz filter is automatically selected. Note that the DC is shown with no sign but can be positive or negative.
- (7) To select dBV or dBr (dB relative to the entered level), set [10] to DIST'N OFF.
- (8) If required, change between dBV and dBr by pressing the dB key [4] .
- (9) To use the 600  $\Omega$  Balanced Converter (e.g. for testing telephone lines), connect it to the AF GEN OUTPUT [12] and to the AF INPUT [13] sockets. To change the AF voltage readings to dBm (into 600  $\Omega$ ), press the HELP key [15] . Then select the CHANGE PARAMETERS option and continue as described under '600  $\Omega$  Balanced Converter selection'.
- (10) To use the 20 dB Attenuator, connect it to the AF GEN OUTPUT socket [7] . To change the level reading, press the HELP key [11] . Then select the CHANGE PARAMETERS option and continue as described under '20 dB Attenuator selection' in Chap. 3-7. When ON is selected, a reverse video A is displayed and the displayed AF generator level is decreased by a factor of 10 (20 dB).

## DISTORTION METER

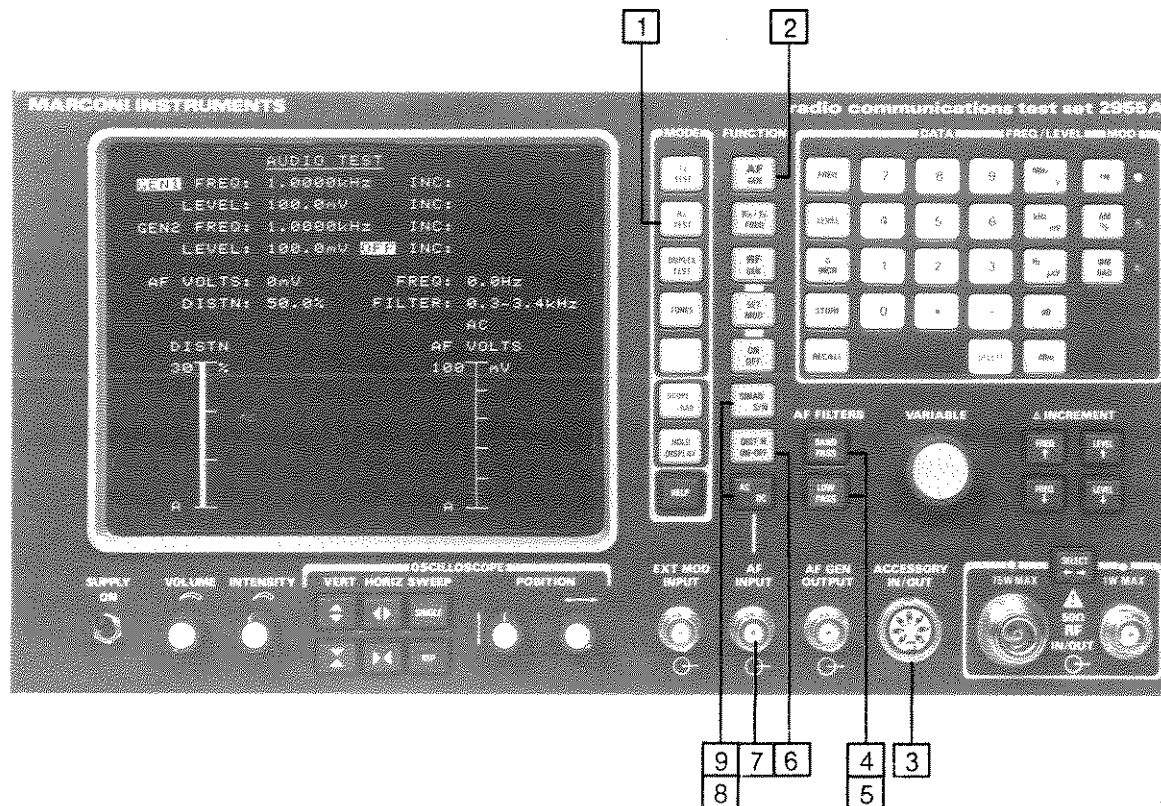

Fig. 3-13 Distortion meter controls and connectors

### Distortion meter controls and connectors

- 1 RX TEST key. Used with 2 to select the AUDIO TEST mode.
- 2 AF GEN key. Used with 1 to select the AUDIO TEST mode.
- 3 ACCESSORY socket. DIN 7-pin connector for an external psophometric (telephone weighting) CCITT or C-message filter option.
- 4 BAND PASS key. Selects a 0.3 to 3.4 kHz band-pass filter.
- 5 LOW PASS key. Selects a 300 Hz or a 50 kHz low-pass filter.
- 6 DIST'N ON-OFF key. Causes the AF generator to modulate the RF generator with a 1 kHz tone.
- 7 AF INPUT socket. BNC socket. For the AF input. Impedance 1 M $\Omega$ .
- 8 AC DC key. This key is inoperative. AC is automatically selected whenever DIST'N 6.
- 9 SINAD S/N key. This key is inoperative.

## Distortion meter operation

In the AUDIO TEST mode, AF generator is enabled in addition to the distortion meter. This enables an AF generator to supply the signal for distortion measurements (e.g. to test an audio amplifier which is connected between the AF GEN OUTPUT and the AF INPUT sockets). Proceed as follows:-

- (1) Connect the unit under test to the AF INPUT socket [7] .
- (2) Select RX TEST [1] . The RECEIVER TEST display appears.
- (3) Press AF GEN [2] . The AUDIO TEST display appears.
- (4) Press the DIST'N ON-OFF key [6] until DISTN is displayed. AC coupling and the 0.3 to 3.4 kHz band-pass filter are automatically selected.
- (5) Press LOW PASS [5] once or twice as necessary to select a 300 Hz or 50 kHz LP filter. Press BAND PASS [4] to return to the 0.3 to 3.4 kHz filter.
- (6) Read the % distortion from the display.
- (7) If required, connect an external psophometric filter to the ACCESSORY socket [6] and the audio output to the filter.
- (8) To return to normal operation, select DIST'N OFF using key [6] .



## Chapter 3-6

# SIGNALLING CODES TESTING

	Page
Controls and connectors ... ..	3-46
Sequential tones operation ... ..	3-48
Transmitter testing ... ..	3-48
Receiver testing ... ..	3-50
Duplex testing ... ..	3-53
Audio testing ... ..	3-53
Revertive sequential tones operation ... ..	3-57
DTMF (dual-tone multi-frequency) operation ... ..	3-59
Transmitter testing ... ..	3-59
Receiver testing ... ..	3-60
Duplex testing ... ..	3-61
Audio testing ... ..	3-61
DCS (digitally-coded squelch) operation ... ..	3-62
Transmitter testing ... ..	3-62
Receiver testing ... ..	3-63
Duplex testing ... ..	3-64
POCSAG radio pager testing ... ..	3-65
<b>Table</b>	
3-1 Sequential tones standards ... ..	3-49
<b>Fig.</b>	
3-14 Controls and connectors for signalling codes testing ... ..	3-46

CONTROLS AND CONNECTORS

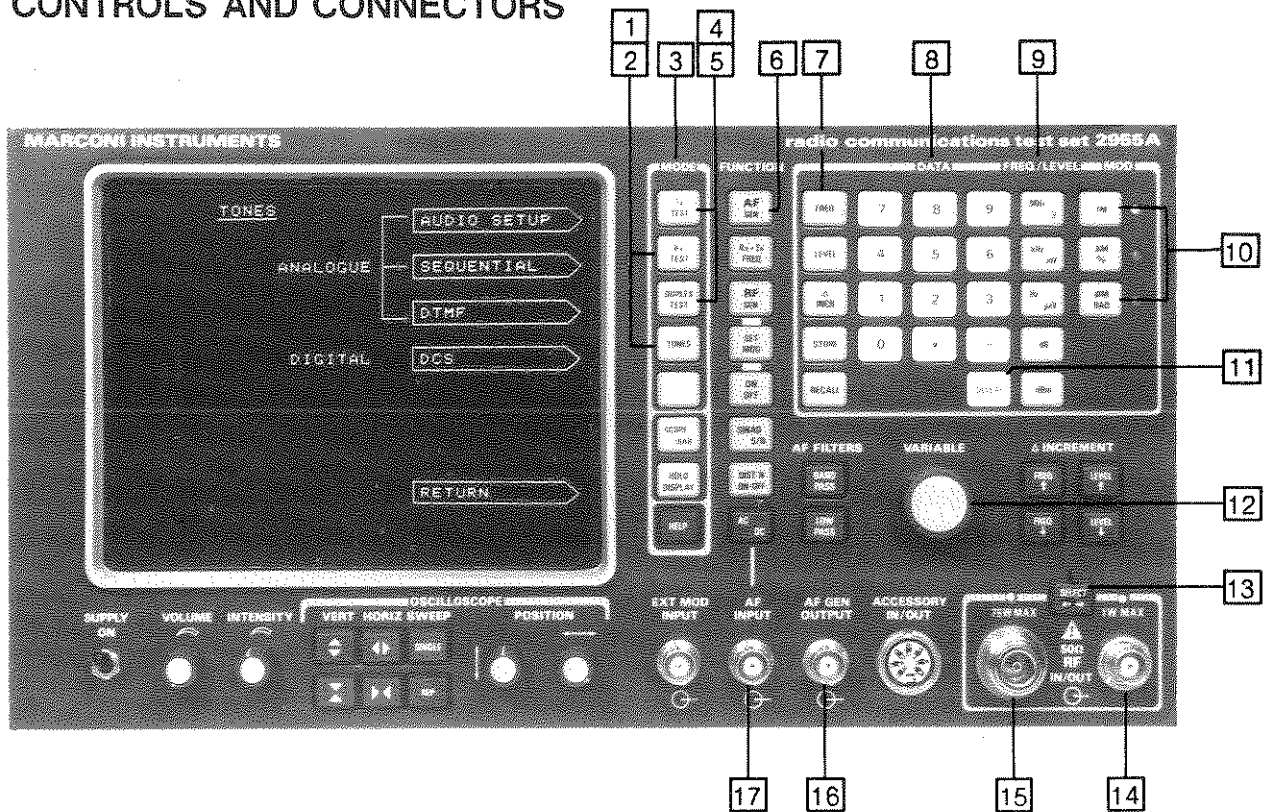

Fig. 3-14 Controls and connectors for signalling codes testing

- 1 **TONES key.** According to the test mode, causes one of the TONES menus to be displayed.
- 2 **RX TEST key.** Connects the RF generator output to RF IN/OUT sockets 14 and 15 and writes RECEIVER TEST on the screen.
- 3 **MODE keys.** These are used as soft keys to select programmed functions from menus which are shown alongside on the screen.
- 4 **TX TEST key.** Connects the modulation meter to sockets 14 and 15 and writes TRANSMITTER TEST on the screen.
- 5 **DUPLEX TEST key.** Connects the RF generator to sockets 14 and 15.
- 6 **AF GEN key.** Used with 2 to select the AUDIO TEST mode.
- 7 **FREQ key.** Precedes a keypad 8 entry so that the entered data is recognized as a frequency.
- 8 **DATA keypad.** For data entry using numerals 0 to 9, decimal point and minus sign.
- 9 **FREQ/LEVEL keys.** For defining units for frequency or level. Terminates the data entry.

- [10] MOD keys.** Enable the type of modulation to be entered. LED lights to show FM, AM or  $\Phi$ M.
- [11] DELETE key.** Deletes a preceding digit, decimal point or minus sign which has been entered on the keypad **[8]** .
- [12] VARIABLE control.** Analogue control which provides an alternative to **[7]** for entering data.
- [13] SELECT key and LEDs.** For selecting the RF IN/OUT BNC socket **[14]** or N socket **[15]** .
- [14] RF IN/OUT BNC socket.** For the RF generator output for two-port duplex operation. Impedance  $50 \Omega$ .
- [15] RF IN/OUT N socket.** For tones simplex or one-port duplex operation. A temperature sensor detects excessive power being applied. Impedance  $50 \Omega$ .
- [16] AF GEN OUTPUT socket.** BNC socket. Supplies one or two outputs in the range 10 Hz to 20 kHz for single-tone modulation or two-tone modulation. Impedance  $<5 \Omega$ .
- [17] AF INPUT socket.** BNC socket. For the audio input. Impedance  $1 M\Omega$ .

## SEQUENTIAL TONES OPERATION

### Transmitter testing

The tones decoder accepts up to 33 successive tones, 11 on each of 3 pages, including inter-tone pauses. Press the NEXT PAGE key to access the next or the first page. The frequency range is 0.3 to 3.4 kHz, the duration is 20 ms to 1.2 s and the inter-tone pauses are up to 800 ms.

To receive a programmed tones sequence, proceed as follows:-

- (1) Select TX TEST 4 . The TRANSMITTER TEST display appears.
- (2) Connect the output of the unit under test to either the RF IN/OUT BNC socket 14 or N socket 15 . Press SELECT 13 until the LED lights above the selected socket.
- (3) Key up the transmitter and ensure that the instrument is correctly tuned to the transmitter's frequency.
- (4) Select TONES 1 . From the TONES menu, select SEQUENTIAL. The SEQUENTIAL TONES menu appears.
- (5) To return to the TRANSMITTER TEST display at any time, press the key which is arrowed by RETURN.
- (6) From the options on the SEQUENTIAL TONES menu, select the required frequency standard as shown in Table 3-1. As supplied, each 2955A is programmed either for EEA (European) or for EIA (North American) standards. EEA or EIA is shown on the display. Use the MODE key 3 which is arrowed by the frequency standard (e.g. CCIR). The appropriate TX SEQUENTIAL TONES menu is displayed is (e.g. CCIR).

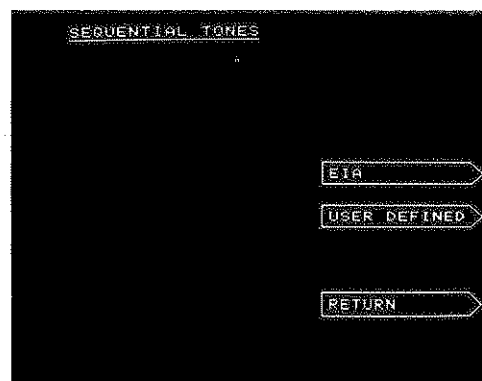
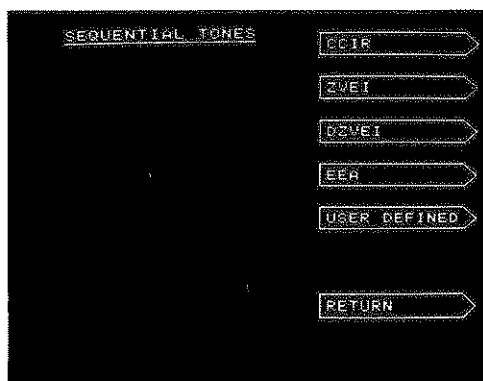
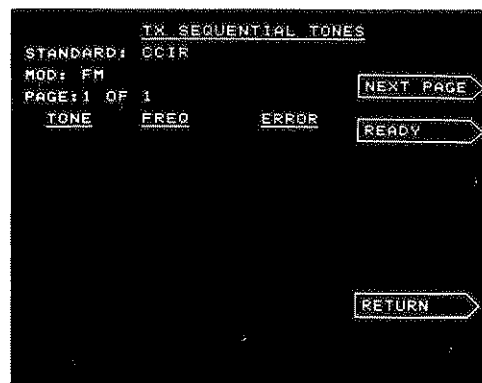

TABLE 3-1 SEQUENTIAL TONES STANDARDS

Tone number	Frequency				
	CCIR Hz	ZVEI Hz	DZVEI Hz	EIA Hz	EEA Hz
0	1981	2400	2200	600	1981
1	1124.6	1060.6	970	741	1124
2	1197	1160	1060.6	882.5	1197
3	1275	1270	1160	1023	1275
4	1358	1400	1270	1164	1358
5	1446	1530	1400	1305	1446
6	1540	1670	1530	1446	1540
7	1640	1830	1670	1587	1640
8	1747	2000	1830	1728	1747
9	1860	2200	2000	1869	1860
10	2400	2800	2400	459	1055
11	930	810	2600	1000	930
12	2247	970	885	1000	2247
13	991	885	825	1000	991
14	2110	2600	810	1000	2110
Duration	100 ms	70 ms	70 ms	33 ms	40 ms
Extended	700 ms	700 ms	700 ms	330 ms	400 ms



- (7) On the transmitter, activate the tones which are to be measured. When triggered, the instrument displays ACTIVE.
- (8) At the end of each measurement, ACTIVE is removed and the received tone number, frequency and % error are displayed. If it is within 5% of a standard frequency, the closest tone number is displayed along with the associated error. If the error is worse than 2%, an asterisk is displayed next to the tone number.
- (9) For another test, press the key which is arrowed by RESET. This changes to READY. Otherwise, return to the TRANSMITTER TEST display by pressing RETURN.

To select a user-defined standard, execute (1) to (4) as above and then proceed as follows:-

- (5) From the options on the SEQUENTIAL TONES menu, select USER DEFINED. The USER DEFINED STANDARD menu appears with the current tone numbers and frequencies.

TONE	FREQ	USER DEFINED STANDARD
0	1.0000kHz	ENTER FREQ USING
1	1.1000kHz	DATA KEYS
2	73.6Hz	NEXT TONE
3	1.0000kHz	
4	1.4000kHz	ENTER TONE DURATION
5	66.4Hz	IN MS
6	1.6000kHz	DURATION
7	1.7000kHz	
8	59.2Hz	DURATION: 20ms
9	1.9000kHz	MS
10	2.0000kHz	CONTINUE
11	52.0Hz	
12	2.2000kHz	RETURN
13	2.3000kHz	
14	70.4Hz	

- (6) When a frequency change is required, press the key which is arrowed by NEXT TONE to step the flashing cursor to the required tone number under the frequency column. Any frequency between 20 Hz and 20 kHz can be assigned to any tone number. Increment sizes for the tone frequencies are 0.1 Hz from 20 Hz to 3.2766 kHz and 1 Hz from 3.277 kHz to 20 kHz. This user-defined data is stored in non-volatile memory.
- (7) Enter the frequency using the keypad [8], ending with the FREQ/LEVEL terminator key [9]. This moves the cursor down ready for the next entry.
- (8) Repeat (6) and (7) as necessary.
- (9) Press the key which is arrowed by CONTINUE to return to the SEQUENTIAL TONES menu.
- (10) Press the key which is arrowed by RETURN to return to the TRANSMITTER TEST display.

If the input level changes, go back to the TRANSMITTER TEST display so that the autoranging is reset.

## Receiver testing

To generate a programmed tones sequence in the RECEIVER TEST mode, proceed as follows:-

- (1) Select RX TEST [2]. The RECEIVER TEST display appears.
- (2) Connect the input of the unit under test to either the RF IN/OUT BNC socket [14] or N socket [15]. Press SELECT [13] until the LED lights above the selected socket.

- (3) Select TONES **1** . From the TONES menu, select SEQUENTIAL. The SEQUENTIAL TONES menu appears.

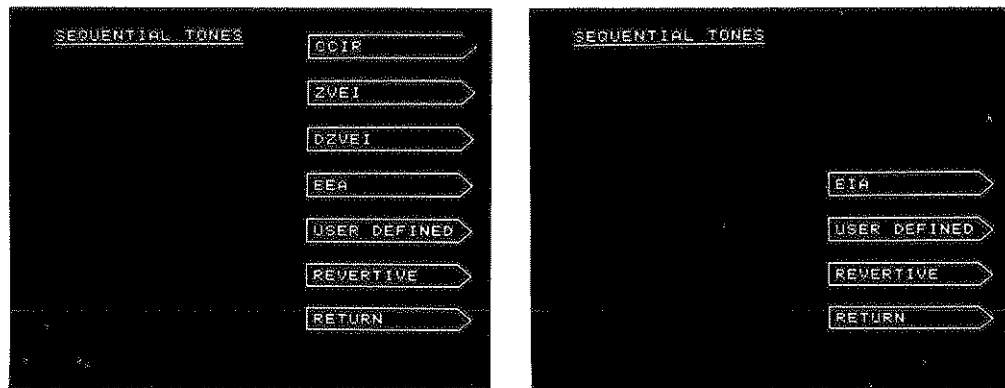

- (4) To return to the RECEIVER TEST display at any time, press the key which is arrowed by RETURN.
- (5) From the options on the SEQUENTIAL TONES menu, select the required frequency standard as described under 'Transmitter test' (e.g. CCIR). The appropriate RX SEQUENTIAL TONES menu appears.

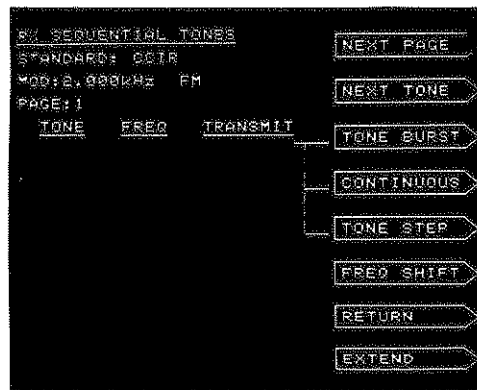

- (6) On PAGE 1, enter up to 11 tones by pressing the NEXT TONE key and then the tone number using the keypad **8** . To terminate each entry, press NEXT TONE again. This causes the frequency to be displayed against the entered tone number and moves the cursor down ready for the next entry.
- (7) To select PAGE 2 and then PAGE 3, press the NEXT PAGE key. A further 11 tones can be entered on each of these pages.
- (8) To create an inter-tone pause, press the key which is arrowed by NEXT TONE without entering a tone number. Repeat for multiples of the tone duration. Then, when the next tone number is entered, NULLs are displayed. A pause can be created in place of an entered frequency by moving the cursor appropriately and then pressing DELETE **11** .

- (9) To select an extended tone (of 10 times the tone duration up to 700 ms unless user-defined), press the key which is arrowed by EXTEND. This facility is used for scanning receivers to ensure capture of the first tone. The letter E is displayed alongside the altered tone frequency. The EXTEND arrow changes to CANCEL E. Press this key to revert to normal tones operation.
- (10) To generate the tones sequence, press the key which is arrowed by TONE STEP, TONE BURST or CONTINUOUS as required. The CONTINUOUS arrow changes to TONES STOP to enable the continuous operation to be interrupted.
- (11) If required, select a frequency offset in the range  $\pm 9\%$  by pressing the key which is arrowed by FREQ SHIFT. Enter the offset using one of the keys 0 to 9 with a minus sign when appropriate. All the previously selected tone frequencies are reset and displayed.
- (12) To return to the RECEIVER TEST display, press the key which is arrowed by RETURN. If CONTINUOUS has been selected, the tones continue to be transmitted.

To select a user-defined standard, execute (1) to (4) as above and then proceed as follows:-

- (5) From the options on the SEQUENTIAL TONES menu, select USER DEFINED. The USER DEFINED STANDARD menu appears with the current tone numbers and frequencies, as under 'Transmitter test'.
- (6) When a frequency change is required, press the key which is arrowed by NEXT TONE to step the flashing cursor to the required tone number under the frequency column. Any frequency between 20 Hz and 20 kHz can be assigned to any tone number. Increment sizes for the tone frequencies are 0.1 Hz from 20 Hz to 3.2766 kHz and 1 Hz from 3.277 kHz to 20 kHz. This user-defined data is stored in non-volatile memory.
- (7) Enter the frequency using the keypad  , ending with a FREQ/LEVEL terminator key  . This moves the cursor down ready for the next entry.
- (8) Repeat (6) and (7) as necessary.
- (9) Set the TONE DURATION by pressing the key which is arrowed by DURATION and then entering the duration in ms using the keypad  . Terminate by pressing the key which is arrowed by ms.
- (10) Press the key which is arrowed by CONTINUE to return to the SEQUENTIAL TONES menu.
- (11) Press the key which is arrowed by RETURN to return to the RECEIVER TEST display.



## Duplex testing

To generate a programmed tone sequence in the DUPLEX test mode, follow the instructions for interconnections and general operating procedures given in Chap. 3-4. Then, continue from (4) of 'Receiver test'.

Tones cannot be received in the DUPLEX test mode. To test the reception of a sequential tones sequence, leave the DUPLEX test mode and follow the instructions given in Chap. 3-2.

## Audio testing

To generate a programmed tones sequence in the AUDIO TEST mode, proceed as follows:-

- (1) Select RX TEST [2] and AF GEN [6]. The AUDIO TEST display appears.
- (2) Connect the input of the unit under test to the AF GEN OUTPUT socket [16].
- (3) Select TONES [1]. From the TONES menu, select SEQUENTIAL ENCODE. The SEQUENTIAL TONES menu appears.

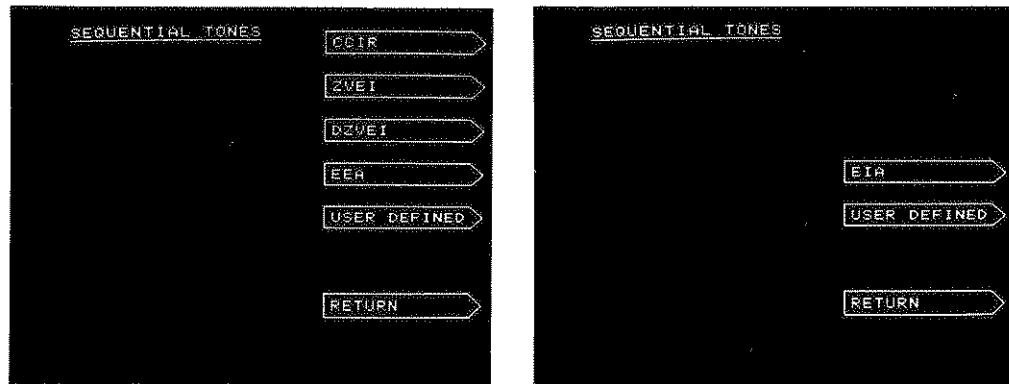

- (4) To return to the AUDIO TEST display at any time, press the key which is arrowed by RETURN.
- (5) From the options on the SEQUENTIAL TONES menu, select the required frequency standard as described under 'Transmitter testing' (e.g. CCIR). The appropriate AF SEQUENTIAL TONES menu appears.
- (6) On PAGE 1, enter up to 11 tones by pressing the NEXT TONE key and then the tone number using the keypad [8]. To terminate each entry, press NEXT TONE again. This causes the frequency to be displayed against the entered tone number and moves the cursor down ready for the next entry.

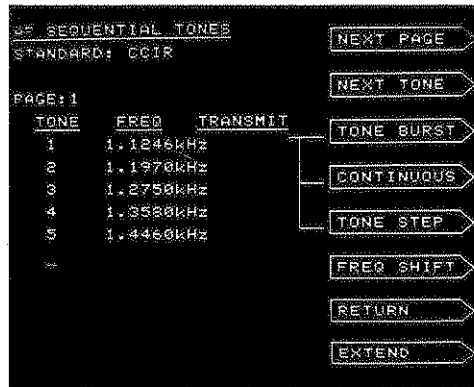

- (7) To select PAGE 2 and then PAGE 3, press the NEXT PAGE key. A further 11 tones can be entered on each of these pages.
- (8) To create an inter-tone pause, press the key which is arrowed by NEXT TONE without entering a tone number. Repeat for multiples of the tone duration. Then, when the next tone number is entered, NULLs are displayed. A pause can be created in place of an entered frequency by moving the cursor appropriately and then pressing DELETE [11].
- (9) To select an extended tone (of 10 times the tone duration up to 700 ms unless user-defined), press the key which is arrowed by EXTEND. This facility is used for scanning receivers to ensure capture of the first tone. The letter E is displayed alongside the altered tone frequency. The EXTEND arrow changes to CANCEL E. Press this key to revert to normal tones operation.
- (10) To generate the tones sequence, press the key which is arrowed by TONE STEP, TONE BURST or CONTINUOUS as required. The CONTINUOUS arrow changes to TONES STOP to enable the continuous operation to be interrupted.
- (11) If required, select a frequency offset in the range >9% by pressing the key which is arrowed by FREQ SHIFT. Enter the offset using one of the keys 0 to 9 with a minus sign when appropriate. All the previously selected tone frequencies are reset and displayed.
- (12) To return to the AUDIO TEST display, press the key which is arrowed by RETURN. If CONTINUOUS has been selected, the tones continue to be transmitted.

To select a user-defined standard, execute (1) to (3) as above and then proceed as follows:-

- (4) From the options on the SEQUENTIAL TONES menu, select USER DEFINED. The USER DEFINED STANDARD menu appears with the current tone numbers and frequencies, as under 'Transmitter testing'.
- (5) When a frequency change is required, press the key which is arrowed by NEXT TONE to step the flashing cursor to the required tone number under the frequency column. Any frequency between 10 Hz and 20 kHz can be assigned to any tone number. Increment sizes for the tone frequencies are 0.1 Hz from 20 Hz to 3.2766 kHz and 1 Hz from 3.277 kHz to 20 kHz. This user-defined data is stored in non-volatile memory.

- (6) Enter the frequency using the keypad [8] and the terminator key [9] . This moves the cursor down ready for the next entry.
- (7) Repeat (5) and (6) as necessary.
- (8) Set the tones reception period by pressing the key which is arrowed by DURATION and then entering the duration in ms using the keypad [8] . Terminate by pressing the key which is arrowed by ms.
- (9) Press the key which is arrowed by CONTINUE to return to the SEQUENTIAL TONES menu.
- (10) Press the key which is arrowed by RETURN to return to the AUDIO TEST display.

To decode a programmed tones sequence in the AUDIO TEST mode, proceed as follows:-

- (1) Select RX TEST [2] and AF GEN [6] . The AUDIO TEST display appears.
- (2) Connect the output of the unit under test to the AF INPUT socket [17] .
- (3) Select TONES [1] . From the TONES menu, select SEQUENTIAL DECODE. The SEQUENTIAL TONES menu appears.

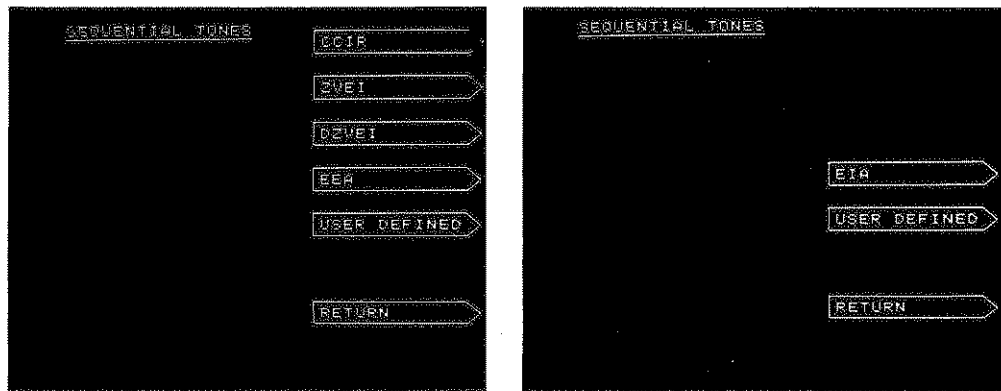

- (4) To return to the AUDIO TEST display at any time, press the key which is arrowed by RETURN.
- (5) From the options on the SEQUENTIAL TONES menu, select the required frequency standard as described under 'Transmitter test' (e.g. CCIR). The appropriate AF SEQUENTIAL TONES menu appears.

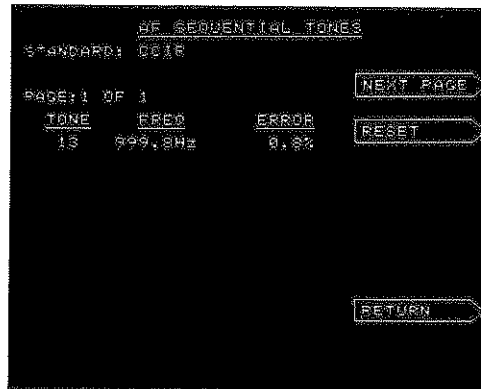

- (6) On the equipment under test, activate the tones which are to be decoded. When triggered, the instrument displays ACTIVE.
- (7) At the end of each measurement, ACTIVE is removed and the decoded tone number, frequency and % error are displayed. If it is within 5% of a standard frequency, the closest tone number is displayed along with the associated error. If the error is worse than 2%, an asterisk is displayed next to the tone number.
- (8) For another test, press the key which is arrowed by RESET. This changes to READY. Otherwise, return to the AUDIO TEST display by pressing RETURN.

To select a user-defined standard, execute (1) to (3) as above and then proceed as for 'Transmitter testing' (5) to (9) and then (10) as above.

If the input level changes, go back to the AUDIO TEST display so that the autoranging is reset.

## REVERTIVE SEQUENTIAL TONES OPERATION

When this is used, the instrument generates a sequential tone sequence for sending to a receiver, the receiver decodes it, its transmitter produces an answering sequence and then the instrument decodes the received signal from the transmitter.

Proceed as follows:-

- (1) Select RX TEST **[2]** . The RECEIVER TEST display appears.
- (2) Connect the unit under test either to RF IN/OUT BNC socket **[14]** or N socket **[15]** . Press SELECT **[11]** until the LED lights above the selected socket.
- (3) Set the RF generator frequency, the RF generator level and the modulation level as previously described in Chap. 3-3.
- (4) Select TONES **[1]** . From the TONES menu, select SEQUENTIAL. The SEQUENTIAL TONES menu appears as under 'Receiver testing'.
- (5) To return to the RECEIVER TEST display at any time, press the key which is arrowed by RETURN.
- (6) From the options on the SEQUENTIAL TONES menu, select REVERTIVE. The RX REVERTIVE SEQUENTIAL TONES menu appears.
- (7) Set the incoming TX FREQ using the FREQ key **[7]** , the DATA keypad **[8]** and a FREQ/LEVEL terminator key **[9]** as for a generator.
- (8) Set the POWER sensitivity to LOW <1 W or HIGH >1 W by pressing the CHANGE key which is alongside.

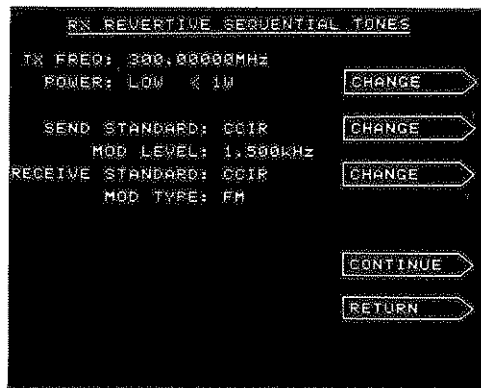

- (9) Set the outgoing SEND STANDARD to CCIR, ZVEI, DZVEI, EIA, EEA or user-defined (UD) by pressing the CHANGE key which is alongside. The user-defined frequencies are as set under 'Sequential tones'.
- (10) Set the incoming RECEIVE STANDARD to CCIR, ZVEI, DZVEI, EIA, EEA or user-defined (UD) by pressing the CHANGE key which is alongside. The user-defined frequencies are as set under 'Sequential tones'.
- (12) Set the incoming MOD TYPE to AM, FM or  $\Phi$ M by pressing the appropriate MOD key **[10]** .

- (13) Press the CONTINUE key. The RX REVERTIVE SEQUENTIAL TONES display appears.

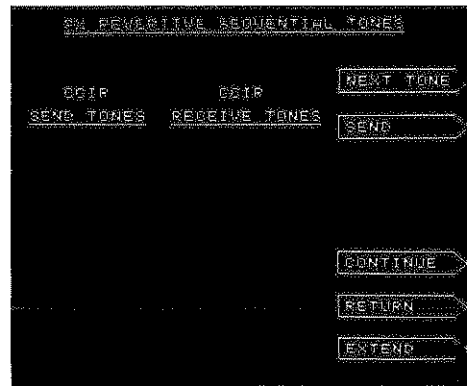

- (14) Define a programmed tones sequence of up to 11 tones as previously described under 'Sequential tones' by using the NEXT TONE key and the keypad [8] or the VARIABLE control [12].
- (15) To generate the tones sequence, press the SEND key.
- (16) To return to the RX REVERTIVE SEQUENTIAL TONES menu, press the CONTINUE key.
- (17) To return to the RECEIVER TEST display, press the RETURN key.

## DTMF (DUAL-TONE MULTI-FREQUENCY) OPERATION

When this is used, each digit is coded into two simultaneous frequencies as follows:-

Hz	1209	1336	1477	1633
697	1	2	3	A
770	4	5	6	B
852	7	8	9	C
941	*	0	#	D

### Transmitter testing

The instrument generates a DTMF sequence for sending to a transmitter, the transmitter produces a modulated RF signal and then the instrument decodes the received signal from the transmitter.

Proceed as follows:-

- (1) Select TX TEST **[4]** . The TRANSMITTER TEST display appears.
- (2) Connect the audio input of the unit under test to the AF GEN OUTPUT socket **[16]** .
- (3) Connect the RF output of the unit under test to either the RF IN/OUT BNC socket **[14]** or N socket **[15]** . Press SELECT **[11]** until the LED lights above the selected socket.
- (4) Key up the transmitter and ensure that the instrument is correctly tuned to the transmitter's frequency.
- (5) Select TONES **[1]** . From the TONES menu, select DTMF. The DTMF GENERATOR AND DECODER display appears.

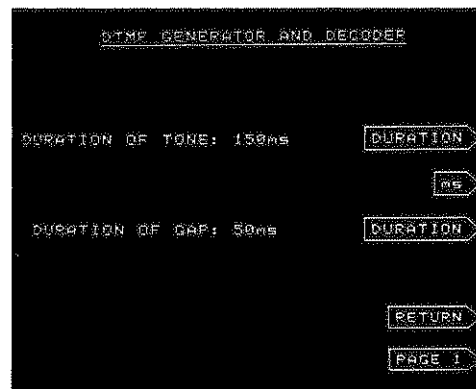
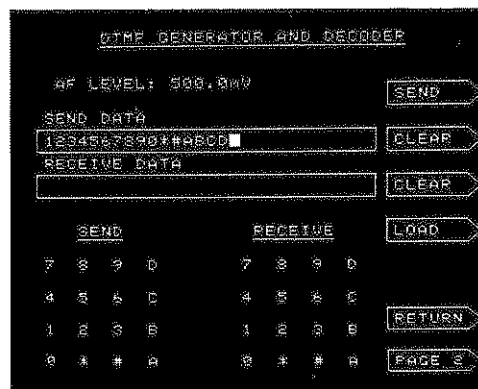

- (6) To return to the TRANSMITTER TEST display at any time, press the key which is arrowed by RETURN.
- (7) Set the AF generator level as described in Chap. 3-2.

- (8) To send single digits, press keys 0 to 9 and adjacent keys as shown on the SEND mimic.
- (9) To enter a sequence of digits in the SEND DATA field, press the CLEAR key which is alongside, press the LOAD key and then press keys 0 to 9 and adjacent keys as shown on the SEND mimic.
- (10) To change one or more digits, turn the VARIABLE control **[12]** to highlight a digit and then press a DATA key **[8]** or the DELETE key **[11]**. To terminate the entry, press the LOAD key again.
- (11) To generate the tones sequence, press the SEND key. The received tones are decoded and shown in the RECEIVE DATA field which scrolls to the left when it is full.
- (12) To clear the RECEIVE DATA field, press the CLEAR key which is alongside.
- (13) To return to the TRANSMITTER TEST display, press the RETURN key.

To select different tones timing, execute (1) to (5) as above and then proceed as follows:-

- (6) Press the key which is arrowed by PAGE 2.
- (7) Set the DURATION OF TONES by pressing the key alongside which is arrowed by DURATION and then entering the duration (in the range 10 to 999) in ms using the keypad **[8]**. Terminate by pressing the key which is arrowed by ms.
- (8) Set the DURATION OF GAP as in (2).
- (9) Press the key which is arrowed by PAGE 1.

## Receiver testing

The instrument generates a DTMF sequence for modulating the RF generator, the receiver produces a demodulated AF signal and then the instrument decodes the received AF signal from the receiver.

Proceed as follows:-

- (1) Select RX TEST **[2]**. The RECEIVER TEST display appears.
- (2) Set the RF frequency and the RF level as described in Chap. 3-3.
- (3) Connect the RF input of the unit under test to either the RF IN/OUT BNC socket **[14]** or N socket **[15]**. Press SELECT **[13]** until the LED lights above the selected socket.
- (4) Connect the audio output of the unit under test to the AF INPUT socket **[17]**.
- (5) Select TONES **[1]**. From the TONES menu, select DTMF. The DTMF GENERATOR AND DECODER display appears.



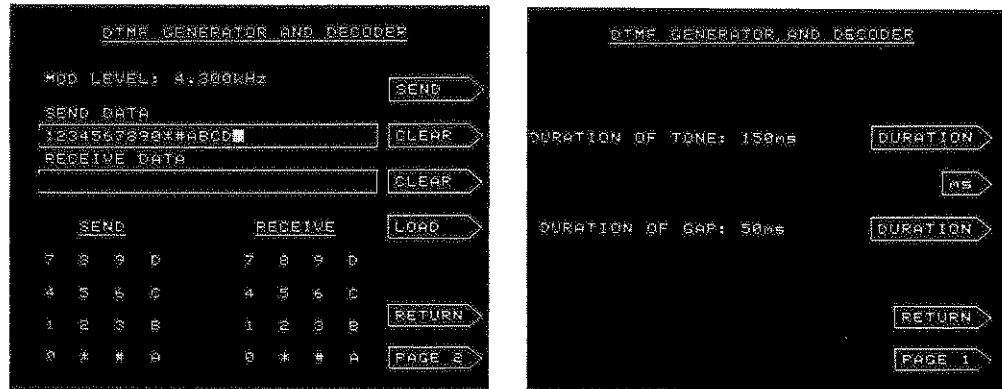

- (6) To return to the RECEIVER TEST display at any time, press the key which is arrowed by RETURN.
- (7) Set the modulation level as described in Chap. 3-3.
- (8) To enter a sequence of digits in the SEND DATA field, press the CLEAR key which is alongside, press the LOAD key and then press keys 0 to 9 and adjacent keys as shown on the SEND mimic.
- (9) To change one or more digits, turn the VARIABLE control [12] to highlight a digit and then press a DATA key [8] or the DELETE key [11]. To terminate the entry, press the LOAD key again.
- (10) To generate the tones sequence, press the SEND key. The received tones are decoded and shown in the RECEIVE DATA field which scrolls to the left when it is full.
- (11) To clear the RECEIVE DATA field, press the CLEAR key which is alongside.
- (12) To return to the RECEIVER TEST display, press the RETURN key.

To select different tones timing, execute (1) to (5) as above and then proceed as follows:-

- (6) Press the key which is arrowed by PAGE 2.
- (7) Set the DURATION OF TONES by pressing the key alongside which is arrowed by DURATION and then entering the duration (in the range 10 to 999) in ms using the keypad [8]. Terminate by pressing the key which is arrowed by ms.
- (8) Set the DURATION OF GAP as in (2).
- (9) Press the key which is arrowed by PAGE 1.

## Duplex testing

This is exactly the same as described under 'Receiver testing' except that RF connections are as described in Chap. 3-4.

## Audio testing

This is exactly the same as described under 'Transmitter testing' except that the AF output of the unit under test is connected to the AF INPUT socket [17].

## DCS (DIGITALLY-CODED SQUELCH) OPERATION

### Transmitter testing

The transmitter under test produces a modulated RF signal and the instrument decodes the received signal from the transmitter.

Proceed as follows:-

- (1) Select TX TEST **[4]** . The TRANSMITTER TEST display appears.
- (2) Connect the RF output of the unit under test to either the RF IN/OUT BNC socket **[14]** or N socket **[15]** . Press SELECT **[13]** until the LED lights above the selected socket.
- (3) Key up the transmitter and ensure that the instrument is correctly tuned to the transmitter's frequency.
- (4) Select TONES **[1]** . From the TONES menu, select DCS. The DCS DECODER display appears.

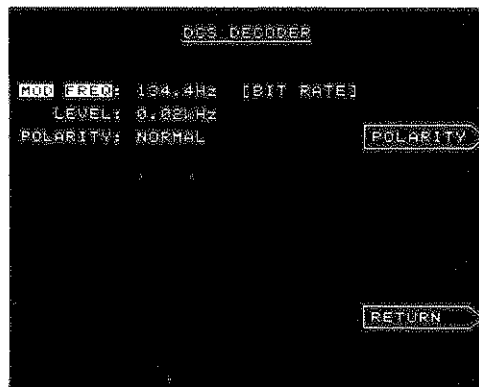

- (5) To return to the TRANSMITTER TEST display at any time, press the key which is arrowed by RETURN.
- (6) Set the modulation frequency (to the received bit rate) by using the keypad **[8]** and the Hz terminator key **[9]** or the VARIABLE control **[12]** . MOD FREQ is permanently selected and highlighted in reverse video. The default value is 134.4 Hz. The measured sub-audio deviation level is displayed.
- (7) Set the bit polarity by using the POLARITY key. NORMAL is for a positive-going 1; INVERTED is for a negative-going 1.
- (8) On the unit under test, trigger the DCS signal. The decoded signal is shown pictorially with all possible synchronizing bits (binary 100 marked SYNC) followed by the relevant possible address codes (9 bits, 3 octal digits). The preferred code is shown in reverse video.

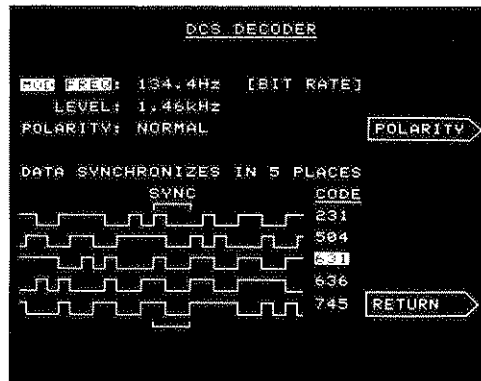

- (9) To return to the TRANSMITTER TEST display, press the RETURN key.

## Receiver testing

The instrument generates a 9-bit address (3 octal digits) followed by the sync bits (binary 100) and by the 11 check bits for modulating the RF generator.

Proceed as follows:-

- (1) Select RX TEST 2. The RECEIVER TEST display appears.
- (2) Set the RF frequency and the RF level as described in Chap. 3-3.
- (3) Connect the RF input of the unit under test to either the RF IN/OUT BNC socket 14 or N socket 15. Press SELECT 13 until the LED lights above the selected socket.
- (5) Select TONES 1. From the TONES menu, select DCS. The DCS GENERATOR display appears.

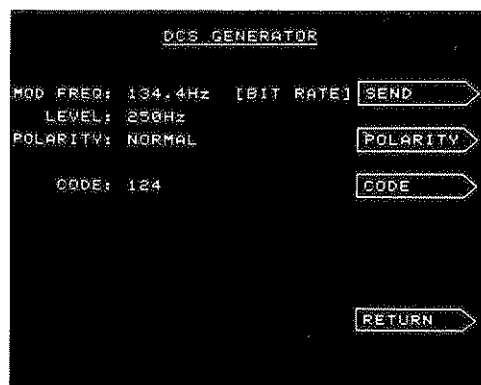

- (6) To return to the RECEIVER TEST display at any time, press the key which is arrowed by RETURN.
- (7) Set the modulation frequency (bit rate) by selecting FREQ 7 and using the keypad 8 and the Hz terminator key 9 or the VARIABLE control 12.

- (8) Set the sub-audible deviation level by selecting LEVEL and using the keypad **[8]** and a terminator key **[9]** or the VARIABLE control **[12]** .
- (9) Set the bit polarity by using the POLARITY key. NORMAL is for a positive-going 1; INVERTED is for a negative-going 1.
- (10) Press the CODE key. This changes to ENTER. Enter the 3-octal-digit (0 to 7) address code by using the keypad **[8]** or the VARIABLE control **[12]** . Press the ENTER key.
- (11) To generate the address, press the SEND key. This changes to STOP. SENDING DATA flashes on the display.
- (12) To stop generation, press the STOP key. Until STOP is pressed, generation continues behind other operations, DCS is shown in reverse video on the RECEIVER TEST and DUPLEX test displays, the second AF generator cannot be reset and pressing TONES causes the DCS GENERATOR display to appear immediately.
- (13) To return to the RECEIVER TEST display, press the RETURN key.

### Duplex testing

This is exactly the same as described under 'Receiver testing' except that the RF connections are as described in Chap. 3-4.

## POCSAG RADIO PAGER TESTING

The instrument produces an RF signal which is modulated by 32-bit code words of the following form:-

No. of bits	Symbol	Purpose
1	M	Message/address
18	A	Address
2	F	Function
10	C	Check
1	P	Parity

Proceed as follows:-

- (1) Select RX TEST [2] or DUPLEX TEST [5]. The RECEIVER TEST display or the DUPLEX test display appears.
- (2) To the RF IN/OUT BNC socket [14], connect the Telescopic Antenna which is available as an optional accessory. See under 'Accessories' in Chap. 1.
- (3) Select TONES [1]. From the TONES menu, select POCSAG. The POCSAG RADIO PAGER TEST display appears.

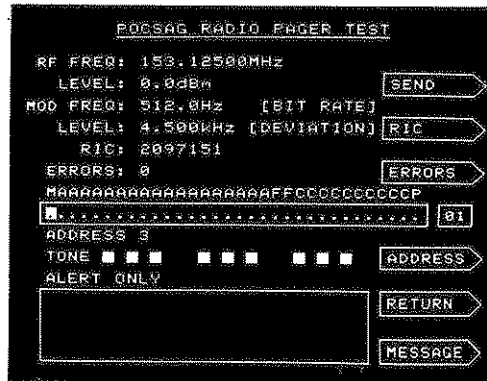
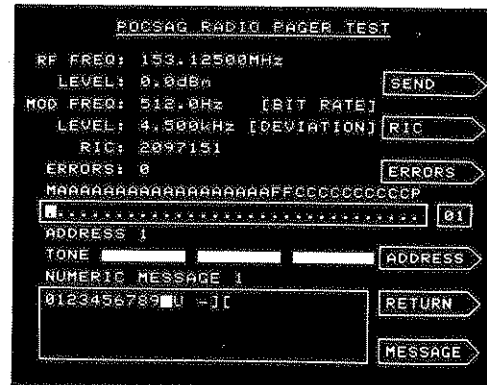
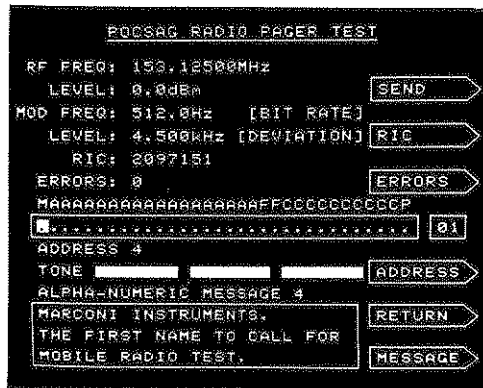

- (4) To return to the RECEIVER TEST display or the DUPLEX test display at any time, press the key which is arrowed by RETURN.
- (5) Set the pager's RF frequency, a suitable RF level, the modulation frequency (bit rate) and the modulation level as described in Chap. 3-3. The modulation level is the deviation of the FSK bits 0 and 1 on each side of the carrier.
- (6) To enter the pager's 7-digit RIC (radio identification code), press the RIC key and use the keypad **[8]**. RIC changes to ENTER (flashing) when the first digit is pressed. To enter the RIC, press the ENTER key which then changes back to RIC. This remains highlighted in reverse video and available for another entry until the key is pressed again.
- (7) To choose one of the four addresses, press the ADDRESS key once or more. The appropriate ringing TONE is displayed pictorially.
- (8) Address 1 has two numeric messages. Addresses 2 and 3 are ALERT ONLY. Address 4 has four alpha-numeric messages. The messages are displayed in the lower box. To select the message, press the MESSAGE key once or more.
- (10) Errors can be created in the address code word. The errors are displayed in the upper box. To create an error or delete an existing error, press the ERRORS key which then changes to CHANGE (flashing). Press the CHANGE key to change the bit which is highlighted in reverse video. Use the VARIABLE control **[12]** to select the highlighted bit. The number of this bit is displayed in the small right-hand box. E is shown for each error. Against ERRORS, the total number of errors is shown. To delete all errors simultaneously, press the ERROR key and then the DELETE key **[11]**.
- (11) To generate the test signal, press the SEND key. SENDING DATA flashes on the display. The pager does not respond until all the address and message code words have been completed.
- (12) To return to the RECEIVER TEST display or the DUPLEX test display, press the RETURN key.

## Chapter 3-7

# HELP KEY OPERATION

	Page
Help key ... ..	3-67
Operating summaries ... ..	3-68
Parameters ... ..	3-69
RF LEVEL selection ... ..	3-70
STORE FUNCTION selection ... ..	3-70
RF COUNTER RESOLUTION selection ... ..	3-70
DEFAULT NOISE READING selection ... ..	3-70
600 $\Omega$ BALANCED AF ACCESSORY selection ... ..	3-70
20 dB ATTENUATOR ACCESSORY selection ... ..	3-71
DEFAULT AF FILTER selection ... ..	3-71
DEFAULT MOD LEVEL setting ... ..	3-71
RX/TX MOD TYPE LOCK selection ... ..	3-71
TONE STANDARD selection ... ..	3-71
RF LEVEL OFFSET setting ... ..	3-71
GPIB MODE selection ... ..	3-71
Self testing ... ..	3-72

**Table**

3-2 Error codes for RF counter to RF generator frequency test ...	3-73
3-3 Error codes for RF power meter to RF generator power test	3-73
3-4 Error codes for modulation frequency and level tests ... ..	3-74

**Fig.**

3-15 HELP ON TESTING operating summaries ... ..	3-69
---	------

## HELP KEY

When the HELP key is pressed, the HELP menu is displayed which enables you to obtain an operating summary, provides a choice of alternative parameters and implements the self-test routines. To return to the operating mode, press the key arrowed by RETURN.

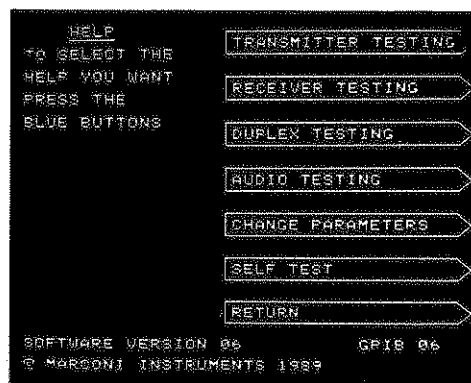

## OPERATING SUMMARIES

You can refer to an operating summary by pressing one of the MODE keys which is arrowed by the following:-

- (a) TRANSMITTER TESTING.
- (b) RECEIVER TESTING.
- (c) DUPLEX TESTING.
- (d) AUDIO TESTING.

The HELP ON TESTING operating summary is then displayed. See Fig. 3-15. This includes information upon key operation (e.g. to select TRANSMITTER TEST, press the TX TEST key). Note that this is for information only and it is necessary to press the MODE key arrowed by RETURN twice (once to return to the HELP menu and once to return to the operating mode) before pressing the designated key.

Where summaries occupy two pages, press the MODE key arrowed by CONTINUE to change from one page to another. Return to the HELP menu by pressing the key arrowed by RETURN.

```

HELP ON TRANSMITTER TESTING
TO SELECT          PRESS
TRANSMITTER TEST  TX TEST
MOD TYPE          FM/AM/PM
DEMOD BANDWIDTH   BANDPASS/LOWPASS
DISTORTION [1kHz] DISTN
RECEIVE TONES     TONES
TX FREQ           TX TEST+FREQ+
                  NUMBERS+TERMINATOR.
AF GEN            AF GEN+[1/2]+[ING]+
                  FREQ/LEVEL+
                  NUMBERS+TERMINATOR.
NOTE
HIGHLIGHTED PARAMETERS CAN RETURN
ALSO BE ADJUSTED USING VARIABLES.
LOWPASS TOGGLES BETWEEN 15kHz AND 300kHz.
SCOPE DISPLAYS DEMOD SIGNAL.

```

### Transmitter testing

```

HELP ON RECEIVER TESTING 1 OF 2
TO SELECT          PRESS
RECEIVER TEST     RX TEST
AF BANDWIDTH      BANDPASS/LOWPASS
DISTORTION [1kHz] DISTN
AF VOLTS IN dBV   DISTN [DISTN]
SEND TONES        TONES
NOTE
DC COUPLING CANNOT BE SELECTED WHEN
READING DISTORTION, SINAD OR S/N.
WHEN DC COUPLED, THE AF VOLTS MORE
READING IS TRUE RMS DC+AC.
dB TOGGLES BETWEEN dBV AND dBV. RETURN
LOWPASS TOGGLES BETWEEN 50kHz AND 300kHz.
SCOPE BANDWIDTH IS FIXED AT 50kHz.

```

```

HELP ON RECEIVER TESTING 2 OF 2
TO ADJUST         PRESS
RF GEN            RF GEN+[ING]+FREQ/LEVEL+
                  NUMBERS+TERMINATOR.
MOD GEN           MOD GEN+[1/2]+[ING]+
                  FREQ/LEVEL+
                  NUMBERS+TERMINATOR.
NOTE
MOD GEN AND MOD GEN 1 BOTH SELECT GEN 1.
TO SELECT GEN 2 PRESS MOD GEN 2.
HIGHLIGHTED PARAMETERS CAN MORE
ALSO BE ADJUSTED USING VARIABLES.
FOR MOD GEN SETTINGS IN MORE RETURN
DETAIL, PRESS TONES-MOD SETUP.

```

### Receiver testing



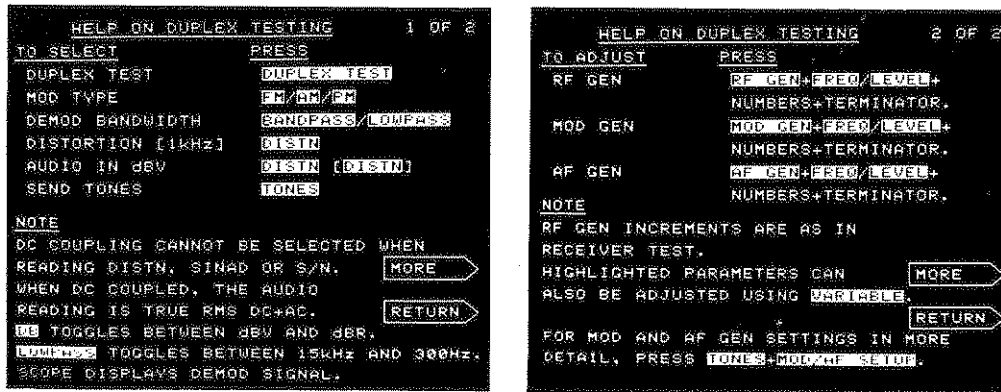

Duplex testing

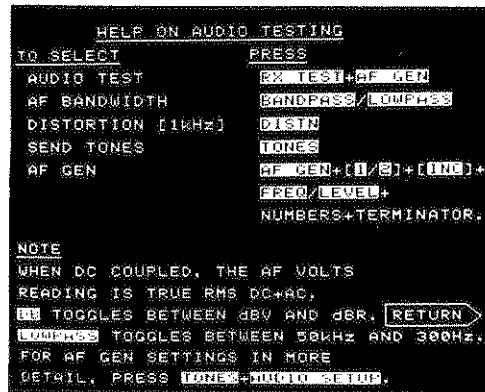

Audio testing

Fig. 3-15 HELP ON TESTING operating summaries

PARAMETERS

Pressing the key arrowed by CHANGE PARAMETERS causes the parameters menu to be displayed. It consists of two pages of options as shown below. The selected state is highlighted in reverse video.

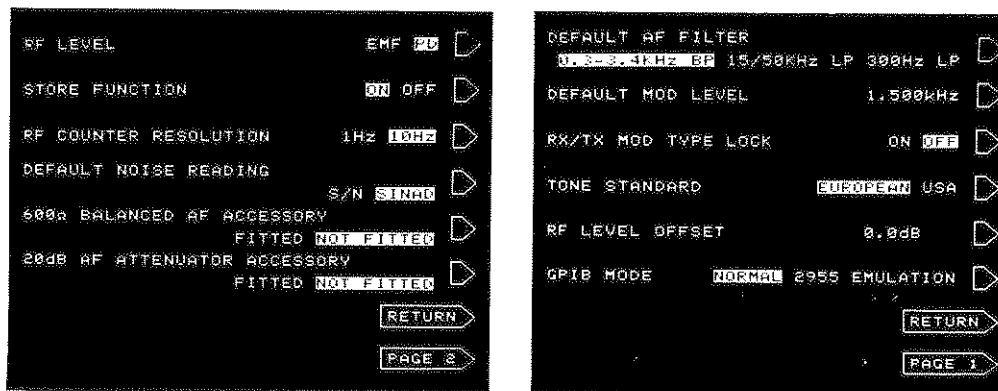

PAGE 1 allows changes to be made under the following options:-

- (a) RF LEVEL.
- (b) STORE FUNCTION.
- (c) RF COUNTER RESOLUTION.
- (d) DEFAULT NOISE READING.
- (e) 600  $\Omega$  BALANCED AF ACCESSORY.
- (f) 20 dB AF ATTENUATOR ACCESSORY.

PAGE 2 allows changes to be made under the following options:-

- (a) DEFAULT AF FILTER.
- (b) DEFAULT MOD LEVEL.
- (c) RX/TX MOD TYPE LOCK.
- (d) TONE STANDARD.
- (e) RF LEVEL OFFSET.
- (f) GPIB MODE.

Pressing PAGE 2 or PAGE 1 selects the other page of the menu; RETURN restores the HELP menu.

### **RF LEVEL selection**

For the level of the RF generator, select either EMF or PD. European practice is to show the output level as PD (loaded) or EMF (unloaded).

### **STORE FUNCTION selection**

To enable or disable the STORE facility, select ON or OFF. OFF prevents existing data being over-written.

### **RF COUNTER RESOLUTION selection**

For frequencies up to 200 MHz, select either 1 Hz or 10 Hz. The resolution is 10 Hz for frequencies above 200 MHz.

### **DEFAULT NOISE READING selection**

When the instrument is switched on, either S/N or SINAD appears in appropriate displays until the SINAD S/N key is used. Select S/N or SINAD.

### **600 $\Omega$ BALANCED AF ACCESSORY selection**

The default audio units can be selected. When the instrument is switched on, either dBm appears (as appropriate when this accessory is fitted) or V appears (as appropriate when this accessory is not fitted). Thereafter, the LEVEL keys can be used. Select either FITTED or NOT FITTED.

## **20 dB ATTENUATOR ACCESSORY selection**

Select either FITTED or NOT FITTED. When FITTED is selected, the displayed AF generator level is decreased by a factor of 10 (20 dB).

When the Attenuator has been selected, A (highlighted in reverse video) appears against the LEVEL of the AF generators(s).

## **DEFAULT AF FILTER selection**

Select the 0.3 to 3.4 kHz bandpass filter, the 15 or 50 kHz lowpass filter or the 300 Hz lowpass filter.

## **DEFAULT MOD LEVEL setting**

Enter a required modulation level.

## **RX/TX MOD TYPE LOCK selection**

For the DUPLEX test mode, the transmitter's type of modulation can be locked to be that of the receiver. Select either ON (for the same type of modulation) or OFF (for separate setting).

## **STONE STANDARD selection**

For sequential tones testing, select either EUROPEAN (CCIR, ZVEI, DZVEI and EEA) or USA (EIA).

## **RF LEVEL OFFSET setting**

When required, enter an offset. This is used to give the appropriate result when an external RF attenuator is fitted. When an offset has been entered, A (highlighted in reverse video) appears against RF levels.

## **GPIB MODE selection**

Select either NORMAL or 2955 EMULATION. 2955 EMULATION is required for use with a Cellular Adapter or when using GPIB software which has been written for the 2955.

## SELF TESTING

On the HELP menu, pressing the key arrowed by SELF TEST causes the SELF TEST display to appear. Press the ALL TESTS key to initiate the complete self-testing procedure.

During each individual test, ACTIVE is displayed. At the end of each of the thirteen individual tests, either PASSED or FAILED appears against the test number. In the case of a failed test, the error code for the failure is shown. For the meaning of the codes, see Table 3-2, Table 3-3 and Table 3-4.

SELF TEST		NEXT TEST
TEST	ERROR CODE	
1.0	PASSED	
1.1	PASSED	
1.2	PASSED	
1.3	PASSED	
1.4	PASSED	
2.0	PASSED	
2.1	PASSED	
2.2	PASSED	
2.3	PASSED	
3.0	PASSED	ALL TESTS
3.1	PASSED	
3.2	PASSED	RETURN
3.3	PASSED	

At any time, the self test can be terminated by pressing the key arrowed by RETURN. At the end of the tests, the instrument waits for RETURN which displays the HELP menu.

### Notes...

- (1) Before implementing the self-testing procedure, remove any leads which are connected to the coaxial connectors to prevent extraneous pick-up affecting the readings.
- (2) In the RF counter to RF generator power test, the difference in the setting and reading levels is due to one-port duplex operation being selected for the test.

The individual tests can be initiated one at a time (e.g. after a failure). Initiate each individual test by repeatedly using the NEXT TEST key.

**TABLE 3-2 ERROR CODES FOR RF COUNTER TO RF GENERATOR  
FREQUENCY TEST**

Error code (hexadecimal)	Test no.	Frequency	Error
10			None (passed)
11	1.0	20 MHz	High (>50 Hz above set frequency)
12	1.0	20 MHz	Low (>50 Hz below set frequency)
13	1.1	111 MHz	High
14	1.1	111 MHz	Low
15	1.2	218 MHz	High
16	1.2	218 MHz	Low
17	1.3	340 MHz	High
18	1.3	340 MHz	Low
19	1.4	480 MHz	High
1A	1.4	480 MHz	Low
1B			Frequency read failure

**TABLE 3-3 ERROR CODES FOR RF POWER METER TO RF GENERATOR  
POWER TEST**

Error code (hexadecimal)	Test no.	Frequency	RF generator setting	Power meter reading	Error
20					None (passed)
21	2.0	300 MHz	0.25 mW	79 mW	Low (>2 dB below set level)
22	2.0	300 MHz	0.25 mW	79 mW	High (>2 dB above set level)
23	2.1	849 MHz	0.25 mW	79 mW	Low
24	2.1	849 MHz	0.25 mW	79 mW	High
25	2.2	20 MHz	0.25 mW	79 mW	Low
26	2.2	20 MHz	0.25 mW	79 mW	High
27	2.3	20 MHz	0.125 mW	40 mW	Low
28	2.3	20 MHz	0.125 mW	40 mW	High

TABLE 3-4 ERROR CODES FOR MODULATION FREQUENCY AND LEVEL TESTS

Error code (hexadecimal)	Test no.	RF frequency	Modulation frequency	Level	Error
30					None (passed)
31	3.0	210 MHz	400 Hz	5 kHz	Gen. 1 frequency (>1 Hz from setting)
33	3.0	210 MHz	400 Hz	5 kHz	Gen. 1 level low (>10% below setting)
34	3.0	210 MHz	400 Hz	5 kHz	Gen. 1 level high (>10% above setting)
32	3.1	210 MHz	1 kHz	5 kHz	Gen. 2 frequency
35	3.1	210 MHz	1 kHz	5 kHz	Gen. 2 level low
36	3.1	210 MHz	1 kHz	5 kHz	Gen. 2 level high
37	3.2	210 MHz	1 kHz	50%	Gen. 2 level low
38	3.2	210 MHz	1 kHz	50%	Gen. 2 level high
39	3.3	210 MHz	1 kHz	5 rad	Gen. 2 level low
3A	3.3	210 MHz	1 kHz	5 rad	Gen. 2 level high

## Chapter 3-8

# GPIB OPERATION

	Page
GPIB functions ... .. .	3-75
GPIB address ... .. .	3-75
Display ... .. .	3-76
GPIB commands ... .. .	3-76

**Fig.**  
 3-16 Switches on the GPIB interface unit set to the talk listen mode  
 and to address 6 (2 + 4) ... .. . 3-76

### GPIB FUNCTIONS

The GPIB (general purpose interface bus) Interface Unit allows the instrument to be coupled to a controller. Further information on the general features and applications of the GPIB system can be obtained from the separate GPIB Manual which is offered as an optional accessory. See under 'Accessories' in Chap. 1.

### GPIB ADDRESS

The instrument's address can be selected on the switch bank which is positioned on the GPIB Interface Unit on the rear of the instrument. See Fig. 3-16.

For the talk and listen mode, set the TALK ONLY switch 6 to OPEN (0). Set the ADDRESS 2 and 4 switches (4 and 3) to on (not OPEN) to give an address of 6 (or set any other address in the range 0 to 30 decimal).

For the talk only mode, set the TALK ONLY switch 6 to not OPEN (1). The positions of ADDRESS 1, 2 and 4 (5, 4 and 3) are irrelevant. Set the ADDRESS 16 and 8 switches (1 and 2) as required as follows:-

Switch	Function
ADDRESS 16 (1)    ADDRESS 8 (2)	
0                    0	Upper and lower case, <CR> suppressed
0                    1	Upper and lower case <CR> not suppressed
1                    0	Upper case only, <CR> suppressed
1                    1	Upper case only, <CR> not suppressed

When the HELP key is pressed, the HELP menu is displayed. This shows the GPIB address at the bottom of the screen. In the talk only mode, T is shown after the listen address.

**Note...**

If any switch position is changed, switch off the instrument and then switch it on again so that the instrument reads the new setting(s).

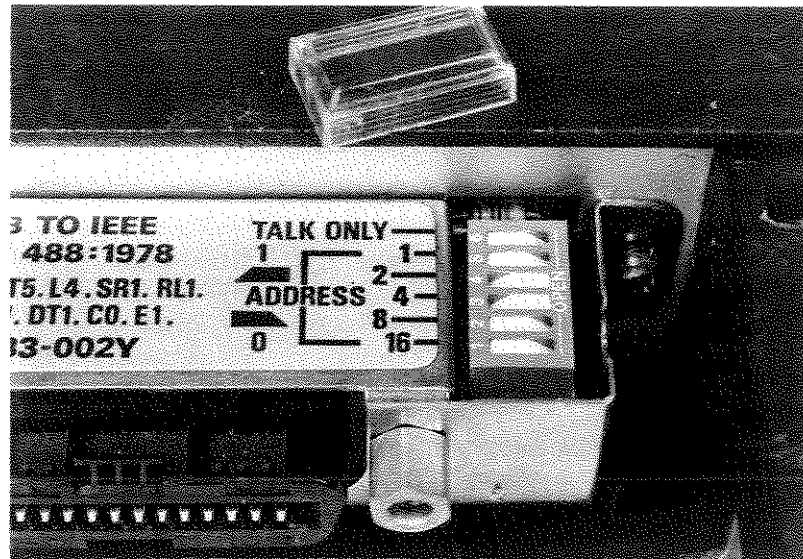

Fig. 3-16 Switches on the GPIB Interface Unit set to the talk and listen mode and to address 6 (2 + 4)

## DISPLAY

During GPIB operation, the following are shown on the screen:-

- (a) REM. Once the instrument has received a remote enable and has been addressed, it enters the remote state. REM appears in reverse video in the bottom right-hand corner of the screen.
- (b) ADR. When it is in the remote condition and the instrument is addressed to either talk or listen, ADR appears in reverse video in the bottom right-hand corner of the screen.
- (c) SRQ. When it is in the remote condition and enabled, a service request is raised. SRQ appears in reverse video in the bottom right-hand corner of the screen.
- (d) LCL. When it is in the remote condition and LLO (Local Lockout) has not been sent, LCL (LoCaL) appears next to the HELP key. Pressing HELP then causes the instrument to enter the GTL (Go To Local) condition. The GTL condition is not the same as the power-on condition since the REN (Remote Enable) line from the controller is still active.

## GPIB COMMANDS

See the Programming Manual.



## Chapter 3-9

# PRINTER OPERATION

	<b>Page</b>
Introduction ... ..	3-77
Power supplies ... ..	3-77
GPIB cable ... ..	3-77
Operation ... ..	3-77

<b>Fig.</b>	
3-17 Example of the printout for a transmitter test ... ..	3-78

## INTRODUCTION

Any listen only printer can be used with the 2955A. A printer designed for use with the instrument is offered as an optional accessory. See under 'Accessories' in Chap. 1.

## POWER SUPPLIES

When operating with the 2955A, the MI printer uses the ACCESSORY socket for its power supply. For stand-alone operation, it requires a supply of 12 V at 2 A peak. Any other printer may need its own power supply. However, the ACCESSORY socket (pin 2) can be used for +12 V at approximately 100 mA continuous.

## GPIB CABLE

The GPIB cable is connected between the printer and the GPIB interface unit which is fitted at the rear of the 2955A. For cables with IEC connectors, an IEEE to IEC adapter can be used for conversion purposes. For a suitable adapter which is offered as an optional accessory, see under 'Accessories' in Chap. 1.

## OPERATION

To use a ticket printer for printing out measurement results, proceed as follows:-

- (1) Make the power supply and GPIB cable connections as given above.
- (2) On the 2955A's GPIB Interface Unit, set the TALK ONLY switch 6 to on (not OPEN). Set switches 1 and 2 as required. See under 'GPIB address'. In the TALK ONLY mode, switches 3, 4 and 5 are inoperative.
- (3) Switch off the 2955A and then switch it on again to enable the instrument to read the new switch settings.
- (4) Press the HOLD DISPLAY key. HOLD OFF is displayed against the SCOPE/BAR key and PRT appears against the HELP key.

- (5) Press the key arrowed by PRT. This starts the printer and results in a printout of the major settings and readings shown in the top half of the display. See the example in Fig. 3-17. Once printing has started, there is no way to abort it.
- (6) When using the ACCESSORY socket for power, the screen may be affected (e.g. the sides may be drawn in) due to power drain, especially when printing rows of dots. This is unimportant and does not affect measurement results since these are already frozen.

```

TRANSMITTER TEST
-----

SETTINGS
-----

AF FREQ:1.0000kHz
LEVEL:12.0mV
FILTER:0.3-3.4kHz

READINGS
-----

TX FREQ:439.99951MHz
POWER:54mW
MOD FREQ:1.000 kHz
LEVEL:2.64kHz
DISTN:4.3%

MODEL:.....
SER NO:.....
DATE:.....
    
```

*Fig. 3-17 Example of the printout for a transmitter test*

For further information, refer to the Instruction Manual for the printer.

## Chapter 3-10

# TRANSMITTER MONITORING (2955R ONLY)

Controls and connectors	...	...	...	...	...	...	...	...	...	Page
Operation	...	...	...	...	...	...	...	...	...	3-79
	...	...	...	...	...	...	...	...	...	3-81

Fig. 3-18 Transmitter monitoring controls and connectors ... 3-79

### CONTROLS AND CONNECTORS

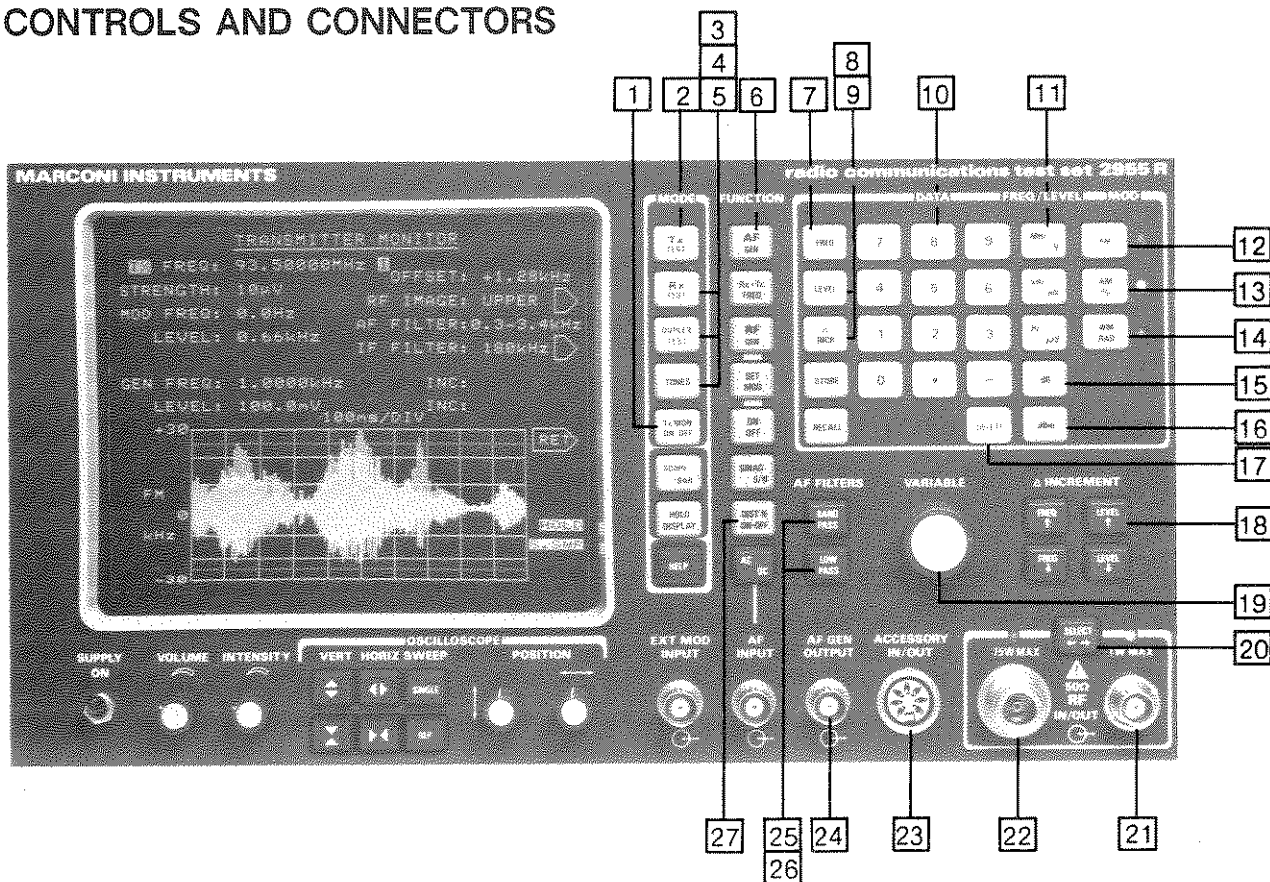

Fig. 3-18 Transmitter monitoring controls and connectors

- 1 **TX MON ON-OFF key.** Enables and disables TRANSMITTER MONITOR testing with the off-air receiver. Returns to the previous mode when disabled.
- 2 **TX TEST key.** Used as a soft key to return to TX after selecting AF GEN [6]. TX is shown in reverse video unless AF GEN [6] has been pressed.
- 3 **RX TEST key.** Used as a soft key to select UPPER or LOWER for the RF IMAGE as shown alongside on the screen. Since the image rejection is 0 dB, an incoming signal at the RF image frequency produces the same IF as the wanted source. The use of this key changes the local oscillator frequency so that it is 21.4 MHz above (UPPER) or below (LOWER) the wanted frequency. The key is ineffective below 21.8 MHz and at or above 978.6 MHz.

- 4 **DUPLEX TEST key.** Used as a soft key to select the 12 or 180 kHz IF FILTER as shown alongside on the screen.
- 5 **TONES key.** Causes the TONES menu to be displayed. See under 'Transmitter testing' in Chap. 3-6.
- 6 **AF GEN key.** See under 'AF generators' in Chap. 3-2. Press TX TEST 2 to return to TX.
- 7 **FREQ key.** Precedes a keypad 10 entry so that the entered data is recognized as a frequency. TX FREQ or GEN FREQ is shown in reverse video.
- 8 **LEVEL key.** Precedes a keypad 10 entry so that the entered data is recognized as a level. GEN LEVEL is shown in reverse video.
- 9 **Δ INCR key.** Follows a FREQ 7 or LEVEL 8 entry so that the entered data is recognized as an increment or decrement. TX INCR, GEN FREQ INC or GEN LEVEL INC is shown in reverse video. After returning to TX FREQ setting, I is shown in reverse video until the increment entry is cancelled by entering zero or an AF GEN frequency increment.
- 10 **DATA keypad.** For data entry using numerals 0 to 9 and decimal point.
- 11 **FREQ/LEVEL keys.** For defining units of frequency. One of these terminates the data entry. Any one of these selects the STRENGTH reading in  $\mu\text{V}$  or mV.
- 12 **MOD FM key and LED.** When the key is pressed, the LED lights to show that FM demodulation has been selected.
- 13 **MOD AM % key and LED.** When the key is pressed, the LED lights to show that AM demodulation has been selected.
- 14 **MOD  $\Phi$ M RAD key and LED.** When the key is pressed, the LED lights to show that  $\Phi$ M (FM with de-emphasis) demodulation has been selected.
- 15 **dB key.** Selects a STRENGTH reading in dB $\mu$ V.
- 16 **dBm key.** Selects a STRENGTH reading in dBm (50  $\Omega$ ).
- 17 **DELETE key.** Deletes a preceding digit or decimal point which has been entered on the keypad 10.
- 18 **Δ INCREMENT keys.** Increase and decrease the frequency and the level by the increments which have been set using 9.
- 19 **VARIABLE control.** Analogue control which provides an alternative to the DATA keypad 10 for entering data.
- 20 **SELECT key and LEDs.** For selecting RF IN/OUT BNC or N socket 21 or 22. LED lights above the socket selected.
- 21 **RF IN/OUT BNC socket.** For the Telescopic Antenna or another antenna or for a very low-power transmitter or probe. Automatically protected against excessive power. Impedance 50  $\Omega$ .

- [22] RF IN/OUT N socket.** For higher level inputs. A temperature sensor detects excessive power being applied. Impedance 50  $\Omega$ .
- [23] ACCESSORY socket.** DIN 7-pin connector for an external psophometric (telephone weighting) CCITT or C-message filter option.
- [24] AF GEN OUTPUT socket.** BNC socket. For output for modulating the transmitter.
- [25] BAND PASS key.** Selects a 0.3 to 3.4 kHz band-pass filter or an EXTERNAL filter which is connected to the ACCESSORY socket [23].
- [26] LOW PASS key.** Selects a 300 Hz or a 15 kHz low-pass filter.
- [27] DIST'N ON-OFF key.** Causes the distortion reading and bar chart to appear. Distortion is measured using a modulation frequency of 1 kHz. This can be supplied from the AF GEN OUTPUT socket [24].

## OPERATION

Proceed as follows:-

- (1) Press the TX MON ON-OFF key [1]. The TRANSMITTER MONITOR display appears. To return to the previous mode at any time, press [1] again.
- (2) Connect the Telescopic Antenna (a supplied accessory) to the RF IN/OUT BNC socket [21] or another antenna to the RF IN/OUT BNC socket [21] or N socket [22].
- (3) Press SELECT [20] until the LED lights above the appropriate RF IN/OUT socket [21] or [22].
- (4) Set the TX FREQ, the frequency at which the transmitter is expected to transmit, by using the FREQ key [7], the DATA keypad [10] and a FREQ/LEVEL key [11]. On the screen, OFFSET is the difference between this frequency and the transmitter's measured frequency.
- (5) When required, set a frequency increment by using the W INCR key [9] and the FREQ  $\uparrow$  and FREQ  $\downarrow$  keys [8]. When an increment has been entered, I is shown in reverse video alongside the transmitter frequency.
- (6) Select the transmitter's type of modulation by pressing the MOD FM key [12], the MOD AM % key [13] or the MOD  $\Phi$ M key [14].
- (7) Using RX TEST [3] as a soft key, select the RF IMAGE as UPPER or LOWER.
- (8) Using DUPLEX TEST [4] as a soft key, select the IF FILTER as 12 or 180 kHz.
- (9) Select the unit of the STRENGTH reading by pressing one of the FREQ/LEVEL keys [11] for  $\mu$ V or mV, the dB key [15] for dB $\mu$ V or the dBm key [16] for dBm (50  $\Omega$ ).

- (10) When required for modulation purposes, set the AF generator frequency and level. See under 'AF generator' in Chap. 3-2.
- (11) When an AF filter is required, press BAND PASS **[25]** or LOW PASS **[26]** .
- (12) Use DIST'N ON-OFF **[26]** to enable distortion measurement.

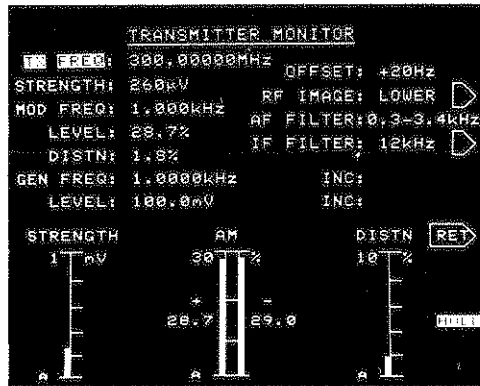

## Chapter 4

# BRIEF TECHNICAL DESCRIPTION

	Page
Introduction ... ..	4-1
Signal generator ... ..	4-1
AF voltmeter ... ..	4-2
AF generator ... ..	4-2
RF power meter ... ..	4-3
Modulation meter ... ..	4-4
Distortion meter ... ..	4-6
<b>Fig.</b>	
4-1 Signal generator block diagram ... ..	4-2
4-2 AF voltmeter block diagram ... ..	4-2
4-3 AF generator block diagram ... ..	4-3
4-4 RF power meter block diagram ... ..	4-3
4-5 Modulation meter block diagram ... ..	4-4
4-6 Distortion meter block diagram ... ..	4-6

## INTRODUCTION

This equipment is a combination of several instruments, most of which have some shared circuitry. Since the constructions of the counters and the oscilloscope are not relevant to the explanation of the operation of the instrument, and the signalling codes tests are mainly implemented in software, these are not described in this chapter. The RF signal generator, AF voltmeter, AF generator, RF power meter, modulation meter and distortion and SINAD meters are each described in outline with accompanying block diagrams.

## RF SIGNAL GENERATOR

The signal generator simplified block diagram is shown in Fig. 4-1. Three voltage controlled oscillators phase locked to a 10 MHz reference operate with a synthesizer to provide outputs in the range 400 kHz to 1000 MHz. The generator may be amplitude, frequency or phase modulated, the modulating signal being derived from the AF generator. An audio signal applied to the EXT MOD INPUT socket adds to the internal modulating signal to provide a two tone modulation capability. Generator output frequency may be set to a maximum resolution of 50 Hz while the output level may be controlled in 0.1 dB steps. The HELP key is used to calibrate the output level in EMF or PD. Maximum output is 400 mV to the BNC socket or 40 mV, with the 20 dB pad, to the N socket. Since these sockets are also used for RF power measurements, the signal generator is reverse power protected at the BNC socket.

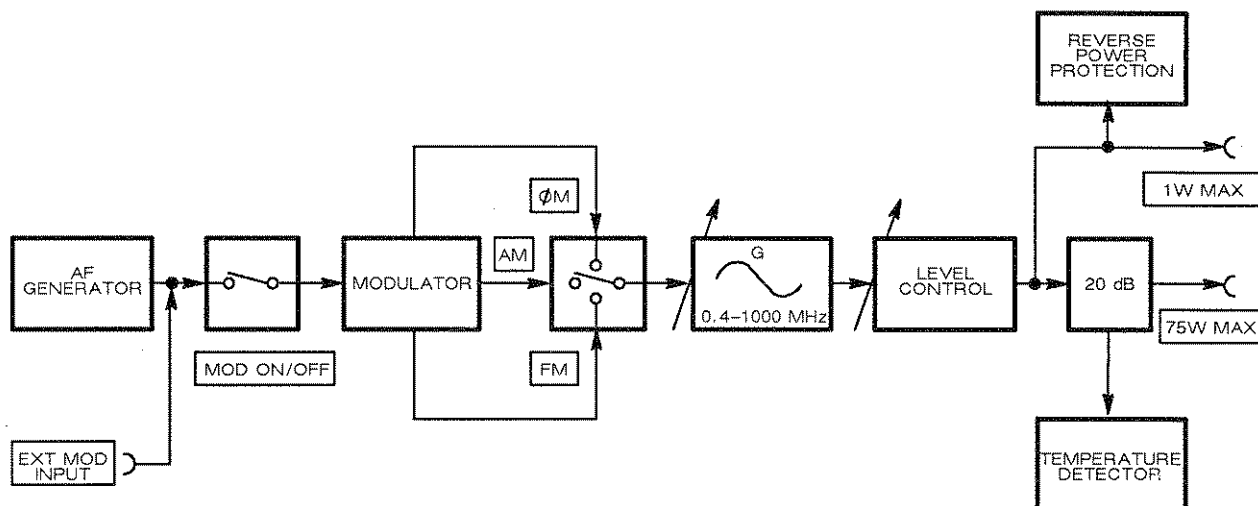

Fig. 4-1 RF Signal generator block diagram

## AF VOLTMETER

The AF voltmeter measures an input in the ranges 20 Hz to 50 kHz and 0 to 100 V applied to the AF INPUT socket. The AC/DC key is used to switch in and out a capacitor so as to measure AF volts with or without the DC component. Following processor-operated level control circuits and an output to the AF counter, the signal is fed through a switch-selected 0.3 to 3.4 kHz band-pass or a 300 Hz or 50 kHz low-pass filter. Output from an RMS detector is analogue-to-digital converted before the measured level is displayed. The simplified block diagram is shown in Fig. 4-2.

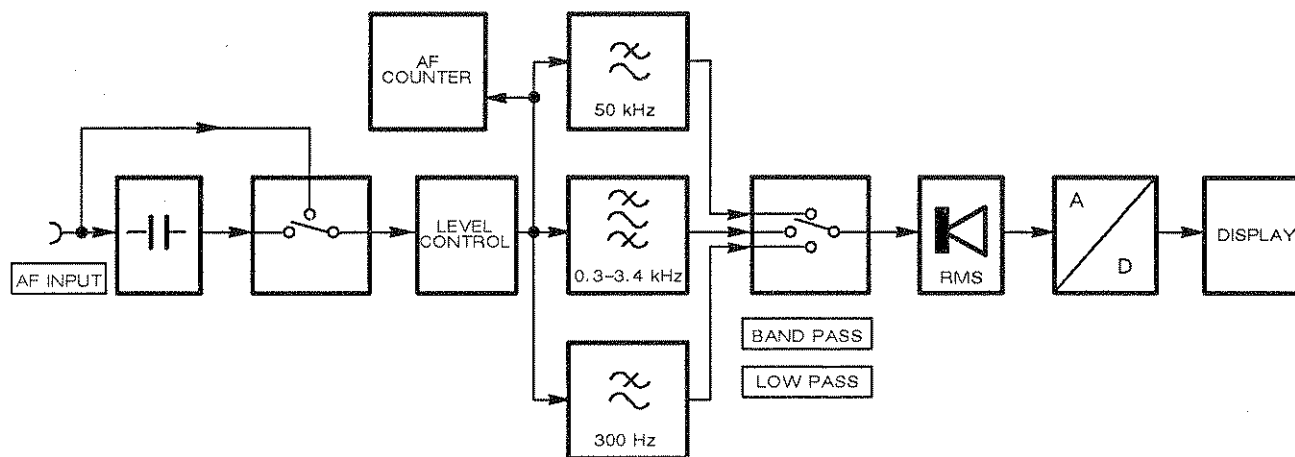

Fig. 4-2 AF voltmeter block diagram

## AF GENERATOR

The AF generator simplified block diagram is shown in Fig. 4-3. When enabled by the AF GEN key and 1 or 2 as appropriate, the AF generator produces variable frequencies in the range 10 Hz to 20 kHz as well as a dedicated LF square wave used for digital signalling. Maximum frequency accuracy is 0.01 Hz. Output may be controlled to a maximum EMF level of 4 V at the AF GEN OUTPUT socket. The AF generator also provides the signal used to amplitude, frequency or phase modulate the internal signal generator.



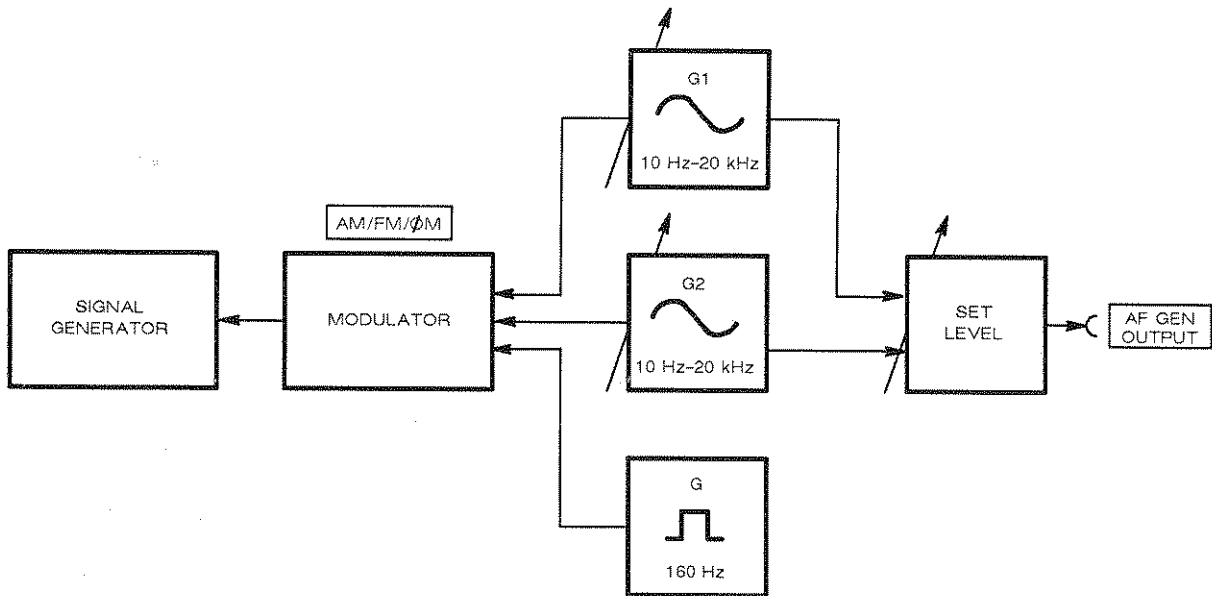

Fig. 4-3 AF generator block diagram

**RF POWER METER**

The RF power meter simplified block diagram is shown in Fig. 4-4. Due to the 20 dB pad, continuous RF power of 75 W (or 150 W for a short period) may be applied to the N socket. Any overload detected by a heat sensor results in both visual and audible warnings to the user. Reduced accuracy measurements at low power from the BNC socket may be made using the SELECT key. Following processor operated level control circuits an output is taken to the RF counter as well as to a sampling gate. The gate is switched at a sub-harmonic of the input frequency to produce a 110 kHz IF. Output from an RMS detector is analogue-to-digital converted and the RF power level displayed.

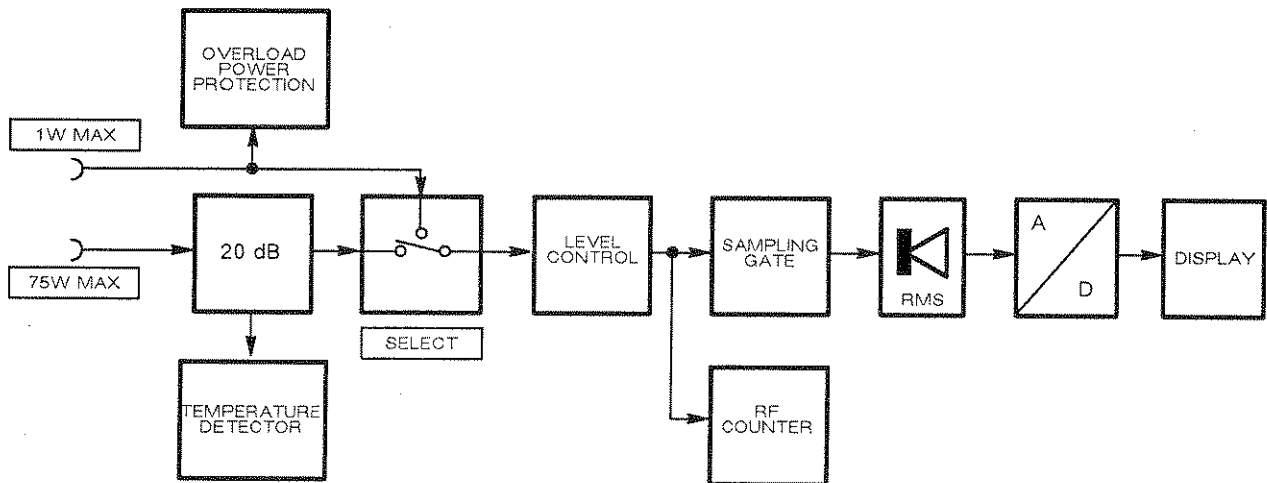

Fig. 4-4 RF power meter block diagram

## MODULATION METER

The modulation meter simplified block diagram is shown in Fig. 4-5. An input from the transmitter connected to the N socket is passed by the SELECT switch to the processor operated level control circuit. Outputs are taken to the RF counter and to a sampling gate. The gate is switched at a sub-harmonic of the input frequency to produce a 110 kHz IF which takes one of two paths. When AM demodulation is selected, the IF is first divided down and then detected. When FM or  $\Phi$ M demodulation is selected, the signal is frequency to voltage converted which results in a voltage varying at the modulation rate. For  $\Phi$ M the signal additionally passes through a de-emphasis stage. Switch selectable 0.3 to 3.4 kHz band-pass and 300 Hz or 15 kHz low-pass filters follow. At this point, outputs are taken to the AF counter, to the rear panel DE MOD OUT socket and to an internal loudspeaker used for audio monitoring. In the main signal path, processor operated peak detectors follow which measure the modulation peaks and troughs. The signal is finally analogue-to-digital converted and the modulation is displayed.

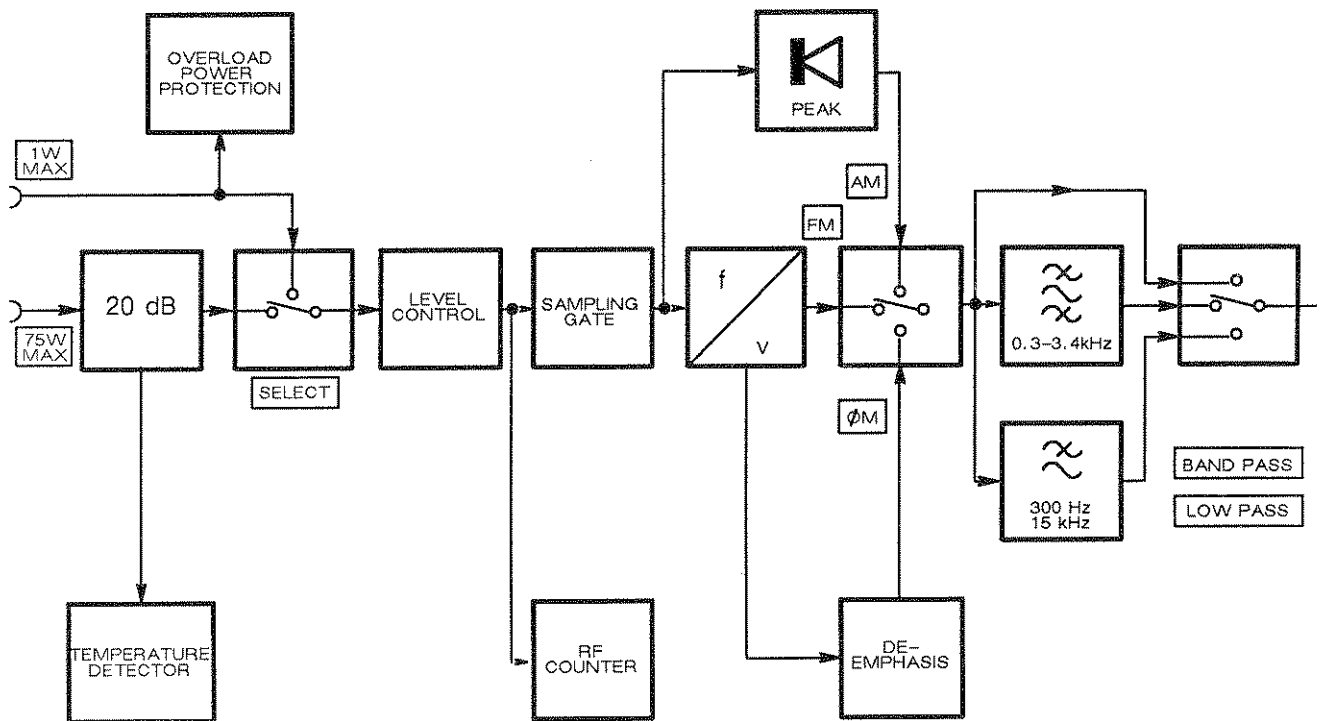
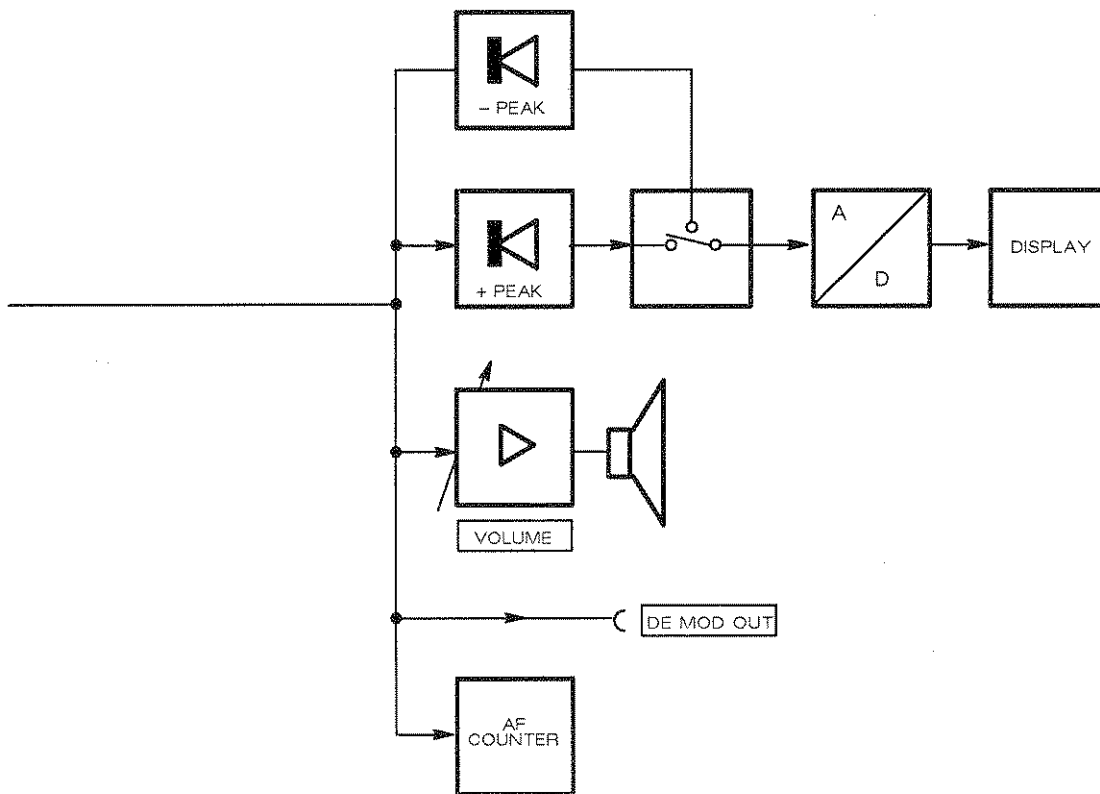

Fig. 4-5 Modulation meter block diagram



## DISTORTION METER

The distortion meter simplified block diagram is shown in Fig. 4-6. For a TX measurement, the modulated input from the transmitter connected to the BNC socket for low power or to the N socket for high power is passed by the SELECT switch to the processor operated level control circuit. Outputs are taken to the RF counter and to a sampling gate. The gate is switched at a sub-harmonic of the input frequency to produce a 110 kHz IF which takes one of two paths. When AM demodulation is selected, the IF is first divided down and then detected. When FM or  $\Phi$ M demodulation is selected, the signal is frequency to voltage converted which results in a voltage varying at the modulation rate. For  $\Phi$ M the signal additionally passes through a de-emphasis stage.

If an RX measurement is being made, the receiver's audio output at a frequency of 1 kHz is connected to the AF INPUT socket. This is fed through a capacitor by the AC key and then the level is adjusted by processor operated level control circuits prior to the signal being selected for measurement.

The signal is fed through a 300 Hz to 3.4 kHz band-pass filter and then to a switched 1 kHz band-stop filter. When this is switched in it removes the 1 kHz fundamental frequency and so leaves the harmonic distortion for measurement. An RMS detector follows whose output is analogue-to-digital converted and then the distortion factor or SINAD is calculated and displayed.

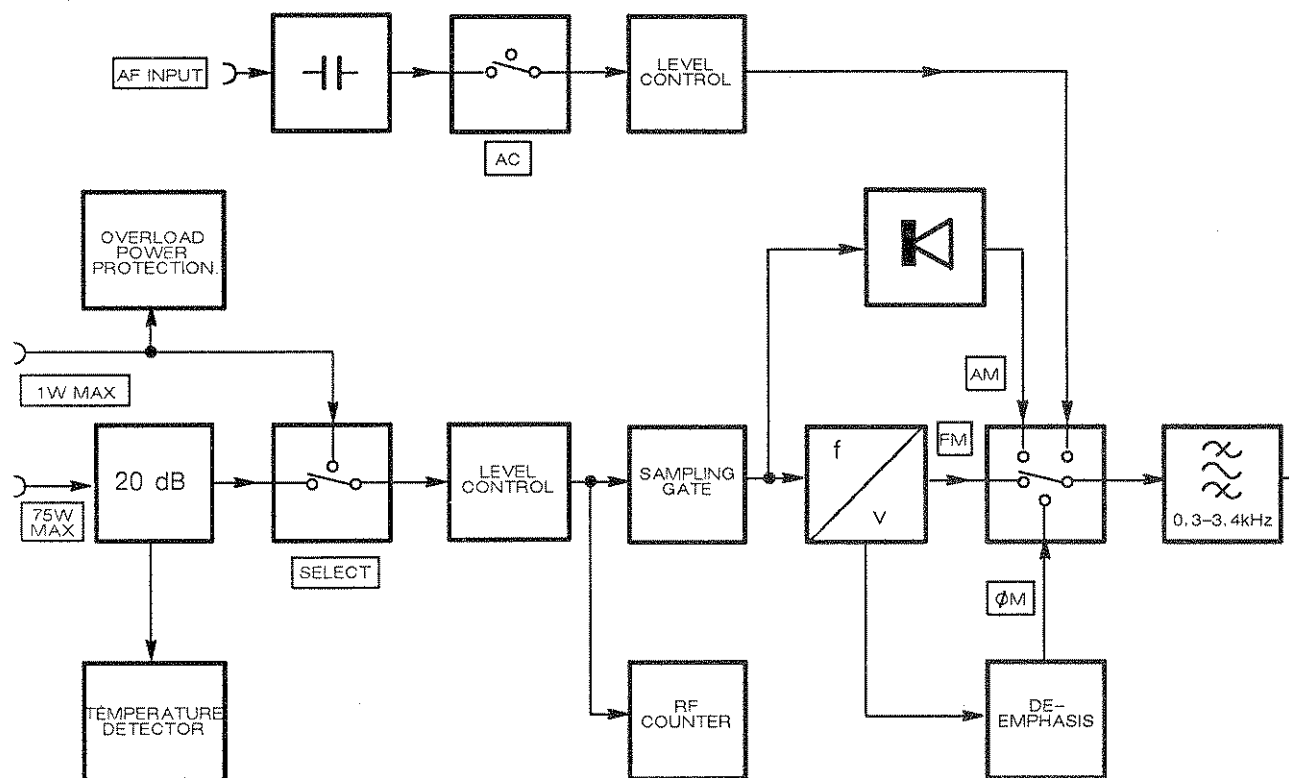

Fig. 4-6 Distortion meter block diagram

The distortion-type measurements are:-

$$S/N = 20 \log \frac{\text{Signal}}{\text{Noise}} \quad (\text{dB})$$

where noise is measured in a 0.3 to 3.4 kHz bandwidth and understood to include all components apart from signal and harmonic distortion.

$$\text{Distortion factor} = \frac{\text{Distortion} + \text{noise}}{\text{Signal} + \text{distortion} + \text{noise}} \times 100\%$$

$$\text{SINAD} = 20 \log \frac{1}{\text{Distortion factor}} \quad (\text{dB})$$

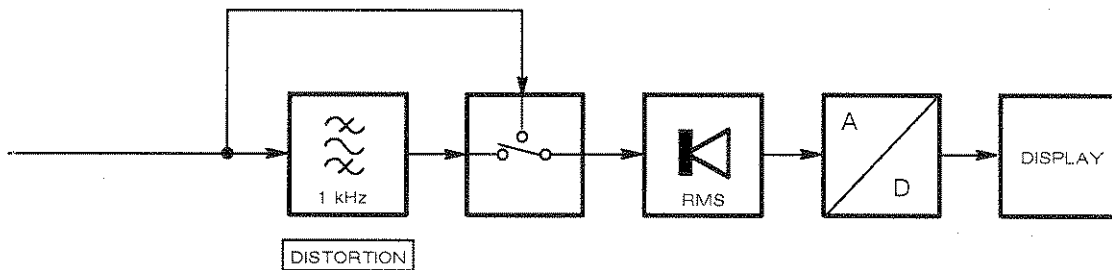

Blank page.

## Chapter 5

# ACCEPTANCE TESTING

## Contents

	Page
General ... ..	5-3
Testing ... ..	5-3
Oscilloscope ... ..	5-3
AF level DC offset ... ..	5-4
AF level gain ... ..	5-4
Demodulated FM gain ... ..	5-5
Demodulated AM gain ... ..	5-6
Modulation meter ... ..	5-7
Demodulation distortion ... ..	5-7
AM monitor ... ..	5-9
FM monitor ... ..	5-11
Input sensitivity ... ..	5-12
Voltmeter ... ..	5-13
DC and AF level meter accuracy ... ..	5-13
AF level meter frequency response ... ..	5-15
RF frequency meter ... ..	5-15
Accuracy ... ..	5-16
Input sensitivity ... ..	5-17
AF frequency meter ... ..	5-18
Accuracy and sensitivity ... ..	5-18
AF generator ... ..	5-19
Output level ... ..	5-20
Distortion ... ..	5-21
Frequency accuracy... ..	5-22
DC offset, residual noise and waveform shapes ... ..	5-22
DTMF encoder and decoder ... ..	5-24
Distortion/SINAD meter ... ..	5-25
Distortion accuracy ... ..	5-25
RF power meter... ..	5-25
Measurement accuracy ... ..	5-26
Selcall ... ..	5-27
Tones ... ..	5-27
RF generator ... ..	5-28
Output level ... ..	5-29
RF generator frequency accuracy ... ..	5-30
AM internal accuracy... ..	5-31
FM internal accuracy ... ..	5-33
AM and FM distortion ... ..	5-33
External AM and FM... ..	5-35
RF leakage ... ..	5-36
FM on CW ... ..	5-37
Carrier harmonics, sub-harmonics and spurious signals ... ..	5-38

## Contents (contd.)

Table	Page
5-1 AF level gain – oscilloscope ... ..	5-5
5-2 Demodulated FM gain – oscilloscope ... ..	5-6
5-3 Demodulated AM gain – oscilloscope ... ..	5-6
<b>Fig.</b>	
Test equipment connections for performance checks:-	
5-1 Oscilloscope AF level gain ... ..	5-4
5-2 Oscilloscope demodulated FM gain... ..	5-5
5-3 Modulation meter demodulation distortion ... ..	5-8
5-4 Modulation meter AM and FM monitor accuracy ... ..	5-9
5-5 Modulation meter AM and FM ... ..	5-10
5-6 Modulation meter input sensitivity ... ..	5-13
5-7 Voltmeter DC and AF level accuracy ... ..	5-14
5-8 Voltmeter frequency response ... ..	5-15
5-9 RF frequency meter accuracy ... ..	5-16
5-10 RF frequency meter input sensitivity ... ..	5-17
5-11 AF frequency meter accuracy and sensitivity ... ..	5-19
5-12 AF generator output level accuracy... ..	5-20
5-13 AF generator distortion ... ..	5-21
5-14 AF generator frequency accuracy ... ..	5-22
5-15 AF generator DC offset ... ..	5-23
5-16 AF generator residual noise ... ..	5-23
5-17 RF power meter measurement accuracy ... ..	5-27
5-18 Selcall tones ... ..	5-28
5-19 RF generator output level ... ..	5-29
5-20 RF generator RF accuracy ... ..	5-31
5-21 RF generator AM and FM accuracy ... ..	5-32
5-22 RF generator AM and FM distortion ... ..	5-34
5-23 RF generator external AM and FM... ..	5-35
5-24 RF generator RF leakage ... ..	5-36
5-25 RF generator FM on CW ... ..	5-37
5-26 RF generator harmonics, sub-harmonics and spurious signals ... ..	5-38



## GENERAL

Integrated circuits and semiconductor devices are used throughout this instrument and, although these have inherent long term reliability and mechanical ruggedness, they are susceptible to damage by overloading, reversed polarity and excessive heat or radiation. Avoid hazards such as prolonged soldering, strong RF fields or other forms of radiation and the use of insulation testers.

In case of difficulties which cannot be resolved with the aid of this book, please contact our Service Division at the address given inside the rear cover, or your nearest Marconi Instruments representative. Always quote the type and serial number found on the data plate at the rear of the instrument.

## TESTING

Test procedures described in this chapter may be simplified and of restricted range compared with the comprehensive factory test facilities which are necessary to demonstrate complete compliance with the specifications.

Performance limits quoted are for guidance and should not be taken as guaranteed performance specifications unless they are also quoted under 'Performance data' in Chap. 1.

When verifying that the instrument meets the stated performance limits, always make allowance for the uncertainty of the test equipment used.

## OSCILLOSCOPE

The oscilloscope checks comprise AF level DC offset, AF level gain, and demodulated FM and AM gain.

### Specification

This section checks that the instrument performs to the following specification:-

DC to 50 kHz (3 Hz on AC)  $\pm 5\%$  accuracy  
FM deviation  $\pm 10\%$  accuracy  
AM depth  $\pm 10\%$  accuracy

## Test gear

The following test gear is required to check the above specification:-

Description	Minimum spec.	Example
AC/DC Calibrator	Accuracy 1.5% DC	Rotek 3950
Signal Generator	100 MHz, AM/FM Level 7 dBm	Marconi 2019A
Modulation meter	AM/FM 100 MHz Accuracy >3%	Marconi 2305
Power splitter	6 dB, 100 MHz	HP 11667A

## Checking AF level DC offset

Proceed as follows:-

- (1) On the UUT select RX and SCOPE, DC coupled. Short out the AF INPUT socket.
- (2) Use the oscilloscope vertical POSITION control to bring the trace onto the centre of the graticule.
- (3) Scan through the vertical scale ranges and check that the trace does not move more than 1/4 division between ranges.

## Checking AF level gain

Proceed as follows:-

- (1) Set the UUT to RX, SCOPE, DC coupled, 50 kHz LOW PASS filter distortion/SINAD/SN off.
- (2) Use the vertical POSITION control to move the trace to the bottom dotted graticule line.
- (3) Connect the equipment as shown in Fig. 5-1.



Fig. 5-1 Test equipment connections for oscilloscope AF level gain

- (4) Set the oscilloscope to 2 V/div. Set the calibrator to output DC and adjust the level until the oscilloscope trace appears on the top dotted graticule line. Check that the calibrator output is within 9.5 to 10.5 V.
- (5) Repeat step (4) above for the remaining oscilloscope ranges and calibrator limits shown in Table 5-1.

TABLE 5-1 AF LEVEL GAIN - OSCILLOSCOPE

Scope range	Nominal DC Volts	Calibrator limits
2 V/div	10 V	9.5 -10.5 V
1 V/div	5 V	4.75 -5.25 V
500 mV/div	2.5 V	2.375 -2.625 V
50 mV/div	0.25 V	0.2375-0.2625 V

### Checking demodulated FM gain

Proceed as follows :-

- (1) Connect the equipment as shown in Fig. 5-2.
- (2) Set the UUT to TX, FM, SCOPE, 0.3 to 3.4 kHz BAND PASS filter, BNC input socket.

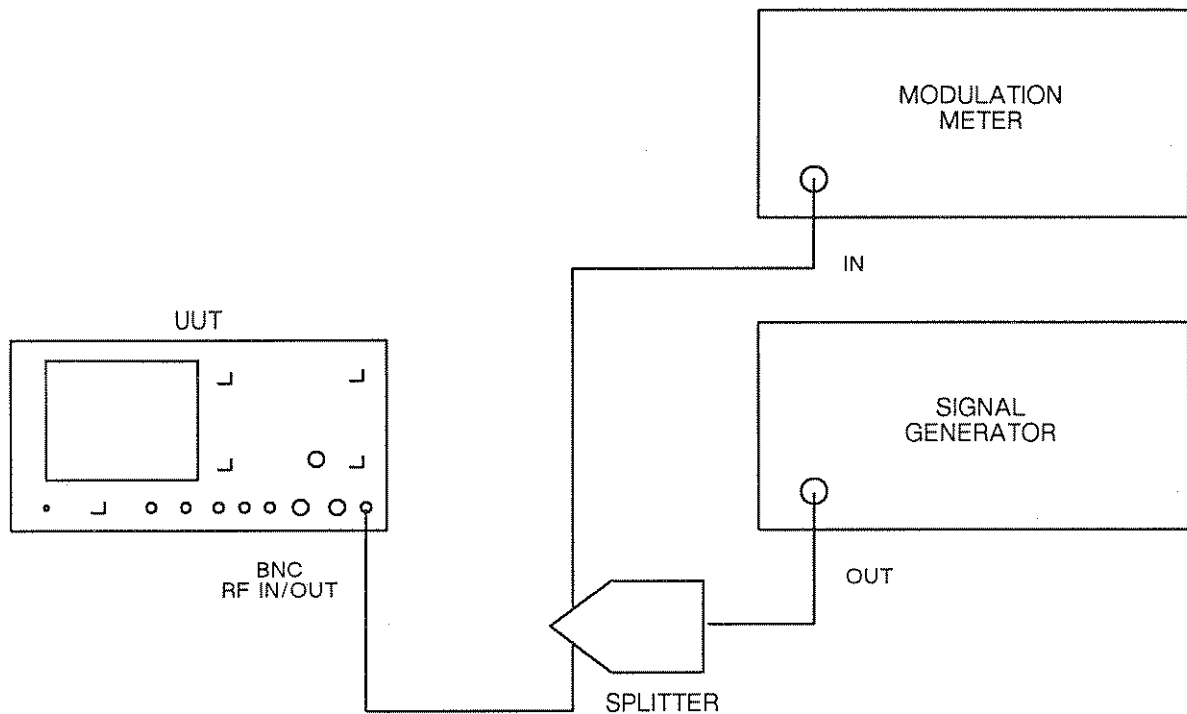

Fig. 5-2 Test equipment connections for oscilloscope demodulated FM gain

- (3) Set the signal generator to carrier frequency 100 MHz, level 7 dBm, FM, 1 kHz internal modulation rate.

- (4) Set the modulation meter to monitor FM, (pk-pk)/2, in a 0.3 to 3.4 kHz bandwidth.
- (5) Set the UUT oscilloscope range to  $\pm 30$  kHz deviation. Adjust the signal generator FM deviation until the FM deviation on the oscilloscope is shown as 20 kHz. Check on the modulation meter that the deviation limits are within 18.0 to 22.0 kHz.
- (6) Repeat step (5) above for the remaining oscilloscope ranges and deviation limits shown in Table 5-2.

TABLE 5-2 DEMODULATED FM GAIN - OSCILLOSCOPE

Scope range $\pm$ deviation	FM deviation on scope	Modulation meter limit
30 kHz	20 kHz	18.0 - 22.0 kHz
15 kHz	10 kHz	9.0 - 11.0 kHz
6 kHz	4 kHz	3.6 - 4.4 kHz
3 kHz	2 kHz	1.8 - 2.2 kHz
1.5 kHz	1 kHz	0.9 - 1.1 kHz

### Checking demodulated AM gain

Proceed as follows:-

- (1) Connect the equipment as shown in Fig. 5-2.
- (2) Set the UUT to TX, AM, SCOPE, 0.3 to 3.4 kHz BAND PASS filter, BNC input socket.
- (3) Set the signal generator to carrier frequency 100 MHz, level 7 dBm, AM, 1 kHz internal modulation rate.
- (4) Set the modulation meter to monitor AM, (pk-pk)/2, in a 0.3 to 3.4 kHz bandwidth.
- (5) Set the UUT oscilloscope range to 20%/div. Adjust the signal generator depth until the waveform on the oscilloscope is shown as 80%. Check on the modulation meter that the depth limits are within 72 to 88%.
- (6) Repeat step (5) above for the remaining oscilloscope ranges and modulation depths shown in Table 5-3.

TABLE 5-3 DEMODULATED AM GAIN - OSCILLOSCOPE

Scope range (% AM/div)	AM depth on scope	Modulation meter limits
20	80%	72 - 88%
10	40%	36 - 44%
5	20%	18 - 22%

## MODULATION METER

The modulation meter checks comprise demodulation distortion, AM and FM monitor accuracy, AM and FM bar chart and scope, and input sensitivity.

### Demodulation distortion specification

This section checks that the instrument performs to the following specification:-

At 30% AM and 1 kHz modulation frequency (in a 0.3 to 3.4 kHz bandwidth).

<2% : 21 MHz carrier and above.

<5% : Up to 21 MHz and above.

<1.5% distortion at 5 kHz deviation and 1 kHz modulation frequency (in a 0.3 to 3.4 kHz bandwidth).

### Demodulation distortion test gear

The following test gear is required to check the above specification:-

Description	Minimum spec.	Example
Signal generator	1.5 - 1000 MHz, FM & AM	2019A
Distortion meter	0.2% distortion accuracy at 1 kHz.	TF 2331A or HP 8903B

### Checking demodulation distortion

Proceed as follows but note that the distortion of the modulated signal being applied will affect the demodulated distortion and therefore should not be more than 0.5%:-

- (1) Connect the equipment as shown in Fig. 5-3.

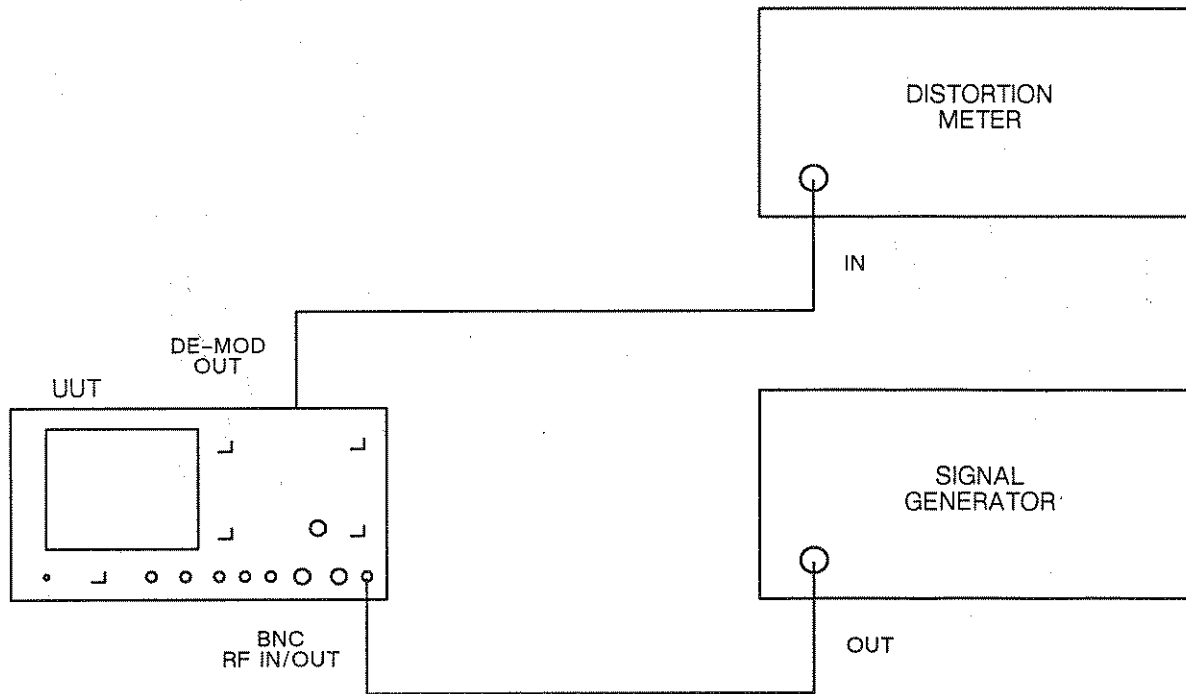

Fig. 5-3 Test equipment connections for modulation meter demodulation distortion performance checks

- (2) Set the UUT to TX, AM, 0.3 to 3.4 kHz BAND PASS filter, BNC input socket.
- (3) Set the signal generator to carrier frequency 100 MHz, level 0 dBm, 30% AM, 1 kHz internal modulation rate.
- (4) Tune in the distortion meter and check that the distortion indicated is <2%.
- (5) Set the signal generator to 12 MHz. Tune in the distortion meter and check that the distortion indicated is <5%.
- (6) Change the UUT modulation to FM.
- (7) Change the signal generator modulation to 5 kHz FM, modulation rate 1 kHz, carrier frequency 100 MHz.
- (8) Tune in the distortion meter and check that the distortion indicated is <1.5%.

### AM monitor accuracy specification

This section checks that the instrument performs to the following specification:-

- $\pm 5\%$  of reading  $\pm 1$  digit at 1 kHz.
- $\pm 8.5\%$  of reading  $\pm 1$  digit (50 Hz-10 kHz).

## AM monitor accuracy test gear

The following test gear is required to check the above specification:-

Description	Minimum spec.	Example
Signal generator	1.4-400 MHz, AM capability ext. mod. 50 Hz-10 kHz, 0-90%. RF level 13 dBm.	Marconi 2019A
Modulation meter	1.5-400 MHz. AM accuracy 1%.	Marconi 2305
LF synthesizer	50 Hz-10 kHz. 1 V RMS level.	HP 3325A or B
Power splitter	6 dB splitter. 50 $\Omega$ , 1.5-400 MHz.	HP 11667A

## Checking AM monitor accuracy

Proceed as follows:-

- (1) Connect the equipment as shown in Fig. 5-4.

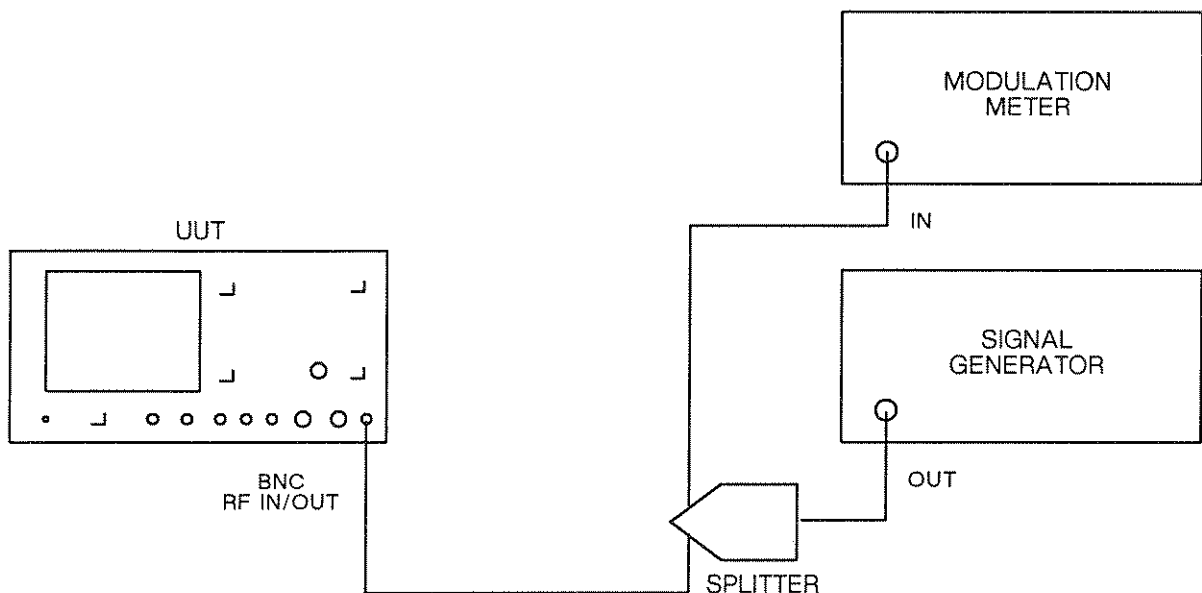

Fig. 5-4 Test equipment connections for modulation meter AM and FM monitor accuracy

- (2) Set the UUT to TX, AM, 0.3 to 3.4 kHz BAND PASS filter, BNC input socket.
- (3) Set the signal generator to carrier frequency 100 MHz, level 7 dBm, 80% AM, 1 kHz internal modulation rate.
- (4) Set the modulation meter to monitor AM in a 0.3 to 3.4 kHz bandwidth.

- (5) Check that the AM level indicated on the UUT display is within  $\pm 5\%$  of reading  $\pm 1$  digit of modulation depth indicated on the modulation meter. Check that the AM bar chart indicates the AM being applied.
- (6) Repeat the above for modulation depths from 0 to 90% and carrier frequencies between 1.5 and 100 MHz.
- (7) Repeat for modulation depths from 0 to 80% and carrier frequencies between 1.5 and 400 MHz.
- (8) Connect an LF generator to the signal generator as shown in Fig. 5-5.

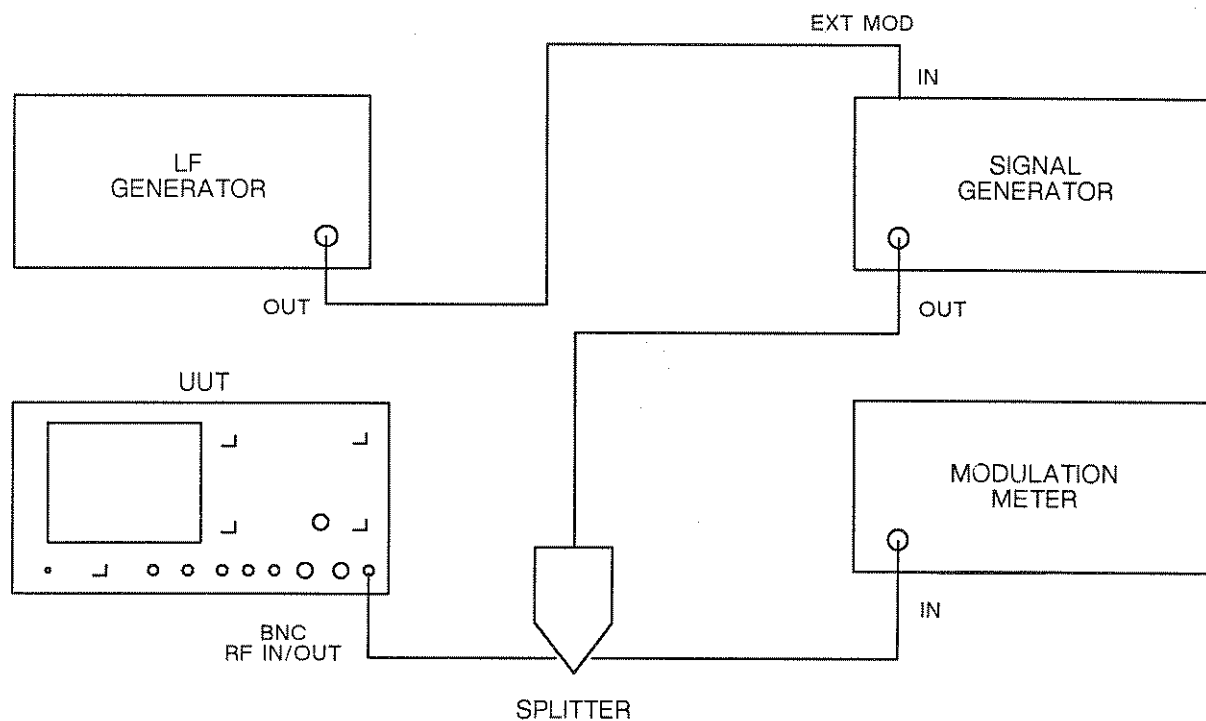

Fig. 5-5 Test equipment connections for modulation meter AM and FM

- (9) Set the UUT to TX, AM, 15 kHz LOW PASS filter, BNC input socket.
- (10) Set the signal generator to carrier frequency 100 MHz, level 7 dBm, 80% external AM at a 10 kHz modulation rate (from the LF generator).
- (11) Set the modulation meter to monitor AM in a 30 Hz to 50 kHz bandwidth.
- (12) Set the synthesized LF generator to give a 10 kHz sine wave. Adjust the level to suit the external modulation input of the signal generator.
- (13) Check that the AM level indicated on the UUT display is within  $\pm 8.5\%$  of reading  $\pm 1$  digit of modulation depth indicated on the modulation meter.
- (14) Repeat the above for modulation rates between 50 Hz and 10 kHz. Ensure that the correct filters are selected on both the UUT and the modulation meter according to the modulation rate being used.



## FM monitor accuracy specification

This section checks that the instrument performs to the following specification:-

$\pm 5\% \pm 1$  digit at 1 kHz.  
 $\pm 6.5\% \pm 1$  over range 50 Hz-10 kHz.

## FM monitor accuracy test gear

The following test gear is required to check the above specification:-

Description	Minimum spec.	Example
Signal generator	1.5-1000 MHz, level 13 dBm. FM 0-25 kHz deviation. FM ext. mod. 50 Hz-10 kHz.	Marconi 2019A
Modulation meter	1.5-1000 MHz. FM accuracy 1%.	Marconi 2305
LF synthesizer	50 Hz-10 kHz. 1 V RMS level.	HP 3325A or B
Power splitter	6 dB splitter. 50 $\Omega$ , 1.5-1000 MHz	HP 11667A

## Checking FM monitor accuracy

Proceed as follows:-

- (1) Connect the equipment as shown in Fig. 5-5.
- (2) Set the UUT to TX, FM, 0.3 to 3.4 kHz BAND PASS filter, distortion/SINAD/SN off, BNC input socket.
- (3) Set the signal generator to carrier frequency 500 MHz, level 13 dBm, 25 kHz FM, 1 kHz internal modulation rate.
- (4) Set the modulation meter to monitor FM in a 0.3 to 3.4 kHz bandwidth.
- (5) Check that the FM level indicated on the UUT display is within  $\pm 5\%$  of reading  $\pm 1$  digit of modulation deviation indicated on the modulation meter. Check that the FM bar chart indicates the FM being applied.
- (6) Repeat the above for random carrier frequencies from 1.5 to 1000 MHz and random deviation between 0 and 25 kHz.
- (7) Set the UUT to TX, FM, 15 kHz LOW PASS filter, BNC input socket.
- (8) Set the signal generator to carrier frequency 500 MHz, level 13 dBm, 25 kHz external FM at 10 kHz modulation (from the LF generator).
- (9) Set the modulation meter to monitor FM in a 30 Hz to 50 kHz bandwidth.
- (10) Set the synthesized LF generator to give a 10 kHz sinewave. Adjust the level to suit the external modulation input of the signal generator.

- (11) Check that the modulation level indicated on the UUT display is within  $\pm 6.5\%$  of the modulation indicated on the modulation meter. Ensure that the correct filters are selected on both the UUT and the modulation meter according to the modulation rate being used.

### Input sensitivity specification

This section checks that the instrument performs to the following specification:-

N socket sensitivity 5 mW.  
In one-port duplex mode, sensitivity is reduced to 20 mW.

### Input sensitivity test gear

The following test gear is required to check the above specification:-

Description	Minimum spec.	Example
Signal generator	Synthesized freq. 1.5-1000 MHz. 1 MHz standard output. Level 13 dBm, FM	Marconi 2019A
Power meter & sensor	1.5-1000 MHz. -30 to +20 dBm.	Marconi 6960A + Sensor 6912

### Checking input sensitivity

Proceed as follows:-

- (1) Set the UUT to TX, FM, 0.3 to 3.4 kHz BAND PASS filter, N input socket.
- (2) Set the signal generator to carrier frequency 400 MHz, modulation 10 kHz FM, modulation rate 1 kHz.
- (3) Connect the power meter to the signal generator output and adjust the RF level to give 5 mW indication on the power meter.
- (4) Connect the signal generator to the UUT N input socket and check that the UUT modulation meter reads 10 kHz FM deviation.
- (5) Set the UUT to one-port duplex mode and repeat the above checks with the signal generator output set to 20 mW.

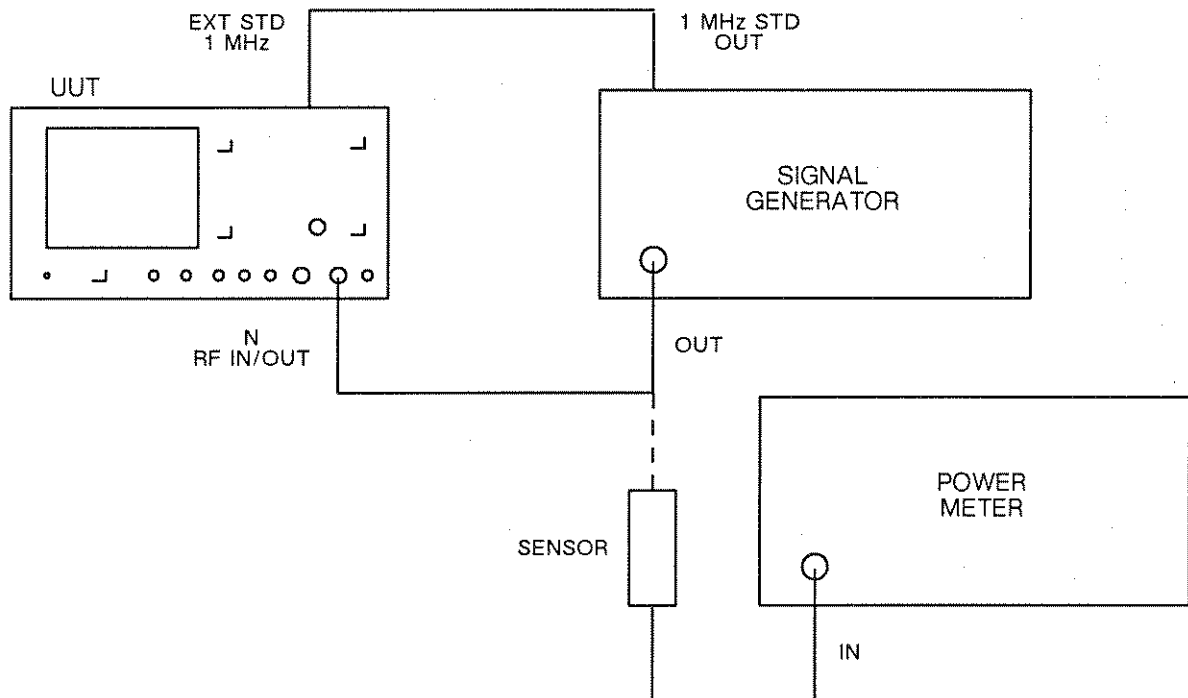

Fig. 5-6 Test equipment connections for modulation meter input sensitivity

## VOLTMETER

The voltmeter checks comprise DC and AF level meter accuracy, and AF level meter frequency response.

### DC and AF level meter accuracy specification

This section checks that the instrument performs to the following specification:-

$$\pm 3\% \text{ of reading } \pm 3 \text{ mV } \pm 1 \text{ digit}$$

### DC and AF level meter accuracy test gear

The following test gear is required to check the above specification:-

Description	Minimum spec.	Example
AC/DC calibrator	DC 0-100 V, AC 1 kHz. Level accuracy better than 0.05%.	Rotek 3950

### Checking DC and AF level meter accuracy

Proceed as follows:-

- (1) Connect the equipment as shown in Fig. 5-7.

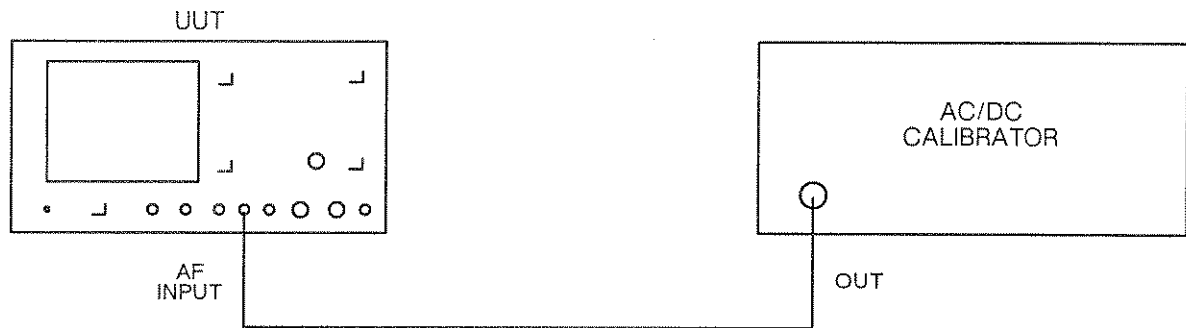

Fig. 5-7 Test equipment connections for voltmeter DC and AF level accuracy

- (2) Set the UUT to audio test, distortion off, 50 kHz LOW PASS filter, DC coupled.
- (3) Set the calibrator to give 1.000 V DC
- (4) Check that the reading on the AF voltmeter indicates the voltage set on the calibrator  $\pm 3\%$  of reading  $\pm 3$  mV  $\pm 1$  digit.
- (5) Repeat for random DC levels up to 100 V.
- (6) Check the operation of the bar chart and oscilloscope.
- (7) Set the UUT to AC coupled.
- (8) Set the calibrator to give 1.000 V AC at 1 kHz.
- (9) Check that the reading on the AF voltmeter indicates the voltage set on the calibrator  $\pm 3\%$  of reading  $\pm 3$  mV  $\pm 1$  digit.
- (10) Repeat at 1 kHz for random levels up to 100 V.

### AF level meter frequency response specification

This section checks that the instrument performs to the following specification:-

$\pm 3\%$  of reading  $\pm 3$  mV  $\pm 1$  digit

### AF level meter frequency response test gear

The following test gear is required to check the above specification:- LF synthesizer

Description	Minimum spec.	Example
LF synthesizer	50 Hz - 20 kHz. Level 2 V RMS	HP 3325A or B R & S SPN
RMS DVM	50 Hz-20 kHz. Accuracy better than 0.02%.	Datron 1065A
50 $\Omega$ termination	50 $\Omega$ $\pm 1\%$ , 1/2 W.	Suhner

## Checking AF level meter frequency response

Proceed as follows:-

- (1) Connect the equipment as shown in Fig. 5-8.

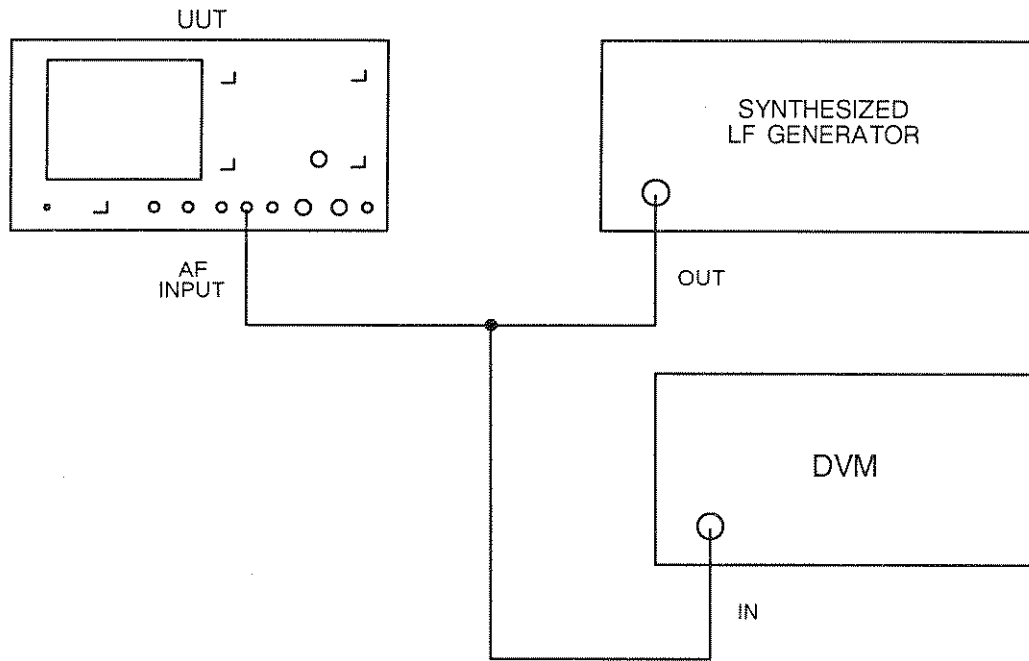

Fig. 5-8 Test equipment connections for voltmeter frequency response

- (2) Set the UUT to audio test, distortion off, 50 kHz LOW PASS filter, AC coupled.
- (3) Set the synthesized LF generator to give a 1 kHz sinewave at 1 V RMS into 50  $\Omega$ .
- (4) Set the DVM to monitor AC, RMS.
- (5) Check that the reading on the AF voltmeter is within  $\pm 3\%$  of reading  $\pm 3$  mV  $\pm 1$  digit of reading indicated on the DVM.
- (6) Repeat the above for LF generator frequencies between 50 Hz and 20 kHz.

## RF FREQUENCY METER

The RF frequency meter checks comprise accuracy and input sensitivity.

### Accuracy specification

This section checks that the instrument performs to the following specification:-

Accuracy: As internal standard  $\pm 1$  digit

## Accuracy test gear

The following test gear is required to check the above specification:-

Description	Minimum spec.	Example
Signal generator	Synthesized freq. 1.5-1000 MHz. 1 MHz standard output.	Marconi 2019A

## Checking accuracy

Note that the following method checks the RF frequency meter (internal counters and dividers) is working correctly. However, overall accuracy depends upon the correct setting of the internal 10 MHz standard (see under 'Adjustments' in the board checks for AC1). Proceed as follows:-

- (1) Connect the equipment as shown in Fig. 5-9.

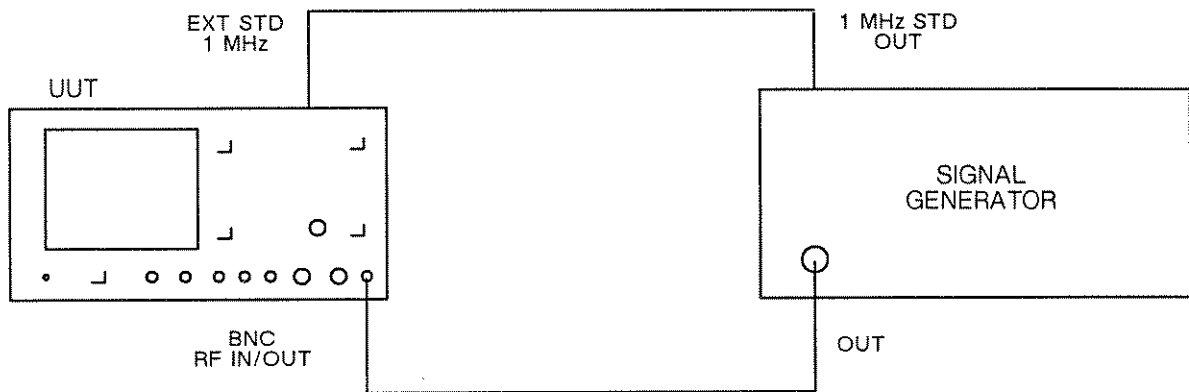

Fig. 5-9 Test equipment connections for RF frequency meter accuracy

- (2) Set the UUT to TX, BNC input socket.
- (3) Set the signal generator to carrier frequency 1000 MHz, level 7 dBm, modulation off.
- (4) Check that the UUT indicates the signal generator frequency  $\pm 1$  digit.
- (5) Repeat the above for frequencies between 1.5 and 1000 MHz.

## Input sensitivity specification

This section checks that the instrument performs to the following specification:-

N socket sensitivity 5 mW.  
In one-port duplex mode, sensitivity  
is reduced to 20 mW.

## Input sensitivity test gear

The following test gear is required to check the above specification:-

Description	Minimum spec.	Example
Signal generator	Synthesized freq. 1.5-1000 MHz. 1 MHz standard output. Level 13 dBm, FM	Marconi 2019A
Power meter & sensor	1.5-1000 MHz. -30 to +20 dBm.	Marconi 6960A + Sensor 6912

## Checking input sensitivity

Proceed as follows:-

- (1) Set the UUT to TX, N input socket.
- (2) Set the signal generator to carrier frequency 100 MHz, modulation off.

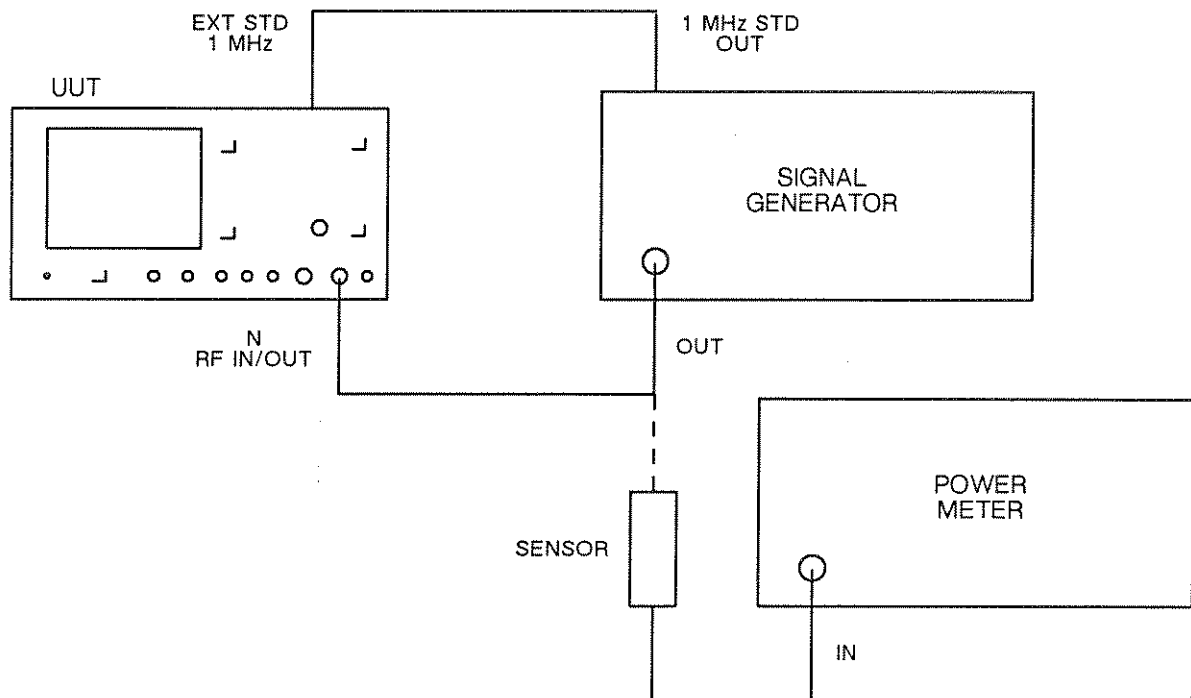

Fig. 5-10 Test equipment connections for RF frequency meter input sensitivity

- (3) Connect the power meter to the signal generator output (see Fig. 5-10) and adjust the RF level to give 5 mW indication on the power meter.
- (4) Connect the signal generator to the UUT N input socket (see Fig. 5-2). Check that the UUT frequency meter is locked and stable and indicates the frequency set on the signal generator  $\pm 10$  Hz.
- (5) Repeat the above for frequencies from 1.5 to 1000 MHz.

## AF FREQUENCY METER

The AF frequency meter checks comprise frequency accuracy and sensitivity.

### Frequency accuracy and sensitivity specification

This section checks that the instrument performs to the following specification:-

Frequency range: 20 Hz - 20 kHz  
 Frequency accuracy: As internal standard  $\pm 1$  digit  
 $\pm 0.1$  Hz/0.02%. Sensitivity 50 mV

### Frequency accuracy and sensitivity test gear

The following test gear is required to check the above specification:-

Description	Minimum spec.	Example
LF synthesizer	20 Hz-20 kHz. 1 MHz standard output.	HP 3325A or B
50 $\Omega$ termination	50 $\Omega$ , 1/2 W.	Suhner
DVM	0.5% accuracy.	Datron 1065A

### Checking frequency accuracy and sensitivity

Note that the following method checks the AF frequency meter is working correctly. However, overall accuracy depends upon the correct setting of the internal 10 MHz standard (see under 'Adjustments' in the board checks for AC1. Proceed as follows:-

- (1) Connect the equipment as shown in Fig. 5-11.
- (2) Set the UUT to audio test, distortion off, 50 kHz LOW PASS filter, AC coupled.
- (3) Set the synthesized LF generator to give a 20 kHz sinewave at 50 mV RMS.
- (4) Set the DVM to read AC and RMS.
- (5) Adjust the LF synthesizer output level until the DVM indicates 50 mV.
- (6) Check that the frequency meter on the UUT indicates the frequency set on the synthesizer  $\pm 1$  digit  $\pm 0.1$  Hz/0.02%.
- (7) Repeat the above for random LF synthesizer frequencies between 20 Hz and 20 kHz.



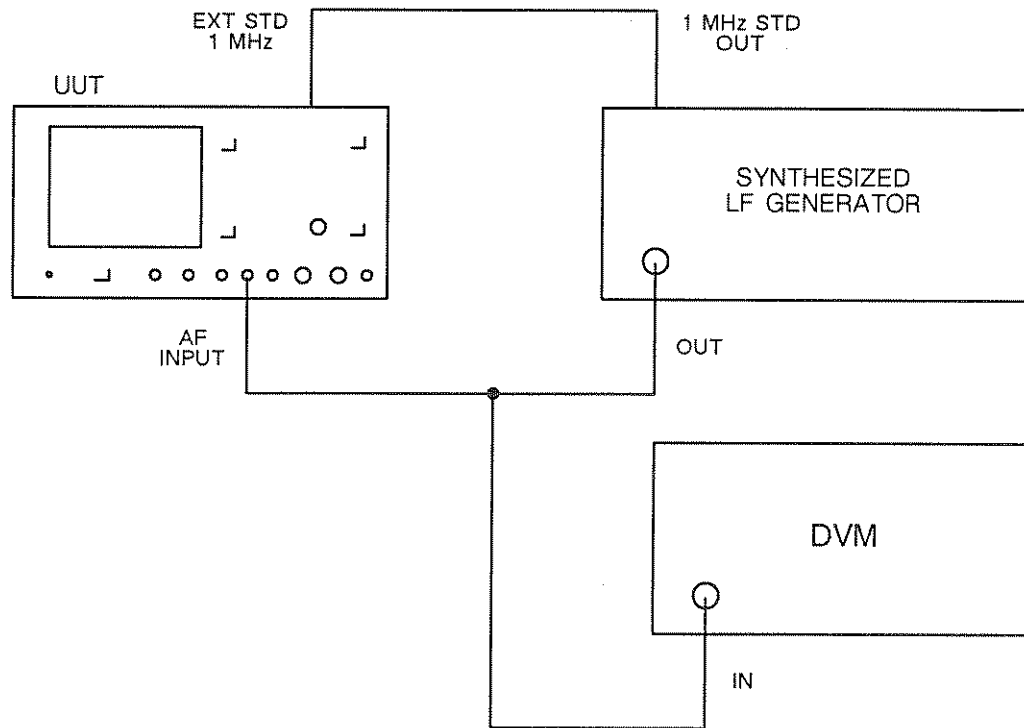

Fig. 5-11 Test equipment connections for AF frequency meter accuracy and sensitivity

## AF GENERATOR

The AF generator checks comprise output level accuracy, distortion, frequency accuracy, DC offset, residual noise, and waveform shapes. These checks are for testing AF GEN 1. Testing of the second AF generator can be carried out in the same way but with GEN 1 off and GEN 2 on.

### Output level accuracy specification

This section checks that the instrument performs to the following specification:-

Level range : 0.1 mV-4.095 V RMS (sine and square)  
0.1 mV-4.095 V (triangle)

Level accuracy :  $\pm 5\%$   $\pm 1$  step, 50 Hz-15 kHz.

### Output level accuracy test gear

The following test gear is required to check the above specification:-

Description	Minimum spec.	Example
RMS voltmeter	AC voltage 50 Hz-15 kHz. Accuracy better than 0.5% of reading, 50 mV-4.095 VRMS.	Datron 1065A

## Checking output level accuracy

Proceed as follows:-

- (1) Connect the equipment as shown in Fig. 5-12.

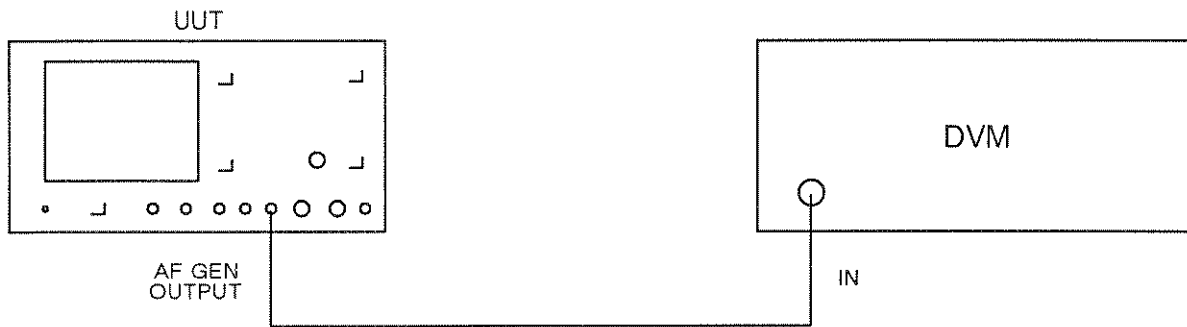

Fig. 5-12 Test equipment connections for AF generator output level accuracy

- (2) Set the UUT to audio test mode by pressing RX, AF GEN. Ensure that GEN 1 is switched on and GEN 2 is off and that the shape selected is sine. (This can be confirmed or altered under AUDIO SETUP in the TONES menu.) Set GEN 1 frequency 1 kHz, level 1 V.
- (3) Check that the voltmeter reads the AF generator level set on the UUT  $\pm 5\% \pm 1$  count.
- (4) Repeat for random AF generator frequencies and levels. Note if checking very low levels the limitations of the DVM being used should be taken into account.

## Distortion specification

This section checks that the instrument performs to the following specification:-

Less than 1% up to 15 kHz.  
Less than 0.5% at 1 kHz.

## Distortion test gear

The following test gear is required to check the above specification:-

Description	Minimum spec.	Example
Distortion meter	Frequency range 50 Hz-15 kHz. Better than 0.2% distortion.	Marconi TF 2331A

## Checking distortion

Proceed as follows:-

- (1) Connect the equipment as shown in Fig. 5-13.

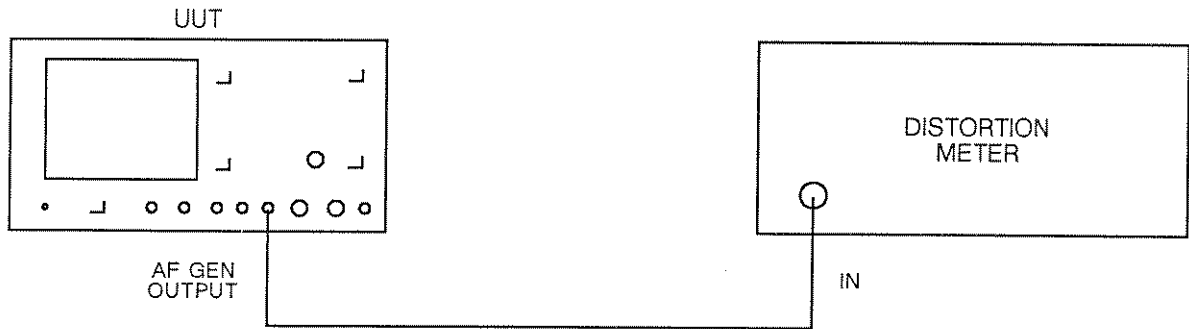

Fig. 5-13 Test equipment connections for AF generator distortion

- (2) Set the UUT to audio test mode by pressing RX, AF GEN. Ensure GEN 1 is on, GEN 2 is off and that the shape is sine. (This can be confirmed or altered under AUDIO SETUP in the TONES menu.) Set GEN 1 frequency 5 kHz, level 2 V.
- (3) Tune in the distortion meter and check that the distortion indicated is less than 2%.
- (4) Repeat for random levels and frequencies between 50 Hz and 15 kHz.
- (5) Change the UUT AF generator frequency to 1 kHz.
- (6) Tune in the distortion meter and check that the distortion indicated is less than 0.5%.

## AF generator frequency accuracy specification

This section checks that the instrument performs to the following specification:-

$\pm 0.01$  Hz from 10 Hz to 100 Hz.  
 $\pm 0.1$  Hz from 100 Hz to 20 kHz.

## Frequency accuracy test gear

The following test gear is required to check to the above specification:-

Description	Minimum spec.	Example
Frequency counter/timer	50 Hz-15 kHz, Accuracy better than 0.1 Hz.	Marconi 2438

## Checking frequency accuracy

Proceed as follows:-

- (1) Connect the equipment as shown in Fig. 5-14.

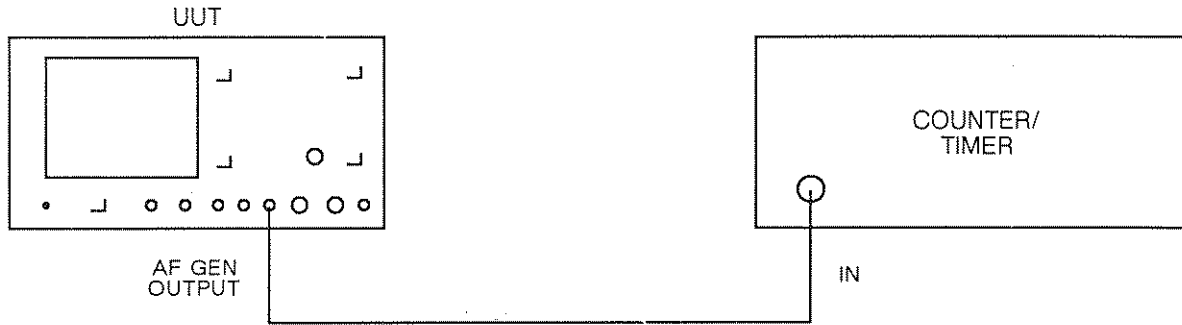

Fig. 5-14 Test equipment connections for AF generator frequency accuracy

- (2) Set the UUT to audio test mode by pressing RX, AF GEN. Ensure GEN 1 is on, GEN 2 is off and that the shape is sine. (This can be confirmed or altered under AUDIO SETUP in the TONES menu.) Set GEN 1 frequency to 15 kHz, level 1 V.
- (3) Set the counter/timer to read period (to gain the required resolution).
- (4) Check that the counter/timer reads between 66666.2 and 66667.1 ns (15 kHz  $\pm$ 0.1 Hz).
- (5) Repeat the above for random frequencies between 100 kHz and 20 kHz checking on the counter/timer that the frequency selected is within  $\pm$ 0.1 Hz.
- (6) Repeat for random frequencies between 10 Hz and 100 Hz checking on the counter/timer that the frequency selected is within  $\pm$ 0.01 Hz.

## AF generator DC offset, residual noise and waveform check

This section checks that the instrument performs to the following specification:-

Residual noise less than 0.1 mV RMS in psophometric band  
DC offset less than 100 mV DC sine, triangle and square.

## DC offset, residual noise and spurious signals test gear

The following test gear is required to check the above specification:-

Description	Minimum spec.	Example
DVM	DC measurement down to 1 mV.	Marconi 2610
Audio analyzer	SINAD measurement, psophometric filter.	HP 8903A or B
Oscilloscope	Frequency 20 kHz	Tektronix 2235

## Checking DC offset

Proceed as follows:-

- (1) Connect the equipment as shown in Fig. 5-15.
- (2) Set the UUT to audio test mode by pressing RX, AF GEN. Ensure GEN 1 is on, GEN 2 is off and that the shape is sine. (This can be confirmed or altered under AUDIO SETUP in the TONES menu.) Set GEN 1 frequency to 50 Hz, level 0 mV.
- (3) Set the DVM to measure DC level.
- (4) Check that the DC level indicated on the DVM is less than 100 mV DC.
- (5) Repeat the above for random frequencies between 50 Hz and 15 kHz.



Fig. 5-15 Test equipment connections for AF generator DC offset

## Checking residual noise

Proceed as follows:-

- (1) Connect the equipment as shown in Fig. 5-16.



Fig 5-16 Test equipment connections for AF generator residual noise

- (2) Set the UUT to audio test mode by pressing RX, AF GEN. Ensure GEN 1 is on, GEN 2 is off and that the shape is sine. (This can be confirmed or altered under AUDIO SETUP in the TONES menu.) Set GEN 1 frequency to 50 Hz, level 0 mV.

- (3) Set the audio analyzer to AC level, psophometric band-pass filter on. All other filters off.
- (4) Check that the AC level indicated on the audio analyser is less than 0.2 mV RMS.
- (5) Repeat the above for random frequencies between 50 Hz and 15 kHz.

### Checking waveform shapes

Proceed as follows:-

- (1) Connect the oscilloscope to the UUT AF GEN OUTPUT socket.
- (2) Set the oscilloscope controls to DC coupled, 0.5 V/div, 0.2  $\mu$ s/div time-base.
- (3) Set the UUT to AF audio control mode by pressing RX, AF GEN, TONES, audio setup.
- (4) Set GEN 1 frequency to 1 kHz, level 1 V, shape square. Ensure that GEN 2 is switched off.
- (5) Check on the oscilloscope for a square waveform equal about ground of 4 divisions.
- (6) Set GEN 1 shape to triangle and check on the oscilloscope for a triangle waveform equal about ground of 4 divisions.
- (7) Set GEN 1 shape to saw and check on the oscilloscope for a saw-tooth waveform equal about ground of 4 divisions.

**Note...**

The above check can be carried out using the UUT oscilloscope but this gives slight degradation of the shapes.

### DTMF ENCODER AND DECODER

The DTMF encoder and decoder can be checked by carrying out a back-to-back test.

Proceed as follows:-

- (1) Connect the UUT AF GEN OUTPUT socket to the AF INPUT socket.
- (2) Select the audio DTMF generator and receiver display by pressing the following keys from switch on: RX, AF GEN, TONES, DTMF.

1	2	3	4	5	6	7	8	9	0	*	#	A	B	C	D
---	---	---	---	---	---	---	---	---	---	---	---	---	---	---	---

- (4) Clear the receive data window.
- (5) Turn the UUT volume control up slightly and press the SEND key. The tones should now be heard on the loudspeaker and should also appear decoded in the receive data window.

## DISTORTION/SINAD METER

The distortion/SINAD meter check comprises distortion measurement accuracy.

### Distortion measurement accuracy specification

This section checks that the instrument performs to the following specifications:-

Distortion measurement accuracy:  $\pm 5\%$  of reading  $> 0.5\%$  distortion.  
SINAD:  $\pm 1$  dB.

### Distortion measurement accuracy test gear

The following test gear is required to check the above specification:-

Description	Minimum spec.	Example
Distortion meter	0.2% distortion at 1 kHz.	Marconi 2331A

### Checking distortion accuracy

Proceed as follows:-

- (1) Connect the UUT AF GEN OUTPUT socket to the UUT AF INPUT socket.
- (2) Set the UUT to audio test mode. Select distortion and 50 kHz LP filter. Set AF GEN 1 to give a sine wave of frequency 1 kHz at a level of 1 V. Set AF GEN 2 to give a sine wave of frequency 3.5 kHz at a level of 206 mV.
- (3) Adjust the level of AF GEN 2 until the UUT distortion meter reads exactly 20.0%.
- (4) Remove the AF GEN OUTPUT from the AF INPUT and connect the AF GEN OUTPUT to the distortion meter.
- (5) Remove the distortion meter to 1 kHz and check that the distortion indicated is between 18.5 and 21.5%.

## RF POWER METER

The RF power meter check comprises measurement accuracy.

### Measurement accuracy specification

This section checks that the instrument performs to the following specification:-

Accuracy :  $\pm 10\% \pm 1$  count up to 500 MHz  
 $\pm 15\% \pm 1$  count up to 960 MHz  
 $\pm 20\% \pm 1$  count up to 1000 MHz

## Measurement accuracy test gear

The following test gear is required to check to the above specification:-

Description	Minimum spec.	Example
Calibrated power source (as below)	Overall uncertainty of 2% up to 500 MHz 3% up to 1000 MHz.	
Signal generator	1.5-1000 MHz, RF level 13 dBm.	Marconi 2019A
RF amplifier	1.5-1000 MHz. Min: 3 W 40 dB gain	Marconi TF 2177
Directional coupler	1.5-1000 MHz, 20 dB coupling.	HP 778D (100-1000 MHz) + Mini Circuits ZFDC203 (1.5-100 MHz)
Power meter & Sensor	1.5-1000 MHz, $\pm 0.15$ dB accuracy, -30 dBm to +20 dBm.	Marconi 6960A, 6912, sensor

## Checking measurement accuracy

Proceed as follows:-

- (1) Connect the equipment as shown in Fig. 5-17, using the high frequency coupler. But note that the power source must be calibrated at the frequencies to be checked.
- (2) Set the UUT to TX, N input socket.
- (3) Set the power source to give an output of 2 W at 100 MHz.
- (4) Check that the UUT indicates 2 W  $\pm 10\%$   $\pm 1$  digit.
- (5) Set the power source to give 220 mW.
- (6) Check that the UUT indicates 220 mW  $\pm 10\%$   $\pm 1$  digit.
- (7) Repeat the above for random frequencies between 100 and 500 MHz.
- (8) Repeat for random frequencies between 500 and 960 MHz and check that the UUT indicates the power sent  $\pm 15\%$   $\pm 1$  digit.
- (9) Repeat for random frequencies between 960 and 1000 MHz and check that the UUT indicates the power sent  $\pm 20\%$   $\pm 1$  digit.
- (10) Replace the high frequency directional coupler (HP 778D) with the low frequency coupler.
- (11) Repeat the above checks for random frequencies between 1.5 and 100 MHz and check that the UUT indicates the power sent  $\pm 10\%$   $\pm 1$  digit.
- (12) Set the UUT to one port duplex mode and repeat the above checks.



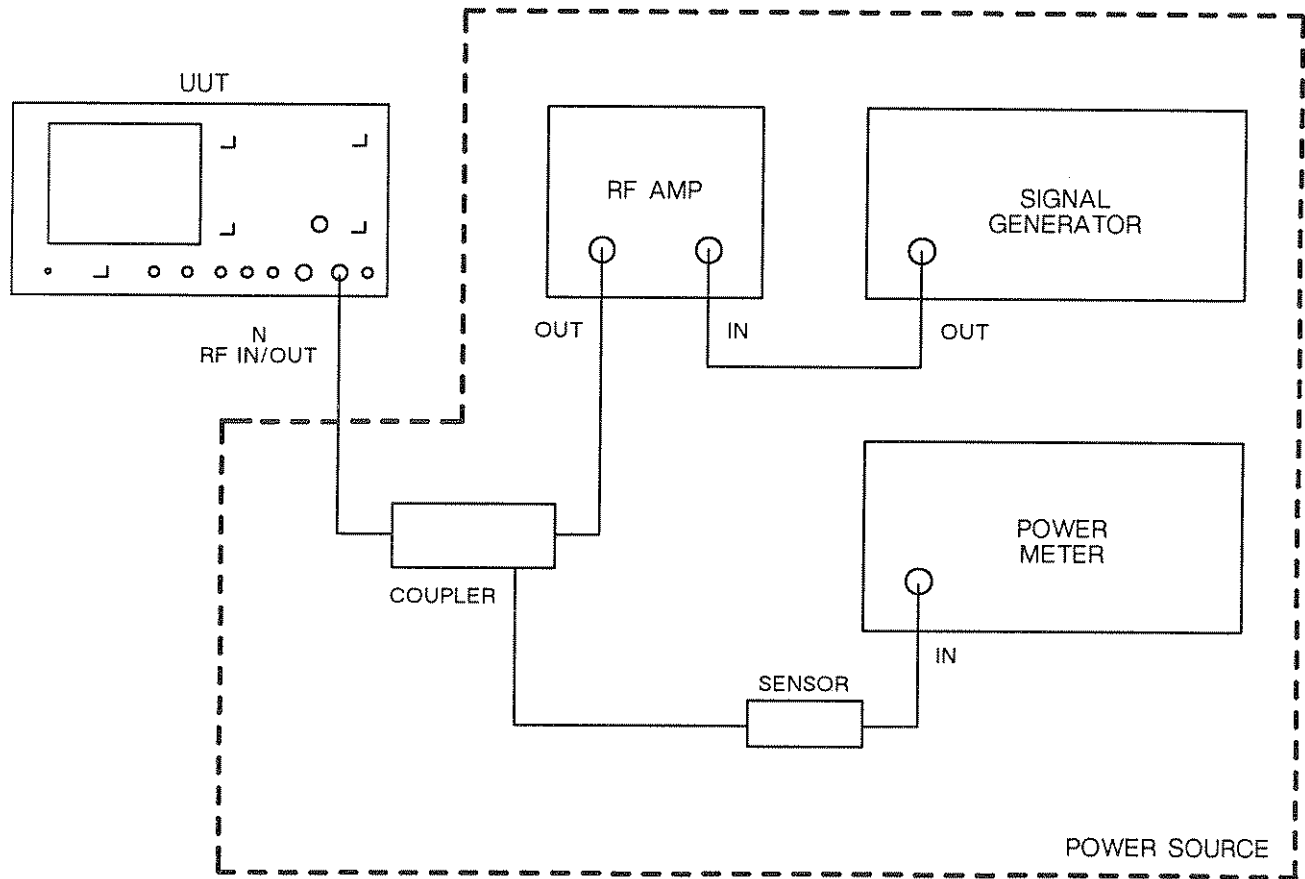

Fig. 5-17 Test equipment connections for RF power meter measurement accuracy

**Note...**

The power source must be a calibrated system with an overall uncertainty not greater than 2% up to 500 MHz and 3% up to 1000 MHz.

## SELCALL

The Selcall checks comprise tones operation.

### Tones operation test gear

The only test gear required is a second fully operational 2955A.

### Checking Selcall tones

Proceed as follows:-

- (1) Connect the equipment as shown in Fig. 5-18.
- (2) Set the UUT to RX, carrier frequency 100 MHz, level 0 dBm, modulation off, BNC output socket.
- (3) On the UUT press TONES and select sequential then CCIR.

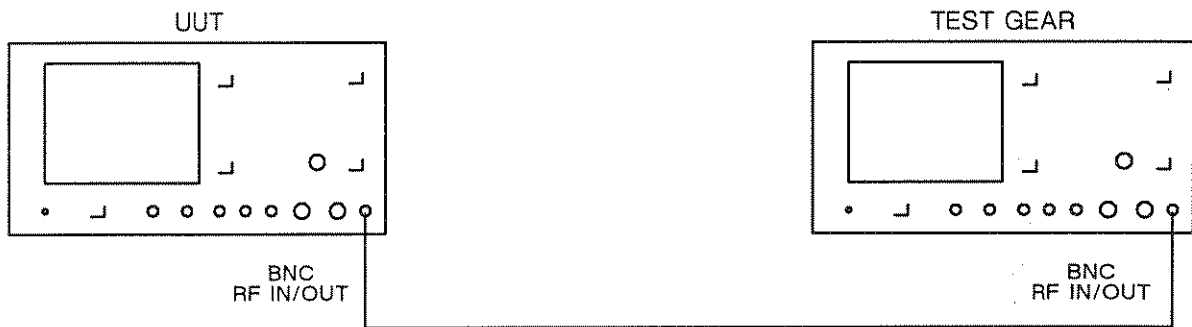

Fig. 5-18 Test equipment connections for Selcall tones performance checks

- (4) Set the 2955A test gear to TX, BNC input socket. Press TONES and select sequential then CCIR.
- (5) On the UUT enter tone numbers 1 to 10 using the data keys. Press the tone burst key.
- (6) Check that the transmitted tones 1 to 10 appear on the 2955A test gear with 0% error.
- (7) Repeat the above with the instrument settings reversed, and check that the UUT receives the tones correctly.

## RF GENERATOR

The RF generator checks comprise: output level, RF accuracy, AM and FM internal accuracy, AM and FM distortion, external AM and FM, RF leakage, FM on CW, and carrier harmonics, sub-harmonics and spurious signals.

### Output level specification

This section checks that the instrument performs to the following specification:-

$\pm 2$  dB for levels above  $-127$  dBm

### Output level test gear

The following test gear is required to check the above specification:-

Description	Minimum spec.	Example
Power meter & sensors	0.4-1000 MHz, -65 to 0dBm, accuracy better than $\pm 0.15$ dB.	Marconi 6960 + Sensors 6920 & 6912
Spectrum analyzer	Frequency 100 MHz, ability to reduce noise floor below $-96$ dBm.	Marconi TF 2370

## Checking output level

Proceed as follows, but note that checking low levels (less than  $-60$  dBm) requires the use of specialised attenuator measurement equipment:-

- (1) Connect the equipment as shown using the 6920 sensor.

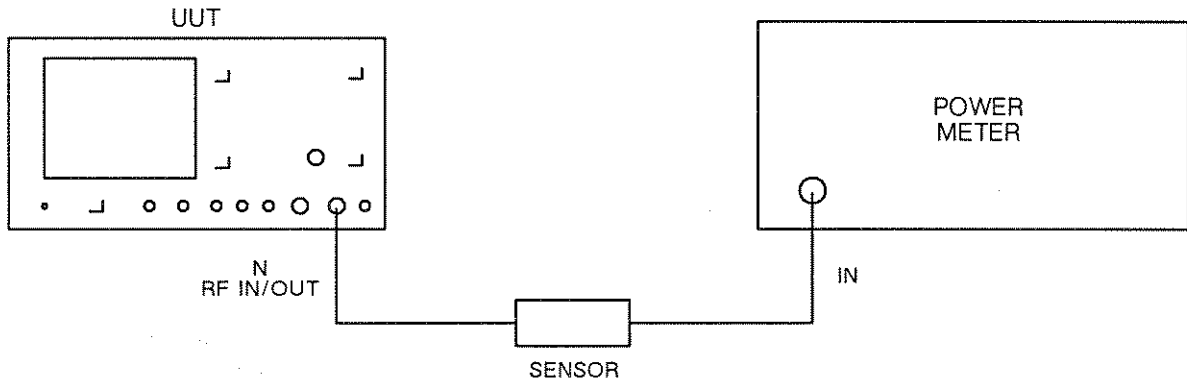

*Fig. 5-19 Test equipment connections for RF generator output level*

- (2) Set the UUT to RX, RF GEN, carrier frequency 300 MHz, level  $-20.5$  dBm, INC 1 dB, MOD OFF, N-type output socket.
- (3) Check that the power meter reads  $-20.5$  dBm  $\pm 2$  dB.
- (4) Decrement the UUT in 1 dB steps using the increment level down keys to  $-25.5$  dBm and check on the power meter that each step is within  $\pm 2$  dB of the level selected.
- (5) Check that the power meter reads within  $\pm 2$  dB at the levels and frequencies given in the following table:-

UUT gen freq	UUT level	Reason
300 MHz	$-26$ dBm	Checks internal 10 dB pad
300 MHz	$-36$ dBm	Checks 20 dB pad in attenuator
300 MHz	$-56$ dBm	Checks 1st 40 dB pad in attenuator
1000 MHz	$-25$ dBm	Checks flatness across frequency band
10 MHz	$-25$ dBm	

- (6) Replace the 6920 head with the 6912 head and check the level at the following points is within  $\pm 2$  dB.

UUT gen freq	UUT level
400 kHz	-15 dBm
20 MHz	-15 dBm
100 MHz	-15 dBm
300 MHz	-15.5 dBm
300 MHz	-16.5 dBm
300 MHz	-17.5 dBm
300 MHz	-18.5 dBm
300 MHz	-19.5 dBm
500 MHz	-15 dBm
1000 MHz	-15 dBm

- (7) Connect the spectrum analyzer to the UUT BNC RF OUTPUT socket.
- (8) Set the UUT to give an RF GEN frequency to 100 MHz and level -96 dBm from the BNC socket. Check on the spectrum analyzer for a level of -96 dBm. It is not possible to check to  $\pm 2$  dBm but it indicates that the last 40 dB of the attenuator is switching in correctly.

### RF generator frequency accuracy specification

This section checks that the instrument performs to the following specification:-

Accuracy: As internal standard

### RF generator frequency accuracy test gear

The following test gear is required to check the above specification:-

Description	Minimum spec.	Example
Frequency counter	0.4-1000 MHz, 1 MHz standard output	Marconi 2435

### Checking RF generator frequency accuracy

Note that the following method checks that the frequency synthesizer is working correctly. However, overall accuracy depends upon the correct setting of the internal 10 MHz standard (see under 'Adjustments' in the board checks for AC1). Proceed as follows:-

- (1) Connect the equipment as shown in Fig. 5-20.

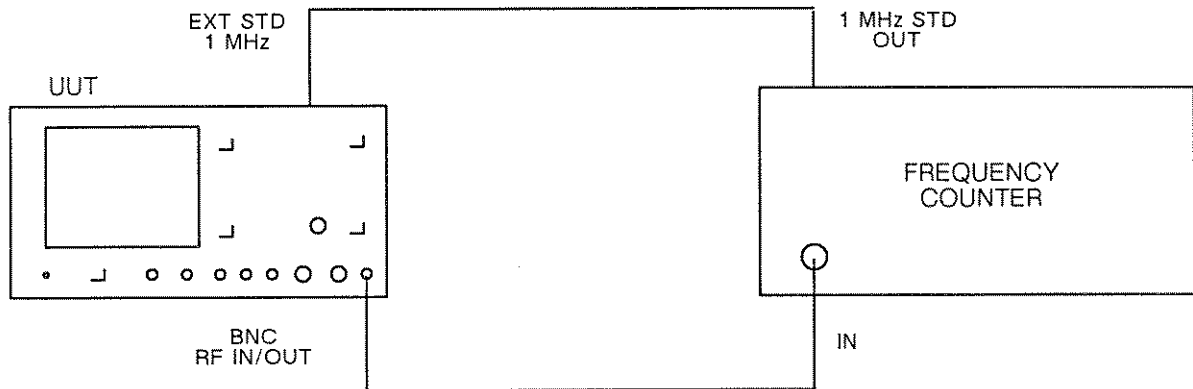

Fig. 5-20 Test equipment connections for RF generator frequency accuracy

- (2) Set the UUT to RX, RF GEN, carrier frequency 1000 MHz, level 0 dBm, modulation off, BNC output socket.
- (3) Check that the counter displays the frequency set on the UUT  $\pm 20$  Hz.
- (4) Repeat the above for random frequencies between 0.4 and 1000 MHz.

### AM internal accuracy specification

This section checks that the instrument performs to the following specification:-

$\pm 7\%$   $\pm 1$  digit at 1 kHz.

$\pm 10\%$  of setting  $\pm 1$  digit from 50 Hz to 5 kHz only and 0 to 70% AM only.

$\pm 15\%$  of setting  $\pm 1$  digit from 50 Hz to 15 kHz and 0 to 85% AM

### AM internal accuracy test gear

The following test gear is required to check the above specification:-

Description	Minimum spec.	Example
Modulation meter	AM measurement 0.5-1000 MHz, accuracy 1% at 1 kHz rate, 2.5% at rates 50 Hz-15 kHz.	Marconi 2305

### Checking AM internal accuracy

Proceed as follows:-

- (1) Connect the equipment as shown in Fig. 5-21.

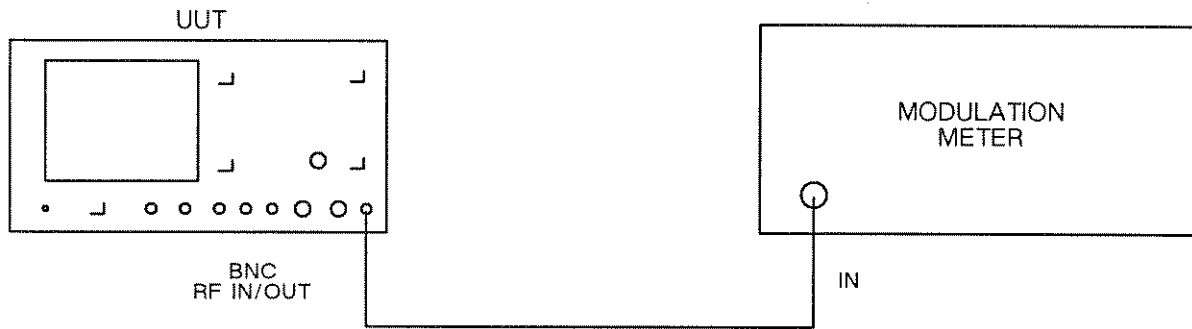

Fig. 5-21 Test equipment connections for RF generator AM and FM internal accuracy

- (2) Set the UUT to RX, RF GEN, carrier frequency 100 MHz, BNC output socket, level 0 dBm, amplitude modulation frequency 1 kHz sine wave, modulation level 85%, distortion/ SINAD/SN off, BNC output socket.
- (3) Set the modulation meter to monitor AM with 0.3 to 3.4 kHz band-pass filter selected.
- (4) Check that the AM indicated on the modulation meter is within  $\pm 7\% \pm 1$  digit.
- (5) Repeat the above at random levels of modulation between 0 and 85%, at random carrier frequencies between 1.5 and 400 MHz, and at random RF levels.
- (6) Repeat with random modulation frequencies between 50 Hz and 5 kHz and modulation levels between 0 and 70%, while checking that the modulation meter reading is within  $\pm 10\%$  of setting  $\pm 1$  digit. Ensure that the correct filters are selected on the modulation meter according to the modulation rate being used.
- (7) Repeat with random modulation frequencies between 50 kHz and 15 kHz and modulation levels between 0 and 85%, while checking that the modulation meter reading is within  $\pm 15\%$  of setting  $\pm 1$  digit. Ensure that the correct filters are selected on the modulation meter according to the modulation rate being used.

### FM internal accuracy specification

This section checks that the instrument performs to the following specification:-

- >7%  $\pm 10$  Hz (at 1 kHz)
- >10% (50 Hz to 15 kHz)

### FM internal accuracy test gear

The following test gear is required to check the above specification:-

Description	Minimum spec.	Example
Modulation meter	0.5-1000 MHz, FM accuracy 2%.	Marconi 2305

## Checking FM internal accuracy

Proceed as follows:-

- (1) Connect the equipment as shown in Fig. 5-22.
- (2) Set the UUT to RX, RF GEN, carrier frequency 100 MHz, BNC output socket, level 0 dBm, FM frequency 1 kHz sine wave, modulation level 25 kHz, distortion/SINAD/SN off.
- (3) Set the modulation meter to monitor FM with 0.3 to 3.4 kHz band-pass filter selected.
- (4) Check that the FM deviation indicated on the modulation meter is within  $\pm 7\%$   $\pm 10$  Hz.
- (5) Repeat the above at random deviations between 0 and 25 kHz, and random carrier frequencies between 0.5 and 1000 MHz.
- (6) Repeat for modulation rates between 50 Hz and 15 kHz and check that the modulation meter deviation reading is within  $\pm 10\%$ . Ensure that the correct filters are selected on the modulation meter according to the modulation rate being used.

## AM and FM distortion specification

This section checks that the instrument performs to the following specification:-

- AM: <2% distortion at 1 kHz with 30% AM in a 0.3 to 3.4 kHz bandwidth.  
 FM: <1% distortion at 1 kHz with 5 kHz deviation in a 0.3 to 3.4 kHz bandwidth.

## AM and FM distortion test gear

The following test gear is required to check the above specification:-

Description	Minimum spec.	Example
Modulation meter	AM & FM modulation, demodulated output.	Marconi 2305*
Distortion meter	Accuracy better than 0.3% at 1 kHz.	Marconi 2331A

\* If the modulation meter has the distortion option fitted, the distortion meter is not required.

## Checking AM and FM distortion

Proceed as follows:-

- (1) Connect the equipment as shown in Fig. 5-22.

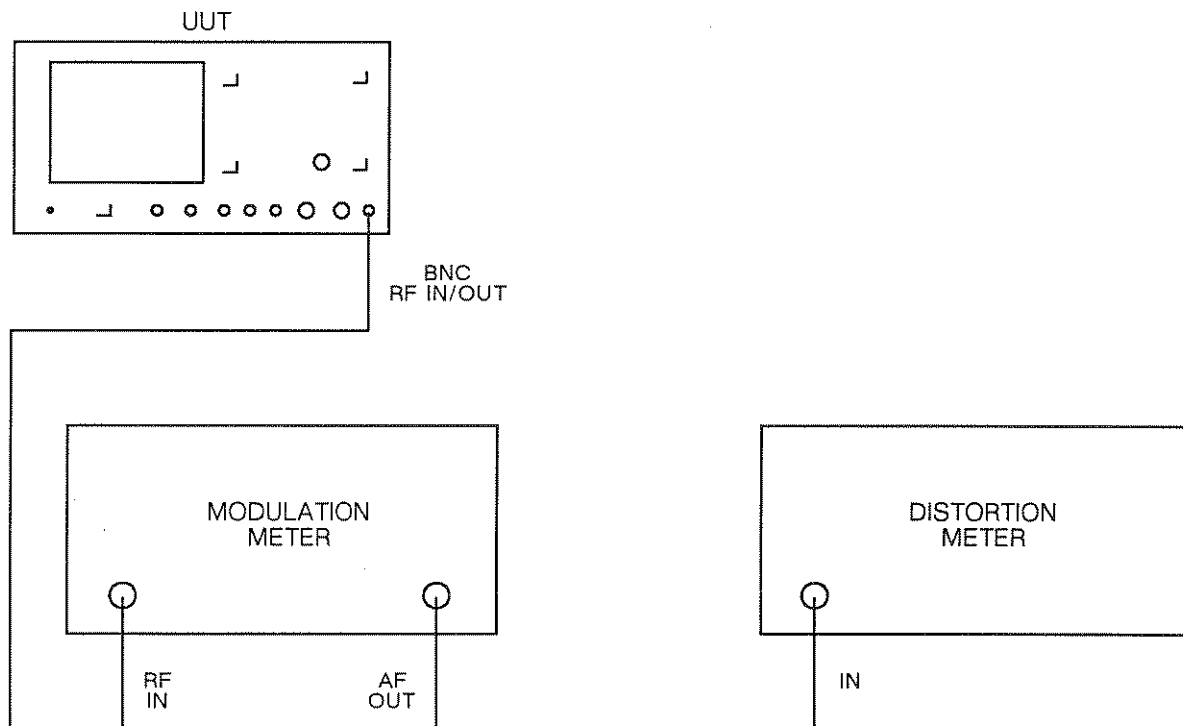

Fig. 5-22 Test equipment connections for RF generator AM and FM distortion

- (2) Set the UUT to RX, RF GEN, carrier frequency 100 MHz, BNC output socket, level 0 dBm, AM frequency 1 kHz sine wave, modulation depth 30%, distortion/SINAD/SN off.
- (3) Set the modulation meter to monitor AM with 0.3 to 3.4 kHz bandwidth filter selected.
- (4) Tune in the distortion meter and check that the reading is less than 2%.
- (5) Change the UUT modulation to 1 kHz FM sine wave with deviation 5 kHz.
- (6) Set the modulation meter to monitor FM with 0.3 to 3.4 kHz band-width filter selected.
- (7) Tune in the distortion meter and check that the reading is less than 1%.

### External AM and FM specification

This section checks that the instrument performs to the following specification:-

AM sensitivity: 0.76 V p-p for 30% AM,  
 $\pm 10\%$ ,  $\pm 1\%$  AM  
 FM sensitivity: 0.5 V p-p for 10 kHz deviation,  
 $\pm 10\%$ .



## External AM and FM test gear

The following test gear is required to check the above specification:-

Description	Minimum spec.	Example
Modulation meter	1% AM accuracy at 1 kHz, 2.5% at rate 50 Hz-15 kHz, FM accuracy 2%.	Marconi 2305
LF synthesizer	50 Hz-15 kHz range	HP 3325A or B
DVM	0.5% accuracy	Datron 1065A

## Checking external AM and FM

Proceed as follows:-

- (1) Connect the equipment as shown in Fig. 5-23.

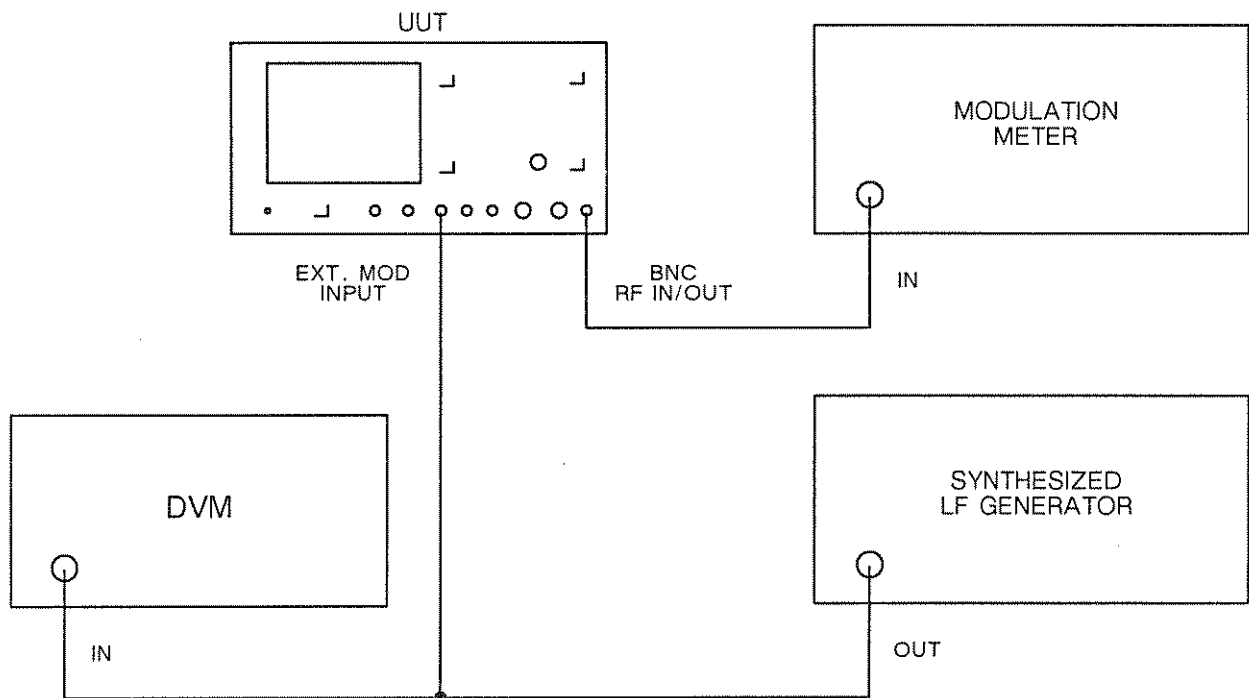

Fig. 5-23 Test equipment connections for RF generator external AM and FM

- (2) Set the UUT to RX, RF GEN, carrier frequency 100 MHz, BNC output socket, level 0.0 dBm, AM frequency 1 kHz, modulation depth 0%, distortion/SINAD/SN off.
- (3) Set the synthesized LF generator to give a 1 kHz sinewave output and adjust the level to give an RMS reading on the DVM of 268.7 mV (0.76 V pk-pk).
- (4) Set the modulation meter to monitor AM and select the 0.3 to 3.4 kHz band-pass filter.

- (5) Check that the modulation meter displays 30% modulation  $\pm 10\% \pm 1\%$  AM.
- (6) Set the UUT to FM modulation level 0 kHz.
- (7) Set the synthesized LF generator to give a 1 kHz sine wave output and adjust the level to give an RMS reading on the DVM of 176.8 mV (0.5 V pk-pk).
- (8) Set the modulation meter to monitor FM with the 0.3 to 3.4 kHz band-pass filter selected.
- (9) Check that the modulation meter displays 5 kHz deviation  $\pm 10\%$ .
- (10) Repeat the above checks for external modulation frequencies between 50 Hz and 15 kHz. Ensure that the correct filters are selected on the modulation meter according to the modulation rate being used.

### RF leakage specification

This section checks that the instrument performs to the following specification:-

$< 0.5 \mu\text{V}$  PD generated in a  $50 \Omega$  load by a 2-turn 25 mm loop as near as 25 mm to the case of the instrument with the output set to less than  $-20 \text{ dBm}$  and the output terminated in a  $50 \Omega$  sealed load.

### RF leakage test gear

The following test gear is required to check the above specification:-

Description	Minimum spec.	Example
Spectrum analyser	0.4-1000 MHz	Marconi TF 2370 + TF 2373.
50 $\Omega$ sealed load	--	--
2-turn 25 mm loop	--	--

### Checking RF leakage

Proceed as follows:-

- (1) Connect the equipment as shown in Fig. 5-24, with the 50  $\Omega$  load connected to the BNC output socket.

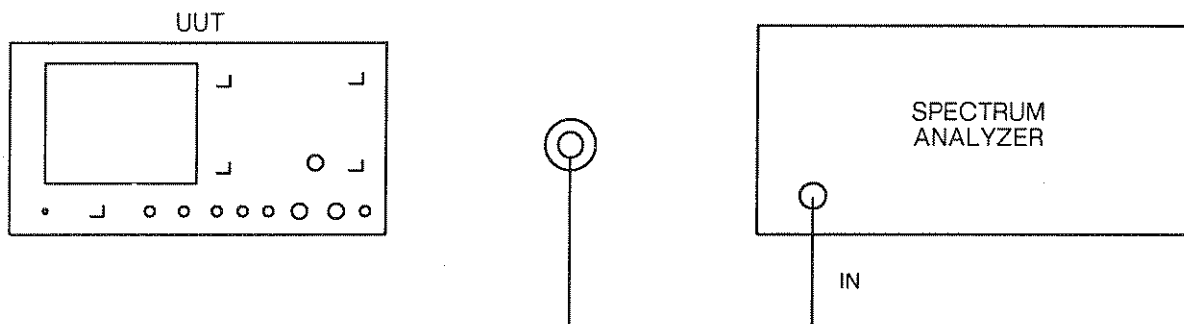

Fig. 5-24 Test equipment connections for RF generator RF leakage

- (2) Set the UUT to RX, RF GEN, carrier frequency 500 MHz, level -20 dBm, BNC output socket.
- (3) Set the spectrum analyzer to monitor 500 MHz.
- (4) Hold the loop 25 mm away from the UUT case and check that the level picked up on the spectrum analyzer is less than 0.5  $\mu$ V PD.

## FM on CW specification

This section checks that the instrument performs to the following specification:-

<30 Hz up to 520 MHz  
(0.3 - 3.4 kHz weighted RMS).  
<60 Hz up to 1000 MHz  
(0.3 - 3.4 kHz weighted RMS).

## FM on CW test gear

The following test gear is required to check the above specification:-

Description	Minimum spec.	Example
Modulation meter	FM noise average, 0-1000 MHz, 0.3 to 3.4 kHz weighted filter.	Marconi 2305

## Checking FM on CW

Proceed as follows:-

- (1) Connect the equipment as shown in Fig. 5-25.



Fig. 5-25 Test equipment connections for RF generator FM on CW

- (2) Set the UUT to RX, RF GEN, carrier frequency 520 MHz, BNC output socket, level 0 dBm, modulation off.
- (3) Set the modulation meter to monitor FM, with noise average and 0.3 to 3.4 kHz band-pass filter selected.

- (4) Check that the modulation meter indicates less than 30 Hz.
- (5) Repeat the above for random frequencies below 520 MHz.
- (6) Change the UUT frequency to 1000 MHz and check that the modulation meter reads less than 60 Hz.
- (7) Repeat the above for random frequencies between 520 and 1000 MHz.

### Carrier harmonics, sub-harmonics and spurious signals specification

This section checks that the instrument performs to the following specification:-

Harmonics:	Harmonics are in band 0.4-1000 MHz only. Less than -20 dBc up to 1.5 MHz. Less than -25 dBc 1.5-250 MHz. Less than -20 dBc 250-1000 MHz.
Sub-harmonics:	None up to 530 MHz. Less than -25 dBc to 1000 MHz.
Spurious signals:	Carrier up to 88 MHz. Less than -45 dBc below 110 MHz Less than -35 dBc above 110 MHz. Carrier up to 1000 MHz. Less than -60 dBc.

### Harmonics, sub-harmonics and spurious signals test gear

The following test gear is required to check the above specification:-

Description	Minimum spec.	Example
Spectrum analyzer	0.4-1000 MHz.	Marconi 2370 + 2373

### Checking harmonics

Proceed as follows:-

- (1) Connect the equipment as shown in Fig. 5-26.



Fig. 5-26 Test equipment connections for RF generator harmonics, sub-harmonics and spurious signals

- (2) Set the UUT to RX, RF GEN, carrier frequency 1.5 MHz, BNC output socket, level 0 dBm, modulation off.
- (3) Adjust the spectrum analyzer controls to reference the 1.5 MHz fundamental on the top graticule line.
- (4) Check that the harmonics are less than  $-20$  dBc.
- (5) Repeat the above at random frequencies between 0.4 and 1.5 MHz.
- (6) Repeat at random frequencies between 1.5 and 250 MHz, checking that the harmonics are less than  $-25$  dBc.
- (7) Repeat at random frequencies between 250 and 1000 MHz, checking that the harmonics are less than  $-20$  dBc.

### Checking sub-harmonics

Proceed as follows:-

- (1) Connect the equipment as shown in Fig. 5-26.
- (2) Set the UUT to RX, RF GEN, carrier frequency 530 MHz, BNC output socket, level 0 dBm, modulation off.
- (3) Adjust the spectrum analyzer to reference the 530 MHz fundamental on the top graticule line.
- (4) Check that all sub-harmonics are less than  $-25$  dBc.
- (5) Repeat the above for RF generator frequencies between 530 and 1000 MHz.

### Checking spurious signals

Proceed as follows:-

- (1) Connect the equipment as shown in Fig. 5-26.
- (2) Set the UUT to RX, RF GEN, carrier frequency 88 MHz, BNC output socket level 0 dBm, modulation off.
- (3) Adjust the spectrum analyzer controls to reference the 88 MHz fundamental on the top graticule line.
- (4) Check that all spurious signals below 110 MHz are less than  $-45$  dBc and all spurious signals above 110 MHz are less than  $-35$  dBc.
- (5) Repeat for random carrier frequencies between 0.4 and 88 MHz.
- (6) Repeat for random carrier frequencies between 88 and 1000 MHz checking that all spurious signals are less than  $-60$  dBc.

Blank page.

## INDEX

	Page
Acceptance testing ... ..	5-1
<b>ACCESSORIES</b>	
Operation ... ..	3-5
Optional ... ..	1-20
Supplied ... ..	1-20
Accessory socket ... ..	2-4
<b>AF FREQUENCY METER</b>	
Performance data ... ..	1-13
<b>AF GENERATORS</b>	
Audio testing ... ..	3-36
Performance data ... ..	1-8
Technical description ... ..	4-2
Transmitter testing ... ..	3-8
<b>AF VOLTMETER</b>	
Audio testing ... ..	3-41
Performance data ... ..	1-14
Receiver testing ... ..	3-27
Technical description ... ..	4-2
Applications ... ..	3-18
<b>AUDIO SETUP</b>	
Audio testing ... ..	3-39
Duplex testing ... ..	3-34
Transmitter testing ... ..	3-11
<b>AUDIO TESTING</b>	
DTMF operation ... ..	3-60
Sequential tones operation ... ..	3-53
Battery option ... ..	2-2
<b>DCS ENCODER AND DECODER</b>	
Operation ... ..	3-62
Performance data ... ..	1-16
<b>DISTORTION METER</b>	
Audio testing ... ..	3-43
Performance data ... ..	1-13
Receiver testing ... ..	3-29
Technical description ... ..	4-6
Transmitter testing ... ..	3-16
<b>DTMF ENCODER AND DECODER</b>	
Operation ... ..	3-59
Performance data ... ..	1-16
<b>DUPLEX TESTING</b>	
DCS operation ... ..	3-63
DTMF operation ... ..	3-61
Operation ... ..	3-31
Sequential tones operation ... ..	3-53
Error codes ... ..	3-73
Front panel ... ..	3-2

## INDEX (continued)

	Page
GPIB	
Installation... ..	2-4
Operation ... ..	3-75
Performance data ... ..	1-18
HELP KEY	
Operation ... ..	3-67
Performance data ... ..	1-17
MODULATION GENERATOR	
Performance data ... ..	1-7
MODULATION METER	
Performance data ... ..	1-11
Technical description ... ..	4-4
Transmitter testing ... ..	3-14
MODULATION SETUP	
Duplex testing ... ..	3-34
Receiver testing ... ..	3-26
Mounting arrangements ... ..	
	2-2
NOISE METER	
Performance data ... ..	1-13
Receiver testing ... ..	3-29
OFF-AIR RECEIVER	
Operation ... ..	3-79
Performance data ... ..	1-16
Operating summaries ... ..	
	3-68
OSCILLOSCOPE	
Display ... ..	3-2
Performance data ... ..	1-15
Parameters ... ..	
	3-69
Performance data ... ..	
	1-5
POCSAG RADIO PAGER TESTING	
Operation ... ..	3-65
Performance data ... ..	1-16
POWER REQUIREMENTS	
Installation... ..	2-3
Performance data ... ..	1-18
Printer operation ... ..	
	3-77
Rack mounting ... ..	
	2-2
Rear panel ... ..	
	3-4
RECEIVER TESTING	
DCS operation ... ..	3-63
DTMF operation ... ..	3-60
Operation ... ..	3-19
Sequential tones operation ... ..	3-50
Revertive sequential tones operation ... ..	
	3-57



## INDEX (continued)

	Page
RF FREQUENCY METER	
Performance data ... ..	1-9
RF POWER METER	
Performance data ... ..	1-10
Technical description ... ..	4-3
Transmitter testing ... ..	3-12
RF SIGNAL GENERATOR	
Performance data ... ..	1-5
Receiver testing ... ..	3-20
Technical description ... ..	4-1
Safety testing ... ..	2-3
SELCALL (SEQUENTIAL TONES) ENCODER AND DECODER	
Operation ... ..	3-48
Performance data ... ..	1-15
Self testing ... ..	3-72
Special features ... ..	1-4
TONES MENU	
Audio testing ... ..	3-39
Duplex testing ... ..	3-33
Receiver testing ... ..	3-25
Transmitter testing ... ..	3-11
Transmitter frequency adjustment	3-18
TRANSMITTER MONITORING ... ..	3-79
Operation ... ..	3-81
TRANSMITTER TESTING	
DCS operation ... ..	3-62
DTMF operation ... ..	3-59
Operation ... ..	3-7
Sequential tones operation ... ..	3-48
Unpacking and repacking ... ..	2-1

## LIST OF TABLES

Table	Page
3-1 Sequential tone standards ... ..	3-49
3-2 Error codes for RF counter to RF signal generator frequency test ...	3-73
3-3 Error codes for RF power meter to RF generator power test ... ..	3-73
3-4 Error codes for modulation frequency and level tests ... ..	3-74

## LIST OF FIGURES

Fig.		
1-1	Radio Communications Test Set 2955A ... ..	1-2
2-1	GPIB interconnections ... ..	2-4
2-2	GPIB connector contacts ... ..	2-5
2-3	ACCESSORY socket contacts ... ..	2-6
3-1	Front panel ... ..	3-2
3-2	Rear panel... ..	3-4
3-3	AF generator controls and connectors ... ..	3-8
3-4	RF power meter controls and connectors ... ..	3-12
3-5	Modulation meter controls and connectors ... ..	3-14
3-6	Distortion meter controls and connectors ... ..	3-16
3-7	RF generator controls and connectors ... ..	3-20
3-8	AF voltmeter controls and connectors ... ..	3-27
3-9	Distortion meter controls and connectors ... ..	3-29
3-10	Duplex testing controls and connectors ... ..	3-31
3-11	AF generator controls and connectors ... ..	3-36
3-12	AF voltmeter controls and connectors ... ..	3-41
3-13	Distortion meter controls and connectors ... ..	3-43
3-14	Controls and connectors for signalling codes testing ... ..	3-46
3-15	HELP ON TESTING operating summaries ... ..	3-69
3-16	Switches on the GPIB interface unit set to the talk and listen mode and to address 6 (2 + 4) ... ..	3-76
3-17	Example of the printout for a transmitter test ... ..	3-78
3-18	Transmitter monitoring controls and connectors ... ..	3-79
4-1	Signal generator block diagram ... ..	4-2
4-2	AF voltmeter block diagram ... ..	4-2
4-3	AF generator block diagram ... ..	4-3
4-4	RF power meter block diagram ... ..	4-3
4-5	Modulation meter block diagram ... ..	4-4
4-6	Distortion meter block diagram ... ..	4-6



# NOTES