



HAKKO 702

REWORK SYSTEM

Rework System

Instruction Manual

Thank you for purchasing the HAKKO 702 Rework System.
This manual describes the use and maintenance of the HAKKO 702.
Please read it before using the unit. After reading the manual,
keep it in a safe place for future reference.



CAUTION

Before Plugging In!

The automatic blowing function will start sending air when you connect the power plug to power source.
REMOVE the pump shipping screw (M5×10, red) from the bottom of the 702 station before using it. Leaving the screw in place will cause serious problems. Be sure to SAVE THIS SCREW!
REPLACE the pump shipping screw (M5×10, red) into the bottom of the 702 station before transporting it. Leaving the screw out will cause serious problems.

Table of contents

Packing List	1
Specifications, Safety Instructions	2
Part Names.....	3-4
Operation -	
Instructions for Soldering.....	5-6
Instructions for Desoldering.....	7-9
Instructions for S.M.D. Rework.....	10-15
Maintenance.....	16-19
Calibration/Replacement/Optional Parts...	20-22
Parts List (Station).....	23-24
(Iron).....	25-28
Wiring.....	29-30

Packing List

Please check to make sure that all the items listed below are included in the HAKKO 702 package.

Station.....	1	Spring Filter.....	3
Soldering Iron 900S-ESD.....	1	Ceramic Paper Filter (L).....	4
Soldering Iron 900M-ESD.....	1	Ceramic Paper Filter (S).....	2
Desoldering Iron (HAKKO 807).....	1	Cleaning Pin for Ø1.0mm(0.04in.) Nozzle...1	
Iron Holder.....	2	Cleaning Pin for Heating Element.....	1
Holder (For SMD Rework Iron).....	1	Cleaning Pin Holder.....	1
Nozzle Tray.....	1	Cleaning Drill (for ø1.0mm [0.04in.] nozzle)..1	
Spanner.....	1	Cleaning Brush.....	1
Filter Pipe(with a Filter Holder, Spring Filter & Ceramic Paper Filter(L).....	1	FP Pick Up (With S/L wire).....	1
		Silicone Grease.....	1
		Instruction Manual.....	1

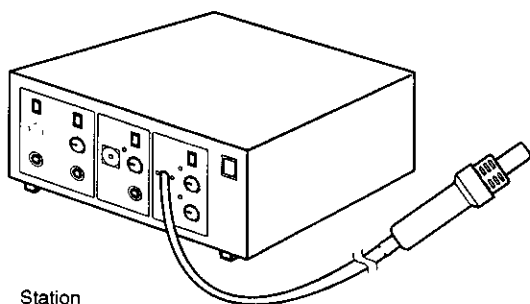

Station

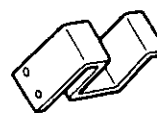

Holder (For S.M.D.Rework Iron)

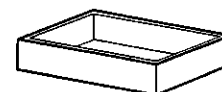

Nozzle Tray

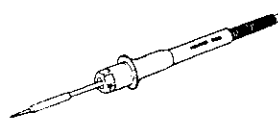

Soldering Iron 900S-ESD

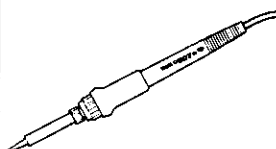

Soldering Iron 900M-ESD

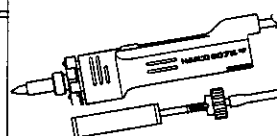

Desoldering Iron 807

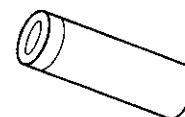

Filter Pipe

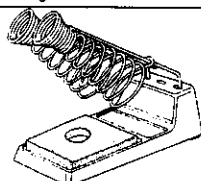

Iron Holder (For Soldering Iron)

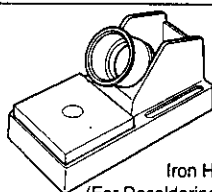

Iron Holder (For Desoldering Iron)

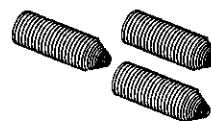

Spring Filter

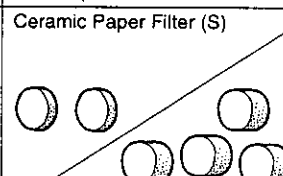

Ceramic Paper Filter (S)

Ceramic Paper Filter (L)



Cleaning Pin for Ø1.0mm (0.04in.) Nozzle

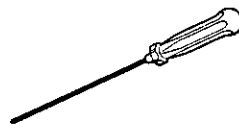

Cleaning Pin for Heating Element

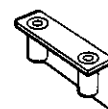

Cleaning Pin Holder

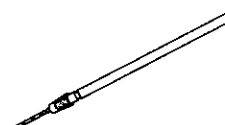

Cleaning Drill for ø1.0mm (0.04 in.) Nozzle



Spanner(For Desoldering Iron)

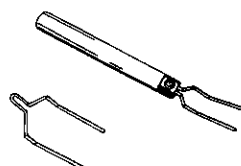

FP Pick Up (With S/L wire)

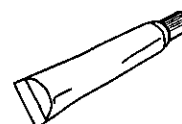

Silicone Grease

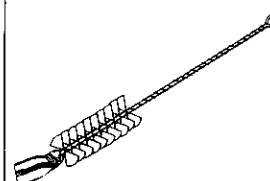

Cleaning Brush

Specifications

Name		HAKKO 702
Power Consumption		500W
Station		
Soldering	Output Voltage	24V AC
	Temperature	200-480°C(392-896°F)
	Temperature Control	±0.5°C(±0.9°F) of tolerance at idling time
Desoldering	Output Voltage	24V AC
	Vacuum Generator	Vacuum Pump, Double Cylinder Type
	Vacuum Pressure	600mmHg (24in. Hg)
	Suction Flow	12ℓ/min
	Motor Output	12W
SMD Rework	Temperature	350-450°C(662-842°F)
	Output Voltage	120V AC
	Pump	Diaphragm Pump
	Capacity	23ℓ/min (max.)
	Temperature	100-420°C(212-788°F)Use A1126
Dimensions		400(W)×295(D)×193(H)mm (15.8×11.6×7.6in)
Weight		10.3kg (22.8lbs)(w/o cord)

Soldering Iron

Name	900S-ESD	900M-ESD
Power Consumption	24V AC-50W	
Tip to Ground Resistance	Under 2 Ω	
Tip to Ground Potential	Under 2mV	
Heating Element	Ceramic	
Cord Assembly	1.2m (4ft.)	
Total Length (w/o cord)	176mm(7in.)	190mm(7.5in.)
Weight (w/o cord)	25g(0.06lb.)	45g(0.1lb.)

Desoldering Iron

Name	HAKKO 807
Power Consumption	24V AC-60W
Tip to Ground Resistance	Under 2 Ω
Tip to Ground Potential	Under 2mV
Heating Element	Ceramic
Cord Assembly	1.2m(4ft.)
Total Length (w/o cord)	205mm(8.07in.)
Weight (w/o cord,hose)	160g (0.35lb.)

SMD Rework Iron

Power Consumption	AC 260W
Total Length (w/o cord)	196mm(7.71in.)
Weight (w/o cord)	120g(0.26lb.)

Safety Instructions



Automatic Blowing Function

Please note the unit will automatically blow air after following operations. This will stop in about 1 minute.

- Connecting the plug.
- Turning on/off the power switch.
- Turning off the switch for SMD Rework.

Before Plugging In!

The automatic blowing function will start sending air when you connect the power plug to power source. So be sure to remove the pump securing screws (M5x10 marked red) from the bottom of the station. Failure to do so may result in serious problem.

After Using

After turning off the switch for SMD Rework and power switch the unit will automatically blow air through the pipe for a short periods of time. Do not disconnect the plug during this cooling process.

High Temperature

The tip/nozzle temperature can reach as high as around 400°C (752°F) when the power switch is on. Since mishandling may lead to burns and fire, be sure to comply with the following precautions.

- Do not touch metallic parts near the tip/nozzle.
- Do not use the product near flammable items.
- Advise other people in the work area that the unit can reach a very high temperature and should be considered potentially dangerous.
- Turn the power off while taking breaks and when you are finished using it.
- Before replacing parts or storing the unit, turn the power off and allow the unit to cool to room temperature.

Be sure to comply with the following precautions. Failing to do so may lead to personal injury or damage to the unit.

- Do not use the unit for applications other than soldering or desoldering.
- Do not rap the iron against the work bench to shake off residual solder, or otherwise subject the iron to severe shocks.
- Make sure to use only genuine HAKKO replacements parts.
- Turn the switch off before connecting or disconnecting the soldering/desoldering iron connecting cord from the cord receptacle on the station.

Part Names

Part Names

●Station

DESOLDER

Vacuum Outlet Cap

Set the Ceramic Paper Filter(S)(No.A1009).
Connects with the hose of
Desoldering Iron 807.

Power Lamp for Desoldering

Lights up when the Switch for Desolder is turned to on.

Switch

Temp. Control Knob

Receptacle

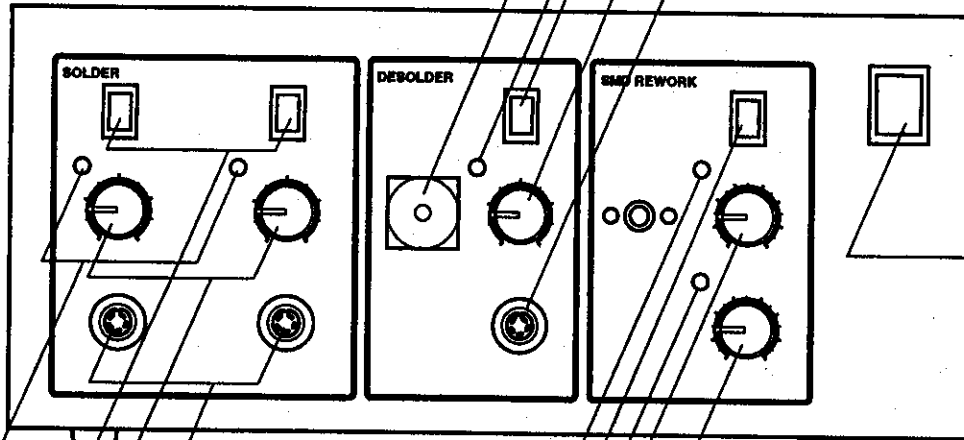

Power Switch

After turning on the
Power Switch, the
automatic blowing
function will start
sending air through
the pipe.

Receptacle

Temp. Control Knob

Switch

LED Lamp

Lamp turns on and off
when the Tip reaches
the set temp.

SOLDER

Switch

Air Flow Lamp

Temp. Control Knob

Air Flow Control Knob

Heater Lamp

Lamp turns on and off when the Heating Element
gets electricity.

SMD REWORK

Fuse Holder

Power Cord

After connecting into the power supply,
the automatic blowing
function will start sending air.

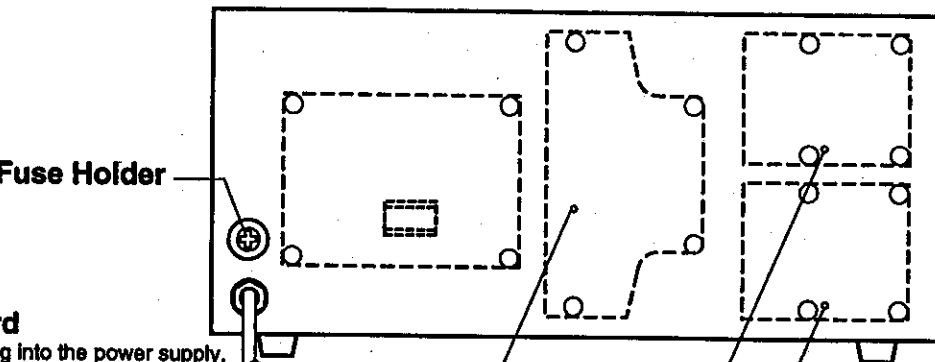

CAL(Calibration for Soldering Iron)

Used for calibrating the temperature.

CAL(Calibration for Desoldering Iron)

Used for calibrating the temperature.

● Iron

SMD Rework Iron

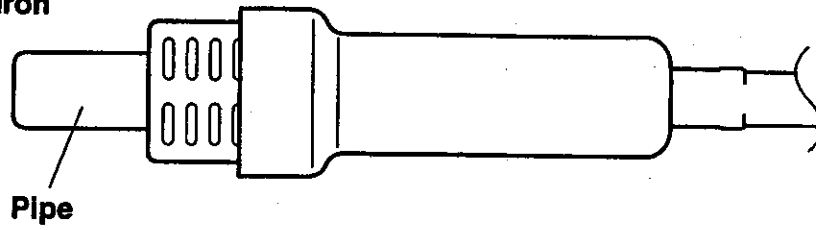

Desoldering Iron HAKKO 807

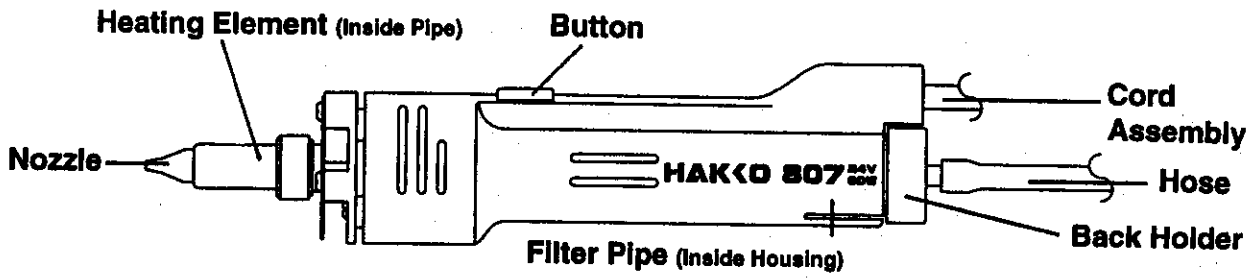

Soldering Iron 900M-ESD

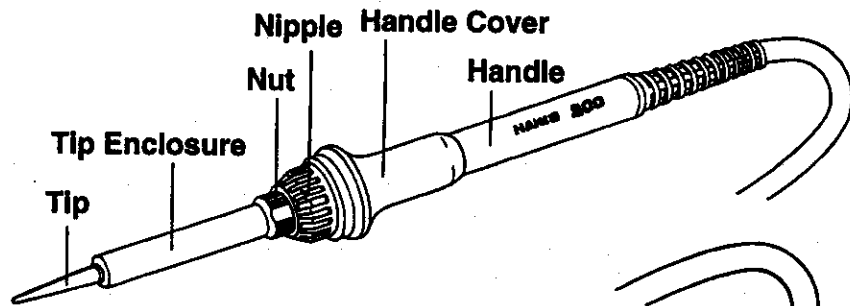

Soldering Iron 900S-ESD

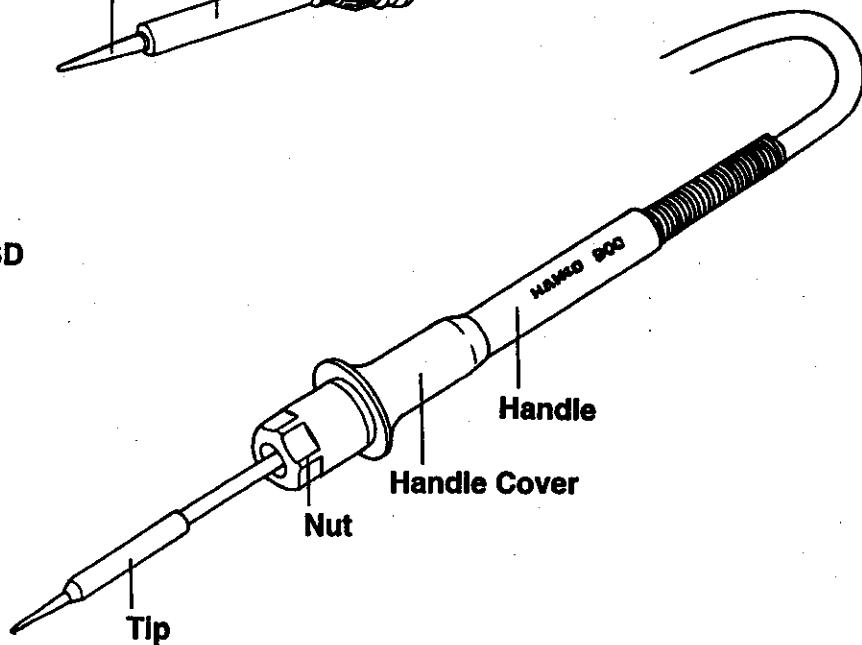

Operation/Instructions For Soldering

Preparation

1. Assemble the Iron Holder for Soldering Iron 900M and 900S. (HAKKO 631-04)

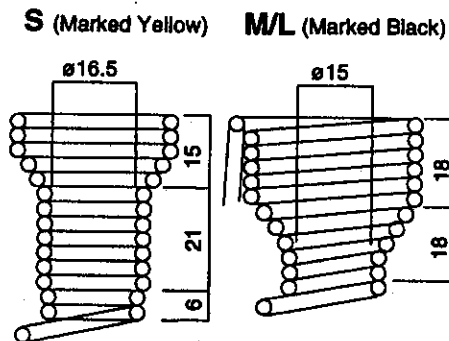

2. Connections

Operation

1. Plug the Power Cord into the Power Supply, and turn on the Power Switch.

2. Temp. Setting

- Set the Spring Iron Holder in the Iron Holder Base.
- There are two sizes of Spring Holder, for 900M/L and 900S. Select the appropriate size.

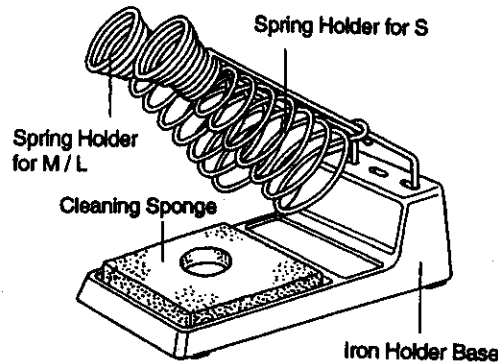

- Dampen the Cleaning Sponge with water and then squeeze it until it is moist.
- Connect the Cord Assembly to the Receptacle. **Caution; Be sure to turn off the Switch for Solder before connecting or disconnecting the Soldering Iron. Failing to do so may damage P.W.B.**
- Each Soldering has been tested and calibrated at the factory. Connect the A-Iron to the A-Iron Receptacle and the B-Iron to the B-Iron Receptacle.

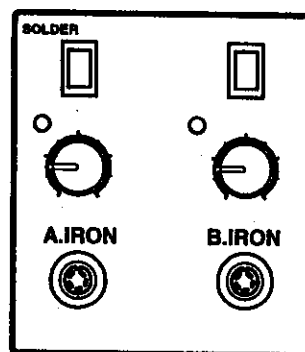

Note: HAKKO 900L Soldering Iron featuring a large tip size also can be used with 702 Station. (See Page 20.)

- Set the Temp. Control Knob to your desired temp. and turn on the Switch for Solder. Heater Lamp turns on and off when the Tip temp. reaches to the figure you set. Now you can start the soldering work.

3. Tip Care and Use

- **Tip Temperature**
High soldering temperature can degrade the Tip. Use the lowest possible soldering temperature. The excellent thermal recovery characteristics ensure efficient and effective soldering even at low temp. This also protects the soldered items from thermal damage.
- **Cleaning**
Clean the Tip regularly with a cleaning sponge as oxides and carbides from the solder and flux can form impurities on the Tip. These impurities can result in defective joints or reduce the Tip's heat conductivity.
- **Not in Use**
Never leave the soldering iron sitting at high temp. for long periods of time as the Tip's solder plating will become covered with oxide, which can greatly reduce the Tip's heat conductivity.
- **After Use**
Wipe the Tip clean and coat the Tip with fresh solder. This helps prevent Tip oxidation.

Inspect and Clean the Tip

1. Set the temperature to 250°C (482°F).
 2. When the temp. stabilizes, clean the Tip with the Cleaning Sponge and check the condition of the Tip.
 3. If there is black oxide on the solder plated portion of the Tip, apply new flux contained solder and wipe the Tip on the Cleaning Sponge. Repeat until the oxide is completely removed. Coat with new solder.
- ⚠ Never file the Tip to remove oxide.
4. If the Tip is deformed or heavily eroded, replace it with a new one.

Operation/Instructions For Desoldering

Preparation

1. Assemble the Iron Holder for Desoldering Iron 807. (No. C1316)

⚠ CAUTION

The sponges are compressed. They will swell when moistened with water. Before using the unit, dampen the cleaning sponge with water and squeeze it dry. Failure to do so will reduce the life of the nozzle.

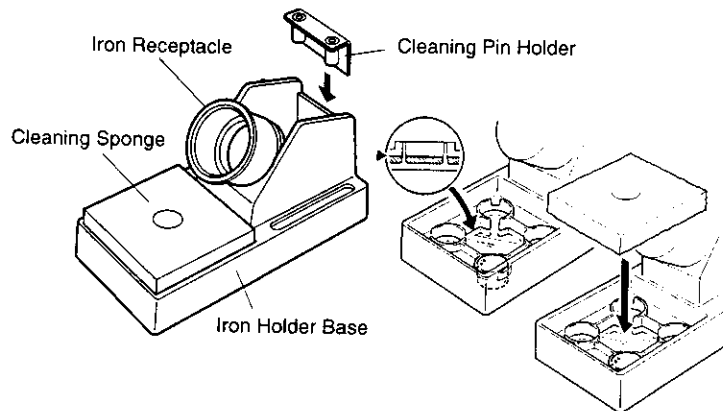

- Dampen the capillary sponge (the small round sponge) with water and squeeze it dry. Place it in one of the four round openings in the iron holder base.
- Add water to approximately the level shown in the illustration. Put the cleaning sponge on the base, as shown. The capillary sponge will absorb water from the reservoir and, by capillary action, transfer water to the cleaning sponge, thus keeping it moist at all times.

Note: The cleaning sponge may be used by itself; if it is, it is not necessary to use the capillary sponge or add water to the reservoir. Simply dampen the sponge, squeeze it dry, and place on the iron holder base.

- Place the cleaning pin holder on the iron holder base, as shown in the illustration above.

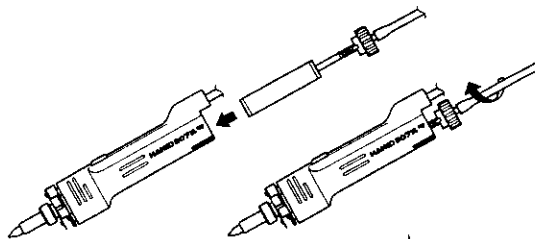

2. Assemble the Desoldering Iron

Insert the filter pipe (with a filter holder, spring filter and ceramic paper filter [L]) into the housing. Push and turn the back holder clockwise.

3. Connections

- Connect the Desoldering Iron to the Station.
Caution: Be sure to turn off the Switch for Desolder before connecting or disconnecting the Desoldering Iron. Failing to do so may damage P.W.B.
Insert the 6-pin connecting plug into the Receptacle on the Station.
Lock the plug by turning the plug's outer ring clockwise.
Connect the Hose to the Vacuum Outlet Cap.
- Place the Desoldering Iron in the Iron Holder.

Operation

1. Plug the power cord into the Power Supply, and turn on the Power Switch. Turn on the Switch for Desolder.

2. Set the temperature.

Note: Always set the temperature to as low as possible for the work being done.

- To more precisely set the temperature, measure the temperature at the Nozzle using a soldering iron thermometer and adjust the Temperature Control Knob accordingly.

3. Clean the tip of the Nozzle.

- Keep the solder-plated section of the Nozzle a shiny white by coating it with a small amount of solder.

4. Melt the solder.

- Apply the Nozzle to the soldered part and melt the solder.

Note: Never allow the Nozzle to touch the board itself.

- Confirm that the solder is melted.

5. Absorb the solder.

- After confirming that the solder is completely melted, absorb the solder by pushing the button on the Iron.

6. Problems during Desoldering.

- If solder remains, resolder the component and repeat the desoldering process.

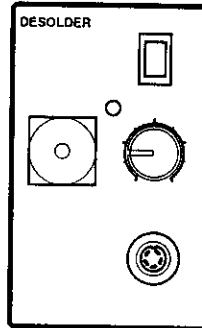

Desoldering

After turning the Switch to ON, wait 3 minutes before beginning desoldering.

- The temperature can be adjusted between 350~450°C (662~842°F) with Temperature Control Knob. This Unit has excellent thermal recovery to operate with lower temperature than conventional desoldering tool.

We recommend the HAKKO 191/192 thermometer for measuring the Nozzle temperature.

If the tip of the Nozzle is coated with oxide, the Nozzle's heat conductivity will be lowered. Coating the tip with a small amount of fresh solder ensures maximum heat conductivity.

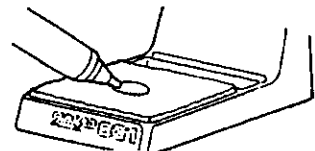

Wipe away any oxide or old solder from the Nozzle using the hole in the center of the sponge.

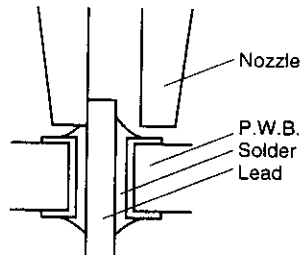

Note: To confirm that all the solder is melted, observe the inside of the hole and the backside of the P.W.B. If this is difficult to do, try slowly moving the lead with the Nozzle if the lead moves, the solder is melted.

Note: Never move the lead by force. If it doesn't move easily, the solder isn't yet fully melted.

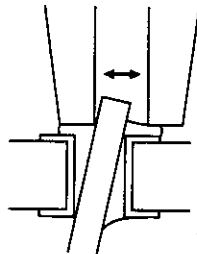

Note: Never leave any solder remaining inside the hole in the P.W.B.

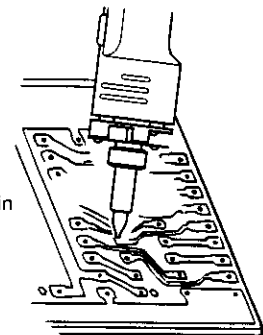

Slowly move the lead with the nozzle.

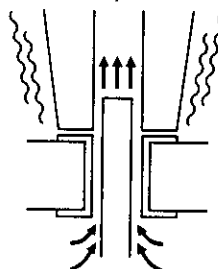

Absorb the solder by slowly moving the lead back and forth with the tip of the nozzle.

Problems during Desoldering

A. The solder in the junction is not sufficiently melted.

A. The solder in the junction is not sufficiently melted.

● Temperature is not high enough.

The following parts require a greater heat capacity to desolder.

- Multi-layer P.W.B.s, power supplies, ground planes in through-hole P.W.B.s, high-capacity transistors, triacs with heat radiation fins, tuner P.W.B. ground wires, and largescale transformer terminals.

Use a preheating oven or heating gun to heat the P.W.B. to a temperature that won't damage the board or its components [Between 70°C (160°F) and 80°C (180°F)], then desolder. Do not increase the temperature of the Iron by recalibration as this may damage the P.W.B. board and its components.

● Nozzle is worn out.

- When the Nozzle begins to wear out, the heating efficiency begins to decline. Check the Nozzle. If the solder plating is damaged (p.16), or the Nozzle is eroded (p.16), replace the Nozzle.

B. Suction power is dropping.

B. Suction Power is dropping.

- Replace the Filters, and clean the Nozzle and the inside of the Heating Element. (refer to p.16,17)

● Air is leaking from the vacuum system.

Check the air-tightness of the following parts and replace any that are worn.

- | | |
|---|-----------------------|
| a. Contact point of the Nozzle and Heating Element. | c. Hose. |
| b. Filter Pipe. | d. Vacuum Outlet Cap. |

Post-operation Maintenance

To ensure a long service life, always perform the maintenance procedures on page 16~17 immediately after using the HAKKO 702 unit.

- Remove all solder from the inside of the Nozzle and the Heating Element.

- Clean the Tip of the Nozzle with the Cleaning Sponge, then coat the Tip with a fresh layer of solder to protect the solder plating.

Operation/Instructions For SMD Rework

Preparation

1. Attach Holder for SMD Rework Iron.

- Attach the Iron Holder with supplied screws as shown.

2. Select the FP Pick-up Wire that matches the size of the IC.

- The FP Pick-up has an S wire (14mm) attached to it, but an L wire (30mm) may be necessary, depending on the size of the IC. Choose the appropriate wire for the IC.

3. Select the Nozzle that matches the size of the IC.

*Nozzle Tray is for placing the optional Nozzle.

- Attach the Nozzle when both the Pipe and the Nozzle are cool. Should either be warm, check to make sure that the Temperature Control Knob is set to 1.

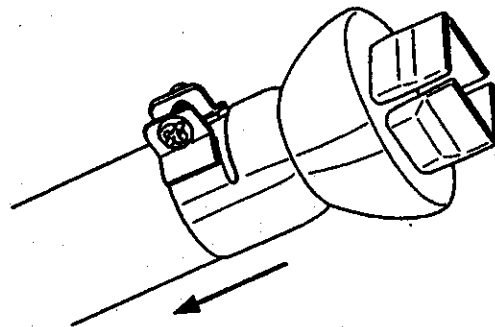
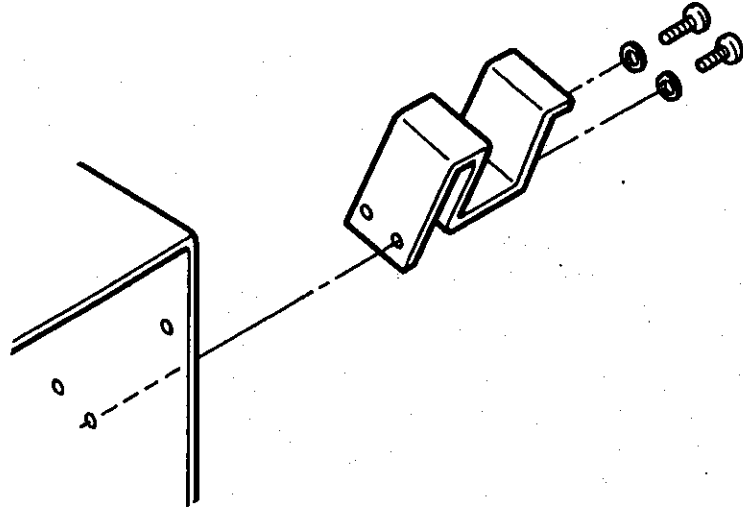

Operation

1. Connection

- Plug the Power Cord into the power supply, and turn the Power Switch on.
- After connecting the plug into power source, the automatic blowing function will start sending air. The Power Switch may be turned on at any time while the automatic blowing function is operating.

2. Turn on the Switch for SMD Rework Iron.

Once the Switch is turned to on, the Heating Element begins to warm up.

CAUTION

Thermal Protector.

For safety, power is automatically shut off to the heating element should the unit exceed a certain temperature.

Once the temperature has dropped to a safety level, power is automatically turned on.

Turn off the Switch and cool the iron. After that, to continue operation, reduce the temperature setting or increase the Air Flow. Should the Thermal Protector be tripped and you do not wish to continue the operation or if you leave that place, be sure to turn the Power Switch off.

QFP Desoldering

1. Adjust the Air Flow and Temperature Control Knobs.

- After adjusting the Air Flow and Temperature Control Knob, wait for the temperature to stabilize for a short period of time. Refer to the temperature distribution chart. For your reference, we recommend you to adjust the temperature around 300 to 350°C (572~662°F).

2. Place the FP Pick-up under the IC lead.

- Slip the FP Pick-up Wire under the IC lead. If the width of the IC does not match the size of the FP Pick-up, adjust the width of the wire by suppressing the wire.

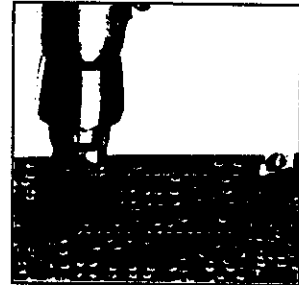

3. Melt the solder.

- Hold the iron so that the Nozzle is located directly over, but not touching the IC, and allow the hot air to melt the solder. Be careful not to touch the leads of the IC with the Nozzle.

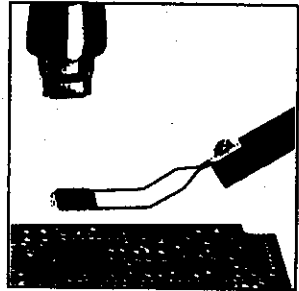

4. Remove the IC.

- Once the solder has melted, remove the IC by lifting the FP Pick-up.

5. Turn the Switch for SMD Rework Iron.

- After the Switch is turned off, an automatic blowing function begins sending cool air through the pipe in order to cool both the heating element and the handle. So do not disconnect the plug during this cooling process. In case you don't use the unit for a long time, disconnect the plug.

6. Remove any remaining solder.

- After removing the IC, remove remaining solder with a wick or desoldering tool.

QFP Soldering**1. Apply the solder paste.**

- Apply the proper quantity of solder paste and install the SMD on the P.W.B.

2. Preheat SMD.

- Refer to the photo to preheat SMD. (Fig.I)

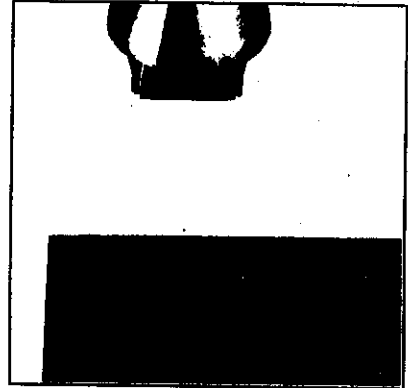

Fig. I

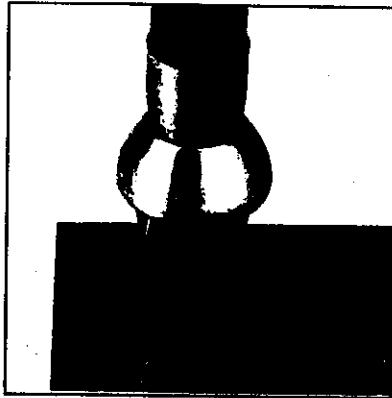

Fig. II

3. Soldering.

- Heat the lead frame evenly. (Fig.II)

4. Washing.

- When soldering is completed, wash away the flux.

Note: While there are merits by hot air, it's also possible to cause the defects such as solder balls, solder bridges. We recommend you to examine the conditions of soldering sufficiently.

Temperature Distribution Chart

Test criteria: Measured at the point 3mm from the Nozzle by recorder.
 (A1124~A1129) Room Temperature 23°C (73.4°F).

A1124 [Single $\phi 2.5$ (0.09 in)]

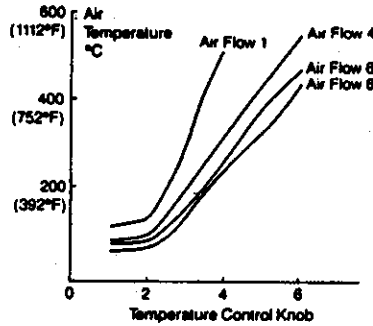

A1125 (QFP 10 x 10)

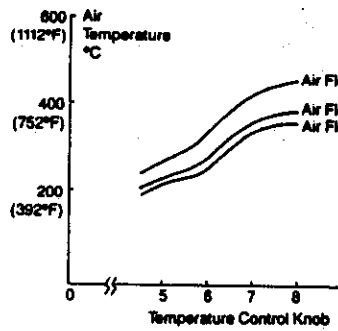

A1126 (QFP 14 x 14)

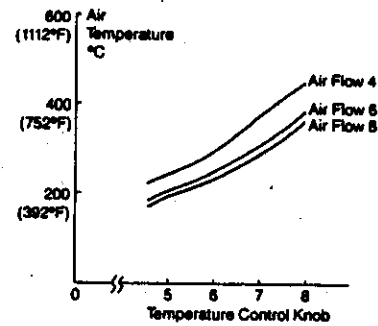

A1127 (QFP 17.5 x 17.5)

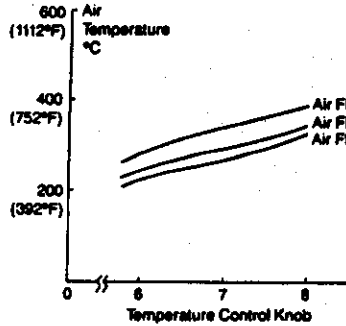

A1128 (QFP 14 x 20)

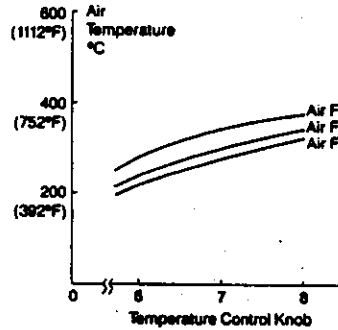

A1129 (QFP 28 x 28)

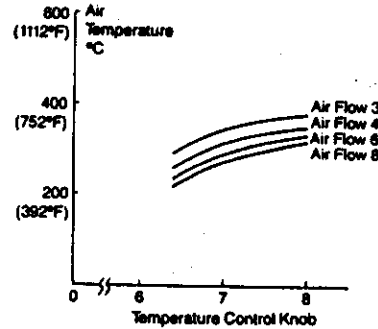

Test criteria: (A1130~A1142) Room Temperature 21°C (67°F).

A1130 [Single $\phi 4.4$ (0.17 in)]

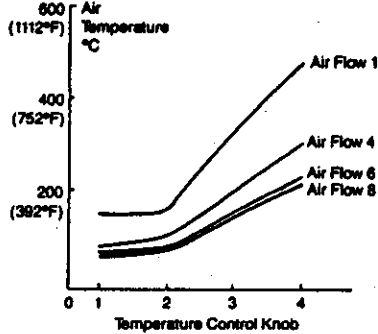

A1131 (SOP 4.4 x 10)

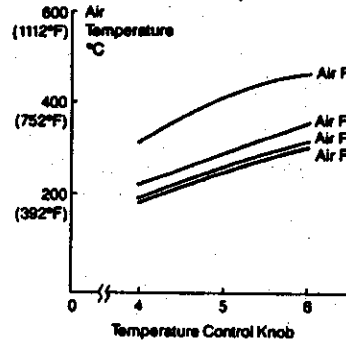

A1132 (SOP 5.6 x 13)

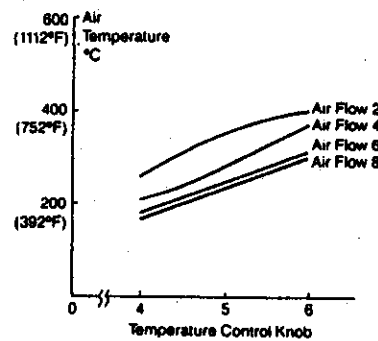

A1133 (SOP 7.5 x 15)

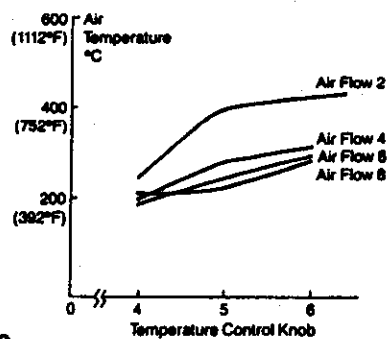

A1134 (SOP 7.5 x 18)

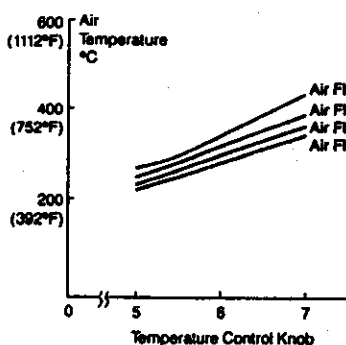

**A1135 (PLCC 17.5 x 17.5)
(44 Pins)**

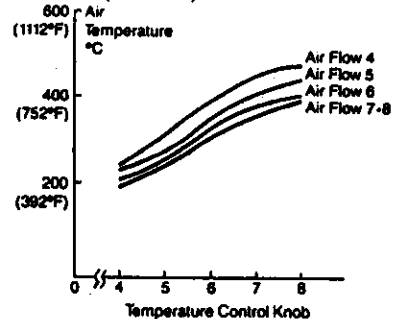

**A1136 (PLCC 20x20)
(52 Pins)**

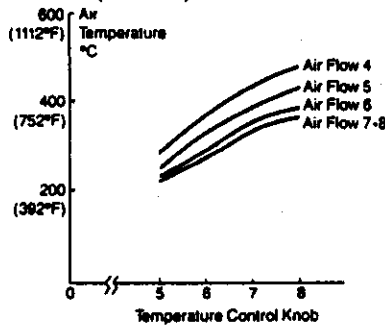

**A1137 (PLCC 25x25)
(68 Pins)**

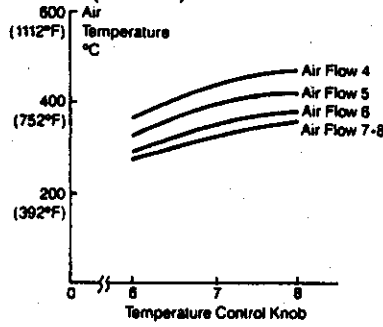

**A1138 (PLCC 30x30)
(84 Pins)**

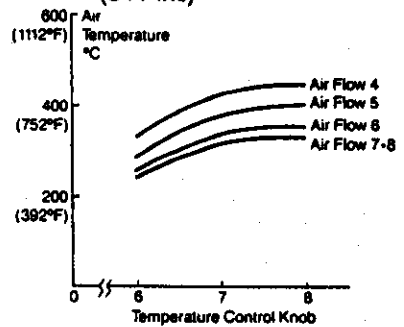

**A1139 (PLCC 7.3x12.5)
(18 Pins)**

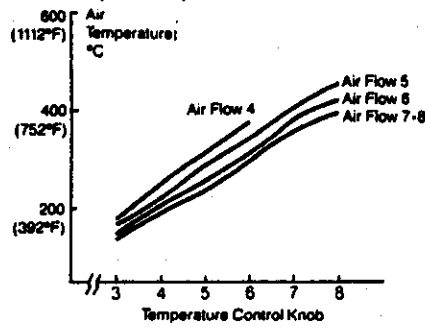

**A1140 (PLCC 11.5x11.5)
(28 Pins)**

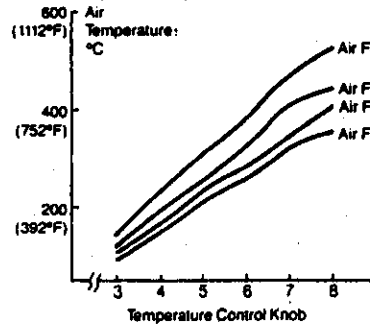

**A1141 (PLCC 11.5x14)
(PLCC 32 Pins)**

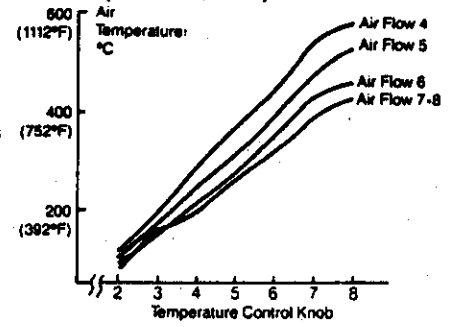

A1142 (Bent Single 1.5x3)

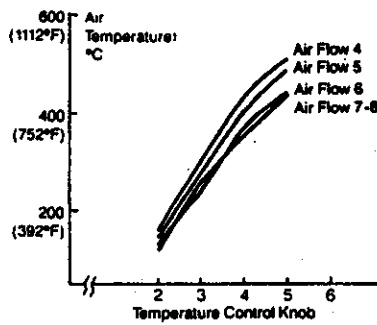

Test criteria: (A1180-A1192,A1203,A1214,A1215)
Room Temperature 24°C (75.2°F).

**A1180
BQFP 17x17 (0.67x0.67)**

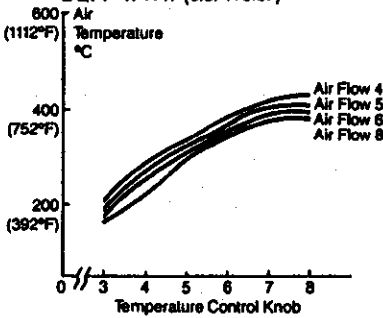

**A1181
BQFP 19x19 (0.75x0.75)**

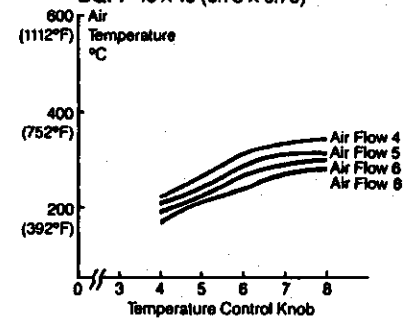

**A1182
BQFP 24x24 (0.94x0.94)**

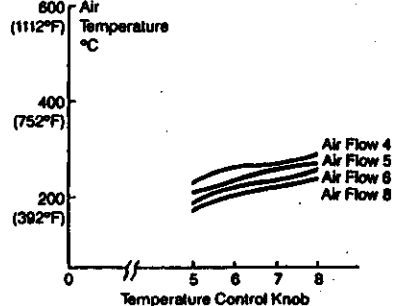

**A1183
SOJ 15x8 (0.59x0.31)**

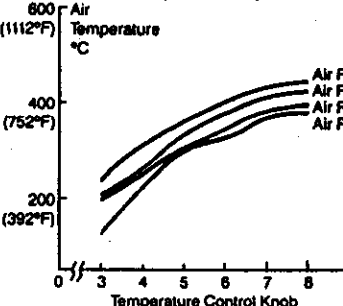

**A1184
SOJ 18x8 (0.71x0.31)**

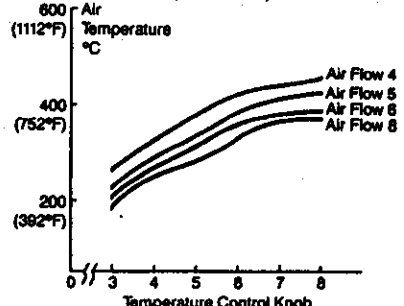

Temperature Distribution Chart

Test criteria: (A1258) Room Temperature 28°C (82.4°F).

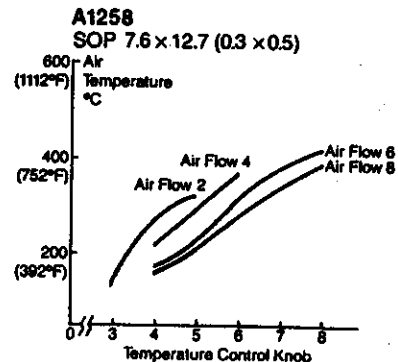
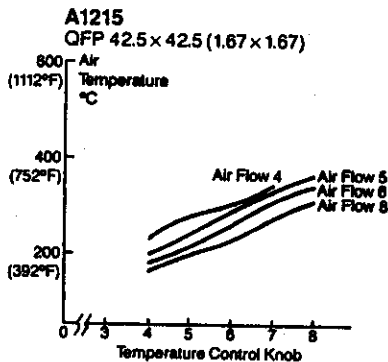
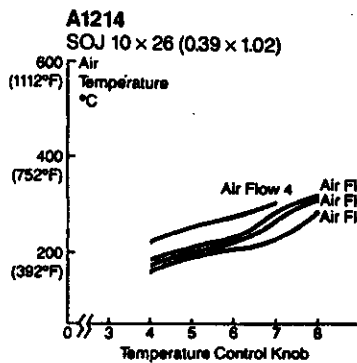
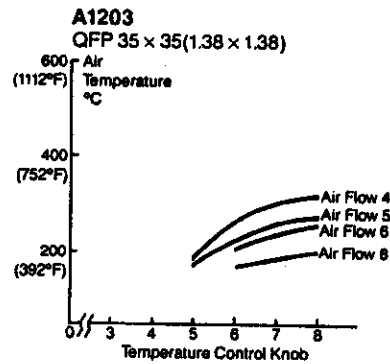
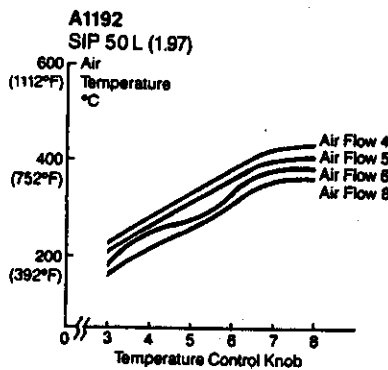
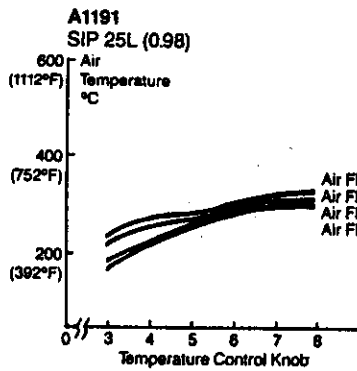
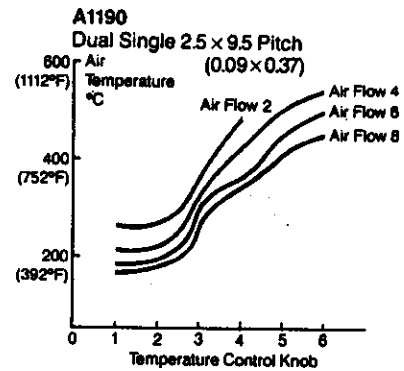
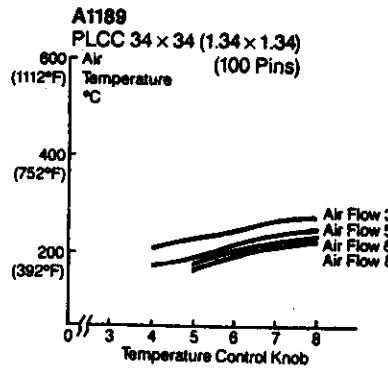
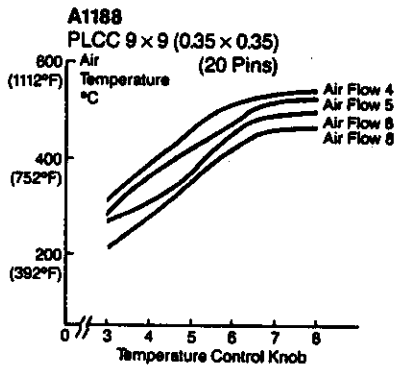
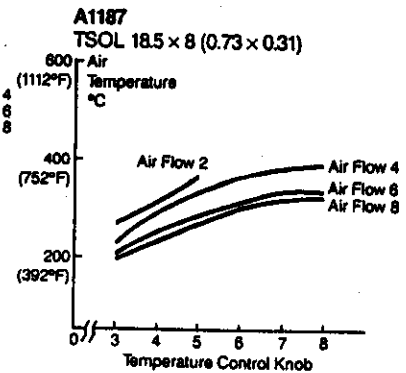
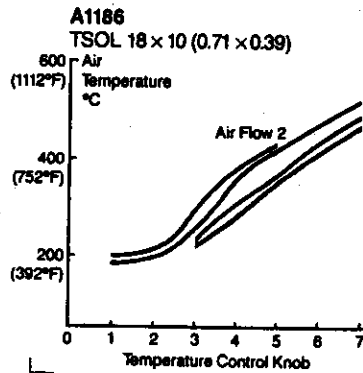
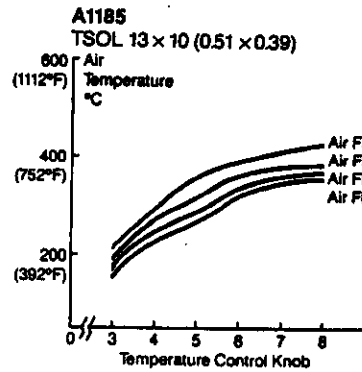

Maintenance (Desoldering Iron)

Efficient desoldering depends upon the temperature, and the quality and quantity of the solder and flux. Perform the following service procedures as dictated by the conditions of the Iron usage.

The Desoldering Iron will be extremely hot. During maintenance, please wear gloves and work carefully.

Servicing the Desoldering Iron

1. Inspect and clean the Nozzle.

- Plug in the power cord, turn the Power Switch On and let the Nozzle heat up.
- Clean out the hole of the Nozzle with the Nozzle Cleaning Pin. If the Nozzle Cleaning Pin does not pass through the Nozzle, use the Optional Cleaning Drill.

Note: The Cleaning Pin will not pass through the Nozzle until the solder inside the Nozzle is completely melted.

- Check the condition of the solder plating, surface and inside hole of the Nozzle. Recoat the Tip with fresh solder.
- If either is worn or eroded, or the inside diameter seems unusually wide, replace the Nozzle.

Note: The inside hole and the surface of the Nozzle is plated with a special alloy. Should this alloy become eroded by high temperature solder, the Nozzle will not be able to maintain the proper temperature.

- If the Cleaning Pin and Cleaning Drill does not pass through the hole in the Nozzle, replace the Nozzle.

Cleaning with the Nozzle Cleaning Pin.

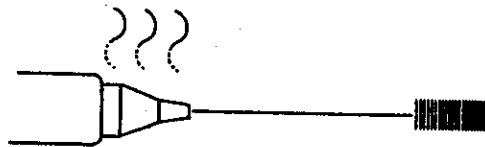

The Cleaning Pin passes completely through the hole.

Cleaning with the optional Cleaning Drill.

• Before Cleaning



Insert the Bit while turning it clockwise.

• After Cleaning

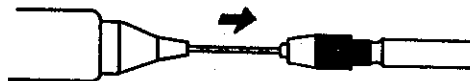

Pull the Drill Bit out straight without turning it.

Caution:
If the Cleaning Drill is forced into the Nozzle, the Drill Bit could break or be damaged.

Caution:
Please use the proper sized Cleaning Pin or Cleaning Drill for the Nozzle diameter.

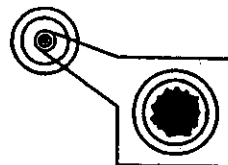
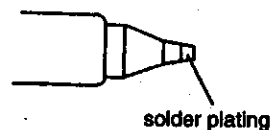

Diameter of hole is widened through erosion.

Note:
Unfortunately, it is often difficult to observe this condition, therefore, if desoldering efficiency goes down and all other parts appear to be OK, the Nozzle is probably eroded and should be replaced.

2. Disassemble the Heating Element.

Caution: the Heating Element is very hot during operation.

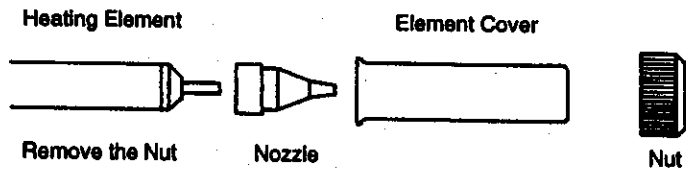

3. Clean out the hole in the Heating Element.

- Be sure the solder in the hole in the Heating Element is completely melted, then clean the hole with the provided Cleaning Pin.

Note: If the Cleaning Pin cannot pass through the hole, replace the Heating Element.

Scrape away all oxidation from the hole in the Heating Element until the Cleaning Pin passes cleanly through the hole.

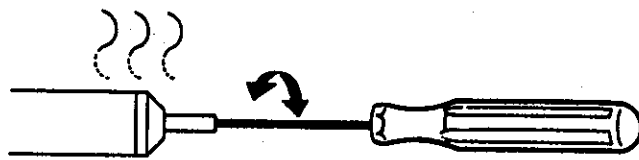

The Cleaning Pin passes cleanly through the hole.

4. Replace the Filters.

- Turn the back holder knob counterclockwise and pull out the Filter Pipe.
- If there is solder in two-thirds of the Spring Filter, replace the Filter.
- If the Ceramic Paper Filter is stiff with flux and solder, replace the Filter.
- Insert the Spring Filter into the Filter Pipe.
- Insert the Ceramic Paper Filter.
- Insert the Back Holder into the Filter Pipe.
- Insert the Filter Pipe into the Main Body and secure it by turning the Back Holder Knob clockwise.

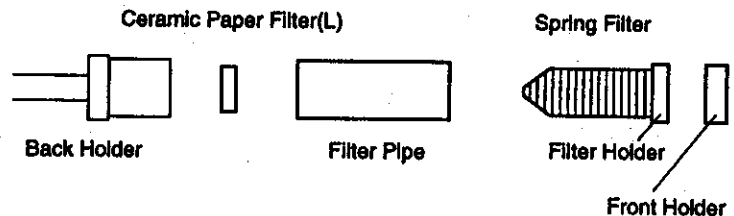

CAUTION

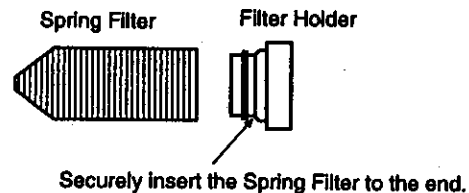

Maintenance (Station)

Cleaning the Inside of the Filter Case

1. Replace the Ceramic Paper Filter.

- Detach the Filter Retainer, being very careful not to let the Valve pop out. Remove the Ceramic Paper Filter and inspect it. If it is stiff with flux, replace it.

2. Clean the Filter Retainer.

- Remove any flux adhering to the Filter Retainer.

3. Clean the Valve.

- Remove any flux adhering to the Valve.

Caution: Do not misplace the white washer that is attached to the Valve.

4. Reassemble the Filter Case.

Caution: Set the Ceramic Paper Filter (S) for Filter Case (Station). Using Ceramic paper Filter (L) in the Filter Case may cause to break or the power to drop.

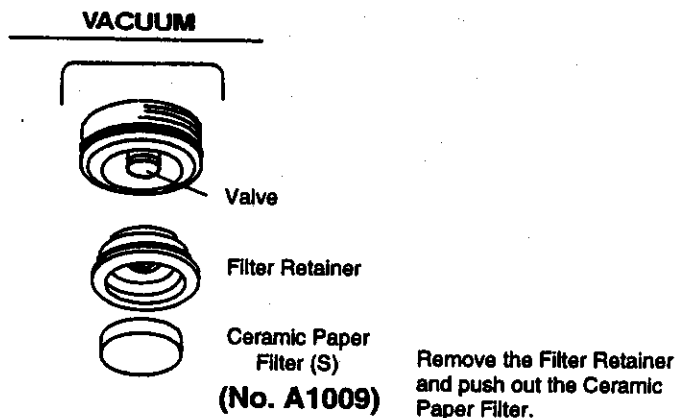

Remove any flux adhering to the Filter Retainer.



Filter Retainer (rear)

Caution:
Use only alcohol for cleaning.
Never use thinner as it may damage the material of the Filter Retainer.

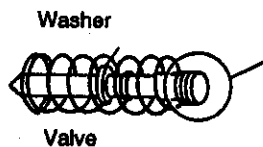

Remove any flux adhering to the Valve.

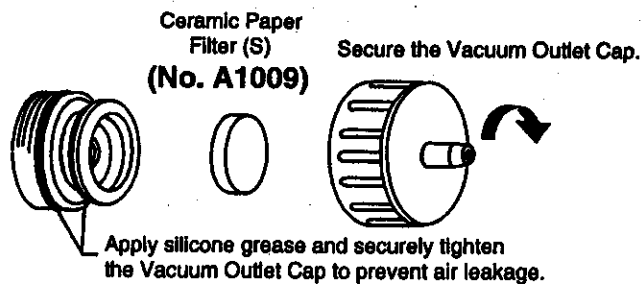

Cleaning the Pump

Caution: Unplug the Power Cord before starting this procedure.

1. Disassemble the Pump Heads.

- Remove the Cover.
- Remove the Pump Head from each side the Pump.

2. Clean the Pump Head.

- Remove the Valve Plate and Fixing Plate.
- Remove any flux adhering to the Plates.

Caution:
If the Fixing Plate is difficult to remove, apply hot air to it to warm it up. Never use excessive force to remove the Plate as it is easy to bend, and a bent Plate will allow air to leak out and reduce solder vacuuming efficiency.

Caution:
Clean the Plates only with alcohol or thinner.

Replace:
If the Valve Plate is bent or stiff, replace it.

- If the Exhaust Filter is dirty, replace it.

3. Assemble the Pump Heads.

- Reassemble the Valve Plate and Fixing Plate.

Caution:
When assembling the Pump, be sure to check for air leaks.

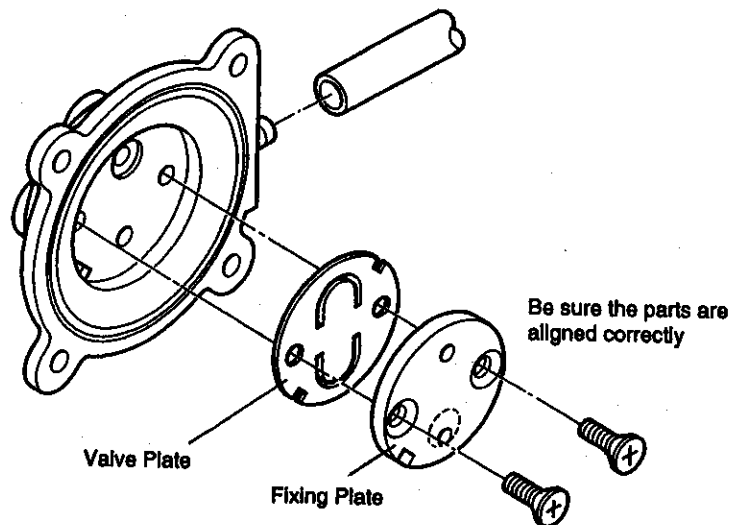
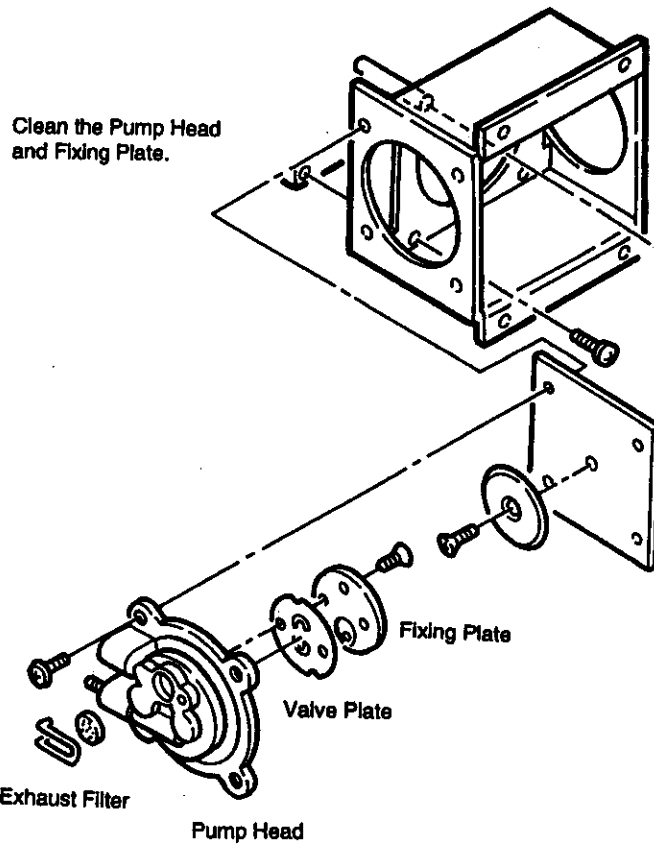

Calibration/Option, Replacement Parts

The 702 unit should be recalibrated after changing the Iron, replacing the Heating Element.

Calibration

1. Connect the plug of Cord Ass'y to the Receptacle of the Station.
2. Set the Temp. Control Knob at 400°C (752°F).
3. Turn the Switch for Solder and Desolder on and wait till the temp. stabilizes.
4. When the temp. stabilizes, use a straight-edge (-) screwdriver to adjust the screw (marked CAL at the rear panel of the station) until the tip thermometer indicates a temperature of 400°C (752°F).
Turn the screw clockwise to increase the temperature and counterclockwise to reduce the temperature.

*We recommend the HAKKO 191/192 thermometer for measuring the Tip / Nozzle temperature.

Replacement Tip for 900S/M

☆The Tip temp. may vary depending on figure. Refer to the chart for the correct adjustment.

Example

When using 900M-T-H at 400°C (752°F).

The gap between standard tip is -20°C (-36°F).

Adjust the Temp. Control Knob at 420°C (788°F).

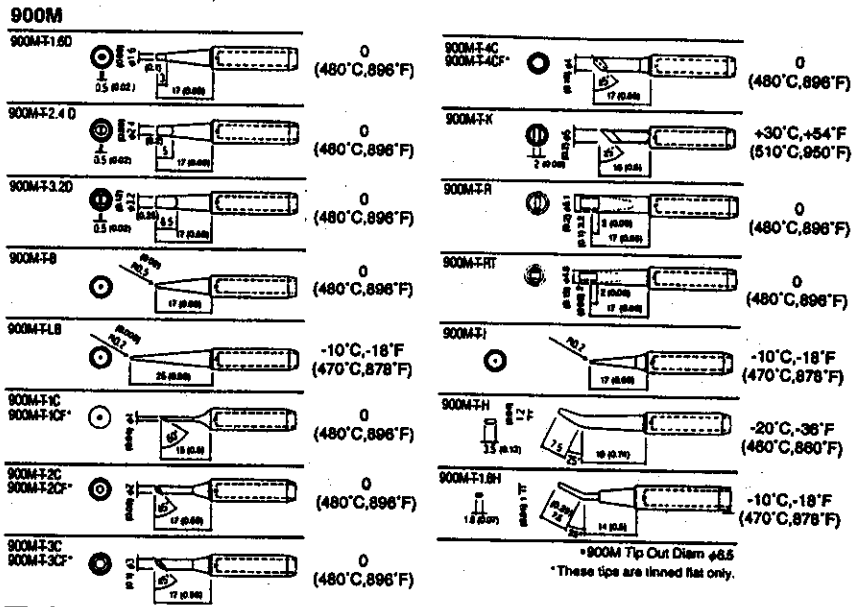

900S

For micro soldering HAKKO recommends The 900S Iron with fine tips.

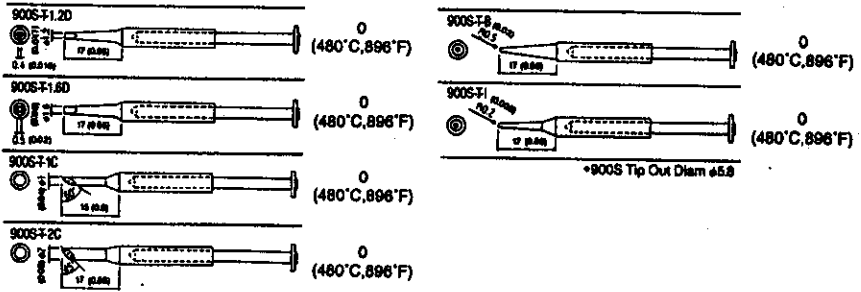

Replacement/Option Parts

Replacement/Option Parts for 807

• Nozzle

Part No.	Part Name/Specification
A1002	Nozzle S ϕ 0.8mm(0.03 in)
A1003	Nozzle S ϕ 1.0mm(0.04 in)
A1004	Nozzle ϕ 0.8mm(0.03 in)
A1005	Nozzle ϕ 1.0mm(0.04 in)
A1006	Nozzle ϕ 1.3mm(0.05 in)
A1007	Nozzle ϕ 1.6mm(0.06 in)

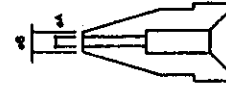
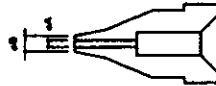

Part No.	ϕ A	ϕ B
A1002	0.8(0.03in)	1.8(0.07in)
A1003	1.0(0.04in)	2.0(0.08in)

Part No.	ϕ A	ϕ B
A1004	0.8(0.03in)	2.3(0.09in)
A1005	1.0(0.04in)	2.5(0.1in)
A1006	1.3(0.05in)	3.0(0.12in)
A1007	1.6(0.06in)	3.0(0.12in)

•Cleaning Pin/Drill

Part No.	Part Name/Specification
B1215	Cleaning Pin for Heating Element
B1086	Cleaning Pin for ϕ 0.8mm(0.03in) Nozzle
B1087	Cleaning Pin for ϕ 1.0mm(0.04in) Nozzle
B1088	Cleaning Pin for ϕ 1.3mm(0.05in) Nozzle
B1089	Cleaning Pin for ϕ 1.6mm(0.06in) Nozzle

•Option

B1302	Cleaning Drill for ϕ 0.8mm(0.03in) Nozzle
B1303	Cleaning Drill for ϕ 1.0mm(0.04in) Nozzle
B1304	Cleaning Drill for ϕ 1.3mm(0.05in) Nozzle
B1305	Cleaning Drill for ϕ 1.6mm(0.06in) Nozzle

Iron Holder/FP Pick Up/ Nozzle Tray

Part No.	Part Name/Specification
B1942	Holder(For SMD Rework Iron)
B1468	Spring Iron Holder M/L
B1469	Spring Iron Holder S
B1671	Spring Iron Holder for 807
A1042	Cleaning Sponge *Old Part No. 609-029
B1470	Iron Holder Base
B1438	FP Pick Up
B1439	FP Pick Up Wire(S)
B1440	FP Pick Up Wire(L)
B1914	Nozzle Tray

Option

Nozzle for SMD Rework Iron

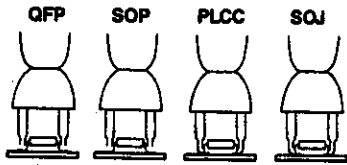





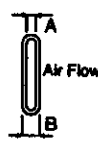



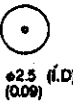





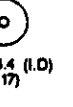

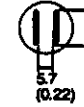
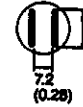

















•Nozzle for SMD Hot Air

mm(inch) *The size in Name/Specification Indicates the size of IC package.



No.	A 0.8(0.03) B 1.8(0.07)	A 1.0(0.04) B 2.0(0.08)
	A1125~A1129 A1131~A1141 A1180~A1188 A1203, A1214 A1215, A1258	

A1124 Single  φ2.5 (I.D.) (0.09)	A1125 QFP 10 × 10 (0.39 × 0.39)  10.2 (0.4) 10.2 (0.4)	A1126 QFP 14 × 14 (0.55 × 0.55)  15.2 (0.6) 15.2 (0.6)	A1127 QFP 17.5 × 17.5 (0.68 × 0.68)  19.2 (0.76) 19.2 (0.76)	A1128 QFP 14 × 20 (0.55 × 0.78)  19.2 (0.76) 21.2 (0.83)	A1129 QFP 28 × 28 (1.1 × 1.1)  28.2 (1.11) 28.2 (1.11)
A1130 Single  φ4.4 (I.D.) (0.17)	A1131 SOP 4.4 × 10 (0.17 × 0.39)  4.8 (0.19) 10.2 (0.4)	A1132 SOP 5.6 × 13 (0.22 × 0.51)  5.7 (0.22) 15.2 (0.6)	A1133 SOP 7.5 × 15 (0.3 × 0.59)  7.2 (0.28) 19.2 (0.76)	A1134 SOP 7.5 × 16 (0.3 × 0.7)  7.2 (0.28) 19.2 (0.76)	A1135 PLCC 17.5 × 17.5 (0.68 × 0.68) (44 Pins)  18.5 (0.73) 18.5 (0.73)
A1136 PLCC 20 × 20 (0.78 × 0.78) (52 Pins)  21 (0.83) 21 (0.83)	A1137 PLCC 25 × 25 (0.98 × 0.98) (68 Pins)  26 (1.02) 26 (1.02)	A1138 PLCC 30 × 30 (1.18 × 1.18) (84 Pins)  31 (1.22) 31 (1.22)	A1139 PLCC 12.5 × 7.3 (0.49 × 0.29) (18 Pins)  9 (0.35) 14 (0.55)	A1140 PLCC 11.5 × 11.5 (0.45 × 0.45) (28 Pins)  13 (0.51) 13 (0.51)	A1141 PLCC 11.5 × 14 (0.45 × 0.55) (32 Pins)  13 (0.51) 15 (0.59)
A1142 Bent Single 1.5 × 3 (0.06 × 0.12)  45° 1.5 (0.06) 3 (0.12)	A1180 BQFP 17 × 17 (0.67 × 0.67)  18.2 (0.72) 18.2 (0.72)	A1181 BQFP 19 × 19 (0.75 × 0.75)  18.2 (0.72) 18.2 (0.72)	A1182 BQFP 24 × 24 (0.94 × 0.94)  24.2 (0.96) 24.2 (0.96)	A1183 SOJ 15 × 8 (0.59 × 0.31)  8 (0.31) 16 (0.63)	A1184 SOJ 18 × 8 (0.71 × 0.31)  10 (0.39) 19 (0.75)
A1185 TSOL 13 × 10 (0.51 × 0.39)  11.9 (0.47) 10 (0.39)	A1186 TSOL 18 × 10 (0.71 × 0.39)  18.2 (0.72) 11.9 (0.47)	A1187 TSOL 18.5 × 8 (0.73 × 0.31)  18.5 (0.73) 10 (0.39)	A1188 PLCC 9 × 9 (0.35 × 0.35) (20 Pins)  11 (0.43) 11 (0.43)	A1189 PLCC 34 × 34 (1.34 × 1.34) (100 Pins)  36.5 (1.44) 36.5 (1.44)	A1190 Dual Single 2.5 × 9.5 Pitch (0.09 × 0.37)  φ2.5 (I.D.) (0.09)
A1191 SIP 26L (0.98)  26 (1.02) 0.8 (0.03)	A1192 SIP 50L (1.97)  52 (2.05) 0.8 (0.03)	A1203 QFP 35 × 35 (1.36 × 1.36)  35.2 (1.39) 35.2 (1.39)	A1214 SOJ 10 × 26 (0.39 × 1.02)  12 (0.47) 25.9 (1.02)	A1215 QFP 42.5 × 42.5 (1.67 × 1.67)  42.5 (1.67) 42.5 (1.67)	A1258 SOP 7.6 × 12.7 (0.3 × 0.5)  8.2 (0.32) 11.7 (0.46)

Parts List (Station)

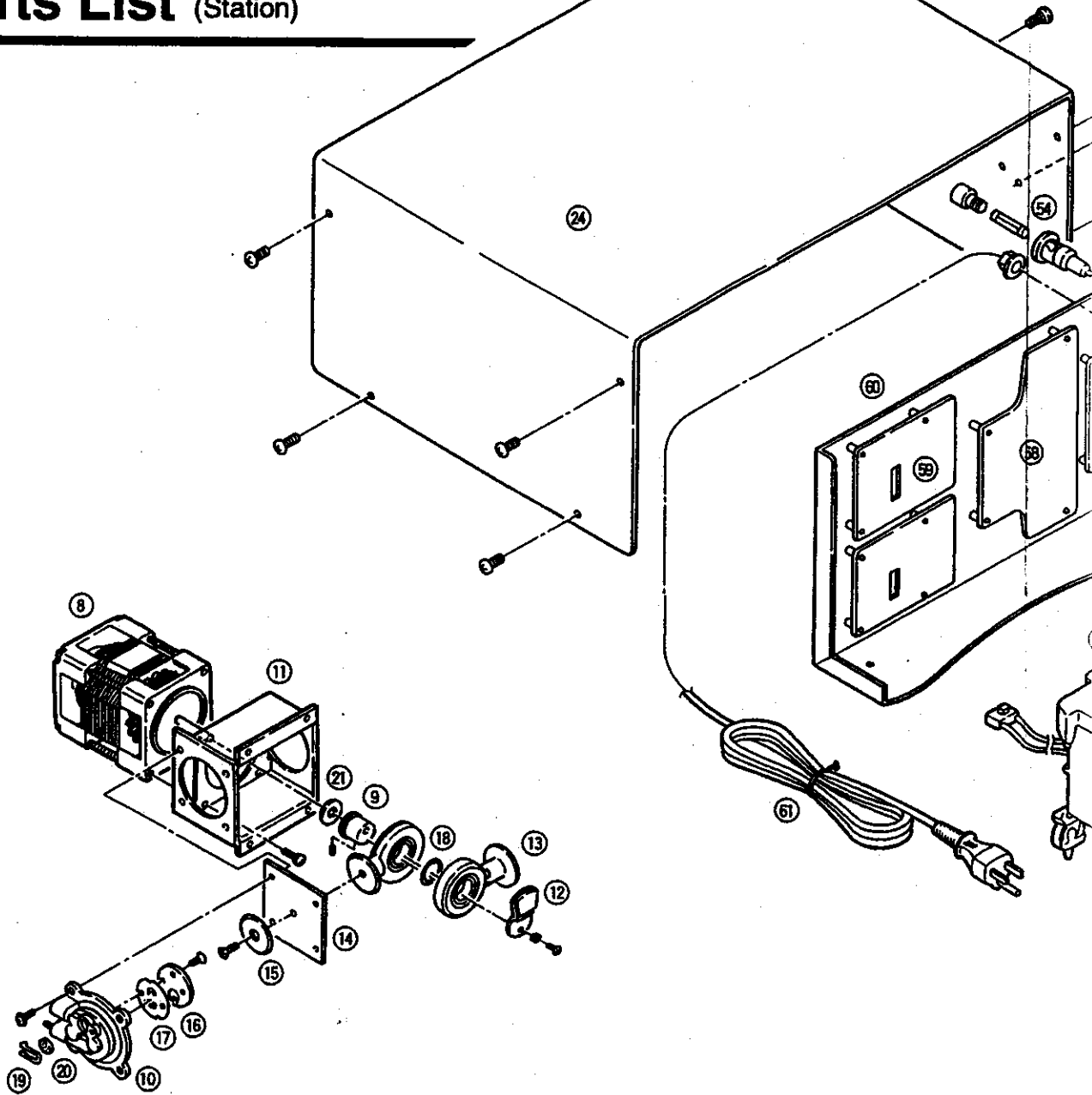

Item No.	Part No.	Part Name	Description
1	B1924	Transformer	120V-24V
2	B1370	Cement Resistor	2K Ω 30W
3	B1366	Sound-proof Tank Support	
4	B1368	Sound-proof Tank	
5	B1374	Silicone Tube	
6	B1451	Pump	120V
7	B1925	PVT Tube	ø4Xø6X270(ø) ø0.16Xø0.24X16.8(ø)
8	B1866	Motor	
9	B1049	Crank Shaft	
10	B1050	Pump Head	
11	B1052	Pump Frame	
12	B1053	Balance Weight	
13	B1312	Crank	
14	A1013	Diaphragm	Set of 2
15	B1055	Diaphragm Setting Plate	
16	B1056	Fixing Plate	

Item No.	Part No.	Part Name	Description
17	A1014	Valve Plate	Set of 2
18	B1057	Ring for Bearing	
19	B1313	Filter Retaining Pin	
20	B1059	Exhaust Filter	Set of 2
21	B1300	Plain Washer	ø6.5Xø15X(ø) ø0.26Xø0.4X(ø)ø(ø)
22	B1926	PVT Tube	ø4Xø6X130(ø) ø0.16Xø0.24X16.8(ø)
23	B1927	Relay	
24	B1928	Cover	
25	B1929	Chassis	
26	B1930	LED Lamp / Solder Side	
27	B1084	Switch	
28	B1028	Knob	
29	926-429	Potentiometer	
30	B1931	LED Lamp / Desolder Side	
31	B1084	Switch	
32	B1028	Knob	

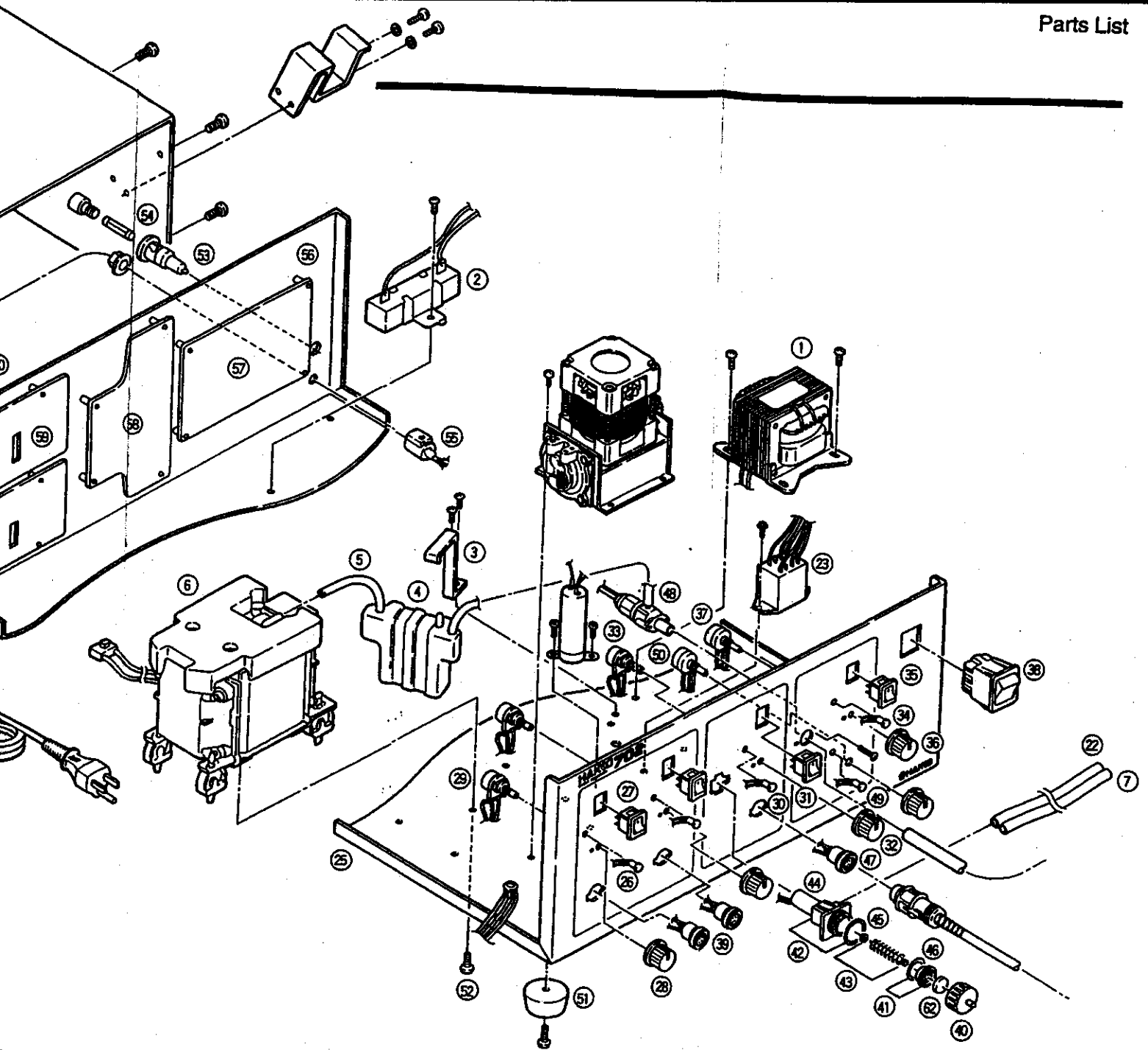

Item No.	Part No.	Part Name	Description
33	B1932	Potentiometer / 1K Ω	
34	B1933	LED Lamp / SMD Rework Air	Side
35	B1094	Switch	
36	B1028	Knob	
37	B1940	Potentiometer / SMD Air Flow 200K Ω	
38	B1443	Power Switch	
39	826-209	Receptacle	
40	B1029	Vacuum Outlet Cap	
41	B1030	Filter Retainer	
42	B1274	Vacuum Outlet Retainer	
43	B1032	Valve	
44	B1033	Solenoid w / Valve	
45	B1034	O-Ring S-20	
46	B1035	Packing	
47	B1662	Receptacle	
48	B1856	Air Nozzle	

Item No.	Part No.	Part Name	Description
49	B1934	LED Lamp / SMD Rework Heater	Side
50	B1941	Volume / SMD Heater Side	100K Ω
51	B1240	Rubber Foot	Set of 4
52	B1371	Pump Securing Screw	
53	B1041	Fuse Holder	
54	B1935	Fuse	8A
55	B1208	Cord Stopper	
56	B1114	Locking Spacer	Set of 4
57	B1448	P.W.B. / SMD Rework Side	120V
58	B1936	P.W.B. / Desolder Side	
59	B1937	P.W.B. / Solder Side	
60	B1205	Fastener	
61	B1938	Power Cord / 3 Core & American Plug	
62	A1009	Ceramic Paper Filter (S)	

Parts List (SMD Rework Iron)

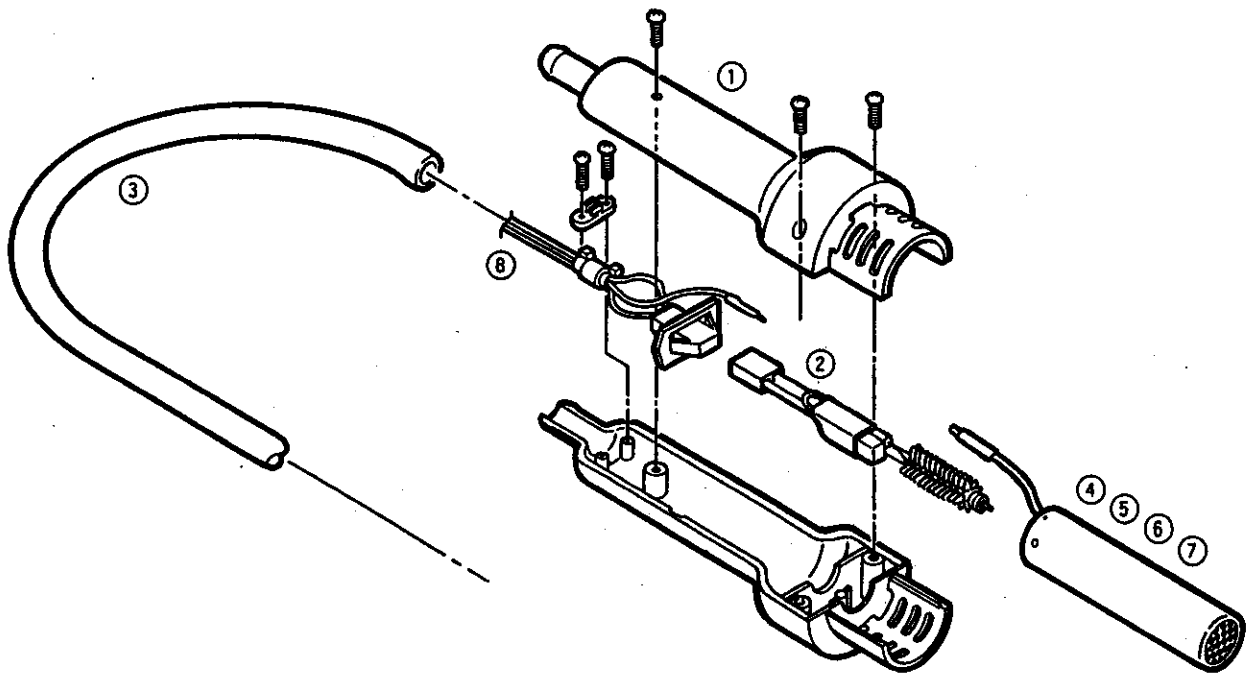

Item No.	Part No.	Part Name	Description
1	B1923	Handle	
2	A1145	Heating Element	120V/250W
3	B1188	Silicone Hose	
4	B1441	Pipe Assy	
5	B1842	Heater Protection Pipe	
6	B1843	Mica Pipe A	ø20.5(OD)X54(L) ø0.8X2.1(I)in.
7	B1844	Mica Pipe B	ø20.5(OD)X8(L) ø0.8X0.3(I)in.
8	B1360	Cord Assy	

Parts List (HAKKO 807)

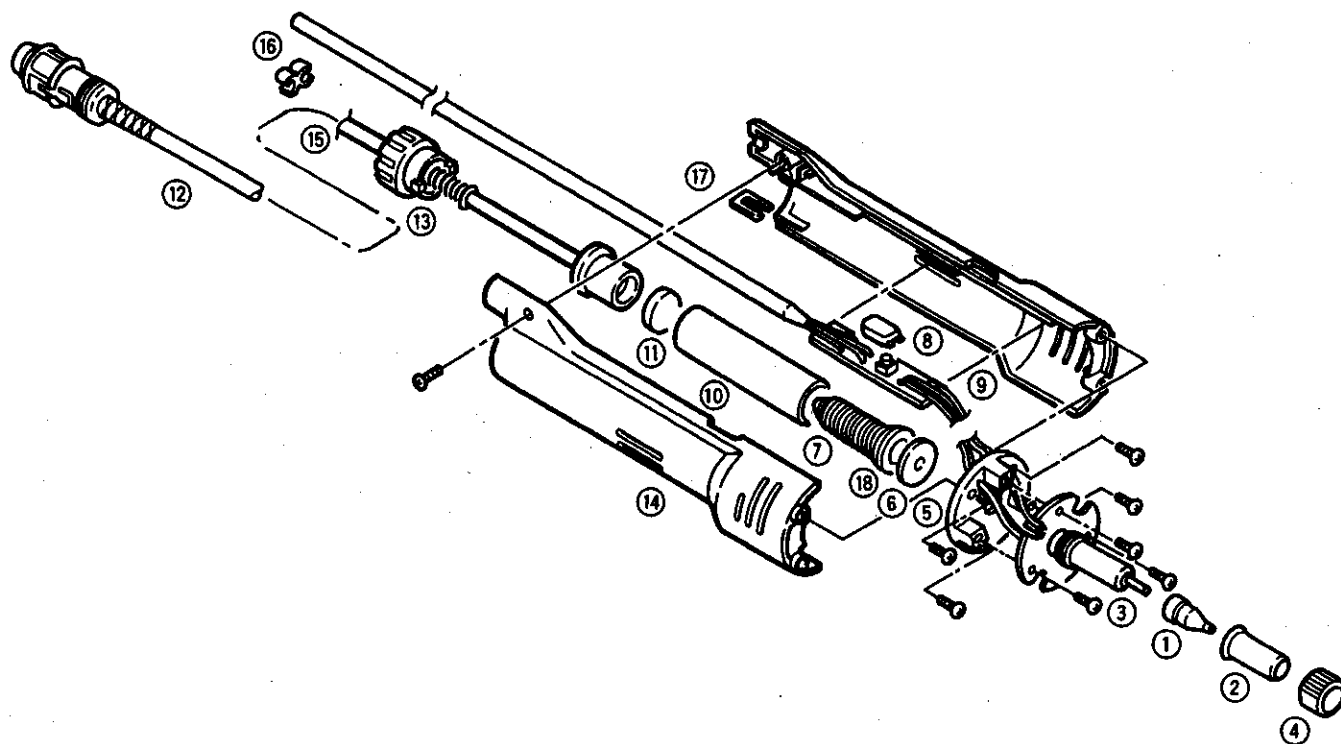

Item No.	Part No.	Part Name	Description
1		Nozzle/See Replacement Parts	
2	B1653	Element Cover	
3	A1174	Heating Element	24V-60W
4	B1015	Nut	
5	B1654	Flange	
6	A1304	Front Holder	
7	A1030	Spring Filter	Set of 10
8	B1655	Button	
9	B1656	Board w / Switch	
10	B1916	Filter Pipe	
11	A1033	Ceramic Paper Filter-L	Set of 10
12	B1657	Cord Asse'y	
13	B1917	Back Holder Asse'y	
14	B1659	Housing	
15	B1023	Hose / E.S.D.	
16	B1024	Cord Holder	Set of 4
17	B1660	Housing Fastener	
18	B1915	Filter Holder	

Parts List (Iron)

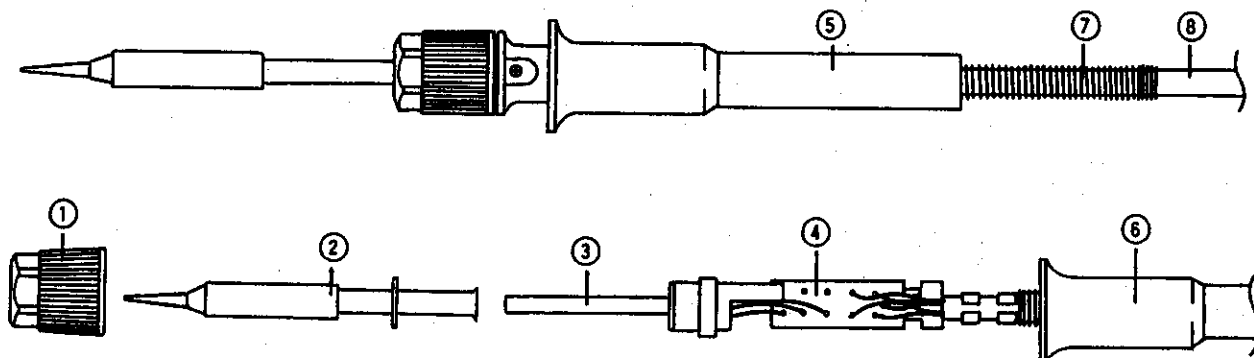

Item No.	Part No.	Part Name	Description
1	900S-006S	Nut	
2	TIP/See Replacement Parts		
3	900S-H	Heating Element	Ceramic, 24V-50W
4	900S-101	Terminal Board	w / Cord Stopper
5	900S-001S	Handle	w / Handle Cover, E.S.D.
6	900S-034S	Handle Cover	
7	900S-010	Cord Bushing	
8	900S-039S	Cord Assy	E.S.D.

Parts List (Iron)

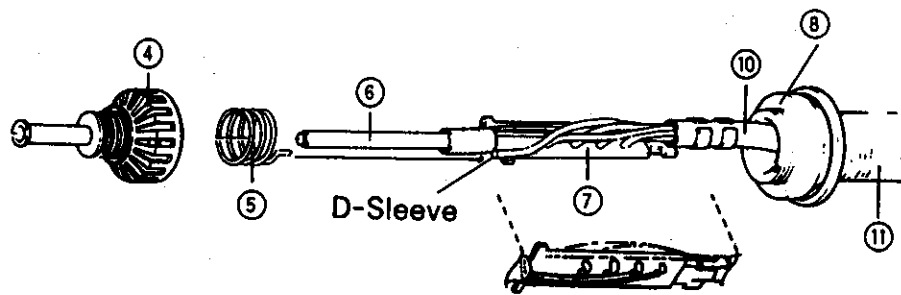
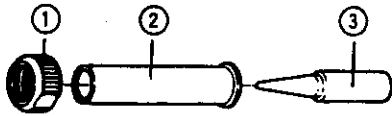

Item No.	Part No.	Part Name	Description
1	B1784	Nut	*Old Part No. 900M-008
2	B1786	Tip Enclosure	*Old Part No. 900M-002
3	Tip/See Replacement Parts		
4	B1921	Nipple	E.S.D.*Old Part No. 900M-044S
5	900M-036	Grounding Spring	
6	900M-H	Heating Element	Ceramic, 24V-50W
7	900M-101	Terminal Board	w / Cord Stopper
8	900M-001S	Handle	w / Handle Cover, E.S.D.
9	900M-010S	Cord Bushing	E.S.D.(Not Shown)
10	900-039S	Cord Ass'y	E.S.D.
11	B1186	Handle Cover	E.S.D.*Old Part No. 900-034S

Wiring

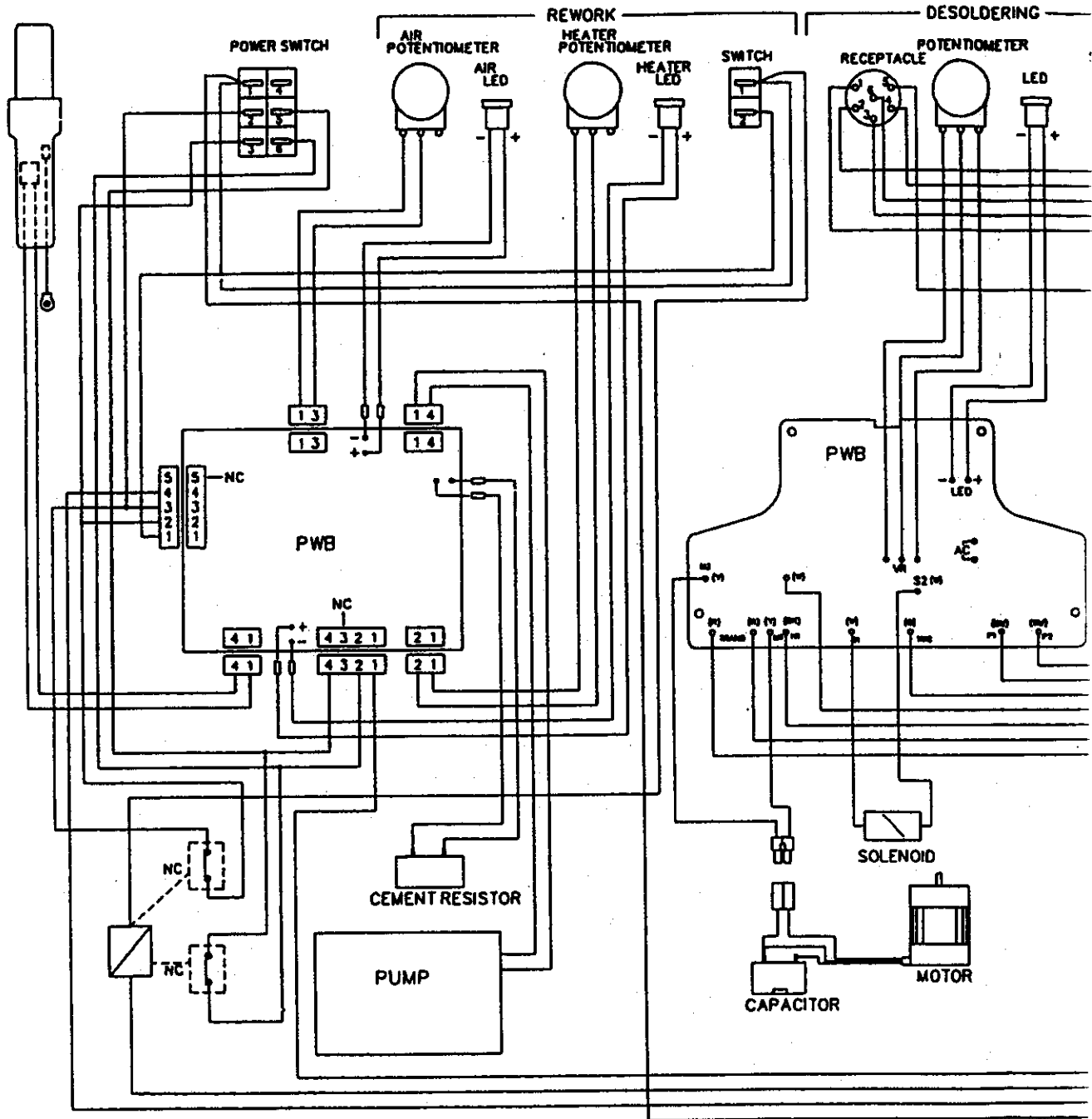

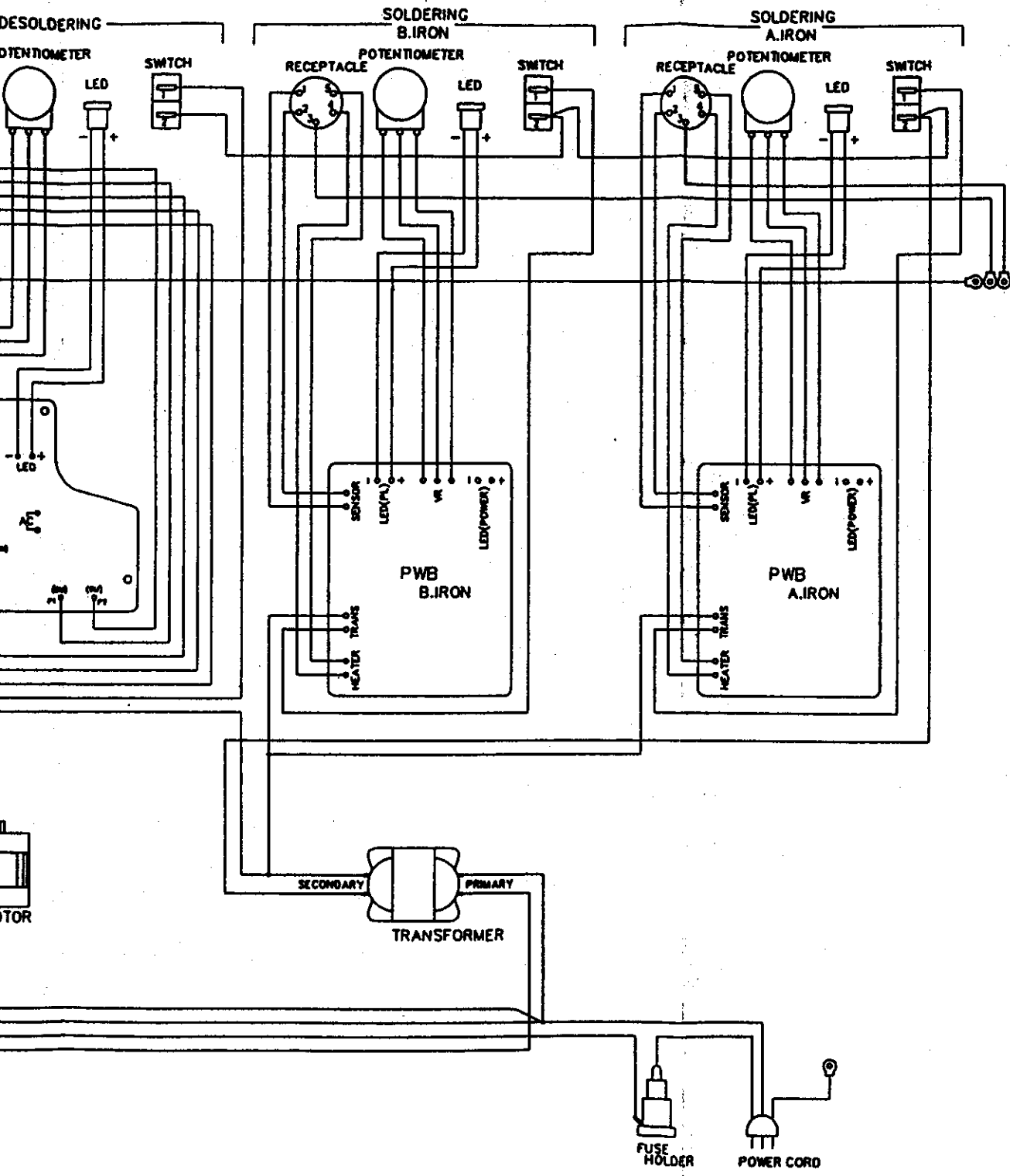

 **HAKKO**
HAKKO CORPORATION

HEAD OFFICE

4-5, SHIOKUSA 2-CHOME, NANIWA-KU, OSAKA, 556-0024 JAPAN
TEL: (06) 561-3225 FAX: (06) 561-8466
TLX: HAKKOOSA J65274

OVERSEAS AFFILIATES

U.S.A.: AMERICAN HAKKO PRODUCTS, INC.
25072 ANZA DR. SANTA CLARITA, CA 91355, U.S.A.
TEL: (805) 294-0090 FAX: (805) 294-0096
Toll Free (800)88-HAKKO
4 2 5 5 6

S'PORE: HAKKO PRODUCTS PTE., LTD.
1, GENTING LINK #02-04, PERFECT INDUSTRIAL
BUILDING, SINGAPORE 349518
TEL: 7482277 FAX: 7440033

HONG KONG: HAKKO DEVELOPMENT CO., LTD.
ROOM 804 EASTERN HARBOUR CENTRE,
28 HOI CHAK STREET, QUARRY BAY, HONG KONG.
TEL: 2811-5588 FAX: 2590-0217

PHILIPPINES: HAKKO PHILS TRADING CO., INC.
NO. 415 WINDSOR TOWER CONDOMINIUM,
163 LEGASPI ST., LEGASPI VILLAGE MAKATI,
METRO MANILA, PHILIPPINES
TEL: 2-817-07-12 FAX: 2-810-76-49

MALAYSIA: HAKKO PRODUCTS SDN BHD
MALAYSIA HEAD OFFICE: PETALING JAYA
LOT 35/1 THE HIGHWAY CENTRE JALAN 51/205 46050
PETALING JAYA WEST MALAYSIA
TEL: 03-7941333 FAX: 03-7911232

PENANG BRANCH: TEL: 04-644 6669 FAX: 04-644 8628
JOHORE BAHRU BRANCH: TEL: 07-236 7766 FAX: 07-237 4655