

TAS

100 Series

OPERATIONS MANUAL

**100 Series
Telephone Network Emulator
Operations Manual**

Telecom Analysis Systems, Inc.
34 Industrial Way East
Eatontown, NJ 07724

Phone: (908) 544-8700

FAX: (908) 544-8347

This manual applies to the TAS 100 Series
using software version 4.30 or higher.

Page Part Number: 2700-3015, Version 2.20

Copyright © 1996, Telecom Analysis Systems, Inc.

Printed in the USA 3/96

Information furnished by Telecom Analysis Systems, Inc. is believed to be accurate and reliable. However, no responsibility is assumed by Telecom Analysis Systems, Inc. for its use. Specifications are subject to change without notice.

ABOUT THIS MANUAL

The TAS 100 Series, Telephone Network Emulator Operations Manual contains the information necessary to effectively operate the TAS 100 Series. We recommend that you become familiar with the manual before attempting to use the unit. Some users may want to explore the full capabilities of the TAS 100 Series, while others may want to utilize only the feature needed for their current applications. In any case, this manual contains the information you need. The manual is presented as follows:

Introduction provides a generalized view of all the members of the TAS 100 family and summarizes the differences between the various models. This section also provides some general applications examples and the information necessary to install the TAS 100 Series. A description of the front and rear panel is also provided.

Local Operation provides the information necessary to operate the TAS 100 Series manually from the front panel. A complete discussion of the menu structure is included in this section. The graphic menu trees provide an efficient way to view and find the menu of interest.

Reference provides a comprehensive description of the features and functions of the TAS 100 Series.

Remote Operation provides the information needed to control the TAS 100 Series remotely via the RS-232C or GPIB (IEEE-488) interfaces. This section is essential reading for those who will be integrating the TAS 100 Series into automatic test equipment (ATE) systems.

Command Reference provides a description of the commands used for remote control operation.

Error Codes provides the descriptions of the TAS 100 Series error codes which might be encountered during power-up or operation.

Technical Specifications contains the detailed system specifications, connector pinouts, and frequency response plots.

Appendixes provide helpful supplemental information including a feature release history for the 100 Series, a detailed list of the contents of the recallable ROM files, in addition to a performance verification procedure for the 100 Series.

This page intentionally left blank.

TABLE OF CONTENTS

1.0. Introduction.....	1-1
1.1. Overview	1-1
1.2. TAS 100 Series Applications.....	1-2
1.2.1. Modem Evaluation.....	1-2
1.2.2. Modem Manufacturing Test.....	1-3
1.2.3. PC Bus Modem Test	1-4
1.2.4. FAX Testing.....	1-5
1.2.5. Communications Software Evaluation	1-5
1.3. TAS 100 Series Product Highlights.....	1-6
1.4. Guided Tour	1-9
1.4.1. Front Panel Description	1-9
1.4.2. Rear Panel Description.....	1-13
1.5. Quick Start Procedure.....	1-16
1.6. Installation	1-17
1.6.1. Standalone TAS 100 Series Test Setup	1-18
1.6.2. TAS 100 Series Setup with Loop Emulation	1-20
2.0. Local Operation	2-1
2.1. Overview	2-1
2.2. Getting Started.....	2-2
2.2.1. Recalling Predefined Test Configurations.....	2-2
2.2.2. Defining and Saving Custom Test Configurations.....	2-4
2.3. Menu Overview	2-7
2.3.1. Menu Summary.....	2-7
2.3.2. Control Key Summary	2-12
2.4. Setting I/O Levels and I/O Configuration Parameters	2-14
2.4.1. Combined vs. Independent Control of I/O Levels	2-14
2.4.2. Setting Nominal Input Level.....	2-15
2.4.3. Executing an Input AGC	2-15
2.4.4. Setting the Output Level	2-16
2.4.5. Executing an Output AGC	2-16
2.4.6. Controlling Channel Bypass	2-16
2.5. Setting Channel Impairments.....	2-17

2.5.1. Combined vs. Independent Control of Channel Impairments.....	2-17
2.5.2. Setting Simulation Direction.....	2-18
2.5.3. Setting Gain/Delay Distortion Parameters	2-19
2.5.4. Setting White Noise Parameters.....	2-20
2.5.5. Setting Intermodulation Distortion Parameters	2-21
2.5.6. Setting Frequency Shift Parameters.....	2-23
2.5.7. Setting Amplitude Jitter Parameters	2-24
2.5.8. Setting Phase Jitter Parameters.....	2-25
2.5.9. Setting Gain Hits Parameters	2-26
2.5.10. Setting Phase Hits Parameters.....	2-27
2.5.11. Setting Impulse Noise Parameters	2-28
2.5.12. Setting PCM Simulation Parameters [151, 152, 181].....	2-29
2.5.13. Setting PCM Simulation Parameters [182]	2-30
2.5.14. Setting Single Frequency Interference Parameters	2-31
2.6. Setting Echo/Satellite Delay Parameters	2-32
2.6.1. Setting Near Talker Echo Parameters	2-32
2.6.2. Setting Far Talker Echo/Satellite Delay Parameters	2-33
2.7. Controlling Central Office Emulation	2-34
2.7.1. Selecting an Exchange Configuration.....	2-35
2.7.2. Entering Telephone Numbers.....	2-36
2.7.3. Entering Loop Current Generator Parameters.....	2-37
2.7.4. Entering Ringing and Ringback Parameters.....	2-38
2.7.5. Entering Dial Tone Parameters	2-40
2.7.7. Controlling Reverse Battery Polarity Signalling.....	2-42
2.7.8. Selecting the Hybrid Balance Network.....	2-43
2.7.9. Controlling External Access to the 4-Wire Path	2-43
2.7.10. Controlling the Program Resistor.....	2-44
2.7.11. Controlling the 4-Wire Configuration Loopback Modem Indicator	2-44
2.7.12. Entering Network Switching Delay and On Hook Delay Parameters.....	2-45
2.7.13. Entering Disconnect Signal Parameters	2-46
2.8. Monitoring Signal Level.....	2-47
2.8.1. Measuring Signal Level	2-47
2.8.2. Controlling Audio Volume	2-48
2.9. Performing Dialing Analysis	2-49

2.9.1. Entering Dial Pulse Make/Break Detection Intervals.....	2-49
2.9.2. Performing Readback of Dialed Telephone Numbers.....	2-50
3.0. Reference.....	3-1
3.1. Overview.....	3-1
3.2. Interfaces and Status Indicators.....	3-2
3.2.1. Front Panel LEDs and Interfaces.....	3-2
3.2.2. Rear Panel Terminal Strips, Jacks and Ports.....	3-3
3.3. Transmission Channel Simulation.....	3-7
3.3.1. Overview.....	3-7
3.3.2. Channel Configuration.....	3-8
3.3.3. Input Level Control.....	3-10
3.3.4. Output Level Control.....	3-11
3.3.5. Analog Impairments Generators.....	3-13
3.3.6. Digital Impairments.....	3-23
3.3.7. Echo/Satellite Delay.....	3-25
3.4. Measurement/Monitoring.....	3-36
3.4.1. Level Measurement Module.....	3-36
3.4.2. Monitoring.....	3-39
3.5. Central Office Emulation.....	3-40
3.5.1. Exchange Configuration Features.....	3-41
3.5.2. 4-Wire Configuration Features.....	3-45
3.5.3. 2-Wire Configuration Features.....	3-45
3.5.4. Loop Current Generator.....	3-51
3.5.5. Ringing Generator.....	3-52
3.5.6. Call Progress Tones and Switching Features.....	3-53
3.5.7. Forced Signalling.....	3-58
3.5.8. Dialing Analysis Features.....	3-58
4.0. Remote Operation.....	4-1
4.1. Overview.....	4-1
4.2. Remote Control Features.....	4-3
4.3. Configuring the TAS 100 Series for Remote Control.....	4-4
4.3.1. IEEE-488 Configuration.....	4-4
4.3.2. RS-232C CR/LF Configuration.....	4-5

4.3.3. RS-232C ACK/NAK Configuration	4-6
4.4. TAS 100 Series Command Protocol	4-7
4.4.1. Command Types	4-7
4.4.2. Command Message Format	4-8
4.4.3. Response Formats	4-9
4.4.4. Special Commands	4-10
4.5. Transmission Layer Protocols	4-12
4.5.1. RS-232C CR/LF Protocol	4-12
4.5.2. TAS 100 Series ACK/NAK Protocol	4-13
4.5.3. TAS 100 Series GPIB Protocol	4-15
4.6. Programming Sequence	4-20
4.6.1. Transmission Channel Impairment Parameters	4-20
4.6.2. Central Office Parameters	4-20
5.0. Command Reference	5-1
5.1. Overview	5-1
5.2. TAS 100 Series Network Emulator Commands for Version 4.20	5-2
5.2.1. Convention to Specify Commands	5-2
5.2.2. Command Summary	5-3
5.3. Command Descriptions	5-8
5.3.1. Systems Administration (AD)	5-9
5.3.2. Amplitude Jitter (AJ)	5-16
5.3.3. Echo Control (EC)	5-18
5.3.4. Frequency Shift (FS)	5-20
5.3.5. Gain/Delay (GD)	5-22
5.3.6. Gain Hits (GH)	5-27
5.3.7. Impulse Noise (IM)	5-30
5.3.8. Impairments Generator I/O (IO)	5-32
5.3.9. Line Control (LC)	5-35
5.3.10. Signal Measurement (MM)	5-39
5.3.11. Nonlinear Distortion (NL)	5-40
5.3.12. Pulse-Code Modulation (PC)	5-42
5.3.13. Phase Hits (PH)	5-45
5.3.14. Phase Jitter (PJ)	5-48

5.3.15. Random Noise (RN)	5-50
5.3.16. Satellite Delay (SD)	5-52
5.3.17. Single Frequency Interference (SF)	5-54
5.3.18. Network Signalling (SG)	5-56
5.3.19. Switching (SW)	5-66
6.0. Error Codes.....	6-1
7.0. Technical Specifications.....	7-1
7.1. General	7-1
7.2. Signal Measurement	7-2
7.3. Impairments Generator I/O	7-2
7.4. Residual Characteristics	7-3
7.5. Transmission Impairments	7-4
7.6. Central Office Emulation	7-11
7.7. Interfaces	7-16
7.8. Gain and Delay Distortion Characteristics.....	7-19
Appendix 1: Feature Release History	A1-1
A1.1. Version 4.30	A1-1
A1.2. Version 4.20	A1-1
A1.3. Version 4.10	A1-1
A1.4. Version 4.00	A1-2
A1.5. Version 3.11	A1-3
A1.6. Version 3.10	A1-3
A1.7. Version 3.01	A1-4
A1.8. Version 3.00	A1-4
A1.9. Version 2.30	A1-5
A1.10. Version 2.20	A1-5
A1.11. Version 2.10	A1-5
A1.12. Version 2.00	A1-6
Appendix 2: ROM File Contents for Recallable Files	A2-1
A2.1. Central Office Parameters	A2-3
A2.1.1. Central Office Parameters for Belgium.....	A2-3
A2.1.2. Central Office Parameters for Canada	A2-4
A2.1.3. Central Office Parameters for EIA496A_L1 thru EIA496A_L6.....	A2-4

A2.1.4. Central Office Parameters for Factory Default	A2-4
A2.1.5. Central Office Parameters for France	A2-5
A2.1.6. Central Office Parameters for Germany	A2-6
A2.1.7. Central Office Parameters for Great Britain.....	A2-7
A2.1.8. Central Office Parameters for Italy	A2-8
A2.1.9. Central Office Parameters for Japan.....	A2-9
A2.1.10. Central Office Parameters for Korea	A2-10
A2.1.11. Central Office Parameters for Netherlands	A2-11
A2.1.12. Central Office Parameters for Norway.....	A2-12
A2.1.13. Central Office Parameters for RITT1.....	A2-13
A2.1.14. Central Office Parameters for RITT2.....	A2-14
A2.1.15. Central Office Parameters for Singapore	A2-14
A2.1.16. Central Office Parameters for Sweden.....	A2-15
A2.1.17. Central Office Parameters for Switzerland	A2-16
A2.1.18. Central Office Parameters for Taiwan	A2-17
A2.1.19. Central Office Parameters for TSB37_L7 thru TSB37_L16	A2-18
A2.1.20. Central Office Parameters for EIA_L17a thru EIA_L24a	A2-18
A2.1.21. Central Office Parameters for USA Average	A2-18
A2.1.22. Central Office Parameters for USA Worst Case.....	A2-19
A2.2. Impairment Parameters	A2-20
A2.2.1. Impairment Parameters for Belgium.....	A2-20
A2.2.2. Impairment Parameters for Canada	A2-21
A2.2.3. Impairment Parameters for EIA496A_L1.....	A2-21
A2.2.4. Impairment Parameters for EIA496A_L2.....	A2-22
A2.2.5. Impairment Parameters for EIA496A_L3.....	A2-23
A2.2.6. Impairment Parameters for EIA496A_L4.....	A2-24
A2.2.7. Impairment Parameters for EIA496A_L5.....	A2-25
A2.2.8. Impairment Parameters for EIA396A_L6.....	A2-26
A2.2.9. Impairment Parameters for Factory Default	A2-27
A2.2.10. Impairment Parameters for Various Countries	A2-27
A2.2.11. Impairment Parameters for RITT1.....	A2-28
A2.2.12. Impairment Parameters for RITT2.....	A2-29
A2.2.13. Impairment Parameters for TSB37_L7.....	A2-31
A2.2.14. Impairment Parameters for TSB37_L8.....	A2-32

A2.2.15. Impairment Parameters for TSB37_L9.....	A2-34
A2.2.16. Impairment Parameters for TSB37_L10.....	A2-35
A2.2.17. Impairment Parameters for TSB37_L11.....	A2-37
A2.2.18. Impairment Parameters for TSB37_L12.....	A2-38
A2.2.19. Impairment Parameters for TSB37_L13.....	A2-40
A2.2.20. Impairment Parameters for TSB37_L14.....	A2-41
A2.2.21. Impairment Parameters for TSB37_L15.....	A2-43
A2.2.22. Impairment Parameters for TSB37_L16.....	A2-44
A2.2.23. Impairment Parameters for EIA_L17a.....	A2-46
A2.2.24. Impairment Parameters for EIA_L17b.....	A2-47
A2.2.25. Impairment Parameters for EIA_L17c.....	A2-49
A2.2.26. Impairment Parameters for EIA_L18a.....	A2-50
A2.2.27. Impairment Parameters for EIA_L18b.....	A2-52
A2.2.28. Impairment Parameters for EIA_L18c.....	A2-53
A2.2.29. Impairment Parameters for EIA_L19a.....	A2-55
A2.2.30. Impairment Parameters for EIA_L20a.....	A2-56
A2.2.31. Impairment Parameters for EIA_L21a.....	A2-58
A2.2.32. Impairment Parameters for EIA_L22a.....	A2-59
A2.2.33. Impairment Parameters for EIA_L23a.....	A2-61
A2.2.34. Impairment Parameters for EIA_L24a.....	A2-62
A2.2.35. Impairment Parameters for USA Average.....	A2-64
A2.2.36. Impairment Parameters for USA Worst Case.....	A2-65
Appendix 3: Performance Verification Procedure.....	A3-1
A3.1. Required Verification Equipment.....	A3-1
A3.2. Pre-Verification Operations TAS 100 Unit.....	A3-2
A3.3. Output Signal Verification and Signal Level Measurements.....	A3-2
A3.3.1. 4-Wire Mode.....	A3-2
A3.3.2. 2-Wire Mode.....	A3-3
A3.4. White Noise Level Setting Verification.....	A3-4
A3.5. Central Office Functions and Signalling Verifications.....	A3-5

This page intentionally left blank.

1.0. INTRODUCTION

1.1. Overview

The TAS 150, 151, 152, 181, and 182 are the latest generation of models in the 100 Series of Telephone Network Emulators from Telecom Analysis Systems (TAS). The Model 150, 151, 152, 181, and 182 are enhanced compatible replacements for the TAS 100, 101, 102, 121, and 122 respectively.

The TAS 100 Series provides a convenient solution for development, testing, and evaluation of high speed modems, fax machines, voice/data terminals, transmission test sets, and other voice bandwidth data communications devices. The 100 Series offers either unidirectional or bidirectional impairment simulation including PCM (Figure 1-1) as well as echo simulation capabilities and the ability to emulate virtually all worldwide central office signaling formats.

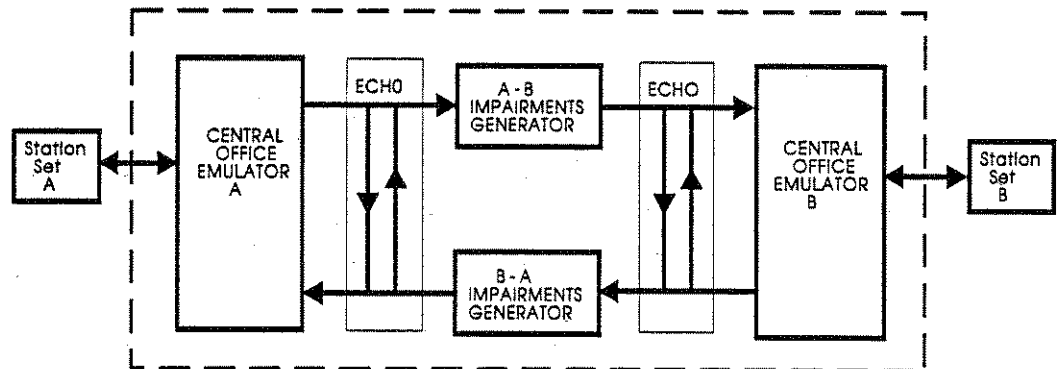

Figure 1-1. TAS 100 Series Block Diagram

Because the 100 Series is compatible with testing standards from EIA, CCITT, RITT, ETSI, Bell Operating Companies, AT&T, Nippon Telephone and Telegraph, and many other companies and industry organizations, test results have immediate credibility. In addition, the TAS 150, 151, 152, 181, and 182 are software-compatible with the industry standard TAS 100, 101, 102, 121, and 122, thereby protecting your prior investment in test procedures and software.

The 100 Series works with the TAS Gemini Dual Terminal Emulator and TASKIT software to provide completely automatic modem testing. The 100 Series test results track with those obtained on the popular TAS 1010 and TAS Series II simulators, so the test results agree with the largest installed base of Telephone Network Simulators in the world.

1.2. TAS 100 Series Applications

The 100 Series can be applied as a standalone telephone network emulator, or as part of an automatic test system. It can be used to test any product that communicates over the public switched telephone network (PSTN).

1.2.1. Modem Evaluation

The 100 Series is the heart of a powerful, advanced, automatic modem test system. Modems can easily be tested to the latest industry standards. Figure 1-2. below shows a modem evaluation setup using the 100 Series Telephone Network Emulator.

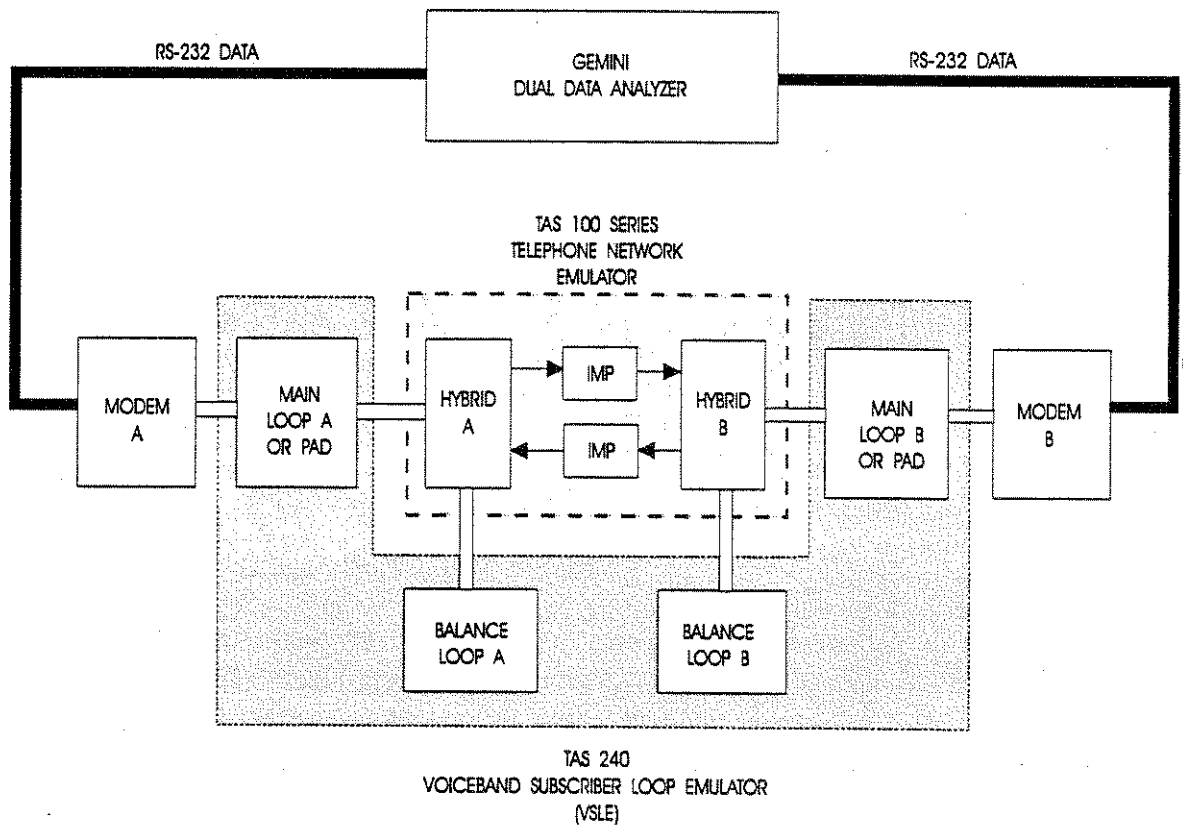

Figure 1-2. Automatic Modem Testing System

1.2.2. Modem Manufacturing Test

The TAS 100 Series together with the TAS Gemini Dual Terminal Emulator provides a cost-effective, complete solution for manufacturing test of modems and FAX devices. A modem manufacturing test setup using the 100 Series and the Gemini Dual Terminal Emulator is shown in Figure 1-3.

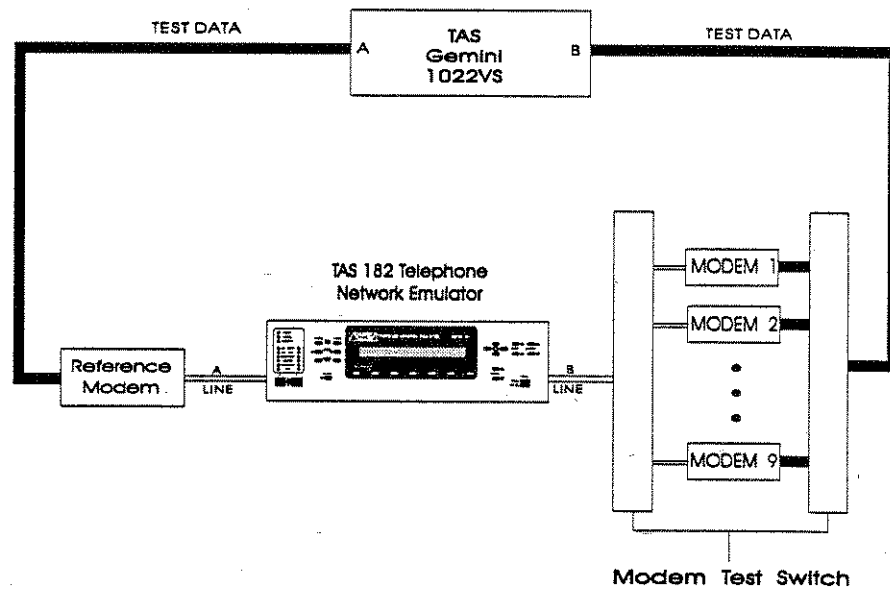

Figure 1-3. Modem Manufacturing Test Setup

1.2.3. PC Bus Modem Test

TAS PC-Pod™ software accessory makes testing PC internal modems a snap. PC-Pod™ shuttles data between modem ports and serial ports, so that bus modems can be tested by standard data analyzers such as TAS Gemini. A block diagram of this PC bus modem test is shown in Figure 1-4.

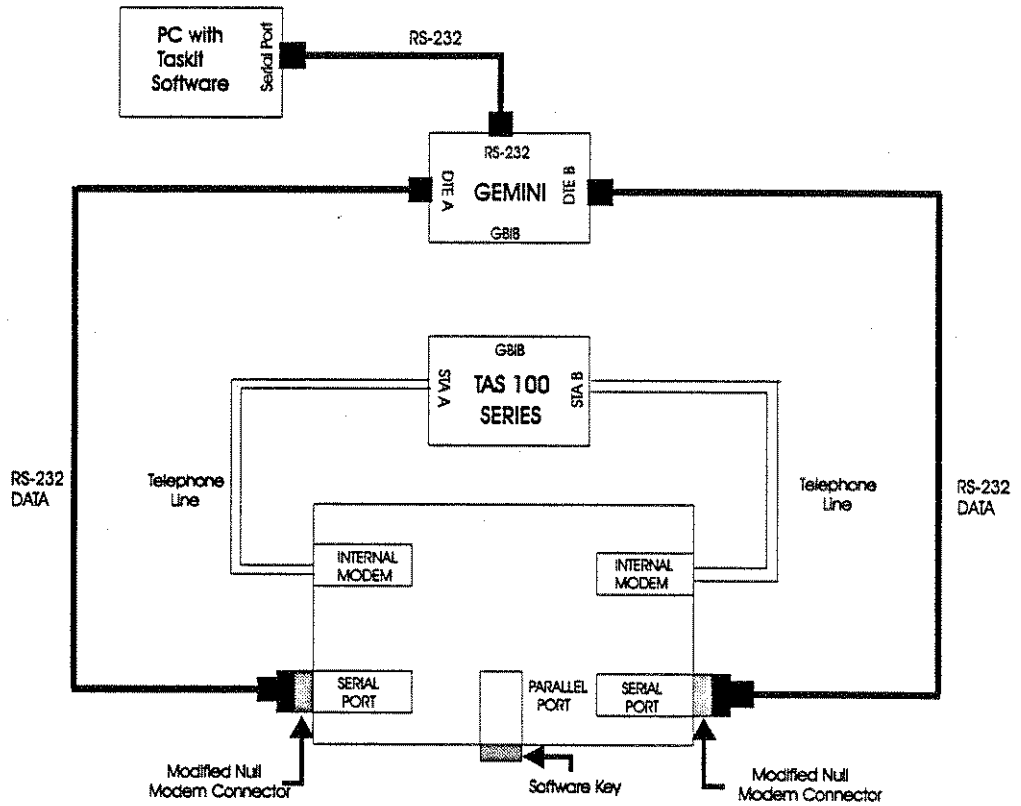

Figure 1-4. PC Bus Modem Test Using PC-Pod.

1.2.4. FAX Testing

The TAS 100 Series is the choice of FAX manufacturers worldwide. The 100 Series accurately simulates network conditions to allow thorough evaluation of FAX image quality and call setup performances. A FAX testing setup using the 100 Series is shown in Figure 1-5.

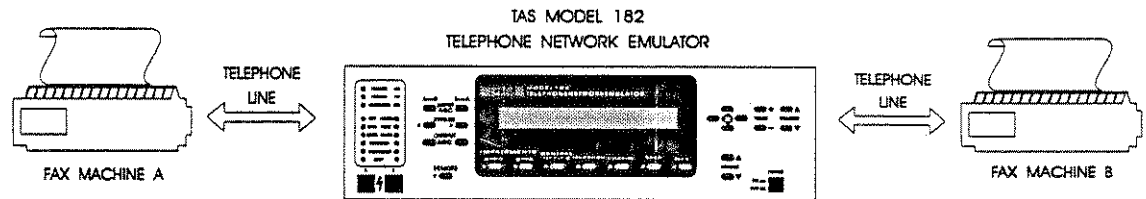

Figure 1-5. Fax Testing Setup Using the TAS 100 Series

1.2.5. Communication Software Evaluation

The TAS 100 Series lets you evaluate real-world performance of communication software. Facilitates thorough evaluation of protocol error recovery, throughput, and data compression performance. A communication software evaluation setup using the 100 Series is shown in Figure 1-6.

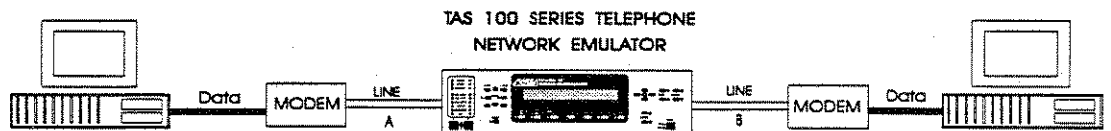

Figure 1-6. Evaluation of Communication Software with the TAS 100 Series

1.3. TAS 100 Series Product Highlights

Table 1-1 shown below, along with the information that follows it, provides a high level summary of the features available in the TAS 100 Series.

FEATURES	150	151	152	181	182
Local Front Panel Operation	X	X	X	X	X
Remote Control Operation					
(IEEE-488 and RS-232C)	X	X	X	X	X
Central Office Emulation	X	X	X	X	X
Network Status Monitor	X	X	X	X	X
Impairment Generator Features					
Channel Attenuation	X	X	X	X	X
Automatic Gain Control (AGC)	X	X	X	X	X
Echo	X	X	X	X	X
White Noise	-	UNI	BI	UNI	BI
Gain Distortion	-	UNI	BI	UNI	BI
Delay Distortion	-	UNI	BI	UNI	BI
Satellite Delay	-	UNI	BI	UNI	BI
PCM Coding Distortion	-	UNI	BI	UNI	BI
PCM Robbed Bit Signaling Dist.	-	UNI	BI	UNI	BI
# of PCM Links	0	1	1	1	3
Intermodulation Distortion	-	-	-	UNI	BI
Frequency Shift	-	-	-	UNI	BI
Phase Jitter	-	-	-	UNI	BI
Impulse Noise	-	-	-	UNI	BI
Gain Hits	-	-	-	UNI	BI
Phase Hits	-	-	-	UNI	BI
Amplitude Jitter	-	-	-	-	BI
Single Frequency Interference	-	-	-	-	BI
Signal Level Measurement	X	X	X	X	X
Dialed Number Display	X	X	X	X	X
Save/Recall Configuration Files	X	X	X	X	X
Dry Circuit Loop Emulator Interface (allows support of loop emulation independent of loop current and ringing levels)	X	X	X	X	X
User Selectable Disconnect Signal	X	X	X	X	X
EIA/TIA TSB-37 and TSB-37A (PN 3064)					
Recall Configuration Files	-	-	-	-	X

Table 1-1. TAS 100 Series Features Summary

X= Standard Feature UNI = unidirectional impairments BI = bidirectional impairments

- **Provides Pre-defined Network Conditions**

Pre-defined network conditions for many countries can be recalled at the touch of a button. TAS 100 Series also includes pre-defined transmission impairment conditions according to published Electronic Industries Association (EIA) specifications. Non-volatile storage is provided for user-defined test conditions.

- **Complies with U.S. and Internal Standards for Modem and Fax Testing**

The TAS 100 Series meets or exceeds impairment generation specifications put forth by EIA, CCITT, RITT, Nippon Telephone and Telegraph (NTT), AT&T, Bell System, and U.S. Department of Defense. In addition, the TAS 100 Series is compatible with the largest installed base of Telephone Network Emulators in the world the TAS 1010, and TAS Series II Telephone Network Emulators. The test results will have immediate, worldwide credibility.

- **Provides Complete Network Simulation in a Single Compact Enclosure**

The TAS 100 Series Telephone Network Emulators give complete, bidirectional impairment simulation including PCM and fully automatic, dual central office emulation, all in one compact package. Any 100 Series model can be upgraded to full impairments without adding additional boxes.

- **Easy to Set Up and Use**

All TAS 100 Series operations are accessible via easy to use front panel menus. The 100 Series also provides a straightforward, logical set of remote commands to facilitate remote control via RS-232 or GPIB.

- **Provides Unsurpassed Accuracy, Repeatability, and Reliability**

The TAS 100 Series provides precise, all-digital simulation of transmission impairments and call progress tones for precisely repeatable test results. Digital processing yields extremely low background noise, so test results are accurate even at the lowest signal levels. Digital processing also yields high reliability, because the overall component count is kept to a minimum.

All-digital impairments mean rock-solid compatibility among TAS 100 family members, and with the TAS Series II Telephone Network Emulators. TAS 100 Series impairments are compatible with IEEE 743-1984 specifications to facilitate easy verification of emulator performance using standard measuring equipment.

- **Contains Built-in Diagnostics Routines**

Built-in diagnostics check the performance of all TAS 100 Series subsystems. The TAS 100 Series executes a complete set of self-diagnostics automatically upon power-up, and upon user command.

- **Includes Advanced Measurement and Monitor Features**

The convenient Network Status Monitor shows call progress status at a glance. The TAS 100 Series also includes several measurement functions to allow complete evaluation of DCE performance. These include: True-RMS Level Meter, Dialed Digit Monitor/Display, Scope Monitor Port, and Audio Monitor.

1.4. Guided Tour

The front panel keys and display provide access to the features of the TAS 100 Series. The front panel enables the definition of transmission impairment levels, programming of central office (exchange) configurations, measurement of signal levels, set up of general system configuration parameters, saving and recalling central office and impairment configuration files.

1.4.1. Front Panel Description

Figure 1-7 shows the TAS 100 Series front panel. The following sections describe each front panel feature.

The buttons and displays on the front panel of the TAS 100 Series are partitioned into logical groups to provide a user friendly interface. This consists of menu group select keys (A->B and B->A IMPAIRMENTS, CENTRAL OFFICE, MEASURE, CONFIG, SAVE and RECALL) that are located at the center of the front panel just below the 1 row by 32 column main display. The menu navigation keys (up, down, left and right arrows), value editing and submenu select keys are located to the right of the main display. The audio volume keys are at the lower right of the panel just above the power switch. The channel I/O keys (INPUT AGC, BYPASS, and OUTPUT AGC) are grouped to the left of the display, and the line mode and switched line status are featured at the far left of the panel.

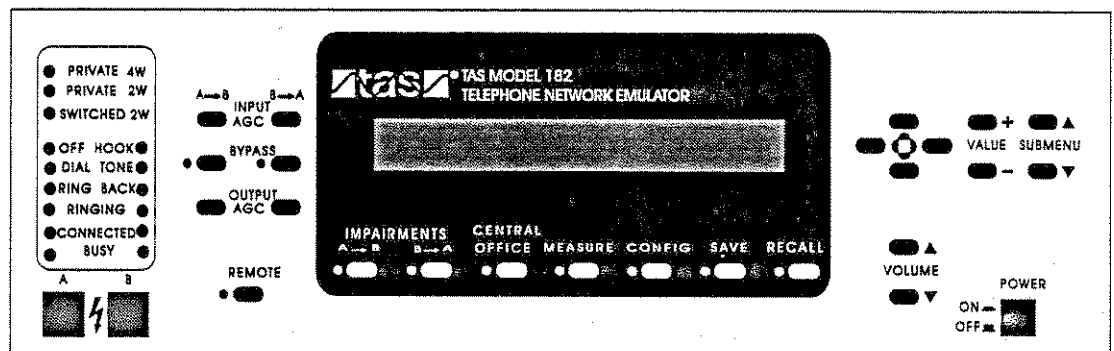

Figure 1-7. TAS 100 Series Front Panel

Front Panel Buttons

The **IMPAIRMENTS A→B** key selects the impairments menu group for the simulated channel that provides a transmission path from station A to station B. This menu group allows transmission parameters such as signal level, frequency shift, gain/delay distortion, impulse noise, intermodulation distortion, PCM, phase jitter, and random noise to be viewed and controlled.

The **IMPAIRMENTS B→A** key selects the impairments menu group for the simulated channel that provides a transmission path from station B to station A. This menu group allows transmission parameters such as signal level, frequency shift, gain/delay distortion, impulse noise, intermodulation distortion, PCM, phase jitter, and random noise to be viewed and controlled.

The **CENTRAL OFFICE** key selects the menu group that contains network configuration parameters, switched network signaling parameters, and echo simulation parameters.

The **MEASURE** key provides access to the system's measurement and monitoring function. The measure menu allows measurement of signal levels, selection of the signal to be measured, and monitors received DTMF or dial pulse digits.

The **CONFIG** key selects the CONFIG menu. This menu displays the software version and diagnostic status, controls the edit mode for the impairment menus, the configuration of the remote control interface, and selects the configuration of the Intermodulation Distortion (IMD) impairment generator.

The **RECALL** key selects the RECALL menu, which loads TAS defined or user defined parameter profiles.

The **SAVE** key selects the SAVE menu. This saves all impairment and central office parameters in nonvolatile RAM for recalling at a later time.

The **MENU NAVIGATION (ARROW)** keys, located to the right side of the display, are used to scroll between lines using the up and down arrow keys or between fields (or digit positions) within a menu line with the left and right arrow keys.

The **VALUE (+ and -)** keys allow you to edit parameter values.

The **SUBMENU DOWN ARROW** key selects the next menu down in the hierarchy of the selected menu group. The **CENTRAL OFFICE** and **IMPAIRMENTS** menu have submenus to accommodate the numerous parameters

that are available. In a submenu, a “^” will be located at the right corner of the display. This symbol distinguishes a submenu from a main menu.

The **SUBMENU UP ARROW** key selects the next menu up in the hierarchy of the selected menu group. The **CENTRAL OFFICE** and **IMPAIRMENTS** menu groups have submenus to accommodate the numerous parameters that are available to you. If you are in a submenu, you will see a “^” located at the right corner of the display. This symbol distinguishes a submenu from a main menu.

The **VOLUME UP ARROW** key increases the audible level of the built-in audio monitor.

The **VOLUME DOWN ARROW** key decreases the audible level of the built-in audio monitor.

The **AC POWER SWITCH** is located at the lower right-hand corner of the front panel. When this switch is off, the system maintains the current system status in battery-backed memory.

A→B and B→A INPUT AGC keys are located to the left of the main display to provide direct access to the input AGC function for both channels. The invoked button causes the network emulator to measure the transmit signal level that is present at the input of the associated channel. The results of this measurement are then used to configure the channel's input level control circuit by forcing the present INLVL (nominal input level setting) to be equal to the measured transmit level. A small circle is placed above the INLVL value in the associated impairments menu to indicate that an input AGC has been performed and that the displayed nominal input level has been overridden. While the actual effective INLVL setting is modified the currently displayed value is not modified as a result of the AGC. Input AGC is typically used when you do not know the transmit level that is being input into the network emulator. Please refer to section 2.3 for more information.

The **BYPASS** keys allow you to quickly disable all channel impairments and level control in either the A→B or B→A direction. The bypass function is active when the LED beside the button is lit.

A→B and B→A OUTPUT AGC keys are located to the left of the main display to provide direct access to the output AGC function for both channels. The invoked button causes the network emulator to measure the receive signal level that is present at the output of the associated channel. The results of this measurement are then used to configure the channel's output attenuator circuit by forcing an adjustment to the effective output level to equate it to the displayed value of OUTLVL (output level). The output AGC functions causes the operations associated with an input AGC to be performed before the output level

is adjusted. The menu line for OUTLVL will indicate that an output AGC has been performed by placing a small circle above the OUTLVL value in the associated impairments menu. Output AGC is typically used when it is necessary to control the total RMS received signal power at the output of the channel. Please refer to section 2.3 for more information.

The **REMOTE** key enables/disables remote control operation. When remote operation is enabled, menu parameters cannot be changed from the front panel. However, the menu navigation keys can still be used to view parameter values.

Front Panel Displays and Indicators

The **MAIN DISPLAY** located in the center of the front panel shows all control menus and level measurement results.

The **STATUS MONITOR LEDs** are located at the left side of the front panel. This status monitor displays the network simulation mode (Private 4-Wire, Private 2-Wire, and Switched 2-Wire) and the switched 2-wire call progress status. Refer to section 3.2.1 for more information.

1.4.2. Rear Panel Description

Figure 1-8 shows the rear panel of the TAS 100 Series. The rear panel contains the AC power entry module, a fan, 4 terminal strips, a monitor BNC connector, RS-232C and IEEE-488 remote control interfaces, and four RJ-45 type receptacles along with two rocker switches. Refer to section 3.2 for more detail information.

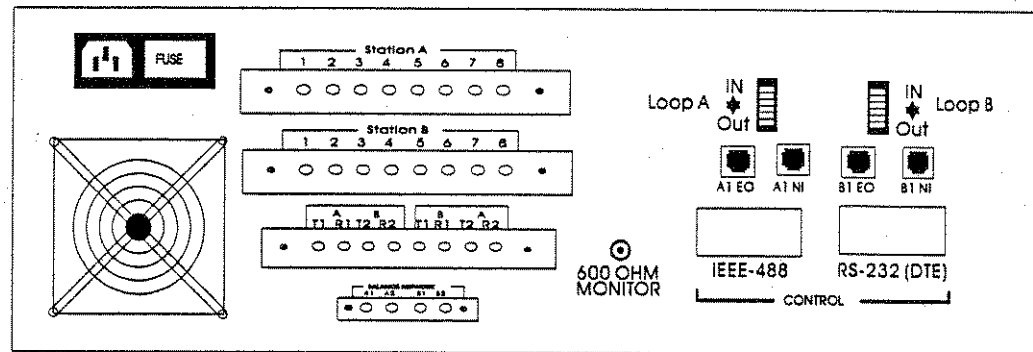

Figure 1-8. TAS 100 Series Rear Panel

Signal Input/Output Connectors

STATION A and B terminal strips are located to the right of the fan and AC entry module. These terminal strips provide signal access to the TAS 100 Series and are directly connected to the front panel 8 position modular telephone jacks.

The **EXTERNAL A → B** and **EXTERNAL B → A** channel terminal strips are located to the right of the fan and AC entry module just below the Station B terminal strip. The signals from the 4 wire channel (A to B or B to A direction) are available on this terminal strip when the TAS 100 SERIES is operating in 2 wire mode. When the feature is enabled, the designated signal path through the TAS 100 Series is completely broken to allow the insertion of external impairments to the signal. The output of the TAS 100 Series transmission channels are provided on the pins labeled "T1" and "R1", and the input signal should be provided back into the TAS 100 Series on the pins labeled "T2" and "R2". The nominal signal level at the output pins will be the output level currently set for the associated channel. The level of the input signal returned to the TAS 100 Series will determine the 2 wire output level at the station A jack for the External B → A Channel and the station B jack for the External A → B Channel.

The **BALANCE NETWORK** is the lower most terminal strip located to the right of the fan and AC entry module. This terminal strip provides the means to substitute other hybrid balancing impedances for those internal to the TAS 100 Series. Nominally the TAS 100 Series provides a 604 ohm balance impedance. See section 3.2.2.3 for more information.

The **MONITOR PORT** is provided on the rear panel for monitoring the transmit and receive signals at each station interface. Designated "600 OHM MONITOR" it is located near the center of the rear panel. The TAS 100 Series can be directed to select and provide selected signals at this BNC-type jack for external monitoring. The following signals may be selected:

A→B Channel:

a xmit: transmit level of the equipment connected to station A. This signal is monitored on the four wire side of the hybrid.

b rcv 4w: signal level received at the station B 4-wire point.

b rcv 2w: signal level received at the station B 2-wire point. This signal is monitored on the four wire side of the hybrid.

B→A Channel:

b xmit: transmit level of the equipment connected to station B. This signal is monitored on the four wire side of the hybrid.

a rcv 4w: signal level received at the station A 4-wire point.

a rcv 2w: signal level received at the station A 2-wire point. This signal is monitored on the four wire side of the hybrid.

An audible representation of the selected A → B or B → A signal is available on the internal speaker.

Loop Emulator Interface

The **LOOP A IN/OUT SWITCH** controls the insertion of the 2-wire loop at the station A interface. Setting the rocker switch to the IN position creates an open circuit to allow the loop that is connected between the rear panel A1 EO and A1 NI connectors to be inserted into the transmission path (between the 2 wire port of the 2 to 4 wire hybrid and the station interface connectors). The OUT position removes the loop.

The **A1 EO and A1 NI CONNECTORS** allow an external loop emulator to be inserted into the transmission path of the AC signal at the station A side of the TAS 100 Series. The End Office (EO) end of the loop should be connected to pin 5 (tip) and 4 (ring) of the 8 position A1 EO connector. The Network Interface (NI) end of the loop should be connected to pin 5 (tip) and 4 (ring) of the 8 position A1 NI connector. Use of the A1 EO and A1 NI connectors allow the TAS 100 SERIES to supply loop current and ringing directly to the device at station A without being affected by the characteristics of the loop.

The **LOOP B IN/OUT SWITCH** controls the insertion of the 2-wire loop at the station B interface. Setting the rocker switch to the IN position creates an open

circuit to allow the loop that is connected between the rear panel B1 EO and B1 NI connectors to be inserted into the transmission path (between the 2 wire port of the 2 to 4 wire hybrid and the station interface connectors). The OUT position removes the loop.

The **B1 EO and B1 NI CONNECTORS** allow an external loop emulator to be inserted into the transmission path of the AC signal at the station B side of the TAS 100 Series. The End Office (EO) end of the loop should be connected to pin 5 (tip) and 4 (ring) of the 8 position B1 EO connector.

Remote Control Connectors

The **CONTROL (IEEE 488)** port allows an external GPIB controller to control the TAS 100 Series.

The **CONTROL (RS-232C)** port allows an external computer to provide control of the TAS 100 Series via RS-232 Carriage Return/Line Feed or RS-232 ACK/NAK protocol.

1.5. Quick Start Procedure

To prepare the TAS 100 Series for initial operation, perform the following steps:

1. Unpack the TAS 100 Series shipping carton. The carton should contain a packing list as well as all the items shown on the list.

Please make sure that all parts listed on the packing list are contained in your TAS 100 Series shipping carton. Save the shipping carton and packing materials until you have completed the system installation and initial check. If you must return equipment, please use the original box and packing material.

2. Check each item for physical damage. If any part appears to be damaged, contact the TAS Customer Service department immediately.
3. Read Section 1.4 of this manual.
4. Follow the installation instructions in Section 1.6.
5. Read Sections 2.1 through 2.3 and perform the exercise described in section 2.2.

1.6. Installation

The following information describes the basic steps that should be followed to install the TAS 100 Series.

1. Be sure that the power cord is detached from the TAS 100 Series, and that the power switch at the lower right side of the front panel is in the off position.
2. Check the AC voltage configuration. Locate the AC power receptacle at the upper left side of the rear panel. The selected AC voltage configuration is visible through a plastic door at the right side of the receptacle. This setting should have been factory-set to match your AC power system. Two settings are available: 100 VAC or 240 VAC. The 100 VAC setting supports 100 to 125 VAC, and the 240 VAC setting supports 205 to 250 VAC. Refer to section 3.2.2.8 if the voltage configuration is not correct and must be changed.
3. Plug one end of the AC power cord into the TAS 100 Series, then plug the other end into the AC source.
4. Setup the TAS 100 Series for standalone or for use with loop emulation as described below in sections 1.6.1 and 1.6.2.
5. Set the AC power switch to the on position. The TAS 100 Series now executes its power-up self test and calibration sequence for approximately 30 seconds, while it displays the following message on the MAIN DISPLAY:

SELF TEST/CALIBRATION

If the TAS 100 Series detects an error, it shows the appropriate error message on the main display. If the TAS 100 Series detects no errors it will display the first line of the CENTRAL OFFICE main menu.

Consult Section 2, "Local Operation", for further information. If you intend to use a computer or data terminal to control the TAS 100 Series, also consult Section 4, "Remote Operation".

NOTE: If the TAS 100 Series encounters a failure during its initial diagnostic operation, record the error code displayed on the front panel, and refer to the Error Code section of this manual.

1.6.1. Standalone TAS 100 Series Test Setup

The TAS 100 Series is often used in a standalone configuration in which two voiceband communication devices, such as modems or fax machines are connected to the emulator's station interfaces on the front or rear panel. This setup is illustrated in Figure 1-9 and typically requires the following:

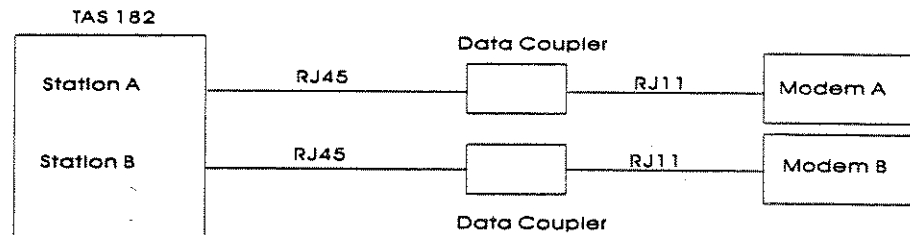

Figure 1-9. Station Interface Interconnect

Signal Interconnect:

1. Connect an 8 position RJ-45 Modular Telephone Cable from the TAS 100 Series Station A Interface to a RJ-45 In Line Data Coupler.
2. Connect a 6 position RJ-11 Modular Telephone Cable from the RJ-45 In Line Data Coupler to communications device "A", typically a reference modem.
3. Connect an 8 position RJ-45 Modular Telephone Cable from the TAS 100 Series Station B Interface to a RJ-45 In Line Data Coupler.
4. Connect a 6 position RJ-11 Modular Telephone Cable from the RJ-45 In Line Data Coupler to communications device "B", typically a modem under test.

CAUTION: Do not plug RJ-11 (6 position plugs) modular telephone plugs directly into the front panel 8 position RJ-45 modular jacks of the TAS 100 Series. The outward 4 pins (1, 2, and 7, 8) of the jack may incur permanent damage.

Loop Emulator Interface Configuration Switch:

5. Set both the LOOP A IN/OUT and the LOOP B IN/OUT switches on the TAS 100 Series rear panel to the "OUT" position to disable the loop emulator interface.

Parameter Settings:

6. Basic installation is complete once the equipment has been setup as described in steps 1 to 5 above. You are now ready to set the parameters of the TAS 100 Series to the values that are needed to conduct the test.

NOTE: Be sure to set the hybrid balance selection appropriately as described in section 3.5.4.1. Internal (600 ohm) is typically selected when no external loop emulation is employed.

1.6.2. TAS 100 Series Test Setup with Loop Emulation (TAS 240)

Test setups for high speed 2 wire modems often require 2 wire loop emulation. The TAS 240 Voiceband Subscriber Loop Emulator (VSLE) provides two-wire loop emulation and hybrid balance network emulation for up to two stations. Primary loop emulation is provided by the main loop (loop A1 or B1) of the TAS 240. This loop is inserted between the 2 wire port of the TAS 100 's hybrid and it's station interface connectors. To accomplish this the End Office (EO) end of the loop is connected to pin 5 (tip) and 4 (ring) of the EO connector and the Network Interface (NI) end of the loop is connected to pin 5 (tip) and 4 (ring) of the NI connector on the TAS 100 Series rear panel. Use of the EO and NI connectors allow the TAS 100 Series to supply loop current and ringing directly to the device at the station interface without being affected by the characteristics of the loop. The hybrid balance emulation is supplied by the tracking loop of the TAS 240 to provide the hybrid of the TAS 100 Series with the best possible match to the impedance of the primary loop. The match between these two impedances will determine the amount of residual echo present at the interface of the TAS 100 Series, the better the match the smaller the echo.

This setup is illustrated in Figure 1-10 and typically requires the following:

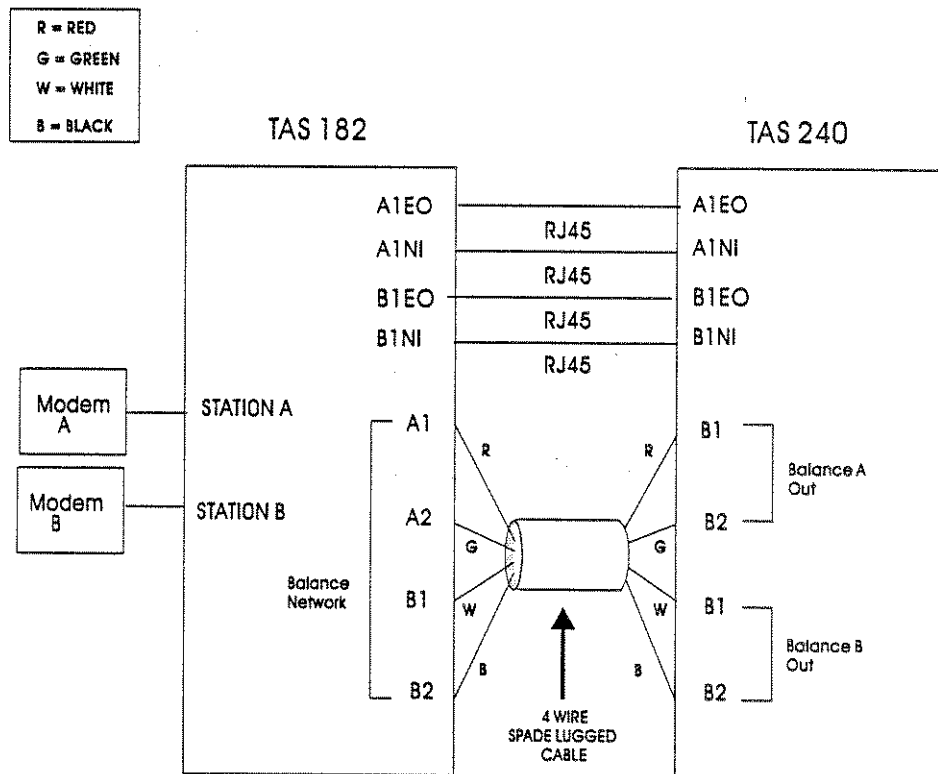

Figure 1-10. Loop Emulator Interconnect

Signal Interconnect:

The following steps of the installation procedure assumes a fully configured TAS 240 (two sets of loops).

1. Perform the signal interconnect as described in steps 1 to 4 in section 1.6.1.
2. Connect an 8 position modular telephone cable from the TAS 240 rear panel A1 EO connector to the A1 EO connector on the rear panel of the TAS 100 Series.
3. Connect an 8 position modular telephone cable from the TAS 240 rear panel A1 NI connector to the A1 NI connector on the rear panel of the TAS 100 Series.
4. Connect an 8 position modular telephone cable from the TAS 240 rear panel B1 EO connector to the B1 EO connector on the rear panel of the TAS 100 Series.
5. Connect an 8 position modular telephone cable from the TAS 240 rear panel B1 NI connector to the B1 NI connector on the rear panel of the TAS 100 Series.

The steps above insert the TAS 240 Main Loops A and B into the 2 wire transmission path between the TAS 100 Series and Modems A & B. The following steps connect the A & B Tracking Loops of the 240 to the hybrid balance ports of the TAS 100 Series.

6. Connect terminal B1 on the TAS 240 rear panel BALANCE A OUT connector to the A1 terminal on the BALANCE NETWORK connector on the rear panel of the TAS 100 Series.
7. Connect terminal B2 on the TAS 240 rear panel BALANCE A OUT connector to the A2 terminal on the BALANCE NETWORK connector on the rear panel of the TAS 100 Series.
8. Connect terminal B1 on the TAS 240 rear panel BALANCE B OUT connector to the B1 terminal on the BALANCE NETWORK connector on the rear panel of the TAS 100 Series.
9. Connect terminal B2 on the TAS 240 rear panel BALANCE B OUT connector to the B2 terminal on the BALANCE NETWORK connector on the rear panel of the TAS 100 Series.

Parameter Settings:

10. Installation is complete once the equipment has been setup as described in steps 1 to 9 on page 21. You are now ready to set the parameters of the TAS 100 Series to the values that are needed to conduct your test.

NOTE: Be sure to set the hybrid balance selection appropriately as described in section 3.5.4. External balance must be selected when an external loop emulation is employed.

2.0. LOCAL OPERATION

2.1. Overview

This chapter describes how to operate the TAS 100 Series from the front panel. This chapter contains information that you will need if you are using the TAS 100 from the front panel.

The TAS 100 Series provides two control options: Local and Remote. For local control, the front panel keys and display are used to set up and execute tests. For remote control, you must attach a computer or terminal to one of the TAS 100 Series' control interfaces (RS-232 or GPIB), and use the computer or terminal to set up and execute tests. This section of the manual describes the TAS 100 local operations. For more information on remote operations, refer to section 4.0, "Remote Operation".

For local operation, the REMOTE indicator must be off. This indicator and the REMOTE key are located at the lower left of the TAS 100 front panel. If the REMOTE indicator is on, press the REMOTE key to turn it off.

Some of the sections or items in this chapter apply only to certain model(s) of the TAS 100 family. The notation [*model, ...*] indicates that the section or item only applies to the model(s) listed inside the brackets. Otherwise, the section applies to all TAS 100 family models.

2.2. Getting Started

This section explains step by step how to perform local control of some of the basic features of the TAS 100 Series. It is intended to familiarize the user with the local control through two examples. For more information on each menu and control key, refer to section 2.3, "Menu Overview".

The first example guides the user through a series of simple local control operations to perform a parameter file recall. The second example shows the user how to change certain system parameters and then how to save the parameter configuration as a user defined file for later use.

2.2.1. Recalling Predefined Test Configurations

The TAS 100 Series provides a set of predefined central office configurations for many countries, as well as transmission impairments configurations according to published Electronic Industries Association (EIA) specifications. These configurations are stored in ROM and can be recalled as often as needed.

When recalling predefined parameter configuration files, the user has the option to recall only the "Central Office" parameters ("CO only"), or both the "Central Office" parameters and "Impairment" parameters ("CO+IMP") of that configuration. For more information on which parameters are considered "Central Office" parameters, and which are considered "Impairment" parameters, refer to section 8.2. Section 8.2 also lists the available configuration files and their parameter settings.

By recalling any one of the predefined parameter configurations, the TAS 100 Series can be configured for testing within seconds. Data communication devices can then be tested according to these specified standards. These predefined configurations can be easily recalled from the front panel by following the steps:

1. Select the Recall menu by pressing the **RECALL** key on the front panel. The Recall menu will appear on the front panel display as shown below:

RECALL:	CO+IMP	file 0
---------	--------	--------

NOTE: The current parameter settings “CO+IMP” and “file 0” maybe different from what is actually shown on the front panel display.

Skip to Step 5 if “CO+IMP” is shown on the display.

2. If the parameter “CO only” is shown instead of “CO+IMP”, move the blinking cursor from “file 0” to the “CO only” field by pressing the **Menu Navigation Left Arrow** key.

RECALL:	<u>C</u> O only	file 0
---------	-----------------	--------

3. Change the parameter “CO only” to “CO+IMP” by pressing the **VALUE +** key. The menu should now look as follows:

RECALL:	<u>C</u> O+IMP	file 0
---------	----------------	--------

4. Now move the blinking cursor back to “file 0” by pressing the **Menu Navigation Right Arrow** key:

RECALL:	CO+IMP	file 0
---------	--------	--------

5. Change the configuration file parameter to the desired one (“USA average” in this example) using the **VALUE +** or **VALUE -** key. You can experiment with changing the parameter value using these keys before carrying on to the next step. We will choose “USA average” as our desired parameter configuration file here.

RECALL:	CO+IMP	<u>U</u> SA average
---------	--------	---------------------

6. Execute the recall by pressing the **RECALL** key again. The front panel will display:

RECALLED FROM USA average

Indicating a successful configuration recall from the USA average file.

7. Press the **RECALL** key one more time to return to the Recall menu:

RECALL:	CO+IMP	<u>U</u> SA average
---------	--------	---------------------

The TAS 100 Series is now configured with the TAS defined USA average parameter values.

2.2.2. Defining and Saving Custom Test Configurations

In addition to predefined parameter configuration files, the TAS 100 Series can save up to five (file 0 to file 4) user defined configurations. These user defined (SAVE) configuration files can also be recalled in the same manner as described in section 2.2.1, "Recalling Predefined Test Setups".

Defining a custom test setup can easily be done by first recalling the predefined configuration that is closest to the desired setup, and then adjust those parameters that are different from the desired configuration.

A mixture of predefined parameter configurations can be used simply by first performing a "CO+IMP" recall of the configuration containing the impairment parameters that you need and then perform a "CO only" file recall of the configuration containing the desired central office parameters. For example, you can define a configuration using the "USA worst case" impairment parameters with "Great Britain" central office parameters by recalling "USA worst case" with "CO+IMP" and then recalling "Great Britain" with "CO only". With this approach the central office parameters will be set according to Great Britain parameters while leaving the impairment parameters as defined in the USA worst case profile. You can then make additional adjustments to further customize your setup.

After all the adjustments are made, the existing setup can be saved to one of the user files: file 0, file 1, file 2, file 3, or file 4. This setup can be recalled as described in section 2.2.1.

CAUTION: Any previous configuration in the file will be overwritten by the existing setup upon a save operation to the file.

The following is an example of defining and saving a user defined parameter configuration that is based on the factory default configuration:

1. Recall the "factory default" configuration as described in the previous section.
2. Select the first line of the Central Office menu by pressing the **Central Office** key twice, the first line of the Central Office Main Menu will be shown on the display as below:

```
LINE MODE:          private 4w
```

3. Change the line mode parameter to switched 2w by pressing the **Value + key**:

```
LINE MODE:          switched 2w
```

4. Select the first line of the A→B impairment menu by pressing the **A→B** key twice

LINE: flat	NOISE:off	32.0dBm
------------	-----------	---------

NOTE: For model 150, or model 151 and 181 with simulation direction set to B→A, this menu line will not be available. Skip directly to step 6. The first menu line will be the one shown in step 6.

5. Press the **Menu Navigation Down Arrow** key to get to the next menu line as shown below:

INLVL:	-10.0dBm	OUTLVL:	-18.0dBm
--------	----------	---------	----------

6. Change the value of the input level down to -15.4dBm as follows:

Use the **Value -** key to change the value of the digit that the cursor has underlined, in this case from a 0 to 4. the input level should now read -10.4dBm:

INLVL:	-10.4dBm	OUTLVL:	-18.0dBm
--------	----------	---------	----------

Use the **Menu Navigation Left Arrow** key to move the cursor to the next position. Again use the **Value -** key to adjust the value until the input level reads -15.4dBm:

INLVL:	-15.4dBm	OUTLVL:	-18.0dBm
--------	----------	---------	----------

7. Move the cursor to the output level parameter field using the **Menu Navigation Right Arrow** key (4 times in this case):

INLVL:	-15.4dBm	OUTLVL:	-18.0dBm
--------	----------	---------	----------

Adjust the output level as described in step 6 until the output level is set to -21.2 dBm:

INLVL:	-15.4dBm	OUTLVL:	-21.2dBm
--------	----------	---------	----------

Practice changing these parameter values and cursor control before moving on to the next step.

8. To save this new custom configuration to a user file, first select the Save menu by pressing the **SAVE** key:

SAVE:	file 0
-------	--------

9. Select the user file that you want to save the current configuration to by using the **Value +** or **Value -** key. Previous configuration of the file will be overwritten. For this example, we will save this configuration to file 1:

SAVE: file 1

10. Execute the save operation by pressing the **SAVE** key. The front panel will now display:

SAVED TO file 1

11. Press the **SAVE** key again to return to the Save menu:

SAVE: file 1

This custom parameter configuration is now saved to file 1 and can be recalled in the same manner as any other predefined configuration.

2.3. Menu Overview

The TAS 100 Series provides a convenient and easy to use menu structure that gives easy access to all of its functions. This section will give you instructions on navigating through the TAS 100 Series menu structure using the keys on the front panel. You will also find specific information about the different menus which appear in the TAS 100 Series' main display.

2.3.1. Menu Summary

There are seven menu groups in the TAS 100 Series; IMPAIRMENTS A→B, IMPAIRMENTS B→A, CENTRAL OFFICE, MEASURE, CONFIG, SAVE, and RECALL. Each of these menu groups is represented by a key on the TAS 100 Series' front panel. For example, to access the CONFIG menu group, press CONFIG. The indicator next to the key will light to indicate the current menu group. These menu groups organize the TAS 100's functionality so that you can find the features easily. Once you become familiar with the TAS 100 Series' menu structure, you will find it easy to use.

The **IMPAIRMENTS A→B** menu group controls the simulated channel that provides a transmission path from station A to station B. This menu group allows transmission parameters such as signal level, frequency shift, gain/delay distortion, impulse noise, intermodulation distortion, PCM, phase jitter, and random noise to be viewed and controlled.

The **IMPAIRMENTS B→A** menu group controls the simulated channel that provides a transmission path from station B to station A. This menu group allows transmission parameters such as signal level, frequency shift, gain/delay distortion, impulse noise, intermodulation distortion, PCM, phase jitter, and random noise to be viewed and controlled.

The IMPAIRMENTS A→B and B→A menu group for the different TAS 100 models are arranged as follow:

Model 150:

A→B and B→A IMPAIRMENTS (Main Menu)

INLVL:	-10.0dBm	OUTLVL:	-23.0dBm
--------	----------	---------	----------

Model 151 and 152:

A→B and B→A IMPAIRMENTS (Main Menu)

LINE:	<i>m1025</i>	NOISE:	<i>on</i>	<i>35.0dBm</i>
INLVL:	<i>-10.0dBm</i>	OUTLVL:	<i>-23.0dBm</i>	
SATELLITE DELAY:	<i>off</i>		<i>550.000ms</i>	
PCM:	<i>off</i>	CODING:	<i>mu-law</i>	RBS: <i>off</i>

A→B and B→A IMPAIRMENTS (Submenu)

CUSTOM LINE: GAIN TYPE	<i>flat</i>	^
CUSTOM LINE: DELAY TYPE	<i>flat</i>	^
NOISE LEVEL CORRECTION:	<i>c-msg</i>	^

Model 181:

A→B and B→A IMPAIRMENTS (Main Menu)

LINE:	<i>m1025</i>	NOISE:	<i>on</i>	<i>35.0dBm</i>
INLVL:	<i>-10.0dBm</i>	OUTLVL:	<i>-23.0dBm</i>	
IMD:	<i>off</i>	2nd	<i>52.0dB</i>	3rd <i>50.0dB</i>
FREQ SHIFT:	<i>off</i>		<i>0.00Hz</i>	
PJ:	<i>off</i>	LVL	<i>0.0deg</i>	FREQ <i>60.00Hz</i>
SATELLITE DELAY:	<i>off</i>		<i>550.000ms</i>	
PCM:	<i>off</i>	CODING:	<i>mu-law</i>	RBS: <i>off</i>
GHIT:	<i>off</i>	LVL	<i>3.0dB</i>	INT <i>1.0s</i>
GHIT:		DUR	<i>5ms</i>	RISE <i>0.2ms</i>
PHIT:	<i>off</i>	LVL	<i>45.0deg</i>	INT <i>1.0s</i>
PHIT:		DUR	<i>5ms</i>	RISE <i>0.2ms</i>
IMP:	<i>off</i>	LVL	<i>40.0dB</i>	rel <i>27.0dBm</i>
IMP:		INT	<i>1.0s</i>	

A→B and B→A IMPAIRMENTS (Submenu)

CUSTOM LINE: GAIN TYPE	<i>flat</i>	^
CUSTOM LINE: DELAY TYPE	<i>flat</i>	^
NOISE LEVEL CORRECTION:	<i>c-msg</i>	^
IMD MODE:	<i>expansive</i>	^

Model 182:**A→B and B→A IMPAIRMENTS (Main Menu)**

LINE:	<i>m1025</i>	NOISE:	<i>on</i>	<i>35.0dBm</i>
INLVL:	<i>-10.0dBm</i>	OUTLVL:	<i>-23.0dBm</i>	
IMD:	<i>off</i>	2nd	<i>52.0dB</i>	3rd <i>50.0dB</i>
FREQ SHIFT:	<i>off</i>	<i>0.00Hz</i>		
AJ:	<i>off</i>	LVL	<i>10.0%</i>	FREQ <i>60.00Hz</i>
PJ:	<i>off</i>	LVL	<i>0.0deg</i>	FREQ <i>60.00Hz</i>
SATELLITE DELAY:	<i>off 550.000ms</i>			
PCM:	<i>off</i>	LINKS	<i>1</i>	CODING <i>mu-law</i>
PCM:		RBS	<i>off</i>	POSITION <i>last</i>
GHIT:	<i>off</i>	LVL	<i>3.0dB</i>	INT <i>1.0s</i>
GHIT:		DUR	<i>5ms</i>	RISE <i>0.2ms</i>
PHIT:	<i>off</i>	LVL	<i>45.0deg</i>	INT <i>1.0s</i>
PHIT:		DUR	<i>5ms</i>	RISE <i>0.2ms</i>
IMP:	<i>off</i>	LVL	<i>40.0dB</i>	rel <i>27.0dBm</i>
IMP:		INT	<i>1.0s</i>	
SFI:	<i>off</i>	LVL	<i>10.0dB</i>	FREQ <i>2600Hz</i>

A→B and B→A IMPAIRMENTS (Submenu)

CUSTOM LINE: GAIN TYPE	<i>flat</i>	<i>^</i>
CUSTOM LINE: DELAY TYPE	<i>flat</i>	<i>^</i>
NOISE LEVEL CORRECTION:	<i>c-msg</i>	<i>^</i>
IMD MODE:	<i>expansive</i>	<i>^</i>

The **CENTRAL OFFICE** menu group contains network configuration parameters, switched network signaling parameters, and echo simulation parameters. The **CENTRAL OFFICE** menu group is arranged as follow:

CENTRAL OFFICE (Main Menu)

LINE MODE:	<i>switched 2w</i>	
STATION A#:	<i>1</i>	
STATION B#:	<i>2</i>	
LOOP CURRENT: A	<i>32mA</i>	B <i>32mA</i>
RINGING: LEVEL	<i>75V</i>	FREQ <i>25.0Hz</i>
DIAL TONE LEVEL:	<i>-10dBm</i>	
REVERSE POLARITY SIGNALLING:	<i>off</i>	
SIMULATION DIRECTION:	<i>A to B</i>	

¹ This menu item applies only to models 151 and 181.

CENTRAL OFFICE (Submenu 1)

LOOP CURRENT POL:	A <i>pos</i>	B <i>pos</i>	^
LOOPBACK RELAY:	A <i>on</i>	B <i>on</i>	^
PROGRAM RESISTOR:	A <i>off</i>	B <i>off</i>	^
EXTERNAL 2W:	A>B <i>no</i>	B>A <i>no</i>	^
BALANCE NETWORK:	A <i>int</i>	B <i>int</i>	^

CENTRAL OFFICE (Submenu 2)

DIAL TONE DELAY:	<i>100ms</i>		^
SWITCHING DELAY:	<i>100ms</i>		^
ON HOOK DELAY:	<i>200ms</i>		^
DISCONNECT SIG:	<i>none</i>	DLY	<i>1ms</i> ^

CENTRAL OFFICE (Submenu 3)

RINGBACK:	F1 <i>450.0Hz</i>	F2 <i>450.0Hz</i>	^
DIAL TONE:	F1 <i>450.0Hz</i>	F2 <i>450.0Hz</i>	^
BUSY:	F1 <i>450.0Hz</i>	F2 <i>450.0Hz</i>	^

CENTRAL OFFICE (Submenu 4)

CADENCE RESOLUTION:	<i>50ms</i>		^
RING:	ON1 <i>0ms</i>	OFF1 <i>0ms</i>	^
RING:	ON2 <i>0ms</i>	OFF2 <i>0ms</i>	^
RING:	ON3 <i>1000ms</i>	OFF3 <i>3000ms</i>	^
BUSY:	ON <i>150ms</i>	OFF <i>150ms</i>	^
DIAL:	ON1 <i>0ms</i>	OFF1 <i>0ms</i>	^
DIAL:	ON2 <i>0ms</i>	OFF2 <i>0ms</i>	^
DIAL:	ON3 <i>10000ms</i>	OFF3 <i>0ms</i>	^
PULSE BREAK:	MIN <i>10ms</i>	MAX <i>90ms</i>	^
PULSE MAKE:	MIN <i>10ms</i>	MAX <i>90ms</i>	^

CENTRAL OFFICE (Submenu 5)

A ECHO:	<i>off</i>	NEAR <i>21.0dB</i>	POL <i>pos</i>	^
A ECHO:		FAR <i>21.0dB</i>	POL <i>pos</i>	^

The **MEASURE** menu group controls the system's measurement and monitoring function. The measure menu allows the measurement of signal levels, select the signal to be measured, and monitor received DTMF or dial pulse digits. The measure menu group is as follows:

MEASURE

LEVEL =	-----dBm	SOURCE	<i>a rcv 2w</i>
STA = <i>a</i>	RCVED #=	-----	

The **CONFIG** menu group displays the software version and diagnostic status, controls the edit mode for the impairment menus, the configuration of the remote control interface and selects the configuration of the Intermodulation Distortion (IMD) impairment generator. The CONFIG menu group arrangement is as follows

SYSTEM CONFIGURATION

STATUS:	<i>okay</i>			
SYSTEM MODEL:	<i>182</i>	SW VER	<i>4.10</i>	
¹ IMPAIRMENT CONTROL:	<i>independent</i>			
REMOTE PROTOCOL:	<i>ieee 488</i>			
RS232:RATE	<i>9600</i>	CHAR	<i>7</i>	STOP <i>1.0</i>
RS232:PARITY	<i>odd</i>	ADDRESS	<i>1</i>	
IEEE 488:ADDRESS	<i>1</i>			
² IMD OPTION:	<i>Standard (TAS 1010)</i>			

The **RECALL** menu group allows you to load TAS defined parameter profiles. The RECALL menu group is as follows:

RECALL

RECALL:	CO+IMP	factory default
---------	--------	-----------------

The **SAVE** menu group allows you to save all impairment and central office parameters in nonvolatile RAM for recalling at a later time. The SAVE menu group is as follows:

SAVE

SAVE:	file 2
-------	--------

¹This menu item applies only to models 152 and 182.

²This menu item applies only to models 181 and 182

2.3.2. Control Key Summary

This section describes the set of keys necessary for navigating the TAS 100 Series menu structures.

Menu Group Select Keys

The menu group select keys are: IMPAIRMENTS A→B and B→A keys, the CENTRAL OFFICE key, the MEASURE key, the CONFIG key, the SAVE key, and the RECALL key. Pressing any one of these keys will select that menu group and return to the menu line previously on before leaving that menu group. By pressing a menu group select key for the currently selected menu group, you can return back to the first line of the main menu of that menu group. The menu group arrangement is described in the previous section.

For example, if the CENTRAL OFFICE key is pressed while the central office menu group is selected, the front panel will display the first line of the main menu of the central office group:

LINE MODE: *switched 2w*

SUBMENU Up & Down Keys

The SUBMENU Up/Down keys are used to switch between menus within the same menu group. Switching to the next or previous menu will bring you to the first line of that menu.

For example, if the user is currently in the Main menu of the central office menu group, by pressing the SUBMENU Down key, the user will move down to the Submenu 1 of the central office menu group. The first line of the Submenu is displayed (notice that the menu group is still central office):

LINE MODE: *switched 2w*

SUBMENU DOWN

LOOP CURRENT POL: A pos B pos ^

Menu Navigation Up & Down Arrow Keys

To move between lines of the same menu, the Menu Navigation Up & Down Arrow keys are used. They are located together with the Menu Navigation Left & Right Arrow keys as a group on the right hand side of the front panel display. For example, if the user is on the first line of the central office main menu, and the Menu Navigation Down Arrow key is pressed, the next (second) line of the central office main menu will be displayed:

LINE MODE: switched 2w

Navigation Down Arrow

STATION A#: 1

Menu Navigation Left & Right Arrow Keys

The Menu Navigation Left and Right Arrow Keys move the cursor between parameter fields of the same menu line. These keys are also used to move between digits of a parameter field for adjusting integer or decimal values.

For example:

LINE: <u>m</u> 1025 NOISE: on 35.0dBm

Menu Navigation Right Arrow

LINE: m1025 NOISE: <u>o</u> n 35.0dBm
--

Menu Navigation Right Arrow

LINE: m1025 NOISE: on <u>3</u> 5.0dBm
--

Menu Navigation Right Arrow

LINE: m1025 NOISE: on 3 <u>5</u> .0dBm
--

VALUE + & - Keys

The Value + and - keys are used to adjust the value of the field that is currently underlined by the cursor. The Value + key increments the value of the field while the Value - key decrements the value of the field.

2.4. Setting I/O Levels and I/O Configuration Parameters

This section contains information on setting input and output parameters. It is assumed that the user is familiar with the basic local operations of the TAS 100 Series. If you are not familiar with the local control of the TAS 100 Series, please read sections 2.2. "Getting Started" and 2.3. "Menu Overview" before referring to this section.

The location, definition and range of the I/O parameters are listed in the following sections. The user should be capable of navigating to these parameters as well as adjusting their values.

2.4.1. Combined vs. Independent Control of I/O Levels [152, 182]

The I/O levels of the two impairment channels can be controlled together or independently. This option can be selected through the impairment control parameter in the System Configuration menu as shown below. By setting the impairment control parameter to combined, the I/O levels (as well as other impairment parameters) of the B→A channel will track that of the A→B channel. Further adjustment of the I/O levels will change the I/O levels of both channels. Both the A→B Impairments and B→A Impairments LEDs will be lit, indicating the combined control mode when either one of the impairments menu group is selected.

This control mode is a subset of the impairment control mode. Before setting the control mode, please refer to section 2.5.1. "Combined vs. Independent Control of Channel Impairments" to avoid undesirable results.

SYSTEM CONFIGURATION

STATUS:	<i>okay</i>	SW VER	<i>4.10</i>
SYSTEM MODEL:	<i>182</i>		
IMPAIRMENT CONTROL:		<i>independent</i>	
REMOTE PROTOCOL:	<i>ieee 488</i>		
RS232:RATE	<i>9600</i>	CHAR 7	<i>STOP 1.0</i>
RS232:PARITY	<i>odd</i>	ADDRESS	<i>1</i>
IEEE 488:ADDRESS	<i>1</i>		
IMD OPTION:	<i>Standard (TAS 1010)</i>		

IMPAIRMENT CONTROL

Definition

Sets the impairment control mode of the TAS 100.

Value Range

independent, combined

2.4.2. Setting Nominal Input Level

The nominal input level setting is located in the main menu of the IMPAIRMENTS menus as shown below. For the exact location of this menu line for the different models, refer to section 2.3.1. See section 3.3.3. for more information on nominal input level.

A->B and B->A IMPAIRMENTS (Main Menu)	
INLVL: 10.0dBm	A→B and B→A

INLVL

Definition

Sets the nominal input level of either the A→B or B→A channel.

Value Range

-23.0 to 7.0 dBm

2.4.3. Executing an Input AGC

Two front panel keys are dedicated to the input AGC function for the TAS 100 Series. They are located to the left of the main display. Before performing an input AGC for the A→B (or B→A) channel, make sure that the call is connected and that the DCE stations are transmitting and configured correctly. To perform an input AGC, press the A→B (or B→A) Input AGC key. The TAS 100 Series will response with "INPUT AGC IN PROGRESS..." on the main display.

If the input AGC is successful, a small circle will appear on top of the input level parameter (INLVL) of the A→B (or B→A) channel indicating an input AGC was performed and that the value may no longer be valid. If an error occurs during the operation, the TAS 100 Series will report the error and wait until the user presses a key to continue. See section 3.3.3. for more information on input AGC.

2.4.4. Setting the Output Level

The output level setting is located in the main menu of the IMPAIRMENTS menus as shown below. For the exact location of this menu line for the different models, refer to section 2.3.1. See section 3.3.4. for more information on output level.

A→B and B→A IMPAIRMENTS (Main Menu)	
INLVL: 10.0dBm	OUTLVL: -23.0dBm

OUTLVL

Definition

Sets the output level of either the A→B or B→A channel.

Value Range

-50.0 to 0.0 dBm

2.4.5. Executing an Output AGC

Two front panel keys are dedicated to the output AGC function for the TAS 100 Series. They are located to the left of the main display. Before performing an output AGC for the A→B (or B→A) channel, make sure that the call is connected and that the DCE stations are transmitting and configured correctly. To perform an output AGC, press the A→B (or B→A) Output AGC key. The TAS 100 Series will respond with "OUTPUT AGC IN PROGRESS..." on the main display.

If the output AGC is successful, a small circle will appear on top of the input level parameter (INLVL) and the output level parameter (OUTLVL) of the A→B (or B→A) channel indicating an output AGC was performed. If an error occurs during the operation, the TAS 100 Series will report the error and wait until the user presses a key to continue. See section 3.3.4. for more information on output AGC.

2.4.6. Controlling Channel Bypass

Two front panel buttons are used for the bypass function. They are located to the left of the LCD display and are grouped together with the input AGC and output AGC buttons. The bypass function allows you to quickly disable all impairments in either direction of transmission.

To enable the bypass function, press the Bypass key of the desired channel(s). The LEDs next to these buttons inform the user of the status of the bypass function. A lit LED indicates the bypass function is in effect for that channel.

2.5. Setting Channel Impairments

This section contains information on setting channel impairments parameters. It is assumed that the user is familiar with the basic local operations of the TAS 100 Series. If you are not familiar with the local control of the TAS 100 Series, please read sections 2.2. "Getting Started" and 2.3. "Menu Overview" before referring to this section.

The location, definition and range of the channel impairments parameters are listed in the following sections. The user should be capable of navigating to these parameters as well as adjusting their values.

2.5.1. Combined vs. Independent Control of Channel Impairments [152, 182]

There are two modes of control for the channel impairments parameters both independent and combined. The independent mode allows the user to program the impairments parameters of the two channels separately. The combined mode allows the user to program the two channels as one set of parameters. By setting the control mode to combined, the B→A impairments parameters automatically tracks those of the A→B direction.

CAUTION: The impairments parameters, including the I/O levels of the B→A channel will be overwritten by the A→B impairments parameters once the control is set to combined. Subsequent adjustments of any parameter will affect both channels.

Both the A→B, and B→A Impairments LEDs will be lit to indicate the combined mode when either one of the impairments menu group is selected.

SYSTEM CONFIGURATION

STATUS:	<i>okay</i>	SW VER	<i>4.10</i>
SYSTEM MODEL:	<i>182</i>		
IMPAIRMENT CONTROL:	<i>independent</i>		
REMOTE PROTOCOL:	<i>ieee 488</i>		
RS232:RATE	<i>9600</i>	CHAR 7	STOP <i>1.0</i>
RS232:PARITY	<i>odd</i>	ADDRESS	<i>1</i>
IEEE 488:ADDRESS	<i>1</i>		
IMD OPTION:	<i>Standard (TAS 1010)</i>		

IMPAIRMENT CONTROL**Definition**

Sets the impairment control mode of the TAS 100.

Value Range

independent, combined

2.5.2. Setting Simulation Direction [151, 181]

For single direction impairments models, the user has the option to put the impairments in either one of the simulation directions. The menu parameter to set this parameter is shown below. See section 3.3.2. for more information on simulation direction.

CENTRAL OFFICE (Main Menu)

LINE MODE:	<i>switched 2w</i>
STATION A#:	<i>1</i>
STATION B#:	<i>2</i>
LOOP CURRENT:	A <i>32mA</i> B <i>32mA</i>
RINGING:	LEVEL <i>75V</i> FREQ <i>25.0Hz</i>
DIAL TONE LEVEL:	<i>-10dBm</i>
REVERSE POLARITY SIGNALLING:	<i>off</i>
SIMULATION DIRECTION A to B	

SIMULATION DIRECTION**Definition**

Sets the impairment simulation direction of the TAS 100.

Value Range

A to B, B to A

2.5.3. Setting Gain/Delay Distortion Parameters [151, 152, 181, 182]

Gain and delay distortion parameters are located in both the main menu and submenu of the IMPAIRMENTS menus as shown below. For the exact locations of these menu lines for the different models, refer to section 2.3.1. See section 3.3.5. for more information on gain/delay distortion parameters.

A→B and B→A IMPAIRMENTS (Main Menu)

LINE: <i>m1025</i>	NOISE: <i>on 35.0dBm</i>
--------------------	--------------------------

A→B and B→A IMPAIRMENTS (Submenu)

CUSTOM LINE: GAIN TYPE <i>flat</i>	^
CUSTOM LINE: DELAY TYPE <i>flat</i>	^

LINE

Definition

Simultaneously selects both the gain verses frequency and delay verses frequency characteristic of the TAS 100 Series.

Value Range

40 selections

CUSTOM LINE GAIN TYPE

Definition

Selects the gain verses frequency characteristics independent of the delay verses frequency characteristic when LINE is set to CUSTOM.

Value Range

35 selections

CUSTOM LINE DELAY TYPE

Definition

Selects the delay verses frequency characteristics independent of the gain verses frequency characteristic when LINE is set to CUSTOM.

Value Range

33 selections

2.5.4. Setting White Noise Parameters [151, 152, 181, 182]

White noise parameters are located in both the main menu and submenu of the IMPAIRMENTS menus as shown below. For the exact locations of these menu lines for the different models, refer to section 2.3.1. See section 3.3.5. for more information on white noise parameters.

A→B and B→A IMPAIRMENTS (Main Menu)

LINE: m1025	NOISE: <i>on</i> 35.0dBm
-------------	--------------------------

A→B and B→A IMPAIRMENTS (Submenu)

NOISE LEVEL CORRECTION: <i>c-msg</i>	^
--------------------------------------	---

STATUS

Definition

Sets status of white noise generator to on or off.

Value Range

on, off

LEVEL

Definition

Sets the level of white noise in units of dBm (dBm = dBm + 90dB).

Value Range

20.0 to 90.0 dBm (-70.0 to 0 dBm)

NOISE LEVEL CORRECTION

Definition

Sets the noise level correction to adjust the level of the noise spectrum to equate the level generated by the TAS 100 Series to the level that would be measured by external measurement equipment that employ the specified input weighting filter. When a correction value is selected the level of all frequency components of the generated noise signal are adjusted.

Value Range

c-msg (C-Message), 3k flat (3kHz Flat), psopho (Psophometric)

2.5.5. Setting Intermodulation Distortion (IMD) Parameters [181, 182]

Intermodulation distortion parameters are located in the IMPAIRMENTS main menu, the IMPAIRMENTS submenu, and the SYSTEM CONFIGURATION menu as shown below. For the exact locations of these menu lines for the different models, refer to section 2.3.1. See section 3.3.5. for more information on intermodulation distortion parameters.

A→B and B→A IMPAIRMENTS (Main Menu)

IMD:	<i>off</i>	2nd <i>52.0dB</i>	3rd <i>50.0dB</i>
------	------------	-------------------	-------------------

A→B and B→A IMPAIRMENTS (Submenu)

CUSTOM LINE: GAIN TYPE	<i>flat</i>	^
CUSTOM LINE: DELAY TYPE	<i>flat</i>	^
NOISE LEVEL CORRECTION:	<i>c-msg</i>	^
IMD MODE:	<i>expansive</i>	^

SYSTEM CONFIGURATION

STATUS:	<i>okay</i>
SYSTEM MODEL:	<i>182 SW VER 4.10</i>
IMPAIRMENT CONTROL:	<i>independent</i>
REMOTE PROTOCOL:	<i>ieee 488</i>
RS232: RATE	<i>9600 CHAR 7 STOP 1.0</i>
RS232: PARITY	<i>odd ADDRESS 1</i>
IEEE 488: ADDRESS	<i>1</i>
IMD OPTION:	<i>Standard (TAS 1010)</i>

STATUS

Definition

Sets status of intermodulation distortion generator to on or off.

Value Range

on, off

2nd (Harmonic Level)

Definition

Sets the second order distortion level.

Value Range

20.0 to 55.0 dB

3rd (Harmonic Level)

Definition

Sets the third order distortion level.

Value Range

20.0 to 55.0 dB

IMD MODE

Definition

Sets the intermodulation distortion mode.

Value Range

expansive, compressive

IMD OPTION

Definition

Sets the mode of operation of the intermodulation distortion impairment.

Value Range

Standard (TAS 1010), Proprietary

2.5.6. Setting Frequency Shift Parameters [181, 182]

Frequency shift parameters are located in the main menu of the IMPAIRMENTS menus as shown below. For the exact location of this menu line for the different models, refer to section 2.3.1. See section 3.3.5. for more information on frequency shift parameters.

A→B and B→A IMPAIRMENTS (Main Menu)

FREQ SHIFT: <i>off</i> <i>0.00Hz</i>

STATUS

Definition

Sets status of frequency shift generator to on or off.

Value Range

on, off

LEVEL

Definition

Sets the level of frequency shift in units of Hz. Notice that the minimum step size of the frequency shift level is 0.25 Hz.

Value Range

-19.75 to 19.75 Hz.

2.5.7. Setting Amplitude Jitter Parameters [182]

Amplitude jitter parameters are located in the main menu of the IMPAIRMENTS menus as shown below. For the exact location of this menu line for the different models, refer to section 2.3.1. See section 3.3.5. for more information on amplitude jitter parameters.

IMPAIRMENTS A→B and B→A (Main Menu)

AJ:	<i>off</i>	LVL 10.0%	FREQ 60.00Hz
------------	------------	------------------	---------------------

STATUS

Definition

Sets status of amplitude jitter generator to on or off.

Value Range

on, off

LVL

Definition

Sets the peak to peak level of amplitude jitter in percent.

Value Range

0.0 to 98.0%

FREQ

Definition

Sets the frequency of amplitude jitter sinusoidal modulation in units of hertz.

Value Range

0.0 to 300.0 hertz

2.5.8. Setting Phase Jitter Parameters [181, 182]

Phase jitter parameters are located in the main menu of the IMPAIRMENTS menus as shown below. For the exact location of this menu line for the different models, refer to section 2.3.1. See section 3.3.5. for more information on phase jitter parameters.

IMPAIRMENTS A→B and B→A (Main Menu)

PJ:	<i>off</i>	LVL <i>0.0deg</i>	FREQ <i>60.00Hz</i>
-----	------------	-------------------	---------------------

STATUS

Definition

Sets status of phase jitter generator to on or off.

Value Range

on, off

LVL

Definition

Sets the peak to peak level of phase jitter in units of degrees.

Value Range

0.0 to 45.0 degrees

FREQ

Definition

Sets the frequency of phase jitter sinusoidal modulation in units of hertz.

Value Range

0.0 to 300.0 hertz

2.5.9. Setting Gain Hits Parameters [181, 182]

Gain hits parameters are located in the main menu of the IMPAIRMENTS menus as shown below. For the exact location of this menu line for the different models, refer to section 2.3.1. See section 3.3.5. for more information on gain hits parameters.

IMPAIRMENTS A→B and B→A (Main Menu)

GHIT:	<i>off</i>	LVL	<i>3.0dB</i>	INT	<i>1.0s</i>
GHIT:	DUR	<i>5ms</i>	RISE	<i>0.2ms</i>	

STATUS

Definition

Sets status of gain hits generator to on or off.

Value Range

on, off

LVL

Definition

Sets the gain hit level in units of 0.1 dB.

Value Range

-20.0 to +6.0 dB.

INT

Definition

Sets the interval between periodic gain hits. This interval must be greater than the duration + risetime.

Value Range

0.1 to 320.0 sec.

DUR

Definition

Sets the gain hit duration in units of 1.0 ms. The duration must be greater than the risetime.

Value Range

1 to 20000 ms.

RISE**Definition**

Sets the gain hit risetime in units of 0.1 ms.

Value Range

0.2 to 990.0 ms.

2.5.10. Setting Phase Hits Parameters [181, 182]

Phase hits parameters are located in the main menu of the IMPAIRMENTS menus as shown below. For the exact location of this menu line for the different models, refer to section 2.3.1. See section 3.3.5. for more information on phase hits parameters.

IMPAIRMENTS A→B and B→A (Main Menu)

PHIT: <i>off</i>	LVL: <i>45.0deg</i>	INT: <i>1.0s</i>
PHIT: <i>off</i>	LVL: <i>5ms</i>	RISE: <i>0.2ms</i>

STATUS**Definition**

Sets status of phase hits generator to on or off.

Value Range

on, off

LVL**Definition**

Sets the phase hit level in units of 0.1 degrees.

Value Range

0.0 to 90.0 degrees.

INT**Definition**

Sets the interval between periodic phase hits. This interval must be greater than the duration + risetime.

Value Range

0.1 to 320.0 sec.

2.5.11. Setting Impulse Noise Parameters [181, 182]

Impulse noise parameters are located in the main menu of the IMPAIRMENTS menus as shown below. For the exact location of this menu line for the different models, refer to section 2.3.1. See section 3.3.5. for more information on impulse noise parameters.

A→B and B→A IMPAIRMENTS (Main Menu)

IMP: <i>off</i>	LVL <i>40.0dB</i>	rel <i>27.0dBm</i>
------------------------	--------------------------	---------------------------

STATUS

Definition

Sets status of impulse noise generator to on or off.

Value Range

on, off

LVL

Definition

Sets the peak level of the the impulse to be generated.

Value Range

0.0 to 55.0 dB below signal level

INT

Definition

Sets the interval between impulse hits.

Value Range

0.1 to 320.0 seconds

2.5.12. Setting PCM Simulation Parameters [151, 152, 181]

PCM simulation parameters are located in the main menu of the IMPAIRMENTS menus as shown below. For the exact location of this menu line for the different models, refer to section 2.3.1. See section 3.3.6. for more information on PCM simulation parameters.

A→B and B→A IMPAIRMENTS (Main Menu)

PCM:	<i>off</i>	CODING:	<i>mu-law</i>	RBS:	<i>off</i>
-------------	------------	----------------	---------------	-------------	------------

STATUS

Definition

Sets status of PCM simulation to on or off.

Value Range

on, off

CODING

Definition

Sets the type of coding for the PCM simulation.

Value Range

mu-law, a-law

RBS

Definition

Sets robbed bit signaling (RBS) on or off for the PCM simulation.

Value Range

on, off

2.5.13. Setting PCM Simulation Parameters [182]

PCM simulation parameters are located in the main menu of the IMPAIRMENTS menus as shown below. For the exact location of this menu line for the different models, refer to section 2.3.1. See section 3.3.6. for more information on PCM simulation parameters.

A→B and B→A IMPAIRMENTS (Main Menu)

PCM:	<i>off</i>	LINKS <i>1</i>	CODING <i>mu-law</i>
PCM:		RBS <i>off</i>	POSITION <i>last</i>

STATUS

Definition

Sets status of PCM simulation to on or off.

Value Range

on, off

LINKS

Definition

Selects the number of PCM links.

Value Range

1 to 3 links

CODING

Definition

Sets the type of coding for the PCM simulation.

Value Range

mu-law, a-law

RBS

Definition

Sets robbed bit signaling (RBS) on or off for the PCM simulation.

Value Range

on, off

POSITION**Definition**

Selects PCM as the first or last position in the impairment generator sequence.

Value Range

first, last

2.5.14. Setting Single Frequency Interference Parameters [182]

Single frequency interference parameters are located in the main menu of the IMPAIRMENTS menus as shown below. For the exact location of this menu line for the different models, refer to section 2.3.1. See section 3.3.5. for more information on single frequency interference parameters.

IMPAIRMENTS A→B and B→A (Main Menu)

SFI:	<i>off</i>	LVL 10.0dB	FREQ 2600Hz
-------------	------------	-------------------	--------------------

STATUS**Definition**

Sets status of single frequency interference generator to on or off.

Value Range

on, off

LVL**Definition**

Sets the peak to peak level of single frequency interference in decibels.

Value Range

0.0 to 50.0dB

FREQ**Definition**

Sets the frequency of single frequency interference in units of hertz.

Value Range

0 to 3400 Hz

2.6. Setting Echo/Satellite Delay Parameters

This section contains information on setting echo and satellite delay parameters. It is assumed that the user is familiar with the basic local operations of the TAS 100 Series. If you are not familiar with the local control of the TAS 100 Series, please read sections 2.2. "Getting Started" and 2.3. "Menu Overview" before referring to this section.

The location, definition and range of the echo and satellite delay parameters are listed in the following sections. The user should be capable of navigating to these parameters as well as adjusting their values.

2.6.1. Setting Near Talker Echo Parameters

Near talker echo parameters are located in submenu 5 of the CENTRAL OFFICE menus as shown below. See section 3.3.7. for more information on near talker echo parameters.

CENTRAL OFFICE (Submenu 5)				
A ECHO:	<i>off</i>	NEAR <i>21.0dB</i>	POL <i>pos</i>	^
A ECHO:		FAR <i>21.0dB</i>	POL <i>pos</i>	^
B ECHO	<i>off</i>	NEAR <i>21.0dB</i>	POL <i>pos</i>	^
B ECHO:		FAR <i>21.0dB</i>	POL <i>pos</i>	^

STATUS (Echo Attenuator)

Definition

Sets status of echo simulation (both near and far echo) to on or off.

Value Range

on, off

NEAR (Attenuation Level)

Definition

Sets the near echo attenuation level.

Value Range

-10.0 to 40.0 dB (i.e. 10.0 dB gain to 40.0 dB attenuation)

POLARITY
Definition

Sets near echo attenuator path polarity (phase).

Value Range

pos, neg

2.6.2. Setting Far Talker Echo/Satellite Delay Parameters

Far talker echo/satellite delay parameters are located in submenu 5 of the CENTRAL OFFICE menus and the main menu of the IMPAIRMENTS menus as shown below. For the exact locations of these menu lines for the different models, refer to section 2.3.1. See section 3.3.7. for more information on far talker echo/satellite delay parameters. **Note: Model 150 is not equipped with Satellite Delay.**

CENTRAL OFFICE (Submenu 5)

A ECHO:	<input type="checkbox"/> off	NEAR 21.0dB	POL pos	^
A ECHO:		FAR 21.0dB	POL pos	^
B ECHO:	<input type="checkbox"/> off	NEAR 21.0dB	POL pos	^
B ECHO:		FAR 21.0dB	POL pos	^

A→B and B→A IMPAIRMENTS (Main Menu)

SATELLITE DELAY:	<input type="checkbox"/> off	550.000ms		
------------------	------------------------------	-----------	--	--

STATUS (Echo Attenuator)
Definition

Sets status of echo simulation (both near and far echo) to on or off.

Value Range

on, off

FAR (Attenuation Level)
Definition

Sets the far echo attenuation level.

Value Range

-20.0 to 30.0 dB (i.e. 20.0 dB gain to 30.0 dB attenuation)

POLARITY

Definition

Sets far echo attenuator path polarity (phase).

Value Range

pos, neg

STATUS (Satellite Delay)

Definition

Sets status of satellite delay simulation to on or off.

Value Range

on, off

DELAY MAGNITUDE

Definition

Sets the magnitude of the satellite (propagation) delay in 0.125 msec steps.

Value Range

0.000 to 1599.875 ms

2.7. Controlling Central Office Emulation

This section contains information on setting central office parameters. It is assumed that the user is familiar with the basic local operations of the TAS 100 Series. If you are not familiar with the local control of the TAS 100 Series, please read sections 2.2. "Getting Started" and 2.3. "Menu Overview" before referring to this section.

The location, definition and range of the central office parameters are listed in the following sections. The user should be capable of navigating to these parameters as well as adjusting their values.

2.7.1. Selecting an Exchange Configuration

The exchange configuration mode is located in the main menu of the CENTRAL OFFICE menus as shown below. See section 3.5.2. for more information on exchange configurations.

CENTRAL OFFICE (Main Menu)

LINE MODE: <i>switched 2w</i>
STATION A#: 1
STATION B#: 2
LOOP CURRENT: A 32mA B 32mA
RINGING: LEVEL 75V FREQ 25.0Hz
DIAL TONE LEVEL: -10dBm
REVERSE POLARITY SIGNALLING: <i>off</i>

LINE MODE

Definition

Selects the exchange configuration (line mode) of the central office emulation.

Value Range

private 4w, switched 2w, private 2w, auto switched 2w, private 4w/switched 2w

2.7.2. Entering Telephone Numbers

Station A and B telephone numbers are located in the main menu of the CENTRAL OFFICE menus as shown below. See section 3.5.7. for more information on telephone numbers.

CENTRAL OFFICE (Main Menu)

LINE MODE: <i>switched 2w</i>
STATION A#: 1
STATION B#: 2
LOOP CURRENT: A 32mA B 32mA
RINGING: LEVEL 75V FREQ 25.0Hz
DIAL TONE LEVEL: -10dBm
REVERSE POLARITY SIGNALLING: <i>off</i>

STATION A (or B)

Definition

Sets the telephone number for station A or station B.

Value Range

Up to 15 digits of 0 to 9, *, # or + .

2.7.3. Entering Loop Current Generator Parameters

Loop current generator parameters are located in the main menu and submenu 1 of the CENTRAL OFFICE menus as shown below. See section 3.5.5 for more information on the loop current generator.

CENTRAL OFFICE (Main Menu)	
LINE MODE:	<i>switched 2w</i>
STATION A#:	<i>1</i>
STATION B#:	<i>2</i>
LOOP CURRENT:	A <i>32 mA</i> B <i>32mA</i>
RINGING:	LEVEL <i>75V</i> FREQ <i>25.0Hz</i>
DIAL TONE LEVEL:	<i>-10dBm</i>
REVERSE POLARITY SIGNALLING:	<i>off</i>

CENTRAL OFFICE (Submenu 1)			
LOOP CURRENT POL:	A <i>pos</i>	B <i>pos</i>	^
LOOPBACK RELAY:	A <i>on</i>	B <i>on</i>	^
PROGRAM RESISTOR:	A <i>off</i>	B <i>off</i>	^
EXTERNAL 2W:	A>B <i>no</i>	B>A <i>no</i>	^
BALANCE NETWORK:	A <i>int</i>	B <i>int</i>	^

LOOP CURRENT

Definition

Sets the loop current level for station A or station B in 8 mA steps.

Value Range

8 to 120 mA

LOOP CURRENT POLARITY

Definition

Sets the loop current polarity for station A or station B.

Value Range

pos, neg

2.7.4. Entering Ringing and Ringback Parameters

Ringing and Ringback parameters are located in the main menu, submenu 3, and submenu 4 of the CENTRAL OFFICE menus as shown below. See section 3.5.6 for more information on the ringing generator.

CENTRAL OFFICE (Main Menu)

LINE MODE: <i>switched 2w</i>
STATION A#: <i>1</i>
STATION B#: <i>2</i>
LOOP CURRENT: A <i>32mA</i> B <i>32mA</i>
RINGING: LEVEL 75V FREQ 25.0Hz
DIAL TONE LEVEL: <i>-10dBm</i>
REVERSE POLARITY SIGNALLING: <i>off</i>

CENTRAL OFFICE (Submenu 3)

RING BACK: F1 450.0Hz	^
DIAL TONE: F1 <i>450.0Hz</i> F2 <i>450.0Hz</i>	^
BUSY: F1 <i>450.0Hz</i> F2 <i>450.0Hz</i>	^

CENTRAL OFFICE (Submenu 4)

CADENCE RESOLUTION: 50ms	^
RING: ON1 0ms OFF1 0ms	^
RING: ON2 0ms OFF2 0ms	^
RING: ON3 1000ms OFF# 3000ms	^
BUSY: ON <i>150ms</i> OFF <i>150ms</i>	^
DIAL: ON1 <i>0ms</i> OFF1 <i>0ms</i>	^
DIAL: ON2 <i>0ms</i> OFF2 <i>0ms</i>	^
DIAL: ON3 <i>10000ms</i> OFF3 <i>0ms</i>	^
PULSE BREAK: MIN <i>10ms</i> MAX <i>90ms</i>	^
PULSE MAKE: MIN <i>10ms</i> MAX <i>90ms</i>	^

RINGING: LEVEL

Definition

Sets the ring level in 1 Vrms steps.

Value Range

1 to 100 Vrms

RINGING: FREQ**Definition**

Sets the ring frequency in units of 0.1 Hz.

Value Range

14.0 to 75.0 Hz

RINGBACK Frequencies**Definition**

Sets the ringback (audible ring) frequencies F1, and F2 for the ringing generator in 0.1 Hz steps.

Value Range

100.0 to 720.0 Hz

CADENCE RESOLUTION**Definition**

Sets the cadence resolution (step size) for signaling tones.

Value Range

25 ms, 50 ms

RING:ON1,2,3 and OFF1,2,3**Definition**

Sets the on time and off time for the ringing generator.

Value Range

0 to 5000 ms if cadence resolution = 25 ms
0 to 10000 ms if cadence resolution = 50 ms

2.7.5. Entering Dial Tone Parameters

Dial tone parameters are located in the main menu, submenu 2, submenu 3, and submenu 4 of the CENTRAL OFFICE menus as shown below. See section 3.5.6. for more information on dial tone parameters.

CENTRAL OFFICE (Main Menu)

LINE MODE: <i>switched 2w</i>
STATION A#: <i>1</i>
STATION B#: <i>2</i>
LOOP CURRENT: A <i>32mA</i> B <i>32mA</i>
RINGING: LEVEL <i>75V</i> FREQ <i>25.0Hz</i>
DIAL TONE LEVEL: -10dBm
REVERSE POLARITY SIGNALLING: <i>off</i>

CENTRAL OFFICE (Submenu 2)

DIAL TONE DELAY:	<i>100ms</i>	^
SWITCHING DELAY:	<i>100ms</i>	^
ON HOOK DELAY:	<i>200ms</i>	^
DISCONNECT SIG:	<i>none DLY 1ms</i>	^

CENTRAL OFFICE (Submenu 3)

RINGBACK:	F1 <i>450.0Hz</i>	F2 <i>450.0Hz</i>	^
DIAL TONE:	F1 <i>450.0Hz</i>	F2 <i>450.0Hz</i>	^
BUSY:	F1 <i>450.0Hz</i>	F2 <i>450.0Hz</i>	^

CENTRAL OFFICE (Submenu 4)

CADENCE RESOLUTION:	<i>50 ms</i>	^	
RING:	ON1 <i>0ms</i>	OFF1 <i>0ms</i>	^
RING:	ON2 <i>0ms</i>	OFF2 <i>0ms</i>	^
RING:	ON3 <i>1000ms</i>	OFF3 <i>3000ms</i>	^
BUSY:	ON <i>150ms</i>	OFF <i>150ms</i>	^
DIAL:	ON1 <i>0ms</i>	OFF1 <i>0ms</i>	^
DIAL:	ON2 <i>0ms</i>	OFF <i>0ms</i>	^
DIAL:	ON3 <i>10000ms</i>	OFF <i>0ms</i>	^
PULSE BREAK:	MIN <i>10ms</i>	MAX <i>90ms</i>	^
PULSE MAKE:	MIN <i>10ms</i>	MAX <i>90ms</i>	^

DIAL TONE LEVEL**Definition**

Sets the dial tone level in units of 1 dB.

Value Range

-40 to 0 dBm

DIAL TONE DELAY**Definition**

Sets the dial tone delay, i.e. the time between station off hook to dial tone, measured in 1 ms steps.

Value Range

2 to 25000 ms

DIAL TONE (Frequencies)**Definition**

Sets the dial tone frequencies F1 and F2 in units of 0.1 Hz.

Value Range

100.0 to 720.0 Hz

CADENCE RESOLUTION**Definition**

Sets the cadence resolution (step size) for signaling tones.

Value Range

25 ms, 50 ms

BUSY: ON and OFF**Definition**

Sets the on time and off time for the busy tone.

Value Range

0 to 5000 ms if cadence resolution = 25 ms

0 to 10000 ms if cadence resolution = 50 ms

2.7.7. Controlling Reverse Battery Polarity Signaling

The reverse battery polarity signaling selection is located in the main menu of the CENTRAL OFFICE menus as shown below. See section 3.5.3. for more information on reverse battery polarity signaling.

CENTRAL OFFICE (Main Menu)

LINE MODE: <i>switched 2w</i>
STATION A#: <i>1</i>
STATION B#: <i>2</i>
LOOP CURRENT: A <i>32mA</i> B <i>32mA</i>
RINGING: LEVEL <i>75V</i> FREQ <i>25.0Hz</i>
DIAL TONE LEVEL: <i>-10dBm</i>
REVERSE POLARITY SIGNALLING: <i>off</i>

STATUS

Definition

Sets the reverse polarity signaling simulation to on or off.

Value Range

on, off

2.7.8. Selecting the Hybrid Balance Network

The hybrid balance parameters are located in the submenu 1 of the CENTRAL OFFICE menus as shown below. See section 3.5.3. for more information on hybrid balance network.

CENTRAL OFFICE (Submenu 1)			
LOOP CURRENT POL:	A <i>pos</i>	B <i>pos</i>	^
LOOPBACK RELAY:	A <i>on</i>	B <i>on</i>	^
PROGRAM RESISTOR:	A <i>off</i>	B <i>off</i>	^
EXTERNAL 2W:	A>B <i>no</i>	B>A <i>no</i>	^
BALANCE NETWORK:	A int	B int	^

BALANCE NETWORK

Definition

Sets the hybrid balance network for station A or station B.

Value Range

int, ext (i.e. internal or external)

2.7.9. Controlling External Access to the 4-Wire Path (External 2W)

The external access to the 4-wire path in 2-wire exchange configuration selections are located in submenu 1 of the CENTRAL OFFICE menus as shown below. See section 3.5.3. for more information on external access to the 4-wire path.

CENTRAL OFFICE (Submenu 1)			
LOOP CURRENT POL:	A <i>pos</i>	B <i>pos</i>	^
LOOPBACK RELAY:	A <i>on</i>	B <i>on</i>	^
PROGRAM RESISTOR:	A <i>off</i>	B <i>off</i>	^
EXTERNAL 2W:	A>B <i>no</i>	B>A <i>no</i>	^
BALANCE NETWORK:	A int	B int	^

EXTERNAL 2W

Definition

Enable or disable the 4-wire path break-out in the A to B or B to A channel.

Value Range

yes, no (i.e. enable, disable)

2.7.10. Controlling the Program Resistor (Programmable Data Jack)

The program resistor parameters are located in submenu 1 of the CENTRAL OFFICE menus as shown below. See section 3.5.3. for more information on program resistor parameters.

CENTRAL OFFICE (Submenu 1)

LOOP CURRENT POL:	A <i>pos</i>	B <i>pos</i>	^
LOOPBACK RELAY:	A <i>on</i>	B <i>on</i>	^
PROGRAM RESISTOR:	A <i>off</i>	B <i>off</i>	^
EXTERNAL 2W:	A>B <i>no</i>	B>A <i>no</i>	^
BALANCE NETWORK:	A <i>int</i>	B <i>int</i>	^

PROGRAM RESISTOR

Definition

Sets the station 2-wire level programming resistor contacts (pin 7 and 8) to open or 866 ohms.

Value Range

on, off (i.e. 866 ohms resistor, open)

2.7.11. Controlling the 4-Wire Configuration Loopback Mode Indicator (MI)

The loopback mode indicator (MI) parameters are located in submenu 1 of the CENTRAL OFFICE menus as shown below. See section 3.5.2. for more information on the loopback mode indicator parameters.

CENTRAL OFFICE (Submenu 1)

LOOP CURRENT POL:	A <i>pos</i>	B <i>pos</i>	^
LOOPBACK RELAY:	A <i>on</i>	B <i>on</i>	^
PROGRAM RESISTOR:	A <i>off</i>	B <i>off</i>	^
EXTERNAL 2W:	A>B <i>no</i>	B>A <i>no</i>	^
BALANCE NETWORK:	A <i>int</i>	B <i>int</i>	^

LOOPBACK RELAY

Definition

Sets the station 4-wire loopback relay contacts to on, or off.

Value Range

on, off (i.e. close, open)

2.7.12. Entering Network Switching Delay and On Hook Delay Parameters

The switching and on hook delay parameters are located in submenu 2 of the CENTRAL OFFICE menus as shown below. See section 3.5.6. for more information on the switching and on hook delay parameters.

CENTRAL OFFICE (Submenu 2)

DIAL TONE DELAY:	<i>100ms</i>			^
SWITCHING DELAY:	100ms			^
ON HOOK DELAY:	200ms			^
DISCONNECT SIG:	<i>none</i>	DLY	<i>1ms</i>	^

SWITCHING DELAY

Definition

Sets the switching delay, i.e. the time between the end of the dialing sequence and the connection of the call, in 1 ms steps.

Value Range

1 to 25000 msec

ON HOOK DELAY

Definition

Sets the on hook recognition delay, i.e. the time from station on hook to recognition of on hook status at the line control unit, in 1 ms steps.

Value Range

1 to 255 msec

2.7.13. Entering Disconnect Signal Parameters

The disconnect signal parameters are located in submenu 2 of the CENTRAL OFFICE menus as shown below. See section 3.5.6. for more information on the disconnect signal parameters.

CENTRAL OFFICE (Submenu 2)

DIAL TONE DELAY:	100ms			^
SWITCHING DELAY:	100ms			^
ON HOOK DELAY:	200ms			^
DISCONNECT SIG:	<i>none</i>	DLY	1ms	^

DISCONNECT SIG: (Tone)

Definition

Selects the tone for disconnect signal.

Value Range

none, busy, dial

DISCONNECT SIG: DLY (Delay)

Definition

Controls the disconnect signal delay in 1 ms steps. Disconnect signal delay is defined as the time from the completion of the on hook delay to the transmission of the disconnect signal. The disconnect signal is sent to the station that remains off hook after a call is terminated in 2 wire switched mode.

Value Range

1 to 30000 ms

2.8. Monitoring Signal Level

This section contains information on how to monitor various signal levels. It is assumed that the user is familiar with the basic local operations of the TAS 100 Series. If you are not familiar with the local control of the TAS 100 Series, please read sections 2.2. "Getting Started" and 2.3. "Menu Overview" before referring to this section.

The location, definition and range of parameters for signal monitoring are listed in the following sections. The user should be capable of navigating to these parameters as well as adjusting their values.

2.8.1. Measuring Signal Level

To measure the signal level with the TAS 100 Series, the source parameter must first be set to the desired signal point. The source parameter for the measure function is located in the MEASURE menu as shown below. The true-rms level measurement of this monitor point will be shown on the same menu line labeled with LEVEL=___ dBm. See section 3.4 for more information on measurement/monitoring.

MEASURE	
LEVEL = -----dBm	SOURCE a rcv 2w
STA = a	RCVED #= -----

SOURCE

Definition

Sets the monitor point for the signal level measurement.

Value Range

a xmit, a rcv 4w, a rcv 2w
 b xmit, b rcv 4w, b rcv 2w

LEVEL

Definition

Shows the signal level at the currently selected monitor point.

Value Range

N/A

2.8.2. Controlling Audio Volume

In addition to the front panel display signal monitor, a built-in audio monitor is also available. The same monitor point is used for the audio monitor as the source parameter selected for the signal level monitor. The source parameter selection is located in the MEASURE menu as shown below.

Two front panel keys are dedicated to adjust the volume of this audio monitor. They are the VOLUME Up and VOLUME Down arrow keys located to the left of the front panel main display. Bringing the volume all the way down will in effect turn off the audio monitor. See section 3.4.2. for more information on the audio monitor.

MEASURE	
LEVEL = -----dBm	SOURCE a rcv 2w
STA = a	RCVED #= -----

SOURCE

Definition

Sets the monitor point for the signal level measurement.

Value Range

a xmit, a rcv 4w, a rcv 2w

b xmit, b rcv 4w, b rcv 2w

2.9. Performing Dialing Analysis

This section contains information on dialing analysis. It is assumed that the user is familiar with the basic local operations of the TAS 100 Series. If you are not familiar with the local control of the TAS 100 Series, please read sections 2.2. "Getting Started" and 2.3. "Menu Overview" before referring to this section.

The location, definition and range of the parameters for the dialing analysis are listed in the following sections. The user should be capable of navigating to these parameters as well as adjusting their values.

2.9.1. Entering Dial Pulse Make/Break Detection Intervals

The dial pulse make/break detection intervals parameters are located in submenu 4 of the CENTRAL OFFICE menus as shown below. See section 3.5.8. for more information on dial pulse make/break detection intervals.

CENTRAL OFFICE (Submenu 4)

CADENCE RESOLUTION:	50ms		^
RING:	ON1 0ms	OFF1 0ms	^
RING:	ON2 0ms	OFF2 0ms	^
RING:	ON3 1000ms	OFF3 3000ms	^
BUSY:	ON 150ms	OFF 150ms	^
DIAL:	ON1 0ms	OFF1 0ms	^
DIAL:	ON2 0ms	OFF2 0ms	^
DIAL:	ON3 10000ms	OFF3 0ms	^
PULSE BREAK:	MIN 10ms	MAX 90ms	^
PULSE MAKE:	MIN 10ms	MAX 90ms	^

PULSE BREAK MIN

Definition

Sets the minimum pulse break detection time in 1 ms steps.

Value Range

10 to 90 ms

PULSE BREAK MAX

Definition

Sets the maximum pulse break detection time in 1 ms steps.

Value Range

10 to 90 ms

PULSE MAKE MIN

Definition

Sets the minimum pulse make detection time in 1 ms steps.

Value Range

10 to 90 ms

PULSE BREAK MAX

Definition

Sets the maximum pulse make detection time in 1 ms steps.

Value Range

10 to 90 ms

2.9.2. Performing Readback of Dialed Telephone Numbers

Dialed telephone number (DTMF) can also be read back from the TAS 100 Series. The user can review the telephone number last dialed by station A or station B. The station selection parameter is located in the MEASURE menu as shown below. The number "received" by the TAS 100 Series from the station selected is also shown on the same menu line.

MEASURE			
LEVEL =	----dBm	SOURCE	<i>a rcv 2w</i>
STA = a	RCVED #=	-----	

STA

Definition

Sets the station to review the last number received by the emulator.

Value Range

a, b (i.e. station A, or station B)

RCVED

Definition

This field displays the last number received by the TAS 100 SERIES from the station selected.

Value Range

N/A

3.0. REFERENCE

3.1. Overview

This chapter of the manual provides reference information that describes the features that are provided by the TAS 100 Series Telephone Network Emulator. This information is grouped into the following four sections:

Interfaces and Status Indicators

This includes all connectors, indicators, input/output jacks, and status indicators on the front and rear panels of the TAS 100 Series.

Transmission Channel Emulation

This includes all of the impairments generated by the TAS 100 Series. These impairments are divided into analog impairments, digital impairments, and echo. The transmission channel also contains both the input and output level control functions.

Measure/Monitoring

This includes the level measurement, audio output, and scope jack outputs.

Central Office Emulation

This includes all of the simulation required to emulate both switched and private line telephone networks. The TAS 100 Series supports full programmability of exchange configuration features, loop signalling, call progress tones, and dialing analysis.

Some of the sections or items in this chapter apply only to certain model(s) of the TAS 100 family. The notation [*model*, ...] indicates that the section or item only applies to the model(s) listed inside the brackets. Otherwise, the section applies to all TAS 100 family models.

3.2. Interfaces and Status Indicators

The front panel contains status LEDs and RJ-45 modular jacks for access to the network. The rear panel contains the power entry module, fan, remote control interfaces (IEEE-488 and RS-232), terminal strips, a signal monitor jack and a loop simulation interface.

3.2.1. Front Panel LEDs and Interfaces

On the left hand side of the front of the TAS 100 Series are status LEDs and the station A and B modular jack receptacles. The LEDs are used to indicate the network mode and station interface status.

Network Mode Status LEDs

The network may be programmed to operate in one of three modes. The "MODE" LED which corresponds to the current state will be lit. The meaning of the network mode LEDs are as follows:

PRIVATE 4W - Indicates that the telephone network interface emulation is configured for 4-wire private line mode.

PRIVATE 2W - Indicates that the telephone network interface emulation is configured for 2-wire private line mode.

SWITCHED 2W - Indicates that the telephone network emulation is configured for 2-wire switched or 2-wire auto-switched mode.

Station Interface Status LEDs

The status LEDs are used to indicate the status of the station interface when the mode is 2-wire switched or 2-wire auto-switched. The status indicates the state of the signaling at both stations A and B. The status of the station interface is defined by the following:

OFF HOOK: indicates that station A and/or B is off hook and that loop current is flowing.

DIAL TONE: indicates that station A and/or B is receiving dial tone.

RING BACK: indicates that station A or B is receiving a ring back tone.

RINGING: indicates that station A or B is receiving ringing voltage.

CONNECTED: indicates that the call set-up sequence has been successfully completed and that stations A and B are connected.

BUSY: indicates that an unsuccessful attempt was made at station A and/or B to ring the opposite station. This can happen when the dialed station is off hook, or because the number dialed at one station is different from the other station's telephone number.

Note that at any given time one station may have more than one LED lit. For example once one of the stations (telephone or modem) goes off hook both the "OFF HOOK" and "DIAL TONE" LEDs will both be lit for that station.

Station A and B Modular Jacks

Station A and station B modular telephone jacks are RJ-45 type receptacles, they are located in the lower left-hand corner of the front panel. These station set interfaces conform to all mechanical/functional characteristics specified in the EIA TR30.3 Telecommunications Systems Bulletin No. 18. The pin configurations for 2-wire and 4-wire station set interfaces are provided in the technical specification section of this manual.

3.2.2. Rear Panel Terminal Strips, Jacks and Ports

The rear panel of the TAS 100 Series contains the AC power entry module, a fan, 4 terminal strips, a monitor BNC connector, RS-232C and IEEE-488 remote control interfaces, and four RJ-45 type receptacles along with two rocker switches. The detailed functionality of each of these is explained below.

Station A and B Modular Jacks

Station A and B terminal strips are located to the right of the fan and AC entry module. These terminal strips provide signal access to the TAS 100 Series and are directly connected to the front panel 8 position modular telephone jacks. The terminal configurations for 2-wire or 4-wire station set interfaces are provided in the technical specification section of this manual.

Path Breakout Terminal Strip

The EXTERNAL A→B and B→A channel terminal strips are located to the right of the fan and AC entry module just below the Station B terminal strip. The signals from the 4 wire channel (A→B or B→A direction) are available on this terminal strip when the TAS 100 Series is operating in 2 wire mode. When the feature is enabled, the designated signal path through the TAS 100 Series is completely broken to allow the insertion of external impairments to the signal. The output of the TAS 100 Series transmission channels is provided on the pins

labeled "T1" and "R1", and the input signal should be provided back into the TAS 100 Series on the pins labeled "T2" and "R2". The nominal signal level at the output pins will be the output level currently set for the associated channel. The level of the input signal returned to the TAS 100 Series will determine the 2 wire output level at the station A jack for the External B→A Channel and the station B jack for the External A→B Channel.

Balance Network Terminal Strip

In 2-wire configurations this terminal strip allows the user to replace the internally supplied 604 ohm impedance with an external user supplied balance impedance. The external impedance for the hybrid at Station A must be connected between the terminals labeled "A1" and "A2" on the "Balance Networks" terminal block. Likewise, the external impedance for the hybrid at Station B must be connected between the terminals labeled "B1" and "B2" on the "Balance Networks" terminal block. See section 3.5.4.1 for more information on the subject of hybrid balance.

Loop Simulation Interface Jacks and Controls

The A1 EO and A1 NI interface jacks at the upper right side provide the means to insert an external loop emulator into the transmission path of the AC signal at the station A side of the TAS 100 Series. The End Office (EO) end of the loop should be connected to pin 5 (tip) and 4 (ring) of the 8 position A1 EO connector. The Network Interface (NI) end of the loop should be connected to pin 5 (tip) and 4 (ring) of the 8 position A1 NI connector. Use of the A1 EO and A1 NI connectors allows the TAS 100 SERIES to supply loop current and ringing directly to the device at station A without being affected by the characteristics of the loop.

The B1 EO and B1 NI connectors located next to the loop simulation jacks for station A allow an external loop emulator to be inserted into the transmission path of the AC signal at the station B side of the TAS 100 SERIES. The End Office (EO) end of the loop should be connected to pin 5 (tip) and 4 (ring) of the 8 position B1 EO connector. The Network Interface (NI) end of the loop should be connected to pin 5 (tip) and 4 (ring) of the 8 position B1 NI connector. The B1 EO and B1 NI connectors allow the TAS 100 Series to supply loop current and ringing directly to the device at station B without being affected by the characteristics of the loop.

The LOOP A IN/OUT SWITCH located at the upper right side of the rear panel controls the insertion of an external 2-wire loop at the station A interface. Setting the rocker switch to the IN position creates an open circuit allowing the loop that is connected between the rear panel A1 EO and A1 NI connectors to be inserted into the transmission path (between the 2 wire port of the 2 to 4 wire hybrid and the station interface connectors). The OUT position removes the loop.

The LOOP B IN/OUT SWITCH located to the right side of loop A in/out switch controls the insertion of the 2-wire loop at the station B interface. Setting the rocker switch to the IN position creates an open circuit allowing the loop that is connected between the rear panel B1 EO and B1 NI connectors to be inserted into the transmission path (between the 2 wire port of the 2 to 4 wire hybrid and the station interface connectors). The OUT position removes the loop.

Monitor Port

The MONITOR PORT is provided on the rear panel for monitoring the transmit and receive signals at each station interface. Designated "600 OHM MONITOR" it is located near the center of the rear panel. The TAS 100 SERIES can be directed to provide selected signals at this BNC-type jack for external monitoring. The following signals may be selected:

A→B Channel:

a xmit: transmit level of the equipment connected to station A. This signal is monitored on the four wire side of the hybrid.

b rcv 4w: signal level received at the station B 4-wire point.

b rcv 2w: signal level received at the station B 2-wire point. This signal is monitored on the four wire side of the hybrid.

B→A Channel:

b xmit: transmit level of the equipment connected to station B. The signal is monitored on the four wire side of the hybrid.

a rcv 4w: signal level received at the station A 4-wire point.

a rcv 2w: signal level received at the station A 2-wire point. This signal is monitored on the four wire side of the hybrid.

An audible representation of the selected A → B or B → A signal is available on the internal speaker.

RS-232C Remote Control (DTE) Port

The CONTROL (DTE) port is a 25 pin D-sub connector which supports RS-232C. The control port is wired as a Data Transmission Equipment (DTE). All RS-232C remote control of the TAS 100 SERIES must be done via this port. An RS-232C terminal or a PC (IBM compatible) can control the TAS 100 Series through this port via a null modem cable. Two protocols are supported in RS-232

control mode, ACK/NAK (ACKnowledge/Negative ACKnowledge, and CR/LF (Carriage Return/Line Feed). Both of these protocols are explained in full detail in the REMOTE OPERATION section of this manual.

IEEE-488 Remote Control Port

The CONTROL (IEEE-488) port is a 24 pin IEEE-488 receptacle which supports the IEEE-488 (GPIB) protocol. This port must be connected to an IEEE-488 controller to control the TAS 100 Series via IEEE-488. This connection may be either direct or via a multi-point bus which contains other IEEE-488 controlled equipment.

The IEEE-488 controller may be a generic PC with an embedded IEEE-488 control card installed, a IEEE-488 computer, an RS-232 to IEEE-488 converter, or some other IEEE-488 controller. For an installation which includes a TAS 1022HS Gemini and TASKIT software the 1022HS serves as the IEEE-488 controller.

AC Power Receptacle

The AC power receptacle is located on the upper left corner of the rear panel. This receptacle also contains the fuse for the unit. The TAS 100 Series is factory-set for a customer's local power. If it becomes necessary to change that setting, the proper procedure for performing the operation is described below:

1. Remove the power cord and move the plastic slide to the left to reveal the fuse and power selector board (present setting of 100 or 240 should be visible).
2. Pull out the power selector board and then reinsert it for the desired setting (That setting should be facing up and readable after insertion).

3.3. Transmission Channel (Trunk) Simulation

3.3.1. Overview

A high level block diagram of the transmission channel simulation provided by the TAS 100 Series is shown in Figure 3-1. The transmission channel consists of an input level control, an impairments generator (including echo), and an output level control. A single transmission channel processes signals in only one direction at a time.

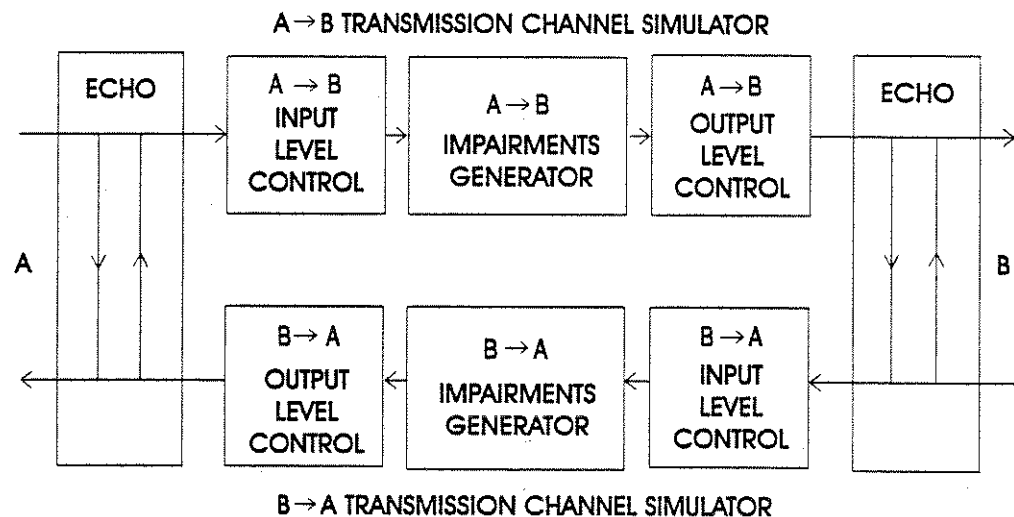

Figure 3-1. Transmission Channel Simulator Block Diagram

The impairment generator is capable of simulating a wide variety of voiceband impairments. These impairments are divided into analog, digital, and echo categories. Analog impairments are those which affect the signal during transmission on analog facilities such as noise and frequency shift. Digital impairments are those which are experienced due to transmission on digital facilities. The digital impairments provided by the TAS 100 Series consists of PCM coding and robbed bit signaling distortion.

The transmission impairments are encountered in the following sequence as a signal transverse each channel from input to output.

1. Satellite Delay [151, 152, 181, 182]
2. Gain Distortion [151, 152, 181, 182]
3. Delay Distortion [151, 152, 181, 182]
4. Intermodulation Distortion [181, 182]
5. Phase Jitter [181, 182]
6. Phase Hits [181, 182]

7. Frequency Shift [181, 182]
8. Gain Hits [181, 182]
9. PCM [151, 152, 181]
10. Impulse Noise [181, 182]
11. Output Attenuation
12. White Noise [151, 152, 181, 182]
13. PCM [182]*

3.3.2. Channel Configuration

The Channel Bypass and Simulation Direction features of the TAS 100 Series add convenience to defining the desired channel simulation configuration.

Channel Bypass

The bypass feature allows all impairments to be easily disabled in either or both transmission channels. The bypass function is active when the LED beside the button is lit. Activating bypass disables all the impairments in the associated channel except for echo. The A→B Channel Bypass causes the signal at the “A Transmit” port to be connected to the “B Receive 4-Wire” port if the TAS 100 Series is in 4-wire mode and to the “B Receive 2-Wire” port in 2-wire mode. The B→A Channel Bypass causes the signal at the “A Transmit” port to be connected to the “B Receive 4-Wire” port if the TAS 100 Series is in 4-wire mode and to the “B Receive 2-Wire” port in 2-wire mode.

Simulation Direction [151, 181]

Models 151 and 181 of the 100 Series are equipped with a single impairment generator. This impairment generator is designated "impairment generator 1" and by default is placed in the A→B transmission channel. The 151 and 181 allow the user to reposition impairment generator 1 to be in the B→A channel. When the impairment generator is placed in the "B to A" direction the currently defined input and output level controls for each channel are not affected. In other words the input and output levels parameters that were defined for the A→B remain unchanged as well as the B→A input and output levels, but the remaining characteristics of the A→B channel are transferred to the B→A channel. Figure 3-2 displays the simulation direction "A to B" configuration, and Figure 3-3 displays the "B to A" configuration.

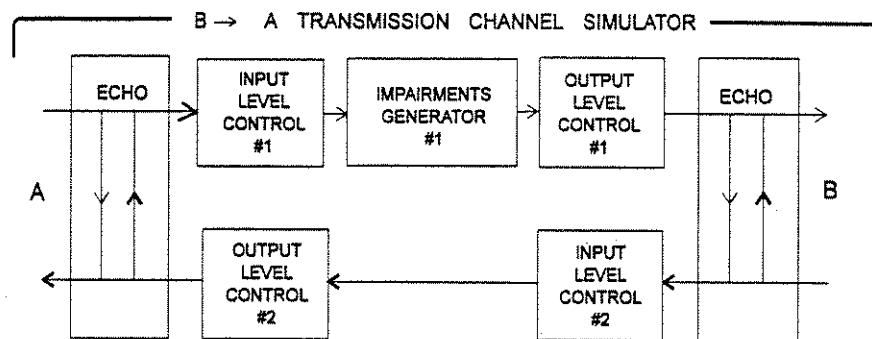

Figure 3-2. TAS 151 or 181 A to B Simulation Direction Configuration

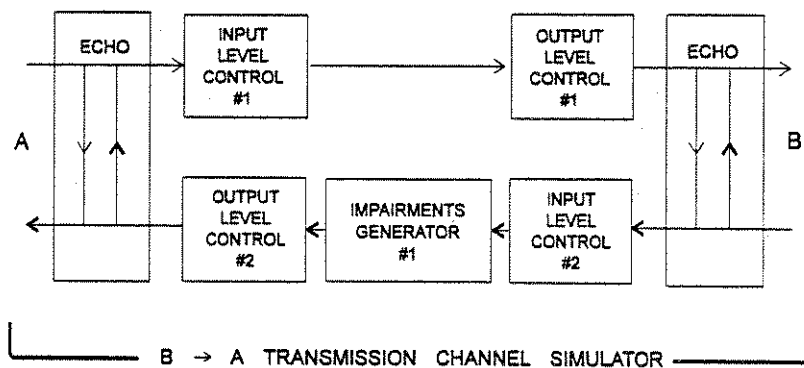

Figure 3-3. TAS 151 or 181 B to A Simulation Direction Configuration

3.3.3. Input Level Control

Each impairment channel of the TAS 100 Series generates a number of impairments by processing the incoming signal. The levels and other parameters of these impairments can depend on the level of the incoming signal. In order to optimize the accuracy of the impairments the incoming signal level should be normalized. For the TAS 100 Series this normalized level is 0.0 dBm. The primary function of the input level control sections is to adjust the level of the signal being applied to the TAS 100 Series to achieve this 0.0 dBm level for the impairment generator. This adjustment may be either gain (increase of the input signal), or attenuation (decrease of input signal level). The TAS 100 Series provides two methods for control of the input level; direct setting of the "nominal input level", and the "input AGC". Setting the nominal input level results in a single step adjustment while the input AGC results in a ramped adjustment from the current setting to the new setting.

Nominal Input Level

To properly set the input level control using the nominal input level the value of the nominal input level parameter must be set to the same level as the signal being applied to the TAS 100 Series transmission channel. As an example, for a modem with a transmit level of -10.0 dBm connected to the Station A port, the A→B nominal input level of the TAS 100 Series should also be set to -10.0 dBm. This setting will result in a 10.0 dB gain in the input level control block thereby providing a 0.0 dBm signal to the A to B impairment channel.

The nominal input level operates in single step mode. In this mode the new value of input level control is immediately written into the input attenuator. This results in a single step (up or down) in the signal level throughout the channel. If the level of the step is large, modems connected through the channel may experience a gain hit large enough to cause retraining or a disconnect. The nominal input level can be set in 0.1 dBm steps from a level of -23.0 to +7.0 dBm.

Input AGC

The input AGC (Automatic Gain Control) is one of the most misunderstood features of the TAS 100 Series, however it is quite straightforward. Simply put, an input AGC is a method of performing an automatic input level adjustment. When the AGC command (for either the A→B or B→A transmission channel) is issued to the TAS 100 Series, a level measurement is performed on the input signal applied to the input level control circuit for that channel. The nominal input level of that channel is then set (by ramping the attenuation of the input control block either up or down to the new desired level) based on the measured level to provide a normalized signal level (0.0 dBm) into the impairment generator.

The input AGC does not continuously track the input signal over time. It is a one time measure and set sequence. If the input signal changes after the AGC has been performed, the resulting level into the impairments generator will not be 0.0 dBm. When the AGC is performed the user should be sure that there is a valid signal applied to the input level control block, if not, the AGC function will fail and an error message will be generated.

Prior to performing the input AGC white noise in the impairment generator is turned off (if it is on). This ensures that the measured level is adjusted without any power contribution of the noise. This technique will result in a more accurate Signal to Noise ratio (S/N).

When an AGC is performed the nominal input level set by the user is overwritten. Once a new nominal input level is set by the user the AGC will be lost.

The input AGC supports an input signal in the range of -23.0 to +7.0 dBm.

Input AGC should be used in applications where the input signal level is unknown.

3.3.4. Output Level Control

The setting of the output level determines the level of the signal transmitted out of the TAS 100 Series for that direction (A to B or B to A). The difference between the input level and the output level determine the loss of the transmission channel. As an example, to establish a channel with 20.0 dB of loss using a modem which transmits at -10.0 dBm, the nominal input level should be set to -10.0 dBm, and the output level should be set to -30.0 dBm

There are two methods for setting the output level, directly via the output level command, and the output (or modem power) AGC.

Output Level

The output level is controlled by setting the amount of attenuation in the output level control block. This attenuation is set with the assumption that the signal level into the output level control module of the transmission channel simulator is 0.0 dBm . This output level is calibrated for a 1004 Hz signal. In the event that the signal through the TAS 100 Series is a complex signal with energy at frequencies other than 1004 Hz the effects of gain distortion may cause the resulting output power level to be different from the programmed output level. In order to set an RMS output level for a complex signal the output AGC must be used.

The output level operates in single step mode. In single step mode the new value of output level control is immediately written into the output attenuator. This results in a single step (up or down) in the signal level at the output of the channel. If the level of the step is large, modems connected through the channel may experience a gain hit large enough to cause retraining or a disconnect.

Output (Modem Power) AGC

The output AGC is very similar to the input AGC. When an output AGC is selected on a transmission channel, a true RMS measurement on the signal out of the impairment generator (into the output level control block) is performed, and the output level control attenuator is adjusted accordingly to provide the signal level set by the last output level command. Because the measurement in the TAS 100 Series is an RMS measurement, the resulting output level will be the RMS level as set by the output level command. In order to ensure the end-to-end levels through the transmission channel when an output AGC is performed, an input AGC is also performed. The input AGC precedes the output AGC.

As an example of the effect that an output AGC can have on a signal consider the case when a 2400 Hz signal is applied to the input of the transmission channel at a level of -15.5 dBm. Assume that the last nominal input level was set for -15.0 dBm, and the last output level set was for -20.0 dBm, and also assume that in the channel is a gain shape which attenuates a 2400 Hz signal by 10.0 dB. Without performing an output AGC, signal levels are as follows:

- Input level control input = -15.5 dBm
- Input level adjust = +15.0 dB
- Input level control output = -0.5 dBm
(also the input level into the impairment generator)
- Impairment generator output = -10.5 dBm
(also the input level into the output level control)
- Output level control output = -30.5 dBm
- Output level adjust = -20.0 dB

Due to the 10.0 dBm loss through the impairment channel, the output level will be reduced by the same amount. Once an output AGC (includes an input AGC) has been performed the following levels will exist:

- Input level control input = -15.5 dBm
- Input level adjust = +15.5 dB
- Input level control output = 0.0 dBm
(also impairment generator input)

- Impairment generator output = -10.0 dBm (also output level control input)
- Output level control output = -20.0 dBm
- Output level adjust = -10.0 dB

After performing the output AGC, the entire channel is properly aligned in terms of the levels at each interface. Both the setting of the input level and the output level controls are modified by the AGC. This overrides both the nominal input level, and the output level for the channel. If the user now sets any nominal input level, both the input and output AGCs are lost. The setting of the input level control is determined by the nominal input level value, and the setting of the output level control reverts back to the last output level programmed by the user. If the user sets any output level value, only the output AGC is lost. The setting of the output level control is determined by the output level value.

Prior to performing the output AGC white noise in the impairment generator is turned off (if it is on). This ensures that the measured level is adjusted without any power contribution of the noise. This technique will result in a more accurate Signal to Noise ratio (S/N).

3.3.5. Analog Impairment Generators

Most of the TAS 100 Series impairments are analog impairments and will be described in terms of their affect on the analog input signal. However, these impairments are generated using Digital Signalling Processing (DSP) techniques. Each impairment will be described along with all of its parameters.

Frequency Shift [181, 182]

The frequency shift impairment modulates the frequency of the input signal by an amount equal to the frequency parameter. This modulation is a fixed (time invariant) amount which is applied equally to all frequency components of the input signal.

The following are the user programmable parameters for frequency shift:

Frequency - The frequency parameter sets the amount of frequency shift to be applied to the signal. The frequency may be programmed in steps of 0.25 Hz.

Status - Turn frequency shift on or off.

Gain/Delay Distortion [151, 152, 181, 182]

The Gain and Delay Distortion impairments independently affect the gain or delay versus frequency characteristics of the input signal. The TAS 100 Series allows gain distortion and delay distortion to be programmed as a single combined impairment or as two independent impairments.

The following are the user programmable parameters for gain and delay distortion:

Line - Simultaneously selects both the gain versus frequency and delay versus frequency characteristic of the TAS 100 Series as a combined impairment.

Custom Gain - Selects the gain versus frequency characteristics independent of the delay versus frequency characteristic when the Line parameter is set to "Custom".

Custom Delay - Selects the delay versus frequency characteristics independent of the gain versus frequency characteristic when Line parameter is set to "Custom".

Impulse Noise [181, 182]

The TAS 100 Series generates an IEEE standard impulse as specified in IEEE 743-1984. The IEEE standard impulse noise is shown in Figure 3-4. The spectral energy of this signal is primarily concentrated in the frequency range below 3500 Hz.

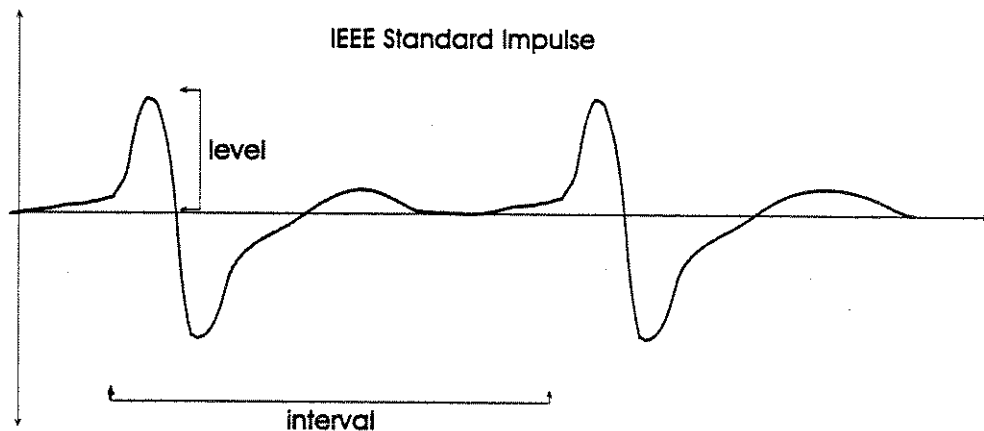

Figure 3-4. IEEE Standard Impulse

The following are the user programmable parameters for impulse noise:

Level - The level of the IEEE impulse noise is defined as the peak level or threshold reached by the impulse as measured by a Transmission Impairment Measurement Set (TIMS) after the impulse has been passed through the C-Notch

filter of the TMS. The peak level is programmed in units of dB relative to the normalized signal level (see section 3.3.3). The TAS 100 Series also reports the absolute level of the impulse in units of dBm (dBm = dBm + 90).

Interval - The interval is defined as the time between successive impulse events.

Status - Turn impulse noise on or off.

Intermodulation Distortion (IMD) [181, 182]

The IMD impairment consists of second order and third order components. The second and third order distortions are independent. Second order distortion is generated by squaring the input signal and adding this signal back into the original signal. Third order distortion is generated by cubing the input signal and adding this signal back into the original signal. The measured levels of IMD will only be correct when the measurement is performed using the "four tone" technique as defined by IEEE Standard 743-1984. The level of the four tone test signal must be properly normalized by the input level circuit of the TAS 100 Series as described in section 3.3.3.

IMD has two simulation techniques available, the choices are "Proprietary" or "Standard (TAS 1010)". The "Standard (TAS 1010)" selection emulates the implementation provided in the TAS 1010 family of Channel Simulators. For a complex transmission signal such as a modem signal, the Proprietary selection typically results in a higher level of IMD (and thus a reduced signal to total distortion ratio) than the Standard (TAS 1010) selection. However the distortion measured using the standard IEEE 4-tone technique will be the same for both selections.

The TAS 100 Series uses Digital Signal Processing (DSP) techniques to provide all of its transmission impairment simulation including IMD. "Proprietary IMD" as well as the other impairments are generated at the standard telephone network sampling rate of 8 kHz. But the "Standard (TAS 1010)" IMD is generated at a 16 kHz sampling rate. The sampling frequency has significant impact on the characteristics of the two IMD simulation techniques.

A DSP based system can only support signals that are bandlimited to have a frequency content that is less than half the sampling rate. Signals with frequency components above this limit will cause signal distortion because these signal components are translated (alias) into frequencies that are below the limit (one half the sampling rate).

The frequency content of a voiceband signal resides primarily within the band from 200 Hz to 3500 Hz. Signal components that alias from higher frequencies

into this band will cause signal distortion. This phenomenon is the cause of the higher level of total distortion that is generated by the "Proprietary IMD".

Signal components that are at higher frequencies than the original signal are generated when the square (2nd order IMD) and cube (3rd order IMD) operations are performed to simulate the IMD impairment. Forming the square creates a signal with a frequency content that is twice the frequency of the original signal. While the formulation of the signal cube creates a frequency content that is triple that of the original signal. For example, the cube of a 3 kHz signal creates a signal at 9 kHz. A 9 kHz signal can not be supported by a DSP system that has either an 8 kHz or a 16 kHz sampling rate, and as a result the signal will alias to 1 kHz in the 8 kHz DSP system and to 7 kHz in the 16 kHz system. The 8 kHz DSP system will experience additional signal distortion because the 1 kHz alias is in the primary frequency band (200 Hz to 3500 Hz). Conversely, the 16 kHz DSP system will not experience an increase in signal distortion because the 7 kHz alias is not in the primary frequency band and because frequencies above 4 kHz are removed by a post processing filter (reconstruction filter).

The "Proprietary IMD" and the "Standard (TAS 1010)" IMD techniques provided by the TAS 100 Series usually have an equivalent affect on modem transmission performance at speeds of 9.6 kbps and below, and at low IMD levels (40 dB to 60 dB below signal level). The most significant performance difference between the two IMD techniques will be experienced by high speed (greater than or equal to 14.4 kbps) modems at high levels (20 dB to 40 dB below signal level) of IMD. The following are the user programmable parameters for IMD:

Level - The level for both 2nd and 3rd order distortion is in units of dB below the signal.

Mode - The mode parameter controls the phase of the distortion relative to the phase of the input signal. When the mode is expansive the distortion signals are added in phase. When the mode is compressive, the distortion signals are added out of phase. This mode has the most effect on 3rd order IMD, because the cube of the input signal results in a component at the fundamental. The net result is that expansive 3rd order IMD will result in an increase of the fundamental signal while compressive 3rd order IMD will decrease the fundamental.

Option - Selects either the "Proprietary IMD" or the "Standard (TAS 1010)" IMD techniques.

Status - Turn IMD on or off.

Phase Jitter [181, 182]

The phase jitter impairment is generated by modulating the phase of the input signal with a sine wave. The jitter will equally affect all frequency components of the input signal.

The following are the user programmable parameters for phase jitter:

Jitter Level - The level of jitter in degrees peak to peak (relative to the un-jittered signal).

Frequency - The frequency of the modulation sine wave form.

Status - Turn phase jitter on or off.

White Noise (Random Noise) [151, 152, 181, 182]

White (or random) noise is an additive impairment and is defined as a signal which has an equal amount of energy at all frequencies within the specified bandwidth of the noise signal. When viewed on a spectrum analyzer the result would be a level versus frequency spectrum which is flat over the specified band.

Transmission Impairment Measurement Set (TIMS) that is designed to IEEE or CCITT standards uses an input weighting filter to measure noise. This filter weights (shapes) the noise for a particular frequency band of interest before the noise level is measured. See Figure 3-5 for a diagram of noise measurement setup.

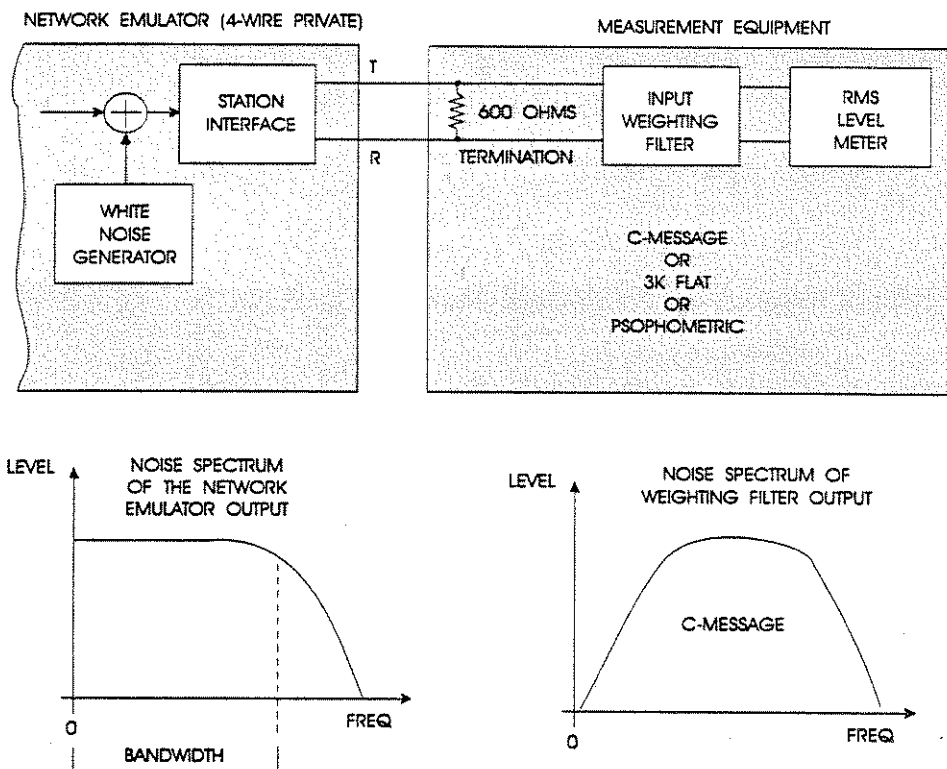

Figure 3-5. Noise Measurement Setup

Level - The level of noise is specified in units of dBm, the conversion to dBm is:

$$\text{level in dBm} = \text{level in dBm} - 90.0.$$

The level of the noise signal added into the signal path is determined by the level parameter and the setting of the correction factor explained below.

Level Weighting Correction - The TAS 100 Series level weighting correction is an adjustment to the level of the noise spectrum in order to provide correlation between the level of noise generated by the TAS 100 Series and the level that would be measured by external measurement equipment. When a correction value is selected, the level of all frequency components of the noise signal are adjusted (either increased or decreased).

To further explain the concept of the level correction factor consider the following example:

TAS 100 Series Setup:

Network configuration: 4-wire private

Noise level: 60.0 dBm

Level correction: C-Message

All other impairments: off

Measurement Equipment Setup:

Input termination: 600 ohm

Weighting Filter: C-Message

This example is illustrated in Figure 3-5. In this situation the measurement equipment would report a noise level of 60.0 dBm (ignoring tolerances), which corresponds to the level programmed in the TAS 100 Series. If the weighting filter of the measurement equipment is changed to 3K Flat while the TAS 100 Series weighting correction remains set to C-Message, the equipment would then report a noise level of 61.7 dBm (ignoring tolerances). The increase in the measured noise level is due to the fact that the 3K Flat weighting filter has a larger passband than the C-Message filter. The larger passband allows more noise power to reach the RMS level meter of the measuring set, resulting in a 1.7 dB increase in the reported noise level. If the TAS 100 Series weighting correction is then changed to 3K Flat, the noise generator will reduce (correct) its level by 1.7 dB. The measurement equipment will once again measure 60.0 dBm (ignoring tolerances).

Status - Turn noise on or off.

Gain Hits [181, 182]

Gain hits are temporary changes in the level of the input signal. In the TAS 181 or 182 gain hits are generated by modulating the level of the input signal with a trapezoidal waveform. The waveform defines the rise time of the gain hit, the duration, and the interval between hits. The trapezoidal waveform returns to its beginning state. The trapezoid may be positive (signal level increases during hit), or negative (signal level decreases during hit). See Figure 3-6 for the definition of the gain hit waveform.

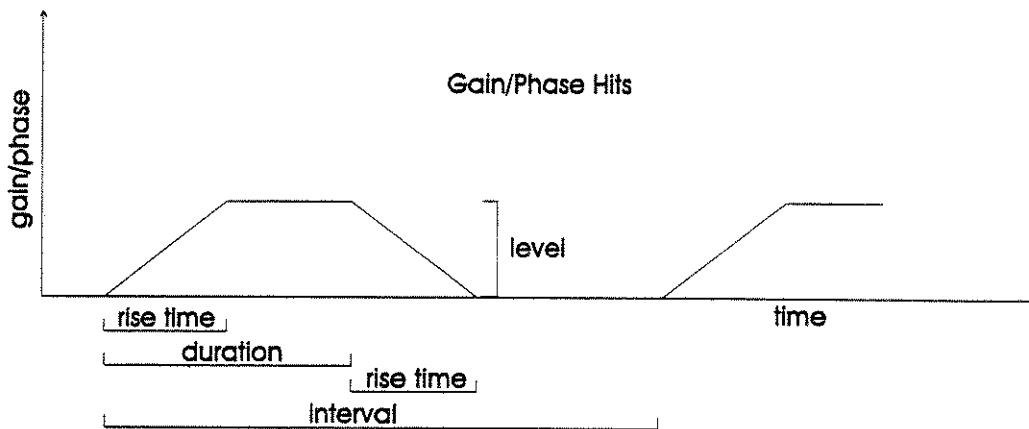

Figure 3-6. Gain Hit/Phase Hit Modulation Waveform

Level - The measure in dB (decibels) of the magnitude of the gain hit. The gain hit level may be positive (increased level) or negative (decreased level). The level change caused by the gain hit is relative to the signal level at the input of the gain hit generator.

Rise Time - The time of transition from no gain hit to the programmed level of the hit. This time is identical to the rise time of the trapezoidal modulation waveform as measured from the minimum level of the signal to the maximum. The waveform is completely symmetrical so that the fall time is the same as the rise time.

Duration - The time interval measured from the beginning of the gain hit to the start of the removal of the hit. In terms of the modulation waveform this is the time from the start of the ramp up to the start of the ramp down.

Interval - The time between the start of one gain hit to the start of the next. In terms of the modulation waveform this is the time from the start of the ramp up of one occurrence to the start of the ramp up for the next. The user must be careful not to program the interval to be any less than the duration plus twice the rise time.

Status - Turn on or off gain hits

Phase Hits [181, 182]

Phase hits are temporary changes in the phase of the input signal. In the TAS 181 and 182 phase hits are generated by modulating the phase of the input signal with a trapezoidal modulation waveform. The waveform defines the rise time of the phase hit, the duration, and the interval between hits. See Figure 3.3.5.7-1 for the definition of the phase hit modulation waveform.

Level - The measure in degrees of the magnitude of the phase hit.

Rise Time - The time of transition from no phase shift to the programmed level of the phase hit. This time is identical to the rise time of the trapezoidal modulation waveform as measured from the minimum level of the signal to the maximum. The waveform is completely symmetrical so that the fall time is the same as the rise time.

Duration - The time interval measured from the beginning of the phase hit to the start of the removal of the hit. In terms of the modulation waveform this is the time from the start of the ramp up to the start of the ramp down.

Interval - The time between the start of one phase hit to the start of the next. In terms of the modulation waveform this is the time from the start of the ramp up of one occurrence to the start of the ramp up for the next. The user must be careful not to program the interval to be any less than the duration plus twice the rise time.

Status - Turn on or off phase hits.

Amplitude Jitter [182]

The amplitude jitter impairment is generated by modulating the amplitude of the input signal with a sine wave.

The following are the user programmable parameters for amplitude jitter:

Jitter Level - The measure of peak-to-peak amplitude jitter in percent (%) of input signal level.

Frequency - The frequency of the modulation sine waveform.

Status - Turn amplitude jitter on or off.

Single Frequency Interference [182]

Single frequency interference (SFI) is an additive impairment which generates a single frequency tone which is added to the output signal.

The following are the user programmable parameters for SFI:

Jitter Level - The SFI level is presented in terms of the level below the level of the output signal. for example if the output level of the Transmission channel is -10.0 dBm and the level of SFI is 10.0 dB, the actual level of the SFI signal will be -20.0 dBm.

Frequency - The frequency of the SFI signal added to the transmission path.

Status - Turn SFI on or off.

3.3.6. Digital Impairments (PCM) [151, 152, 181, 182]

The TAS 100 Series PCM feature provides the means to test modem performance over various simulated digital transmission systems. With this feature it is possible to perform the following functions:

1. Simulate one digitally coded transmission link as mu-law or A-law 64 Kbps PCM for models 151, 152, and 181. Simulate from one to three links digitally coded transmission links as mu-law or A-law 64 Kbps PCM for model 182.
2. Insert PCM robbed-bit signaling.
3. Select PCM position as first or last impairment generated (Model 182 only).

On the 182 model there is an additional PCM module which simulates up to 3 links of PCM. Table 3-1 lists typical signal to noise (S/N) ratios for 1 to 3 links of PCM. The input signal is a 1004 Hz tone and the noise is measured at 5 output levels from 0.0 dBm to -40.0 dBm for mu-law coding with the PCM module positioned as the last impairment and all other transmission impairments disabled. The S/N performance with the PCM module positioned as the first impairment is represented by the data measured at an output signal (1004 Hz tone) of 0.0 dBm.

1004 Hz LEVEL (DBM)	1 LINK S/N (DB)	2 LINKS S/N (DB)	3 LINKS S/N (DB)
0.0	41	38	37
-10.0	41	38	36
-20.0	39	35	34
-30.0	36	33	32
-40.0	29	27	25

Table 3-1. Typical S/N Performance for 64 kbps (PCM) Links

PCM Coding

A PCM link is defined as containing the following elements:

- Anti-Aliasing Filter
- Mu-law or A-law Analog to Digital (A/D) Converter
- Mu-law or A-law Digital to Analog (D/A) Converter
- Reconstruction Filter

The PCM Coding feature provided by the 100 Series simulates the transmission characteristics of one PCM link including the gain/delay distortion caused by a link's anti-aliasing and reconstruction filters as well as the quantization distortion caused by a link's A/D and D/A converter. The 100 Series allows the user to

select the algorithm used in analog to PCM converter. These algorithms optimize the dynamic range of the analog data sample. The choices are mu-law, and A-law.

Both mu-law and A-law compress approximately 13 bits of dynamic range into 8 bits. Mu-law is the companding characteristic adopted by the U.S. and Japan, while A-law is the companding characteristic recommended by CCITT.

Robbed Bit Signaling

This feature provides simulation of robbed bit signaling in the PCM link. The least significant bit of every sixth frame is robbed and replaced with an alternating "0" and "1" bit pattern. (A frame refers to a T1 frame of 125 microseconds duration.). For Model 182, this feature can be activated on the first link only.

PCM Position

The PCM simulation provided by the 100 Series is located in the output portion of each transmission channel that contains an impairment generator. This configuration simulates a transmission channel that consists of a cascade arrangement of an analog transmission facility that is followed by a digital transmission facility. In this position the nominal signal level that is input into the PCM module is 0 dBm. On model 182, PCM can be either the first or last impairment generated.

PCM and the other impairments are encountered in the following sequence as a signal traverses the channel from input to output.

1. Satellite Delay [151, 152, 181, 182]
2. Gain Distortion [151, 152, 181, 182]
3. Delay Distortion [151, 152, 181, 182]
4. Intermodulation Distortion [181, 182]
5. Phase Jitter [181, 182]
6. Phase Hits [181, 182]
7. Frequency Shift [181, 182]
8. Amplitude Jitter [182]
9. Gain Hits [181, 182]
10. PCM [151, 152, 181, 182]
11. Single Frequency Interference [182]
12. Impulse Noise [181, 182]
13. Output Attenuation
14. White Noise [151, 152, 181, 182]
15. PCM [182]

3.3.7. Echo/Satellite Delay

The TAS 100 Series provides extensive echo simulation capability. This includes near talker echo, far talker echo, and listener echo.

An echo is an unwanted replica of the transmission signal that is caused by a signal reflection at one or more impedance discontinuities, and is delayed in time relative to the original signal.

The terms “near talker echo”, “far talker echo”, and “listener echo” that are used to describe the most common types of echo, originate from voice communication applications. This terminology specifies the relative location from where the echo originated, as well as the identity of the signal that comprises the echo. The location of the echo and its composition is relative to the party that hears (receives) the echo.

“Talker Echo” is a replica of the signal that a party speaks (talks) that is heard at the end of the network where the speaker is located. The speaker in a data communications application is the modem’s transmitter and the echo is heard by the modem’s receiver.

“Listener Echo” is a replica of the signal which a party hears (listens to) that is heard more than once by the listener. The listener in a data communications application is a modem’s receiver.

“Near Echo” is a special case of talker echo in which the modem’s transmit signal is reflected at a location near the modem’s receiver, and as a result, has little to no associated time delay.

“Far Echo” is a special case of talker echo in which the modem’s transmit signal is reflected at a location far from the modem’s receiver, and as a result has significant time delay. The TAS 100 Series supports the following echoes:

- Station A Near Talker Echo
- Station A Far Talker Echo
- Station A Listener Echo
- Station B Near Talker Echo
- Station B Far Talker Echo
- Station B Listener Echo

Near Talker Echo

The TAS 100 Series provides near end talker echo simulation for station A and station B. Station A (B) near talker echo is illustrated in Figure 3-7 and is the reflection of the modem A (B) transmit signal that occurs at modem A (B). This reflection is caused by the impedance mismatch between the modem's hybrid balance impedance and the input impedance (Zmag) of the TAS 100 Series station A (B) 2-wire interface.

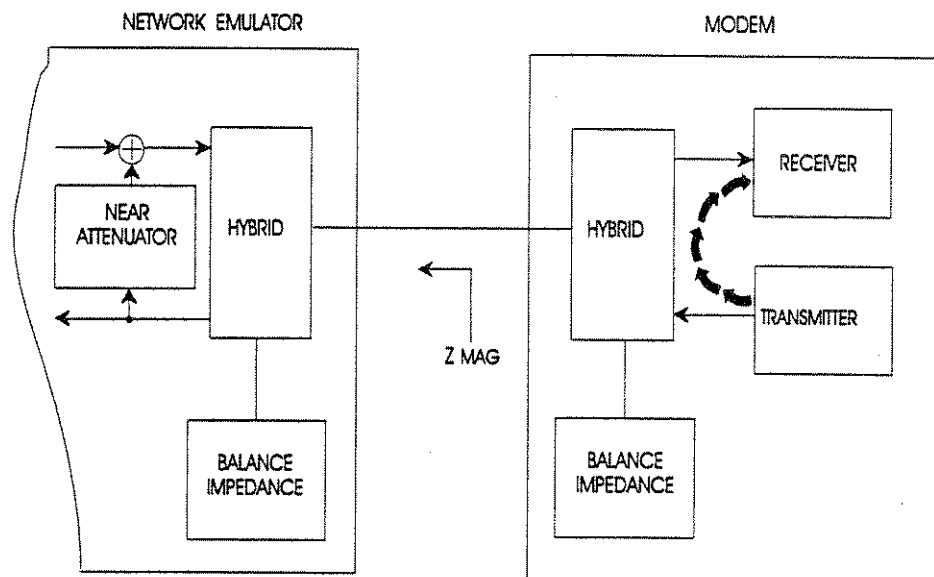

Figure 3-7. Near Talker Echo Without Loop

The simulation is generated with the near A (B) echo attenuator and polarity control circuit. This capability allows the user to program the attenuation and polarity of the signal that is fed back from the transmit port to the receive port of the TAS 100 Series' 2 to 4 wire hybrid. The net result of the signal feedback is that the input impedance of the TAS 100 Series 2-wire interface is modified from its nominal magnitude of 600 ohms. The following table 3.3.7.2-1 indicates the attenuation level and polarity setting for the near end echo parameters that generate a specific nominal magnitude of input impedance. The echo polarity should be set to positive to create impedance values less than 600 ohms, and should be set to negative for values greater than 600 ohms. The attenuation is calculated as follows:

$$\text{Attenuation} = -20 \log (\text{abs}((Z_{\text{mag}} - 600)/(Z_{\text{mag}} + 600)))$$

where:

abs = absolute value

Zmag = desired impedance magnitude

INPUT IMPEDANCE MAGNITUDE (OHMS)	NEAR ECHO ATTENUATION (DB)	NEAR ECHO POLARITY
300	9.5	positive
350	11.6	positive
400	14.0	positive
450	16.9	positive
500	20.8	positive
550	27.2	positive
600	40 or off	positive
650	28.0	negative
700	22.3	negative
750	19.1	negative
800	16.9	negative
850	15.3	negative
900	14.0	negative
950	12.9	negative
1000	12.0	negative
1050	11.3	negative
1100	10.6	negative
1150	10.1	negative
1200	9.5	negative
1250	9.1	negative
1300	8.7	negative
1350	8.3	negative
1400	8.0	negative

Table 3-2. Input Impedance Simulation Summary

Note the following when using table 3-2:

- A negative value of attenuation produces signal gain instead of loss.
- An attenuator setting of 30 dB or more effectively disables the near echo simulation in 2-wire configurations.

The 2-wire line interface of a modem is connected to its transmitter and receiver through a device called a hybrid. A hybrid is a four-port device used to separate signals traveling in both directions along a single pair of wires (2-wire) into individual directions (4-wire), and to recombine those signals traveling on 4-wire circuits for use at the 2-wire interface.

The modem's hybrid has a transmitter and a receiver connected to two of its four ports, the 2-wire network interface to the third port, and the balance network connected to the fourth port. If the impedance of the balance network is equal to the impedance at the 2-wire port over the frequency range of the signal, then the transmit and receive ports are conjugate ports, that is, these ports are decoupled. The magnitude of decoupling is expressed as trans-hybrid loss. An ideal hybrid would have an infinite trans-hybrid loss.

The level of near talker echo that is experienced by a modem is equal to the modem's transmit level minus its trans-hybrid loss. The trans-hybrid loss is a function of the degree of mismatch between the modem's balance network impedance and the input impedance of the network. The impedance presented to the modem that is created with the near echo attenuator and polarity control circuit of the TAS 100 Series is primarily resistive and is constant with respect to frequency. However, in practice, the input impedance of the actual telephone network is not just resistance, but also includes a reactive component, and is a function of frequency. This is due to the make-up of the loop plant. The loops vary because of cable gauge, length, loading, and termination. These loops present an impedance to the modem that is complex (resistive and reactive) and changes as a function of frequency.

To test modem performance in a laboratory setting, especially the response of a modem to an echo condition, a testing arrangement is required whereby various mismatch conditions representative of those which occur in an actual field setting may be conveniently simulated. The TAS 240 Voiceband Subscriber Loop Emulator (VSLE) may be used with the TAS 100 Series as described in section 1.6.2 to provide this capability. Loop emulation provides an alternative technique for generating near talker echo in which the modem is presented with a complex (resistive and reactive) input impedance that is a function of frequency. This type of impedance is more representative of actual network conditions.

The 2-wire loop functions as a transmission line to connect the modem (unit under test) to the 2-wire port of the Central Office (TAS 100 Series). The transmission

line (loop) is terminated at one end by the input impedance of the TAS 100 Series and at the other end by the input impedance of the modem. The impedance seen by the 2-wire port of the modem's hybrid is Z_{in} as shown in Figure 3-8.

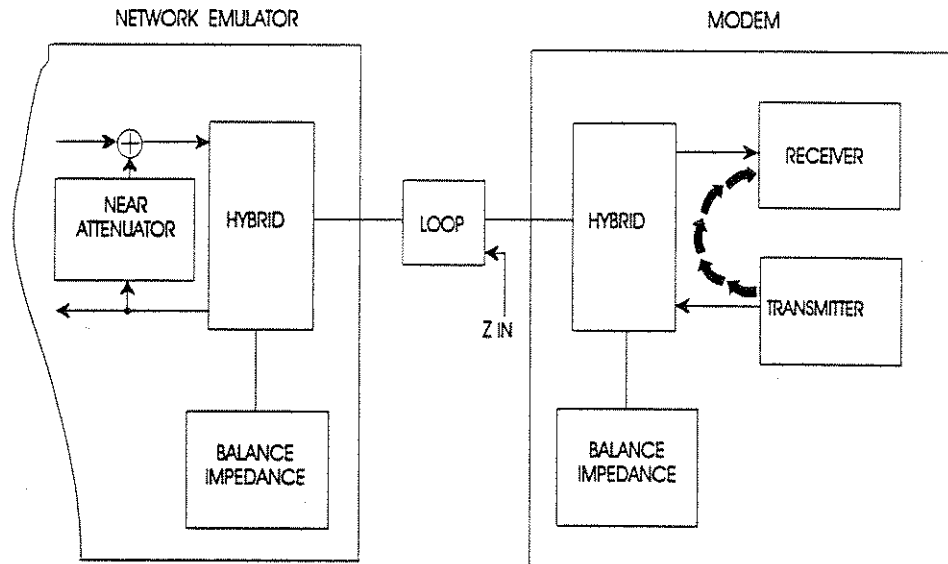

Figure 3-8. Near Talker Echo With Loop

Transmission line theory specifies that if a loop is terminated in an impedance that is not equal to its characteristic impedance, there will be a signal reflection at the point of this termination. In this application, the loop is terminated by the input impedance of the TAS 100 Series. The input impedance magnitude of the TAS 100 Series is approximately 600 ohms (if the near echo attenuator has greater than 30 dB attenuation), which usually does not match the characteristic impedance of the loop. As a result, a reflection will occur at the termination mismatch created by the TAS 100 Series input impedance.

For applications that include the use of 2-wire loops to simulate near talker echo, there are several important facts that are worthy of note:

- The signal reflection that takes place because of the impedance mismatch at the loop termination changes the "effective input impedance" of the loop as seen by the modem's 2-wire interface.
- The level of near talker echo that is experienced by a modem is equal to the modem's transmit level minus its trans-hybrid loss. The trans-hybrid loss is determined by the impedance matching between the modem's hybrid balance impedance and the "effective input impedance" of the loop.
- No near talker echo will be present at the receive side of the modem's hybrid if its hybrid balance impedance is equal to the "effective input impedance" of the loop.

- Near echo occurs at the modem's hybrid and the relatively small time delays associated with the echo is caused by the energy storage characteristics of the "effective input impedance" of the loop and the modem's hybrid balance impedance.

Far Talker Echo/Satellite Delay

The TAS 100 Series provides far end talker echo simulation for station A and station B. Station B (A) far talker echo is illustrated in Figure 3-9 and is the reflection of the modem B (A) transmit signal that occurs at the station A (B) hybrid (far end) of the TAS 100 Series. The magnitude of this reflection is determined by the trans-hybrid loss of the station A (B) hybrid. The station B (A) far echo attenuator magnitude is equal to the trans-hybrid loss of the TAS 100 Series hybrid A (B), if the hybrid is balanced.

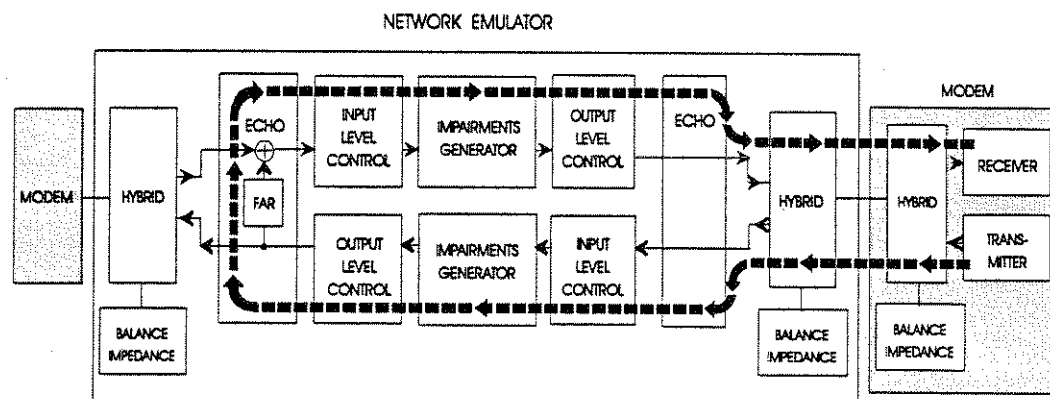

Figure 3-9. Far Talker Echo

The level of the far talker echo that is received at modem B (A) is determined by the loss in the A→B and B→A transmission channel along with the loss of the far echo attenuator B (A). Loss is the difference between the value of input level and output level.

The time delay (propagation delay) of far echo is determined by the transmission time delay in the A→B and B→A directions. Adjustable transmission time delay is available with the TAS 100 Series by utilizing its satellite delay feature. However, note that satellite delay constitutes only part of the total propagation delay that a signal will encounter from station to station of a TAS 100 Series transmission channel. Always adding to the overall propagation delay is the channel residual delay, together with the transmission time delay of IMD [181, 182] and PCM [151, 152, 181, 182] in addition to each selected group delay distortion filter [151, 152, 181, 182]. While Standard IMD adds 1.8 msec when it is on, the Proprietary IMD Option adds 0.0 msec. PCM adds 1.2 on models 151, 152, and 181, and 0.5 msec per link on model 182 when turned on. Each of the group delay characteristic filters add unique transmission time delay as indicated

in the technical specifications section of the manual. The total signal transmission time delay of a TAS 100 Series transmission channel is determined as follows:

- **TAS 150**
Total transmission delay of each channel
 = 0.4 msec (channel residual delay)
- **TAS 181**
Total transmission delay of each impairment generator channel
 = 5.9 msec (channel residual delay)
 + group delay distortion filter transmission delay
 + 1.8 msec; IMD transmission delay (if on, with Standard Option)
 + 1.2 msec; PCM transmission delay (if on)
 + programmed satellite delay time
Total transmission delay of TAS 181 channel without impairment generator
 = 0.4 msec (channel residual delay)

The equation for the impairment generator channel can also be written as follows to determine the magnitude of satellite delay that is required to achieve a specific value of total transmission delay:

$$\begin{aligned}
 &\text{Programmed satellite delay time} \\
 &= \text{desired total channel delay} \\
 &\quad - 5.9 \text{ msec (channel residual delay)} \\
 &\quad - \text{group delay distortion filter transmission delay} \\
 &\quad - 1.8 \text{ msec; IMD transmission delay (if on, with Standard Option)} \\
 &\quad - 1.2 \text{ msec; PCM transmission delay (if on)}
 \end{aligned}$$

For example, if the "EIA A" gain filter along with the "EIA 1" delay filter are selected with IMD and PCM on (enabled), and a total round trip delay of 80.0 msec is desired, then satellite delay is calculated as illustrated below.

TAS 181:

- Required delay for impairment generator channel
 = desired round trip delay - residual delay of channel without impairment generator
 = 79.6 msec
- Programmed satellite delay time for the impairment generator channel
 = 67.8 msec
 = 79.6 msec - 5.9 msec - 2.9 msec - 1.8 msec - 1.2 msec

- **TAS 182**

Total transmission delay of each impairment generator channel
= 5.9 msec (channel residual delay)
+ group delay distortion filter transmission delay
+ 1.8 msec; IMD transmission delay (if on, with Standard Option)
+ 0.5 msec x n ; PCM transmission delay, where n = number of active PCM links
+ programmed satellite delay time

The equation for the impairment generator channel can also be written as follows to determine the magnitude of satellite delay that is required to achieve a specific value of total transmission delay:

Programmed satellite delay time
= desired total channel delay
- 5.9 msec (channel residual delay)
- group delay distortion filter transmission delay
- 1.8 msec; IMD transmission delay (if on, with Standard Option)
- 0.5 msec x n ; PCM transmission delay, where n = number of active PCM links

For example, if the "EIA A" gain filter along with the "EIA 1" delay filter are selected with IMD and one link of PCM on (enabled), and a total round trip delay of 80.0 msec is desired, then satellite delay is calculated as illustrated below.
TAS 182:

- Required delay for each channel
= desired round trip delay/2
= 40.0 msec
- Programmed satellite delay time for each channel
= 28.2 msec
= 40.0 msec - 5.9 msec - 2.9 msec - 1.8 msec - 0.5 msec

- **TAS 151 or 152**

Total transmission delay of each impairment generator channel
= 3.1 msec (channel residual delay)
+ group delay distortion filter transmission delay
+ programmed satellite delay time
+ 1.2 msec; PCM transmission Delay (if on)

Total transmission delay of TAS 151 channel without impairment generator
= 0.4 msec (channel residual delay)

The equation for the impairment generator channel can also be written as follows to determine the magnitude of satellite delay that is required to achieve a specific value of total transmission delay:

Programmed satellite delay time

- = desired total channel delay
- 3.1 msec (channel residual delay)
- group delay distortion filter transmission delay
- 1.2 msec; PCM transmission delay (if on)

For example, if the "EIA A" gain filter along with the "EIA 1" delay filter are selected, and a total round trip delay of 80.0 msec is desired, then satellite delay is calculated as illustrated below.

TAS 151:

- Required delay for impairment generator channel
 - = desired round trip delay - residual delay of channel without impairment generator
 - = 79.6 msec
- Programmed satellite delay time for the impairment generator channel
 - = 72.4 msec
 - = 79.6 msec - 3.1 msec - 1.2 msec

TAS 152:

- Required delay for each channel
 - = desired round trip delay/2
 - = 40.0 msec
- Programmed satellite delay time for each channel
 - = 32.8 msec
 - = 40.0 msec - 3.1 msec - 1.2 msec

The polarity control feature provided by the TAS 100 Series causes the far echo signal to be added to the modem's receive signal with no phase shift or with 180 degrees of phase shift. It is provided for completeness, but unlike near echo it typically has no significant effect.

The TAS 100 Series allows the user to control the receive signal level to far talker echo level ratio. The value of far echo attenuation that is required to create the desired ratio can be determined from the following expressions:

Station A Far Echo Attenuation (positive or negative value in dB)

= Desired receive signal to far echo ratio for modem A (positive value in dB)

- TAS 100 Series B→A input level (negative value in dBm)

+ TAS 100 Series A→B output level (negative value in dBm)

Station B Far Echo Attenuation (positive or negative value in dB)

= Desired receive signal to far echo ratio for modem B (positive value in dB)

- TAS 100 Series A→B input level (negative value in dBm)

+ TAS 100 Series B→A output level (negative value in dBm)

These equations assume that the A→B input level of the TAS 100 Series is set equal to the transmit signal level present at station A. In addition, the B→A input level of the TAS 100 Series must be set equal to the transmit signal level present at station B. This means that if external loop simulation (TAS 240) is being used, the TAS 100 Series input level should be set to the modem's transmit level minus the loss produced by the loop. When loop simulation is not used, the TAS 100 Series input level should be set to the modem's transmit level.

The following example will illustrate the far talker echo feature of the TAS 100 Series.

Example User Test Conditions:

- Modem A and modem B transmit level = -9.0 dBm
- Desired 1004 trunk loss = 7.0 dB
- Loop loss = 0.0 dB (no external 2-wire loops)
- Gain distortion in both channels = flat
- Delay distortion in both channels = flat
- Desired receive signal to far end talker echo ratio at station B = 10.0 dB
- Desired receive signal to far end talker echo ratio at station A = 32.0 dB

TAS 100 Series Parameter Values:

- A→B input level = -9.0 dBm = transmit level at station A interface
- A→B output level = -16.0 dBm = A→B input level - desired 1004 Hz loss
- B→A input level = -9.0 dBm = transmit level at station B interface
- B→A output level = -16.0 dBm = B→A input level - desired 1004 Hz loss
- Far A Echo Attenuation = 25.0 dBm = 32.0 dB - (-9.0 dBm) + (-16.0 dBm)
- Far B Echo Attenuation = 3.0 dBm = 10.0 dB - (-9.0 dBm) + (-16.0 dBm)

Listener Echo

The TAS 100 Series provides listener echo simulation for station A and station B. Station B (A) listener echo is the reflection of the modem B (A) receive signal. The simulation method used by the TAS 100 Series is the same as that specified in modem testing standards issued by the Electronic (Telecommunications) Industries Association (EIA/TIA) and CCITT. The simulation technique is illustrated in Figure 3-10, where the level of listener echo is controlled by the combination of the station A far echo attenuation and the station B far echo attenuation. The time delay of listener echo is determined by the satellite delay in the A→B and B→A directions.

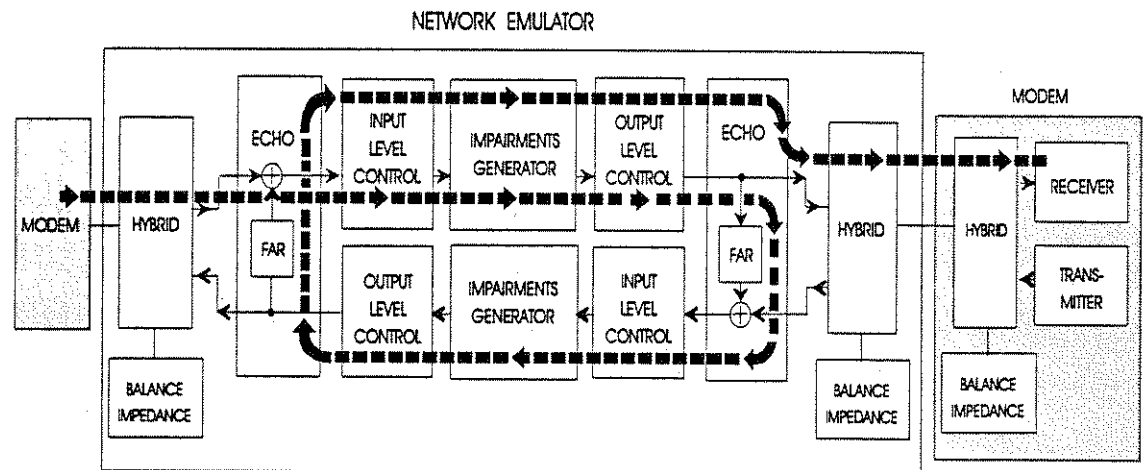

Figure 3-10. EIA/CCITT Listener Echo

The EIA method does not allow listener echo simulation that is independent of far talker echo. The listener echo level is determined by the far talker echo level. As a result, the receive signal to listener echo ratio is dictated by the combination of the station A receive signal to far talker echo ratio plus the station B receive signal to far talker echo ratio, as expressed below:

Station A or B Receive Signal to Listener Echo Ratio
 (positive value in dB)
 = Desired receive signal to far echo ratio for modem A
 (positive value in dB)
 + Desired receive signal to far echo ratio for modem B
 (positive value in dB)

3.4. Measurement/Monitoring

The TAS 100 Series includes an internal measuring device that provides the capability to measure the level of a transmission signal. In addition a programmable internal audio monitor is provided as well as selectable access points for external signal measurement and analysis.

3.4.1. Level Measurement Module

The Signal Measurement Module provides the capability to perform an RMS level measurement. The level of a signal over the range of +10.0 dBm to -50.0 dBm can be measured. These measurements can be performed on any 1 of 6 user signals. The signals that are available for measurement include:

- Station A Transmit Signal (A0)
- Station B 4-Wire Receive Signal (B1)
- Station B 2-Wire Receive Signal (B2)
- Station B Transmit Signal (B0)
- Station A 4-Wire Receive Signal (A1)
- Station A 2-Wire Receive Signal (A2)

Figure 3-12 illustrates the locations where a measurement is performed for the 4-wire network configuration, and Figure 3-11 illustrates the location for 2-wire network configurations. Three of the measurement locations are in the A to B direction and three are in the B to A direction.

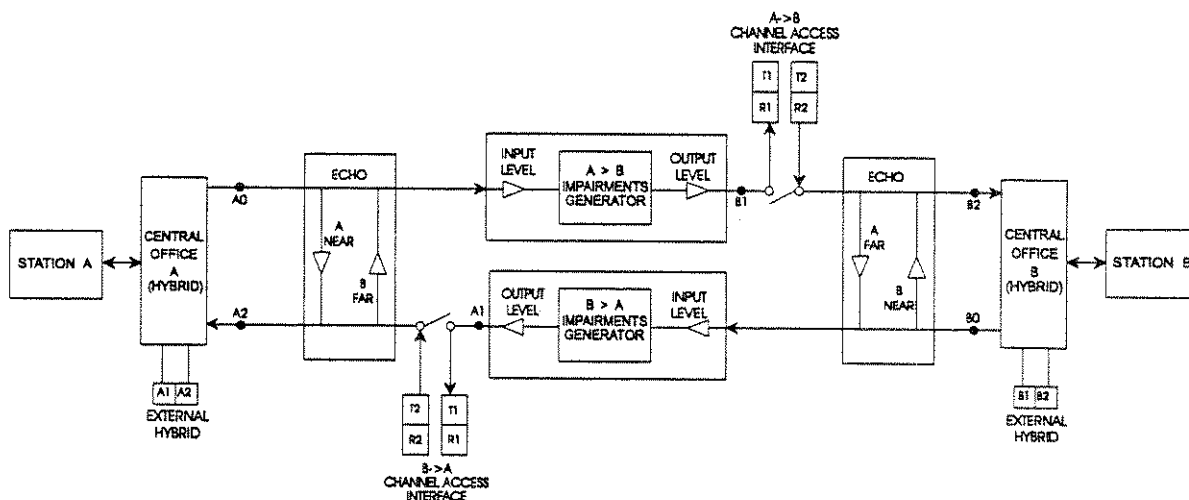

Figure 3-11. 2-Wire Configuration Measurement/Monitor Locations

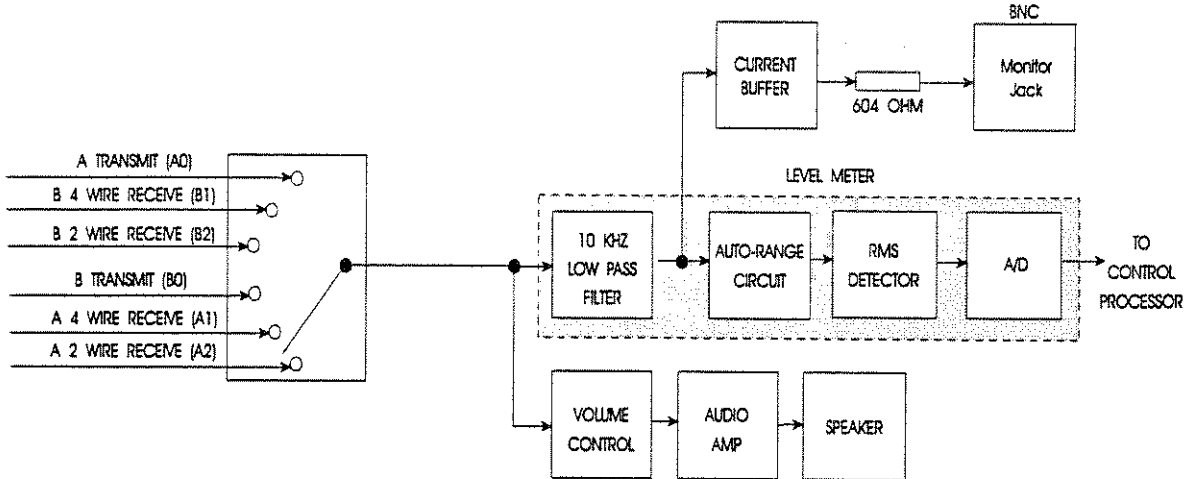

Figure 3-13. Measurement and Monitor Circuit Block Diagram

The signal multiplexer selects 1 out of 6 available signals for input to the measurement module. The output of the signal multiplexer is input to the low pass filter.

The low pass filter is a 2nd order butterworth filter with a 3 dB (cutoff) frequency at 10 kHz. This filter removes high frequency noise from the measurement signal. The output of the low pass filter is input to the auto range circuit.

The auto range circuit contains both programmable gain and attenuation. The primary function of the auto range circuit is to provide the optimum focus on the measurement signal to allow an accurate detection of its RMS power level. The concept is somewhat analogous to adjusting the magnification on a microscope to achieve the optimum view of a small object. This circuit allows the measurement of signals over a large range of levels, from -50.0 dBm to +10.0 dBm.

The RMS detector circuit takes its input from the auto range circuit and generates a DC voltage that is equal to the RMS AC signal level. This DC output signal is input to the A/D converter.

The primary function of the A/D is to convert the analog DC voltage output of the RMS detector circuit into a digital word to be read by the Control Processor.

Measurement Algorithm

The level measurement technique is based upon the following operations:

- Measurement signal selection
- Measurement signal level translation (auto range)
- RMS detection

- Data acquisition

The signal level reported by the TAS 100 Series is an arithmetic average that is determined by calculating the sum of 10 RMS level measurements and dividing it by 10.

3.4.2. Monitoring

The TAS 100 Series provides an audible output for the transmission signals in either the A→B or B→A direction. A scope monitor port is provided to support the external monitoring of signals.

Audio

The signal that is input to the audio monitor is selected from the measurement multiplexer as illustrated in Figure 3-13. The level of this signal is scaled to provide volume control before it is amplified and connected to a speaker that is mounted inside of the front panel.

Monitor Jack

The TAS 100 Series has a rear panel BNC connector that provides external monitoring on signals in both directions of transmission. The monitor signals are selected by the signal multiplexer illustrated in Figure 3-13. The monitor signal is available at the rear panel jack labeled "600 OHM MONITOR". The jack is buffered and driven by a 604 ohm source impedance. The external device that is connected to these ports should provide a 604 ohm termination. When the jack is terminated the following monitor signals will appear at the monitor jack at the correct level:

- Station B 4-Wire Receive Signal (B1)
- Station B 2-Wire Receive Signal (B2)
- Station A 4-Wire Receive Signal (A1)
- Station A 2-Wire Receive Signal (A2)

However, a 604 ohm termination at the monitor jack will cause the Station A Transmit Signal (A0) and the Station B Transmit Signal (A0) to be measured 6 dB below their actual level.

3.5. Central Office Emulation

The TAS 100 Series emulates the characteristics of the voiceband telephone network. The telephone network consists of transmission facilities and switching facilities. The transmission equipment is interconnected with switching equipment to create communication channels. This switching equipment and other types of interface equipment is located in a telephone company building referred to as a Central Office. The characteristics of this type of Central Office equipment is emulated by the Central Office emulation module of the TAS 100 Series.

The Central Office features are organized into four functional groups consisting of:

- Exchange Configuration Features
- Loop Signaling Features
- Call Progress Tones and Switching Features
- Dialing Analysis Features.

Exchange configuration features include the emulation of different types of traffic networks such as Private Line Data Networks and Public Switched Telephone Networks (PSTN). In addition, a variety of other configuration features such as loopback mode indication, hybrid balance selection, 4-wire channel access in 2-wire mode, programmable data jack, make busy and switched network status are provided.

Flexible loop signaling features include a programmable constant current source. The ringing generator also provides many features such as programmable level, frequency, DC bias and polarity. In addition call progress tones and ringing can be manually sent to either station.

Comprehensive emulation of programmable call progress tones and automatic switching features allow the emulation of international signaling conditions.

The dialing analysis features allow the DTMF (touch-tone) and dial pulse functions of a switched network DCE to be tested.

3.5.1. Exchange Configuration Features

The unique exchange configuration features provided by the TAS 100 Series are discussed below.

Network Traffic Configurations

The transmission and switching facilities of the telephone network are configured to carry specific types of communications traffic. The types of traffic networks supported by the TAS 100 SERIES include:

- 4-Wire Private Network
- 2-Wire Switched Network
- 2-Wire Auto Switched Network
- 2-Wire Private Network

4-Wire Private Network Configuration

Figure 3-14 shows a TAS 100 Series 4-wire private network configuration. This configuration supports two 4-wire, 600 ohm stations referred to as station A and station B. The two stations are connected on a continuous basis by a dedicated transmission channel in each direction.

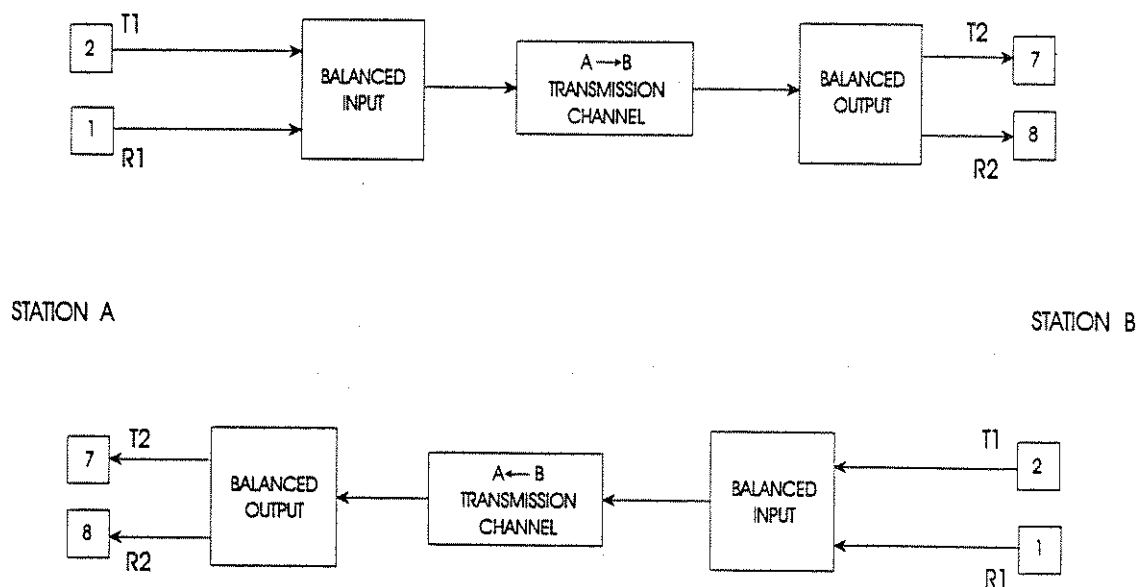

Figure 3-14. 4-Wire Private Network Connection

2-Wire Switched Configuration

Figure 3-15 illustrates a TAS 100 Series station interface for 2-wire switched network configuration. The 4-wire portion of this circuit provides the impairments simulation in both directions. A 2 to 4 wire interface circuit (hybrid) sits at each end of the 4-wire circuit. The 2-wire side of each hybrid is available for connection to a 2-wire station. A transmission from station A to station B passes through the impairments generator dedicated to the A→B direction, and a transmission from station B to station A passes through the impairments generator dedicated to the B→A direction.

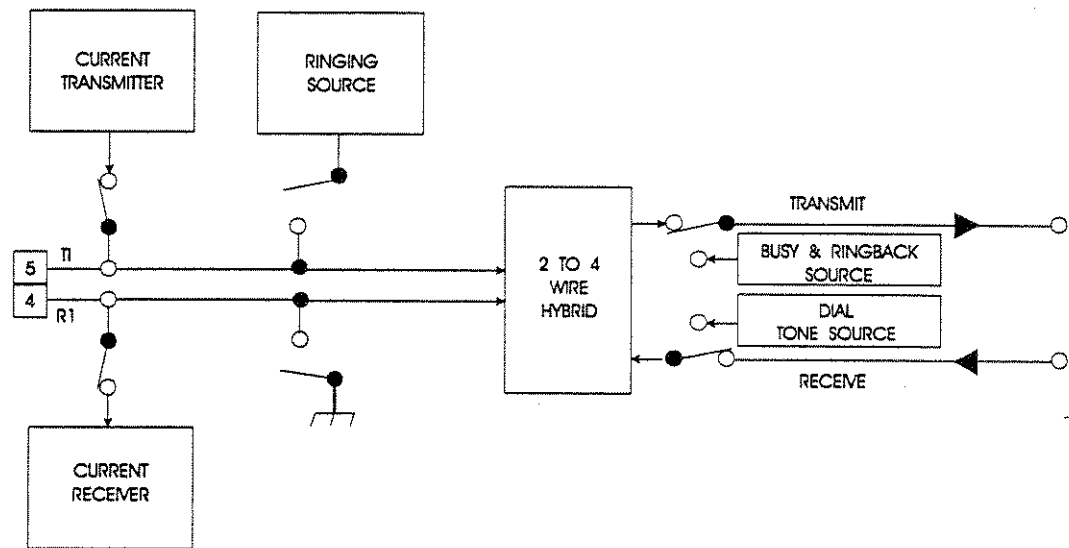

Figure 3-15. 2-Wire Switched Network Configuration Station Interface

The TAS 100 Series provides 2-wire switched network emulation with a programmable current source/sink. The 2-wire switched network emulation also provides audible ringing (ringback), busy, and dial tone sources at the 4-wire side of each hybrid. Each of these sources is programmable. For each 2-wire station, the dial tone source originates at the near end of the circuit, and the ringback and busy sources originate at the far end of the circuit. This configuration accurately simulates the actual switched network.

The switched network emulation automatically detects DTMF (touch-tone) or dial pulse signaling from each 2-wire station, and automatically performs loop-start signaling to process calls. Calls may be placed in either direction (A to B or B to A). Processing of a typical call from station A to B (B to A) proceeds as follows:

1. Station set A (B) goes off-hook.
2. The central office emulator provides dial tone to station A (B).
3. Station A (B) begins dialing using DTMF or pulse signaling.

4. The central office emulator receives the dialed digits. When the quantity of digits dialed is equal to the quantity of digits for the station B (A) telephone number, the central office emulator compares the dialed number to the station B (A) number. If the number is correct and station B (A) is on-hook, the central office emulator provides a path between the two stations, rings station B (A), and provides audible ringing to station A (B). If the number is correct, but station B (A) is off-hook, the central office emulator does not ring station B (A). Instead, station A (B) receives a busy signal until station A (B) goes back on-hook. If the number is not correct, the central office emulator does not provide a path between the stations, and does not ring station B (A). In this event, station A (B) receives a busy signal until it goes back on-hook.
5. If the number was dialed correctly, station B (A) detects ringing and goes off-hook.
6. The central office emulator stops ringing station B (A), and stops providing audible ringing to station A (B).
7. Stations A and B can now communicate between each other via the transmission channels in the TAS 100 Series. The central office emulator continues to provide the connection until either station goes on-hook.

2-Wire Auto Switched Configuration

The 2-wire auto switched configuration is similar to the 2-wire switched configuration except that all signaling functions are disabled. The loop current is active and is used to establish a connection through the emulator. When either station goes off hook, loop current flows but no call establishment functions (dial tone, etc.) are enabled. When the second station goes off hook, loop current is detected and a connection is established between station A and B. When either station goes back on hook, the connection between stations is broken.

2-Wire Private Line Configuration

A 2-wire private network configuration is similar to the 2-wire switched configuration, except that all switching, signaling and loop current functions are disabled. This configuration provides two 2-wire stations with a hybrid at either end of the transmission path. The two stations are connected on a continuous basis by a dedicated transmission channel in each direction.

4-Wire Private /2-Wire Switched (GT-Cellular Lite) Network Configuration

Figure 3-16 shows a TAS 182 4-wire private/2-wire switched network configuration. This configuration support a 4-wire 600 ohm device at station A and a 2-wire 600 ohm device at station B. The 4-wire portion of this circuit provides impairment simulation in both directions. A 2 to 4 wire interface circuit (hybrid) sits at the 'B' side of the 4-wire circuit.

There are two ways to establish connection in this configuration based on the originator. If station B is to establish the connection, the station B ring interval must be disabled and B can dial to connect. In order to emulate station A call establishment, station B must have forced signalling - ringing sent. When station B goes off hook a connection is established.

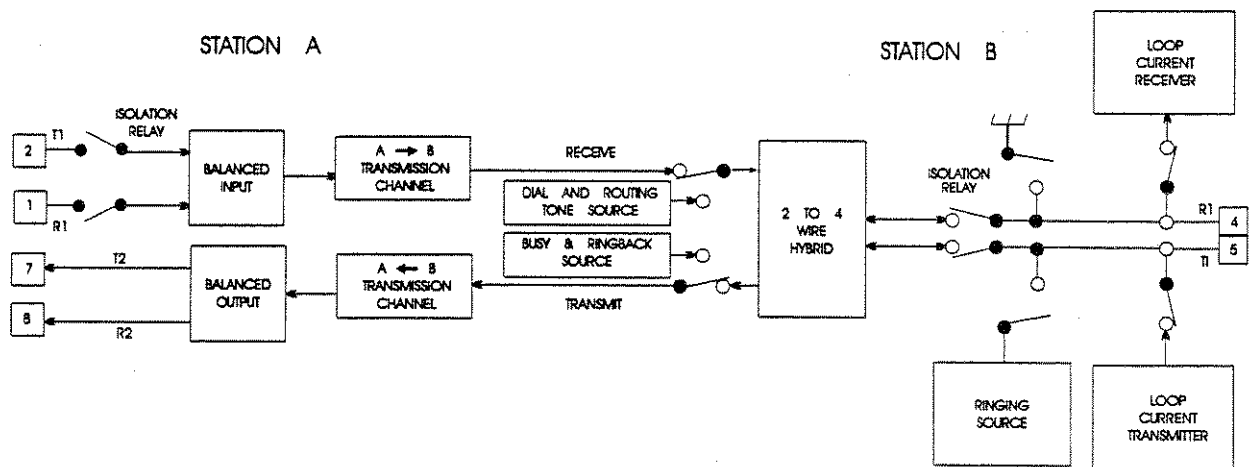

Figure 3-16. 4-Wire Private/2-Wire Switched Network Configuration

3.5.2. 4-Wire Configuration Features

The vast majority of exchange configuration features, loop signaling features, call processing features, and dialing analysis features are not applicable to the 4-wire private network traffic configuration. The primary exception is the loopback mode indicator feature.

Loopback Mode Indicator (MI)

This feature is available in the 4-wire private configuration only. Relay contacts are provided to control electrical continuity between terminals 3 and 6 on the 8 contact station set interface. An open circuit between these pins indicates that the loopback mode is active and that the line is not available for transmission. This simulates a loopback of a leased line toward the central office or an out-of-service condition. A short circuit between pins 3 and 6 indicates that the loopback mode is inactive. This relay is specified in the EIA TR30.3 Telecommunications Systems Bulletin No. 18.

The status (active or inactive) of the mode indicator can not be changed while the TAS 100 SERIES is setup in any of the 2-wire configurations. An open circuit will be present between terminals 3 and 6 for the 2-wire configurations. Control information for the mode indicator will be accepted and saved while the unit is in 2-wire mode but will not be executed until the 4-wire configuration is selected.

3.5.3. 2-Wire Configuration Features

The TAS 100 Series supports some unique features for its 2-wire network configurations. The external hybrid balance feature, 4-wire channel access in 2-wire mode and programmable data jack feature are available for all 2-wire configurations. However, the make busy feature and switched network status feature are applicable to 2-wire switched operation only.

Hybrid Balance

This feature is functional for all 2-wire network traffic configurations. In 2-wire configurations this feature allows the user to select between a TAS 100 Series internally supplied 604 ohm resistor or an external user supplied balance impedance. The external impedance for the hybrid at Station A must be connected between the terminals labeled "A1" and "A2" on the TAS 100 Series rear panel "Balance Network" terminal block. Likewise, the external impedance for the hybrid at Station B must be connected between the terminals labeled "B1" and "B2".

The 2-wire station interfaces of the TAS 100 Series are connected to the four wire transmission channels through devices called hybrids. A hybrid is a four-port device used to separate signals traveling in both directions along a single pair of

wires (2-wire) into individual directions (4-wire), and to recombine those signals traveling on 4-wire circuits for use at the 2-wire interface.

The TAS 100 Series hybrids have a transmit transmission channel and a receive transmission channel connected to two of its four ports, the 2-wire station interface to the third port, and the balance network connected to the fourth port. If the impedance of the balance network is equal to the impedance at the 2-wire port over the frequency range of the signal, then the transmit and receive ports are conjugate ports, that is, these ports are decoupled. The magnitude of decoupling is expressed as trans-hybrid loss. A ideal hybrid would have an infinite trans-hybrid loss.

An external balance impedance is used in applications where the internal 604 ohm balance impedance does not provide an adequate impedance match (trans-hybrid loss).

External 4-Wire Channel Access in 2-Wire Mode

This feature is functional for all 2-wire network traffic configurations. In 2-wire configurations this feature allows the user to insert an external device in Series with either the A→B or B→A transmission channel of the TAS 100 Series. When this feature is enabled the selected transmission channel is open circuited just after the internal channel as illustrated in Figure 3-17. Access to both sides of this open circuit is then provided by the rear panel terminal block labeled "A→B" and "B→A".

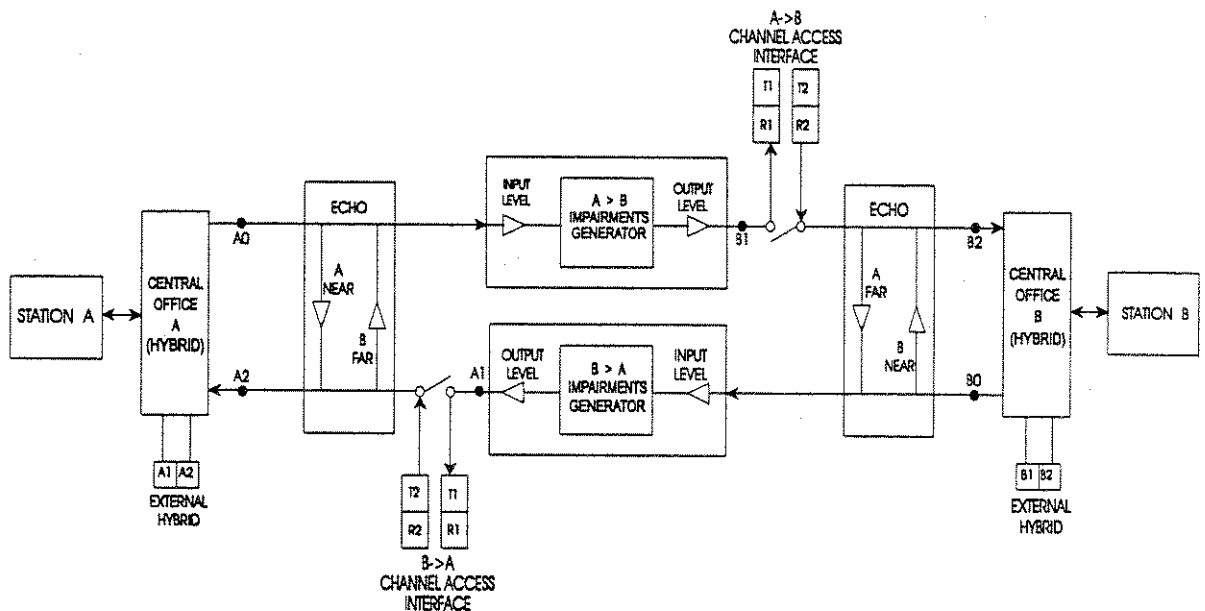

Figure 3-17. External Channel Access Interfaces

Terminals T2/R2 form a balanced (differential) input interface that presents a 600 ohm termination. Terminals T1/R1 form a balanced (differential) output interface with a 600 ohm source impedance. Terminals T1/R1 would connect to the input of an external device and terminals T2/R2 would connect to the output of an external device.

This feature is typically used in situations where it is desired to provide transmission channel simulation other than that supplied by the internal channels of the TAS 100 Series. In such a situation the external channel access is enabled and an externally supplied channel simulator inserted.

Reverse Polarity Signaling

Reverse Polarity signaling is a method some telephone networks employ to indicate to the calling station the hook status of the answer station (Japan is one such country which uses this signaling technique). It serves as feedback to the station that receives it.

When reverse polarity signaling is enabled, the battery relationship of the calling station on the two loop conductors (tip to ring) is reversed on answer. This type of signaling scheme is made up of four cases, dependent on the polarities of the calling and the answer stations when on hook. The following tables show these four cases. For the purpose of illustration the tables are oriented with station A being the calling station and station B being the called or answer station. In actual operation either station may initiate the call.

Case 1: Calling Station is **POSITIVE** when on hook.
 Answer Station is **POSITIVE** when on hook.

<i>Line Status</i>	<i>Calling Station (A) DC Polarity</i>	<i>Called Station (B) DC Polarity</i>
A on-hook & B on-hook	POSITIVE	POSITIVE
A off-hook & A dial tone	POSITIVE	POSITIVE
Dialing Complete B ringing & A ringback	POSITIVE	NEGATIVE
B answer & A/B connect	NEGATIVE	POSITIVE
B on-hook or A on-hook	POSITIVE	POSITIVE

Table 3-3. Reverse Polarity Signalling - Case 1

Case 2: Calling Station is **POSITIVE** when on hook.
 Answer Station is **NEGATIVE** when on hook.

<i>Line Status</i>	<i>Calling Station (A) DC Polarity</i>	<i>Called Station(B) DC Polarity</i>
A on-hook & B on-hook	POSITIVE	NEGATIVE
A off-hook & A dial tone	POSITIVE	NEGATIVE
Dialing Complete B ringing & A ringback	POSITIVE	POSITIVE
B answer & A/B connect	NEGATIVE	NEGATIVE
B on-hook or A on-hook	POSITIVE	NEGATIVE

Table 3-4. Reverse Polarity Signaling - Case 2

Case 3: Calling Station is **NEGATIVE** when on hook.
 Answer Station is **POSITIVE** when on hook.

<i>Line Status</i>	<i>Calling Station(A) DC Polarity</i>	<i>Called Station(B) DC Polarity</i>
A on-hook & B on-hook	NEGATIVE	POSITIVE
A off-hook & A dial tone	NEGATIVE	POSITIVE
Dialing Complete B ringing & A ringback	NEGATIVE	POSITIVE
B answer & A/B connect	POSITIVE	POSITIVE
B on-hook or A on-hook	NEGATIVE	POSITIVE

Table 3-5. Reverse Polarity Signaling - Case 3

Case 4: Calling Station is **NEGATIVE** when on hook.
 Answer Station is **NEGATIVE** when on hook.

<i>Line Status</i>	<i>Calling Station (A) DC Polarity</i>	<i>Called Station (B) DC Polarity</i>
A on-hook & B on-hook	NEGATIVE	NEGATIVE
A off-hook & A dial tone	NEGATIVE	NEGATIVE
Dialing Complete B ringing & A ringback	NEGATIVE	NEGATIVE
B answer & A/B connect	POSITIVE	NEGATIVE
B on-hook or A on-hook	NEGATIVE	NEGATIVE

Table 3-6. Reverse Polarity Signaling - Case 4

Program Resistor (Programmable Data Jack)

This feature is available in all 2-wire configurations only. It provides a programmable data jack arrangement for modems that are capable of operating in program mode. An 866 ohm resistor or an open circuit may be applied between terminals 7 and 8 of the eight terminal station set interface of the TAS 100 Series. The presence of the 866 ohm resistor signals the modem to transmit at a level of -4 dBm.

This data jack arrangement is specified in the EIA-496-A standard.

The status (open circuit or 866 ohms) of the program resistor can not be changed while the TAS 100 SERIES is setup in the 4-wire configurations. Terminals 7 and 8 are used to supply the receive signal (emulator output) for the 4-wire configuration. Control information for the program resistor will be accepted and saved while the unit is in 4-wire configuration but will not be executed until a 2-wire configuration is selected.

Make Busy

This feature is functional for the 2-wire switched network configuration and can only be controlled by the remote command (SG,M).

In 2-wire switched configuration this feature forces the originating station to encounter a busy condition by making the answer station appear busy. When "make busy" is enabled at the answer station the originating station will receive a busy tone at the completion of the dialing sequence independent of the availability of the answer station.

This feature can be used to test the response of a station set device such as a modem, when a busy tone is encountered during call setup.

Switched Network Status

The TAS 100 Series is capable of reporting the status of either the Station A or Station B interface. This includes hook status, connect status, dialing status, signaling tone and ringing status. Hook status reports if the station set device is on-hook or off-hook. Connect status indicates if the two stations are currently connected (call established). Dialing status specifies if the TAS 100 Series is expecting DTMF (touch-tone) or dial pulse information from the originating station while the dialing sequence is in process. In addition the status of primary dial tone, busy tone, ringback and high voltage ringing is provided.

3.5.4. Loop Current Generator

A DC loop current generator is provided by the TAS 100 Series to support Loop Start signaling. Loop Start signaling is a form of supervisory signaling that uses DC current to indicate the desire to originate a call or to indicate answer at the called station. The TAS 100 Series uses this type of signaling to detect hook status (on-hook or off-hook).

During its on-hook state a telephone or DCE prevents DC current flow between tip and ring by creating an open circuit (high impedance). When it goes off-hook it creates a low DC impedance to allow DC current to flow. The 2-wire switched and 2-wire auto-switched configurations of the TAS 100 Series interpret the presence of DC current flow between tip (pin 5) and ring (pin 4) as an off-hook condition. The absence of DC current flow is interpreted as an on-hook condition.

Constant Current Source

The TAS 100 Series loop current generator is a constant current source. The constant current source is independently controlled at each station interface and is designed to generate a programmed level (8 mA to 120 mA) of loop current. This is accomplished with a constant current transmitter and a constant current receiver. The DC loop current originates from the transmitter, flows through the telephone or modem into the current receiver. The loop current level is constant and independent of the magnitude of loop resistance (total resistance between tip and ring). This independence is maintained until the voltage across tip and ring exceeds the compliance voltage of approximately 30 volts.

Loop Current Polarity

The loop current generator of the TAS 100 Series can supply current with a positive or negative polarity. Positive polarity means that loop current flows from tip to ring. Negative means that current flows from ring to tip.

The loop current generator power supply (battery) is configured to float relative to earth (frame) ground. This means the DC voltage that is formed across tip (pin 5) and ring (pin 4) by the loop current is not referenced to earth ground.

3.5.5. Ringing Generator

The TAS 100 Series provides a user programmable ringing generator to support emulation of the Public Switched Telephone Network (PSTN). This generator is used to alert the answer station of an incoming call.

Ringing is a high voltage low frequency AC signal that is superimposed on a DC bias voltage (battery). It is comprised of a single frequency (typically 20 or 25 Hz) sine wave that is offset (biased) on a 42 volt DC voltage. The AC level, frequency and cadence of ringing can be controlled, where the cadence is the same as that specified for ringback.

The cadence (on/off times) of ringing will be identical to that of ringback. Ringback will be generated to the originating station whenever ringing is being generated to the answer station.

The TAS 100 Series ringing generator is designed to support a telephone or modem that represents a load of one Ringer Equivalence Number (REN). This type of load presents an AC impedance of approximately 7000 ohms at the ringing frequency and a high DC impedance.

The TAS 100 Series sends ringing to the called station by automatically performing the following operations:

- Disconnects the programmable loop current generator.
- Disconnects tip (pin 5) and ring (pin 4) from the 2-wire to 4-wire hybrid circuit and connects the positive potential of the bias voltage to the tip conductor.
- Connects the AC ringing signal with a negative bias potential to the ring conductor.

In 2-wire switched configuration, the TAS 100 Series will automatically disconnect ringing (trip ringing) when it detects 12 mA or more of DC current flow from the bias voltage source. The telephone or modem generates a path for DC current flow when it makes an on-hook (high DC impedance) to off-hook (low DC impedance) transition to answer the call.

The TAS 100 Series performs ring trip at the called station by automatically performing the following operations:

- Disconnects ringing generator from tip (pin 5) and ring (pin 4) and connects the 2-wire to 4-wire hybrid circuit.
- Connects the programmable loop current generator.

3.5.6. Call Progress Tones and Switching Features

The TAS 100 Series provides flexible call progress and switching features that can support virtually all U.S. and international signaling formats.

Primary Dial Tone

Primary (First) dial tone is provided by the TAS 100 Series when the unit is configured for 2 wire switched operation. It is an audible tone that is supplied to the station interface following an off hook transition. The tone provides an indication to the telephone set or modem that has dialing priority (see Dial Priority section below) that the TAS 100 Series is ready to receive dial signals (dial pulses or DTMF).

Primary dial tone is a signal comprised of two single frequency sine waves. The frequency of each sine wave can be controlled. In addition the level and cadence (on/off times) of the composite wave form can be specified. This wave form originates from the near end Central Office of the TAS 100 Series and does not traverse the impairments channel. As a result the dial tone signal is not subjected to the simulated transmission impairments.

A single frequency primary dial tone can be generated by specifying frequency 1 and frequency 2 to be the same. In this case the two sine waves are summed together in phase to produce a single frequency tone with a level that is 3 dB higher than the programmed value. Dial tone level is calibrated for a dual tone signal that consists of tones of unequal frequencies. Two tones of unequal frequencies produce a signal that is 3 dB lower than that generated by two tones of identical frequencies and phase.

A continuous tone will be generated whenever all off times of the cadence are zero and there is a non-zero on time (on time 3). A single stage cadence (one non-zero on time and one non-zero off time) should be specified using on time 3 and off time 3. A two stage cadence (two non-zero on times and two non-zero off times) should be specified using on time 2 and off time 2 for the first stage along with on time 3 and off time 3 for the second stage. A three stage cadence (three non-zero on times and three non-zero off times) should be specified using on time 1 and off time 1 for the first stage, along with on time 2 and off time 2 for the second stage and on time 3 and off time 3 for the third stage.

Secondary Dial Tone

Secondary dial tone is provided by the TAS 100 Series when the unit is configured for 2 wire switched operation. It is an audible tone that is generated to the station interface of the originating device when the dialing sequence reaches a predetermined intermediate point of the specified telephone number. The tone

provides an indication to the originating telephone set or modem, that the portion of the telephone number that has been dialed matches that specified for the answer station, and that it may resume with sending dial signals (dial pulses or DTMF) for the next segment of the telephone number.

The characteristics (frequency, level, and cadence) of secondary dial tone cannot be independently programmed and are identical to those of primary dial tone.

Secondary dial tone is used in the call setup sequence by specifying a telephone number that includes a "+" (plus sign) at the point where the secondary dial tone is desired. The following example illustrates the use of the plus sign to generate a secondary dial tone. In this example Station A is the originate station and the telephone number of Station B (answer station) is 555+987.

Secondary dial tone example:

- Station A goes off hook and receives the first dial tone after dial tone delay expires.
- Station A dials 555 (first dial tone is turned off when 1st digit is dialed).
- Station A receives secondary dial tone after network routing delay expires.
- Station A dials 987.
- Station B receives ringing and Station A receives ringback (audible ringing) after network routing delay expires.

Busy Tone

Busy tone is provided by the TAS 100 Series when the unit is configured for 2 wire switched operation. It is an audible tone that is supplied to the station interface of the originating device when the desired answer station is unavailable. The tone provides an indication to the originating telephone set or modem that the desired answer station is busy (unavailable) because it is currently off hook, (a "make busy" condition is active; see Make Busy description in Exchange Configuration section) or the dialed telephone number does not match that specified for the desired answer station (wrong number).

Busy tone is a signal comprised of two single frequency sine waves. The frequency of each sine wave can be controlled. In addition the level and cadence (on/off times) of the composite wave form can be specified, where the level is the same as that specified for transmission channel output. The busy signal originates from the far end Central Office of the TAS 100 SERIES at a level of 0 dBm and then traverses the impairments channel. As a result the busy signal is subjected to

the simulated transmission impairments that are present in the transmission direction that terminates at the originating station.

Busy tone is encountered by the originating station when the answer station is not available. The following example illustrates a situation in which Station A (originating station) would receive a busy tone. In this example the telephone number of Station B (answer station) is 5559876 and the output level of the B to A transmission channel is -23.5 dBm.

Busy tone example:

- Station A goes off hook and receives the first dial tone after dial tone delay expires.
- Station A dials 5449877 (wrong number).
- Station A receives busy signal at -23.5 dBm after network routing delay expires.

A single frequency busy tone can be generated by specifying frequency 1 and frequency 2 to be the same. In this case the two sine waves are summed together in phase to produce a single frequency tone with a level that is 3 dB higher than the programmed value. Busy tone level is calibrated for a dual tone signal that consists of tones of unequal frequencies. Two tones of unequal frequencies produce a signal that is 3 dB lower than that generated by two tones of identical frequency and phase.

A continuous tone will be generated whenever the off time of the cadence is zero and the on time is non-zero.

Ringback (Audible Ringing)

Ringback is provided by the TAS 100 Series when the unit is configured for 2 wire switched operation. It is an audible tone that is supplied to the station interface at the completion of a dialing sequence. The tone provides an indication to the originating telephone set or modem that the call has been routed to the addressed station (answer station) and that an alerting signal (ringing) is being applied to the answer station.

Ringback tone is a signal comprised of two single frequency sine waves. The frequency of each sine wave can be controlled. In addition the level and cadence (on/off times) of the composite wave form can be specified, where the level is the same as that specified for transmission channel output. The ringback signal originates from the far end Central Office of the TAS 100 Series at a level of 0 dBm and then traverses the impairments channel. As a result the ringback signal is subjected to the simulated transmission impairments that are present in the transmission direction that terminates at the originating station.

A single frequency ringback signal can be generated by specifying frequency 1 and frequency 2 to be the same. In this case the two sine waves are summed together in phase to produce a single frequency ringback with a level that is 3 dB higher than the programmed value. Ringback level is calibrated for a dual tone signal that consists of tones of unequal frequencies. Two tones of unequal frequencies produce a signal that is 3 dB lower than that generated by two tones of identical frequency and phase.

The cadence of ringing (alerting) will be identical to that of ringback. Ringing will be generated to the answer station whenever ringback is present at the original station. A continuous ringback and ringing will be generated whenever all off times of the cadence are zero and there is a non-zero on time (on time 3). A single stage cadence (one non-zero on time and one non-zero off time) should be specified using on time 3 and off time 3. A two stage cadence (two non-zero on times and two non-zero off times) should be specified using on time 2 and off time 2 for the first stage along with on time 3 and off time 3 for the second stage. A three stage cadence (three non-zero on times and three non-zero off times) should be specified using on time 1 and off time 1 for the first stage, along with on time 2 and off time 2 for the second stage and on time 3 and off time 3 for the third stage.

Telephone Numbers

The Public Switched Telephone Network (PSTN) is emulated by the TAS 100 Series when the unit is configured for 2 wire switched operation. This emulated PSTN consists of two network (station) interfaces. The network address (telephone number) of each station can be specified. This address is a sequence of numbers that identifies the station set (A or B) to which a call is directed.

The TAS 100 Series supports a telephone number sequence that can be as short as one character or as long as fifteen characters. This dial information may be sent to the TAS 100 Series using dial pulsing or Dual Tone Multi Frequency (DTMF). Dial digits 0 to 9 are supported for both dial pulsing and DTMF (touch-tone), as well as # (pound) and * (star) for DTMF only dialing. In addition, a "+" (plus sign) functions as a special character to control the occurrence of secondary dial tone. A telephone number may include a "+" (plus sign) at the point in the dialing sequence where the secondary dial tone is desired (see Secondary Dial Tone section 3.5.7.2).

The TAS 100 Series automatically senses the type (DTMF or dial pulsing) of signaling that is being used to send dialing information. This sensing is done on the first character of a dialing sequence. The TAS 100 Series will only recognize (accept) subsequent characters that match the type of the first character.

Dial Priority

The Central Office emulator module of the TAS 100 Series receives dialing information (DTMF or dial pulsing) from only one station at a time. The emulator assigns the common DTMF/dial pulse detector to the first station (A or B) that makes an on-hook to off-hook transition, assuming that both stations are on-hook at the start. The station that does not have dial priority will not be allowed to dial. DTMF or dial pulses will be ignored and dial tone will not be interrupted.

Network Delays

The Public Switched Telephone Network (PSTN) is emulated by the TAS 100 Series when the unit is configured for 2 wire switched operation. This simulated PSTN emulates the time delays caused by network switching equipment. This includes dial tone delay, switching delay, on hook delay and disconnect delay.

Dial tone delay is defined for the TAS 100 Series as the time between off-hook to the application of primary dial tone. It does not apply to secondary dial tone. Routing or switching delay is defined as the time between dial completion (last dial character received) and the application of secondary dial tone, ringback/ringing or busy.

On hook delay is defined as the time between the station device making an on-hook transition and the recognition of on-hook by the TAS 100 Series. Upon recognition of on-hook the TAS 100 Series will disconnect a call or signaling from the station interface. Disconnect delay starts after the on-hook delay expires.

The TAS 100 Series supports dial pulse signaling. Because a break interval is a momentary on-hook condition, caution must be taken in selecting the on hook delay. A delay time that is less than the break interval of the dial pulsing device would cause the TAS 100 Series to interpret the break interval as a disconnect and not as a dial pulse.

Disconnect delay is defined as the time from the completion of the on hook delay to the transmission of the disconnect signal. The disconnect signal is sent to the station that remains off hook after a call is terminated in 2 wire switched mode.

Disconnect Signal

The disconnect signal alerts the station that remains off hook following a terminated connection that the other station has gone on hook. It serves as feedback to the station that receives the signal, that it is no longer connected to the other party.

The disconnect signal can be defined to be dial tone, busy tone or none (silence). It is transmitted after the disconnect delay to the station that remains off hook after a call is terminated in 2 wire switched mode.

3.5.7. Forced Signaling

The TAS 100 Series allows the user to manually send (force) signaling to either station A or station B. Activation of this feature disables all the automatic signaling features of the 2-wire switched configuration independent of hook-status. The selected signaling is forced to the indicated station until a different signal is selected or the feature is disabled. In 2-wire configurations ringing/ringback, primary dial tone, or busy, may be forced to either station. In 4-wire configuration ringing/ringback, or busy, may be forced to either station. Only one forced signaling selection will be active at a given time.

Caution should be taken when using this feature to force ringing. The automatic ring trip function of the TAS 100 Series is disabled when ringing is forced. This means that the high voltage ringing signal will continue to be applied to tip (pin 5) and ring (pin 4) after the telephone or modem has gone off-hook (answered). Ringing will continue ("ringing in the ear") until a different type of signaling is forced or manual signaling is disabled.

Forced signaling can only be operated with remote control commands.

3.5.8. Dialing Analysis Features

The TAS 100 Series provides analysis of DTMF (touch-tones) and dial pulse signaling when configured for 2 wire switched configuration. DTMF and dial pulse digits from the station that has dialing priority are decoded, compared against the expected telephone number (programmed station number) and saved for readback.

Dial Pulse Make/Break Detection Intervals

Dial pulsing sends dialing information by generating momentary changes in hook status between an off-hook and on-hook condition. The on-hook interval is referred to as the "break" interval and the off-hook as the "make" interval. The number of make/break intervals corresponds to the value of the digit that is being dialed. For example, dialing a "4" creates four make/break intervals. A typical break interval is approximately 60 msec in length, while a make is typically around 40 msec.

The TAS 100 Series decodes dial pulses by measuring the length of the make/break intervals. The measured interval is then compare against a user programmed qualification window. This window specifies a minimum and a maximum time limit. Make and break intervals that exceed these limits are

ignored. The following example illustrates a situation in which the limits are exceeded.

In this example the minimum make qualification time is 25 msec and the maximum is 55 msec. The minimum break qualification time is 45 msec and the maximum is 75 msec. A modem attempts to dial a "5". Four of the break intervals dialed are 60 msec in length but one is 43 msec. In this situation the TAS 100 Series would interpret the digit as a "4" instead of a "5".

Dial pulses are typically generated by a telephone or modem at a rate of 10 pulses per second (pps). This corresponds to a combined break and make period of 100 msec (60 msec + 40 msec). However some devices dial at rates up to 20 pps (1/20 pps = 50 msec). Dial pulses at this rate would require small minima. Selecting a minimum break and make detection interval of 10 msec and a maximum break and make of 90 msec will support most available rates. See section 3.5.9.

Readback of Dialed Telephone Numbers

Dial pulse and DTMF dialing information that is received from the station that has dialing priority are decoded, compared against the expected telephone number (programmed station number) and saved for readback. The maximum quantity of dialed digits that will be saved for readback is equal to the quantity of digits in the called station's telephone number. Digits that are received in excess of this quantity are ignored.

Dialed digits that are received by the TAS when Station A is originating the call can be readback. The Station A readback buffer is cleared upon an on-hook to off-hook transition of the station. Dialed digits that are received by the TAS 100 Series when Station B is originating the call can also be readback. The Station B readback buffer is cleared upon a on-hook to off-hook transition of the station.

This page intentionally left blank.

4.0. REMOTE OPERATION

4.1. Overview

A computer or terminal can control the TAS 100 Series by issuing commands to the TAS Series' GPIB or RS-232 remote control port. The TAS 100 Series supports three control link protocols:

- RS-232 CR/LF
- RS-232 ACK/NAK
- GPIB (IEEE 488)

CR/LF (carriage return/line feed) is a simple command-line protocol, and allows you to control the TAS 100 Series from a dumb terminal or a computer. In addition to being easiest to implement, the CR/LF protocol provides a convenient way to practice using the TAS 100 Series command set.

ACK/NAK is a more sophisticated serial control protocol that includes error-checking and command retransmission.

GPIB (General Purpose Interface Bus) is the industry-standard, IEEE 488 parallel-bus instrument control protocol.

You can use the TAS 100's remote control features to design computer-controlled automatic test procedures for data communications equipment, or to access and control a TAS 100 Series unit at a remote location via a modem link.

Figure 4-1 shows the TAS 100 Series being used in an automatic modem test system. In this configuration, a computer controls the TAS 100 Series, a TAS Gemini Dual Terminal Emulator, a TAS Modem Test Switch, and other test equipment via the GPIB. The control bus originates at the computer and is connected to each piece of the test equipment. This type of configuration is simple to set up and operate, provided that the computer has GPIB controller capability.

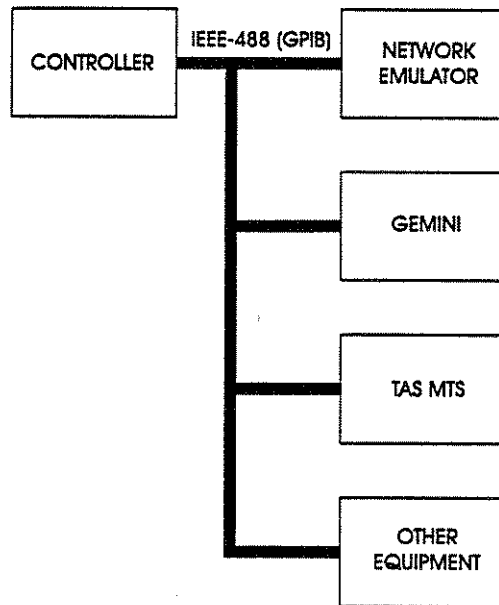

Figure 4-1. GPIB Automatic Modem Test System

Figure 4-2 shows a typical RS-232 control application. This type of setup might be used when the TAS 100 Series is the only instrument to be controlled, or when a GPIB control computer is not available.

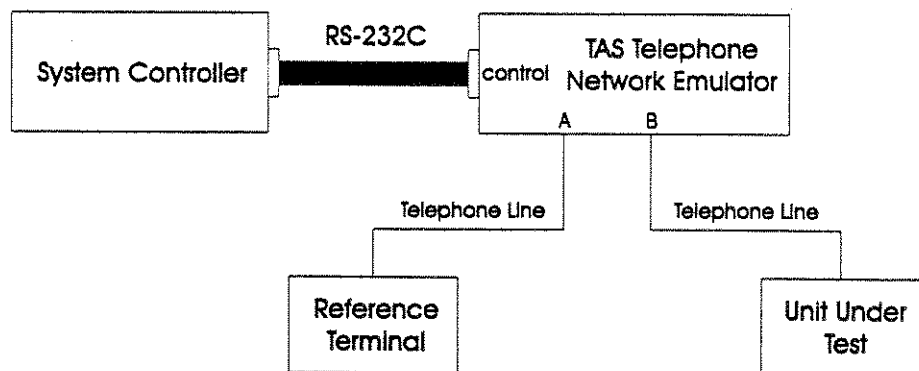

Figure 4-2. RS-232 Control

4.2. Remote Control Features

The command structure used to control the TAS 100 Series is independent of the control mode or protocol. A typical command for the TAS 100 Series would contain a function (group) id followed by one or more parameter ids with their associated data.

The TAS 100 Series supports "parameter readback" of any user programmable parameter. This feature allows the user to poll the TAS 100 Series to determine the setting of any parameter.

Refer to the command reference section for detailed information on the protocols, command structure, and specific commands.

4.3. Configuring the TAS 100 Series for Remote Control

Before you can control the TAS 100 Series from a remote terminal or computer, you must first set the remote control configuration. The remote configuration can be set only via the TAS 100 Series front panel. To set the remote control configuration, you must perform the procedures described in the following sections for the desired remote control protocol.

4.3.1. IEEE-488 Configuration

System Configuration Menu			
STATUS:	<i>okay</i>		
SYSTEM MODEL:	<i>TAS 182</i>	SW VER	<i>4.10</i>
IMPAIRMENT CONTROL:	<i>independent</i>		
REMOTE PROTOCOL:	<i>ieee 488</i>		
RS232:RATE:	<i>9600</i>	CHAR	<i>7</i> STOP <i>1.0</i>
RS232: PARITY	<i>odd</i>	ADDRESS	<i>1</i>
IEEE 488:ADDRESS	<i>1</i>		
IMD OPTION:	<i>Standard (TAS 1010)</i>		

Figure 4-3. IEEE-488 Configuration Menu

1. Select the System Configuration menu by pressing the System Configuration key as shown in figure 4-3.
2. Use the menu navigation ↓ key to scroll to the REMOTE PROTOCOL menu line.
3. Select “ieee 488” as the remote protocol by using the value + or - keys.
4. Use the menu navigation ↓ key to scroll to the IEEE 488:ADDRESS menu line.
5. Select the appropriate primary address for the TAS 100 Series by using the value + or - keys. This address would be used as the primary address of the device (TAS 100) known to the GPIB controller.
6. Put the unit into remote control mode by pressing the Remote key. The unit is now ready for IEEE 488 GPIB remote communication (see section 4.4.3 for more information on IEEE 488 GPIB protocol).

4.3.2. RS-232C CR/LF Configuration

System Configuration Menu				
STATUS:	<i>okay</i>			
SYSTEM MODEL:	<i>TAS 100</i>	SW VER	<i>4.10</i>	
IMPAIRMENT CONTROL:	<i>independent</i>			
REMOTE PROTOCOL:	<i>rs232 lf/cr</i>			
RS232:RATE	<i>9600</i>	CHAR	<i>7</i>	STOP <i>1.0</i>
RS232:PARITY	<i>odd</i>	ADDRESS	<i>1</i>	
IEEE 488:ADDRESS	<i>1</i>			
IMD OPTION:	<i>Standard (TAS 1010)</i>			

Figure 4-4. RS-232C CR/LF Configuration Menu

1. Select the System Configuration menu by pressing the System Configuration key as shown in figure 4-4.
2. Use the menu navigation ↓ key to scroll to the REMOTE PROTOCOL menu line.
3. Select “rs232 lf/cr” as the remote protocol by using the value + or - keys.
4. Use the menu navigation ↓ key to scroll to the first RS232: menu line. This menu line consists of the RATE (Bit Rate), CHAR (Number of Characters), and STOP (Number of Stop Bits) parameters for the RS232 protocol.
5. Select the appropriate bit rate, number of characters, and number of stop bits for the TAS 100 Series by using the value + or - keys. Use the menu navigation ← and → keys to move from parameter to parameter.
6. Use the menu navigation ↓ key to scroll to the second RS232: menu line. This menu line consists of the PARITY, and the ADDRESS of the RS232 protocol. The ADDRESS parameter is valid only for the RS232 ACK/NAK protocol, see section 4.4.2 for more details.
7. Select the appropriate parity by using the value + or - keys.
8. Put the unit into remote control mode by pressing the Remote key. The unit is now ready for RS-232C CR/LF remote communication (see section 4.4.1 for more information on the RS-232C CR/LF protocol).

4.3.3. RS-232C ACK/NAK Configuration

System Configuration Menu			
STATUS:	<i>okay</i>		
SYSTEM MODEL:	<i>TAS 100</i>	SW VER	<i>4.10</i>
IMPAIRMENT CONTROL:	<i>independent</i>		
REMOTE PROTOCOL:	<i>rs232 ack/nak</i>		
RS232:RATE	<i>9600</i>	CHAR	<i>7</i> STOP <i>1.0</i>
RS232:PARITY	<i>odd</i>	ADDRESS	<i>1</i>
IEEE 488:ADDRESS	<i>1</i>		
IMD OPTION:	<i>Standard (TAS 1010)</i>		

Figure 4-5. RS-232C ACK/NAK Configuration Menu

1. Select the System Configuration menu by pressing the System Configuration key as shown in figure 4-5.
2. Use the menu navigation ↓ key to scroll to the REMOTE PROTOCOL menu line.
3. Select “rs232 ack/nak” as the remote protocol by using the value + or - keys.
4. Use the menu navigation ↓ key to scroll to the first RS232: menu line. This menu line consists of the RATE (Bit Rate), CHAR (Number of Characters), and STOP (Number of Stop Bits) parameters for the RS232 protocol.
5. Select the appropriate bit rate, number of characters, and number of stop bits for the TAS 100 Series by using the value + or - keys. Use the menu navigation ← and → keys to move from parameter to parameter.
6. Use the menu navigation ↓ key to scroll to the second RS232: menu line. This menu line consists of the PARITY, and the ADDRESS of the RS232 protocol.
7. Select the appropriate parity and address by using the value + or - keys. Use the menu navigation ← and → key to move between the two parameters.
8. Put the unit into remote control mode by pressing the Remote key. The unit is now ready for RS-232C ACK/NAK remote communication (see section 4.4.2 for more information on the RS-232C ACK/NAK protocol).

4.4. TAS 100 Series Command Protocol

The TAS 100 Series command protocol provides the means for a host computer to control the TAS 100. The command protocol defines a set of simple, readable, high-level commands for TAS 100 Series control. For example, the system controller turns on the white noise source at 62.0 dBm by sending the command:

```
/RN, L620, S1/
```

And the TAS 100 Series responds:

```
/C/
```

to indicate successful execution of the command.

This section describes the command types and command message format (or command syntax) necessary for the TAS 100 to understand the command, and the responses returned from the TAS 100. The section on special commands is to help the user understand special features particular to the TAS 100 Series that are not part of the Network Simulation.

4.4.1. Command Types

The TAS 100 Series command protocol supports 3 types of command messages: execute, report, and set.

Execute commands are accepted by the TAS 100, the assigned task is completed, and then a command completed response (*/C/*) is returned. Examples of execute commands are: System self diagnostic command (*/IO,C/*) which calibrates and resets the TAS 100 Series, and Automatic Gain Control (AGC) commands (*/IO,A0/*) which performs the AGC function and then returns control to the user.

Report commands are accepted by the TAS 100 Series, then the correct parameter values are retrieved or measured and returned to the user for review. Report commands do not contain data parameters, but they can contain identifiers to define a subset of the TAS 100 Series. Examples of report commands are: System Administration Report command (*/AD,R/*) which responds with the TAS 100 Series system information, Echo Attenuator Readback command (*/EC,LI/*) which responds with the associated attenuator level setting, and System Administration Version command (*/AD,Vvv/*) which uses an identifier to respond with the correct module version number.

Set commands contain parameter values which will be stored within the TAS 100 Series (internal TAS 100 Series parameters). These parameter values configure the state of a TAS 100 Series feature to create the desired network configurations. The majority of user commands are Set commands. Examples of set commands

are: Input and Output Level commands (/IO,I-115,L0/) which sets the input and output signal level, and Gain and Delay Characteristic commands (/GD,V9/) which sets the gain and delay shape for the impairments generator.

If the TAS 100 Series is unable to complete any command, an error message will be returned to the user regardless of the command type.

4.4.2. Command Message Format

Figure 4-6 provides an exploded view of a TAS 100 Series command frame message.

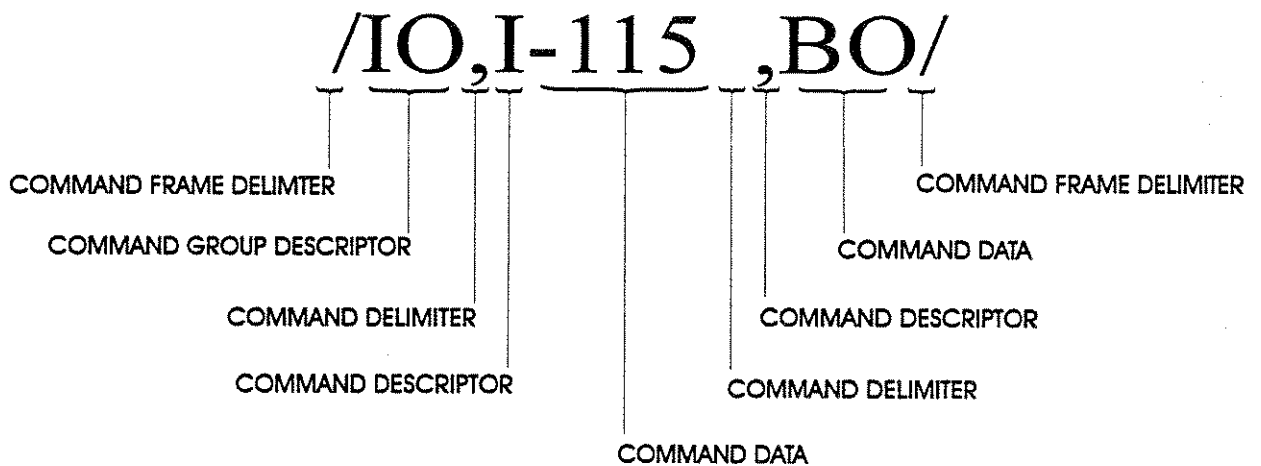

Figure 4-6. Command Frame Format

The slashes (/) in the command message are the command frame delimiters. Command frames may be concatenated, subject to a maximum of 128 characters per message. A command message ends with a carriage return (i.e. ENTER).

The alphanumeric characters after the first command frame delimiter are the command group descriptors. The command group descriptors are usually 2 or 4 alphanumeric characters in length. The commas (,) are command delimiters and define where one command or command group stops and another command starts. commands may be concatenated within a command group and may appear in any order within a command frame.

The IO in Figure 4-6 is the command group, and the I and B in Figure 4-6 are command descriptors. The alphanumeric characters following each command descriptor constitute the command parameter value (i.e. data). The number of the alphanumeric characters in the command parameter field is determined by the format of the command (see section 5.2 command descriptions for more information).

4.4.3. Response Formats

Completion Message

The TAS 100 Series provides a command completed response message to indicate the successful completion of an Execute or Set command message. The syntax of this message is:

```
/C/
```

The TAS 100 Series provides only one such response for each command message, even if the command message consists of concatenated command frames. All Commands must be completed successfully in order for the successful completion command message to be returned to the User. Error response messages have priority over successful completion messages.

Report Response Message

The TAS 100 Series provides a Report response message unique to each Report Command. Since the TAS 100 Series only returns one message to the User, only the first Report Command will be returned to the User and the remaining Report Commands will be executed but will not return their responses. If a Report Command is concatenated with Execute or Set Commands, the Report Command will return the message to the user and the successful completion message will not be sent to the user. Error response messages have priority over successful report commands.

Error Message

The TAS 100 Series returns an error message whenever it encounters an error condition while processing a command message. For example:

```
/IO, E001/
```

This message indicates the TAS 100 Series encountered an error condition while processing the Impairments Generator I/O command. The three digits which follow the E are the error number. See the Section 6.0 for an explanation of the error values returned.

The TAS 100 Series executes a command message sequentially. When the TAS 100 Series encounters an error condition, it stops processing the command message, and provides the appropriate error message. The TAS 100 Series executes all command groups and commands up to the point of error. The unit does not execute commands or command groups which are beyond the point of error.

4.4.4. Special Commands

The TAS 100 Series command protocol defines 2 special commands. These messages represent slight departures from the normal rules for processing TAS 100 Series commands.

System Administration Report Command

The first special command is the System Administration Report command: /AD,R/. This command causes the TAS 100 Series to report software version, power-up diagnostic status, and model number. The normal TAS 100 Series response to this command is:

```
/AD,Vvvv,Rrrr,Mmmmm/
```

When this command is executed from the system controller, it is executed like any other report command; however, the TAS 100 Series automatically prepares the system administration response message whenever it is reset. The TAS 100 Series provides this reset message in response to the next poll (or next inquiry in CR/LF protocol). The TAS 100 Series will not accept new commands until the system controller polls for this message. Information contained in the response indicates the TAS 100 Series version number, error status, and model number.

Parameter Value Readback

Command Format

The readback of parameter values is associated with any command used to set a parameter value. There are two types of commands that are used to set parameter values: those that only include a parameter value, and those that include additional information, such as station A or B. The information that is returned may be dependent upon the System Administration impairment generator selection command (/AD,Ii/) for those commands that require setting the impairments generator. If Ii = 1 or 3, generator 1 is selected for readback, and if Ii = 2, then generator 2 is selected for readback. The following list contains all command groups with commands that have a readback capability:

- AD - C,F,G,I,M,V
- AJ - F,L,S
- EC - Lj,Pj,Sj
- FS - F,S
- GD - V,W,Y
- IM - I,L,S
- IO - B,I,L
- LC - Bj,D,Fj,M,Xj,Yj

- NL - C,M,Q,S
- PC - C,L,P,R,S
- PJ - F,L,S
- RN - L,S,W
- SD - D,S
- SF - F,L,S
- SG - Bj,Cj,D,E,Fj,Hj,I,K,L,Pj,Rj,Tj,Y
- SW - M,N,Q,Tj

The following examples illustrate the readback capability for several typical commands.

/AD,I/ - this command reads back the selection of the impairments generator, regardless of whether generator 1, generator 2, or both generators are selected for programming or readback.

/EC,LC/ - this command reads back the level setting of the station B near end echo attenuator. The C associated with the command L selects the particular echo attenuator.

/GD,V/ - this command reads back the identification number for a particular gain/delay shape. The value returned is dependent upon the last programming or readback direction selection command (*/AD,I1/*, */AD,I2/*, or */AD,I3/*). If I3 was the command sent, then generator 1 is selected for readback.

/SG,FA/ - this command reads back the frequency of dial tone frequency 1. The A associated with the command F selects the particular type of tone and whether the frequency is 1 or 2.

Response Format

The response format is intended to return information for the selected command group and command. The following examples illustrate possible responses for the four commands noted in the previous command paragraphs.

/AD,I2/ - impairments generator 2 is selected for programming or readback.

/EC,LC200/ - the station B near end echo attenuator is set to a level of 20.0 dB attenuation.

/GD,V06/ - the gain/delay shape for generator 2 is set to CCITT M1020.

/SG,FA4800/ - the network signal dial tone frequency 1 is set to 480.0 Hz.

4.5. Transmission Layer Protocols

This section describes the 3 Transmission Layer Protocols available to communicate with the TAS 100: GPIB, RS-232C CR/LF and RS-232C ACK/NAK. These protocols define the control characters and sequence of events which allow a message to be sent to and from the TAS 100. The TAS 100 Series user command (See Command Reference section) is contained within these control characters. All Protocols provide a TAS 100 Series response for every system controller command to the TAS 100. The TAS 100 Series does not process a new command from the system controller until it completes the processing of a pending command.

In order to activate a specific protocol, the system must be configured for that specific protocol. See Section 4.2 "Configuring the TAS 100 Series for Remote Control" for further details on setting up the remote protocol.

4.5.1. RS-232C CR/LF Protocol

The TAS 100 Series Carriage Return/Line Feed (CR/LF) protocol allows simple, dumb terminal control of the TAS 100.

To enter a command at the terminal, simply type the command in response to the ">" prompt, followed by <RETURN> (i.e. "CR", Carriage Return or Enter). The TAS 100 Series executes the command and sends the response back to the terminal as a series of ASCII characters.

Polling for a Response

The TAS 100 Series automatically provides a response whenever it receives a command from the terminal. It also automatically provides the system administration message whenever it is powered on or reset. In the CR/LF protocol, the terminal or controller does not have to explicitly poll for a TAS 100 Series response.

Sending Commands to the TAS 100 Series

To send a command to the TAS 100 Series, simply type the command, followed by <RETURN>.

Receiving Responses from the TAS 100 Series

The TAS 100 Series automatically provides a response for every command. Some commands, such as MEASURE and AGC, take several seconds to complete. The TAS 100 Series sends the response to such commands back to the terminal after it has completed processing the command.

4.5.2. TAS 100 Series ACK/NAK Protocol

The TAS 100 Series ACK/NAK protocol supports RS-232C multipoint communication between a system controller and one or more TAS 100 Series units. The controller initiates all transactions. To communicate with a TAS 100 Series, the system controller must perform the following steps:

1. Poll the TAS 100 Series for pending response or system reset message.
2. Send the message, with address, control characters, and block checksum, to the TAS 100 Series.
3. Poll the TAS 100 Series for the command response.

The following is an example of a system controller-TAS 100 Series command transaction.

Controller polls for pending response:

[a1] [a0] p <ENQ>

TAS 100 Series responds:

[a1] [a0] <EOT>

Controller sends command:

[a1] [a0] s <ENQ> <SOH> <STX> command <ETX> [b2] [b1]
[b0]

TAS 100 Series responds:

[a1] [a0] <ACK>

Controller polls for response:

[a1] [a0] p <ENQ>

TAS 100 Series responds:

[a1] [a0] <SOH> <STX> response <ETX> [b2] [b1] [b0]

NOTE: Spaces in the previous examples are for clarity only. There are no spaces between command fields. The [ax] and [bx] fields are the address and block checksum fields, respectively. The “<” denote ASCII control characters. The “p” indicates a poll message, and the “s” indicates a select message. The block check field is the two’s complement of the checksum of all characters from the first address character through the <ETX> character. This sum is represented in three ASCII-decimal digits. For example, if the checksum is 201, then the block checksum should be 055 (256 - 201).

Polling for a Response

When the TAS 100 Series receives a command from the controller, it executes the command and prepares a response. The controller must poll the TAS 100 Series to receive this response. The poll sequence is:

```
[a1] [a0] p <ENQ>
```

The controller must pad the address field on the left with a space (hex 20) if the address is less than 10 (i.e. single digit address). The controller should be prepared to handle one of three possible results.

1. No response.

2. No message:

```
[a1] [a0] <EOT>
```

3. Response:

```
a1] [a0] <SOH> <STX> response <ETX> [b2] [b1] [b0]
```

The TAS 100 Series does not respond to a poll if it is configured illegally, if it detects an error in the poll message, or if it is not turned on. If the system controller does not receive a response from the TAS 100 Series, it should poll again.

The TAS 100 Series gives a no message response if it has no response pending.

Sending Commands to the TAS 100 Series

To send a command to the TAS 100 Series, the system controller must form a string which consists of the TAS 100 Series address, the select character "s", the ASCII control characters, the command, and a block checksum, as follows:

```
[a1] [a0] s <ENQ> <SOH> <STX> command <ETX> [b2] [b1]
[b0]
```

The system controller must be prepared to handle one of three possible results:

1. No response.

2. Negative acknowledge:

```
[a1] [a0] <NAK>
```

3. Positive acknowledge:

```
[a1] [a0] <ACK>
```

The TAS 100 Series does not respond to the command if it is not addressed properly, if it is off, or if it detects an error in the command message control characters.

The TAS 100 Series responds with a negative acknowledgment (NAK) if it detects a transmission error in the command message (bad block sum), or if the command message is too long (greater than 128 characters). In this case, the controller should send the command message again.

The block sum is represented in ASCII-decimal on the control link, and is the two's complement of the module 256 sum of all the characters in the message, up to and including the <ETX> control character.

The TAS 100 Series returns a positive acknowledgment (ACK) when it detects no message transmission errors.

Receiving Responses from the TAS 100 Series

The TAS 100 Series provides a command response when it is polled by the system controller. If the system controller detects a transmission error in the TAS 100 Series response, it should poll the TAS 100 Series, send the message again, and poll again for the response.

4.5.3. TAS 100 Series GPIB Protocol

The TAS 100 Series GPIB protocol supports a bus communication architecture in which the TAS 100 Series Telephone Network Emulator is one of the devices being controlled. The system controller initiates all transactions. To communicate with the TAS 100 Series, a GPIB system controller must perform the following steps:

1. Poll the TAS 100 Series for a pending response or the system reset message.
2. Send the message to the TAS 100 Series.
3. Poll the TAS 100 Series for the command response.

The system controller must meet all GPIB electrical and mechanical specifications.

The IEEE 488-1978 standard defines the GPIB interface functions and the subsets of those functions. The TAS 100 Series implements the subset indicated Table 4-1.

FUNCTION	DESCRIPTION	TAS 100 SERIES
SH1	source handshake	full capability
AH1	acceptor handshake	full capability
T6	talker function	basic talker, serial poll unaddress if My Listen Address (MLA) is received
TEO	extended talker	no capability
L4	listener function	basic listener, unaddress if My Talk Address (MTA) is received
LEO	extended listener	no capability
SR1	service request	full capability
RLO	remote-local	no capability- TAS 100 Series is always in remote mode
PPO	parallel poll	no capability
DCO	device clear	no capability
DTO	device trigger	no capability
CO	controller	no capability

Table 4-1. GPIB Subsets

The TAS 100 Series provides a GPIB status byte to indicate its current state. The TAS 100 Series states are:

1. Idle - 02H.
2. Busy - 01H.
3. Ready To Respond (RTR) - 04H or 44H.

Idle

This state indicates that the TAS 100 Series does not have a message to send and is ready to accept a command.

Busy

This state indicates that the TAS 100 Series is currently processing a command. The TAS 100 Series does not accept new commands until it has finished processing the current command and has provided the response to the controller.

Ready To Respond (RTR)

This state indicates that the TAS 100 Series currently has a message to send to the controller. The TAS 100 Series is always READY TO RESPOND when power is first applied, when it is reset, or when it has finished processing a command. When the TAS 100 Series is ready to respond, it activates the service request line (SRQ), and the RTR status = 44H. After the controller conducts the serial poll, SRQ goes inactive, and the RTR status equals 04H. Figure 4-7 shows a flowchart for a typical bus controller sequence.

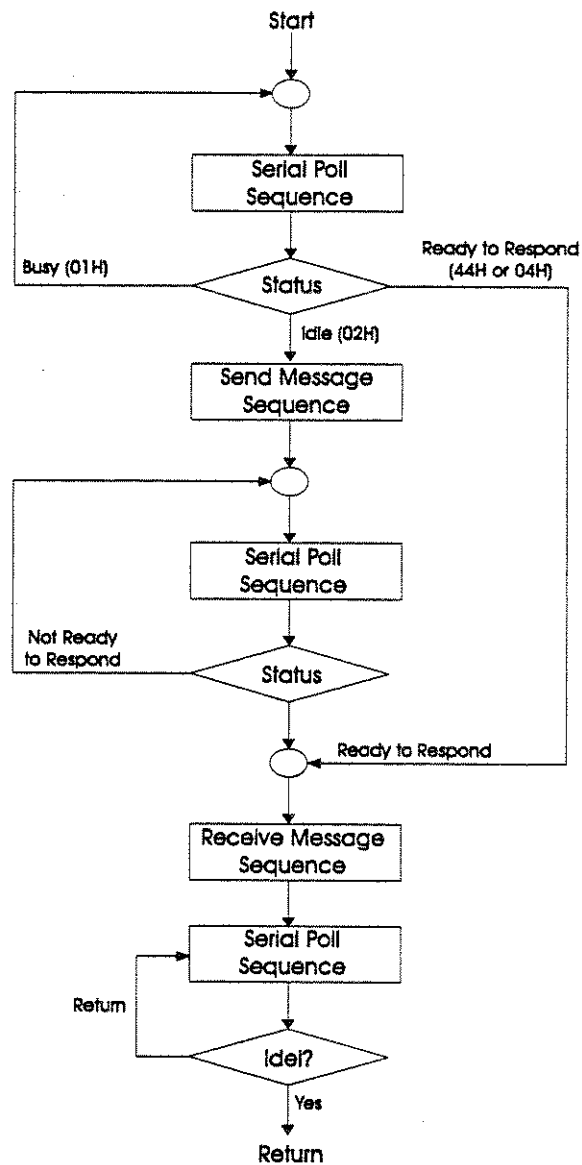

Figure 4-7. GPIB (IEEE-488) Bus Controller Sequence

Polling for a Response

The following list contains typical bus events required to effect a serial poll of the TAS 100 Series. The actual bus sequence may be different:

1. ATN active
2. UNT - (UNTalk)
3. UNL - (UNListen)
4. SPE - (Serial Poll Enable)
5. MTA - (TAS 100 Series My Talk Address)
6. System controller programmed to listen
7. ATN inactive
8. TAS 100 Series sends status
9. ATN active
10. SPD - (Serial Poll Disable)
11. UNT - (UNTalk)

Always conduct a serial poll before sending a command to the TAS 100 Series. If the TAS 100 Series has a pending message to send, it does not accept a new command.

Sending Commands to the TAS 100 Series

The following list contains typical bus events required to send a command to the TAS 100 Series. Your actual bus sequence may be different:

1. ATN active
2. UNT - (UNTalk)
3. UNL - (UNListen)
4. MLA - (TAS 100 Series My Listen Address)
5. System controller programmed to talk
6. ATN inactive
7. System controller sends command to TAS 100 Series, and asserts EOI with last command character
8. ATN active
9. UNL - (UNListen)

Command strings must not be terminated with <CR> or <CR><LF>. The system controller signals the end of a command string by asserting EOI (end of interrupt) while it sends the last character of the command.

Some commands require several seconds of the TAS 100 Series processing time. While most commands complete in less than 100 msec, commands such as AGC, MEASURE, and CALIBRATE may require up to 50 seconds. The system controller should conduct serial polls until it detects that the TAS 100 Series status equals RTR.

Receiving Responses from the TAS 100 Series

The following is a list of typical bus events required to receive a response from the TAS 100 Series. Your actual bus sequence may be different:

1. ATN active
2. UNT - (UNTalk)
3. UNL - (UNListen)
4. MTA - (TAS 100 Series My Talk Address)
5. System controller programmed to listen
6. ATN inactive
7. TAS 100 Series sends data to system controller
8. System controller re-asserts control when EOI goes active
9. ATN active
10. UNT - (UNTalk)

The TAS 100 Series does not terminate its response message with a <CR> or <CR><LF>. The unit signals the end of a response message by raising EOI while it sends the last character of the response.

4.6. Programming Sequence

The TAS 100 Series contains two major subsystems: the Central Office (CO) Simulator and the Transmission Channel Simulator. The Central Office Simulator implements telephone network configuration and central office functions, and the Transmission Channel Simulator generates telephone network trunk impairments. A controller should configure each of these subsystems before executing a test. A typical programming sequence is detailed below:

1. Set Network Configuration (4W private, 2W private, 2W autoswitched, or 2W switched).
2. Set CO network simulator switching parameters.
3. Set CO network simulator signaling parameters.
4. Set transmission channel input/output configuration.
5. Set transmission channel impairment parameters.
6. Execute test.

4.6.1. Transmission Channel Impairment Parameters

All models except the 150 of the TAS 100 Series provides programmable channel impairments, such as noise, gain distortion, envelope delay distortion, etc. These impairments can be controlled by issuing commands from a control computer to one of the TAS 100 Series control interfaces (RS-232C or GPIB). The control program must assign a value to each impairment parameter for every impairment function activated or the TAS 100 Series will retain the value previously set. To turn the impairments on and set their parameter values, see section 5.2 on Command Descriptions.

4.6.2. Central Office Parameters

The Central Office (CO) simulator module simulates network configuration and central office functions. If the system controller specifies 4-wire private line operation, the CO simulator provides a dedicated, 600 ohm, 4-wire circuit. If the system controller specifies switched operation, the CO simulator provides two switched-network stations with adjustable central office parameters. Once the switched-network parameters are set, the controller does not have to interact with the TAS 100 Series. The CO simulator module handles the call processing and signaling functions.

Line Control

The LC command controls the CO simulator line configuration. The system controller should invoke this command as a first step toward controlling the TAS

100 Series to ensure proper line setup. The LC command allows you to specify the Network Configuration (2W or 4W). See section 5.2.8 for more information on the LC command.

Switching

The SW command controls network switching parameters, such as telephone numbers and switching delay time. See section 5.2.17 for more information on the SW command.

Signaling

The SG command controls central office signaling parameters, and allows the system controller to interrogate line status. Signaling is usually generated automatically during call processing, but the system controller may also force signaling manually. The S subframe selects and sends a signal to the designated station. This command option may be used to determine the ability of the device-under-test to detect signaling. This command option should not be used under normal circumstances, since it disables the signaling associated with automatic call processing.

The Z subframe directs the TAS 100 Series to report the status of the designated station. For example, the system controller can invoke this command to verify that a station goes off-hook after it receives ringing. See section 5.2.16 for more information on the SG command.

This page intentionally left blank.

5.0. COMMAND REFERENCE

5.1. Overview

This chapter provides a complete description of each command group and all commands within each group.

You should be thoroughly familiar with Chapter 4.0, "Remote Operation", of this manual before you attempt to use TAS 100 Series remote commands.

Some of the sections or items in this chapter apply only to certain model(s) of the TAS 100 family. The notation [*model, ...*] indicates that the section or item only applies to the model(s) listed inside the brackets. Otherwise, the section applies to all TAS 100 family models.

5.2. TAS 100 Series Network Emulator Commands for Software Version 4.20

TAS 100 Series network emulator commands and command responses allow you to completely control network simulator operation. The commands are the same if you control the network simulator by the RS-232C Carriage Return/Line Feed protocol, the RS-232C ACK/NAK protocol, or the GPIB (IEEE 488) protocol.

5.2.1. Conventions to Specify Commands

When programming the TAS 100 Series from the commands listed within this manual, several conventions must be observed:

Commands must start and end with a '/'.

Commas (',') are necessary between command groups and commands, and between commands.

Examples of valid commands:

/AD,C28/

/FS,S1,F1000/

/LC,BB1,YA0/.

Decimal points are not accepted.

5.2.2. Command Summary

System Administration AD

NAME	DESCRIPTION	DATA RANGE	EXAMPLE	SECTION
Ccc	Configuration File Recall	0 to 51	/AD,C28/	5.3.1.
Ff	File Recall Scope	0 - full, 1 - CO only	/AD,F0/	5.3.1.
Gg	IMD Mode [181, 182]	0-Standard, 1-Proprietary	/AD,G0/	5.3.1.
Ii	Imp. Generator Control	1 to 3	/AD,I2/	5.3.1.
J	Imp. Generator Control Query	None	/AD,J/	5.3.1.
Mmm	Signal Monitor	0 to 15	/AD,M8/	5.3.1.
R	Report Status	None	/AD,R/	5.3.1.
Sss	Save Configuration	0 to 4	/AD,S3/	5.3.1.
Vvv	Volume Control	0 (off) to 15 (maximum)	/AD,V0/	5.3.1.
Xx	Software Version Query	0-CO, 1-IMP1, 2-IMP2	/AD,X1/	5.3.1.
Z	Central Office Clear	None	/AD,Z/	5.3.1.

Amplitude Jitter AJ [182]

NAME	DESCRIPTION	DATA RANGE	EXAMPLE	SECTION
Fffff	Amplitude Jitter Frequency	0 to 30000 (0.00 to 300.00Hz)	/AJ,F6000/	5.3.2.
Llll	Amplitude Jitter Level	0 to 980 (0.0 to 98.0%)	/AJ,L155/	5.3.2.
Ss	Amplitude Jitter Switch	0 - disable, 1 - enable	/AJ,S0/	5.3.2.

Echo Control EC

NAME	DESCRIPTION	DATA RANGE	EXAMPLE	SECTION
Lj<+/->lll	Echo Attenuation Level	j A, B, C, or D ll -100 to 400 for j=A or C (-10.0 to 40.0 dB) lll-200 to 300 for j=B or D (-20.0 to 30.0 dB)	/EC,LB153/	5.3.3.
Pjp	Echo Attenuator Polarity	j A, B, C, or D p0-positive, 1-negative	/EC,PC1/	5.3.3.
Sjs	Echo Attenuator Switch	j A or B s 0-disable 1-enable	/EC,SB1/	5.3.3.

Frequency Shift FS [181, 182]

NAME	DESCRIPTION	DATA RANGE	EXAMPLE	SECTION
F<+/->ffff	Frequency Shift Level	-1975 to 1975 (Hz)	/FS,F1025/	5.3.4.
Ss	Frequency Shift Switch	0 - disable, 1 - enable	/FS,S1/	5.3.4.

Gain / Delay GD [151, 152, 181, 182]

NAME	DESCRIPTION	DATA RANGE	EXAMPLE	SECTION
Vvv	Gain & Delay Shape	0 to 39	/GD,V9/	5.3.5.
Www	Custom Gain Filter	0 to 55	/GD,V25,W51/	5.3.5.
Yyy	Custom Gain Filter	0 to 52	/GD,V25,Y42/	5.3.5.

Gain Hits GH [181, 182]

NAME	DESCRIPTION	DATA RANGE	EXAMPLE	SECTION
Ddddd	Gain Hits Duration	1 to 20000 (msec)	/GH,D5/	5.3.6.
Iiiii	Gain Hits Interval	1 to 3200 (0.1 to 320.0 sec)	/GH,I10/	5.3.6.
L<+/->lll	Gain Hits Level	-200 to 60 (-20.0 to 6.0 dB)	/GH,L30/	5.3.6.
Rrrrr	Gain Hits Risetime	2 to 9900 (2 to 990.0 msec)	/GH,R2/	5.3.6.
Ss	Gain Hits Switch	0 - disable, 1 - enable	/GH,S1/	5.3.6.

Impulse Noise IM [181, 182]

NAME	DESCRIPTION	DATA RANGE	EXAMPLE	SECTION
Iiiii	Impulse Noise Interval	1 to 3200 (0.1 to 320.0 sec)	/IM,I15/	5.3.7.
Llll	Noise Level	0 to 550 (0.0 to 55.0 dB)	/IM,L205/	5.3.7.
R	Report Noise Level	None	/IM,R/	5.3.7.
Ss	Impulse Noise Switch	0 - disable, 1 - enable	/IM,S1/	5.3.7.

Impairments Generator I/O IO

NAME	DESCRIPTION	DATA RANGE	EXAMPLE	SECTION
Aa	Automatic Gain Control	0 - input AGC 1 - output AGC	/IO,A1/	5.3.8.
Bb	Bypass	0 - disable, 1 - enable	/IO,B1/	5.3.8.
C	Calibration	None	/IO,C/	5.3.8.
I<+/->iii	Input Level	-230 to 70 (-23.0 to 7.0 dBm)	/IO,I-115/	5.3.8.
L<+/->lll	Output Level	-500 to 0 (-50.0 to 0.0 dBm)	/IO,L0/	5.3.8.
Z	Clear	None	/IO,Z/	5.3.8.

Line Control LC

NAME	DESCRIPTION	DATA RANGE	EXAMPLE	SECTION
Bjb	Hybrid Balance	j A or B b 0 - internal, 1 - external	/LC,BB0/	5.3.9.
Dd	Simulation Direction [151, 181]	0 - A to B , 1 - B to A	/LC,D0/	5.3.9.
Fjf	Channel Mode	j A or B f 0 - internal, 1 - external	/LC,FB0/	5.3.9.
Mm	Network Interface Mode	0 to 5	/LC,M2/	5.3.9.
Xjx	Loopback Relay	j A or B x 0 - open, 1 - close	/LC,XB0/	5.3.9.
Yjy	Programming Resistor	j A or B y 0 - open, 1 - 866 ohm	/LC,YA1/	5.3.9.

Signal Measurements MM

NAME	DESCRIPTION	DATA RANGE	EXAMPLE	SECTION
R	Report Measurement	None	/MM,R/	5.3.10.

Nonlinear (Intermodulation) Distortion NL [181, 182]

NAME	DESCRIPTION	DATA RANGE	EXAMPLE	SECTION
Qqqq	2nd Order Distortion Level	200 to 600 (20.0 to 60.0 dB)	/NL,Q354/	5.3.11.
Cccc	3rd Order Distortion Level	200 to 600 (20.0 to 60.0 dB)	/NL,C200/	5.3.11.
Mm	Nonlinear Distortion Mode	0-expansive, 1-compressive	/NL,M1/	5.3.11.
Ss	Nonlinear Distortion Switch	0 - disable, 1 - enable	/NL,S1/	5.3.11.

Pulse-Code Modulation PC [151, 152, 181, 182]

NAME	DESCRIPTION	DATA RANGE	EXAMPLE	SECTION
Cc	PCM Coding	0 - u-law, 1 - a-law	/PC,C1/	5.3.12.
Ll*	# of PCM Links	1 to 3 links	/PC,L2/	5.3.12.
Pp*	PCM Position	0 - last, 1 - first	/PC,P0/	5.3.12.
Rr	Robbed Bit Signaling	0 - disable, 1 - enable	/PC,R1/	5.3.12.
Ss	PCM Switch	0 - disable, 1 - enable	/PC,S1/	5.3.12.

* This parameter is only available on Model 182.

Phase Hits PH [181, 182]

NAME	DESCRIPTION	DATA RANGE	EXAMPLE	SECTION
Ddddd	Phase Hits Duration	1 to 20000 (msec)	/PH,D5/	5.3.13.
Iiiii	Phase Hits Interval	1 to 3200 (0.1 to 320.0 sec)	/PH,I10/	5.3.13.
Llll	Phase Hits Level	0 to 900 (0 to 90.0 degrees)	/PH,L450/	5.3.13.
Rrrrr	Phase Hits Risetime	2 to 9900 (2 to 990.0 msec)	/PH,R2/	5.3.13.
Ss	Phase Hits Switch	0 - disable, 1 - enable	/PH,S1/	5.3.13.

Phase Jitter PJ [181, 182]

NAME	DESCRIPTION	DATA RANGE	EXAMPLE	SECTION
Fffff	Phase Jitter Frequency	0 to 30000 (0.00 to 300.00Hz)	/PJ,F6000/	5.3.14.
Llll	Phase Jitter Level	0 to 450 (0.0 to 45.0 deg)	/PJ,L155/	5.3.14.
Ss	Phase Jitter Switch	0 - disable, 1 - enable	/PJ,S0/	5.3.14.

Random (White) Noise RN [151, 152, 181, 182]

NAME	DESCRIPTION	DATA RANGE	EXAMPLE	SECTION
Llll	White Noise Output Level	200 to 900(20.0 to 90.0 dBm)	/RN,L625/	5.3.15.
Ss	White Noise Generator Switch	0 - disable, 1 - enable	/RN,S1/	5.3.15.
Ww	Noise Weighting	0 - C-message, 1 - 3k flat, or 2 - psophometric	/RN,W2/	5.3.15.

Satellite Delay SD [151, 152, 181, 182]

NAME	DESCRIPTION	DATA RANGE	EXAMPLE	SECTION
Ddddd	Delay Magnitude	0 to 12799 (0 to 1599.875 ms)	/SD,D276/	5.3.16.
Ss	Satellite Delay Switch	0 - disable, 1 - enable	/SD,S1/	5.3.16.

Single Frequency Interference (SFI) SF [182]

NAME	DESCRIPTION	DATA RANGE	EXAMPLE	SECTION
Fffff	SFI Frequency	0 to 3400 (0.00 to 3400.0Hz)	/SF,F1050/	5.3.17.
Llll	SFI Level	0 to 500 (0.0 to 50.0dB)	/SF,L200/	5.3.17.
Ss	SFI Switch	0 - disable, 1 - enable	/SF,S0/	5.3.17.

Network Signaling SG

NAME	DESCRIPTION	DATA RANGE	EXAMPLE	SECTION
Bjbbb	Busy Cadence	j A or B bbb 0 to 200 (note 1)	/SG,BA3/	5.3.18.
Cjc	Loop Current Polarity	j A or B c0-positive, 1-negative	/SG,CB1/	5.3.18.
D<+/->dd	Dial Tone Level	-40 to 0 (dBm)	/SG,D-25/	5.3.18.
Ee	Reverse Polarity Signaling	0-disable, 1-enable	/SG,E1/	5.3.18.
Fjffff	Signaling Tone Frequencies	j A to F fff 0 or 1000 to 7200 (Hz)	/SG,FD60 00/	5.3.18.
Hjhh	Independent Loop Current Level	j A or B hh 1 to 15 (8 to 120 mA)	/SG,HA3/	5.3.18.
Iii	Combined Loop Current Level	ii 1 to 15 (8 to 120 mA)	/SG,I3/	5.3.18.
Kk	Signaling Cadence Resolution	0-50ms steps, 1-25ms steps	/SG,K1/	5.3.18.
Lll	Ring Level	1 to 100 (Vrms)	/SG,K60/	5.3.18.
Mm	Busy Station	A, B, or C	/SG,MC/	5.3.18.
Pjpp	Dial Pulse Make/Break Intervals	j A to D pp 10 to 90 (ms)	/SG,PC70/	5.3.18.
Rjrrr	Ringling & Audible Ringing Cadence	j A to F rrr 0 to 200 (note 1)	/SG,RF50/	5.3.18.
Ss	Send Signal	A to G	/SG,SD/	5.3.18.
Tjttt	Dial Tone Cadence	j A to F ttt 0 to 200 (note 1)	/SG,TB50/	5.3.18.
Yyyy	Ring Frequency	140 to 750 (14.0 to 75.0 Hz)	/SG,Y420/	5.3.18.
Zz	Report Line Status	A or B	/SG,ZA/	5.3.18.

Note 1: Actual value in ms depends on the cadence resolution selected. See corresponding section and section 5.2.16.8. for more information.

Switching SW

NAME	DESCRIPTION	DATA RANGE	EXAMPLE	SECTION
Llllll	Disconnect Signal Delay	1 to 30000 (ms)	/SW,L50/	5.3.19.
Mmmmmm	Switching Delay	1 to 25000 (ms)	/SW,M50/	5.3.19.
Nnnnnn	Dial Tone Delay	2 to 25000 (ms)	/SW,N25/	5.3.19.
Qqqq	On Hook Delay	1 to 255 (ms)	/SW,Q200/	5.3.19.
Rr	Disconnect Signal Selection	0 - None, 1 - Busy tone or 2 - Dial Tone	/SW,R2/	5.3.19.
Tjt...t	Station Telephone Number	j A or B t...t 0 to 9, *, #, or + (max 15)	/SW,TA123/	5.3.19.
Zz	Report Received Number	A or B	/SW,ZB/	5.3.19.

5.3. Command Descriptions

The following is a summary of the command groups that are described in this section:

<u>Command</u>	<u>Function</u>
AD	System Administration
AJ	Amplitude Jitter
EC	Echo Control
FS	Frequency Shift
GD	Gain / Delay
GH	Gain Hits
IM	Impulse Noise
IO	Impairments Generator I/O
LC	Line Control
MM	Signal Measurements
NL	Nonlinear Distortion (Intermodulation Distortion)
PC	Pulse-Code Modulation
PH	Phase Hits
PJ	Phase Jitter
RN	Random Noise (White Noise)
SD	Satellite Delay
SF	Single Frequency Interference
SG	Network Signaling
SW	Switching

5.3.1. System Administration (AD)

Command Group Format:

/AD,Ccc,Ff,Gg,Ii,J,Mmm,R,Sss,Vvv,XX,Z/

Command Group Description:

Controls various system level administrative functions.

Configuration File Recall (Ccc)

Command Description:

Recalls the specified system configuration file.

Valid Command Data (cc):

0 - 4: user defined (file 0 - file 4)	23: Singapore
5: factory default	24: Sweden
6: USA average	25: Switzerland
7: USA worst case	26: Taiwan
8 - 13: EIA496A_L1 - EIA496A_L6	27: Germany
14: Great Britain	28 - 37: TSB37_L7 - TSB37_L16
15: Japan	38: EIA_17a
16: France	39: EIA_17b
17: Netherlands	40: EIA_17c
18: Italy	41: EIA_18a
19: Belgium	42: EIA_18b
20: Korea	43: EIA_18c
21: Canada	44 - 49: EIA_L19a - EIA_L24a
22: Norway	50 - 51: RITT1 - RITT2

NOTE: System configurations 28-51 are only available for model 182.
--

Example:

To recall the configuration file for the USA average test scenario:
/AD,C6/

Expected Response:

/C/

Remarks:

The detail configuration of these files, excluding the user defined ones, are listed in section A.2 Appendix 2.

File Recall Scope (Ff)

Command Description:

Controls the scope of the recalled system configuration file selected by the /AD,Ccc/ command parameter.

Valid Command Data (f):

- 0 - Recalls the full system configuration file, consisting of central office and impairments parameters.
- 1 - Recalls a partial system configuration file of only central office parameters.

Example:

To specify the next recall as a full system recall (both central office and impairments):

/AD,F0/

Expected Response:

/C/

Remarks:

Refer to section A.2. Appendix 2 for more information on the recall parameters.

Nonlinear Distortion Mode (Gg) [181, 182]

Command Description:

Controls the mode of operation of the nonlinear (intermodulation) distortion impairment.

Valid Command Data (g):

- 0 - Standard (TAS 1010) mode
- 1 - Proprietary mode

Example:

To set the nonlinear distortion mode to standard:

/AD,G0/

Expected Response:

/C/

Remarks:

The "Standard (TAS 1010)" selection emulates the implementation provided in the TAS 1010 family of channel simulators. For a complex transmission signal such as a modem signal, the Proprietary selection typically results in a higher level of IMD (and thus a reduced signal to total distortion ratio) than the Standard (TAS 1010) selection. However the distortion measured using the standard IEEE 4-tone technique will be the same for both selections.

Impairment Generator Control (Ii)

Command Description:

Selects Impairments Generator 1 or Impairments Generator 2 or both for programming.

Valid Command Data (i):

- 1 - Impairments Generator 1
- 2 - Impairments Generator 2
- 3 - Both

Example:

To set the impairment control to Impairments Generator 2:
/AD,I2/

Expected Response:

/C/

Impairment Generator Control Query (J)

Command Description:

Reports the current Impairments Generator selected for programming.

Valid Command Data:

None

Response Definition:

Format: /AD,Jj/.

'Jj' contains the current Impairments Generator selected for programming:

- 1 - Impairments Generator 1
- 2 - Impairments Generator 2
- 3 - Both Impairments Generators 1 and 2

Example:

/AD,J/

Expected Response:

/AD,J3/

Implies that the Impairment control is in combined mode (i.e. both Impairments Generators are selected).

Signal Monitor (Mmm)

Command Description:

Selects a signal to be monitored by the internal level meter, audio speaker and for presentation at the rear panel monitor port.

Valid Command Data (mm):

- 0: A→B Impairments Generator input
- 1: A→B Impairments Generator DSP module output
- 2: A→B Impairments Generator attenuator module output
- 3: A→B Impairments Generator noise module output
- 4: Station B receive 4-wire signal
- 5: Station A transmit signal
- 6: Station A receive 2-wire signal
- 7: Station A local echo attenuator output
- 8: B→A Impairments Generator input
- 9: B→A Impairments Generator DSP module output
- 10: B→A Impairments Generator attenuator module output
- 11: B→A Impairments Generator noise module output
- 12: Station A receive 4-wire signal
- 13: Station B transmit signal
- 14: Station B receive 2-wire signal
- 15: Station B local echo attenuator output

Example:

To monitor the B→A Impairments Generator input: /AD,M8/

Expected Response:

/C/

Report Status (R)

Command Description:

Causes TAS 100 to report software version, power-up diagnostics status, and model number. Note that this command contains no command data.

Valid Command Data:

None

Response Definition:

Format: /AD,Vvvv,Rrrr,Mmmmmm/.

'Vvvv' contains the software version number. Version is (v.vv).

'Rrrr' contains the error status as of the last power-up reset. The error status code (rrr) corresponds to the error codes listed in section 6.0. A status of 000 means that no error was detected.

'Mmmmmm' contains the model number.

Example:

/AD,R/

Expected Response:

/AD,V410,R000,M182/

Save Configuration (Sss)

Command Description:

Saves the current system configuration to the specified file number.

Valid Command Data (ss):

0 - file 0

1 - file 1

2 - file 2

3 - file 3

4 - file 4

Example:

To save the current system configuration to user defined file number 3:

/AD,S3/

Expected Response:

/C/

Volume Control (Vvv)

Command Description:

Controls the volume of the audio monitor.

Valid Command Data (vv):

'vv' determines the volume in 16 steps, where:

0 - Off

15 - Maximum volume

Example:

To turn the volume off:

/AD,V0/

Expected Response:

/C/

Software Version Query (Xx)

Command Description:

Interrogates the simulator requesting the version number of software code for central office, impairments board 1 (A→B), or impairments board 2 (B→A).

Valid Command Data (x):

0 - Requests the central office version number

1 - Requests the impairments board 1 version number

2 - Requests the impairments board 2 version number

Response Definition:

Format: /AD,Xvv/

'vv' contains the version number of the board selected.

Example:

To query the software version number of the impairment board 1:

/AD,X1/

Expected Response:

/AD,X41/

Implies that software version is 4.1 for impairment board 1.

Central Office Clear (Z)

Command Description:

Causes the central office simulator module to “clear” itself (i.e. establish the factory default parameter settings).

Valid Command Data:

None

Example:

/AD,Z/

Expected Response:

/C/

Remarks:

This command only resets the central office parameters to the factory default. The Impairments Generators parameters will remain the same.

5.3.2. Amplitude Jitter (AJ) [182]

Command Group Format:

/PJ,Fffff,LIII,Ss/

Command Description:

Controls the amplitude jitter function.

Amplitude Jitter Frequency (Fffff)

Command Description:

Controls the amplitude jitter frequency. Resolution is 0.25 Hz.

Valid Command Data (fffff):

Range: 0 to 30000 (0.00 Hz to 300.00 Hz)

Default: 6000 (60.00Hz)

Example:

To set the amplitude jitter frequency to 45.25 Hz:

/PJ,F4525/

Expected Response:

/C/

Remarks:

All command data 'fffff' will be rounded to the nearest 0.25 Hz automatically.

Amplitude Jitter Level (Llll)

Command Description:

Controls the amplitude jitter level in 0.1 percent steps.

Valid Command Data (lll):

Range: 0 to 980 (0.0% to 98.0%)

Default: 100 (10.0%)

Example:

To set the amplitude jitter level to 15.5%:

```
/AJ,L155/
```

Expected Response:

```
/C/
```

Amplitude Jitter Switch (Ss)

Command Description:

Enables or disables the amplitude jitter.

Valid Command Data (s):

0 - off

1 - on

Default: 0 (off)

Example:

To turn off (disable) amplitude jitter:

```
/AJ,S0/
```

Expected Response:

```
/C/
```

5.3.3. Echo Control (EC)

Command Group Format:

/EC, Lj<+/->lll,Pjp,Sjs/

Command Group Description:

Controls the echo attenuators.

Attenuation Level (Lj<+/->lll)

Command Description:

Sets the attenuation level on any one of the four echo attenuators.

Valid Command Data:

'j' selects the echo attenuator to be programmed:

- A - Station A Near End Echo Attenuator
- B - Station A Far End Echo Attenuator
- C - Station B Near End Echo Attenuator
- D - Station B Far End Echo Attenuator

'<+/->lll' determines the echo attenuator setting in 0.1 dB steps.

Range:

Near End Echo: -100 to +400 (10.0 dB gain to 40.0 dB attenuation)

Far End Echo: -200 to +300 (20.0 dB gain to 30.0 dB attenuation)

Default: +210 (21.0 dB attenuation)

Example:

To set the Station A Far End Echo Attenuator level to a 15.3 dB attenuation:

/EC,LB153/

Expected Response:

/C/

Attenuator Polarity (Pjp)

Command Description:

Controls echo attenuator path polarity.

Valid Command Data:

'j' selects the echo attenuator path:

- A - Station A Near End Echo Attenuator path
- B - Station A Far End Echo Attenuator path

C - Station B Near End Echo Attenuator path
D - Station B Far End Echo Attenuator path

'p' sets the echo polarity:
0 - positive
1 - negative
Default: 0 (positive)

Example:

To set the polarity of the Station B Near End Echo Attenuator to negative:
/EC,PC1/

Expected Response:

/C/

Echo Attenuator Switch (Sjs)

Command Description:

Enables echo attenuators at the current attenuator settings or disables all echo attenuators.

Valid Command Data:

'j' selects the set of echo attenuators to be controlled:
A - Station A echo attenuators
B - Station B echo attenuators

's' enables or disables the attenuator settings of the attenuators specified by 'j':
0 - Disabled
1 - Enabled
Default: 0 (off)

Example:

To enable the Station B echo attenuators:
/EC,SB1/

Expected Response:

/C/

5.3.4. Frequency Shift (FS) [181, 182]

Command Group Format:

/FS,F<+/->ffff,Ss/

Command Group Description:

Controls the frequency shift function.

Frequency Shift Level (F<+/->ffff)

Command Description:

To set the amount of frequency shift for the intended Impairments Generator(s).
The resolution is .25 Hz.

Valid Command Data (<+/->ffff):

Up to four decimal digits and a sign digit.
Range: -1975 to +1975 (-19.75 Hz to +19.75 Hz of frequency shift)
Default: 0 (0.00 Hz)

Example:

To set the frequency shift to 10.25 Hz:
/FS,F1025/

Expected Response:

/C/

Remarks:

All command data will be rounded to the nearest .25 Hz automatically.

Frequency Shift Switch (Ss)

Command Description:

Enables or disables the frequency shift.

Valid Command Data:

0 - Disabled (off)

1 - Enabled (on)

Default: 0 (off)

Example:

To turn on frequency shift:

/FS,S1/

Expected Response:

/C/

5.3.5 Gain / Delay (GD) [151, 152, 181, 182]

Command Group Format:

/GD,Vvv,Www,Yyy/

Command Group Description:

Controls the gain vs. frequency and envelope delay vs. frequency characteristics. The overall gain and delay response is the concatenation of the two selected responses. The delay filters are designed to introduce no gain distortion (all pass) and the gain filter have flat delay (no distortion).

Select Gain & Delay Shape (Vvv)

Command Description:

Selects gain and delay shape for the selected (see /AD, Ii/) Impairments Generator.

Valid Command Data (vv):

- 00 - no filter (flat)
- 01 - "SEG 3002" gain/delay characteristic emulation
- 02 - "Worst case" Bell 3002 (C0) gain/delay characteristic
- 03 - "Worst case" Bell C1 gain/delay characteristic
- 04 - "Worst case" Bell C2 gain/delay characteristic
- 05 - "Worst case" Bell C4 gain/delay characteristic
- 06 - "Worst case" CCITT M1020 gain/delay characteristic
- 07 - "Worst case" CCITT M1025 gain/delay characteristic
- 08 - "Worst case" CCITT M1040 gain/delay characteristic
- 09 - EIA "A1" standard gain/delay characteristic for modem testing
- 10 - EIA "B2" standard gain/delay characteristic for modem testing
- 11 - EIA "B3" standard gain/delay characteristic for modem testing
- 12 - EIA "B4" standard gain/delay characteristic for modem testing
- 13 - EIA "B5" standard gain/delay characteristic for modem testing
- 14 - EIA "C2" standard gain/delay characteristic for modem testing
- 15 - CONUS Mid Data gain/delay characteristic
- 16 - CONUS Mid Voice gain/delay characteristic
- 17 - CONUS Poor Data gain/delay characteristic
- 18 - CONUS Poor Voice gain/delay characteristic
- 19 - European Mid Data gain/delay characteristic
- 20 - European Mid Voice gain/delay characteristic
- 21 - European Poor Data gain/delay characteristic

- 22 - European Poor Voice gain/delay characteristic
- 23 - NSB gain/delay characteristic
- 24 - NTB gain/delay characteristic
- 25 - CUSTOM (See /GD,Www,Yyy/)
- 26 - Japan "JPN 1 Link" characteristic
- 27 - Japan "JPN 2 Links" characteristic
- 28 - Japan "JPN 3 Links" characteristic
- 29 - Japan "JPN 4 Links" characteristic
- 30 - Japan "JPN 5 Links" characteristic
- 31 - Japan "JPN 6 Links" characteristic
- 32 - Japan "JPN 7 Links" characteristic
- 33 - CCITT R.28 characteristic
- 34 - cable 1 gain/delay distortion characteristic
- 35 - cable 2 gain/delay distortion characteristic
- 36 - cable 3 gain/delay distortion characteristic
- 37 - China "RITT1" characteristic
- 38 - China "RITT2" characteristic
- 39 - TR_50150 gain characteristic

Example:

To select the EIA "A1" proposed standard gain/delay characteristic for modem testing:

```
/GD,V9/
```

Expected Response:

```
/C/
```

Remarks:

When /GD,V25/ - CUSTOM is selected, the gain vs. frequency is defined by the custom gain - /GD,Www/, and the delay vs. frequency is defined by the custom delay - /GD,Yyy/.

Custom Gain Filter (Www)

Command Description:

Selects a "custom" (see /GD,V25/) gain filter for the selected Impairments Generator (see /AD,Ii/).

Valid Command Data (ww):

- 00 - no filter (flat)
- 01 thru 07 - reserved
- 08 - "SEG 3002" gain characteristic emulation
- 09 - "Worst case" Bell 3002 (C0) gain characteristic
- 10 - "Worst case" Bell C1 gain characteristic
- 11 - "Worst case" Bell C2 gain characteristic
- 12 - "Worst case" Bell C4 gain characteristic
- 13 - "Worst case" CCITT M1020 gain characteristic
- 14 - "Worst case" CCITT M1025 gain characteristic
- 15 - "Worst case" CCITT M1040 gain characteristic
- 16 - EIA "A" standard gain characteristic for modem testing
- 17 - EIA "B" standard gain characteristic for modem testing
- 18 - EIA "C" standard gain characteristic for modem testing
- 19 thru 32 - reserved
- 33 - CONUS Mid Data gain characteristic
- 34 - CONUS Mid Voice gain characteristic
- 35 - CONUS Poor Data gain characteristic
- 36 - CONUS Poor Voice gain characteristic
- 37 - European Mid Data gain characteristic
- 38 - European Mid Voice gain characteristic
- 39 - European Poor Voice gain characteristic
- 40 - NSB gain characteristic
- 41 - NTB gain characteristic
- 42 - European Poor Data gain characteristic
- 43 - Japan "JPN 1 Link" gain characteristic (AD-1)
- 44 - Japan "JPN 2 Links" gain characteristic
- 45 - Japan "JPN 3 Links" gain characteristic (AD-2)
- 46 - Japan "JPN 4 Links" gain characteristic (AD-3)
- 47 - Japan "JPN 5 Links" gain characteristic (AD-4)
- 48 - Japan "JPN 6 Links" gain characteristic
- 49 - Japan "JPN 7 Links" gain characteristic

- 50 - CCITT R.28 gain characteristic
- 51 - cable 1 gain characteristic (AD-5)
- 52 - cable 2 gain characteristic (AD-6)
- 53 - cable 3 gain characteristic (AD-7)
- 54 - China "RITT" gain characteristic
- 55 - TR_50150 gain characteristic

Example:

To select cable 1 gain distortion characteristic as the custom gain filter:
/GD,V25,W51/

Expected Response: /C/

Custom Delay Filter (Yyy)

Command Description:

Selects a "custom" (see /GD,V25/) group delay filter for the selected Impairments Generator (see /AD,Ii/).

Valid Command Data:

- 00 - no filter (flat)
- 01 thru 07 - reserved
- 08 - "SEG 3002" group delay characteristic emulation
- 09 - "Worst case" Bell 3002 (C0) group delay characteristic
- 10 - "Worst case" Bell C1 group delay characteristic
- 11 - "Worst case" Bell C2 group delay characteristic
- 12 - "Worst case" Bell C4 group delay characteristic
- 13 - "Worst case" CCITT M1020 group delay characteristic
- 14 - "Worst case" CCITT M1025 group delay characteristic
- 15 - EIA "1" standard group delay characteristic for modem testing
- 16 - EIA "2" standard group delay characteristic for modem testing
- 17 - EIA "3" standard group delay characteristic for modem testing
- 18 - EIA "4" standard group delay characteristic for modem testing
- 19 - EIA "5" standard group delay characteristic for modem testing
- 20 thru 32 - reserved
- 33 - CONUS Mid Data delay characteristic
- 34 - CONUS Mid Voice delay characteristic
- 35 - CONUS Poor Data delay characteristic

- 36 - CONUS Poor Voice delay characteristic
- 37 - European Poor/Mid Data delay characteristic
- 38 - European Mid Voice delay characteristic
- 39 - European Poor Voice delay characteristic
- 40 - NSB delay characteristic
- 41 - NTB delay characteristic
- 42 - European Poor Data delay characteristic
- 43 - Japan "JPN 1 Link" delay characteristic (EDD-1)
- 44 - Japan "JPN 2 Links" delay characteristic
- 45 - Japan "JPN 3 Links" delay characteristic
- 46 - Japan "JPN 4 Links" delay characteristic
- 47 - Japan "JPN 5 Links" delay characteristic
- 48 - Japan "JPN 6 Links" delay characteristic
- 49 - Japan "JPN 7 Links" delay characteristic
- 50 - CCITT R.28 delay characteristic
- 51 - China "RITT1" delay characteristic
- 52 - China "RITT2" delay characteristic

Example:

To select the European Poor Data delay characteristic as the custom delay filter:
/GD,V25,Y42/

Expected Response:

/C/

5.3.6. Gain Hits (GH) [181, 182]

Command Group Format:

/GH,Ddddd,Iiiii,L<+/->lll,Rrrrr,ss/

Command Group Description:

Controls the gain hits generator.

Gain Hits Duration (Ddddd)

Command Description:

Controls the gain hits duration in units of 1 msec. The gain hits duration must be greater than the risetime.

Valid Command Data:

Range: 1 to 20000 (1 msec to 20000 msec)

Default: 5 (5 msec)

Example:

To set the gain hits duration to 15 msec:

/GH,D15/

Expected Response:

/C/

Gain Hits Interval (Iiiii)

Command Description:

Controls the interval between periodic gain hits.

Valid Command Data:

Range: 1 to 3200 (0.1 sec to 320.0 sec)

Default: 10 (1.0 sec)

Example:

To set the gain hits interval to 1.5 sec:

/GH,I15/

Expected Response:

/C/

Gain Hits Level (L<+/->III)

Command Description:

Controls the gain hits level in units of 0.1dB.

Valid Command Data:

Range: -200 to 60 (-20.0 dB to +6.0 dB relative to the input signal level of the gain hits generator)

Default: 30 (+3.0 dB)

Example:

To set the gain hits level to -10 dB:

/GH,L-100/

Expected Response:

/C/

Gain Hits Risetime (Rrrrr)

Command Description:

Controls the gain hits risetime in units of 0.1 msec.

Valid Command Data:

Range: 2 to 9900 (0.2 msec to 990.0 msec)

Default: 2 (0.2 msec)

Example:

To set the gain hits rise time to 5 msec:

/GH,R5/

Expected Response:

/C/

Gain Hits Switch (Ss)

Command Description:

Turns Gain Hits on or off.

Valid Command Data:

0 - off

1 - on

Default: 0 (off)

Example:

To turn on Gain Hits:

```
/GH,S1/
```

Expected Response:

```
/C/
```

5.3.7. Impulse Noise (IM) [181, 182]

Command Group Format:

/IM,Iiiii,Llll,R,Ss/

Command Group Description:

Controls the impulse noise function.

Impulse Noise Interval (Iiii)

Command Description:

Controls the interval between impulse hits.

Valid Command Data:

Range: 1 to 3200 (0.1 sec to 320.0 sec)

Default: 10 (1.0 sec)

Example:

To set the impulse noise interval to 1.5 sec:

/IM,I15/

Expected Response:

/C/

Noise Level (Llll)

Command Description:

Controls the impulse noise level in units of 0.1 dB.

Valid Command Data:

Range: 0 to 550 (0.0 dB to 55.0 dB below signal level)

Default: 400 (40.0dB)

Example:

To set the impulse noise level to 20.5 dB below signal level:

/IM,L205/

Expected Response:

/C/

Report Noise Level (R)

Command Description:

Reports the absolute impulse noise level setting in units of 0.1dBm.

Valid Command Data:

None

Response Definition:

Format : /IM,Rrrr/

'Rrrr' contains the absolute impulse noise level. Level is rr.r dBm.

Example:

/IM,R/

Expected Response:

/IM,R300/

Indicates that the absolute impulse noise level setting is 30.0 dBm

Impulse Noise Switch (Ss)

Command Description:

Turns impulse noise on or off.

Valid Command Data:

0 - off

1 - on

Default: 0 (off)

Example:

To turn on Impulse Noise:

/IM,S1/

Expected Response:

/C/

5.3.8. Impairments Generator I/O (IO)

Command Group Format:

/IO,Aa,Bb,C,I<+/->iii,L<+/->lll,Z/

Command Description:

Controls the input/output configuration, AGC, and calibration for the TAS182 of the selected Impairments Generator (see /AD,Ii/J).

Automatic Gain Control (Aa)

Command Description:

Causes the selected Impairments Generator to perform an input or output AGC operation.

Valid Command Data (a):

- 0 - Input AGC
- 1 - Output AGC

Example:

To perform an output AGC:
/IO,A1/

Expected Response:

/C/

Bypass (Bb)

Command Description:

Controls the selected Impairments Generator(s)' bypass function.

Valid Command Data (b):

- 0 - Disable bypass
- 1 - Enable bypass

Example:

To enable the bypass of the selected Impairments Generator(s):
/IO,B1/

Expected Response:

/C/

Calibration (C)

Command Description:

Forces the Impairments Generator(s) to perform a self-calibration and diagnosis. All Impairments Generator setup information is lost - the Impairments Generator assumes the factory default parameter settings and resets all signal processing modules.

Valid Command Data:

None

Example:

/IO,C/

Expected Response:

/C/

Input Level (I<+/->iii)

Command Description:

Controls the “nominal input level” of the selected Impairments Generator. This command may be used instead of the AGC when the input signal level is known.

Valid Command Data (<+/->iii):

Range: -230 to +70 (-23.0 dBm to 7.0 dBm)

Default: -100 (-10.0 dBm)

Example:

To set the input level to -11.5 dBm:

/IO,I-115/

Expected Response:

/C/

Output Level (L<+/->III)

Command Description:

Controls the output signal level of the selected Impairments Generator.

Valid Command Data (<+/->III):

Range: -500 to +0 (-50.0 dBm to +0.0 dBm)

Default: -180 (-18.0 dBm)

Example:

To set the output level to +0.0 dBm:

/IO,L0/

Expected Response:

/C/

Clear (Z)

Command Description:

Causes the Impairments Generator(s) to “clear” - i.e. establish the factory default parameter settings. Maintains all calibration values. Resets all signal processing modules.

Valid Command Data:

None

Example:

/IO,Z/

Expected Response:

/C/

5.3.9. Line Control (LC)

Command Group Format:

/LC,Bjb,Dd,Fjf,Mm,Xjx,Yjy/

Command Group Description:

Controls the central office simulator line configuration parameters.

Hybrid Balance (Bjb)

Command Description:

Selects internal or external hybrid balance network.

Valid Command Data:

'j' determines the hybrid impedance to be selected:

A - Station A Hybrid

B - Station B Hybrid

'b' selects the impedance:

0 - Internal 604 Ω impedance (default)

1 - external supplied impedance

Example:

To set the Station B Hybrid to internal:

/LC,BB0/

Expected Response:

/C/

Simulation Direction (Dd) [151, 181]

Command Description:

For single direction impairment models (151 and 181), sets A→B or B→A simulation direction. Normally, these models place the Impairments Generator in the A→B transmission path. If B→A direction is set, the simulator places the Impairments Generator in the B→A path.

Valid Command Data (d):

- 0 - A→B (default)
- 1 - B→A

Example:

To set the simulation direction to A→B:
/LC,D0/

Expected Response:

/C/

Channel Mode (Fjf)

Command Description:

Sets internal or external 2-Wire channel mode for the selected channel.

Valid Command Data:

'j' determines the channel to be set:
A - Channel A→B
B - Channel B→A

'f' sets the mode to internal or external:
0 - Internal (Default)
1 - External

Example:

To set the B→A channel mode to internal:
/LC,FB0/

Expected Response:

/C/

Network Interface Mode (Mm)

Command Description:

Selects the network interface mode:

Valid Command Data (m):

0 - Private 4-Wire
1 - Switched (Dialed) 2-Wire
2 - Private 2-Wire
3 - Auto-Switched (No Dialing) 2-Wire
4 - Private 4-wire (station A) / Switched 2-wire (station B)
Default: 0 (Private 4-Wire)

Example:

To set the network interface mode to Private 2-Wire:
/LC,M2/

Expected Response:

/C/

Loopback Relay (Xjx)

Command Description:

Controls the station 4-wire loopback relay (TEK5, TEK6) relay contacts.

Valid Command Data:

'j' determines the station to be controlled:

A - Station A
B - Station B

'x' determines the state of the relay contacts:

0 - Open
1 - Close
Default: 1 (Close)

Example:

To open the loopback relay of station B:
/LC,XB0/

Expected Response:

/C/

Programming Resistor (Yjy)

Command Description:

Controls the station 2-wire level programming resistor contacts (pins 7 and 8).

Valid Command Data:

'j' determines the station to be controlled:

A - Station A

B - Station B

'y' determines resistance between pins 7 and 8:

0 - Open (Default)

1 - 866 Ω resistor

Example:

To set the programming resistor of station A to 866 Ω :

/LC,YA1/

Expected Response:

/C/

5.3.10. Signal Measurements (MM)

Command Group Format:

/MM,R/

Command Group Description:

Initiates a level measurement at the selected monitor point (AD,Mmm).

Report Measurement (R)

Command Description:

Reports the true rms level measurement of the selected signal.

Valid Command Data:

None

Response Definition:

Format: /MM,L<+/->lll/

/MM,L- - - /

/MM,L++++/

'L<+/->lll' contains the measured signal input level in units of 0.1 dBm.

'lll' - level is ll.l dBm

'- - -' - level is less than -50.0 dBm

'++++' - level is greater than +10.0 dBm

Example:

/MM,R/

Expected Response:

/MM,L-168/; Indicates that the monitored signal level is -16.8 dBm.

5.3.11. Nonlinear (Intermodulation) Distortion (NL) [181, 182]

Command Group Format:

/NL,Qqqq,Cccc,Mm,ss/

Command Group Description:

Controls second and third order nonlinear distortion (NLD) functions.

2nd Order Distortion Level (Qqqq)

Command Description:

Controls second order distortion level in 0.1 dB steps.

Valid Command Data (qqq):

Range: 200 to 600 (20.0 dB to 60.0 dB below signal, as measured by IEEE standard 4-tone technique)

Default: 520 (52.0 dB below signal)

Example:

To set the second order distortion level to 35.4 dB below the signal level:

/NL,Q354/

Expected Response:

/C/

3rd Order Distortion Level (Cccc)

Command Description:

This command controls the third order distortion levels in 0.1 dB steps.

Valid Command Data:

Range: 200 to 600 (20.0 dB to 60.0 dB below signal)

Default: 500 (50.0 dB below signal)

Example:

To set the third order distortion level to 20.0 dB below the signal level:

/NL,C200/

Expected Response:

/C/

Nonlinear Distortion Mode (Mm)

Command Description:

Controls the Nonlinear distortion Mode.

Valid Command Data (m):

0 - Expansive
1 - Compressive

Example:

To set the Nonlinear Distortion Mode to Compressive:
/NL,M1/

Expected Response:

/C/

Nonlinear Distortion Switch (Ss)

Command Description:

Turns nonlinear distortion on or off.

Valid Command Data (s):

0 - off
1 - on
Default: 0 (off)

Example:

To turn on Nonlinear Distortion:
/NL,S1/

Expected Response:

/C/

5.3.12. Pulse-Code Modulation (PC) [151, 152, 181, 182]

Command Group Format:

/PC,Cc,Ll,Pp,Rr,Ss/

Command Group Description:

Controls the Pulse-Code Modulation (PCM) simulation.

Coding (Cc)

Command Description:

Selects the coding for the PCM simulation.

Valid Command Data (c):

0 - μ -law
1 - a-law
Default: 0 - μ -law

Example:

To select a-law for the PCM simulation:
/PC,C1/

Expected Response:

/C/

Links (Ll)

Command Description:

Selects the number of links for the PCM simulation.

Valid Command Data (c):

1 - 3 links
Default: 1 link

Example:

To select 2 links for the PCM simulation:
/PC,L2/

Expected Response:

/C/

Remarks:

Available on Model 182 only.

Position (Pp)

Command Description:

Selects the position of the PCM simulation in the impairment sequence.

Valid Command Data (c):

1 - first impairment
0 - last impairment
Default: 0 - last impairment

Example:

To select the PCM simulation as the last impairment:
/PC,P0/

Expected Response:

/C/

Remarks:

Available on Model 182 only.

Robbed Bit Signaling (Rr)

Command Description:

Enables or disables robbed bit signaling (alternating 0 and 1) for the PCM simulation.

Valid Command Data (r):

0 - off
1 - on
Default: 0 (RBS off)

Example:

To enable RBS for the PCM simulation:
/PC,R1/

Expected Response:

/C/

PCM Switch (Ss)

Command Description:

Turns PCM on or off.

Valid Command Data (s):

0 - off

1 - on

Default: 0 (PCM off)

Example:

To turn on (enable) PCM with the selected settings:

/PC,S1/

Expected Response:

/C/

5.3.13. Phase Hits (PH) [181, 182]

Command Group Format:

/PH,Ddddd,Iiiii,Llll,Rrrrr,ss/

Command Group Description:

Controls the phase hits generator.

Phase Hits Duration (Ddddd)

Command Description:

Controls the phase hits duration in units of 1 msec. The phase hits duration must be greater than the risetime.

Valid Command Data:

Range: 1 to 20000 (1 msec to 20000 msec)

Default: 5 (5 msec)

Example:

To set the phase hits duration to 15 msec:

/PH,D15/

Expected Response:

/C/

Phase Hits Interval (Iiiii)

Command Description:

Controls the interval between periodic phase hits.

Valid Command Data:

Range: 1 to 3200 (0.1 sec to 320.0 sec)

Default: 10 (1.0 sec)

Example:

To set the phase hits interval to 1.5 sec:

/PH,I15/

Expected Response:

/C/

Phase Hits Level (LIII)

Command Description:

Controls the phase hits level in units of 0.1 degrees.

Valid Command Data:

Range: 0 to 900 (0.0 degrees to 90.0 degrees)

Default: 450 (45.0 degrees)

Example:

To set the phase hits level to 30.0 degrees:

/PH,L300/

Expected Response:

/C/

Phase Hits Risetime (Rrrr)

Command Description:

Controls the phase hits risetime in units of 0.1 msec.

Valid Command Data:

Range: 2 to 9900 (0.2 msec to 990.0 msec)

Default: 2 (0.2 msec)

Example:

To set the phase hits rise time to 5 msec:

/PH,R5/

Expected Response:

/C/

Phase Hits Switch (Ss)

Command Description:

Turns Phase Hits on or off.

Valid Command Data:

0 - off

1 - on

Default: 0 (off)

Example:

To turn on Phase Hits:

/PH,S1/

Expected Response:

/C/

5.3.14. Phase Jitter (PJ) [181, 182]

Command Group Format:

/PJ,Ffffff,LIII,Ss/

Command Description:

Controls the phase jitter function.

Phase Jitter Frequency (Ffffff)

Command Description:

Controls the phase jitter frequency. Resolution is 0.25 Hz.

Valid Command Data (fffff):

Range: 0 to 30000 (0.00 Hz to 300.00 Hz)

Default: 6000 (60.00Hz)

Example:

To set the phase jitter frequency to 45.25 Hz:

/PJ,F4525/

Expected Response:

/C/

Remarks:

All command data 'fffff' will be rounded to the nearest 0.25 Hz automatically.

Phase Jitter Level (Llll)

Command Description:

Controls the phase jitter level in units of 0.1 degree steps.

Valid Command Data (lll):

Range: 0 to 450 (0.0° to 45.0°)

Default: 0 (0.0°)

Example:

To set the phase jitter level to 15.5°:

```
/PJ,L155/
```

Expected Response:

```
/C/
```

Phase Jitter Switch (Ss)

Command Description:

Enables or disables the phase jitter.

Valid Command Data (s):

0 - off

1 - on

Default: 0 (off)

Example:

To turn off (disable) phase jitter:

```
/PJ,S0/
```

Expected Response:

```
/C/
```

5.3.15. Random (White) Noise (RN) [151, 152, 181, 182]

Command Group Format:

/RN,Llll,Ss,Ww/

Command Description:

Controls the white noise generator of the selected Impairments Generator (see /AD, Ii/).

White Noise Output Level (Llll)

Command Description:

Controls the white noise output level of the selected Impairment Generator (see /AD,Ii/).

Valid Command Data (lll):

'lll' determines the noise level in units of 0.1 dBm.
Range: 150 to 900 (15.0 dBm to 90.0 dBm)
Default: 320 (32.0 dBm)

Example:

To set the output level of the white noise generator to 62.5 dBm:
/RN,L625/

Expected Response:

/C/

White Noise Generator Switch (Ss)

Command Description:

Turns the white noise generator of the selected Impairments Generator on or off.

Valid Command Data (s):

0 - off
1 - on
Default: 0 (off)

Example:

To turn on the white noise generator of the selected Impairments Generator:
/RN,S1/

Expected Response:

/C/

Noise Weighting (Ww)

Command Description:

Controls the selected Impairments Generator's white noise output level correction for various instrument measuring filters.

Valid Command Data:

0 - C-Message
1 - 3 kHz Flat
2 - Psophometric
Default: 0 (C-Message)

Example:

To select the Psophometric filter as the weighting filter:
/RN,W2/

Expected Response:

/C/

5.3.16. Satellite Delay (SD) [151, 152, 181, 182]

Command Group Format:

/SD,Ddddd,Ss/

Command Group Description:

Controls the propagation delay for the selected Impairments Generator (see /AD,Ii/).

Delay Magnitude (Ddddd)

Command Description:

Controls the satellite (propagation) delay for the selected Impairments Generator in 0.125 ms steps. The parameter value is the number of steps of 0.125 ms needed to set the desired value, not the actual value in ms (see example below). See section 3.3.7.3 for more information.

Valid Command Data (dddd):

Range: 0 to 12799 (0 to 1599.875 ms)

Default: 4400 (550 ms)

Example:

To set a delay amount of 34.5 ms, the data value in steps would be

of steps = (desired amount in ms) / (0.125 ms per step)

of steps = 34.5 (ms) / 0.125 (ms per step)

therefore # of steps = 276

Therefore, to set the delay to 34.5ms, the user would send

/SD,D276/

Expected Response:

/C/

Satellite Delay Switch (Ss)

Command Description:

Enables or disables the selected Impairments Generator's satellite delay.

Valid Command Data (s):

0 - Disable

1 - Enable

Default: 0 (Disabled)

Example:

To Enable the satellite delay:

```
/SD,S1/
```

Expected Response:

```
/C/
```

5.3.17. Single Frequency Interference (SF) [182]

Command Group Format:

/SF,Fffff,Llll,Ss/

Command Description:

Controls the single frequency interference function.

Single Frequency Interference (SFI) Frequency (Ffff)

Command Description:

Controls the SFI frequency. Resolution is 1.0 Hz.

Valid Command Data (ffff):

Range: 0 to 3400 (0 Hz to 3400 Hz)

Default: 2600 (2600 Hz)

Example:

To set the SFI frequency to 1050.0 Hz:

/PJ,F1050/

Expected Response:

/C/

Single Frequency Interference (SFI) Frequency (LIII)

Command Description:

Controls the SFI level. Resolution is 0.1dB.

Valid Command Data (III):

Range: 0 to 500 (0dB to 500.0 dB below output level)

Default: 100 (10.0Hz)

Example:

To set the SFI level to 32.5dB:

```
/SF,L325/
```

Expected Response:

```
/C/
```

Single Frequency Interference (SFI) Switch (Ss)

Command Description:

Enables or disables SFI.

Valid Command Data (s):

0 - off

1 - on

Default: 0 (off)

Example:

To enable SFI:

```
/SF,S1/
```

Expected Response:

```
/C/
```

5.3.18. Network Signaling (SG)

Command Group Format:

```
/SG,Bjbbb,Cjc,D<+/-  
>dd,Ee,Fjffff,Hjhh,Iii,Kk,LLL,Mm,Pjpp,Rjrrr,Ss,Tjttt,Yyyy,Zz/
```

Command Group Description:

Controls the central office simulator signaling parameters.

Busy Cadence (Bjbbb)

Command Description:

Controls busy cadence. The parameter value is the number of steps of 25 ms or 50 ms (see /SG,Kk/) needed to set the desired value, not the actual value in ms (see example below).

Valid Command Data:

'j' determines the cadence time to be set:

A - Busy on time (Default 0.5 seconds)

B - Busy off time (Default 0.5 seconds)

'bbb' determines cadence time in 25 ms or 50 ms steps.

Range: 0 to 200 (0 ms to 5000 ms or 10000 ms)

Example:

To set the busy on time to 150 ms, the data value in steps would be

of steps = (desired amount in ms) / (50 ms per step)

of steps = 150(ms) / 50(ms per step)

∴ # of steps = 3

Therefore, to set the busy on time to 150 ms, the user would send

```
/SG,BA3/
```

Expected Response:

```
/C/
```

Range: -40 to +0 (-40 dBm to 0 dBm)

Default: -10 (-10 dBm)

Reverse Polarity Signaling (Ee)

Command Description:

Enables or disables reverse polarity signaling for 2-wire switched mode operation.

Valid Command Data (e):

0 - Disable (turn off) reverse polarity signaling

1 - Enable (turn on) reverse polarity signaling

Default: 0 (Disabled)

Example:

To enable reverse polarity signaling:

/SG,E1/

Expected Response:

/C/

Signaling Tones Frequencies (Fjffff)

Command Description:

Controls the Frequencies for signaling tones.

Valid Command Data:

'j' determines the tone to be set:

A - Dial tone frequency 1 (Default 3500 = 350.0 Hz)

B - Dial tone frequency 2 (Default 4400 = 440.0 Hz)

C - Busy frequency 1 (Default 4800 = 480.0 Hz)

D - Busy frequency 2 (Default 6200 = 620.0 Hz)

E - Audible ring frequency 1 (Default 4400 = 440.0 Hz)

F - Audible ring frequency 2 (Default 4800 = 480.0 Hz)

'ffff' determines the tone frequency in units of 0.1 Hz:

Range: 0 (tone off) or 1000 to 7200 (100.0 Hz to 720.0 Hz)

Example:

To set the busy frequency 2 to 600.0 Hz:

/SG,FD6000/

Expected Response:

/C/

Remarks:

A setting of 0 will turn the selected tone off. No values between 0 and 1000 are allowed. This allows for one of two tones to be effectively turned off for cases where only one frequency is required (also supports having no tone).

Independent Loop Current Level (Hjhh)

Command Description:

Controls the DC loop current level at the specified station.

Valid Command Data:

'j' determines the station to be controlled:

- A - Station A loop current
- B - Station B loop current

'hh' determines the loop current in 8 mA steps:

- Range: 1 to 15 (8 mA to 120 mA)
- Default: 4 (32 mA)

Example:

To set the station A loop current to 24 mA, the data value in steps would be

$$\# \text{ of steps} = (\text{desired amount in mA}) / (8 \text{ mA per step})$$

$$\# \text{ of steps} = 24(\text{mA}) / 8(\text{mA per step})$$

$$\therefore \# \text{ of steps} = 3$$

Therefore, to set the station A loop current to 24 mA, the user would send

/SG,HA3/

Expected Response:

/C/

Combined Station Loop Current Level (Iii)

Command Description:

Controls the DC loop current level at both station A and B.

Valid Command Data (ii):

'ii' determines the loop current in 8 mA steps.

Range: 1 to 15 (8 mA to 120 mA)

Default: 4 (32 mA)

Example:

To set the loop current of station A and station B to 24 mA (see /SG,Hjhh/ for more detail):

/SG,I3/

Expected Response:

/C/

Signaling Cadence Resolution (Kk)

Command Description:

Controls the value of the signaling cadence resolution (step size) for the Rjrrr, Bjbbb, and Tjttr subframes of the SG command group.

Valid Command Data (k):

0 - resolution of 50 ms (cadence range = 0 to 10000 ms)

1 - resolution of 25 ms (cadence range = 0 to 5000 ms)

Default: 0 (resolution of 50 ms)

Example:

To set the resolution to 25 ms:

/SG,K1/

Expected Response:

/C/

Ring Level (LII)

Command Description:

Controls the ring level in 1 Vrms steps.

Valid Command Data:

Range: 1 to 100 (1 Vrms to 100 Vrms)

Default: 85 (85 Vrms)

Example:

To set the ring level to 60 Vrms:

/SG,L60/

Expected Response:

/C/

Busy Station (Mm)

Command Description:

Changes the status of the selected station to "busy".

Valid Command Data (m):

A - Make station A busy

B - Make station B busy

C - Clear

Example:

To clear the station status of both stations:

/SG,MC/

Expected Response:

/C/

Dial Pulse Make/Break Intervals (Pjpp)

Command Description:

Controls the dial pulse make/break intervals. Dial pulse digits that do not meet the break/make intervals specified will not be recognized.

Valid Command Data:

'j' determines the interval to be set:

- A - Minimum break time (Default 45 ms)
- B - Maximum break time (Default 75 ms)
- C - Minimum make time (Default 25 ms)
- D - Maximum make time (Default 55 ms)

'pp' determines the time length of the interval in 1 ms steps.

Range: 10 to 90 (10 ms to 90 ms)

Example:

To set the minimum make time to 70 ms:

```
/SG,PC70/
```

Expected Response:

```
/C/
```

Ringling and Audible Ringing Cadence (Rjrrr)

Command Description:

Controls ringing and audible ringing cadence.

Valid Command Data:

'j' determines the cadence interval to be set:

- A - On time 1 (Default 0)
- B - On time 2 (Default 0)
- C - On time 3 (Default 2 sec.)
- D - Off time 1 (Default 0)
- E - Off time 2 (Default 0)
- F - Off time 3 (Default 4 sec.)

'rrr' determines cadence time in 25 ms or 50 ms steps (see /SG,Kk/):

Range: 0 to 200 (0 ms to 5000 ms or 10000 ms)

Example:

To set off time 3 to 2.5 sec, the data value in steps would be

of steps = (desired amount in ms) / (50 ms per step)

of steps = 2500(ms) / 50(ms per step)

∴ # of steps = 50

Therefore, to set off time 3 to 2.5 sec, the user would send

/SG,RF50/

Expected Response:

/C/

Send Signal (Ss)

Command Description:

Selects and sends a signal to either station.

Valid Command Data (s):

- A - Send ringing to station A
- B - Send ringing to station B
- C - Send dial tone to station A
- D - Send dial tone to station B
- E - Send busy to station A
- F - Send busy to station B
- G - Clear all

Example:

To send dial tone to station B:
/SG,SD/

Expected Response:

/C/

Dial Tone Cadence (Tjttt)

Command Description:

Controls dial tone cadence.

Valid Command Data:

'j' determines the cadence time to be set:

- A- Dial tone on time 1
- B- Dial tone on time 2
- C- Dial tone on time 3
- D- Dial tone off time 1
- E- Dial tone off time 2
- F- Dial tone off time 3

'ttt' determines cadence time in 25 ms or 50 ms steps:

Range: 0 to 200 (0 ms to 5000 ms or 10000 ms)

Example:

To set dial tone on time 2 to 2.5 sec, the data value in steps would be

of steps = (desired amount in ms) / (50 ms per step)

of steps = 2500(ms) / 50(ms per step)

∴ # of steps = 50

Therefore, to set dial tone on time 2 to 2.5 sec, the user would send

/SG,TB50/

Expected Response:

/C/

Ring Frequency (Yyyy)

Command Description:

Controls the ring frequency in units of 0.1 Hz.

Valid Command Data (yyy):

Range: 140 to 750 (14.0 Hz to 75.0 Hz)

Default: 200 (20.0 Hz)

Example:

To set the ring frequency to 42.0 Hz:

/SG,Y420/

Expected Response:

/C/

Report Line Status (Zz)

Command Description:

Initiates a report of the line status.

Valid Command Data (z):

A - Report the status of station A

B - Report the status of station B

Response Definition:

Format: /SG,Zzzzzzzzz/

'Zzzzzzzzz' contains the station status. The status digits from left to right are:

Ring back on (1)

Ringing on (1)

Busy on (1)

Dial tone on (1)

Off hook (1)

Connected (1)

Awaiting DTMF (1)

Awaiting dial pulses (1)

Example:

With station A off hook and receiving dial tone.

/SG,ZA/

Expected Response:

/SG,Z00011000/

Indicates dial tone on and off hook.

Remarks:

The line status is valid **only** in the switched line mode.

5.3.19. Switching (SW)

Command Group Format:

/SW,Llllll,Mmmmmm,Nnnnnn,Qqqq,Rr,Tjtttttttttt,Zz/

Command Group Description:

Controls the central office simulator switching parameters.

Disconnect Signal Delay (Llllll)

Command Description:

Controls the disconnect signal delay in 1 ms steps. Disconnect signal delay is defined as the time from the completion of the on hook delay to the transmission of the disconnect signal. The disconnect signal is sent to the station that remains off hook after a call is terminated in 2 wire switched mode.

Valid Command Data (mmmmm):

Range: 1 to 30000 (1 ms to 30000ms)

Default: 1 (1 ms)

Example:

To set the disconnect signaling delay to 50 ms:

/SW,L50/

Expected Response:

/C/

Switching Delay (Mmmmmm)

Command Description:

Controls the switching delay, i.e. the time between the end of the dialing sequence and the connection of the call, measured in 1 ms steps.

Valid Command Data (mmmmm):

Range: 1 to 25000 (1 ms to 25000ms)

Default: 1 (1 ms)

Example:

To set the switching delay to 50 ms:

/SW,M50/

Expected Response:

/C/

Dial Tone Delay (Nnnnnn)

Command Description:

Controls the dial tone delay, i.e. the time between station off hook to dial tone, measured in 1 ms steps.

Valid Command Data (nnnnn):

Range: 2 to 25000 (2 ms to 25000 ms)

Default: 2 (2 ms)

Example:

To set the dial tone delay to 25 ms:

/SW,N25/

Expected Response:

/C/

On Hook Delay (Qqqq)

Command Description:

Controls the on hook recognition delay, i.e. the time from station on hook to recognition of on hook status at the line control unit. This time is specified in 1 ms steps.

Valid Command Data (qqq):

Range: 1 to 255 (1 ms to 255 ms)

Default: 255 (255 ms)

Example:

To set the on hook delay to 200 ms:

/SW,Q200/

Expected Response:

/C/

Disconnect Signal Selection (Rr)

Command Description:

Selects the tone for disconnect signal.

Valid Command Data (mmmmm):

0 - None
1 - Busy Tone
2 - Dial Tone
Default: 0 (None)

Example:

To select dial tone as the disconnect signal:
/SW,R2/

Expected Response:

/C/

Station Telephone Number (Tjtttttttttttt)

Command Description:

Sets the telephone number for station A or B.

Valid Command Data:

'j' determines which telephone number is set:
A - Station A
B - Station B

'tttttttttttt' contains the telephone number (up to 15 decimal digits):

't' Range: 0 thru 9, *, #, +

Default: Station A '5550123'

Default: Station B '5559876'

Example:

To set the Station A telephone number to '123':
/SW,TA123/

Expected Response:

/C/

Report Received Number (Zz)

Command Description:

Initiates a report of the station A or station B received (dialed) telephone number.

Valid Command Data (z):

A - Station A received number
B - Station B received number

Response Definition:

Format: /SW,Zjzzzzzzzzzzzzzzzzzz/

'j' contains the station:

A - Station A
B - Station B

'zzzzzzzzzzzzzzzzzz' contains maximum 15 dialed digits:

'z' - 0 thru 9, *, # (first digit received at left, last digit at right)

Example:

/SW,ZB/

Expected Response:

/SW,ZB_____/

Indicates no digits dialed to station B.

This page intentionally left blank.

6.0. ERROR CODES

The following is a list of the system error codes and their descriptions:

Error Code	Description
001	Parameter value error
002	Command syntax error
003	Reserved
004	Bad data on recall function
005	Central office module - bad response
006	Impairments generator 1 - bad response
007	Impairments generator 2 - bad response
008	Central office module - didn't accept data
009	Central office module - no response
010	Impairments generator 1 - didn't accept data
011	Impairments generator 1 - no response
012	Impairments generator 2 - didn't accept data
013	Impairments generator 2 - no response
014	Reserved
015	Input AGC failure
016	Output AGC failure
017	Central office module not present at power-up
018	Central office module initialization error
019	Impairments generator 1 initialization error
020	Impairments generator 2 initialization error
021	A→B "busy signal" calibration failure
022	B→A "busy signal" calibration failure
023	Impairments generator 1 level calibration failure
024	Impairments generator 2 level calibration failure
025	A→B 2-wire output ckt. calibration failure
026	A→B 4-wire output ckt. calibration failure
027	B→A 2-wire output ckt. calibration failure
028	B→A 4-wire output ckt. calibration failure

Error Code	Description
029	A→B “dial tone” calibration failure
030	B→A “dial tone” calibration failure
031	A→B noise calibration failure (2-wire)
032	A→B noise calibration failure (4-wire)
033	B→A noise calibration failure (2-wire)
034	B→A noise calibration failure (4-wire)
035	AGC and INLVL illegal during BYPASS (A→B)
036	AGC and INLVL illegal during BYPASS (B→A)
037	Reserved
038	Reserved
039	Users are not allowed to turn on echo in 4-wire mode
040	Incompatible hardware
041	A→B impulse noise calibration failure
042	B→A impulse noise calibration failure
043	Impairments generator 1 or PCM generator 1 level calibration failure
044	Impairments generator 2 or PCM generator 2 level calibration failure

7.0. TECHNICAL SPECIFICATIONS

Some of the sections or items in this chapter apply only to certain model(s) of the TAS 100 family. The notation [*model, ...*] indicates that the section or item only applies to the model(s) listed inside the brackets. Otherwise, the section applies to all TAS 100 family models.

7.1. General

Power Requirements

Voltage	115/230 VAC (selectable) +10%, -13%
Frequency	48 to 63 Hz
Dissipation	100 watts maximum

Operating Environment

Temperature	0 to 50 degrees C (32 to 122 degrees F)
Humidity	10% to 90%, noncondensing

Dimensions and Weight

Height	5.22 inches
Width	17.08 inches
Depth	14.44 inches
Weight	25 pounds

7.2. Signal Measurement

Level Measurement

Range	+10.0 dBm to -50.0 dBm
Resolution	0.1 dB
Accuracy	+/- 0.4 dBm
Measurement Points	Station A transmit Station A 4-wire receive Station A 2-wire receive Station B transmit Station B 4-wire receive Station B 2-wire receive

7.3. Impairments Generator I/O

Input Level

Range	+7.0 dBm to -23.0 dBm
-------	-----------------------

Output Level (1 kHz Tone, Impairments OFF with Flat Gain/Delay)

Range	0.0 dBm to -50.0 dBm
Resolution	0.1 dB
Accuracy	+/- 0.3 dB @ 0 dBm +/- 0.4 dB @ -40.0 dBm +/- 0.8 dB @ -50.0 dBm

7.4. Residual Characteristics

Idle Channel Noise	Less than 20 dBm (3K Flat) (All impairments off, output level = 20 dBm, stations A and B terminated in 600 ohms)
Residual Phase Jitter	Less than 0.2 degrees
Residual Amplitude Jitter	Less than 0.2 percent
Channel Separation (Crosstalk in 4-wire mode)	greater than 60 dB

7.5. Transmission Impairments**White Noise [151, 152, 181, 182]**

Generator Type	pseudorandom
Period Choices	20.97 seconds
Crest Factor	approx. 4.7
Level Calibration or Psophometric	C-Message, 3.0 kHz Flat,
Level Range	20.0 dBm to 90.0 dBm (-70.0 dBm to 0.0 dBm)
Level Resolution	0.1 dB
Level Accuracy	+/- 0.5 dB [20 dBm to 90 dBm (-70.0 dBm to 0.0 dBm) with C-Message calibration and a channel output level = -20 dBm]

Intermodulation Distortion [181, 182]

Mode	Expansive or Compressive
------	--------------------------

Second Order Intermodulation Distortion

Range	20 to 60 dB below signal
Resolution	0.1 dB
Accuracy	0.5 dB (at 40 dB below signal)

Third Order Intermodulation Distortion

Range	20 dB to 60 dB below signal
Resolution	0.1 dB
Accuracy	0.5 dB (at 40 dB below signal)

Frequency Shift [181, 182]

Offset Choices	-19.75 to +19.75 Hz
----------------	---------------------

Resolution	0.25 Hz
Accuracy	+/- 0.05 Hz +/- 0.01% of setting

Amplitude Jitter [182]

Level Range	0.0 to 98.0%
Level Resolution	0.1%
Level Accuracy	+/- 0.5% of setting (Freq. = 60.0 Hz)
Frequency Range	0.0 to 300.0 Hz
Frequency Resolution	0.25 Hz
Frequency Accuracy	+/- 0.05 Hz +/- 0.01% of setting
Modulation Waveforms	sine-wave

Phase Jitter [181, 182]

Level Range	0.0 to 45.0 degrees p-p
Level Resolution	0.1%
Level Accuracy	+/- 0.3 degrees (Freq. = 60.0 Hz, Level = 10 degrees)
Frequency Range	0.0 to 300.0 Hz
Frequency Resolution	0.25 Hz
Frequency Accuracy	+/- 0.05 Hz +/- 0.01% of setting
Modulation Waveforms	sine-wave

Gain Hits [181, 182]

Level Range	-20.0 to +6.0 dB
Level Resolution	0.1 dB
Level Accuracy	+/- 0.1 dB
Rise/Fall Time Range	0.2 to 990 msec

Rise/Fall Time Resolution	0.1 msec
Rise/Fall Time Accuracy	+/-0.05 msec +/- 2% of setting
Duration Range	1.0 to 20000 msec
Duration Resolution	1.0 msec
Duration Accuracy	+/- 0.05% of setting
Interval Range	0.1 to 320.0 sec
Interval Resolution	0.1 sec
Interval Accuracy	+/- 0.05% of setting

Phase Hits [181, 182]

Level Range	0.0 to 90.0 degrees
Level Resolution	0.1 degrees
Level Accuracy	+/- 0.3 degrees (level = 10.0 degrees)
Rise/Fall Time Range	0.2 to 990 msec
Rise/Fall Time Resolution	0.1 msec
Rise/Fall Time Accuracy	+/-0.05 msec +/- 2% of setting
Duration Range	1.0 to 20000 msec
Duration Resolution	1.0 msec
Duration Accuracy	+/- 0.05% of setting
Interval Range	0.1 to 320.0 sec
Interval Resolution	0.1 sec
Interval Accuracy	+/- 0.05% of setting

Impulse Noise [181, 182]

Impulse Type	IEEE Standard
Level Range	0.0 to 55.0 dB below signal
Level Resolution	0.1 dB
Level Accuracy	+/- 0.5 dB (output level = -20.0 dBm, impulse level = 10 dB)
Interval Range	0.1 to 320.0 sec
Interval Resolution	0.1 sec
Interval Accuracy	+/- 0.05% of setting
Calibration	C-Notched

Gain/Group Delay Distortion [151, 152, 181, 182]

Gain Filters	Independent or Combined with Group Delay Filter
Group Delay Filters	Independent or Combined with Gain Filter
Filter Type	Digital

Gain Response Characteristics

Flat
 3002 (Two types)
 Bell C1, C2, C4
 CCITT M1020, M1025, M1040
 EIA A, B, C
 DOD CONUS MD, MV, PD, PV
 DOD EUROPEAN MD, MV, PD, PV
 DOD NSB, NTB
 JAPANESE 1-7
 CCITT R.28
 EIA/CCITT CABLE 1-3
 RITT
 TR_50150

Group Delay Response Characteristics

Flat
3002 (Two types)
Bell C1, C2, C4
CCITT M1020, M1025
EIA 1-5
DOD CONUS MD, MV, PD, PV
DOD EUROPEAN MD, MV, PD, PV
DOD NSB, NTB
JAPANESE 1-7
CCITT R.28
RITT 1-2

Transmission Time Delay of Any Gain Filters

2.12 msec

Transmission Time Delay of Group Delay Filters:

Flat = 2.8 msec
Worst case Bell 3002 characteristic = 1.36 msec
Worst case Bell C1 characteristic = 1.2 msec
Worst case Bell C2 characteristic = 1.3 msec
Worst case Bell C4 characteristic = 2.0 msec
SEG FA-1445 characteristic emulation = 1.9 msec
Worst case CCITT M1020 characteristic = 1.3 msec
Worst case CCITT M1025 characteristic = 1.2 msec
EIA 1 characteristic = 2.9 msec
EIA 2 characteristic = 1.9 msec
EIA 3 characteristic = 1.7 msec
EIA 4 characteristic = 0.7 msec
EIA 5 characteristic = 1.5 msec
CONUS Mid Data characteristic = 2.4 msec
CONUS Mid Voice characteristic = 1.6 msec
CONUS Poor Data characteristic = 2.4 msec
CONUS Poor Voice characteristic = 1.1 msec
European Mid Data characteristic = 2.5 msec
European Poor Data characteristic = 2.5 msec
European Mid Voice characteristic = 1.9 msec
European Poor Voice characteristic = 1.6 msec
NSB characteristic = 1.1 msec
NTB characteristic = 1.1 msec
JPN 1 link characteristic = 2.3 msec
JPN 2 link characteristic = 1.8 msec
JPN 3 link characteristic = 1.8 msec
JPN 4 link characteristic = 1.7 msec
JPN 5 link characteristic = 1.9 msec

JPN 6 link characteristic = 1.6 msec

JPN 7 link characteristic = 1.3 msec

R 28 characteristic = 1.8 msec

RITT1 characteristic = 0.8 msec

RITT2 characteristic = 1.2 msec

Satellite Delay [151, 152, 181, 182]

Range	0 to 1599.875 msec (relative to background delay)
Resolution	125 usec
Accuracy	+/- 0.01%

PCM [151, 152, 181, 182]

# of Links Simulated	0-1, 0-3 (Model 182 only)
Sampling Rate	8.0 kHz
PCM Coding for Each Link	None (analog bypass), mu-law, or A-law
Bit Rate	64 kbps PCM
PCM Robbed Bit Signaling	Least significant bit at every sixth frame (samples) Pattern inserted is 01 (alternating 0 and 1)
Impairment Position	First or last impairment selectable (Model 182 only)

Echo Attenuators (Near A, Far A, Near B, Far B)

Level	-10.0 to +40.0 dB (near echo) -20.0 to +30.0 dB (far echo)
Resolution	0.1 dB
Accuracy	+/- 0.5 dB @ +20.0 dB

Single Frequency Interference

Frequency Range	200.0 to 3400.0 Hz
Frequency Resolution	1.0 Hz
Frequency Accuracy	+/- 0.02 Hz +/- 0.01% of setting
Level Range	0.0 to 50.0 dB below the level of the output signal
Level Resolution	0.1 dB
Level Accuracy	Relative to channel output (freq=2600Hz) +/- 0.5 dB (above level range of 40.0 dB, from 400-3300Hz)

7.6. Central Office Emulation

General

Operating Modes	2-wire switched (loop start), 2-wire auto-switched (loop start), 2-wire private-line, or 4-wire private-line 4-wire private-line/2-wire switched (GT-Cellular Lite)
Nominal Input Impedance	600 ohms +/- 30 ohms
Nominal Output Impedance	600 ohms +/- 30 ohms
Internal Hybrid Balance Impedance	604 ohms +/- 6 ohms
Transhybrid Loss (2-wire = Balance Impedance)	40 dB minimum (300 Hz to 3500 Hz)

Constant Current Feed Generator (Switched Line Modes)

Current Source Range (Station A and B independently controlled)	8 to 120 mA
Current Source Resolution	8 mA
Current Source Accuracy	+/- 4 % +/- 1.0 mA
On Hook Tip to Ring Voltage	38 V typical

Ringling Generator

Level Range (Open Circuit)	1 to 100 Vrms (Superimposed upon DC Bias Voltage)
Level Resolution	1 Volts
Level Accuracy	+/- 5.0% (Level = 20.0 to 100 Vrms, Load = open circuit)
AC Source Impedance	2100 ohms typical

Frequency Range	14.0 to 75.0 Hz
Frequency Resolution	0.1 Hz
Frequency Accuracy	+/- 0.02 Hz +/- 0.1%
Cadence	Up to 3 on/off stages
On Time Range	0 to 10,000 msec
On Time Resolution	25 msec or 50 msec
On Time Accuracy	+/- 0.5%
Off Time Range	0 to 10,000 msec
Off Time Resolution	25 msec or 50 msec
Off Time Accuracy	+/- 0.5%
DC Bias	42 V
Ring Trip DC Current Detection Threshold	12 mA +/- 2 mA

Signaling Tones

Supported Tones	Primary Dial Tone Secondary Dial Tone Busy Ringback
Tone Cadence	3 on/off stages (1 stage for Busy)
On Time Range	0 to 5,000 or 10,000 msec
On Time Resolution	25 msec or 50 msec
On Time Accuracy	+/- 0.5%
Off Time Range	0 to 5,000 or 10,000 msec
Off Time Resolution	25 msec or 50 msec
Off Time Accuracy	+/- 0.5%

Level Range	0 to -50.0 dBm 0 to -40 dBm (dial tone)
Level Resolution	0.1 dB 1 dB (dial tone)
Dial Tone Level Accuracy	+/- 1 dB @ 0 dBm +/- 3 dB @ -35 dBm
Busy and Ring Back Level Accuracy (frequency greater than 400 Hz Gain/Delay = flat)	+/- 0.5 dB @ 0 dBm +/- 0.6 dB @ -40.0 dBm +/- 1.0 dB @ -50.0 dBm
Frequency Range	100.0 to 720.0 Hz
Frequency Resolution	0.1 Hz
Frequency Accuracy	+/- 0.02 Hz +/- 0.1%

Touch Tone Detection Limits

Input Level Range	0.0 to -25.0 dBm
Max. Invalid Tone Duration	20.0 msec
Min. Interdigit Pause	40.0 msec
Max. Acceptable Dropout	20.0 msec

Dial Pulse Detection Limits

Interval Range (Make & Break)	10 to 90 msec
Interval Resolution	1 msec
Interval Accuracy	+/- 5 msec (at 40 mA loop current)
Min. Interdigit Pause	300.0 msec

Telephone Number

Station A	1 to 15 digits
Station B	1 to 15 digits

Switching Delay

Range	1 to 25,000 msec
Resolution	1.0 msec
Accuracy	+/- 0.05% + call processing delay

Dial Tone (Off Hook) Delay

Range	2 to 25,000 msec
Resolution	1.0 msec
Accuracy	+/- 0.05% + call processing delay

On Hook Delay

Range	1 to 255 msec
Resolution	1.0 msec
Accuracy	+/- 0.05% + call processing delay

Disconnect Signalling

Signal Options	No Signal Busy Tone Dial Tone
Range	1 to 30,000 msec (relative to On Hook Delay)
Resolution	1.0 msec
Accuracy	+/- 0.05% +/- 1.0 msec

Call Processing Delay

Minimum	5 msec
Typical	7 msec
Maximum	10 msec

7.7. Interfaces

Station Set Interfaces

(Type RJ45S jacks located on front and terminal strip located on rear)

Pin Assignments:

4W configuration

Pin 1: Transmit Signal (R1 - Input to Emulator)
Pin 2: Transmit Signal (T1 - Input to Emulator)
Pin 3: TEK5 Loopback Mode Indicator
Pin 4: No Connect
Pin 5: No Connect
Pin 6: TEK6 Loopback Mode Indicator
Pin 7: Receive Signal (T - Output from Emulator)
Pin 8: Receive Signal (R - Output from Emulator)

Pin Assignments:

2W configuration

Pin 1: No Connect
Pin 2: No Connect
Pin 3: No Connect
Pin 4: Ring
Pin 5: Tip
Pin 6: No Connect
Pin 7: Program Resistor (866 ohms)
Pin 8: Program Resistor (866 ohms)

External A->B and B -> A Path Breakout Interfaces (2-Wire Modes Only)

Pin 1, T1: A->B Output
Pin 2, R1: A->B Output
Pin 3, T2: A->B Input
Pin 4, R2: A->B Input
Pin 5, T1: B->A Output
Pin 6, R1: B->A Output
Pin 7, T2: B->A Input
Pin 8, R2: B->A Input

Hybrid Balance Network Interface (2-Wire Modes Only)

Pin A1: Node 1 of Station A Network
Pin A2: Node 2 of Station A Network
Pin B1: Node 1 of Station B Network
Pin B2: Node 2 of Station B Network

Loop Emulator Interface

(Type RJ45 jacks located on rear)

Pin Assignments:
2W configuration
for NI (Network Interface)
Connectors

Pin 1: No Connect
Pin 2: No Connect
Pin 3: No Connect
Pin 4: Ring (to NI end of loop)
Pin 5: Tip (to NI end of loop)
Pin 6: No Connect
Pin 7: No Connect
Pin 8: No Connect

Pin Assignments:
2W configuration
for EO (Network Interface)
Connectors

Pin 1: No Connect
Pin 2: No Connect
Pin 3: No Connect
Pin 4: Ring (to EO end of loop)
Pin 5: Tip (to EO end of loop)
Pin 6: No Connect
Pin 7: No Connect
Pin 8: No Connect

Remote Control Interfaces

RS-232C (DTE) Control Port Pin Assignments

Bit Rates	1200, 2400, 4800, or 9600 bps
Mode	asynchronous (CR/LF or ACK/NAK)
Word Length	7 or 8 bits
Parity	odd, even, none
Stop Bits	1, 1.5, 2

7.8. Gain and Delay Distortion Characteristics

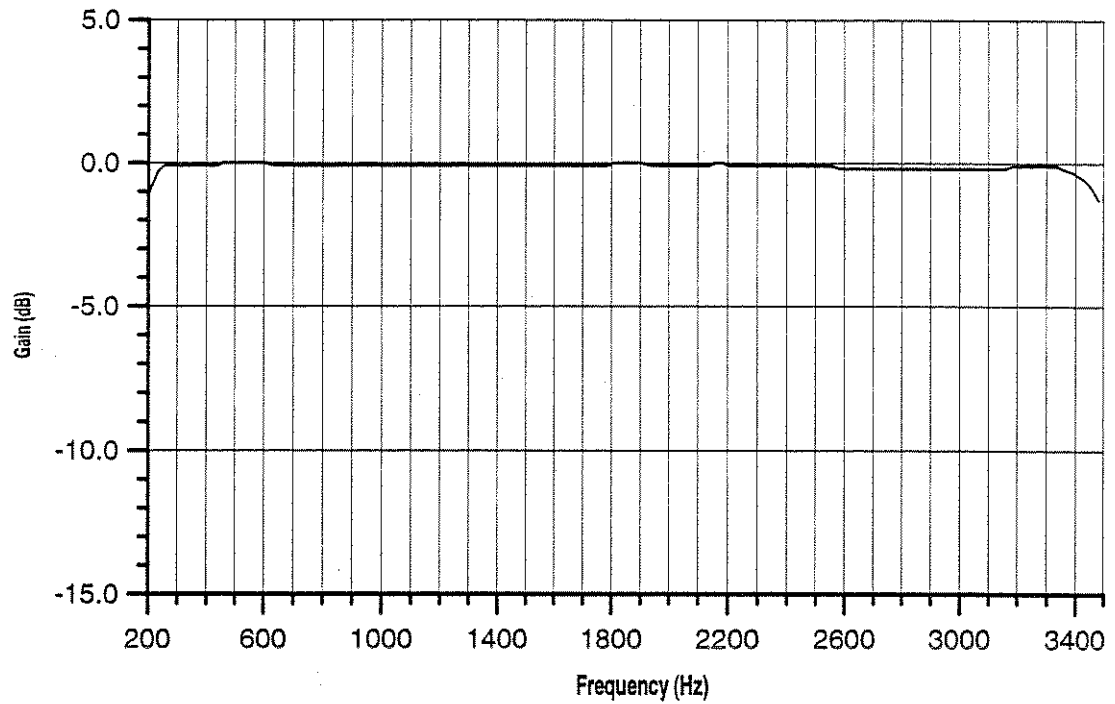

Figure 7-1. TAS Flat Gain

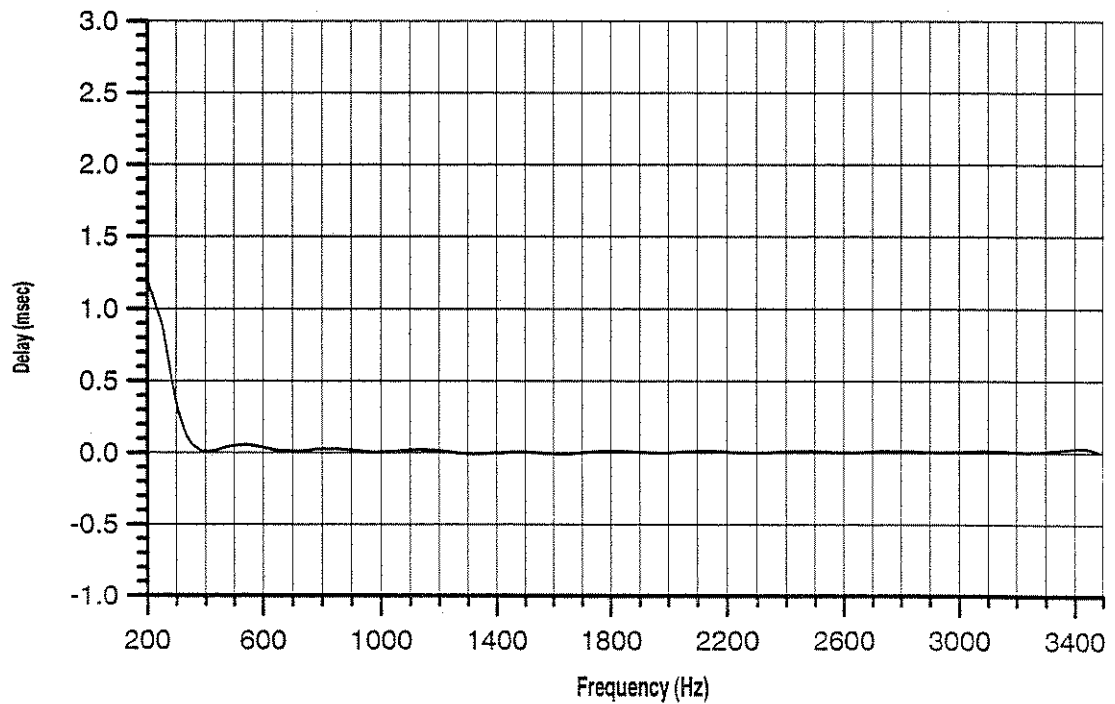

Figure 7-2. TAS Flat Delay

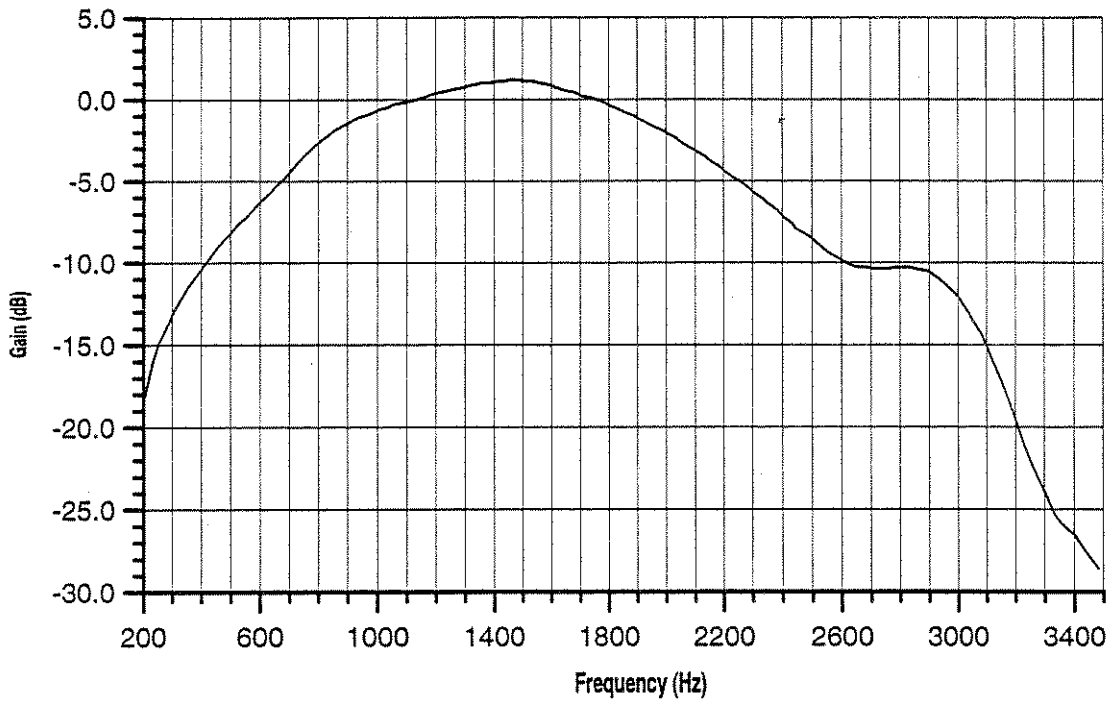

Figure 7-3. TAS Seg FA-1445 Emulation (Seg 3002) Gain

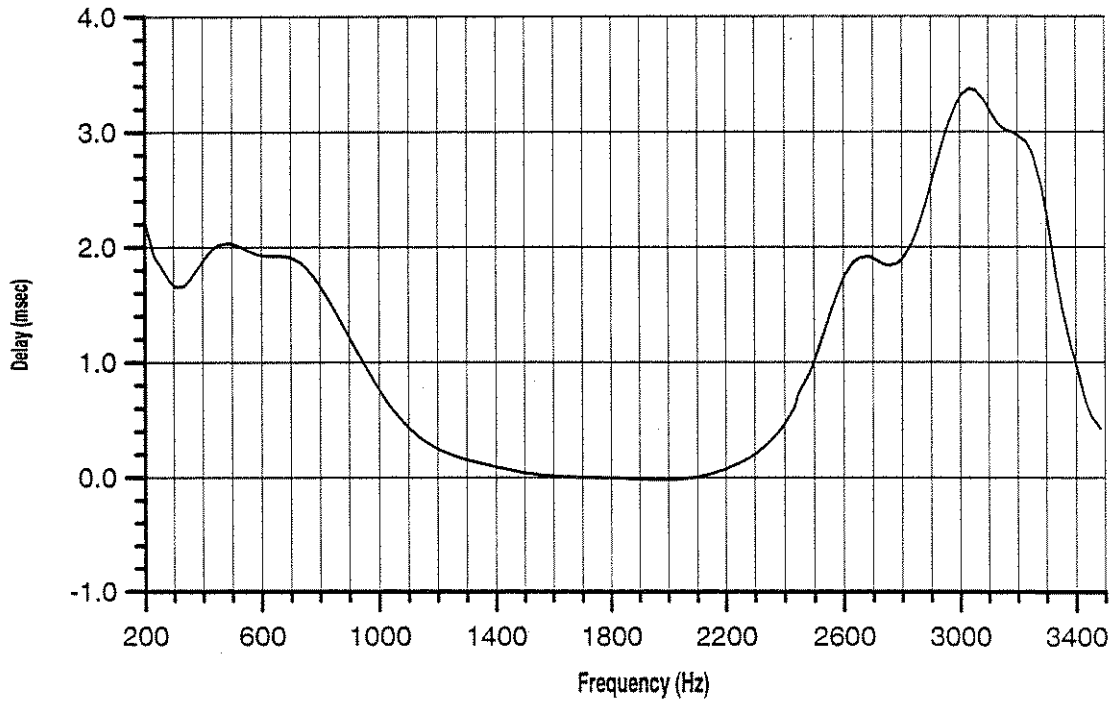

Figure 7-4. TAS Seg FA-1445 Emulation (Seg 3002) Delay

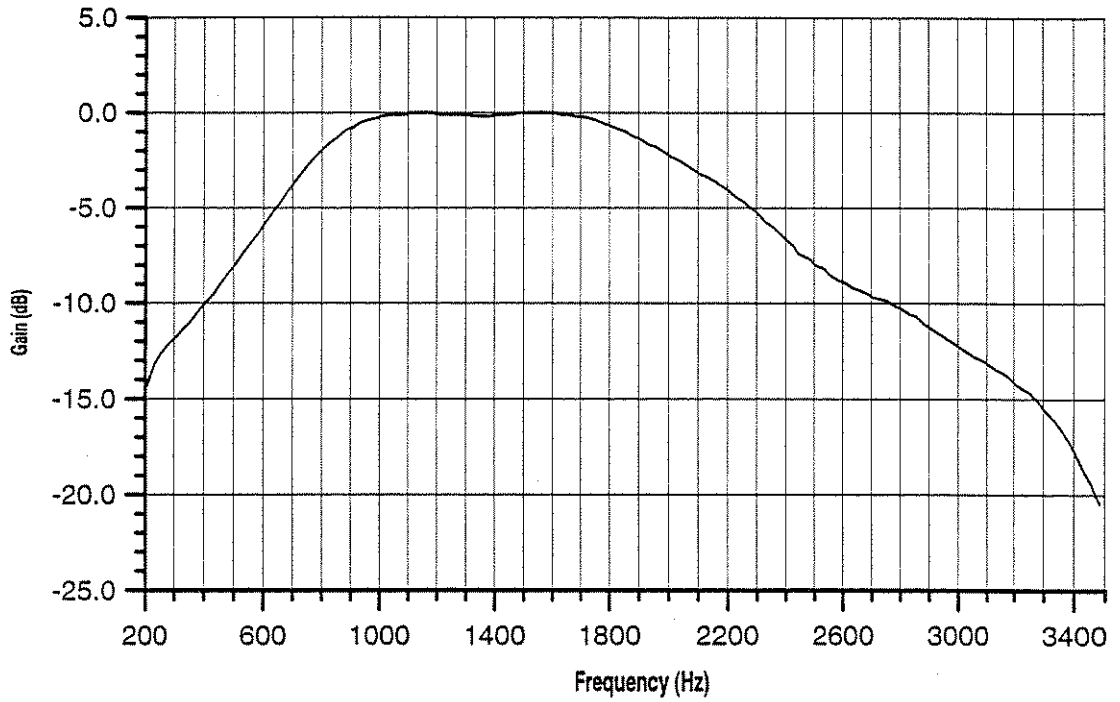

Figure 7-5. TAS "Worst Case" Bell 3002 Gain

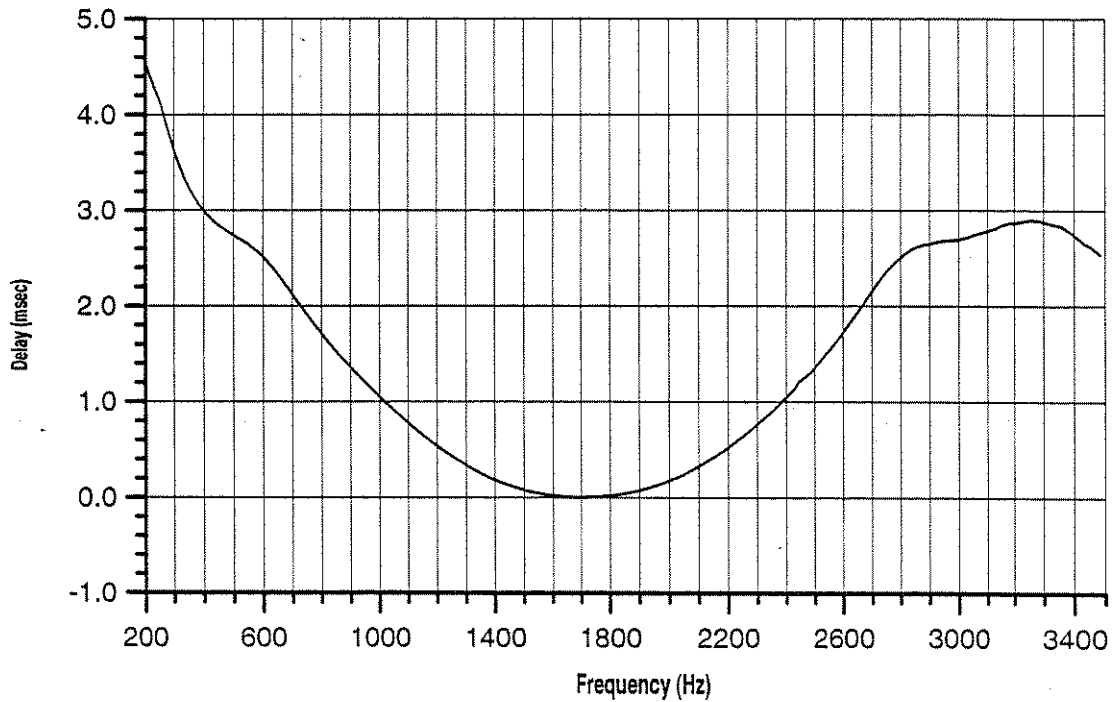

Figure 7-6. TAS "Worst Case" Bell 3002 Delay

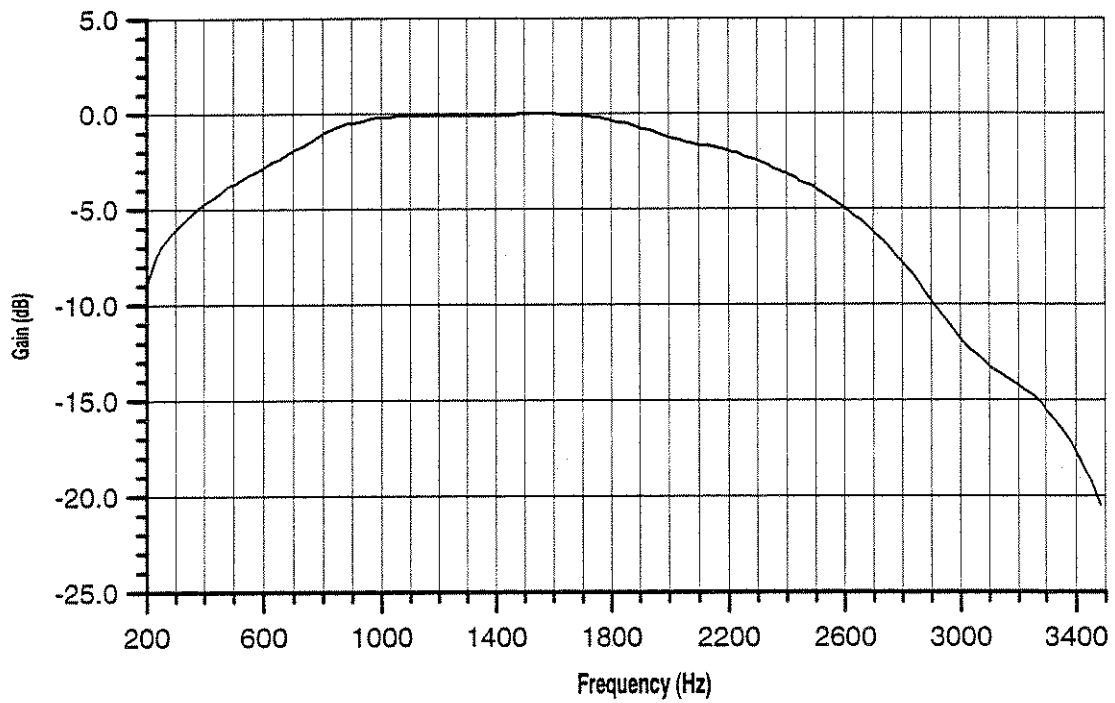

Figure 7-7. TAS "Worst Case" Bell C1 Gain

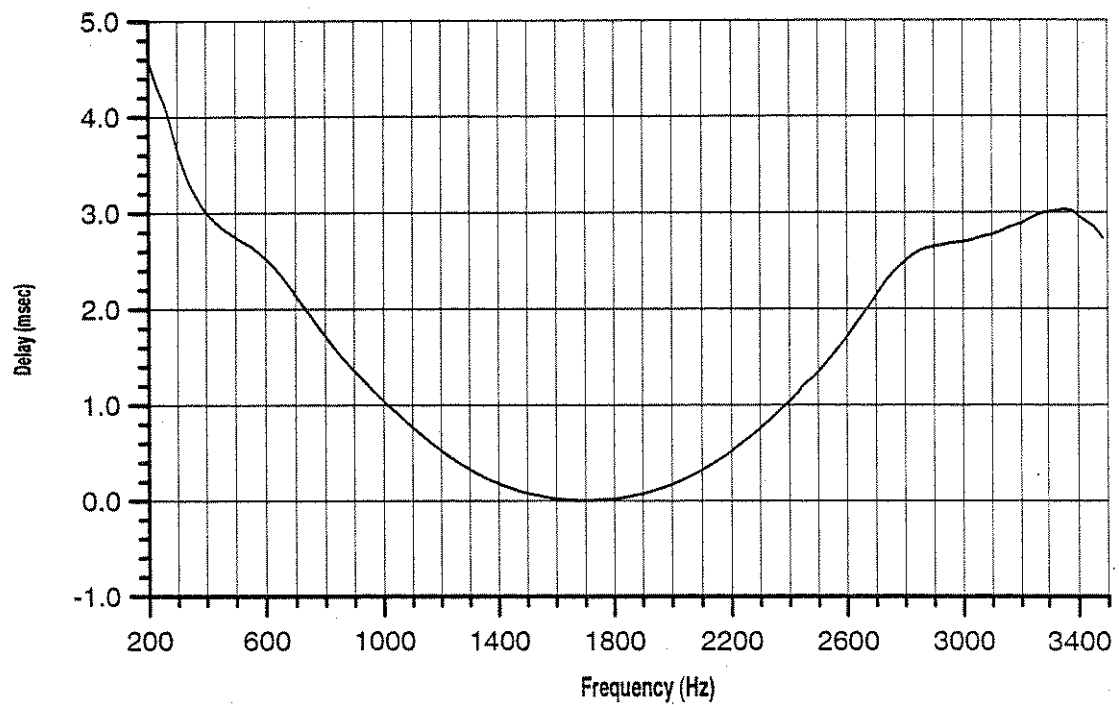

Figure 7-8. TAS "Worst Case" Bell C1 Delay

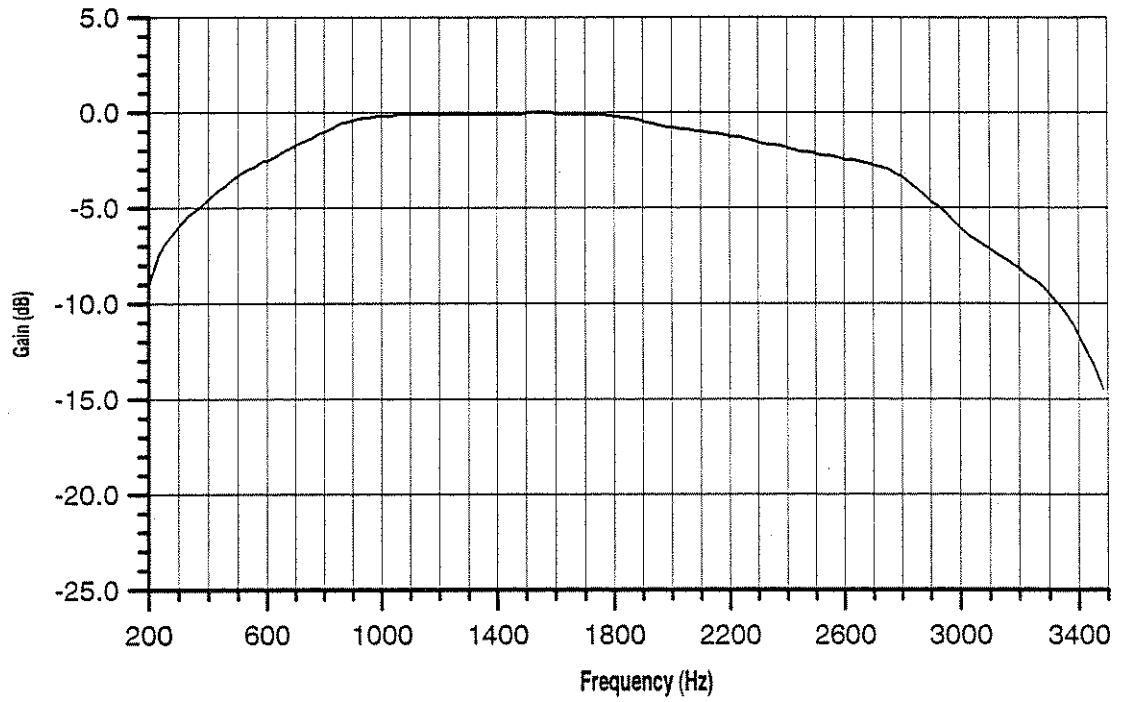

Figure 7-9. TAS "Worst Case" Bell C2 Gain

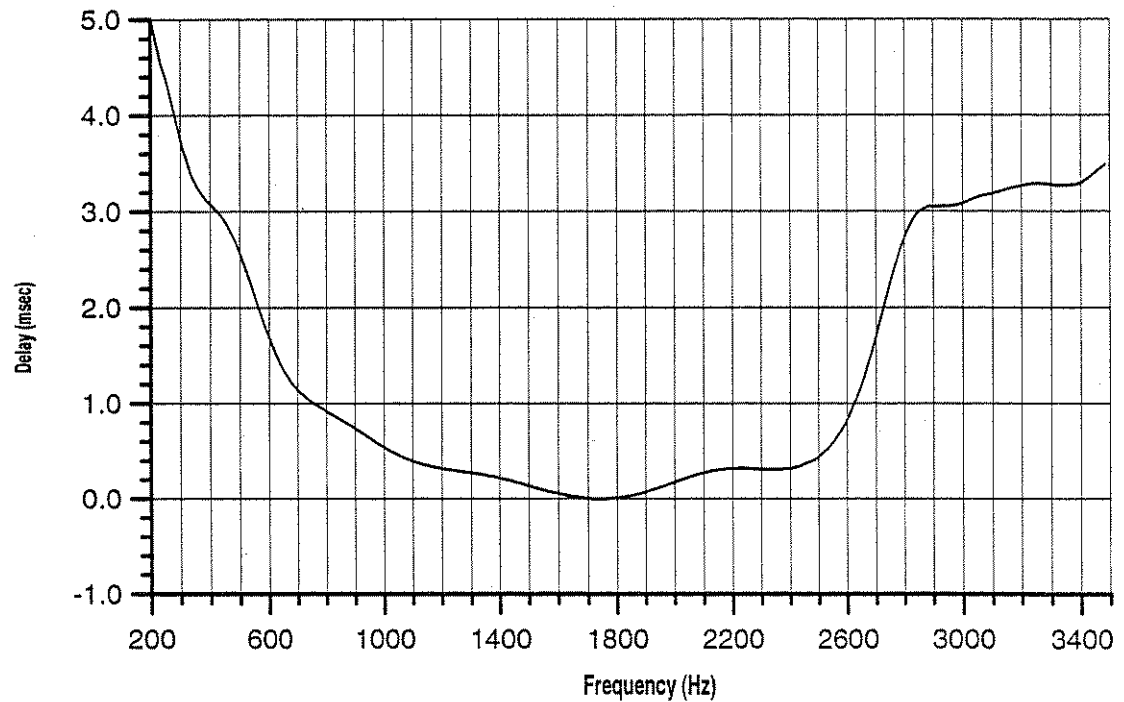

Figure 7-10. TAS "Worst Case" Bell C2 Delay

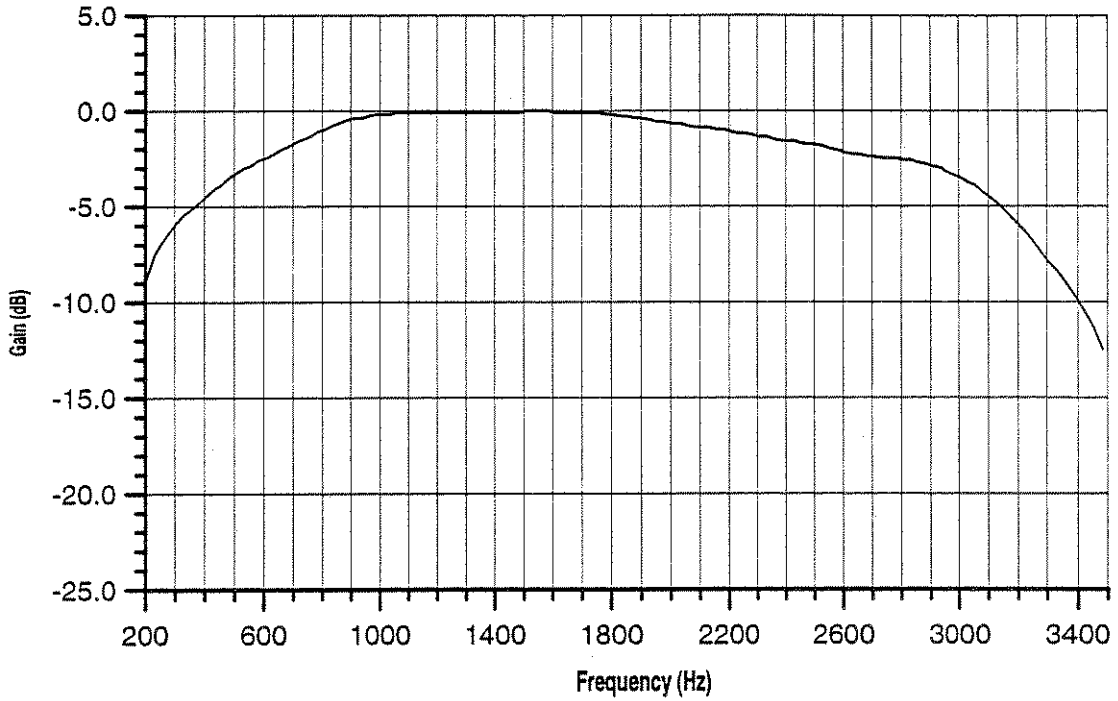

Figure 7-11. TAS "Worst Case" Bell C4 Gain

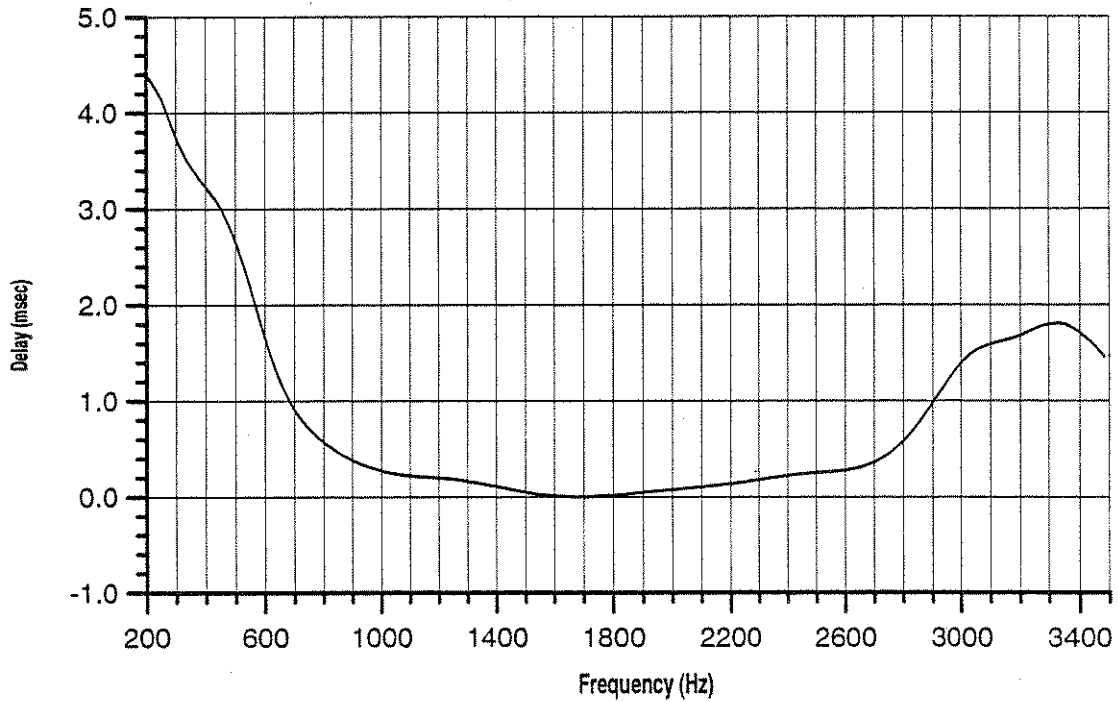

Figure 7-12. TAS "Worst Case" Bell C4 Delay

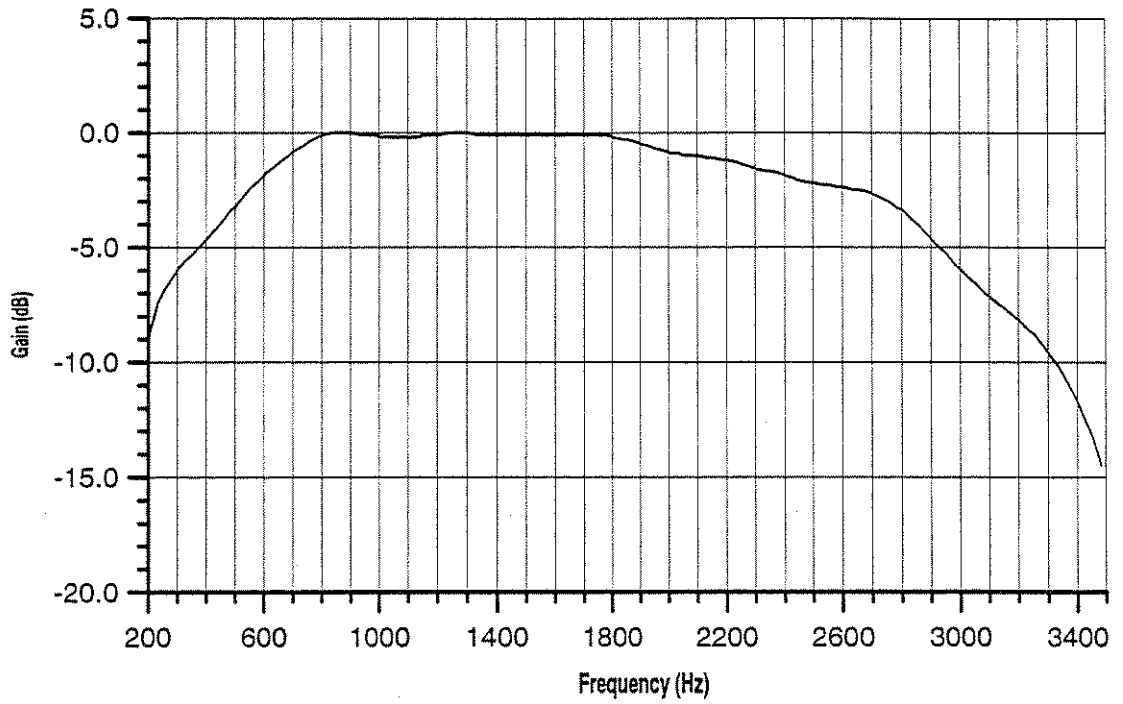

Figure 7-13. TAS "Worst Case" CCITT M1020 Gain

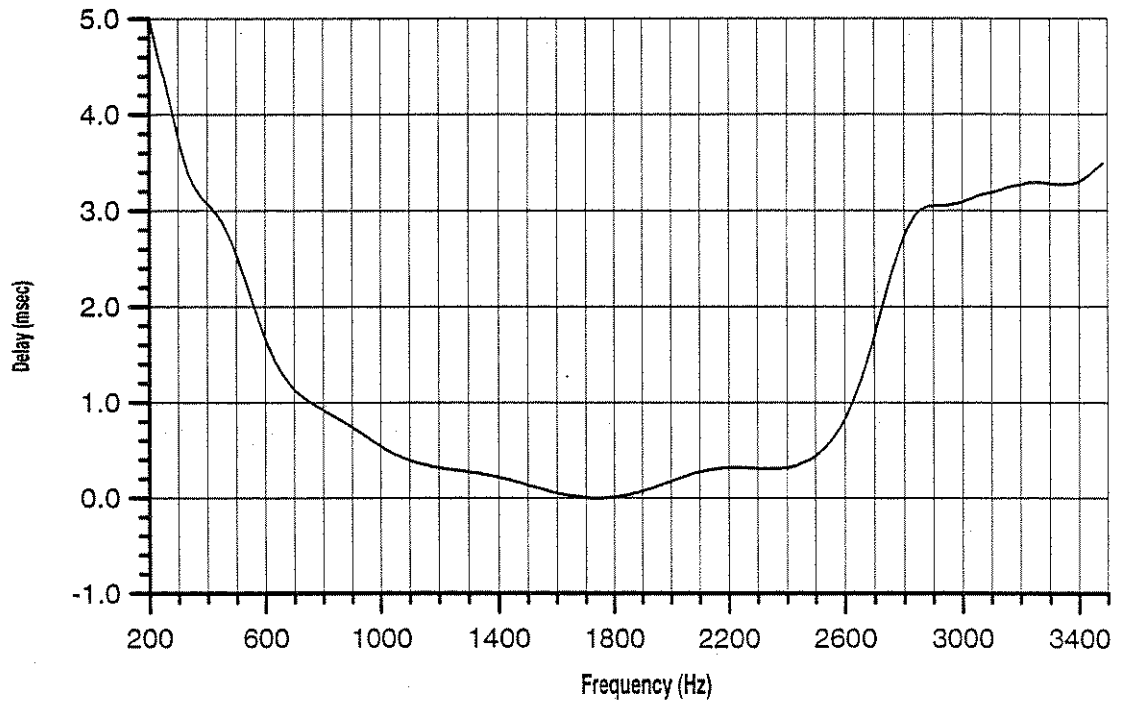

Figure 7-14. TAS "Worst Case" CCITT M1020 Delay

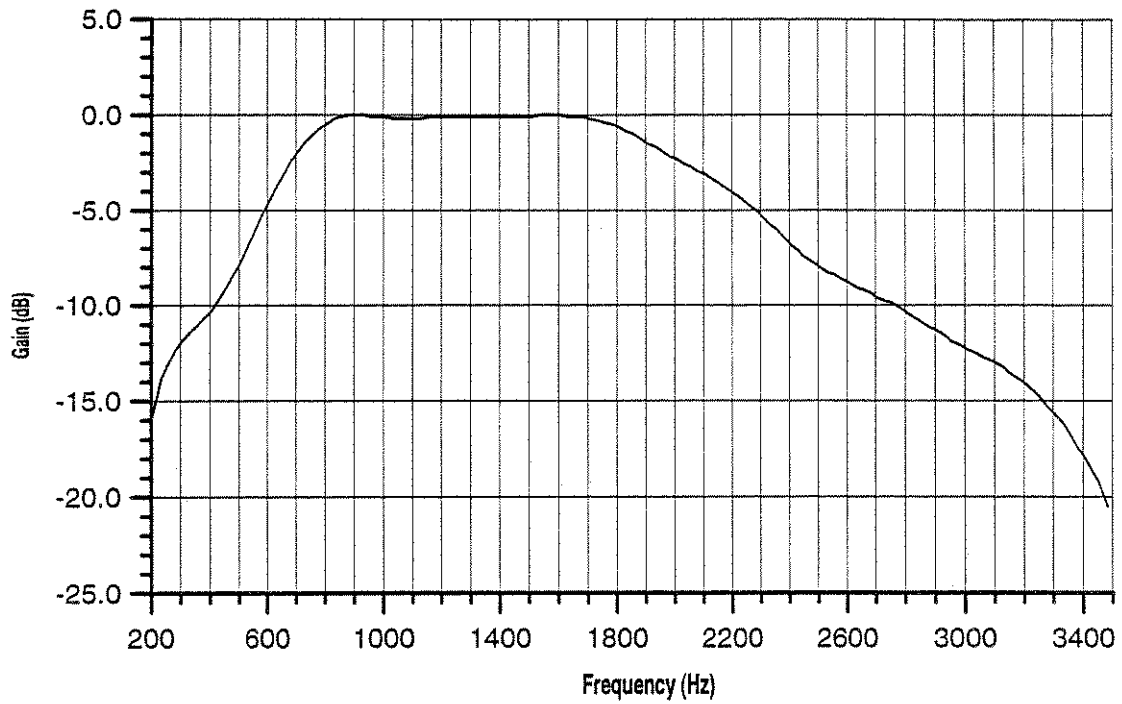

Figure 7-15. TAS "Worst Case" CCITT M1025 Gain

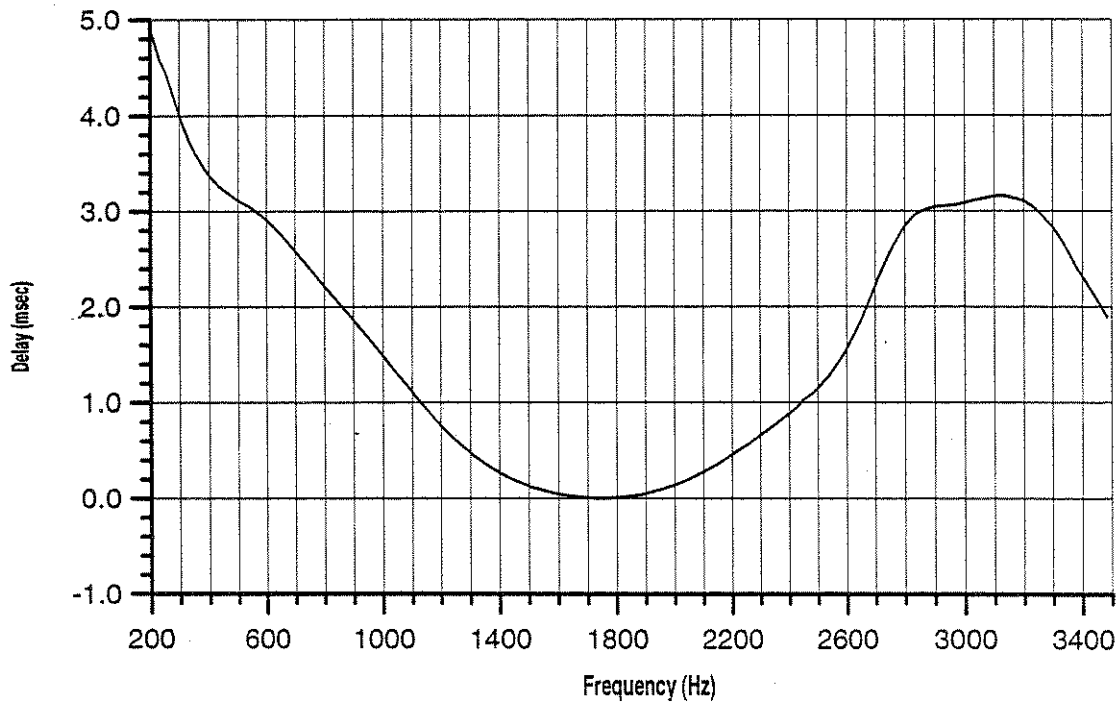

Figure 7-16. TAS "Worst Case" CCITT M1025 Delay

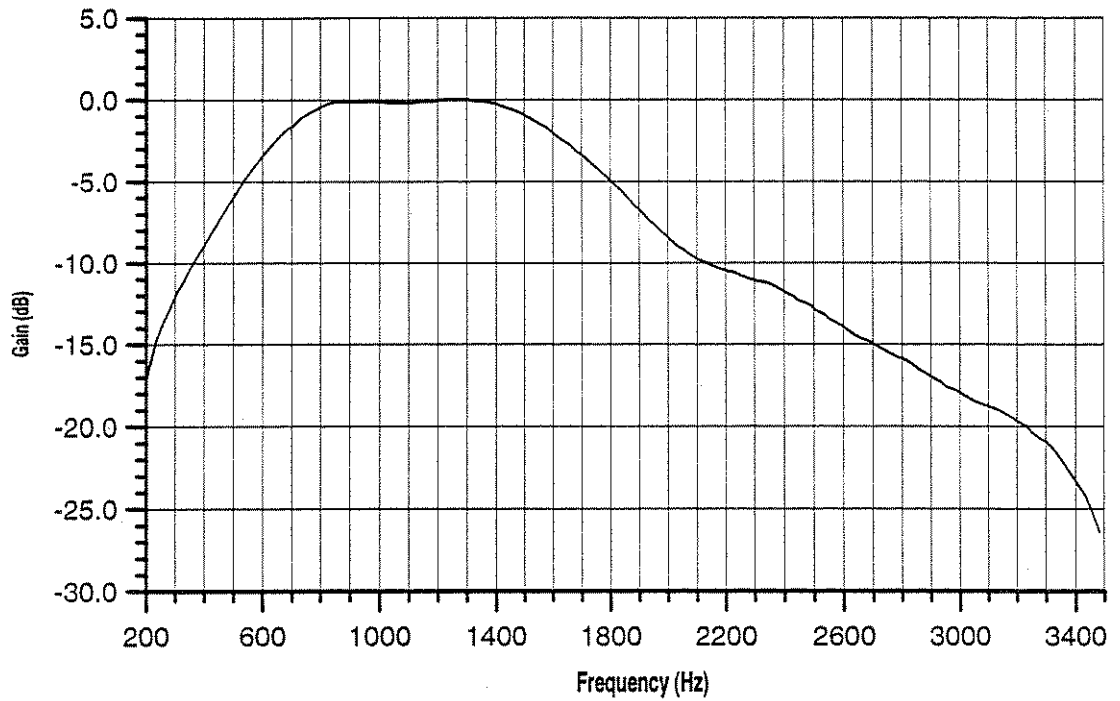

Figure 7-17. TAS "Worst Case" CCITT M1040 Gain

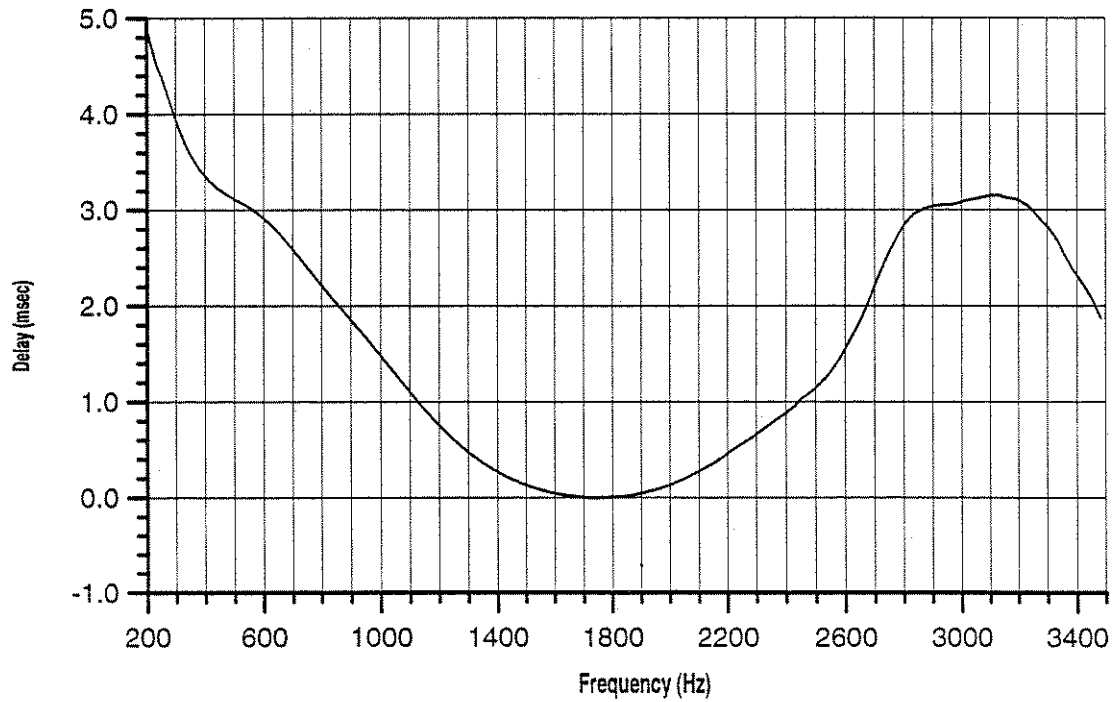

Figure 7-18. TAS "Worst Case" CCITT M1040 Delay

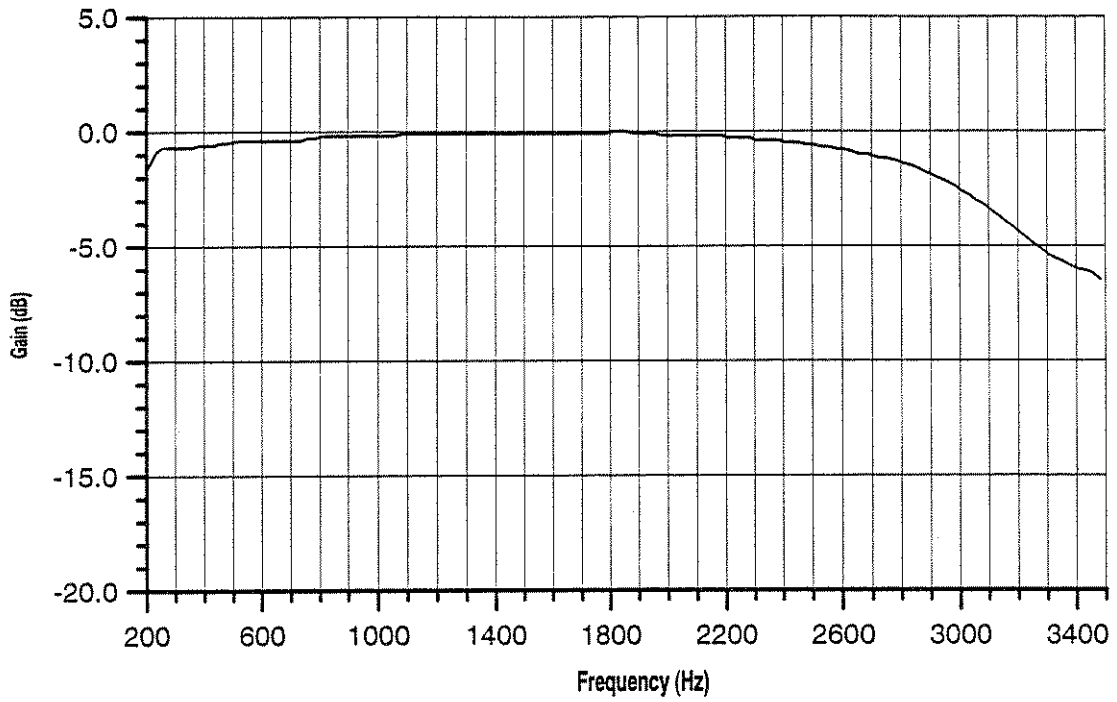

Figure 7-19. TAS EIA A Gain Characteristic

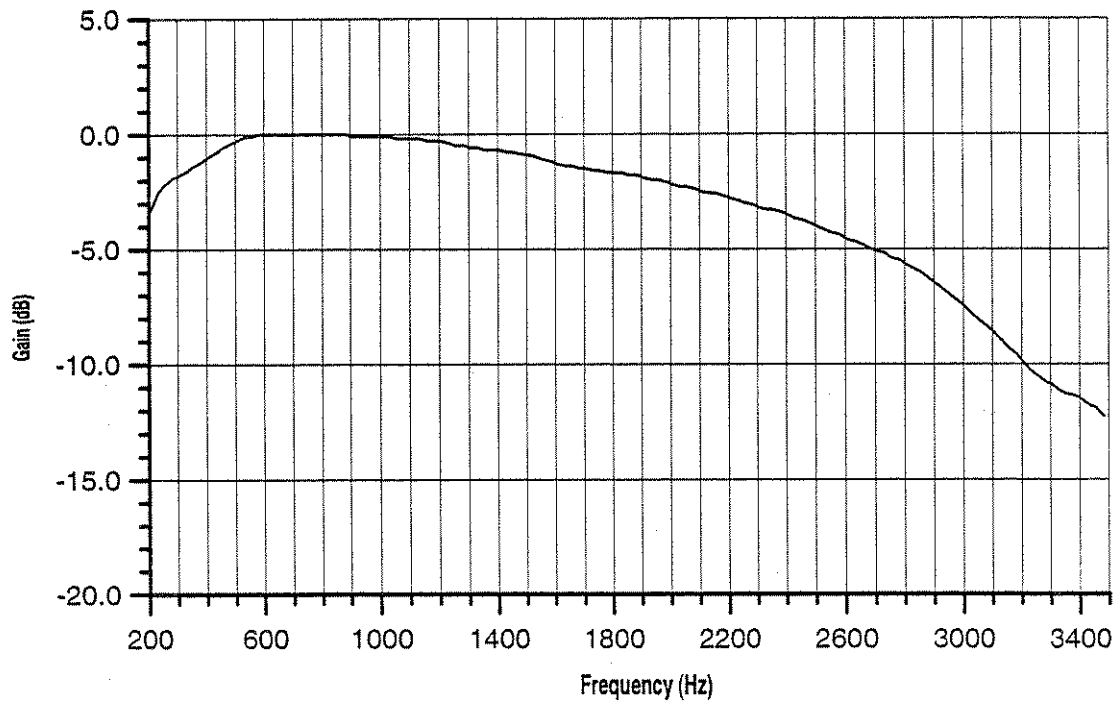

Figure 7-20. TAS EIA B Gain Characteristic

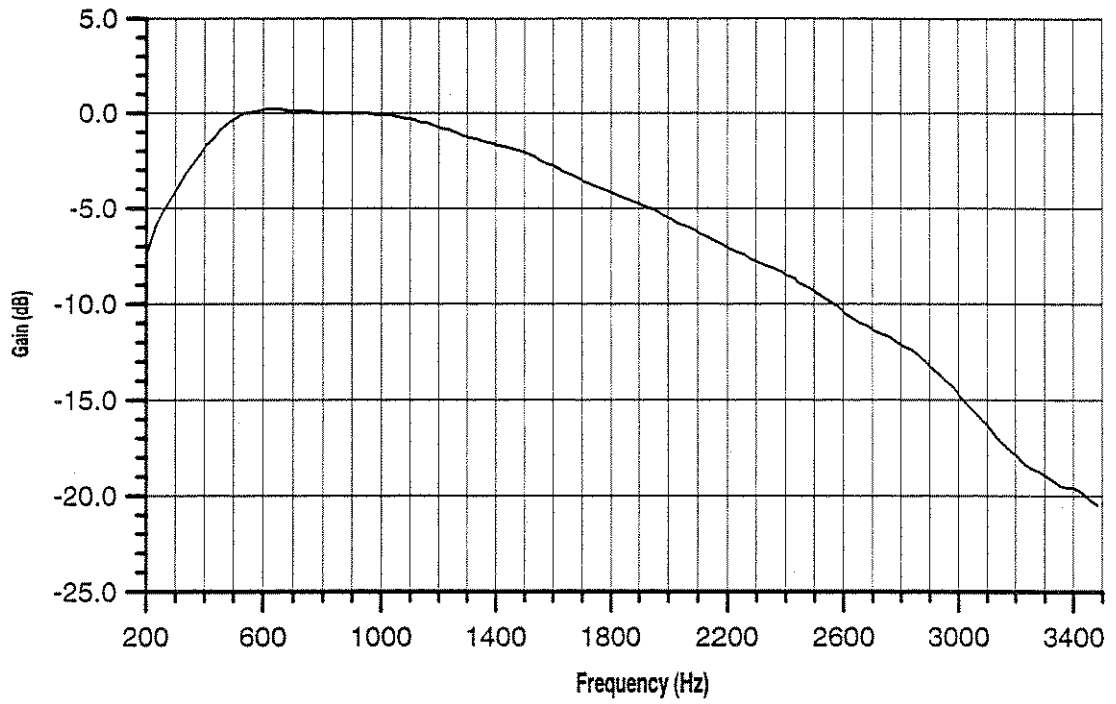

Figure 7-21. TAS EIA C Gain Characteristic

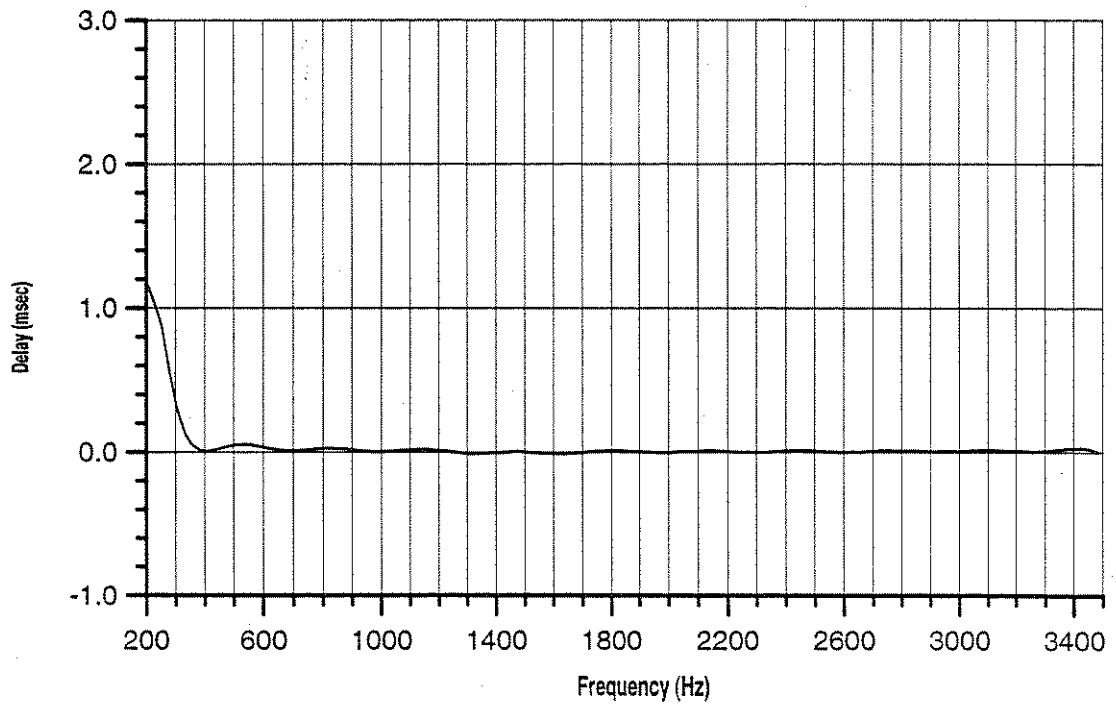

Figure 7-22. TAS EIA 1 Delay Characteristic

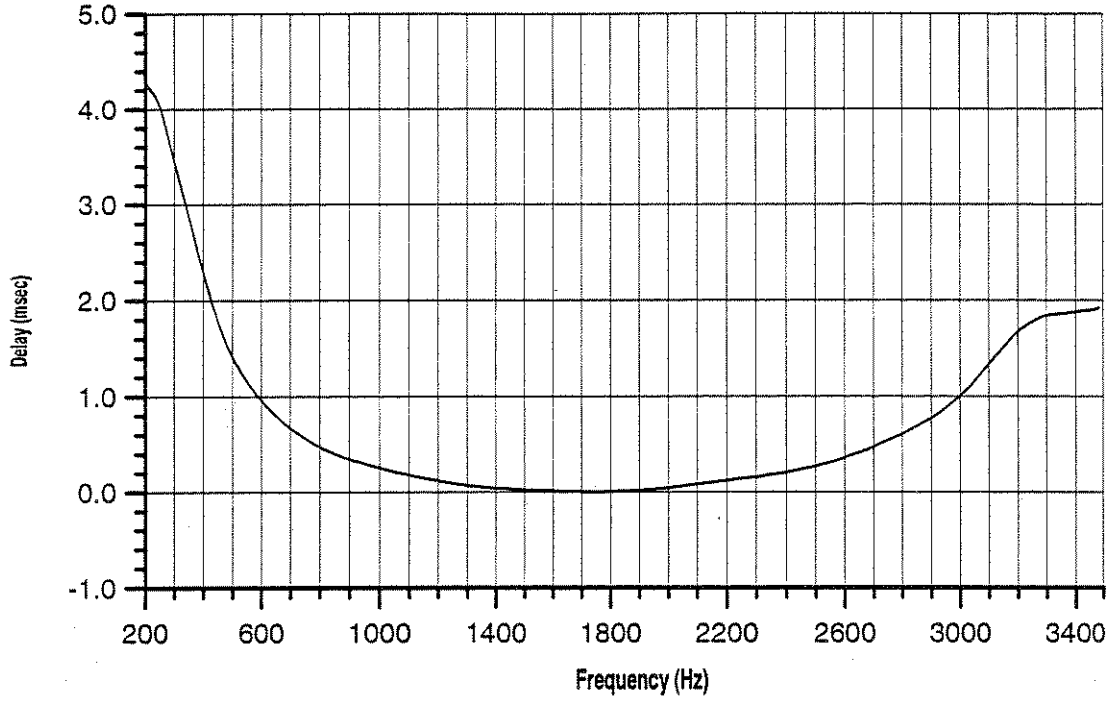

Figure 7-23. TAS EIA 2 Delay Characteristic

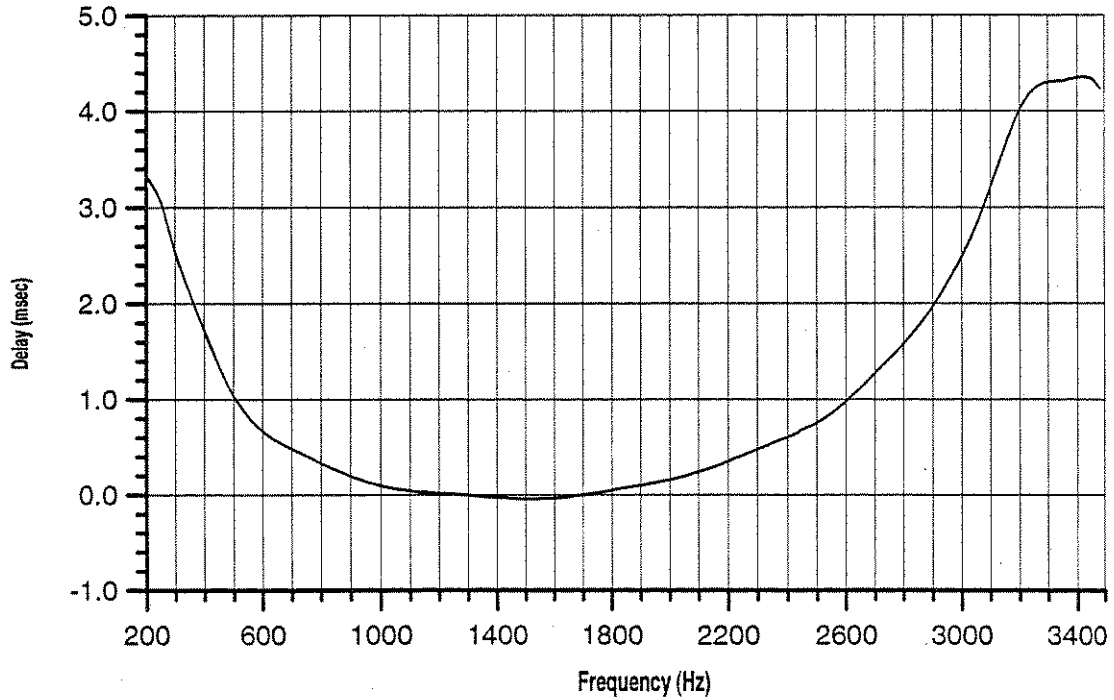

Figure 7-24. TAS EIA 3 Delay Characteristic

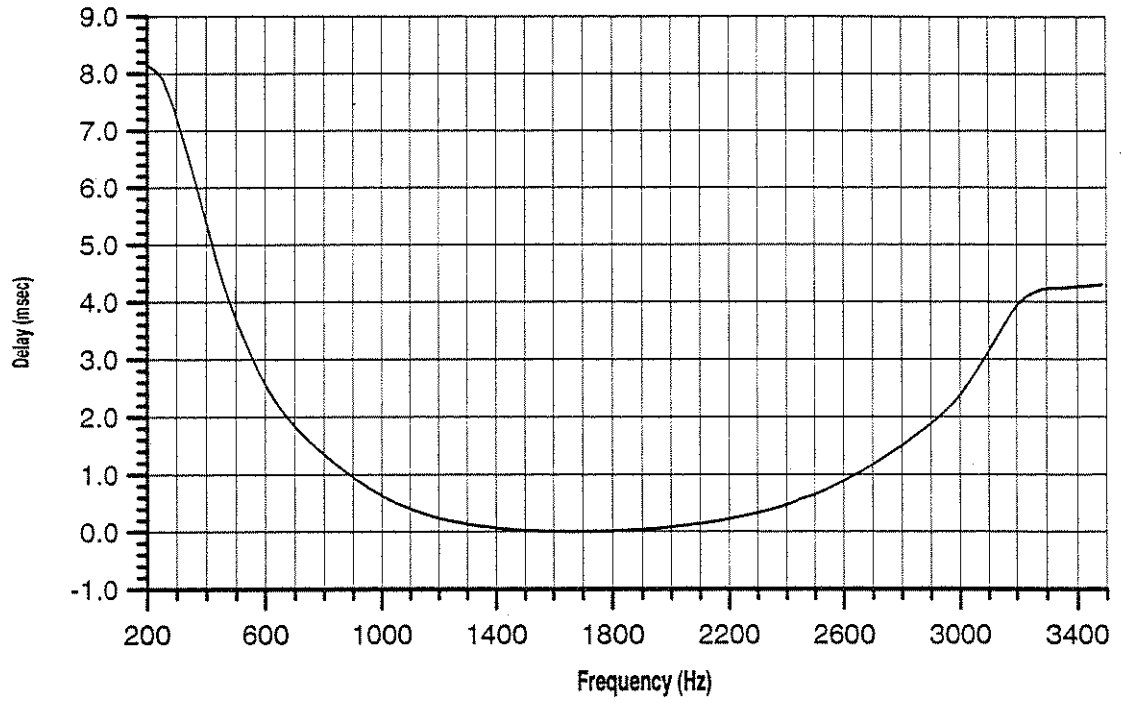

Figure 7-25. TAS EIA 4 Delay Characteristic

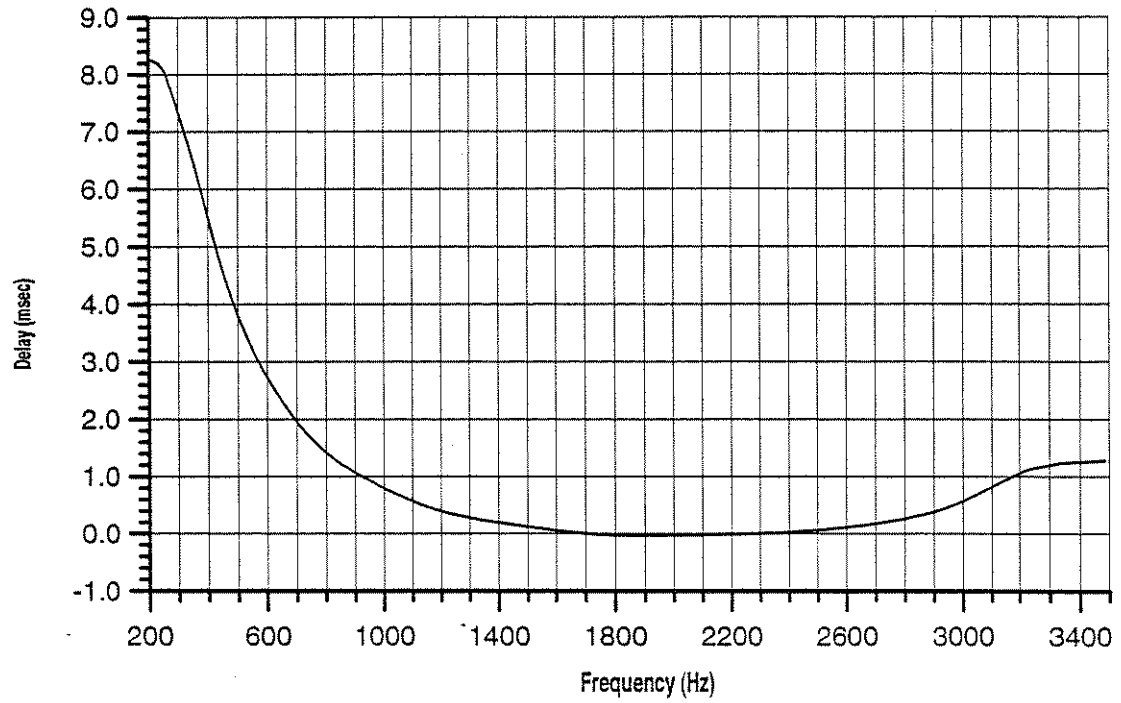

Figure 7-26. TAS EIA 5 Delay Characteristic

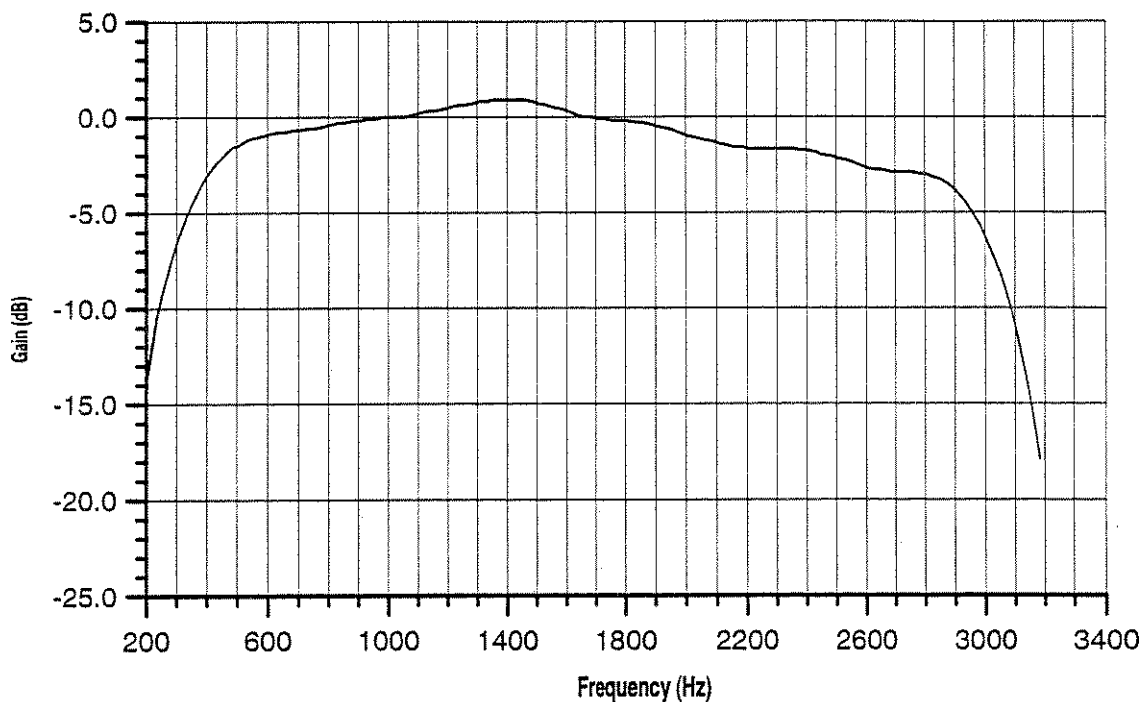

Figure 7-27. TAS "CONUS Mid Data" Gain

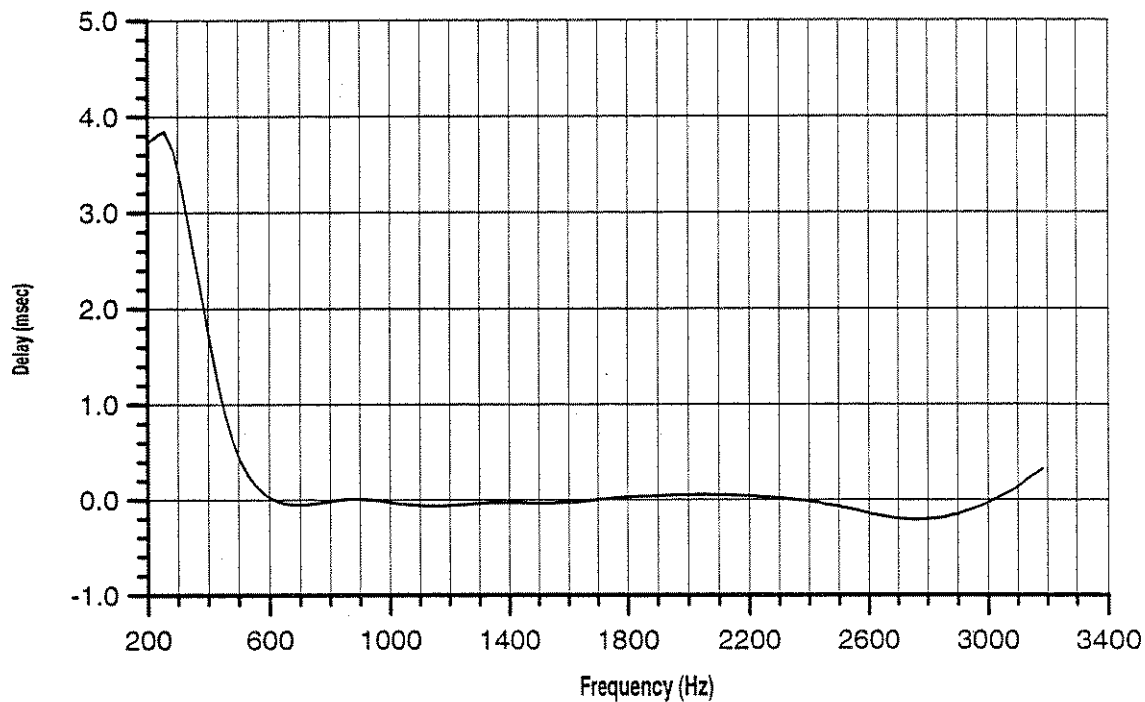

Figure 7-28. TAS "CONUS Mid Data" Delay

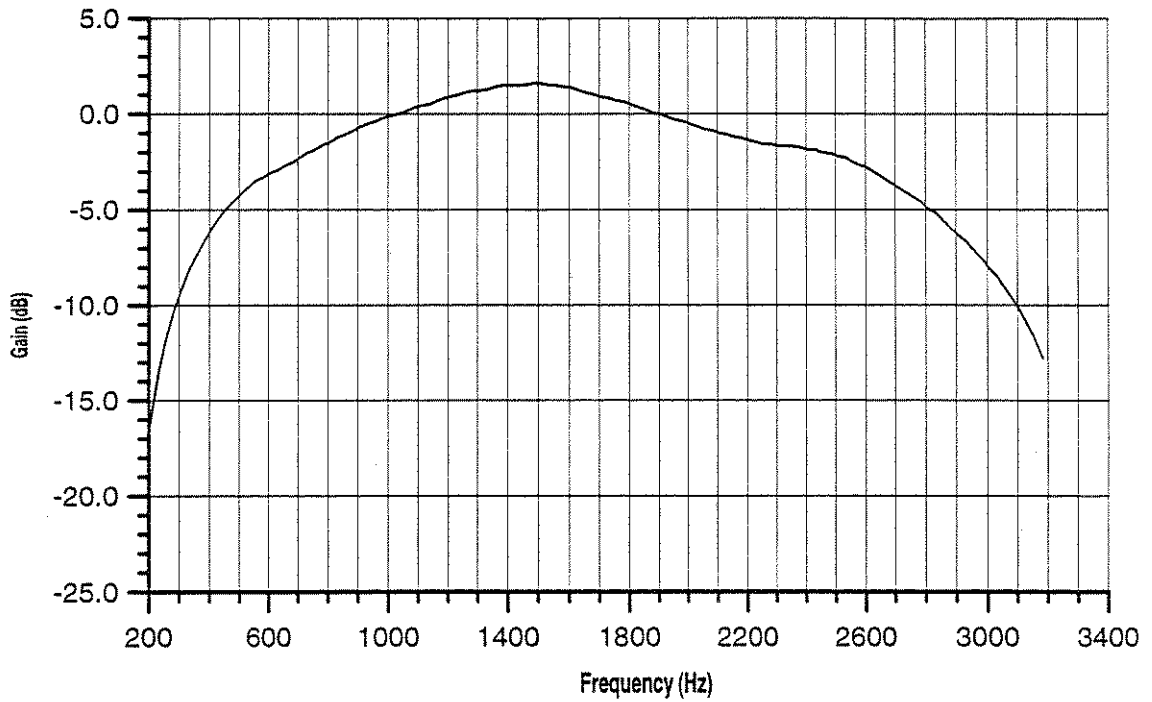

Figure 7-29. TAS "CONUS Mid Voice" Gain

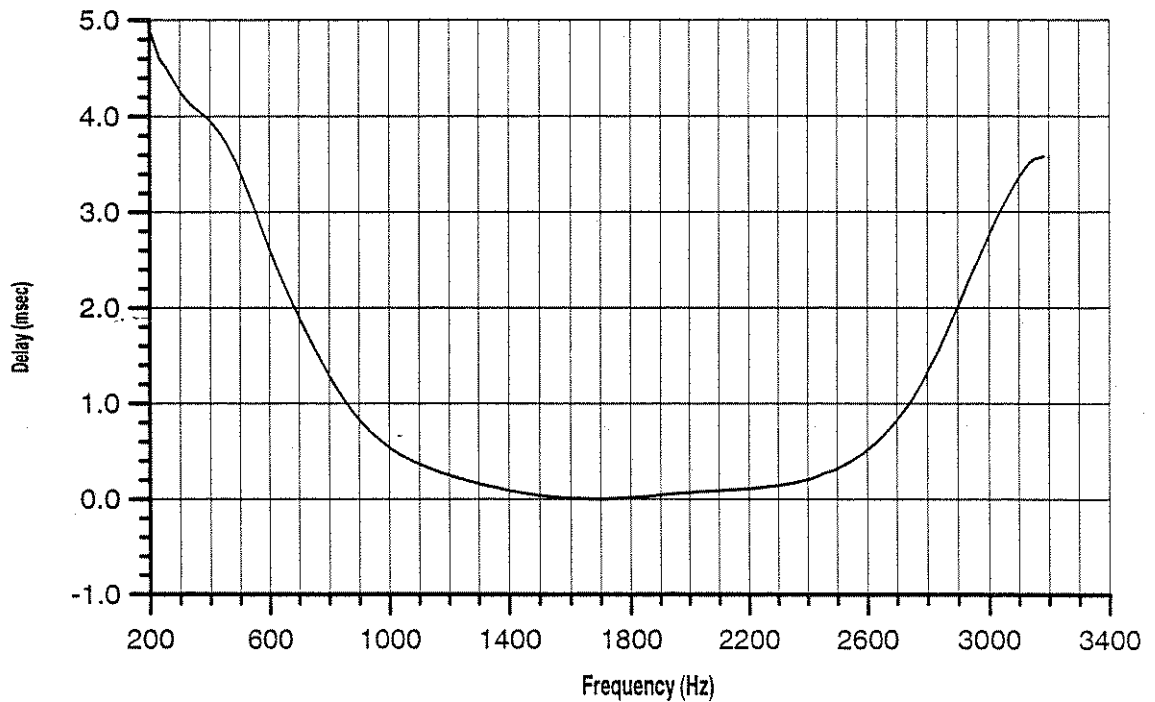

Figure 7-30. TAS "CONUS Mid Voice" Delay

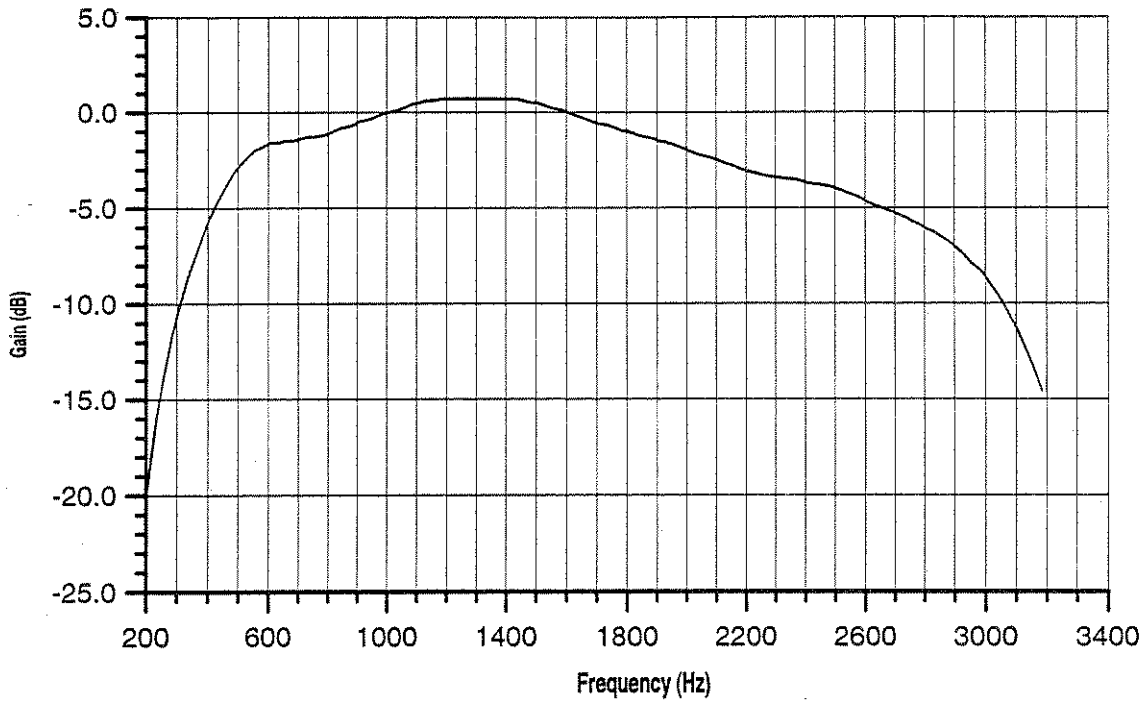

Figure 7-31. TAS "CONUS Poor Data" Gain

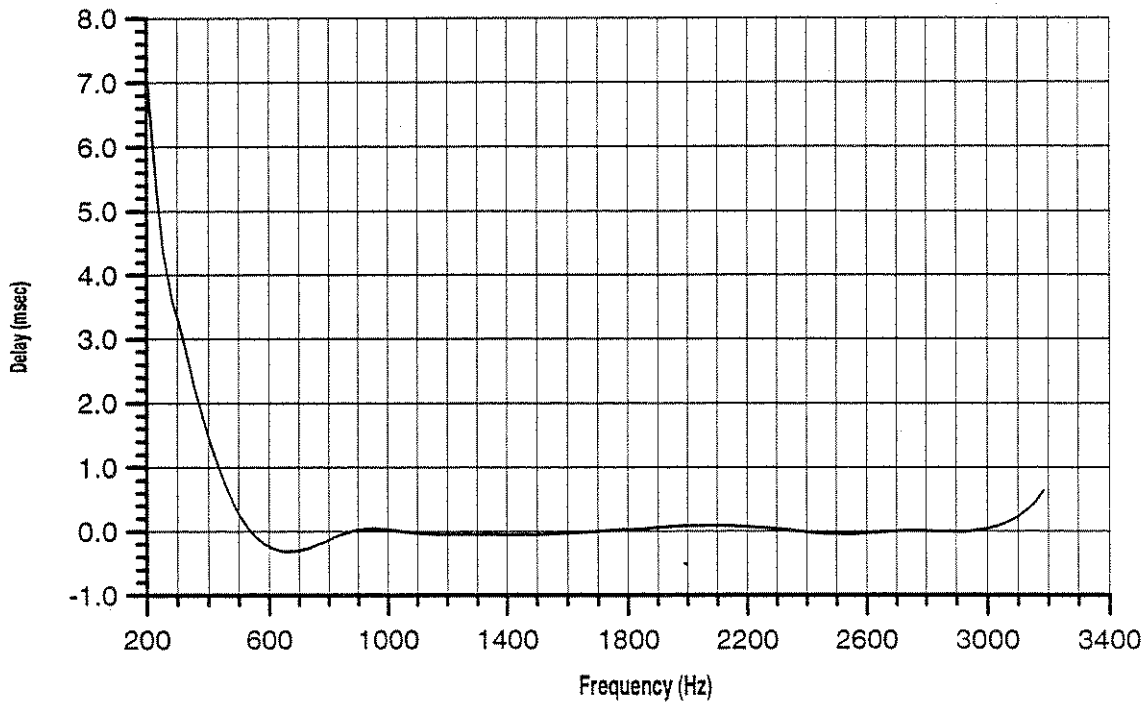

Figure 7-32. TAS "CONUS Poor Data" Delay

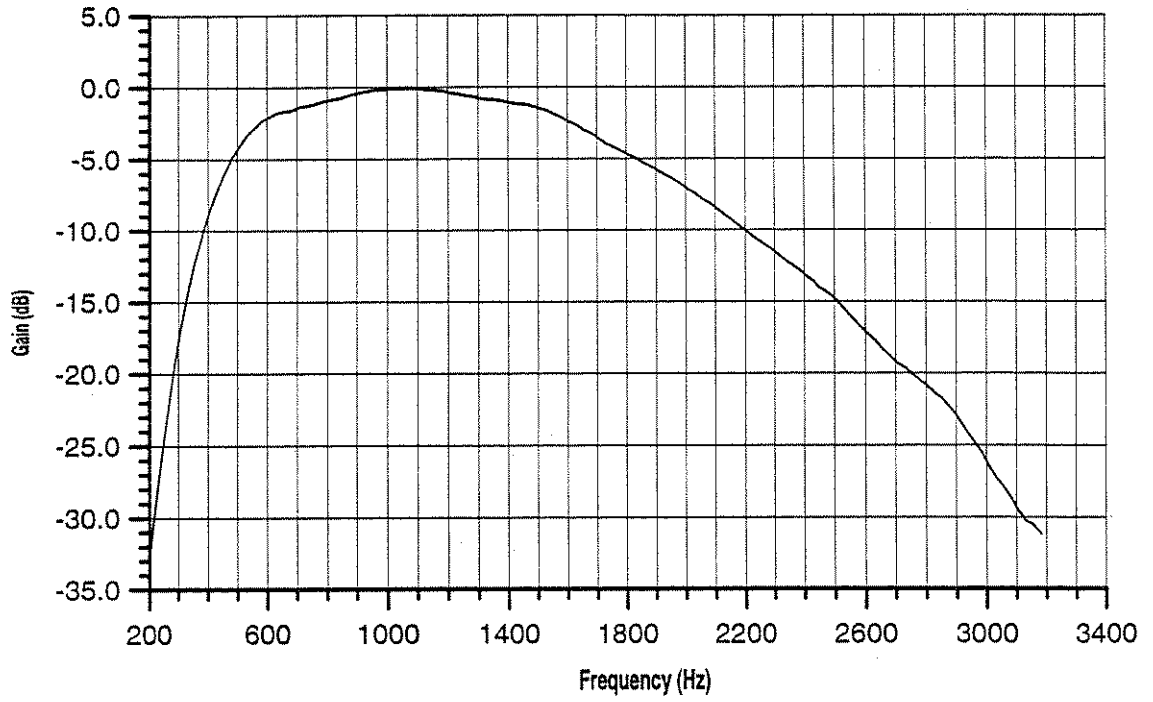

Figure 7-33. TAS "CONUS Poor Voice" Gain

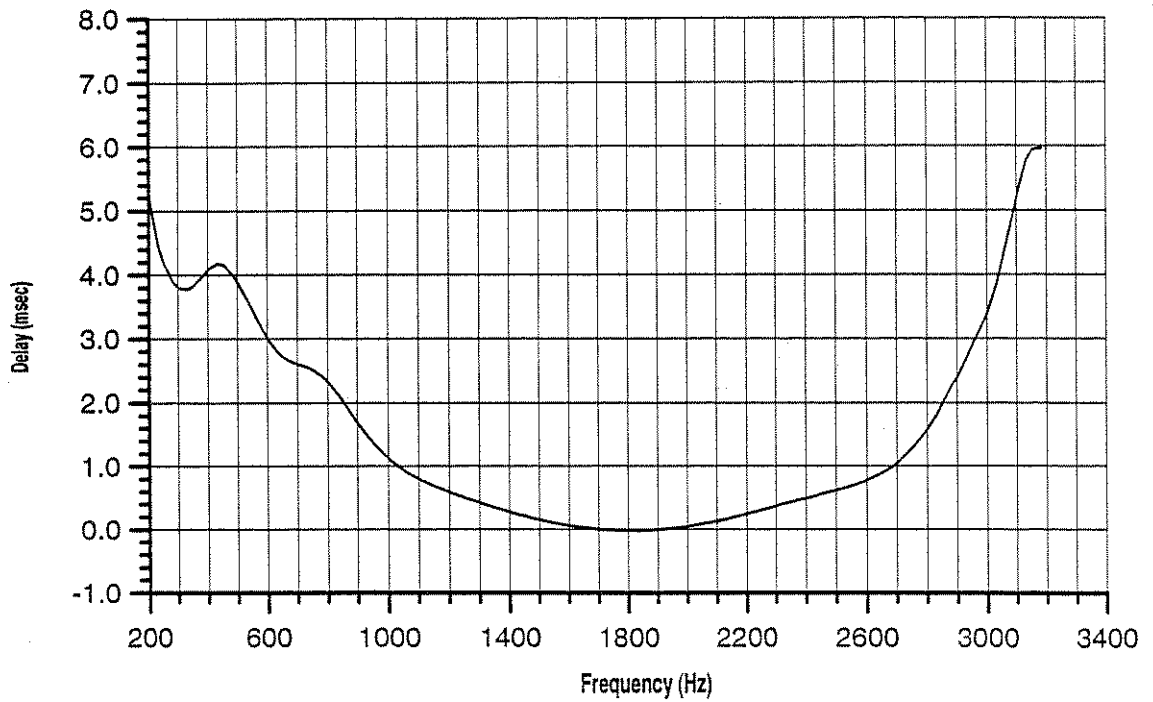

Figure 7-34. TAS "CONUS Poor Voice" Delay

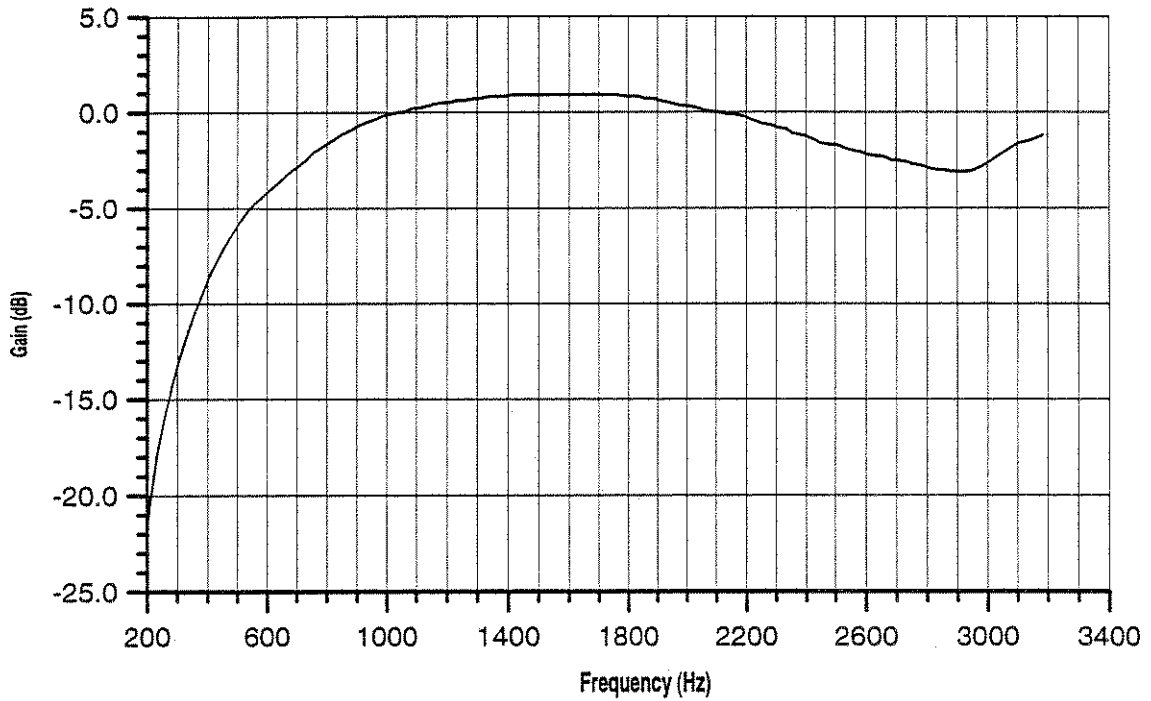

Figure 7-35. TAS "European Mid Data" Gain

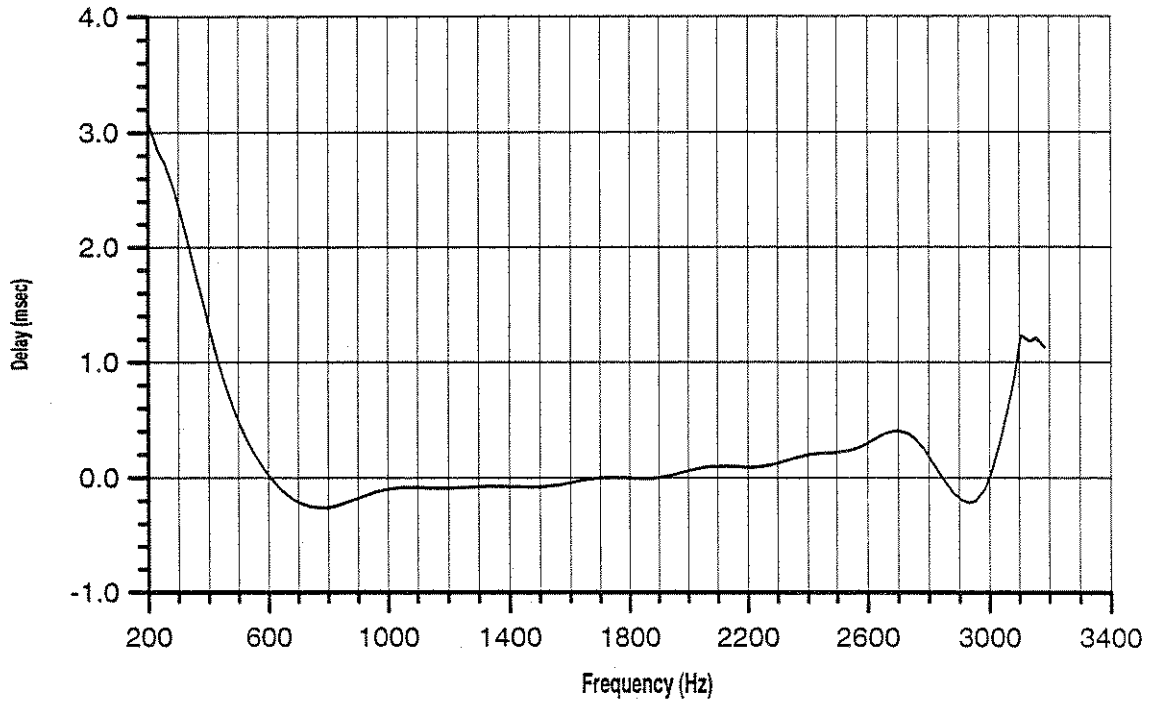

Figure 7-36. TAS "European Mid Data" Delay

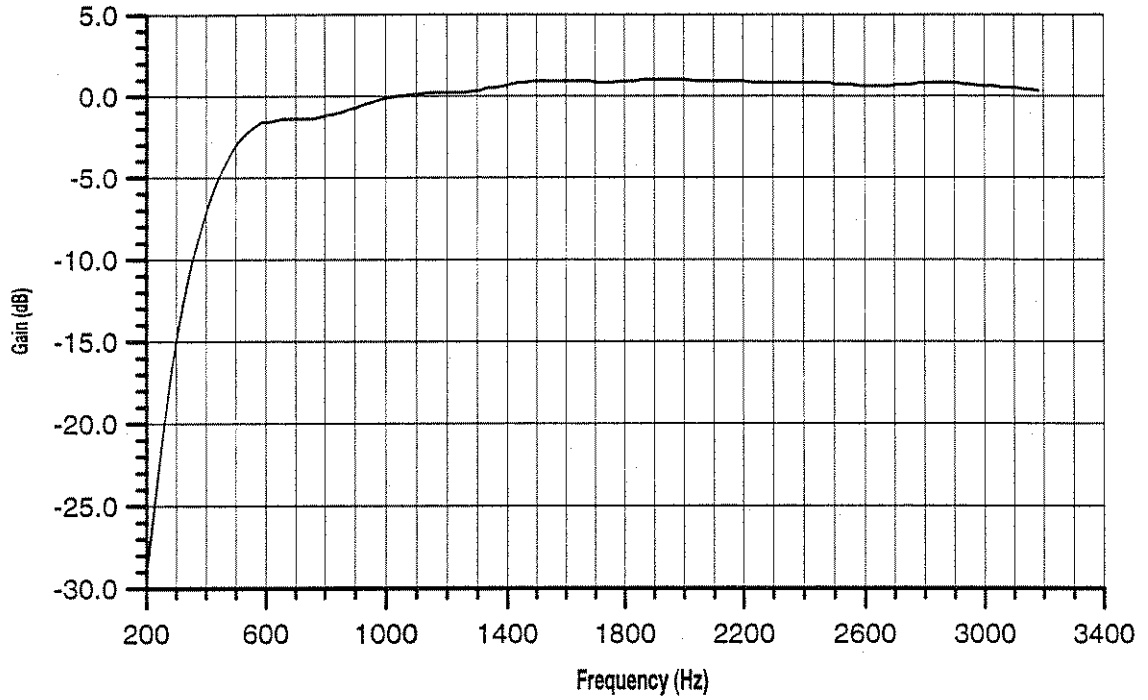

Figure 7-37. TAS "European Mid Voice" Gain

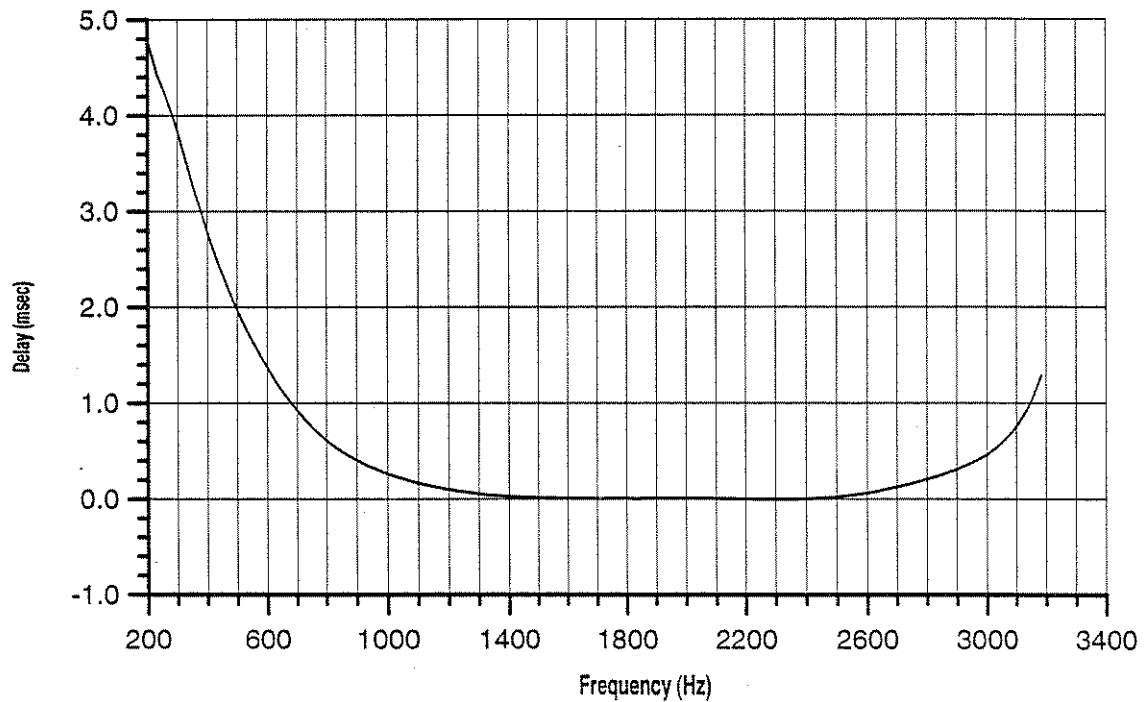

Figure 7-38. TAS "European Mid Voice" Delay

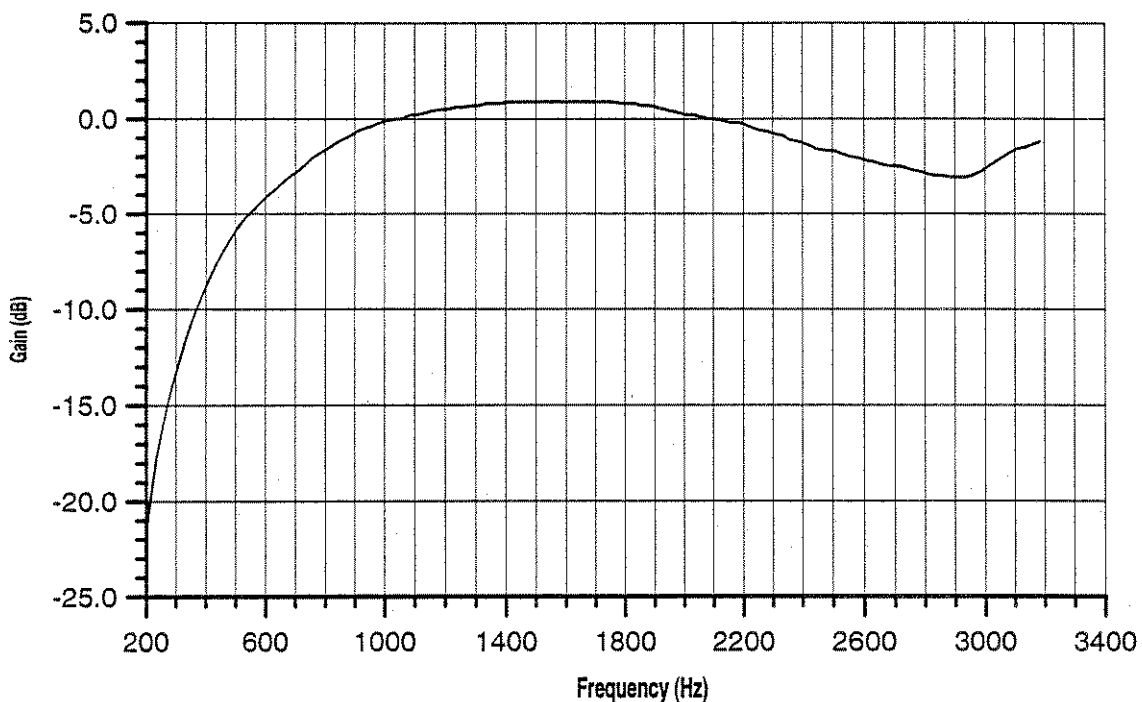

Figure 7-39. TAS "European Poor Data" Gain

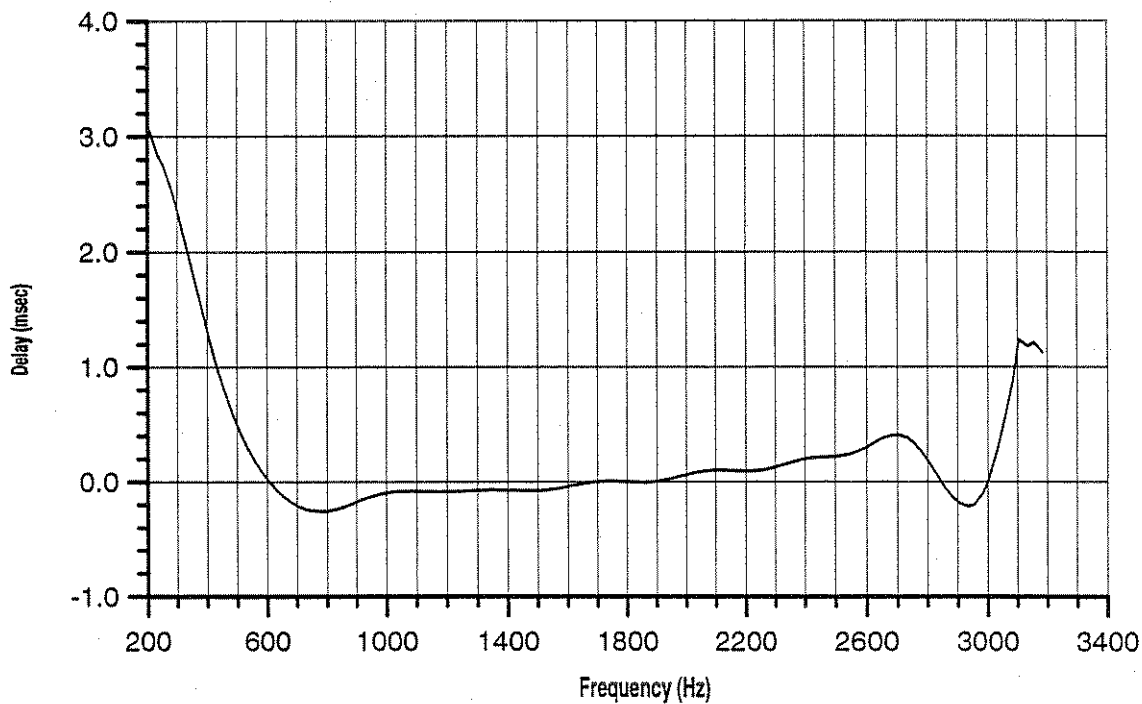

Figure 7-40. TAS "European Poor Data" Delay

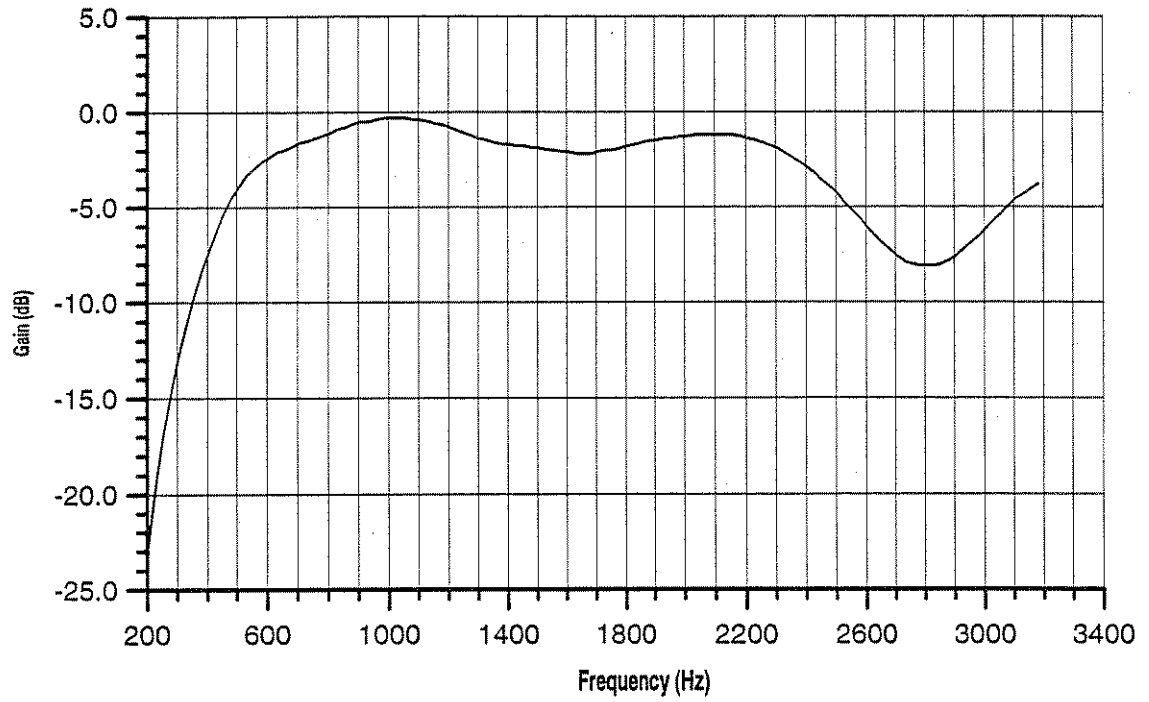

Figure 7-41. TAS "European Poor Voice" Gain

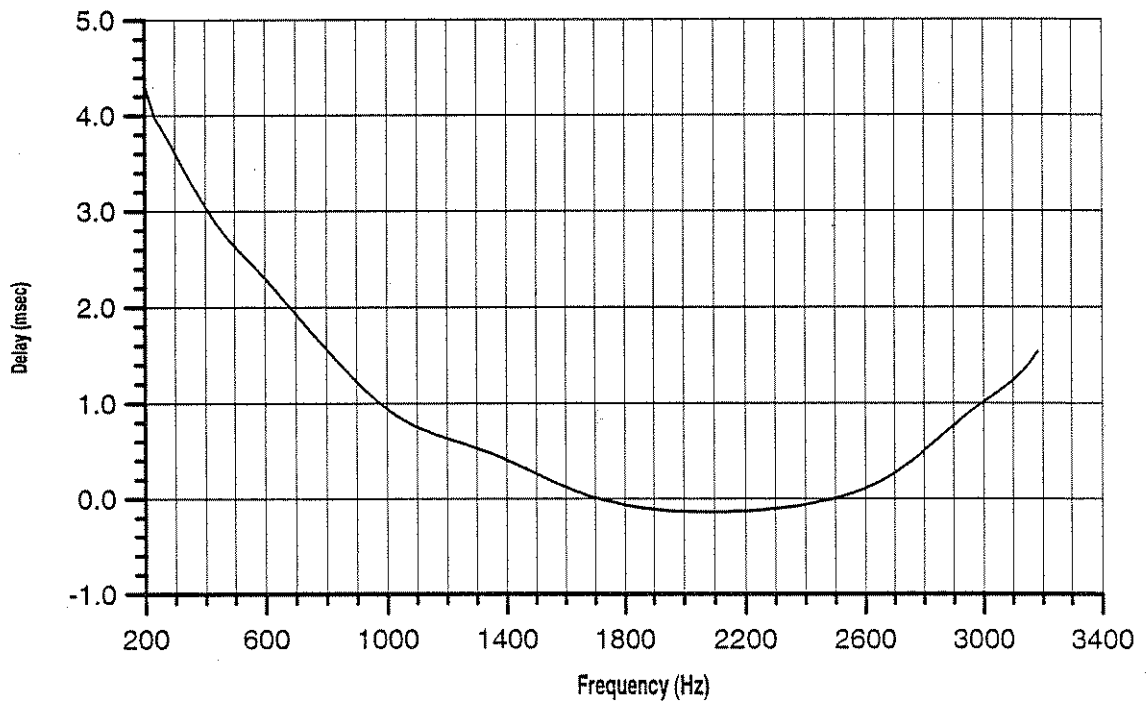

Figure 7-42. TAS "European Poor Voice" Delay

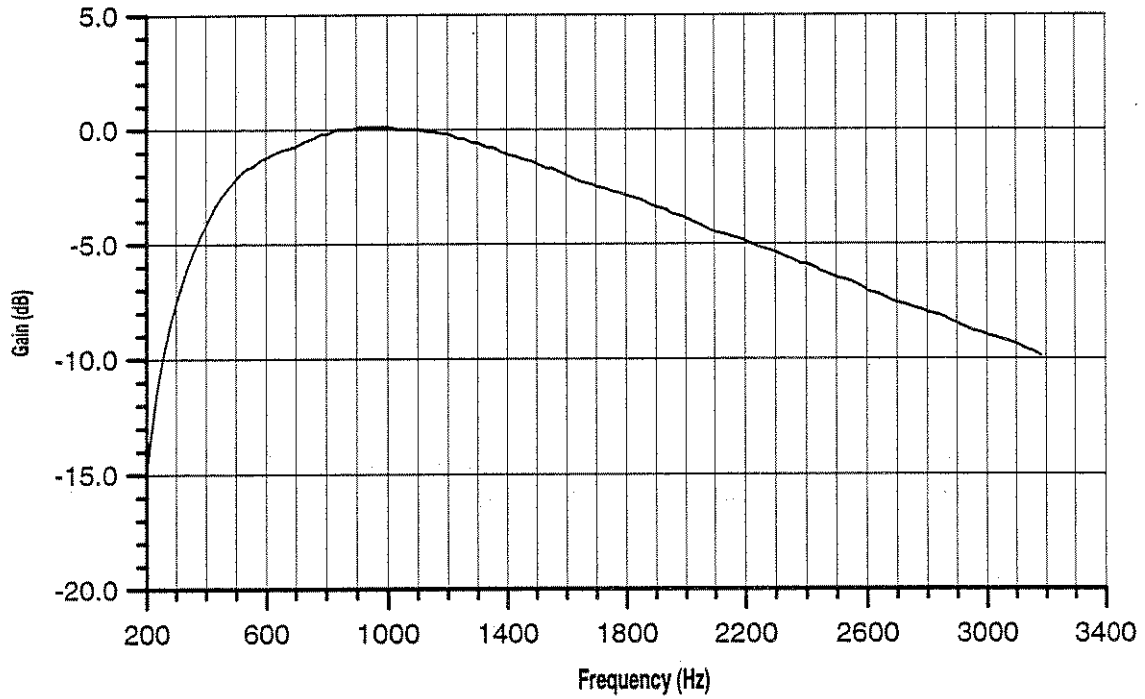

Figure 7-43. TAS "NSB" Gain

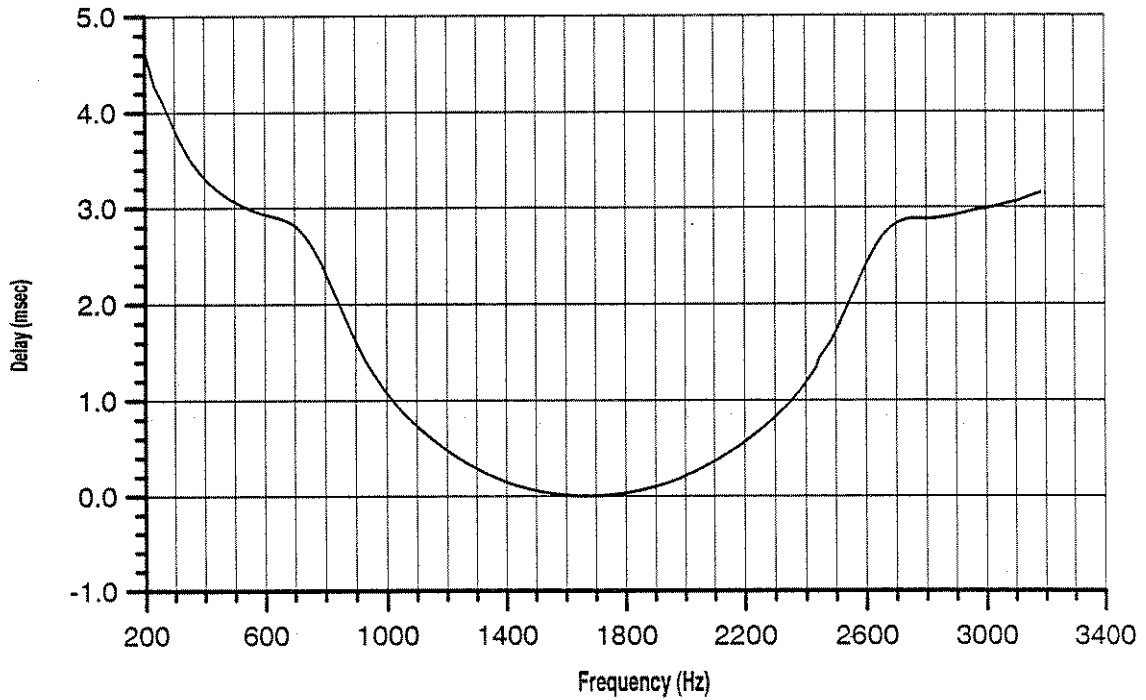

Figure 7-44. TAS "NSB" Delay

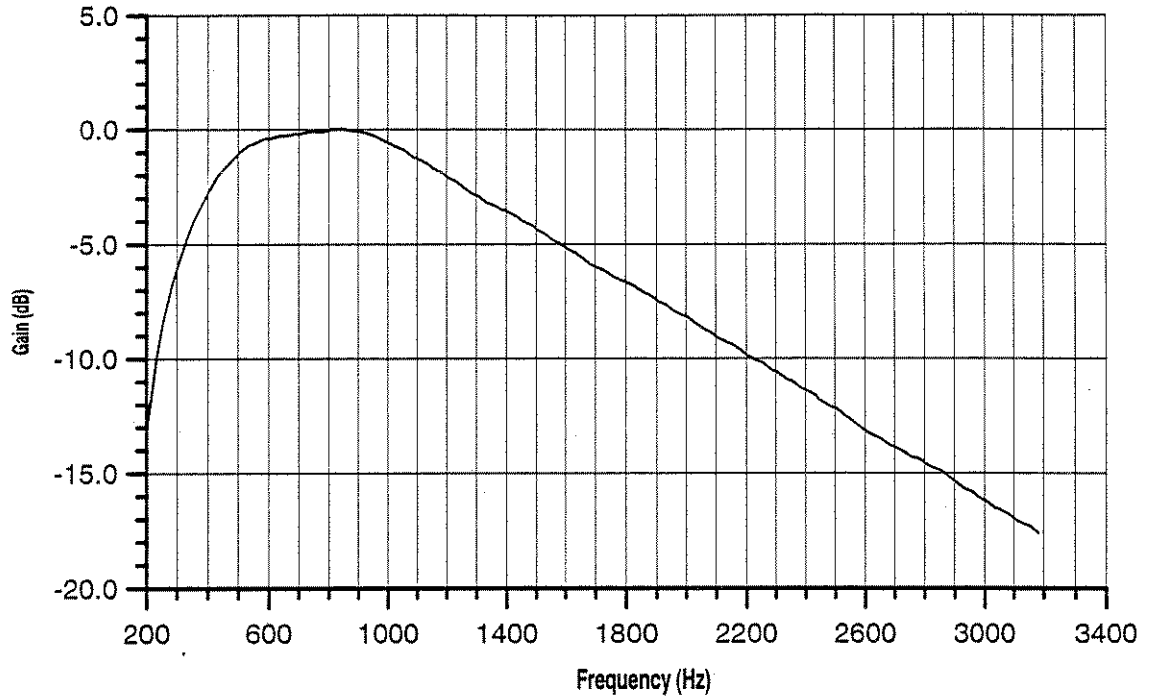

Figure 7-45. TAS "NTB" Gain

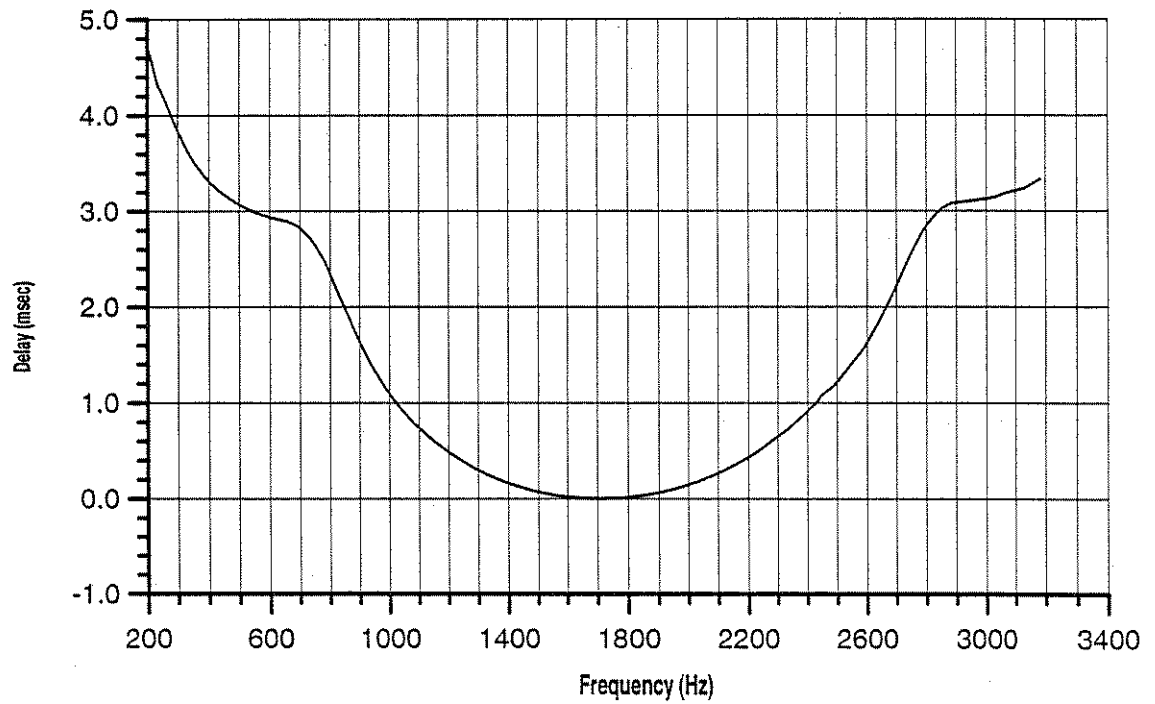

Figure 7-46. TAS "NTB" Delay

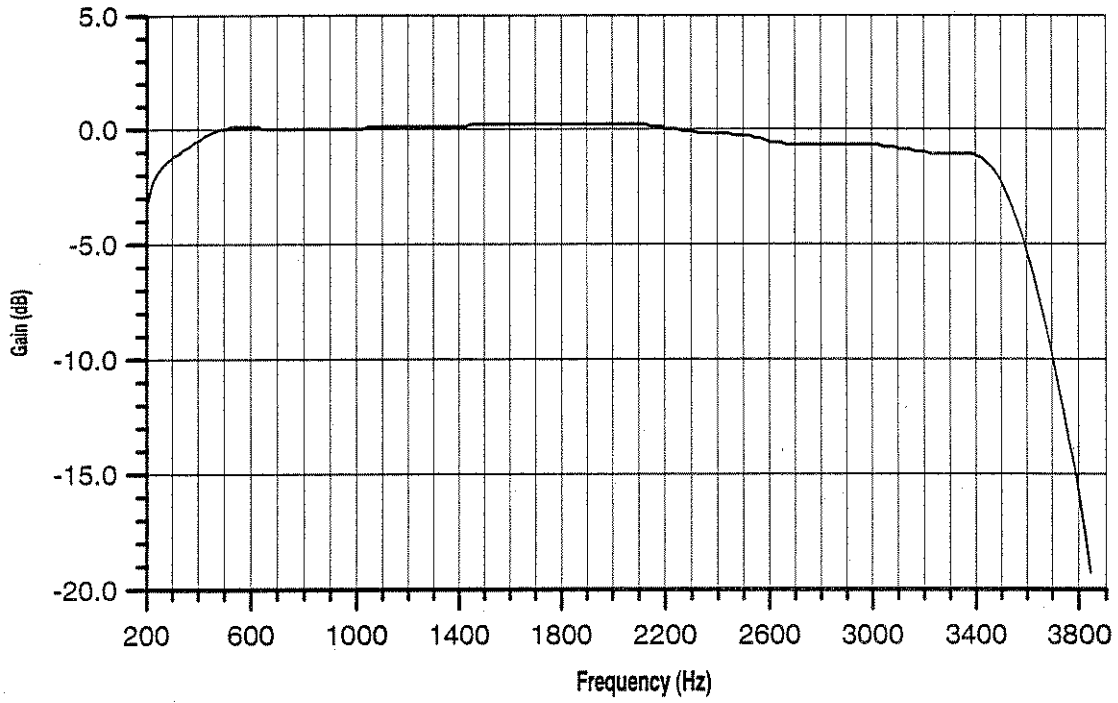

Figure 7-47. TAS JPN 1 Gain

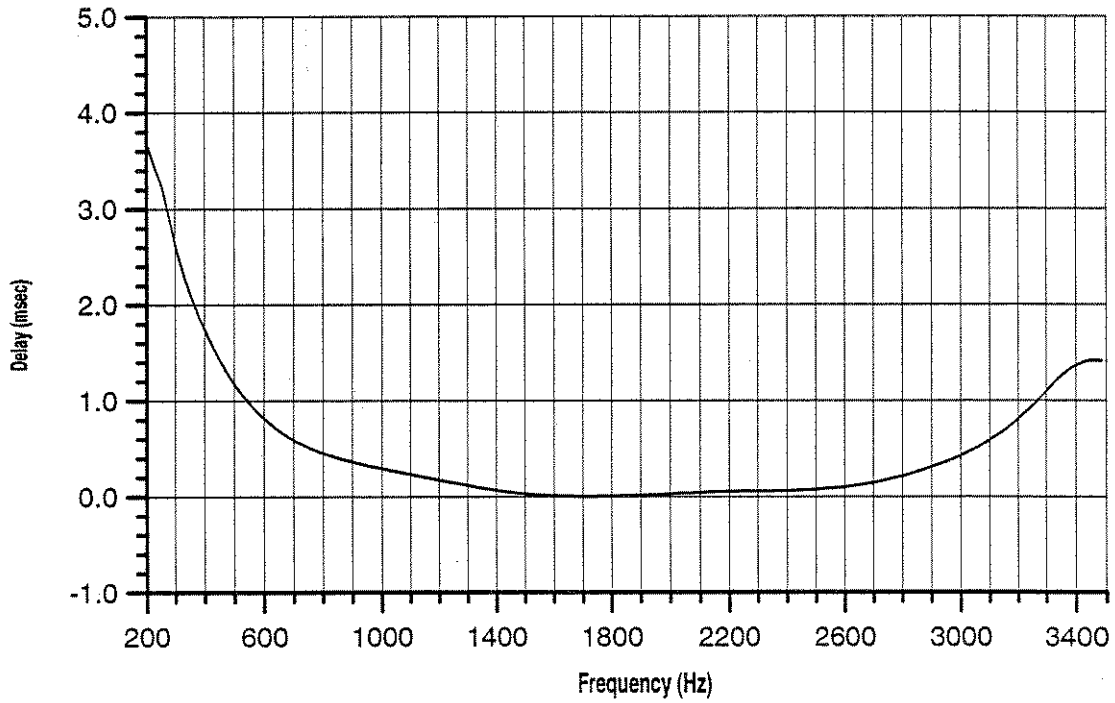

Figure 7-48. TAS JPN 1 Delay

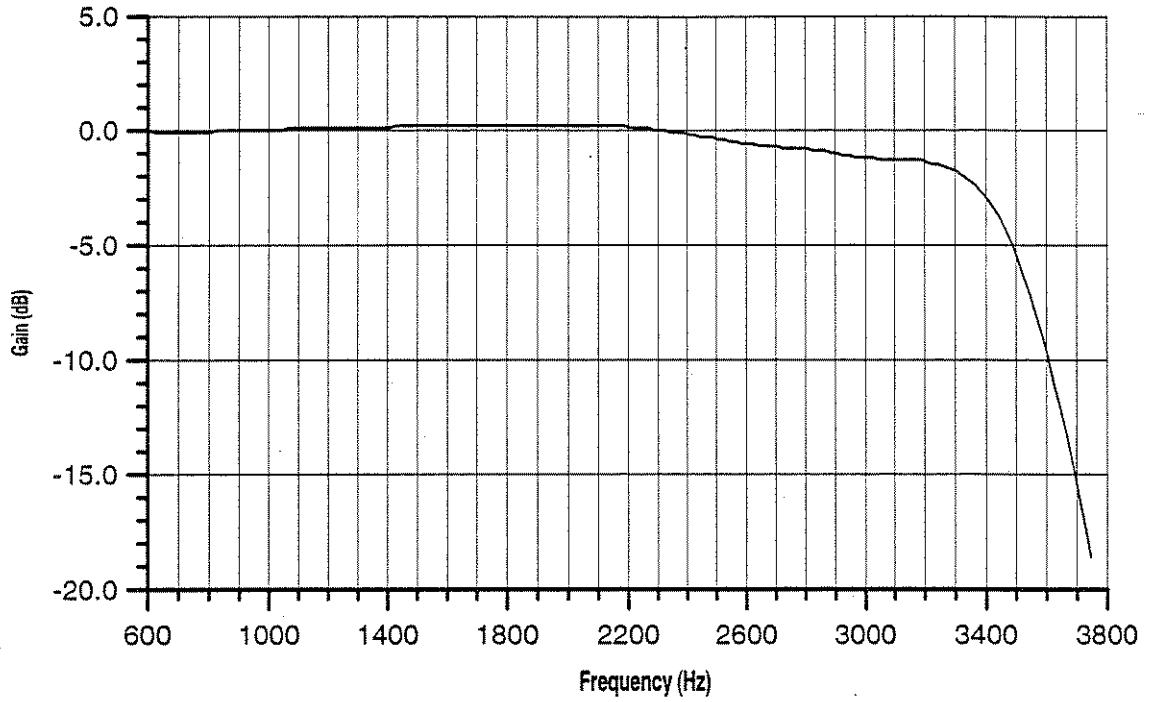

Figure 7-49. TAS JPN 2 Gain

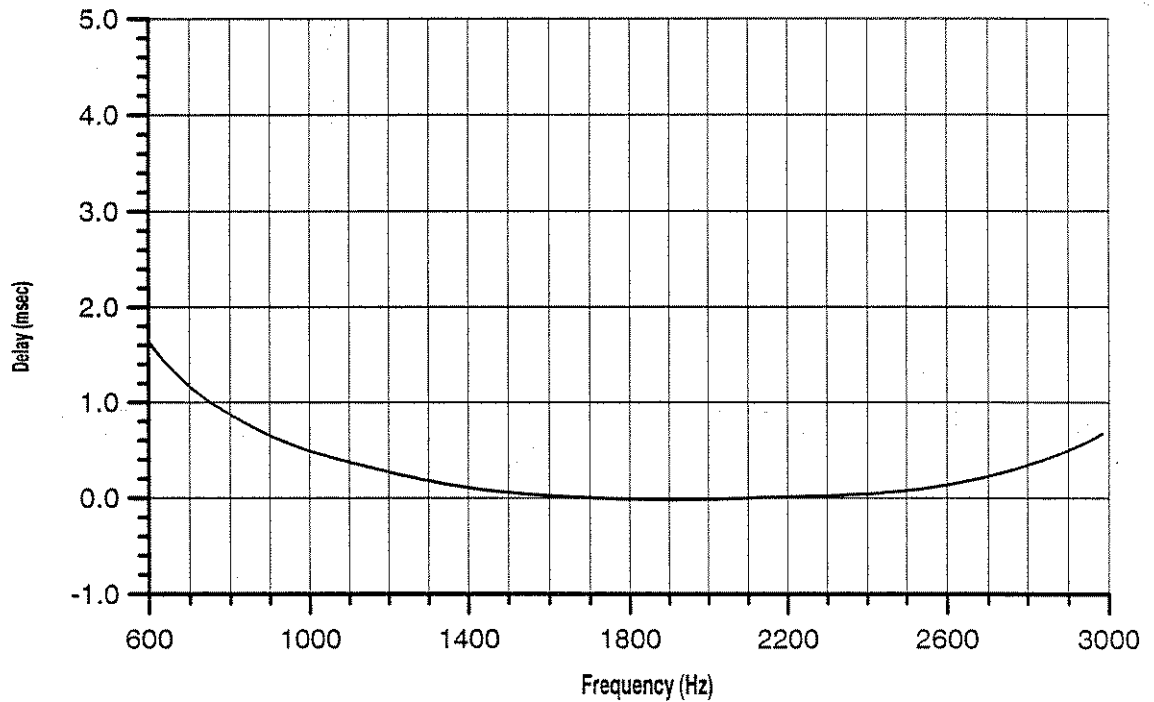

Figure 7-50. TAS JPN 2 Delay

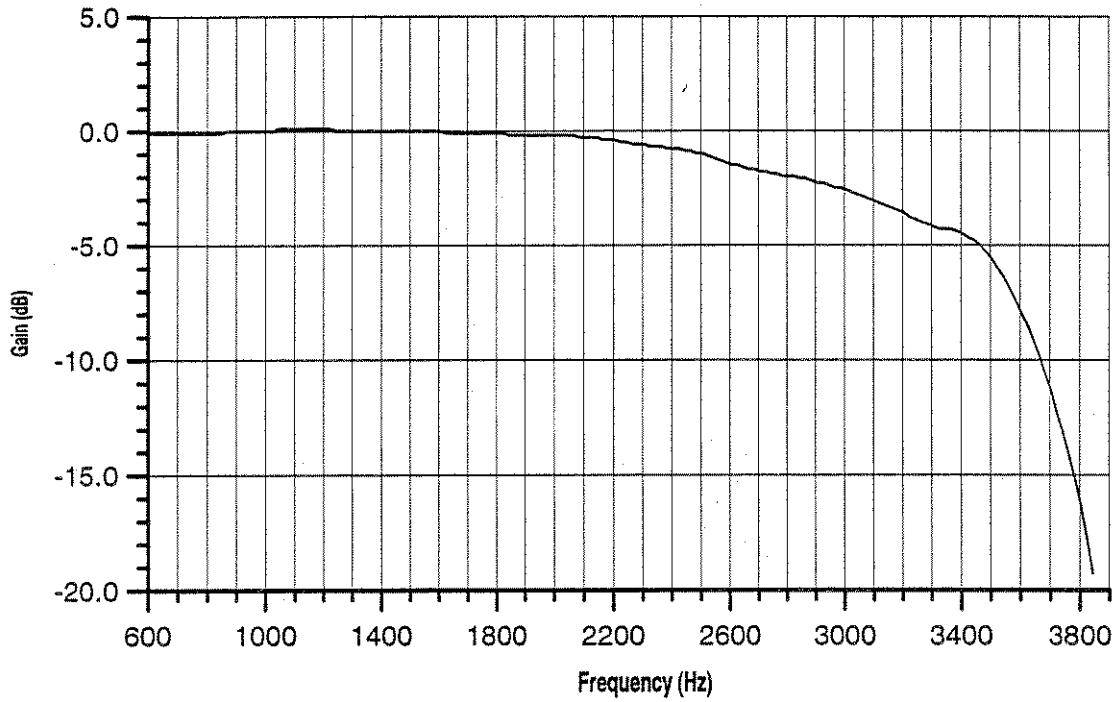

Figure 7-51. TAS JPN 3 Gain

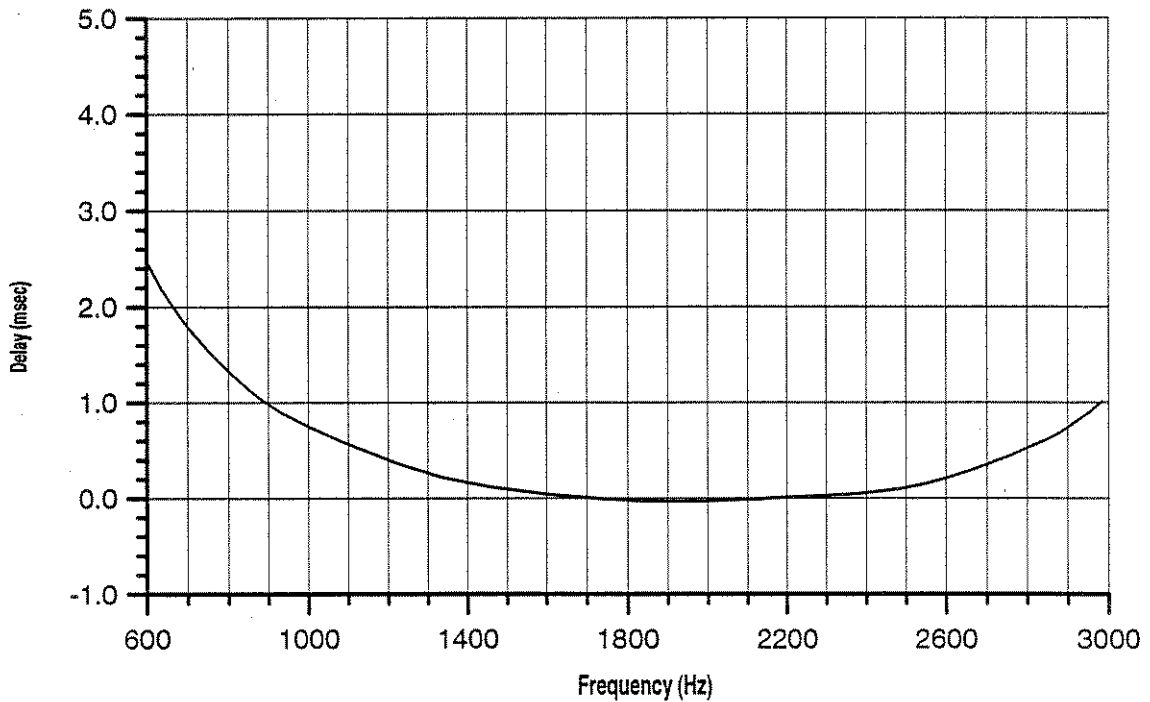

Figure 7-52. TAS JPN 3 Delay

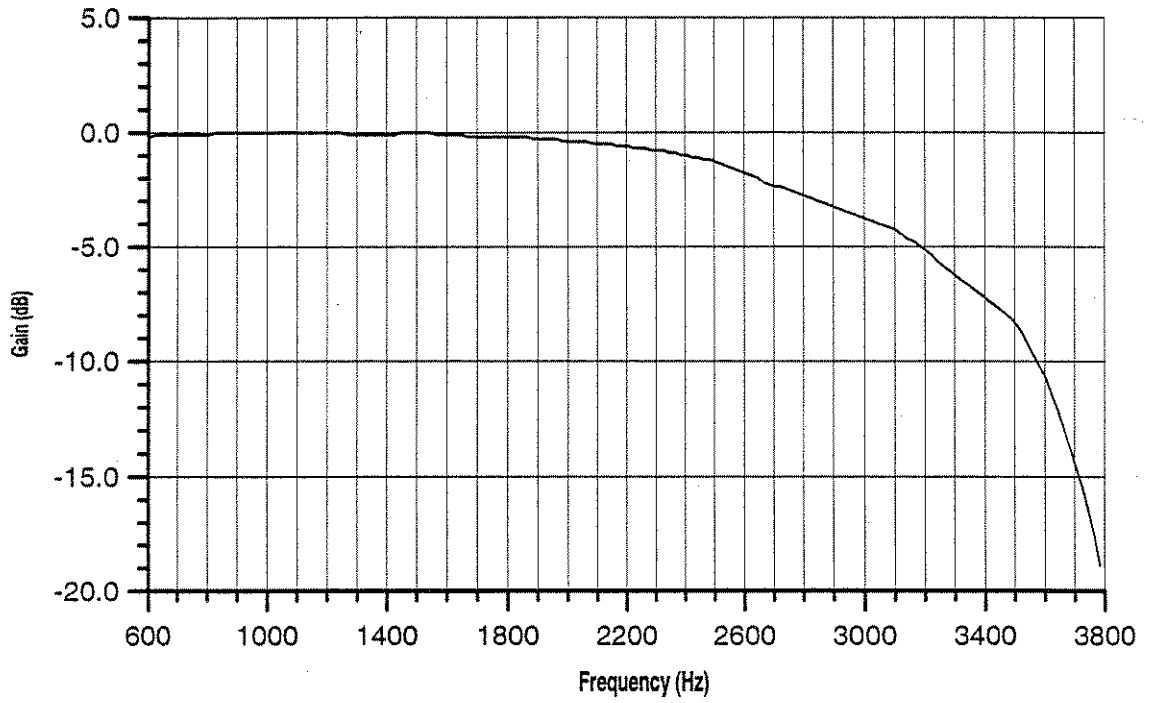

Figure 7-53. TAS JPN 4 Gain

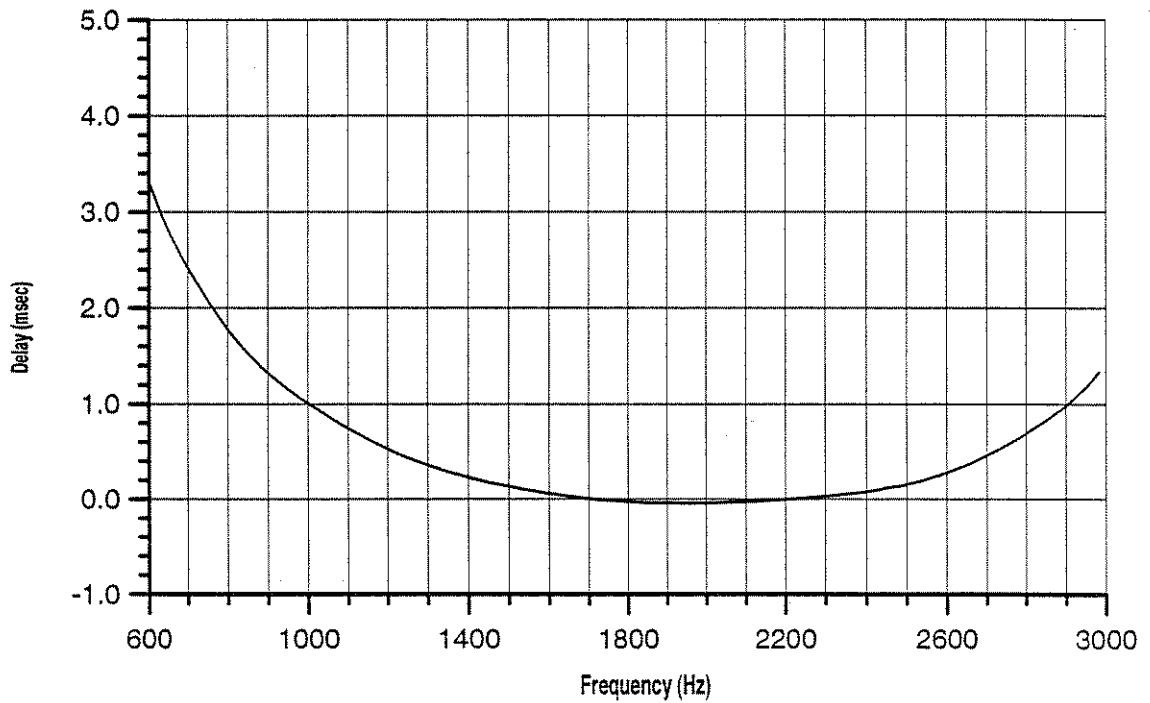

Figure 7-54. TAS JPN 4 Delay

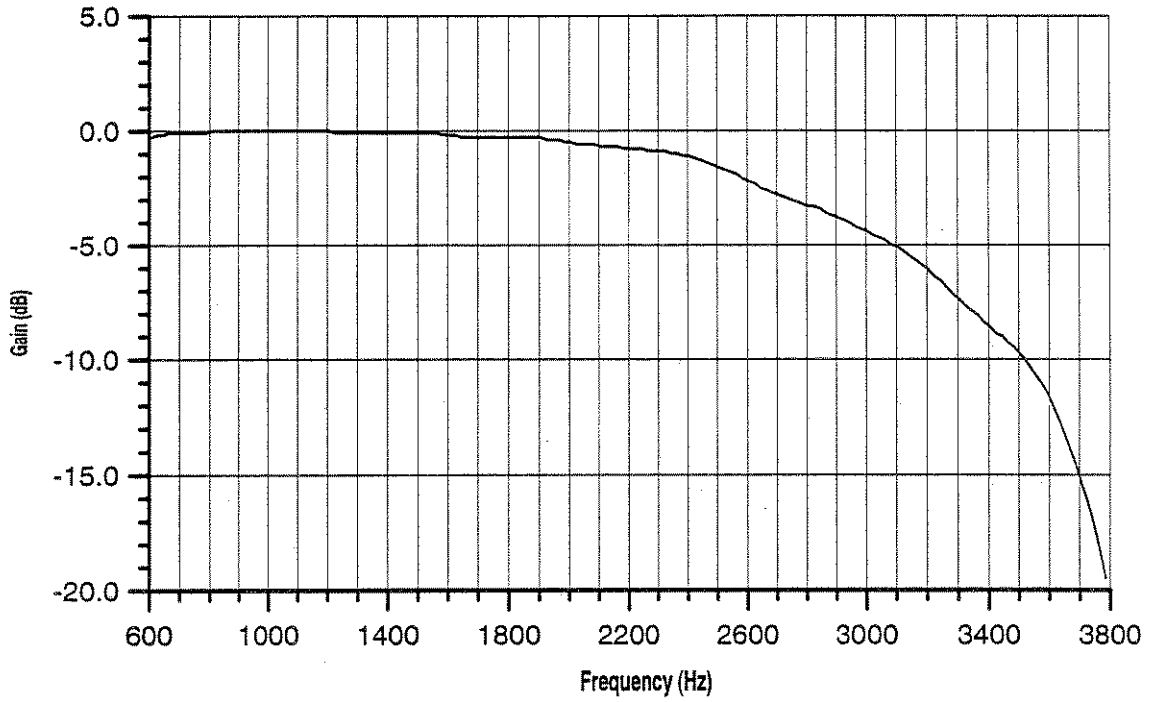

Figure 7-55. TAS JPN 5 Gain

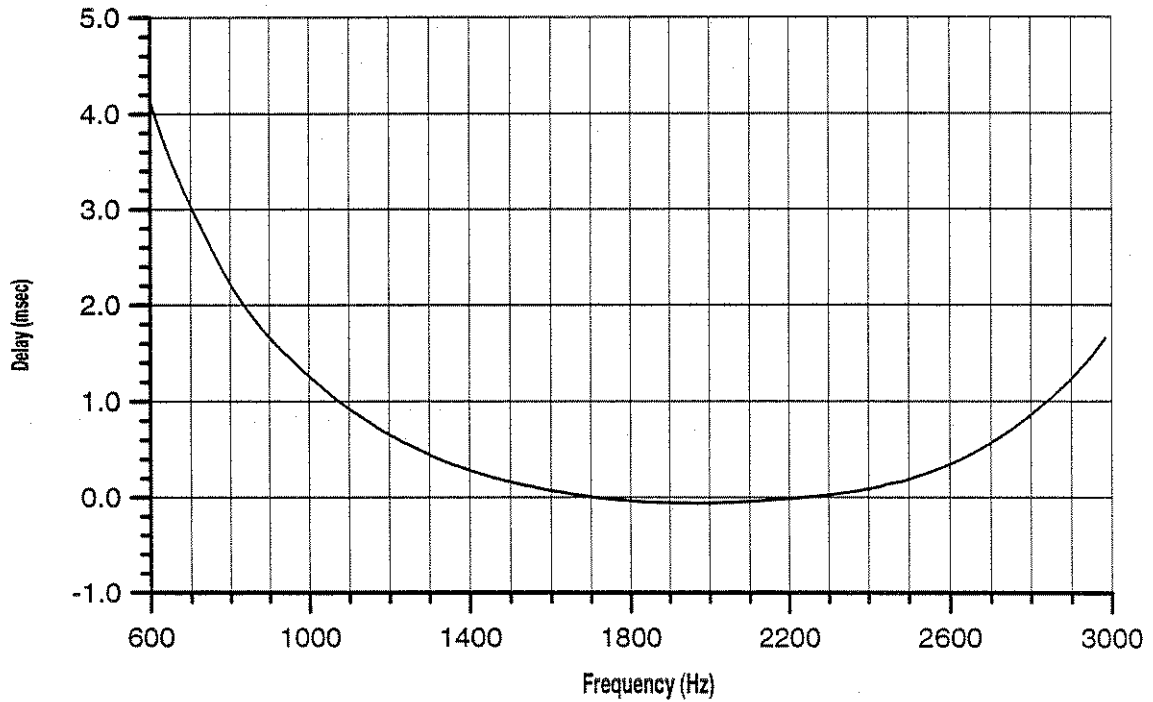

Figure 7-56. TAS JPN 5 Delay

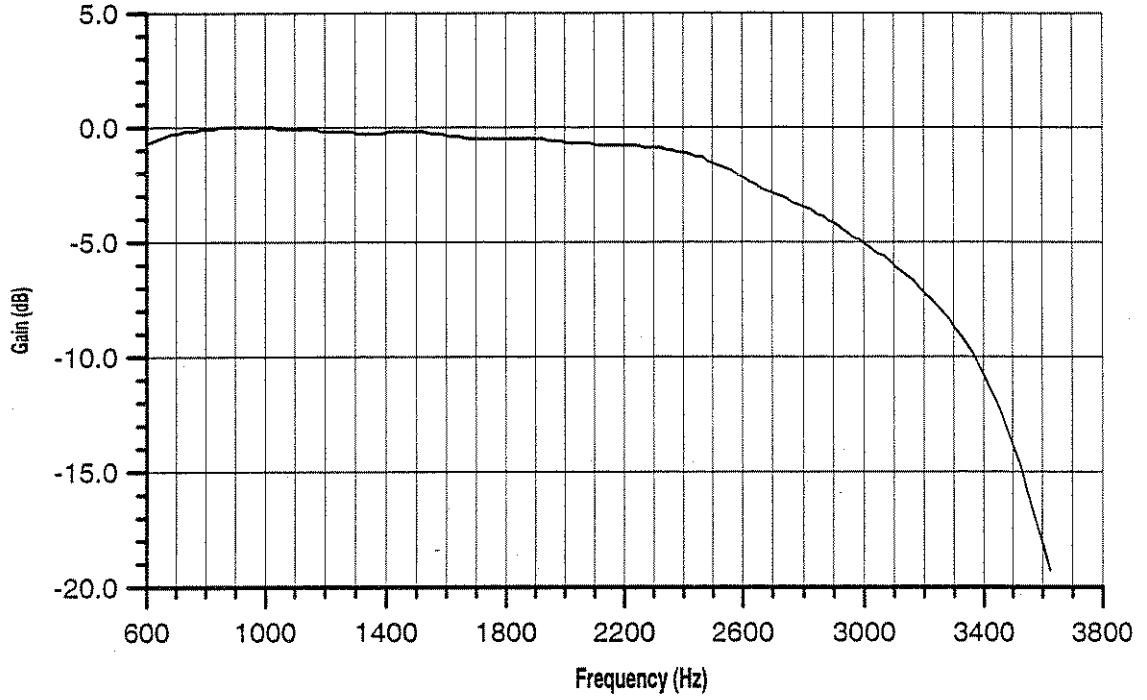

Figure 7-57. TAS JPN 6 Gain

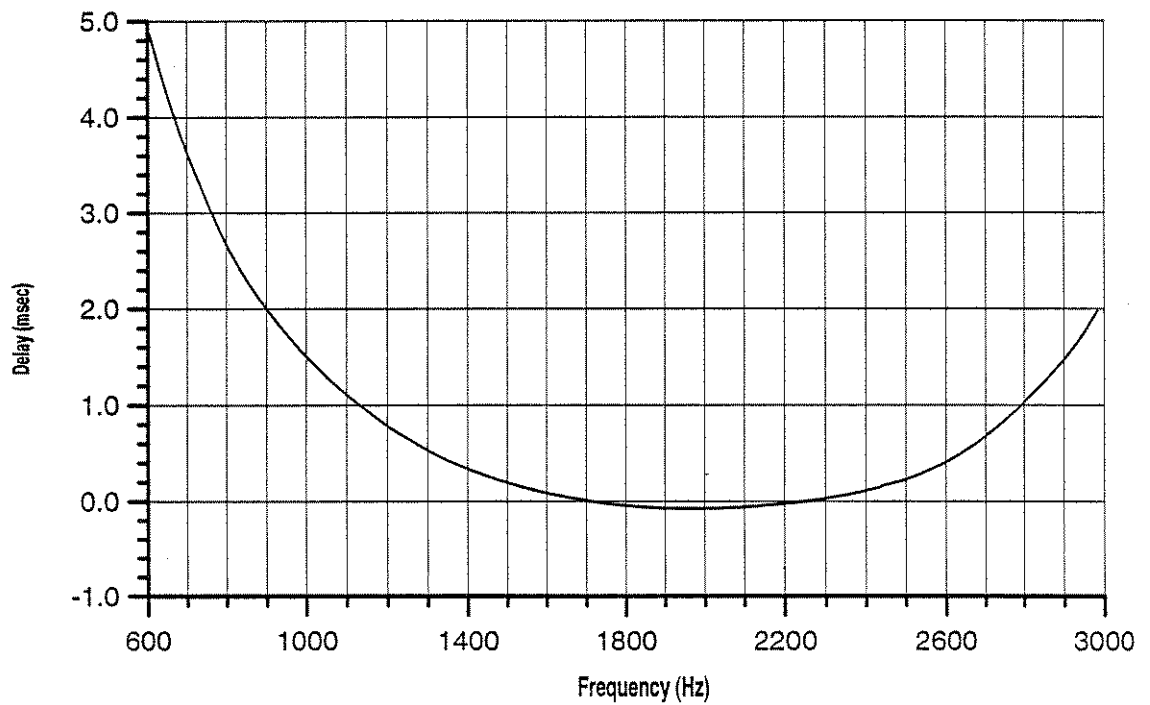

Figure 7-58. TAS JPN 6 Delay

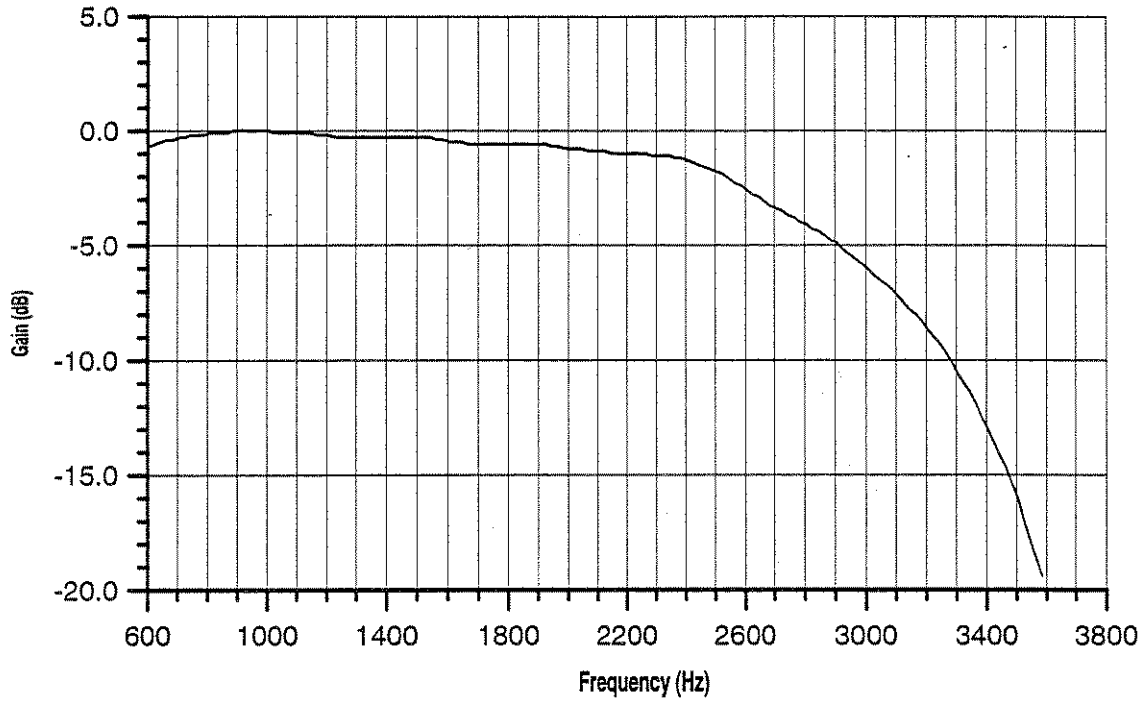

Figure 7-59. TAS JPN 7 Gain

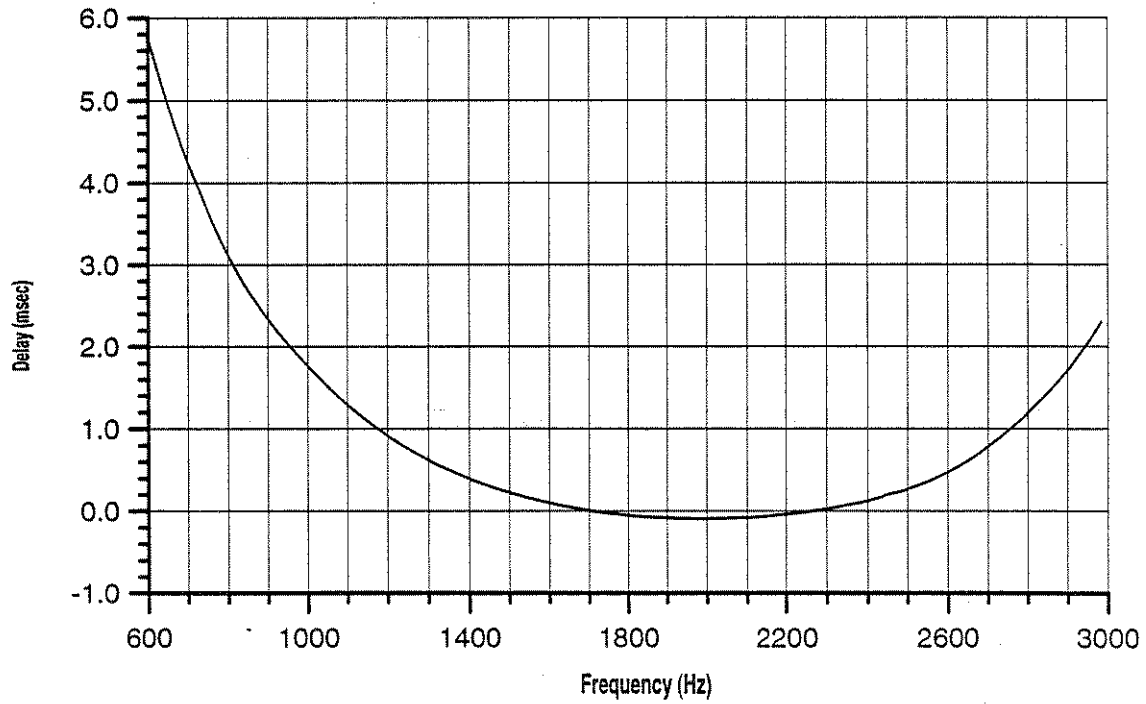

Figure 7-60. TAS JPN 7 Delay

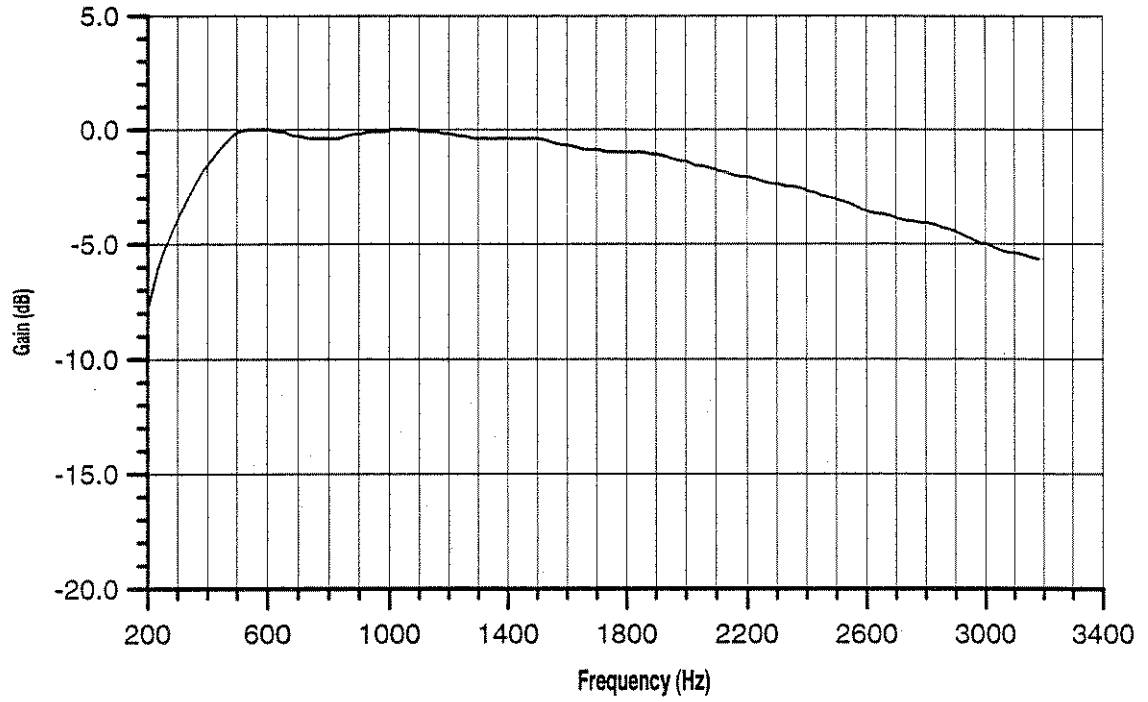

Figure 7-61. TAS CCITT R28 Gain

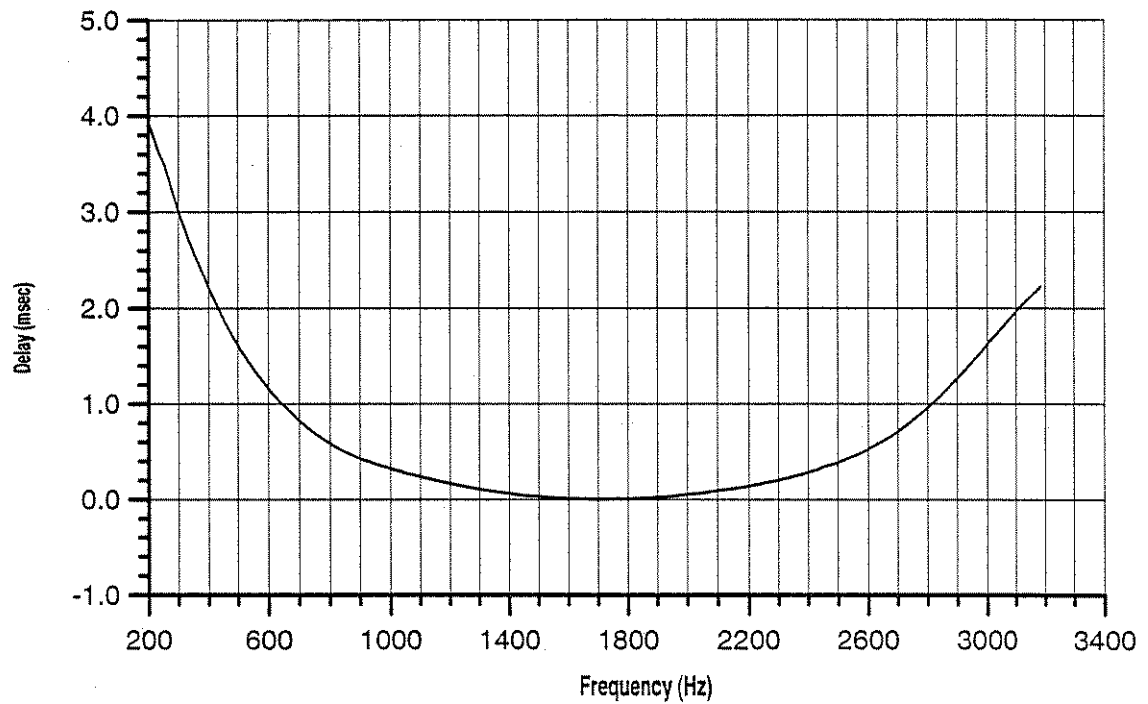

Figure 7-62. TAS CCITT R28 Delay

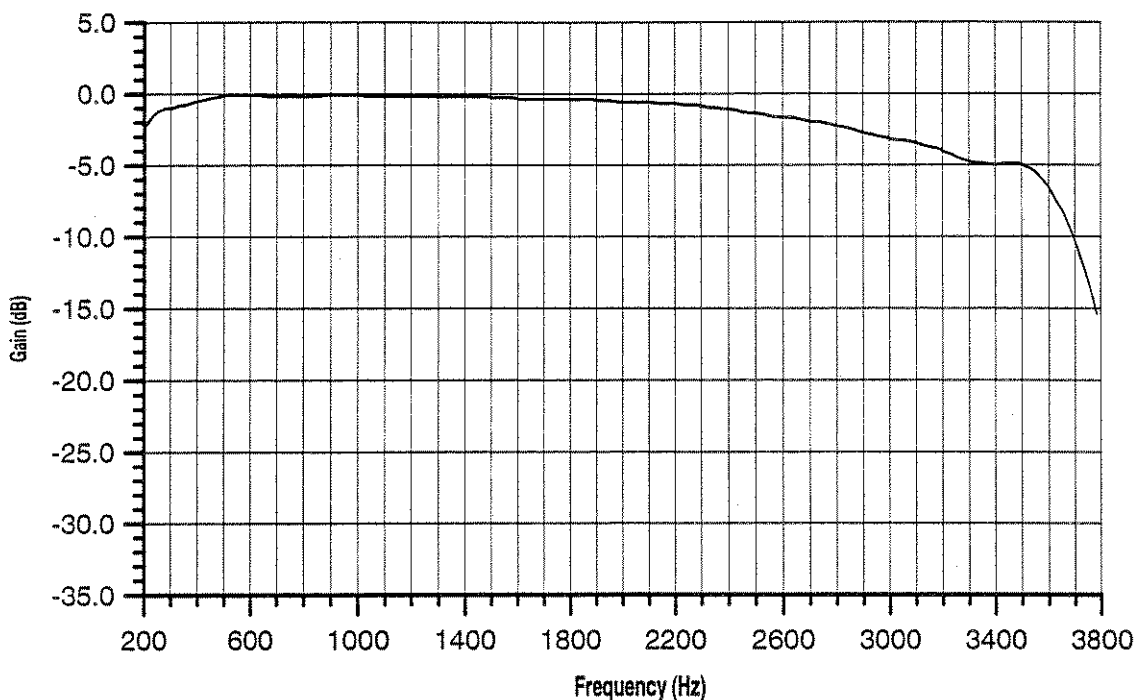

Figure 7-63. TAS EIA/CCITT Cable-1 Gain

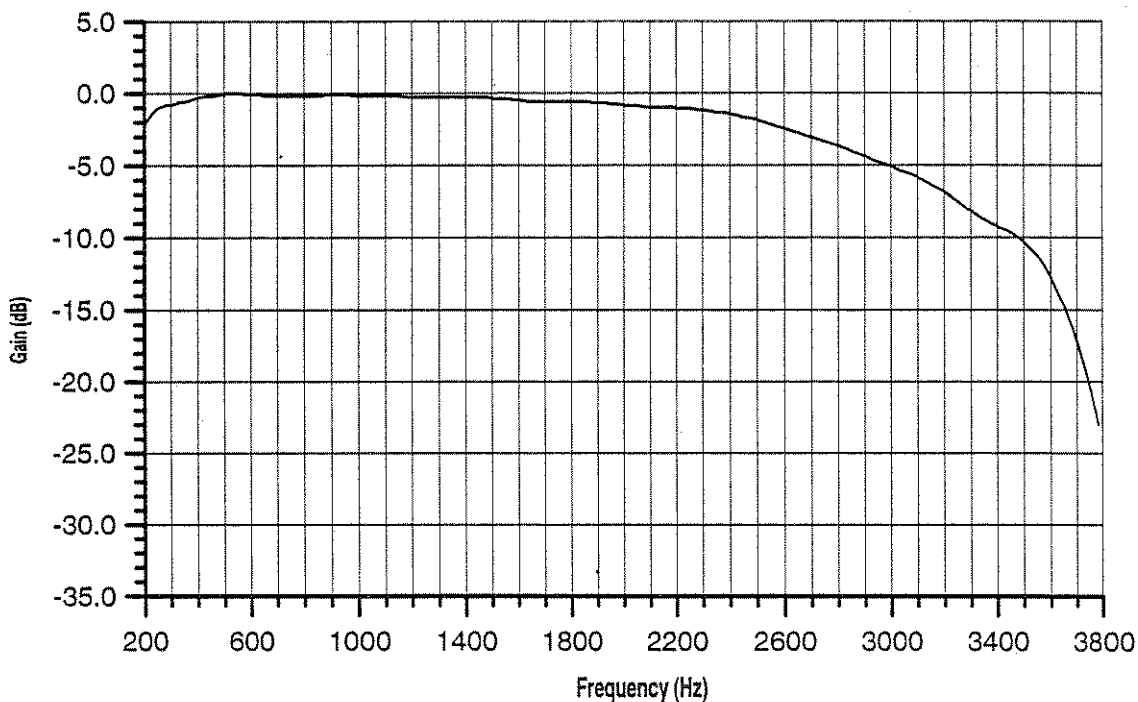

Figure 7-64. TAS EIA/CCITT Cable-2 Gain

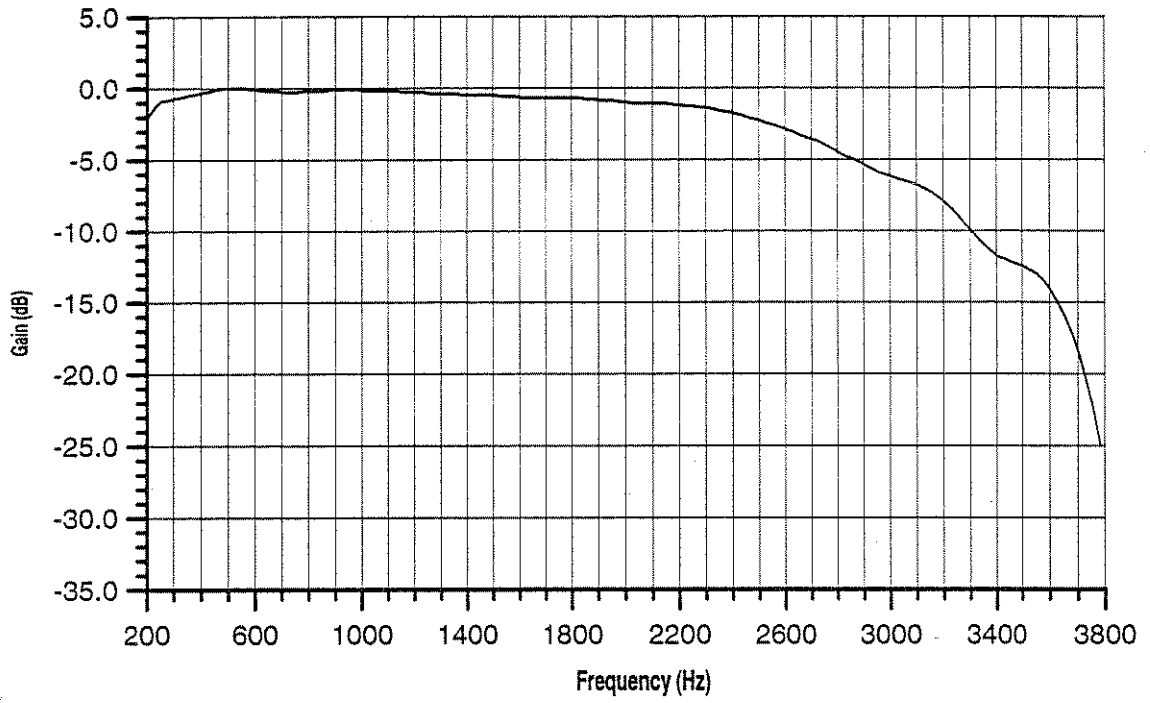

Figure 7-65. TAS EIA/CCITT Cable-3 Gain

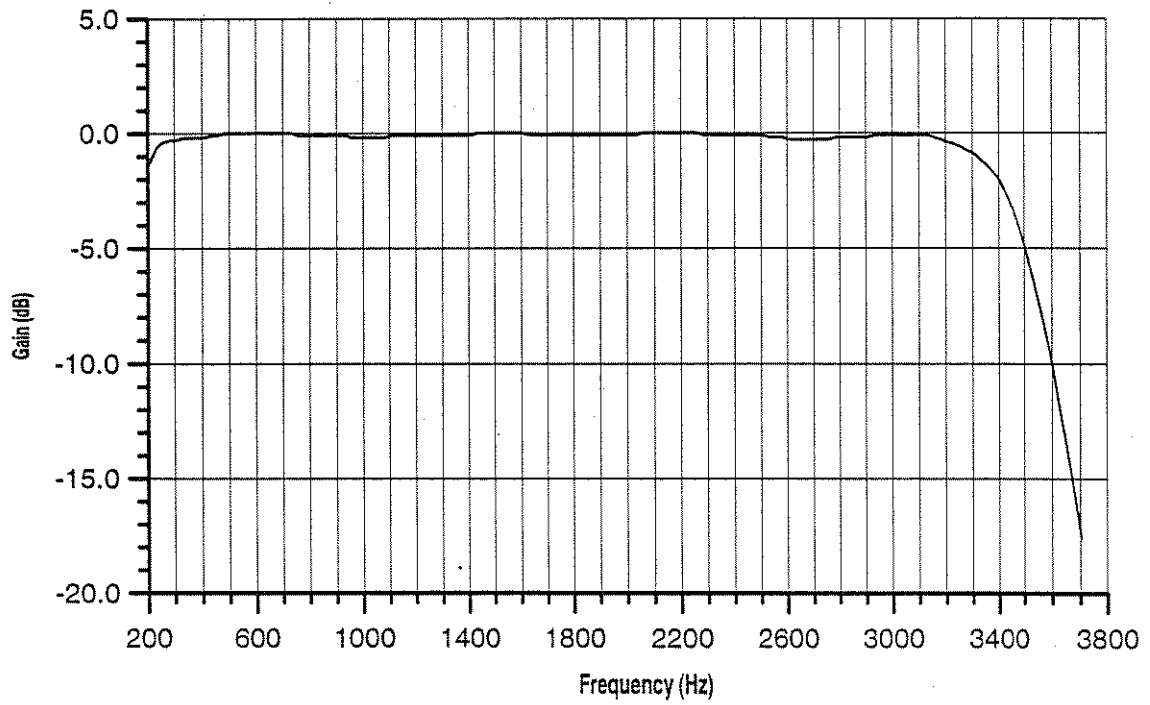

Figure 7-66. PCM Gain [151, 152, 181]

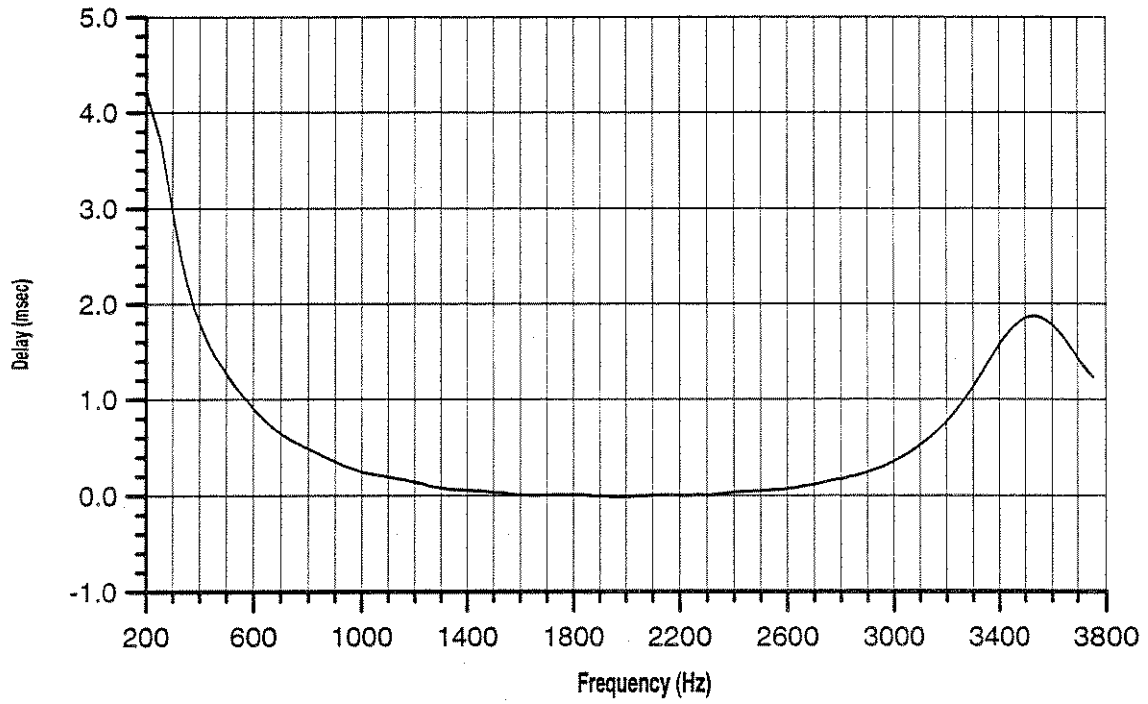

Figure 7-67. PCM Delay [151, 152, 181]

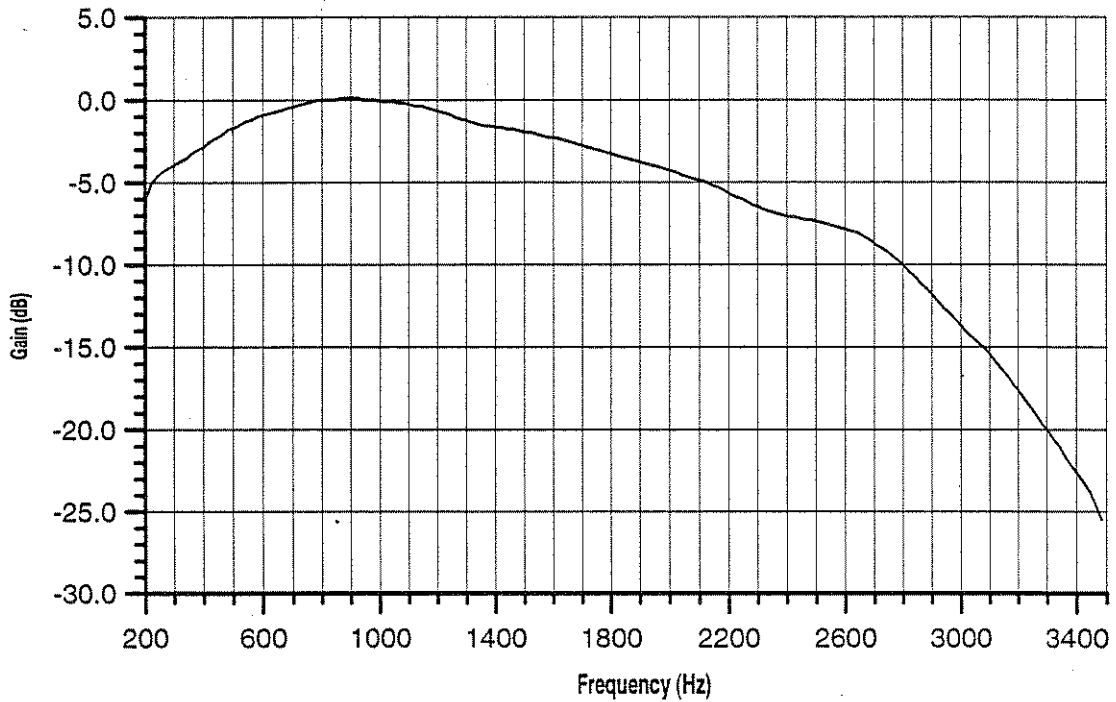

Figure 7-68. RITT Gain

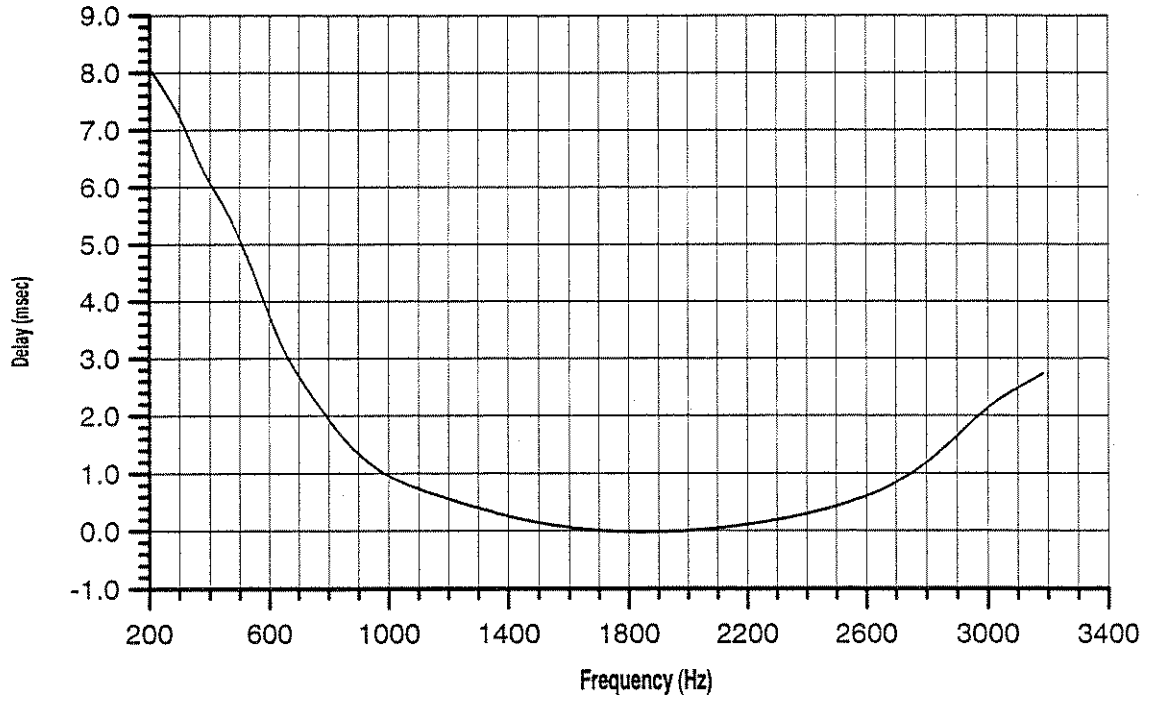

Figure 7-69. RITT1 Delay

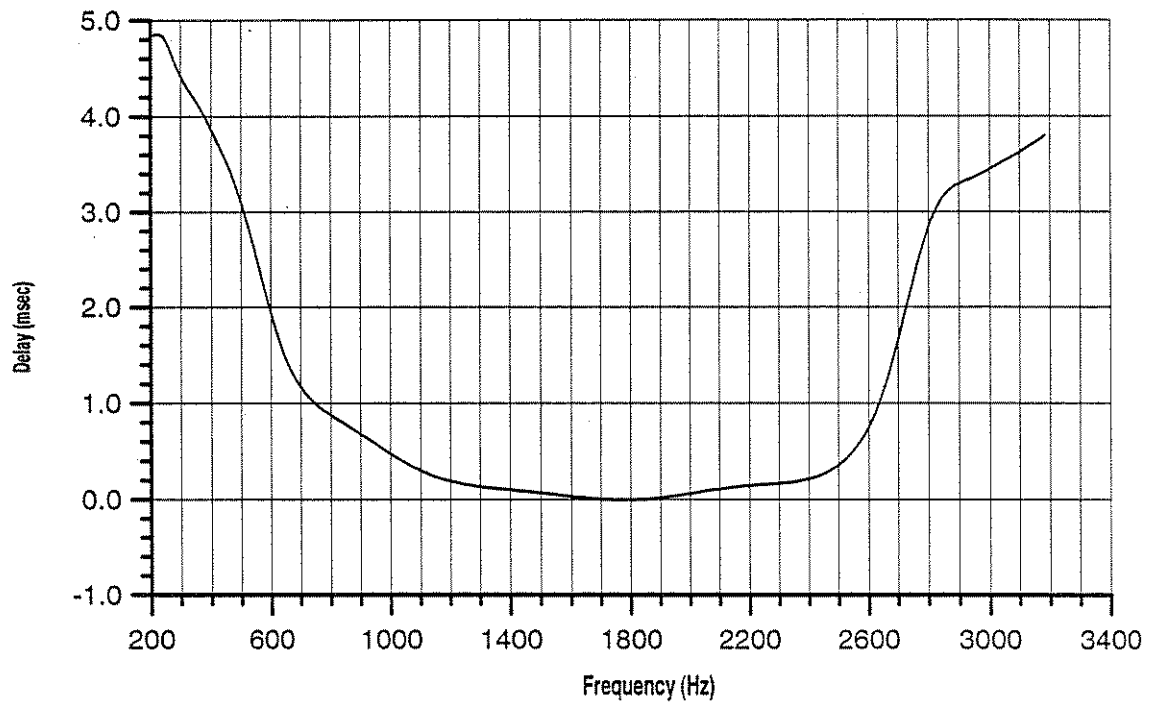

Figure 7-70. RITT2 Delay

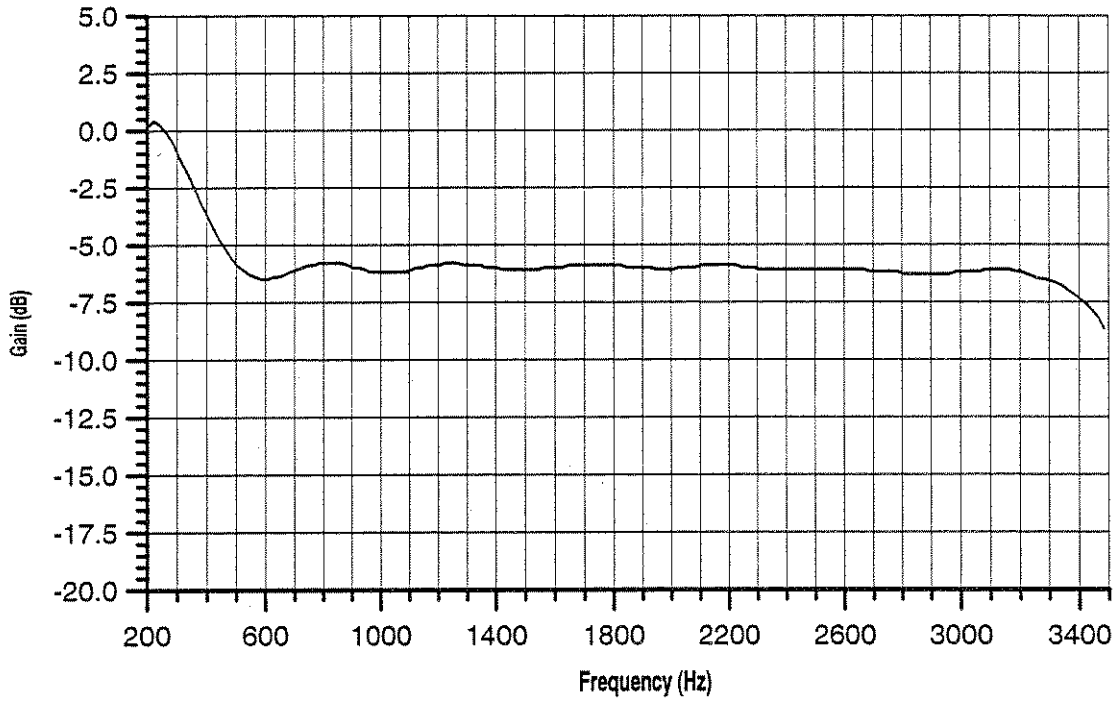

Figure 7-71. TR_50150 Gain

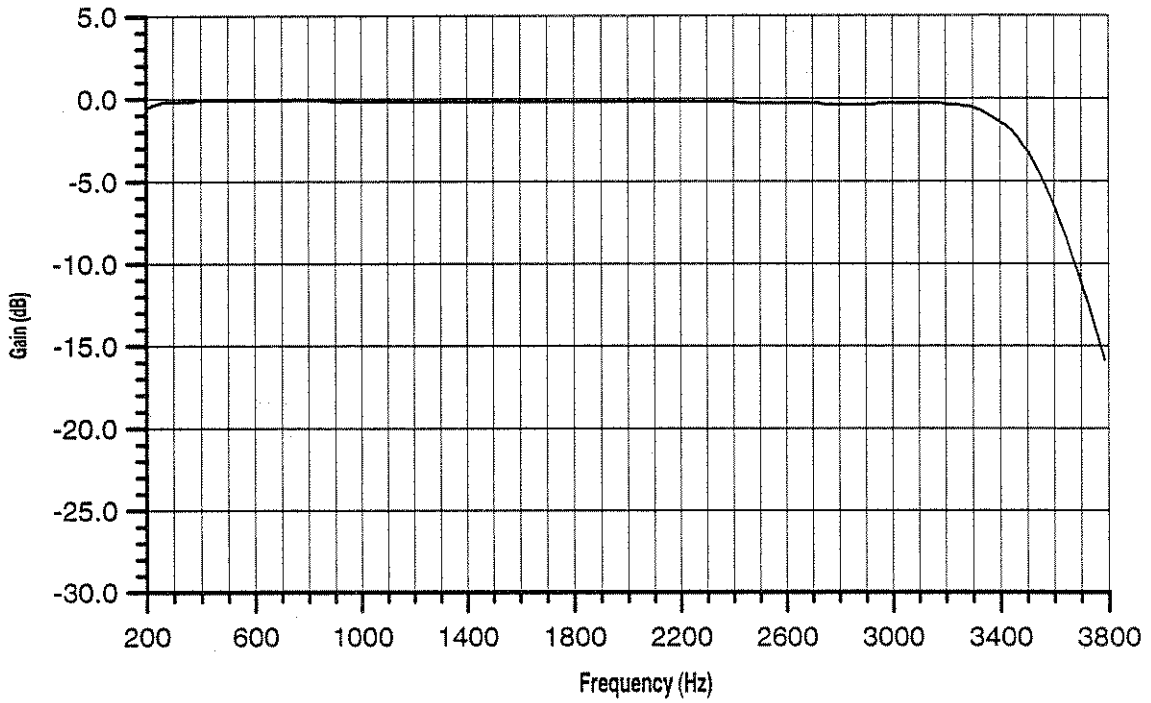

Figure 7-72. PCM Gain - 1 Link [182]

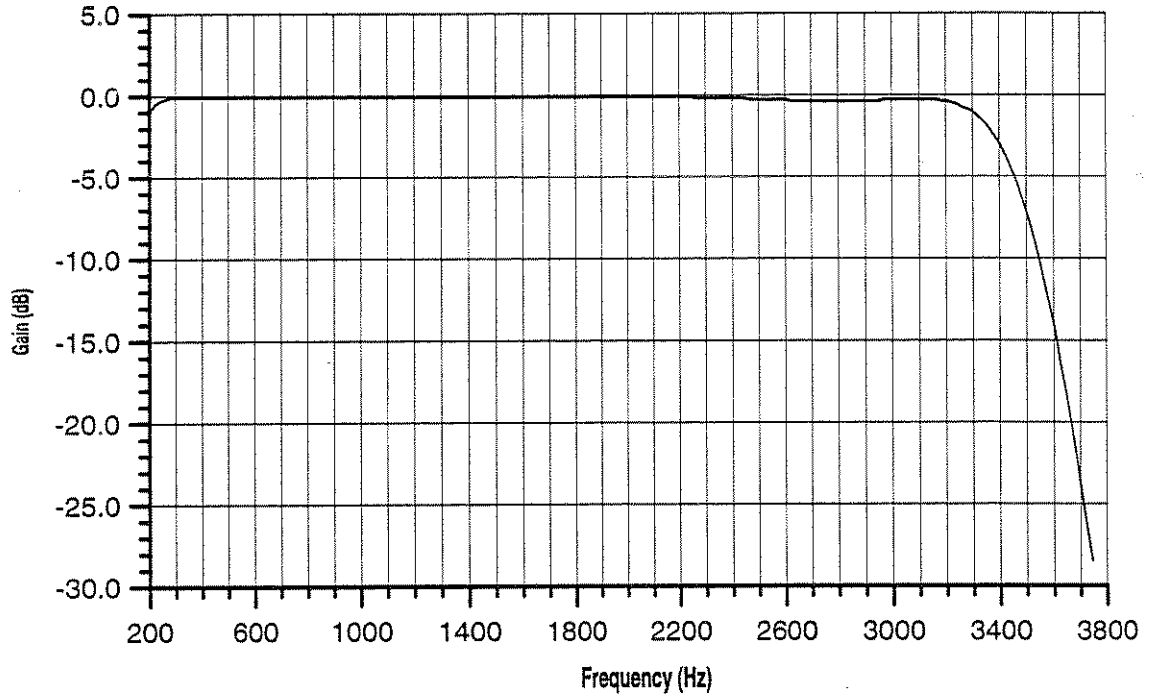

Figure 7-73. PCM Gain - 2 Links [182]

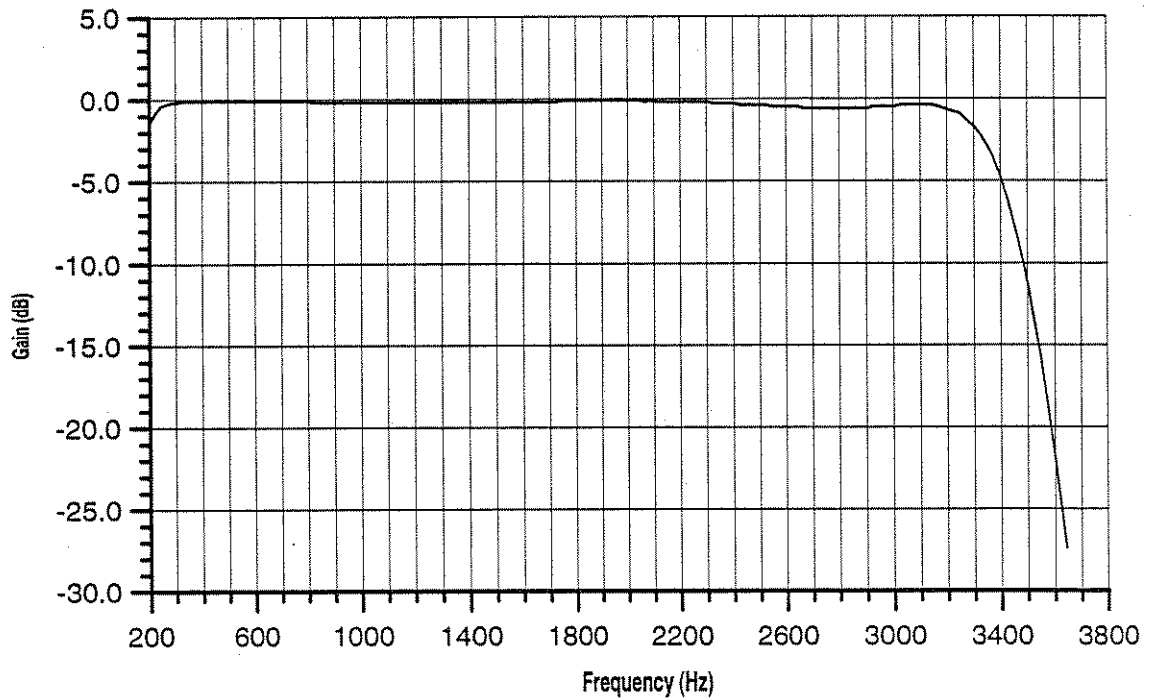

Figure 7-74. PCM Gain - 3 Links [182]

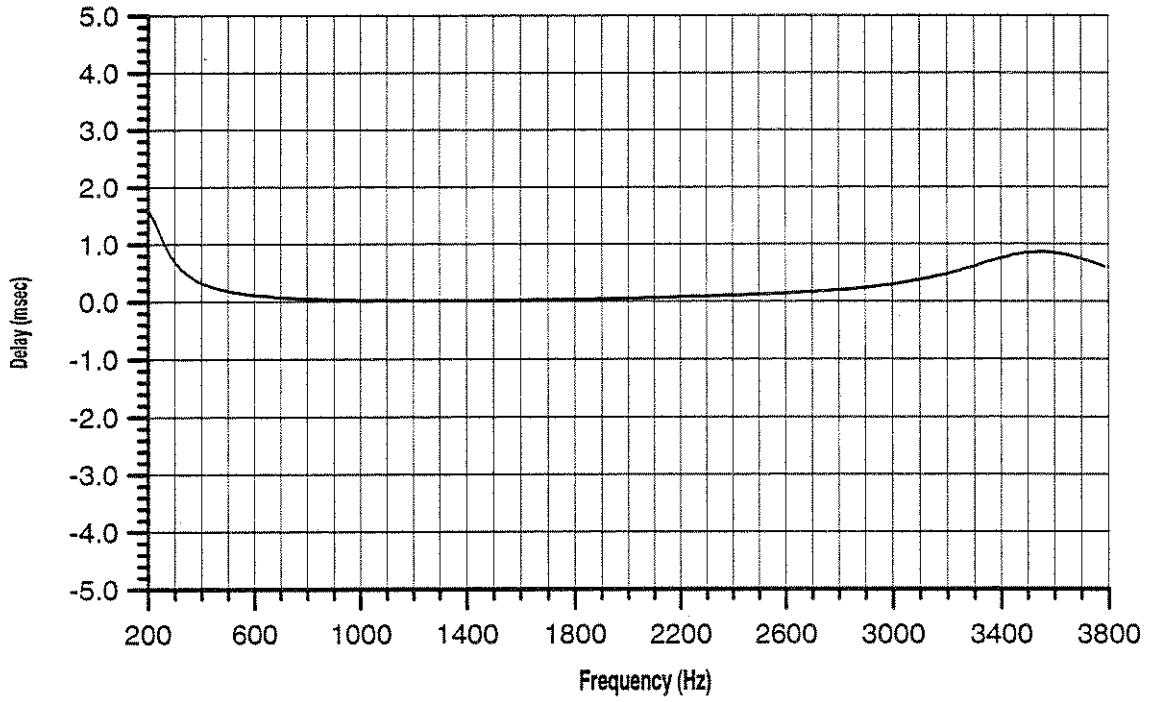

Figure 7-75. PCM Delay - 1 Link [182]

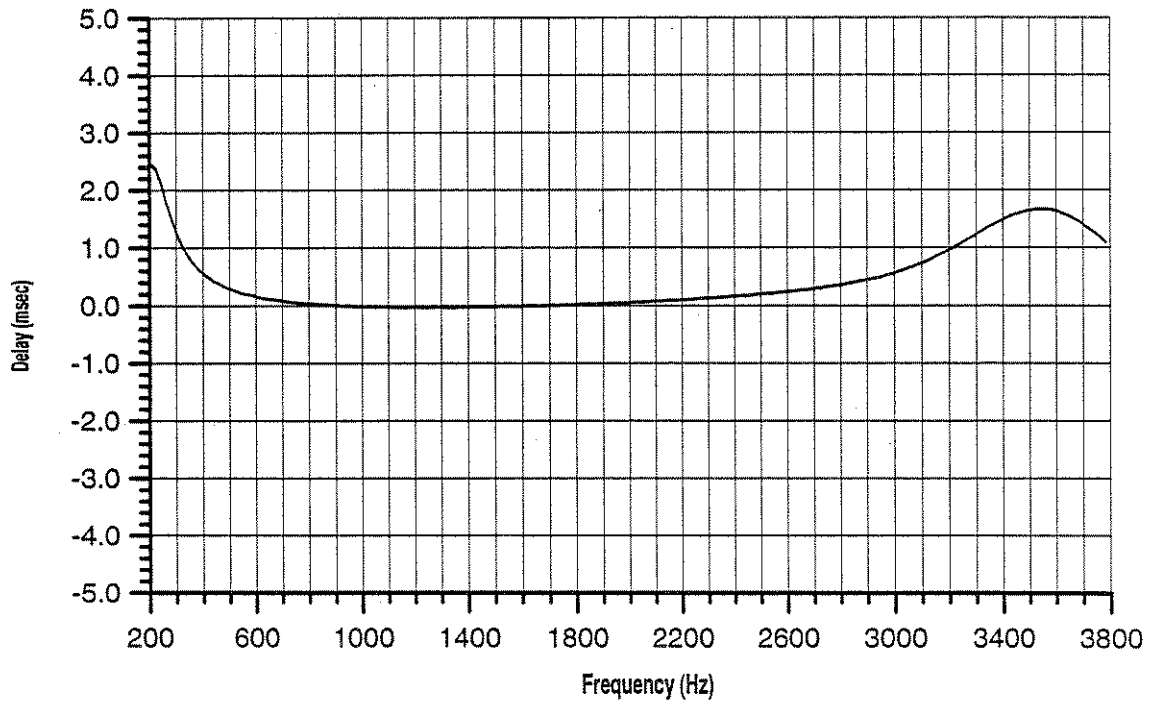

Figure 7-76. PCM Delay - 2 Links [182]

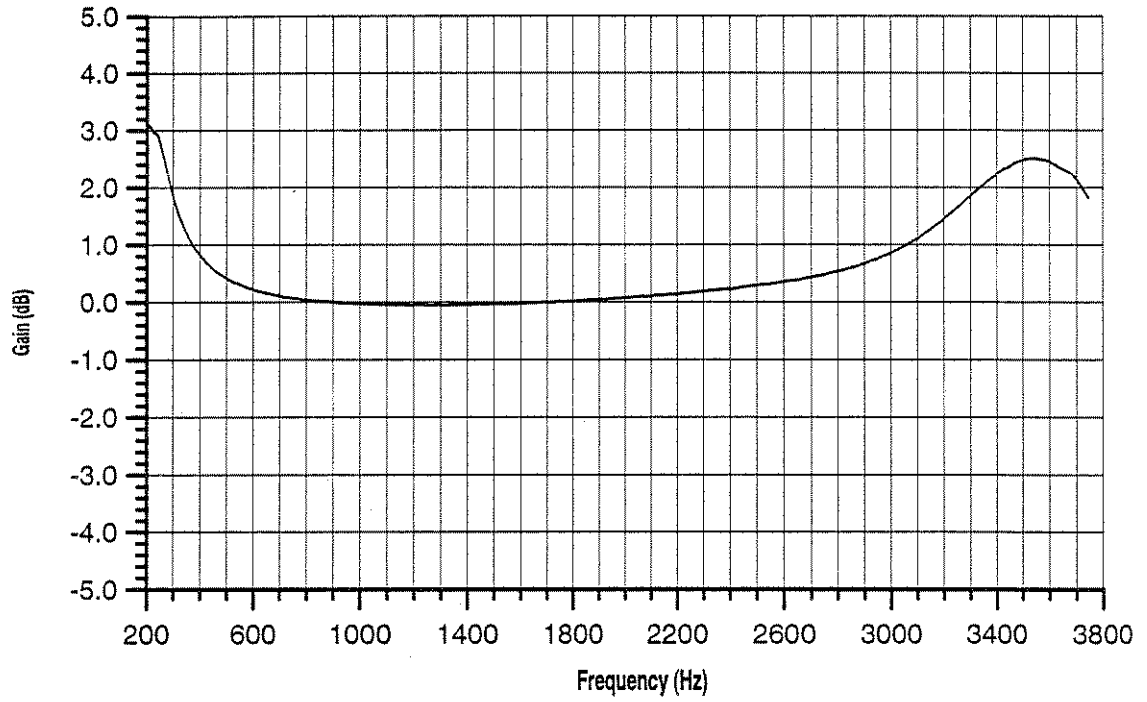

Figure 7-77. PCM Delay - 3 Links [182]

This page intentionally left blank.

APPENDIX 1: FEATURE RELEASE HISTORY

The following sections outline all changes made to the TAS 100 Series firmware since version 2.0. Higher (more recent) versions incorporate all previous features of lower (older) versions.

A1.1. Version 4.30

The following are the changes incorporated into the 100 Series Version 4.30 firmware.

- 4-wire private-line / 2-wire switched operating mode was added to facilitate the TAS GT-Cellular Lite test configuration.

A1.2. Version 4.20

The following are the changes incorporated into the 100 Series Version 4.20 firmware.

- Up to 3 PCM links can be selected on Model 182. These PCM links can be positioned as either the first or last impairment generated on either impairment board. Robbed-bit signaling is available on the first link.
- Amplitude jitter and single frequency interference have been added to Model 182.
- New RITT and TR_50150 gain distortions have been added to Models 151, 152, 181, and 182. New RITT1 and RITT2 delay distortions have been added to Models 151, 152, 181, and 182. New recall files for RITT1 and RITT2 have been added to Model 182.
- The TSB37A lines for the 182 are revised to match the most recent specifications dated October 1994.

A1.3. Version 4.10

The following are the changes incorporated into the 100 Series Version 4.10 firmware.

- The 100 Series models are restructured. The new models are the 150, 151, 152, 181, and 182. See section 1.3. TAS 100 Series Product Highlights for the available features of the different models.
- A new menu navigation feature is added to the front panel control. This feature allows the user to return to the previous line of the menu group when switching between menu groups.

- Gain hits and phase hits are added to model 182.
- The TSB37A lines for the 182 are revised to match the most recent specifications dated 8/16/93.
- The measure menu will no longer disrupt the front panel display when performing a /IO,C/ from remote.

A1.4. Version 4.00

The following are the changes incorporated into the 100 Series Version 4.00 firmware.

- The file recall label of EIA 1 to EIA 6 has been changed to EIA496A_L1 to EIA496A_L6.
- 20 new line configurations, TSB37_L7 to TSB37_L16 and EIA_L17a to EIA_L24 are added to the recall list. Refer to section 5.2.1 for a complete listing of the available configuration files.
- In addition to the name change of the EIA 1 to EIA 6 configuration files, they are grouped with the new TSB lines on the front panel display. The remote parameter values are unchanged to maintain compatibility with existing control software.
- Three new gain characteristics are added to the gain and delay shape (LINE Impairment). They are cable1, cable2, and cable3.
- The EIA delay characteristics 1 to 5, the EIA gain characteristics A, B, C, and the flat gain and delay have been enhanced.
- New menus and remote commands are added for PCM simulation.
- New menu parameters and remote commands are added for the support of Disconnect Signal.
- A new model 182 (bidirectional) has been added to the 100 series family.
- Psophometric noise weighting is added to the Noise Level Correction.
- The amount of frequency shift set remotely, that is rounded to the nearest 0.25 Hz increment, is now reflected correctly on the front panel display.
- The external hybrid balance and the loopback relay state displayed on the front panel are corrected to indicate their actual hardware states.
- The input and output power settings of the old EIA 1 to 6 lines are changed. Refer to sections 8.2.2.3 to 8.2.2.8 for the exact settings.
- The central office parameters for the EIA 1 to 6 lines configurations are now the same as the central office parameters for USA Average. See section 8.2.1.19 for more information.

A1.5. Version 3.11

The following are the changes incorporated into the 100 Series Version 3.11 firmware.

- Using the line feed/carriage return (LFCR) protocol did not always respond correctly to all commands. This has been corrected.
- Models that contain the Intermodulation Distortion (IMD) impairment now supports two simulation modes. Refer to section 5.2.1 /AD,Gg/ for more information.
- The Dial tone, Busy, and Ringback frequency component ranges have been expanded. Refer to section 5.2.16 /SG,Fjffff/ for more information.
- A file recall will no longer change the current setting of either the volume level or the monitor point selected.
- On the menu line for setting up the RS-232 control parameters the label BAUD has been changed to RATE.
- On the menu line for file recall, the selection of ALL has been changed to IMP+CO for recalling both the impairment and central office parameters from the specified file.
- The file recall label of WEST GERMANY has been changed to GERMANY.
- When an AGC is performed (either input or output) all white noise sources which are currently on will be turned off for the duration of the AGC. The noise sources will be returned to their previous state at the end of the AGC.

A1.6. Version 3.10

The following are the changes incorporated into the 100 Series Version 3.10 firmware.

- The front panel display shows the various menus and submenus while in the remote mode. You may also scroll through the menus and submenus while in the remote mode.
- Level measurement results can be viewed on the front panel display while the unit is in the remote mode.
- A hold feature on several buttons has been implemented. The action of the button is repeated as long as the button is held down.
- The AGC and measure functions operate more quickly.
- Seven new recallable files are added: Canada, Norway, Singapore, Sweden, Switzerland, Taiwan, Germany.
- The power-up self calibration procedure has been animated on the display to indicate progress during power-up.

- Parameter readback commands have been added to the remote command set to allow the stored value of any parameter to be retrieved upon request. Refer to section 4.3.4.2 parameter value readback for more information.

A1.7. Version 3.01

The following are the changes incorporated into the 100 Series Version 3.01 firmware.

- Error codes 025, 026, and 031 did not stop the calibration process in Version 3.00 firmware. This has been corrected.
- A “parser” syntax error was also corrected. The Version 3.01 firmware will now recognize the syntax error when a command /AD,I2/,S1/ (or /AD,I2/S1/) is sent to the unit.

A1.8. Version 3.00

The following are the changes incorporated into the 100 Series Version 3.00 firmware.

- All 100 series models have the ability to provide reverse polarity (battery) signaling and improved signaling cadence resolution.
- Two new models have been added to the 100 series family. Model 121 (unidirectional) and model 122 (bidirectional) provide three new impairments: phase hits, gain hits, and impulse noise.
- The TAS 101A and 111A models have been removed from the TAS 100 product family. Customers who have ordered either of these models will instead receive a TAS 101 or a TAS 111 unit, respectively. The TAS 101 and TAS 111 include a satellite delay feature.
- The cadence resolution for signaling tones has been enhanced to provide two timing resolution selections: 50 ms increments and 25 ms increments. The two selections are applicable to the on and off timing of ringing, dial tone, busy signal, and ringback.
- The front panel volume adjustment is now active in the remote mode, in addition to being active in the local mode.

A1.9. Version 2.30

The following are the changes incorporated into the 100 Series Version 2.30 firmware.

- The noise level in the B to A simulation direction was set incorrectly when both simulation directions are controlled simultaneously. This has been corrected.
- The bypass operation was revised and will operate as expected.
- The echo simulation is turned off when the unit is changed to 4 wire mode but is not set back on when the unit is returned to 2 wire mode. This has been corrected.
- The amount of frequency shift set remotely, that is rounded to the nearest 0.25 Hz increment, is now reflected correctly on the front panel display.
- The external hybrid balance and the loopback relay state displayed on the front panel are corrected to indicate their actual hardware states.
- The input and output power settings of the old EIA 1 to 6 lines are changed. Refer to sections 8.2.2.3 to 8.2.2.8 for the exact settings.
- The central office parameters for the EIA 1 to 6 lines configurations are now the same as the central office parameters for USA Average. See section 8.2.1.19 for more information.

A1.10. Version 2.20

The following are the changes incorporated into the 100 Series Version 2.20 firmware.

- In version 2.10 firmware, certain key sequences after a recall or save operation caused part of the front panel to lock up and the wrong display to be shown. The bug has been corrected in version 2.20.
- The NTT 1 to 7 characteristics have been renamed as JPN 1 to 7.
- An /AD,Z/ command followed by a /GD,.../ command caused transmission path to be lost. This has been also corrected.
- Correction has been made to the diagnostics that caused intermittent error 29 or error 30.
- The AGC algorithm has been revised to eliminate an intermittent error 015 for high frequency (2 kHz to 3.5 kHz) input signals.

A1.11. Version 2.10

- Version 2.10 corrects the firmware bug that caused problem with measuring signals that are near -20 dBm.

A1.12. Version 2.00

The following are the changes incorporated into the 100 Series Version 3.10 firmware.

- CCITT R.28 gain/delay filter characteristic has been added.
- Dial tone cadence has been added.
- Multiple dial tone has been added.
- Number of user save/recall files is reduced from 10 to 5.
- File number assignments for remote control RECALL files command (/AD,Ccc/) has been changed for files 5 - 17. Refer to section 5.2.1 for more information and a listing of the recall files.
- 8 new recall files have been added: Belgium, EIA 1, EIA 2, EIA 3, EIA 4, EIA 5, EIA 6, and Korea.
- Some recall files have been modified. Refer to section 8.2 for the complete listing and parameters of the recall files.
- The front panel cursor movement has been improved.
- The measurement algorithm averaging time has been reduced.
- The combined AGC execution has been removed from the front panel combined impairment mode.
- The noise calibration has been corrected for power up back with 3k flat weighting selection.

APPENDIX 2: ROM FILE CONTENTS FOR RECALLABLE FILES

Each recallable ROM file contains two sets of parameters - the central office parameters and the impairment parameters. The user can choose to recall only the central office parameters or both the central office and the impairment parameters.

The first section of this appendix outlines the central office parameters of the ROM files. Since some of the files share the same central office parameters, that configuration is listed only once.

The second section of this appendix outlines the impairment parameters of the ROM files. Some configurations have the same impairments in the A→B direction and the B→A direction. In this case, the parameters are listed together. In order for the remote commands to work properly, the impairment control has to be selected correctly. Please refer to section 2.4.1 for more information.

For Model 182, notice that the satellite delay values of the TSB37 and EIA files are different from the round trip delay values specified in the TSB37 and EIA PN 3064 specification. The values in the recall files are calculated by taking into account other residual delays so that the resulting round trip delays are as specified. See section 3.3.7. for more information. The following is a reference mapping of the TAS recall file names to industry specifications:

The second section of this appendix outlines the impairment parameters of the ROM files. Some configurations have the same impairments in the A→B direction and the B→A direction. In this case, the parameters are listed together. In order for the remote commands to work properly, the impairment control has to be selected correctly. Refer to section 2.5.1 for more information.

For Model 182, notice that the satellite delay values of the TSB37 and EIA files are different from the round trip delay values specified in the TSB37 and EIA PN 3064 specification. The values in the recall files are calculated by taking into account other residual delays so that the resulting round trip delays are as specified. See section 3.3.7. for more information. The following is a reference mapping of the TAS recall file names to industry specifications:

TAS RECALL FILE NAME	SPECIFICATION	IMPAIRMENT COMBINATION
EIA496A_L1	EIA/TIA-496-A	Line 1
EIA496A_L2		Line 2
EIA496A_L3		Line 3
EIA496A_L4		Line 4
EIA496A_L5		Line 5
EIA496A_L6		Line 6
TSB37_L7	EIA/TIA-TSB 37	Line 7
TSB37_L8		Line 8
TSB37_L9		Line 9
TSB37_L10		Line 10
TSB37_L11		Line 11
TSB37_L12		Line 12
TSB37_L13		Line 13
TSB37_L14		Line 14
TSB37_L15		Line 15
TSB37_L16	Line 16	
EIA_L17a	EIA/TIA-TSB 37A	Line 17a
EIA_L17b		Line 17b
EIA_L17c		Line 17c
EIA_L18a		Line 18a
EIA_L18b		Line 18b
EIA_L18c		Line 18c
EIA_L19a		Line 19a
EIA_L20a		Line 20a
EIA_L21a	Line 21a	
EIA_L22a	Line 22a	
EIA_L23a	Line 23a	
EIA_L24a	Line 24a	

A2.1. Central Office Parameters

This section lists the central office parameters of the ROM files. The list is in alphabetical order of the ROM files. Parameters shared by multiple files are presented only once.

A2.1.1. Central Office Parameters for Belgium:

CENTRAL OFFICE (Main Menu)	Remote Commands
LINE MODE: <i>switched 2w</i>	/LC,M1/
STATION A#: <i>1</i>	/SW,TA1/
STATION B#: <i>2</i>	/SW,TB2/
LOOP CURRENT: A <i>32mA</i> B <i>32mA</i>	/SG,HA4,HB4/
RINGING: LEVEL <i>75V</i> FREQ <i>25.0Hz</i>	/SG,L75,Y250/
DIAL TONE LEVEL: <i>-10dBm</i>	/SG,D-10/
REVERSE POLARITY SIGNALLING: <i>off</i>	/SG,E0/

CENTRAL OFFICE (Submenu 1)	
LOOP CURRENT POL: A <i>pos</i> B <i>pos</i> ^	/SG,CA0,CB0/
LOOPBACK RELAY: A <i>on</i> B <i>on</i> ^	/LC,XA1,XB1/
PROGRAM RESISTOR: A <i>off</i> B <i>off</i> ^	/LC,YA0,YB0/
EXTERNAL 2W: A>B <i>no</i> B>A <i>no</i> ^	/LC,FA0,FB0/
BALANCE NETWORK: A <i>int</i> B <i>int</i> ^	/LC,BA0,BB0/

CENTRAL OFFICE (Submenu 2)	
DIAL TONE DELAY: <i>100ms</i> ^	/SW,N100/
SWITCHING DELAY: <i>100ms</i> ^	/SW,M100/
ON HOOK DELAY: <i>200ms</i> ^	/SW,Q200/
DISCONNECT SIG: <i>none</i> DLY <i>1ms</i> ^	/SW,R0,L1/

CENTRAL OFFICE (Submenu 3)	
RINGBACK: F1 <i>450.0Hz</i> F2 <i>450.0Hz</i> ^	/SG,FE4500,FF4500/
DIAL TONE: F1 <i>450.0Hz</i> F2 <i>450.0Hz</i> ^	/SG,FA4500,FB4500/
BUSY: F1 <i>450.0Hz</i> F2 <i>450.0Hz</i> ^	/SG,FC4500,FD4500/

CENTRAL OFFICE (Submenu 4)

CADENCE RESOLUTION:	50ms	^	/SG,K0/
RING:	ON1 0ms	OFF1 0ms	^ /SG,RA0,RD0/
RING:	ON2 0ms	OFF2 0ms	^ /SG,RB0,RE0/
RING:	ON3 1000ms	OFF3 3000ms	^ /SG,RC20,RF60/
BUSY:	ON 150ms	OFF 150ms	^ /SG,BA3,BB3/
DIAL:	ON1 0ms	OFF1 0ms	^ /SG,TA0,TD0/
DIAL:	ON2 0ms	OFF2 0ms	^ /SG,TB0,TE0/
DIAL:	ON3 10000ms	OFF3 0ms	^ /SG,TC200,TF0/
PULSE BREAK:	MIN 10ms	MAX 90ms	^ /SG,PA10,PB90/
PULSE MAKE:	MIN 10ms	MAX 90ms	^ /SG,PC10,PD90/

A2.1.2. Central Office Parameters for Canada:

Same as USA Average, see section A2.1.19.

A2.1.3. Central Office Parameters for EIA496A_L1 thru EIA496A_L6:

Same as USA Average, see section A2.1.19.

A2.1.4. Central Office Parameters for Factory Default:

CENTRAL OFFICE (Main Menu)

Remote Commands

LINE MODE: <i>private 4w</i>	/LC,M0/
STATION A#: 5550123	/SW,TA5550123/
STATION B#: 5559876	/SW,TB5559876/
LOOP CURRENT: A 32mA B 32mA	/SG,HA4,HB4/
RINGING: LEVEL 85V FREQ 20.0Hz	/SG,L85,Y200/
DIAL TONE LEVEL: -10dBm	/SG,D-10/
REVERSE POLARITY SIGNALLING: <i>off</i>	/SG,E0/

CENTRAL OFFICE (Submenu 1)

LOOP CURRENT POL:	A <i>pos</i>	B <i>pos</i>	^	/SG,CA0,CB0/
LOOPBACK RELAY:	A <i>on</i>	B <i>on</i>	^	/LC,XA1,XB1/
PROGRAM RESISTOR:	A <i>off</i>	B <i>off</i>	^	/LC,YA0,YB0/
EXTERNAL 2W:	A>B <i>no</i>	B>A <i>no</i>	^	/LC,FA0,FB0/
BALANCE NETWORK:	A <i>int</i>	B <i>int</i>	^	/LC,BA0,BB0/

CENTRAL OFFICE (Submenu 2)

DIAL TONE DELAY:	2ms	^	/SW,N2/
SWITCHING DELAY:	1ms	^	/SW,M1/
ON HOOK DELAY:	255ms	^	/SW,Q255/
DISCONNECT SIG:	<i>none</i> DLY 1ms	^	/SW,R0,L1/

CENTRAL OFFICE (Submenu 3)

RINGBACK:	F1 440.0Hz	F2 480.0Hz	^	/SG,FE4400,FF4800/
DIAL TONE:	F1 350.0Hz	F2 440.0Hz	^	/SG,FA3500,FB4400/
BUSY:	F1 480.0Hz	F2 620.0Hz	^	/SG,FC4800,FD6200/

CENTRAL OFFICE (Submenu 4)

CADENCE RESOLUTION:	50ms		^	/SG,K0/
RING:	ON1 0ms	OFF1 0ms	^	/SG,RA0,RD0/
RING:	ON2 0ms	OFF2 0ms	^	/SG,RB0,RE0/
RING:	ON3 2000ms	OFF3 4000ms	^	/SG,RC40,RF80/
BUSY:	ON 500ms	OFF 500ms	^	/SG,BA10,BB10/
DIAL:	ON1 0ms	OFF1 0ms	^	/SG,TA0,TD0/
DIAL:	ON2 0ms	OFF2 0ms	^	/SG,TB0,TE0/
DIAL:	ON3 10000ms	OFF3 0ms	^	/SG,TC200,TF0/
PULSE BREAK:	MIN 10ms	MAX 90ms	^	/SG,PA10,PB90/
PULSE MAKE:	MIN 10ms	MAX 90ms	^	/SG,PC10,PD90/

*A2.1.5. Central Office Parameters for France:***CENTRAL OFFICE (Main Menu)****Remote Commands**

LINE MODE: <i>switched 2w</i>				/LC,M1/
STATION A#: <i>1</i>				/SW,TA1/
STATION B#: <i>2</i>				/SW,TB2/
LOOP CURRENT: A <i>32mA</i> B <i>32mA</i>				/SG,HA4,HB4/
RINGING: LEVEL <i>70V</i> FREQ <i>50.0Hz</i>				/SG,L70,Y500/
DIAL TONE LEVEL: <i>-25dBm</i>				/SG,D-25/
REVERSE POLARITY SIGNALLING: <i>off</i>				/SG,E0/

CENTRAL OFFICE (Submenu 1)

LOOP CURRENT POL:	A <i>pos</i>	B <i>pos</i>	^	/SG,CA0,CB0/
LOOPBACK RELAY:	A <i>on</i>	B <i>on</i>	^	/LC,XA1,XB1/
PROGRAM RESISTOR:	A <i>off</i>	B <i>off</i>	^	/LC,YA0,YB0/
EXTERNAL 2W:	A>B <i>no</i>	B>A <i>no</i>	^	/LC,FA0,FB0/
BALANCE NETWORK:	A <i>int</i>	B <i>int</i>	^	/LC,BA0,BB0/

CENTRAL OFFICE (Submenu 2)

DIAL TONE DELAY:	100ms		^	/SW,N100/
SWITCHING DELAY:	100ms		^	/SW,M100/
ON HOOK DELAY:	200ms		^	/SW,Q200/
DISCONNECT SIG:	<i>none</i>	DLY <i>1ms</i>	^	/SW,R0,L1/

CENTRAL OFFICE (Submenu 3)

RINGBACK:	F1 440.0Hz	F2 440.0Hz	^	/SG,FE4400,FF4400/
DIAL TONE:	F1 440.0Hz	F2 440.0Hz	^	/SG,FA4400,FB4400/
BUSY:	F1 440.0Hz	F2 440.0Hz	^	/SG,FC4400,FD4400/

CENTRAL OFFICE (Submenu 4)

CADENCE RESOLUTION:	50ms		^	/SG,K0/
RING:	ON1 0ms	OFF1 0ms	^	/SG,RA0,RD0/
RING:	ON2 0ms	OFF2 0ms	^	/SG,RB0,RE0/
RING:	ON3 1500ms	OFF3 3500ms	^	/SG,RC30,RF70/
BUSY:	ON 500ms	OFF 500ms	^	/SG,BA10,BB10/
DIAL:	ON1 0ms	OFF1 0ms	^	/SG,TA0,TD0/
DIAL:	ON2 0ms	OFF2 0ms	^	/SG,TB0,TE0/
DIAL:	ON3 10000ms	OFF3 0ms	^	/SG,TC200,TF0/
PULSE BREAK:	MIN 10ms	MAX 90ms	^	/SG,PA10,PB90/
PULSE MAKE:	MIN 10ms	MAX 90ms	^	/SG,PC10,PD90/

A2.1.6. Central Office Parameters for Germany:

CENTRAL OFFICE (Main Menu)

Remote Commands

LINE MODE: <i>switched 2w</i>	/LC,M1/
STATION A#: <i>1</i>	/SW,TA1/
STATION B#: <i>2</i>	/SW,TB2/
LOOP CURRENT: A <i>48mA</i> B <i>48mA</i>	/SG,HA6,HB6/
RINGING: LEVEL <i>85V</i> FREQ <i>25.0Hz</i>	/SG,L85,Y250/
DIAL TONE LEVEL: <i>-10dBm</i>	/SG,D-10/
REVERSE POLARITY SIGNALLING: <i>off</i>	/SG,E0/

CENTRAL OFFICE (Submenu 1)

LOOP CURRENT POL:	A <i>pos</i>	B <i>pos</i>	^	/SG,CA0,CB0/
LOOPBACK RELAY:	A <i>on</i>	B <i>on</i>	^	/LC,XA1,XB1/
PROGRAM RESISTOR:	A <i>on</i>	B <i>on</i>	^	/LC,YA1,YB1/
EXTERNAL 2W:	A>B <i>no</i>	B>A <i>no</i>	^	/LC,FA0,FB0/
BALANCE NETWORK:	A <i>int</i>	B <i>int</i>	^	/LC,BA0,BB0/

CENTRAL OFFICE (Submenu 2)

DIAL TONE DELAY:	100ms		^	/SW,N100/
SWITCHING DELAY:	100ms		^	/SW,M100/
ON HOOK DELAY:	200ms		^	/SW,Q200/
DISCONNECT SIG:	<i>none</i>	DLY <i>1ms</i>	^	/SW,R0,L1/

CENTRAL OFFICE (Submenu 3)

RINGBACK:	F1 425.0Hz	F2 425.0Hz	^	/SG,FE4250,FF4250/
DIAL TONE:	F1 425.0Hz	F2 425.0Hz	^	/SG,FA4250,FB4250/
BUSY:	F1 425.0Hz	F2 425.0Hz	^	/SG,FC4250,FD4250/

CENTRAL OFFICE (Submenu 4)

CADENCE RESOLUTION:	50ms	^	/SG,K0/
RING:	ON1 0ms OFF1 0ms	^	/SG,RA0,RD0/
RING:	ON2 0ms OFF2 0ms	^	/SG,RB0,RE0/
RING:	ON3 950ms OFF3 3850ms	^	/SG,RC19,RF50/
BUSY:	ON 500ms OFF 500ms	^	/SG,BA10,BB10/
DIAL:	ON1 0ms OFF1 0ms	^	/SG,TA0,TD0/
DIAL:	ON2 0ms OFF2 0ms	^	/SG,TB0,TE0/
DIAL:	ON3 10000ms OFF3 0ms	^	/SG,TC200,TF0/
PULSE BREAK:	MIN 10ms MAX 90ms	^	/SG,PA10,PB90/
PULSE MAKE:	MIN 10ms MAX 90ms	^	/SG,PC10,PD90/

A2.1.7. Central Office Parameters for Great Britain:**CENTRAL OFFICE (Main Menu)****Remote Commands**

LINE MODE: <i>switched 2w</i>	/LC,M1/
STATION A#: <i>1</i>	/SW,TA1/
STATION B#: <i>2</i>	/SW,TB2/
LOOP CURRENT: A <i>32mA</i> B <i>32mA</i>	/SG,HA4,HB4/
RINGING: LEVEL <i>70V</i> FREQ <i>16.7Hz</i>	/SG,L70,Y167/
DIAL TONE LEVEL: <i>-13dBm</i>	/SG,D-13/
REVERSE POLARITY SIGNALLING: <i>off</i>	/SG,E0/

CENTRAL OFFICE (Submenu 1)

LOOP CURRENT POL:	A <i>pos</i> B <i>pos</i>	^	/SG,CA0,CB0/
LOOPBACK RELAY:	A <i>on</i> B <i>on</i>	^	/LC,XA1,XB1/
PROGRAM RESISTOR:	A <i>off</i> B <i>off</i>	^	/LC,YA0,YB0/
EXTERNAL 2W:	A>B <i>no</i> B>A <i>no</i>	^	/LC,FA0,FB0/
BALANCE NETWORK:	A <i>int</i> B <i>int</i>	^	/LC,BA0,BB0/

CENTRAL OFFICE (Submenu 2)

DIAL TONE DELAY:	100ms	^	/SW,N100/
SWITCHING DELAY:	100ms	^	/SW,M100/
ON HOOK DELAY:	200ms	^	/SW,Q200/
DISCONNECT SIG:	<i>none</i> DLY <i>1ms</i>	^	/SW,R0,L1/

CENTRAL OFFICE (Submenu 3)

RINGBACK:	F1 400.0Hz F2 450.0Hz	^	/SG,FE4000,FF4500/
DIAL TONE:	F1 350.0Hz F2 440.0Hz	^	/SG,FA3500,FB4400/
BUSY:	F1 400.0Hz F2 400.0Hz	^	/SG,FC4000,FD4000/

CENTRAL OFFICE (Submenu 4)

CADENCE RESOLUTION:	50ms	^	/SG,K0/	
RING:	ON1 0ms	OFF1 0ms	^	/SG,RA0,RD0/
RING:	ON2 400ms	OFF2 200ms	^	/SG,RB8,RE4/
RING:	ON3 400ms	OFF3 2000ms	^	/SG,RC8,RF4/
BUSY:	ON 400ms	OFF 400ms	^	/SG,BA8,BB8/
DIAL:	ON1 0ms	OFF1 0ms	^	/SG,TA0,TD0/
DIAL:	ON2 0ms	OFF2 0ms	^	/SG,TB0,TE0/
DIAL:	ON3 10000ms	OFF3 0ms	^	/SG,TC200,TF0/
PULSE BREAK:	MIN 10ms	MAX 90ms	^	/SG,PA10,PB90/
PULSE MAKE:	MIN 10ms	MAX 90ms	^	/SG,PC10,PD90/

A2.1.8. Central Office Parameters for Italy:**CENTRAL OFFICE (Main Menu)****Remote Commands**

LINE MODE: <i>switched 2w</i>	/LC,M1/
STATION A#: 1	/SW,TA1/
STATION B#: 2	/SW,TB2/
LOOP CURRENT: A 32mA B 32mA	/SG,HA4,HB4/
RINGING: LEVEL 70V FREQ 25.0Hz	/SG,L70,Y250/
DIAL TONE LEVEL: -10dBm	/SG,D-10/
REVERSE POLARITY SIGNALLING: <i>off</i>	/SG,E0/

CENTRAL OFFICE (Submenu 1)

LOOP CURRENT POL:	A <i>pos</i>	B <i>pos</i>	^	/SG,CA0,CB0/
LOOPBACK RELAY:	A <i>on</i>	B <i>on</i>	^	/LC,XA1,XB1/
PROGRAM RESISTOR:	A <i>off</i>	B <i>off</i>	^	/LC,YA0,YB0/
EXTERNAL 2W:	A>B <i>no</i>	B>A <i>no</i>	^	/LC,FA0,FB0/
BALANCE NETWORK:	A <i>int</i>	B <i>int</i>	^	/LC,BA0,BB0/

CENTRAL OFFICE (Submenu 2)

DIAL TONE DELAY:	100ms	^	/SW,N100/
SWITCHING DELAY:	100ms	^	/SW,M100/
ON HOOK DELAY:	200ms	^	/SW,Q200/
DISCONNECT SIG:	<i>none</i> DLY 1ms	^	/SW,R0,L1/

CENTRAL OFFICE (Submenu 3)

RINGBACK:	F1 425.0Hz	F2 425.0Hz	^	/SG,FE4250,FF4250/
DIAL TONE:	F1 425.0Hz	F2 425.0Hz	^	/SG,FA4250,FB4250/
BUSY:	F1 425.0Hz	F2 425.0Hz	^	/SG,FC4250,FD4250/

CENTRAL OFFICE (Submenu 4)

CADENCE RESOLUTION:	50ms		^	/SG,K0/
RING:	ON1 0ms	OFF1 0ms	^	/SG,RA0,RD0/
RING:	ON2 0ms	OFF2 0ms	^	/SG,RB0,RE0/
RING:	ON3 1000ms	OFF3 4000ms	^	/SG,RC20,RF80/
BUSY:	ON 200ms	OFF 200ms	^	/SG,BA4,BB4/
DIAL:	ON1 0ms	OFF1 0ms	^	/SG,TA0,TD0/
DIAL:	ON2 600ms	OFF2 1000ms	^	/SG,TB12,TE20/
DIAL:	ON3 200ms	OFF3 200ms	^	/SG,TC4,TF4/
PULSE BREAK:	MIN 10ms	MAX 90ms	^	/SG,PA10,PB90/
PULSE MAKE:	MIN 10ms	MAX 90ms	^	/SG,PC10,PD90/

A2.1.9. Central Office Parameters for Japan:**CENTRAL OFFICE (Main Menu)****Remote Commands**

LINE MODE: <i>switched 2w</i>	/LC,M1/
STATION A#: <i>1</i>	/SW,TA1/
STATION B#: <i>2</i>	/SW,TB2/
LOOP CURRENT: A <i>32mA</i> B <i>32mA</i>	/SG,HA4,HB4/
RINGING: LEVEL <i>75V</i> FREQ <i>17.5Hz</i>	/SG,L75,Y175/
DIAL TONE LEVEL: <i>-20dBm</i>	/SG,D-20/
REVERSE POLARITY SIGNALLING: <i>off</i>	/SG,E0/

CENTRAL OFFICE (Submenu 1)

LOOP CURRENT POL:	A <i>pos</i>	B <i>pos</i>	^	/SG,CA0,CB0/
LOOPBACK RELAY:	A <i>on</i>	B <i>on</i>	^	/LC,XA1,XB1/
PROGRAM RESISTOR:	A <i>off</i>	B <i>off</i>	^	/LC,YA0,YB0/
EXTERNAL 2W:	A>B <i>no</i>	B>A <i>no</i>	^	/LC,FA0,FB0/
BALANCE NETWORK:	A <i>int</i>	B <i>int</i>	^	/LC,BA0,BB0/

CENTRAL OFFICE (Submenu 2)

DIAL TONE DELAY:	100ms		^	/SW,N100/
SWITCHING DELAY:	100ms		^	/SW,M100/
ON HOOK DELAY:	200ms		^	/SW,Q200/
DISCONNECT SIG:	<i>none</i>	DLY <i>1ms</i>	^	/SW,R0,L1/

CENTRAL OFFICE (Submenu 3)

RINGBACK:	F1 400.0Hz	F2 416.0Hz	^	/SG,FE4000,FF4160/
DIAL TONE:	F1 400.0Hz	F2 400.0Hz	^	/SG,FA4000,FB4000/
BUSY:	F1 400.0Hz	F2 400.0Hz	^	/SG,FC4000,FD4000/

CENTRAL OFFICE (Submenu 4)

CADENCE RESOLUTION:	50ms	^	/SG,K0/
RING:	ON1 0ms	OFF1 0ms	^ /SG,RA0,RD0/
RING:	ON2 0ms	OFF2 0ms	^ /SG,RB0,RE0/
RING:	ON3 1000ms	OFF3 2000ms	^ /SG,RC20,RF40/
BUSY:	ON 500ms	OFF 500ms	^ /SG,BA10,BB10/
DIAL:	ON1 0ms	OFF1 0ms	^ /SG,TA0,TD0/
DIAL:	ON2 0ms	OFF2 0ms	^ /SG,TB0,TE0/
DIAL:	ON3 10000ms	OFF3 0ms	^ /SG,TC200,TF0/
PULSE BREAK:	MIN 10ms	MAX 90ms	^ /SG,PA10,PB90/
PULSE MAKE:	MIN 10ms	MAX 90ms	^ /SG,PC10,PD90/

A2.1.10. Central Office Parameters for Korea:

CENTRAL OFFICE (Main Menu)

Remote Commands

LINE MODE: <i>switched 2w</i>	/LC,M1/
STATION A#: <i>1</i>	/SW,TA1/
STATION B#: <i>2</i>	/SW,TB2/
LOOP CURRENT: A <i>32mA</i> B <i>32mA</i>	/SG,HA4,HB4/
RINGING: LEVEL <i>70V</i> FREQ <i>16.7Hz</i>	/SG,L70,Y167/
DIAL TONE LEVEL: <i>-13dBm</i>	/SG,D-13/
REVERSE POLARITY SIGNALLING: <i>off</i>	/SG,E0/

CENTRAL OFFICE (Submenu 1)

LOOP CURRENT POL:	A <i>pos</i>	B <i>pos</i>	^	/SG,CA0,CB0/
LOOPBACK RELAY:	A <i>on</i>	B <i>on</i>	^	/LC,XA1,XB1/
PROGRAM RESISTOR:	A <i>off</i>	B <i>off</i>	^	/LC,YA0,YB0/
EXTERNAL 2W:	A>B <i>no</i>	B>A <i>no</i>	^	/LC,FA0,FB0/
BALANCE NETWORK:	A <i>int</i>	B <i>int</i>	^	/LC,BA0,BB0/

CENTRAL OFFICE (Submenu 2)

DIAL TONE DELAY:	100ms	^	/SW,N100/
SWITCHING DELAY:	100ms	^	/SW,M100/
ON HOOK DELAY:	200ms	^	/SW,Q200/
DISCONNECT SIG:	<i>none</i> DLY <i>1ms</i>	^	/SW,R0,L1/

CENTRAL OFFICE (Submenu 3)

RINGBACK:	F1 440.0Hz	F2 480.0Hz	^	/SG,FE4400,FF4800/
DIAL TONE:	F1 350.0Hz	F2 440.0Hz	^	/SG,FA3500,FB4400/
BUSY:	F1 480.0Hz	F2 620.0Hz	^	/SG,FC4800,FD6200/

CENTRAL OFFICE (Submenu 4)

CADENCE RESOLUTION:	50ms		^	/SG,K0/
RING:	ON1 0ms	OFF1 0ms	^	/SG,RA0,RD0/
RING:	ON2 0ms	OFF2 0ms	^	/SG,RB0,RE0/
RING:	ON3 1000ms	OFF3 2000ms	^	/SG,RC20,RF40/
BUSY:	ON 500ms	OFF 500ms	^	/SG,BA10,BB10/
DIAL:	ON1 0ms	OFF1 0ms	^	/SG,TA0,TD0/
DIAL:	ON2 0ms	OFF2 0ms	^	/SG,TB0,TE0/
DIAL:	ON3 10000ms	OFF3 0ms	^	/SG,TC200,TF0/
PULSE BREAK:	MIN 10ms	MAX 90ms	^	/SG,PA10,PB90/
PULSE MAKE:	MIN 10ms	MAX 90ms	^	/SG,PC10,PD90/

*A2.1.11. Central Office Parameters for Netherlands:***CENTRAL OFFICE (Main Menu)****Remote Commands**

LINE MODE: <i>switched 2w</i>				/LC,M1/
STATION A#: <i>1</i>				/SW,TA1/
STATION B#: <i>2</i>				/SW,TB2/
LOOP CURRENT: A <i>32mA</i> B <i>32mA</i>				/SG,HA4,HB4/
RINGING: LEVEL <i>75V</i> FREQ <i>25.0Hz</i>				/SG,L75,Y250/
DIAL TONE LEVEL: <i>-10dBm</i>				/SG,D-10/
REVERSE POLARITY SIGNALLING: <i>off</i>				/SG,E0/

CENTRAL OFFICE (Submenu 1)

LOOP CURRENT POL:	A <i>pos</i>	B <i>pos</i>	^	/SG,CA0,CB0/
LOOPBACK RELAY:	A <i>on</i>	B <i>on</i>	^	/LC,XA1,XB1/
PROGRAM RESISTOR:	A <i>off</i>	B <i>off</i>	^	/LC,YA0,YB0/
EXTERNAL 2W:	A>B <i>no</i>	B>A <i>no</i>	^	/LC,FA0,FB0/
BALANCE NETWORK:	A <i>int</i>	B <i>int</i>	^	/LC,BA0,BB0/

CENTRAL OFFICE (Submenu 2)

DIAL TONE DELAY:	100ms		^	/SW,N100/
SWITCHING DELAY:	100ms		^	/SW,M100/
ON HOOK DELAY:	200ms		^	/SW,Q200/
DISCONNECT SIG:	<i>none</i>	DLY <i>1ms</i>	^	/SW,R0,L1/

CENTRAL OFFICE (Submenu 3)

RINGBACK:	F1 425.0Hz	F2 425.0Hz	^	/SG,FE4250,FF4250/
DIAL TONE:	F1 150.0Hz	F2 450.0Hz	^	/SG,FA1500,FB4500/
BUSY:	F1 425.0Hz	F2 425.0Hz	^	/SG,FC4250,FD4250/

CENTRAL OFFICE (Submenu 4)

CADENCE RESOLUTION:	50ms	^	/SG,K0/
RING:	ON1 0ms OFF1 0ms	^	/SG,RA0,RD0/
RING:	ON2 0ms OFF2 0ms	^	/SG,RB0,RE0/
RING:	ON3 1000ms OFF3 4000ms	^	/SG,RC20,RF80/
BUSY:	ON 500ms OFF 500ms	^	/SG,BA10,BB10/
DIAL:	ON1 0ms OFF1 0ms	^	/SG,TA0,TD0/
DIAL:	ON2 0ms OFF2 0ms	^	/SG,TB0,TE0/
DIAL:	ON3 10000ms OFF3 0ms	^	/SG,TC200,TF0/
PULSE BREAK:	MIN 10ms MAX 90ms	^	/SG,PA10,PB90/
PULSE MAKE:	MIN 10ms MAX 90ms	^	/SG,PC10,PD90/

A2.1.12. Central Office Parameters for Norway:

CENTRAL OFFICE (Main Menu)

Remote Commands

LINE MODE: <i>switched 2w</i>	/LC,M1/
STATION A#: <i>1</i>	/SW,TA1/
STATION B#: <i>2</i>	/SW,TB2/
LOOP CURRENT: A <i>48mA</i> B <i>48mA</i>	/SG,HA6,HB6/
RINGING: LEVEL <i>85V</i> FREQ <i>25.0Hz</i>	/SG,L85,Y250/
DIAL TONE LEVEL: <i>-10dBm</i>	/SG,D-10/
REVERSE POLARITY SIGNALLING: <i>off</i>	/SG,E0/

CENTRAL OFFICE (Submenu 1)

LOOP CURRENT POL:	A <i>pos</i> B <i>pos</i>	^	/SG,CA0,CB0/
LOOPBACK RELAY:	A <i>on</i> B <i>on</i>	^	/LC,XA1,XB1/
PROGRAM RESISTOR:	A <i>on</i> B <i>on</i>	^	/LC,YA1,YB1/
EXTERNAL 2W:	A>B <i>no</i> B>A <i>no</i>	^	/LC,FA0,FB0/
BALANCE NETWORK:	A <i>int</i> B <i>int</i>	^	/LC,BA0,BB0/

CENTRAL OFFICE (Submenu 2)

DIAL TONE DELAY:	100ms	^	/SW,N100/
SWITCHING DELAY:	100ms	^	/SW,M100/
ON HOOK DELAY:	200ms	^	/SW,Q200/
DISCONNECT SIG:	<i>none</i> DLY <i>1ms</i>	^	/SW,R0,L1/

CENTRAL OFFICE (Submenu 3)

RINGBACK:	F1 440.0Hz F2 480.0Hz	^	/SG,FE4400,FF4800/
DIAL TONE:	F1 425.0Hz F2 425.0Hz	^	/SG,FA4250,FB4250/
BUSY:	F1 400.0Hz F2 400.0Hz	^	/SG,FC4000,FD4000/

CENTRAL OFFICE (Submenu 4)

CADENCE RESOLUTION:	50ms	^	/SG,K0/
RING:	ON1 0ms OFF1 0ms	^	/SG,RA0,RD0/
RING:	ON2 0ms OFF2 0ms	^	/SG,RB0,RE0/
RING:	ON3 1000ms OFF3 4000ms	^	/SG,RC20,RF80/
BUSY:	ON 200ms OFF 400ms	^	/SG,BA4,BB8/
DIAL:	ON1 0ms OFF1 0ms	^	/SG,TA0,TD0/
DIAL:	ON2 0ms OFF2 0ms	^	/SG,TB0,TE0/
DIAL:	ON3 10000ms OFF3 0ms	^	/SG,TC200,TF0/
PULSE BREAK:	MIN 10ms MAX 90ms	^	/SG,PA10,PB90/
PULSE MAKE:	MIN 10ms MAX 90ms	^	/SG,PC10,PD90/

A2.1.13. Central Office Parameters for RITT1:**CENTRAL OFFICE (Main Menu)****Remote Commands**

LINE MODE: <i>switched 2w</i>	/LC,M1/
STATION A#: <i>1</i>	/SW,TA1/
STATION B#: <i>2</i>	/SW,TB2/
LOOP CURRENT: A <i>48mA</i> B <i>48mA</i>	/SG,HA6,HB6/
RINGING: LEVEL <i>85V</i> FREQ <i>25.0Hz</i>	/SG,L85,Y250/
DIAL TONE LEVEL: <i>-13dBm</i>	/SG,D-13/
REVERSE POLARITY SIGNALLING: <i>off</i>	/SG,E0/

CENTRAL OFFICE (Submenu 1)

LOOP CURRENT POL:	A <i>pos</i> B <i>pos</i>	^	/SG,CA0,CB0/
LOOPBACK RELAY:	A <i>on</i> B <i>on</i>	^	/LC,XA1,XB1/
PROGRAM RESISTOR:	A <i>off</i> B <i>off</i>	^	/LC,YA0,YB0/
EXTERNAL 2W:	A>B <i>no</i> B>A <i>no</i>	^	/LC,FA0,FB0/
BALANCE NETWORK:	A <i>int</i> B <i>int</i>	^	/LC,BA0,BB0/

CENTRAL OFFICE (Submenu 2)

DIAL TONE DELAY:	2ms	^	/SW,N2/
SWITCHING DELAY:	1ms	^	/SW,M1/
ON HOOK DELAY:	255ms	^	/SW,Q255/
DISCONNECT SIG:	<i>none</i> DLY <i>1ms</i>	^	/SW,R0,L1/

CENTRAL OFFICE (Submenu 3)

RINGBACK:	F1 450.0Hz F2 450.0Hz	^	/SG,FE4500,FF4500/
DIAL TONE:	F1 450.0Hz F2 450.0Hz	^	/SG,FA4500,FB4500/
BUSY:	F1 450.0Hz F2 450.0Hz	^	/SG,FC4500,FD4500/

CENTRAL OFFICE (Submenu 4)

CADENCE RESOLUTION:	50ms	^	/SG,K0/
RING:	ON1 0ms	OFF1 0ms	^ /SG,RA0,RD0/
RING:	ON2 0ms	OFF2 0ms	^ /SG,RB0,RE0/
RING:	ON3 1000ms	OFF3 4000ms	^ /SG,RC20,RF80/
BUSY:	ON 350ms	OFF 350ms	^ /SG,BA7,BB7/
DIAL:	ON1 0ms	OFF1 0ms	^ /SG,TA0,TD0/
DIAL:	ON2 0ms	OFF2 0ms	^ /SG,TB0,TE0/
DIAL:	ON3 60000ms	OFF3 0ms	^ /SG,TC1200,TF0/
PULSE BREAK:	MIN 10ms	MAX 90ms	^ /SG,PA10,PB90/
PULSE MAKE:	MIN 10ms	MAX 90ms	^ /SG,PC10,PD90/

A2.1.14. Central Office Parameters for RITT2:

Same as RITT1, see section A.2.1.13

A2.1.15. Central Office Parameters for Singapore:

CENTRAL OFFICE (Main Menu)

Remote Commands

LINE MODE: <i>switched 2w</i>	/LC,M1/
STATION A#: <i>1</i>	/SW,TA1/
STATION B#: <i>2</i>	/SW,TB2/
LOOP CURRENT: A <i>48mA</i> B <i>48mA</i>	/SG,HA6,HB6/
RINGING: LEVEL <i>85V</i> FREQ <i>20.0Hz</i>	/SG,L85,Y200/
DIAL TONE LEVEL: <i>-10dBm</i>	/SG,D-10/
REVERSE POLARITY SIGNALLING: <i>off</i>	/SG,E0/

CENTRAL OFFICE (Submenu 1)

LOOP CURRENT POL:	A <i>pos</i>	B <i>pos</i>	^	/SG,CA0,CB0/
LOOPBACK RELAY:	A <i>on</i>	B <i>on</i>	^	/LC,XA1,XB1/
PROGRAM RESISTOR:	A <i>on</i>	B <i>on</i>	^	/LC,YA1,YB1/
EXTERNAL 2W:	A>B <i>no</i>	B>A <i>no</i>	^	/LC,FA0,FB0/
BALANCE NETWORK:	A <i>int</i>	B <i>int</i>	^	/LC,BA0,BB0/

CENTRAL OFFICE (Submenu 2)

DIAL TONE DELAY:	100ms	^	/SW,N100/
SWITCHING DELAY:	100ms	^	/SW,M100/
ON HOOK DELAY:	200ms	^	/SW,Q200/
DISCONNECT SIG:	<i>none</i> DLY <i>1ms</i>	^	/SW,R0,L1/

CENTRAL OFFICE (Submenu 3)

RINGBACK:	F1 400.0Hz	F2 424.0Hz	^	/SG,FE4000,FF4240/
DIAL TONE:	F1 400.0Hz	F2 424.0Hz	^	/SG,FA4000,FB4240/
BUSY:	F1 400.0Hz	F2 400.0Hz	^	/SG,FC4000,FD4000/

CENTRAL OFFICE (Submenu 4)

CADENCE RESOLUTION:	50ms	^	/SG,K0/
RING:	ON1 0ms	OFF1 0ms	^ /SG,RA0,RD0/
RING:	ON2 400ms	OFF2 200ms	^ /SG,RB8,RE4/
RING:	ON3 400ms	OFF3 2000ms	^ /SG,RC8,RF40/
BUSY:	ON 750ms	OFF 750ms	^ /SG,BA15,BB15/
DIAL:	ON1 0ms	OFF1 0ms	^ /SG,TA0,TD0/
DIAL:	ON2 0ms	OFF2 0ms	^ /SG,TB0,TE0/
DIAL:	ON3 10000ms	OFF3 0ms	^ /SG,TC200,TF0/
PULSE BREAK:	MIN 10ms	MAX 90ms	^ /SG,PA10,PB90/
PULSE MAKE:	MIN 10ms	MAX 90ms	^ /SG,PC10,PD90/

A2.1.16. Central Office Parameters for Sweden:

CENTRAL OFFICE (Main Menu)**Remote Commands**

LINE MODE: <i>switched 2w</i>	/LC,M1/
STATION A#: <i>1</i>	/SW,TA1/
STATION B#: <i>2</i>	/SW,TB2/
LOOP CURRENT: A <i>48mA</i> B <i>48mA</i>	/SG,HA6,HB6/
RINGING: LEVEL <i>85V</i> FREQ <i>20.0Hz</i>	/SG,L85,Y200/
DIAL TONE LEVEL: <i>-10dBm</i>	/SG,D-10/
REVERSE POLARITY SIGNALLING: <i>off</i>	/SG,E0/

CENTRAL OFFICE (Submenu 1)

LOOP CURRENT POL:	A <i>pos</i>	B <i>pos</i>	^	/SG,CA0,CB0/
LOOPBACK RELAY:	A <i>on</i>	B <i>on</i>	^	/LC,XA1,XB1/
PROGRAM RESISTOR:	A <i>on</i>	B <i>on</i>	^	/LC,YA1,YB1/
EXTERNAL 2W:	A>B <i>no</i>	B>A <i>no</i>	^	/LC,FA0,FB0/
BALANCE NETWORK:	A <i>int</i>	B <i>int</i>	^	/LC,BA0,BB0/

CENTRAL OFFICE (Submenu 2)

DIAL TONE DELAY:	100ms	^	/SW,N100/
SWITCHING DELAY:	100ms	^	/SW,M100/
ON HOOK DELAY:	200ms	^	/SW,Q200/
DISCONNECT SIG:	<i>none</i> DLY <i>1ms</i>	^	/SW,R0,L1/

CENTRAL OFFICE (Submenu 3)

RINGBACK:	F1 425.0Hz	F2 425.0Hz	^	/SG,FE4250,FF4250/
DIAL TONE:	F1 425.0Hz	F2 425.0Hz	^	/SG,FA4250,FB4250/
BUSY:	F1 425.0Hz	F2 425.0Hz	^	/SG,FC4250,FD4250/

CENTRAL OFFICE (Submenu 4)

CADENCE RESOLUTION:	50ms	^	/SG,K0/
RING:	ON1 0ms	OFF1 0ms	^ /SG,RA0,RD0/
RING:	ON2 0ms	OFF2 0ms	^ /SG,RB0,RE0/
RING:	ON3 1000ms	OFF3 5000ms	^ /SG,RC20,RF100/
BUSY:	ON 250ms	OFF 250ms	^ /SG,BA5,BB5/
DIAL:	ON1 0ms	OFF1 0ms	^ /SG,TA0,TD0/
DIAL:	ON2 0ms	OFF2 0ms	^ /SG,TB0,TE0/
DIAL:	ON3 10000ms	OFF3 0ms	^ /SG,TC200,TF0/
PULSE BREAK:	MIN 10ms	MAX 90ms	^ /SG,PA10,PB90/
PULSE MAKE:	MIN 10ms	MAX 90ms	^ /SG,PC10,PD90/

A2.1.17. Central Office Parameters for Switzerland:**CENTRAL OFFICE (Main Menu)****Remote Commands**

LINE MODE: <i>switched 2w</i>	/LC,M1/
STATION A#: <i>1</i>	/SW,TA1/
STATION B#: <i>2</i>	/SW,TB2/
LOOP CURRENT: A <i>48mA</i> B <i>48mA</i>	/SG,HA6,HB6/
RINGING: LEVEL <i>85V</i> FREQ <i>25.0Hz</i>	/SG,L85,Y250/
DIAL TONE LEVEL: <i>-10dBm</i>	/SG,D-10/
REVERSE POLARITY SIGNALLING: <i>off</i>	/SG,E0/

CENTRAL OFFICE (Submenu 1)

LOOP CURRENT POL:	A <i>pos</i>	B <i>pos</i>	^	/SG,CA0,CB0/
LOOPBACK RELAY:	A <i>on</i>	B <i>on</i>	^	/LC,XA1,XB1/
PROGRAM RESISTOR:	A <i>on</i>	B <i>on</i>	^	/LC,YA1,YB1/
EXTERNAL 2W:	A>B <i>no</i>	B>A <i>no</i>	^	/LC,FA0,FB0/
BALANCE NETWORK:	A <i>int</i>	B <i>int</i>	^	/LC,BA0,BB0/

CENTRAL OFFICE (Submenu 2)

DIAL TONE DELAY:	100ms	^	/SW,N100/
SWITCHING DELAY:	100ms	^	/SW,M100/
ON HOOK DELAY:	200ms	^	/SW,Q200/
DISCONNECT SIG:	<i>none</i> DLY <i>1ms</i>	^	/SW,R0,L1/

CENTRAL OFFICE (Submenu 3)

RINGBACK:	F1 425.0Hz	F2 425.0Hz	^	/SG,FE4250,FF4250/
DIAL TONE:	F1 425.0Hz	F2 425.0Hz	^	/SG,FA4250,FB4250/
BUSY:	F1 425.0Hz	F2 425.0Hz	^	/SG,FC4250,FD4250/

CENTRAL OFFICE (Submenu 4)

CADENCE RESOLUTION:	50ms	^	/SG,K0/
RING:	ON1 0ms	OFF1 0ms	^ /SG,RA0,RD0/
RING:	ON2 0ms	OFF2 0ms	^ /SG,RB0,RE0/
RING:	ON3 1000ms	OFF3 4000ms	^ /SG,RC20,RF80/
BUSY:	ON 500ms	OFF 500ms	^ /SG,BA10,BB10/
DIAL:	ON1 0ms	OFF1 0ms	^ /SG,TA0,TD0/
DIAL:	ON2 0ms	OFF2 0ms	^ /SG,TB0,TE0/
DIAL:	ON3 10000ms	OFF3 0ms	^ /SG,TC200,TF0/
PULSE BREAK:	MIN 10ms	MAX 90ms	^ /SG,PA10,PB90/
PULSE MAKE:	MIN 10ms	MAX 90ms	^ /SG,PC10,PD90/

A2.1.18. Central Office Parameters for Taiwan:**CENTRAL OFFICE (Main Menu)****Remote Commands**

LINE MODE: <i>switched 2w</i>	/LC,M1/
STATION A#: <i>1</i>	/SW,TA1/
STATION B#: <i>2</i>	/SW,TB2/
LOOP CURRENT: A <i>48mA</i> B <i>48mA</i>	/SG,HA6,HB6/
RINGING: LEVEL <i>85V</i> FREQ <i>20.0Hz</i>	/SG,L85,Y200/
DIAL TONE LEVEL: <i>-10dBm</i>	/SG,D-10/
REVERSE POLARITY SIGNALLING: <i>off</i>	/SG,E0/

CENTRAL OFFICE (Submenu 1)

LOOP CURRENT POL:	A <i>pos</i>	B <i>pos</i>	^	/SG,CA0,CB0/
LOOPBACK RELAY:	A <i>on</i>	B <i>on</i>	^	/LC,XA1,XB1/
PROGRAM RESISTOR:	A <i>on</i>	B <i>on</i>	^	/LC,YA1,YB1/
EXTERNAL 2W:	A>B <i>no</i>	B>A <i>no</i>	^	/LC,FA0,FB0/
BALANCE NETWORK:	A <i>int</i>	B <i>int</i>	^	/LC,BA0,BB0/

CENTRAL OFFICE (Submenu 2)

DIAL TONE DELAY:	100ms	^	/SW,N100/
SWITCHING DELAY:	100ms	^	/SW,M100/
ON HOOK DELAY:	200ms	^	/SW,Q200/
DISCONNECT SIG:	<i>none</i> DLY <i>1ms</i>	^	/SW,R0,L1/

CENTRAL OFFICE (Submenu 3)

RINGBACK:	F1 440.0Hz	F2 480.0Hz	^	/SG,FE4400,FF4800/
DIAL TONE:	F1 350.0Hz	F2 440.0Hz	^	/SG,FA3500,FB4400/
BUSY:	F1 480.0Hz	F2 620.0Hz	^	/SG,FC4800,FD6200/

CENTRAL OFFICE (Submenu 4)

CADENCE RESOLUTION:	50ms	^	/SG,K0/
RING:	ON1 0ms	OFF1 0ms	^ /SG,RA0,RD0/
RING:	ON2 0ms	OFF2 0ms	^ /SG,RB0,RE0/
RING:	ON3 2000ms	OFF3 4000ms	^ /SG,RC40,RF80/
BUSY:	ON 500ms	OFF 500ms	^ /SG,BA10,BB10/
DIAL:	ON1 0ms	OFF1 0ms	^ /SG,TA0,TD0/
DIAL:	ON2 0ms	OFF2 0ms	^ /SG,TB0,TE0/
DIAL:	ON3 10000ms	OFF3 0ms	^ /SG,TC200,TF0/
PULSE BREAK:	MIN 10ms	MAX 90ms	^ /SG,PA10,PB90/
PULSE MAKE:	MIN 10ms	MAX 90ms	^ /SG,PC10,PD90/

A2.1.19 Central Office Parameters for TSB37_L7 thru TSB37_L16 [182]:

Same as USA Average, except the HYBRID BALANCE NETWORK A and B are EXTERNAL instead of INTERNAL, see section A2.1.21.

A2.1.20 Central Office Parameters for EIA_L17a thru EIA_L24 [182]:

Same as USA Average, except the HYBRID BALANCE NETWORK A and B are EXTERNAL instead of INTERNAL, see section A2.1.21.

A2.1.21. Central Office Parameters for USA Average:

CENTRAL OFFICE (Main Menu)

Remote Commands

LINE MODE: <i>switched 2w</i>	/LC,M1/
STATION A#: 1	/SW,TA1/
STATION B#: 2	/SW,TB2/
LOOP CURRENT: A 40mA B 40mA	/SG,HA5,HB5/
RINGING: LEVEL 85V FREQ 20.0Hz	/SG,L85,Y200/
DIAL TONE LEVEL: -10dBm	/SG,D-10/
REVERSE POLARITY SIGNALLING: <i>off</i>	/SG,E0/

CENTRAL OFFICE (Submenu 1)

LOOP CURRENT POL:	A <i>pos</i>	B <i>pos</i>	^	/SG,CA0,CB0/
LOOPBACK RELAY:	A <i>on</i>	B <i>on</i>	^	/LC,XA1,XB1/
PROGRAM RESISTOR:	A <i>off</i>	B <i>off</i>	^	/LC,YA1,YB1/
EXTERNAL 2W:	A>B <i>no</i>	B>A <i>no</i>	^	/LC,FA0,FB0/
BALANCE NETWORK:	A <i>int</i>	B <i>int</i>	^	/LC,BA0,BB0/

CENTRAL OFFICE (Submenu 2)

DIAL TONE DELAY:	100ms	^	/SW,N100/
SWITCHING DELAY:	100ms	^	/SW,M100/
ON HOOK DELAY:	200ms	^	/SW,Q200/
DISCONNECT SIG:	<i>none</i> DLY 1ms	^	/SW,R0,L1/

CENTRAL OFFICE (Submenu 3)

RINGBACK:	F1 440.0Hz	F2 480.0Hz	^	/SG,FE4400,FF4800/
DIAL TONE:	F1 350.0Hz	F2 440.0Hz	^	/SG,FA3500,FB4400/
BUSY:	F1 480.0Hz	F2 620.0Hz	^	/SG,FC4800,FD6200/

CENTRAL OFFICE (Submenu 4)

CADENCE RESOLUTION:		50ms	^	/SG,K0/		
RING:	ON1	0ms	OFF1	0ms	^	/SG,RA0,RD0/
RING:	ON2	0ms	OFF2	0ms	^	/SG,RB0,RE0/
RING:	ON3	2000ms	OFF3	4000ms	^	/SG,RC40,RF80/
BUSY:	ON	500ms	OFF	500ms	^	/SG,BA10,BB10/
DIAL:	ON1	0ms	OFF1	0ms	^	/SG,TA0,TD0/
DIAL:	ON2	0ms	OFF2	0ms	^	/SG,TB0,TE0/
DIAL:	ON3	10000ms	OFF3	0ms	^	/SG,TC200,TF0/
PULSE BREAK:	MIN	10ms	MAX	90ms	^	/SG,PA10,PB90/
PULSE MAKE:	MIN	10ms	MAX	90ms	^	/SG,PC10,PD90/

A2.1.22. Central Office Parameters for USA Worst Case:

Same as USA Average, see section A.2.1.21

A2.2. Impairment Parameters

This section contains the impairment parameters of the ROM files. The list is in alphabetical order of the ROM files. Parameters shared by multiple files are presented only once.

In some configurations where the impairments are the same in the A→B and the B→A direction, the parameters are listed together. Some impairment parameters apply only to certain models of the TAS 100 Series; refer to section 2.2.1. Menu Summary for the available parameters for your model.

A2.2.1. Impairment Parameters for Belgium:

A→B and B→A IMPAIRMENTS (Main Menu)				Remote Commands
LINE:	<i>m1025</i>	NOISE:	<i>on</i>	35.0dBm /GD,V71;/RN,S1,L350/
INLVL:	<i>-10.0dBm</i>	OUTLVL:		-23.0dBm /IO,I-100,L-230/
IMD:	<i>off</i>	2nd	<i>52.0dB</i>	3rd <i>50.0dB</i> /NL,S0,Q520,C500/
FREQ SHIFT:	<i>off</i>		<i>0.00Hz</i>	/FS,S0,F0/
AJ:	<i>off</i>	LVL	<i>10.0%</i>	FREQ <i>60.00Hz</i> /AJ,S0,L100,F6000/
PJ:	<i>off</i>	LVL	<i>0.0deg</i>	FREQ <i>60.00Hz</i> /PJ,S0,L0,F6000/
SATELLITE DELAY:	<i>off</i>			<i>550.000ms</i> /SD,S0,D4400/
PCM:	<i>off</i>	LINKS	<i>1</i>	CODING <i>mu-law</i> /PC,S0,L1,C0/
PCM:		RBS	<i>off</i>	POSITION <i>last</i> /PC,R0,P0/
GHIT:	<i>off</i>	LVL	<i>3.0dB</i>	INT <i>1.0s</i> /GH,S0,L30,I10/
GHIT:		DUR	<i>5ms</i>	RISE <i>0.2ms</i> /GH,D5,R2/
PHIT:	<i>off</i>	LVL	<i>45.0deg</i>	INT <i>1.0s</i> /PH,S0,L450,I10/
PHIT:		DUR	<i>5ms</i>	RISE <i>0.2ms</i> /PH,D5,R2/
IMP:	<i>off</i>	LVL	<i>40.0dB</i>	rel <i>27.0dBm</i> /TM,S0,L400/
IMP:		INT	<i>1.0s</i>	/TM,I10/
SFI:	<i>off</i>	LVL	<i>10.0dB</i>	FREQ <i>2600Hz</i> /SF,S0,L100,F2600/

A→B and B→A IMPAIRMENTS (Submenu)

CUSTOM LINE: GAIN TYPE	<i>flat</i>	^	/GD,W0/
CUSTOM LINE: DELAY TYPE	<i>flat</i>	^	/GD,Y0/
NOISE LEVEL CORRECTION:	<i>c-msg</i>	^	/RN,W0/
IMD MODE:	<i>expansive</i>	^	/NL,M0/

CENTRAL OFFICE (Submenu 5)

A ECHO:	<i>off</i>	NEAR	<i>21.0dB</i>	POL <i>pos</i>	^	/EC,SA0,LA210,PA0/
A ECHO:		FAR	<i>21.0dB</i>	POL <i>pos</i>	^	/EC,LB210,PB0/
B ECHO:	<i>off</i>	NEAR	<i>21.0dB</i>	POL <i>pos</i>	^	/EC,SB0,LC210,PC0/
B ECHO:		FAR	<i>21.0dB</i>	POL <i>pos</i>	^	/EC,LD210,PD0/

A2.2.2. Impairment Parameters for Canada:

Same as Belgium, see section A2.2.1. Impairment Parameters for Belgium.

A2.2.3. Impairment Parameters for EIA496A_L1:

A→B and B→A IMPAIRMENTS (Main Menu)				Remote Commands	
LINE:	<i>eia_a1</i>	NOISE:	<i>on</i> 40.0dBm	/GD,V9/;/RN,S1,L400/	
INLVL:	<i>-10.0dBm</i>	OUTLVL:	<i>-25.0dBm</i>	/IO,I-100,L-250/	
IMD:	<i>on</i>	2nd	<i>42.0dB</i>	3rd <i>40.0dB</i>	/NL,S1,Q420,C400/
FREQ SHIFT:	<i>off</i>		<i>0.00Hz</i>	/FS,S0,F0/	
AJ:	<i>off</i>	LVL	<i>10.0%</i>	FREQ <i>60.00Hz</i>	/AJ,S0,L100,F6000/
PJ:	<i>on</i>	LVL	<i>15.0deg</i>	FREQ <i>20.00Hz</i>	/PJ,S1,L150,F2000/
SATELLITE DELAY:	<i>off</i>		<i>550.000ms</i>	/SD,S0,D4400/	
PCM:	<i>off</i>	LINKS 1		CODING <i>mu-law</i>	/PC,S0,L1,C0/
PCM:		RBS	<i>off</i>	POSITION <i>last</i>	/PC,R0,P0/
GHIT:	<i>off</i>	LVL	<i>3.0dB</i>	INT <i>1.0s</i>	/GH,S0,L30,I10/
GHIT:		DUR	<i>5ms</i>	RISE <i>0.2ms</i>	/GH,D5,R2/
PHIT:	<i>off</i>	LVL	<i>45.0deg</i>	INT <i>1.0s</i>	/PH,S0,L450,I10/
PHIT:		DUR	<i>5ms</i>	RISE <i>0.2ms</i>	/PH,D5,R2/
IMP:	<i>off</i>	LVL	<i>40.0dB</i>	rel <i>25.0dBm</i>	/IM,S0,L400/
IMP:		INT	<i>1.0s</i>		/IM,I10/
SFI:	<i>off</i>	LVL	<i>10.0dB</i>	FREQ <i>2600Hz</i>	/SF,S0,L100,F2600/

A→B and B→A IMPAIRMENTS (Submenu)

CUSTOM LINE: GAIN TYPE	<i>flat</i>	^	/GD,W0/
CUSTOM LINE: DELAY TYPE	<i>flat</i>	^	/GD,Y0/
NOISE LEVEL CORRECTION:	<i>c-msg</i>	^	/RN,W0/
IMD MODE:	<i>expansive</i>	^	/NL,M0/

CENTRAL OFFICE (Submenu 5)

A ECHO:	<i>off</i>	NEAR	<i>21.0dB</i>	POL <i>pos</i>	^	/EC,SA0,LA210,PA0/
A ECHO:		FAR	<i>21.0dB</i>	POL <i>pos</i>	^	/EC,LB210,PB0/
B ECHO:	<i>off</i>	NEAR	<i>21.0dB</i>	POL <i>pos</i>	^	/EC,SB0,LC210,PC0/
B ECHO:		FAR	<i>21.0dB</i>	POL <i>pos</i>	^	/EC,LD210,PD0/

A2.2.4. Impairment Parameters for EIA496A_L2:

A→B and B→A IMPAIRMENTS (Main Menu)				Remote Commands	
LINE:	<i>eia_c2</i>	NOISE:	<i>on 36.0dBm</i>	/GD,V7/;/RN,S1,L360/	
INLVL:	<i>-10.0dBm</i>	OUTLVL:	<i>-30.0dBm</i>	/IO,I-100,L-300/	
IMD:	<i>on</i>	2nd	<i>42.0dB</i>	3rd <i>40.0dB</i>	/NL,S1,Q420,C400/
FREQ SHIFT:	<i>off</i>		<i>0.00Hz</i>	/FS,S0,F0/	
AJ:	<i>off</i>	LVL	<i>10.0%</i>	FREQ <i>60.00Hz</i>	/AJ,S0,L100,F6000/
PJ:	<i>on</i>	LVL	<i>5.0deg</i>	FREQ <i>60.00Hz</i>	/PJ,S1,L50,F6000/
SATELLITE DELAY:	<i>off</i>		<i>550.000ms</i>	/SD,S0,D4400/	
PCM:	<i>off</i>	LINKS 1		CODING <i>mu-law</i>	/PC,S0,L1,C0/
PCM:		RBS	<i>off</i>	POSITION <i>last</i>	/PC,R0,P0/
GHIT:	<i>off</i>	LVL	<i>3.0dB</i>	INT <i>1.0s</i>	/GH,S0,L30,I10/
GHIT:		DUR	<i>5ms</i>	RISE <i>0.2ms</i>	/GH,D5,R2/
PHIT:	<i>off</i>	LVL	<i>45.0deg</i>	INT <i>1.0s</i>	/PH,S0,L450,I10/
PHIT:		DUR	<i>5ms</i>	RISE <i>0.2ms</i>	/PH,D5,R2/
IMP:	<i>off</i>	LVL	<i>40.0dB</i>	rel <i>20.0dBm</i>	/IM,S0,L400/
IMP:		INT	<i>1.0s</i>		/IM,I10/
SFI:	<i>off</i>	LVL	<i>10.0dB</i>	FREQ <i>2600Hz</i>	/SF,S0,L100,F2600/

A→B and B→A IMPAIRMENTS (Submenu)

CUSTOM LINE: GAIN TYPE	<i>flat</i>	^	/GD,W0/
CUSTOM LINE: DELAY TYPE	<i>flat</i>	^	/GD,Y0/
NOISE LEVEL CORRECTION:	<i>c-msg</i>	^	/RN,W0/
IMD MODE:	<i>expansive</i>	^	/NL,M0/

CENTRAL OFFICE (Submenu 5)

A ECHO:	<i>off</i>	NEAR	<i>21.0dB</i>	POL <i>pos</i>	^	/EC,SA0,LA210,PA0/
A ECHO:		FAR	<i>21.0dB</i>	POL <i>pos</i>	^	/EC,LB210,PB0/
B ECHO:	<i>off</i>	NEAR	<i>21.0dB</i>	POL <i>pos</i>	^	/EC,SB0,LC210,PC0/
B ECHO:		FAR	<i>21.0dB</i>	POL <i>pos</i>	^	/EC,LD210,PD0/

A2.2.5. Impairment Parameters for EIA496A_L3:

A→B and B→A IMPAIRMENTS (Main Menu)				Remote Commands
LINE:	<i>eia_b3</i>	NOISE: <i>on</i>	32.0dBm	/GD,V11/; /RN,S1,L320/
INLVL:	<i>-10.0dBm</i>	OUTLVL:	<i>-36.0dBm</i>	/IO,I-100,L-360/
IMD:	<i>on</i>	2nd <i>40.0dB</i>	3rd <i>38.0dB</i>	/NL,S1,Q400,C380/
FREQ SHIFT:	<i>off</i>	<i>0.00Hz</i>		/FS,S0,F0/
AJ:	<i>off</i>	LVL <i>10.0%</i>	FREQ <i>60.00Hz</i>	/AJ,S0,L100,F6000/
PJ:	<i>on</i>	LVL <i>10.0deg</i>	FREQ <i>120.00Hz</i>	/PJ,S1,L100,F12000/
SATELLITE DELAY:	<i>off</i>		<i>550.000ms</i>	/SD,S0,D4400/
PCM:	<i>off</i>	LINKS <i>1</i>	CODING <i>mu-law</i>	/PC,S0,L1,C0/
PCM:		RBS <i>off</i>	POSITION <i>last</i>	/PC,R0,P0/
GHIT:	<i>off</i>	LVL <i>3.0dB</i>	INT <i>1.0s</i>	/GH,S0,L30,I10/
GHIT:		DUR <i>5ms</i>	RISE <i>0.2ms</i>	/GH,D5,R2/
PHIT:	<i>off</i>	LVL <i>45.0deg</i>	INT <i>1.0s</i>	/PH,S0,L450,I10/
PHIT:		DUR <i>5ms</i>	RISE <i>0.2ms</i>	/PH,D5,R2/
IMP:	<i>off</i>	LVL <i>40.0dB</i>	rel <i>14.0dBm</i>	/IM,S0,L400/
IMP:		INT <i>1.0s</i>		/IM,I10/
SFI:	<i>off</i>	LVL <i>10.0dB</i>	FREQ <i>2600Hz</i>	/SF,S0,L100,F2600/

A→B and B→A IMPAIRMENTS (Submenu)

CUSTOM LINE: GAIN TYPE	<i>flat</i>	^	/GD,W0/
CUSTOM LINE: DELAY TYPE	<i>flat</i>	^	/GD,Y0/
NOISE LEVEL CORRECTION:	<i>c-msg</i>	^	/RN,W0/
IMD MODE:	<i>expansive</i>	^	/NL,M0/

CENTRAL OFFICE (Submenu 5)

A ECHO:	<i>off</i>	NEAR <i>21.0dB</i>	POL <i>pos</i>	^	/EC,SA0,LA210,PA0/
A ECHO:		FAR <i>21.0dB</i>	POL <i>pos</i>	^	/EC,LB210,PB0/
B ECHO:	<i>off</i>	NEAR <i>21.0dB</i>	POL <i>pos</i>	^	/EC,SB0,LC210,PC0/
B ECHO:		FAR <i>21.0dB</i>	POL <i>pos</i>	^	/EC,LD210,PD0/

A2.2.6. Impairment Parameters for EIA496A_L4:

A→B and B→A IMPAIRMENTS (Main Menu)				Remote Commands
LINE:	<i>eia_b4</i>	NOISE:	<i>on</i>	30.0dBm /GD,V12/; /RN,S1,L300/
INLVL:	<i>-10.0dBm</i>	OUTLVL:	<i>-40.0dBm</i>	/IO,I-100,L-400/
IMD:	<i>on</i>	2nd	<i>42.0dB</i>	3rd <i>40.0dB</i> /NL,S1,Q420,C400/
FREQ SHIFT:	<i>on</i>		<i>-1.00Hz</i>	/FS,S1,F-100/
AJ:	<i>off</i>	LVL	<i>10.0%</i>	FREQ <i>60.00Hz</i> /AJ,S0,L100,F6000/
PJ:	<i>on</i>	LVL	<i>5.0deg</i>	FREQ <i>120.00Hz</i> /PJ,S1,L50,F12000/
SATELLITE DELAY:	<i>off</i>		<i>550.000ms</i>	/SD,S0,D4400/
PCM:	<i>off</i>	LINKS	<i>1</i>	CODING <i>mu-law</i> /PC,S0,L1,C0/
PCM:	<i>off</i>	RBS	<i>off</i>	POSITION <i>last</i> /PC,R0,P0/
GHIT:	<i>off</i>	LVL	<i>3.0dB</i>	INT <i>1.0s</i> /GH,S0,L30,I10/
GHIT:	<i>off</i>	DUR	<i>5ms</i>	RISE <i>0.2ms</i> /GH,D5,R2/
PHIT:	<i>off</i>	LVL	<i>45.0deg</i>	INT <i>1.0s</i> /PH,S0,L450,I10/
PHIT:	<i>off</i>	DUR	<i>5ms</i>	RISE <i>0.2ms</i> /PH,D5,R2/
IMP:	<i>off</i>	LVL	<i>40.0dB</i>	rel <i>10.0dBm</i> /IM,S0,L400/
IMP:	<i>off</i>	INT	<i>1.0s</i>	/IM,I10/
SFI:	<i>off</i>	LVL	<i>10.0dB</i>	FREQ <i>2600Hz</i> /SF,S0,L100,F2600/

A→B and B→A IMPAIRMENTS (Submenu)

CUSTOM LINE: GAIN TYPE	<i>flat</i>	^	/GD,W0/
CUSTOM LINE: DELAY TYPE	<i>flat</i>	^	/GD,Y0/
NOISE LEVEL CORRECTION:	<i>c-msg</i>	^	/RN,W0/
IMD MODE:	<i>expansive</i>	^	/NL,M0/

CENTRAL OFFICE (Submenu 5)

A ECHO:	<i>off</i>	NEAR	<i>21.0dB</i>	POL <i>pos</i>	^	/EC,SA0,LA210,PA0/
A ECHO:	<i>off</i>	FAR	<i>21.0dB</i>	POL <i>pos</i>	^	/EC,LB210,PB0/
B ECHO:	<i>off</i>	NEAR	<i>21.0dB</i>	POL <i>pos</i>	^	/EC,SB0,LC210,PC0/
B ECHO:	<i>off</i>	FAR	<i>21.0dB</i>	POL <i>pos</i>	^	/EC,LD210,PD0/

A2.2.7. Impairment Parameters for EIA496A_L5:

A→B and B→A IMPAIRMENTS (Main Menu)				Remote Commands	
LINE:	<i>eia_b5</i>	NOISE:	<i>on</i> 36.0dBm	/GD,V13;/RN,S1,L360/	
INLVL:	<i>-10.0dBm</i>	OUTLVL:	<i>-32.0dBm</i>	/IO,I-100,L-320/	
IMD:	<i>on</i>	2nd	<i>42.0dB</i>	3rd <i>40.0dB</i>	/NL,S1,Q420,C400/
FREQ SHIFT:	<i>on</i>		<i>1.00Hz</i>	/FS,S1,F100/	
AJ:	<i>off</i>	LVL	<i>10.0%</i>	FREQ <i>60.00Hz</i>	/AJ,S0,L100,F6000/
PJ:	<i>on</i>	LVL	<i>10.0deg</i>	FREQ <i>60.00Hz</i>	/PJ,S1,L100,F6000/
SATELLITE DELAY:	<i>off</i>			<i>550.000ms</i>	/SD,S0,D4400/
PCM:	<i>off</i>	LINKS	<i>1</i>	CODING <i>mu-law</i>	/PC,S0,L1,C0/
PCM:		RBS	<i>off</i>	POSITION <i>last</i>	/PC,R0,P0/
GHIT:	<i>off</i>	LVL	<i>3.0dB</i>	INT <i>1.0s</i>	/GH,S0,L30,I10/
GHIT:		DUR	<i>5ms</i>	RISE <i>0.2ms</i>	/GH,D5,R2/
PHIT:	<i>off</i>	LVL	<i>45.0deg</i>	INT <i>1.0s</i>	/PH,S0,L450,I10/
PHIT:		DUR	<i>5ms</i>	RISE <i>0.2ms</i>	/PH,D5,R2/
IMP:	<i>off</i>	LVL	<i>40.0dB</i>	rel <i>18.0dBm</i>	/IM,S0,L400/
IMP:		INT	<i>1.0s</i>		/IM,I10/
SFI:	<i>off</i>	LVL	<i>10.0dB</i>	FREQ <i>2600Hz</i>	/SF,S0,L100,F2600/

A→B and B→A IMPAIRMENTS (Submenu)

CUSTOM LINE: GAIN TYPE	<i>flat</i>	^	/GD,W0/
CUSTOM LINE: DELAY TYPE	<i>flat</i>	^	/GD,Y0/
NOISE LEVEL CORRECTION:	<i>c-msg</i>	^	/RN,W0/
IMD MODE:	<i>expansive</i>	^	/NL,M0/

CENTRAL OFFICE (Submenu 5)

A ECHO:	<i>off</i>	NEAR	<i>21.0dB</i>	POL <i>pos</i>	^	/EC,SA0,LA210,PA0/
A ECHO:		FAR	<i>21.0dB</i>	POL <i>pos</i>	^	/EC,LB210,PB0/
B ECHO:	<i>off</i>	NEAR	<i>21.0dB</i>	POL <i>pos</i>	^	/EC,SB0,LC210,PC0/
B ECHO:		FAR	<i>21.0dB</i>	POL <i>pos</i>	^	/EC,LD210,PD0/

A2.2.8. Impairment Parameters for EIA496A_L6:

A→B and B→A IMPAIRMENTS (Main Menu)				Remote Commands
LINE:	<i>eia_b2</i>	NOISE: <i>on</i>	38.0dBm	/GD,V10/; /RN,S1,L380/
INLVL:	<i>-10.0dBm</i>	OUTLVL:	<i>-26.0dBm</i>	/IO,I-100,L-260/
IMD:	<i>on</i>	2nd <i>53.0dB</i>	3rd <i>53.0dB</i>	/NL,S0,Q530,C530/
FREQ SHIFT:	<i>off</i>	<i>0.00Hz</i>		/FS,S0,F0/
AJ:	<i>off</i>	LVL <i>10.0%</i>	FREQ <i>60.00Hz</i>	/AJ,S0,L100,F6000/
PJ:	<i>on</i>	LVL <i>5.0de</i>	FREQ <i>120.00Hz</i>	/PJ,S1,L50,F12000/
SATELLITE DELAY:	<i>off</i>		<i>550.000ms</i>	/SD,S0,D4400/
PCM:	<i>off</i>	LINKS <i>1</i>	CODING <i>mu-law</i>	/PC,S0,L1,C0/
PCM:		RBS <i>off</i>	POSITION <i>last</i>	/PC,R0,P0/
GHIT:	<i>off</i>	LVL <i>3.0dB</i>	INT <i>1.0s</i>	/GH,S0,L30,I10/
GHIT:		DUR <i>5ms</i>	RISE <i>0.2ms</i>	/GH,D5,R2/
PHIT:	<i>off</i>	LVL <i>45.0deg</i>	INT <i>1.0s</i>	/PH,S0,L450,I10/
PHIT:		DUR <i>5ms</i>	RISE <i>0.2ms</i>	/PH,D5,R2/
IMP:	<i>off</i>	LVL <i>40.0dB</i>	rel <i>24.0dBm</i>	/IM,S0,L400/
IMP:		INT <i>1.0s</i>		/IM,I10/
SFI:	<i>off</i>	LVL <i>10.0dB</i>	FREQ <i>2600Hz</i>	/SF,S0,L100,F2600/

A→B and B→A IMPAIRMENTS (Submenu)			
CUSTOM LINE: GAIN TYPE	<i>flat</i>	^	/GD,W0/
CUSTOM LINE: DELAY TYPE	<i>flat</i>	^	/GD,Y0/
NOISE LEVEL CORRECTION:	<i>c-msg</i>	^	/RN,W0/
IMD MODE:	<i>expansive</i>	^	/NL,M0/

CENTRAL OFFICE (Submenu 5)				
A ECHO:	<i>off</i>	NEAR <i>21.0dB</i>	POL <i>pos</i> ^	/EC,SA0,LA210,PA0/
A ECHO:		FAR <i>21.0dB</i>	POL <i>pos</i> ^	/EC,LB210,PB0/
B ECHO:	<i>off</i>	NEAR <i>21.0dB</i>	POL <i>pos</i> ^	/EC,SB0,LC210,PC0/
B ECHO:		FAR <i>21.0dB</i>	POL <i>pos</i> ^	/EC,LD210,PD0/

A2.2.9. Impairment Parameters for Factory Default:

A→B and B→A IMPAIRMENTS (Main Menu)				Remote Commands	
LINE:	<i>flat</i>	NOISE:	<i>off 32.0dBm</i>	/GD,V0/; /RN,S0,L320/	
INLVL:	<i>-10.0dBm</i>	OUTLVL:	<i>-18.0dBm</i>	/IO,I-100,L-180/	
IMD:	<i>off</i>	2nd	<i>52.0dB</i>	3rd <i>50.0dB</i>	/NL,S0,Q520,C500/
FREQ SHIFT:	<i>off</i>		<i>0.00Hz</i>	/FS,S0,F0/	
AJ:	<i>off</i>	LVL	<i>10.0%</i>	FREQ <i>60.00Hz</i>	/AJ,S0,L100,F6000/
PJ:	<i>off</i>	LVL	<i>0.0deg</i>	FREQ <i>60.00Hz</i>	/PJ,S0,L0,F6000/
SATELLITE DELAY:	<i>off</i>		<i>550.000ms</i>	/SD,S0,D4400/	
PCM:	<i>off</i>	LINKS	<i>1</i>	CODING <i>mu-law</i>	/PC,S0,L1,C0/
PCM:		RBS	<i>off</i>	POSITION <i>last</i>	/PC,R0,P0/
GHIT:	<i>off</i>	LVL	<i>3.0dB</i>	INT <i>1.0s</i>	/GH,S0,L30,I10/
GHIT:		DUR	<i>5ms</i>	RISE <i>0.2ms</i>	/GH,D5,R2/
PHIT:	<i>off</i>	LVL	<i>45.0deg</i>	INT <i>1.0s</i>	/PH,S0,L450,I10/
PHIT:		DUR	<i>5ms</i>	RISE <i>0.2ms</i>	/PH,D5,R2/
IMP:	<i>off</i>	LVL	<i>40.0dB</i>	rel <i>32.0dBm</i>	/TM,S0,L400/
IMP:		INT	<i>1.0s</i>		/TM,I10/
SFI:	<i>off</i>	LVL	<i>10.0dB</i>	FREQ <i>2600Hz</i>	/SF,S0,L100,F2600/

A→B and B→A IMPAIRMENTS (Submenu)

CUSTOM LINE: GAIN TYPE	<i>flat</i>	^	/GD,W0/
CUSTOM LINE: DELAY TYPE	<i>flat</i>	^	/GD,Y0/
NOISE LEVEL CORRECTION:	<i>c-msg</i>	^	/RN,W0/
IMD MODE:	<i>expansive</i>	^	/NL,M0/

CENTRAL OFFICE (Submenu 5)

A ECHO:	<i>off</i>	NEAR	<i>21.0dB</i>	POL <i>pos</i>	^	/EC,SA0,LA210,PA0/
A ECHO:		FAR	<i>21.0dB</i>	POL <i>pos</i>	^	/EC,LB210,PB0/
B ECHO:	<i>off</i>	NEAR	<i>21.0dB</i>	POL <i>pos</i>	^	/EC,SB0,LC210,PC0/
B ECHO:		FAR	<i>21.0dB</i>	POL <i>pos</i>	^	/EC,LD210,PD0/

A2.2.10. Impairment Parameters for the Following Countries:

France	Germany	Great Britain	Italy
Japan	Korea	Netherlands	Norway
Singapore	Sweden	Switzerland	Taiwan

The impairment parameters for the above countries are the same as Belgium. See section A2.2.1. Impairment Parameters for Belgium for the listing.

A2.2.11. Impairment Parameters for RITT1:

A→B IMPAIRMENTS (Main Menu)				Remote Commands	
LINE:	<i>ritt1</i>	NOISE:	<i>on 36.0dBm</i>	/GD,V55/;/RN,S1,L360/	
INLVL:	<i>-13.0dBm</i>	OUTLVL:	<i>-30.0dBm</i>	/IO,I-130,L-300/	
IMD:	<i>on</i>	2nd	<i>30.0dB</i>	3rd <i>30.0dB</i>	/NL,S0,Q300,C300/
FREQ SHIFT:	<i>on</i>		<i>0.50Hz</i>	/FS,S1,F50/	
AJ:	<i>off</i>	LVL	<i>10.0%</i>	FREQ <i>60.00Hz</i>	/AJ,S0,L100,F6000/
PJ:	<i>on</i>	LVL	<i>10.0deg</i>	FREQ <i>60.00Hz</i>	/PJ,S0,L100,F6000/
SATELLITE DELAY:	<i>off</i>		<i>550.000ms</i>	/SD,S0,D4400/	
PCM:	<i>off</i>	LINKS	<i>1</i>	CODING <i>mu-law</i>	/PC,S0,L1,C0/
PCM:		RBS	<i>off</i>	POSITION <i>last</i>	/PC,R0,P0/
GHIT:	<i>off</i>	LVL	<i>3.0dB</i>	INT <i>1.0s</i>	/GH,S0,L30,I10/
GHIT:		DUR	<i>5ms</i>	RISE <i>0.2ms</i>	/GH,D5,R2/
PHIT:	<i>off</i>	LVL	<i>45.0deg</i>	INT <i>1.0s</i>	/PH,S0,L450,I10/
PHIT:		DUR	<i>5ms</i>	RISE <i>0.2ms</i>	/PH,D5,R2/
IMP:	<i>off</i>	LVL	<i>40.0dB</i>	rel <i>32.0dBm</i>	/IM,S0,L400/
IMP:		INT	<i>1.0s</i>		/IM,I10/
SFI:	<i>on</i>	LVL	<i>30.0dB</i>	FREQ <i>2600Hz</i>	/SF,S1,L300,F2600/

A→B IMPAIRMENTS (Submenu)			
CUSTOM LINE: GAIN TYPE	<i>flat</i>	^	/GD,W0/
CUSTOM LINE: DELAY TYPE	<i>flat</i>	^	/GD,Y0/
NOISE LEVEL CORRECTION:	<i>c-msg</i>	^	/RN,W0/
IMD MODE:	<i>expansive</i>	^	/NL,M0/

B→A IMPAIRMENTS (Main Menu)				Remote Commands	
LINE:	<i>flat</i>	NOISE:	<i>off 36.0dBm</i>	/GD,V0/;/RN,S0,L360/	
INLVL:	<i>-13.0dBm</i>	OUTLVL:	<i>-30.0dBm</i>	/IO,I-130,L-300/	
IMD:	<i>off</i>	2nd	<i>30.0dB</i>	3rd <i>30.0dB</i>	/NL,S0,Q300,C300/
FREQ SHIFT:	<i>off</i>		<i>0.00Hz</i>	/FS,S0,F0/	
AJ:	<i>off</i>	LVL	<i>10.0%</i>	FREQ <i>60.00Hz</i>	/AJ,S0,L100,F6000/
PJ:	<i>off</i>	LVL	<i>0.0deg</i>	FREQ <i>60.00Hz</i>	/PJ,S0,L0,F6000/
SATELLITE DELAY:	<i>off</i>		<i>550.000ms</i>	/SD,S0,D4400/	
PCM:	<i>off</i>	LINKS	<i>1</i>	CODING <i>mu-law</i>	/PC,S0,L1,C0/
PCM:		RBS	<i>off</i>	POSITION <i>last</i>	/PC,R0,P0/
GHIT:	<i>off</i>	LVL	<i>3.0dB</i>	INT <i>1.0s</i>	/GH,S0,L30,I10/
GHIT:		DUR	<i>5ms</i>	RISE <i>0.2ms</i>	/GH,D5,R2/
PHIT:	<i>off</i>	LVL	<i>45.0deg</i>	INT <i>1.0s</i>	/PH,S0,L450,I10/
PHIT:		DUR	<i>5ms</i>	RISE <i>0.2ms</i>	/PH,D5,R2/
IMP:	<i>off</i>	LVL	<i>40.0dB</i>	rel <i>32.0dBm</i>	/IM,S0,L400/
IMP:		INT	<i>1.0s</i>		/IM,I10/
SFI:	<i>off</i>	LVL	<i>10.0dB</i>	FREQ <i>2600Hz</i>	/SF,S0,L100,F2600/

B→A IMPAIRMENTS (Submenu)

CUSTOM LINE: GAIN TYPE	<i>flat</i>	^	/GD,W0/
CUSTOM LINE: DELAY TYPE	<i>flat</i>	^	/GD,Y0/
NOISE LEVEL CORRECTION:	<i>c-msg</i>	^	/RN,W0/
IMD MODE:	<i>expansive</i>	^	/NL,M0/

CENTRAL OFFICE (Submenu 5)

A ECHO:	<i>off</i>	NEAR 21.0dB	POL <i>pos</i>	^	/EC,SA0,LA210,PA0/
A ECHO:		FAR 21.0dB	POL <i>pos</i>	^	/EC,LB210,PB0/
B ECHO:	<i>off</i>	NEAR 21.0dB	POL <i>pos</i>	^	/EC,SB0,LC210,PC0/
B ECHO:		FAR 21.0dB	POL <i>pos</i>	^	/EC,LD210,PD0/

A2.2.12. Impairment Parameters for RITT2:**A→B IMPAIRMENTS (Main Menu)****Remote Commands**

LINE:	<i>ritt2</i>	NOISE: <i>on</i>	30.0dBm	/GD,V56/; /RN,S1,L300/
INLVL:	<i>-10.0dBm</i>	OUTLVL:	<i>-30.0dBm</i>	/IO,I-100,L-300/
IMD:	<i>on</i>	2nd 35.0dB	3rd 35.0dB	/NL,S0,Q350,C350/
FREQ SHIFT:	<i>on</i>	0.50Hz		/FS,S1,F50/
AJ:	<i>off</i>	LVL 10.0%	FREQ 60.00Hz	/AJ,S0,L100,F6000/
PJ:	<i>on</i>	LVL 10.0de	FREQ 60.00Hz	/PJ,S0,L100,F6000/
SATELLITE DELAY:	<i>off</i>		550.000ms	/SD,S0,D4400/
PCM:	<i>off</i>	LINKS 1	CODING <i>mu-law</i>	/PC,S0,L1,C0/
PCM:		RBS <i>off</i>	POSITION <i>last</i>	/PC,R0,P0/
GHIT:	<i>off</i>	LVL 3.0dB	INT 1.0s	/GH,S0,L30,I10/
GHIT:		DUR 5ms	RISE 0.2ms	/GH,D5,R2/
PHIT:	<i>off</i>	LVL 45.0deg	INT 1.0s	/PH,S0,L450,I10/
PHIT:		DUR 5ms	RISE 0.2ms	/PH,D5,R2/
IMP:	<i>off</i>	LVL 40.0dB	rel 32.0dBm	/IM,S0,L400/
IMP:		INT 1.0s		/IM,I10/
SFI:	<i>off</i>	LVL 10.0dB	FREQ 2600Hz	/SF,S0,L100,F2600/

A→B IMPAIRMENTS (Submenu)

CUSTOM LINE: GAIN TYPE	<i>flat</i>	^	/GD,W0/
CUSTOM LINE: DELAY TYPE	<i>flat</i>	^	/GD,Y0/
NOISE LEVEL CORRECTION:	<i>c-msg</i>	^	/RN,W0/
IMD MODE:	<i>expansive</i>	^	/NL,M0/

B→A IMPAIRMENTS (Main Menu)				Remote Commands
LINE:	<i>flat</i>	NOISE:	<i>off</i> 30.0dBm	/GD,V0/; /RN,S0,L300/
INLVL:	-10.0dBm	OUTLVL:	-30.0dBm	/IO,I-100,L-300/
IMD:	<i>off</i>	2nd 35.0dB	3rd 35.0dB	/NL,S0,Q350,C350/
FREQ SHIFT:	<i>off</i>	0.00Hz		/FS,S0,F0/
AJ:	<i>off</i>	LVL 10.0%	FREQ 60.00Hz	/AJ,S0,L100,F6000/
PJ:	<i>off</i>	LVL 0.0deg	FREQ 60.00Hz	/PJ,S0,L0,F6000/
SATELLITE DELAY:	<i>off</i>		550.000ms	/SD,S0,D4400/
PCM:	<i>off</i>	LINKS 1	CODING <i>mu-law</i>	/PC,S0,L1,C0/
PCM:		RBS <i>off</i>	POSITION <i>last</i>	/PC,R0,P0/
GHIT:	<i>off</i>	LVL 3.0dB	INT 1.0s	/GH,S0,L30,I10/
GHIT:		DUR 5ms	RISE 0.2ms	/GH,D5,R2/
PHIT:	<i>off</i>	LVL 45.0deg	INT 1.0s	/PH,S0,L450,I10/
PHIT:		DUR 5ms	RISE 0.2ms	/PH,D5,R2/
IMP:	<i>off</i>	LVL 40.0dB	rel 32.0dBm	/IM,S0,L400/
IMP:		INT 1.0s		/IM,I10/
SFI:	<i>off</i>	LVL 10.0dB	FREQ 2600Hz	/SF,S0,L100,F2600/

B→A IMPAIRMENTS (Submenu)			
CUSTOM LINE: GAIN TYPE	<i>flat</i>	^	/GD,W0/
CUSTOM LINE: DELAY TYPE	<i>flat</i>	^	/GD,Y0/
NOISE LEVEL CORRECTION:	<i>c-msg</i>	^	/RN,W0/
IMD MODE:	<i>expansive</i>	^	/NL,M0/

CENTRAL OFFICE (Submenu 5)					
A ECHO:	<i>on</i>	NEAR 40.0dB	POL <i>pos</i>	^	/EC,SA1,LA400,PA0/
A ECHO:		FAR 10.0dB	POL <i>pos</i>	^	/EC,LB100,PB0/
B ECHO:	<i>off</i>	NEAR 40.0dB	POL <i>pos</i>	^	/EC,SB0,LC400,PC0/
B ECHO:		FAR 10.0dB	POL <i>pos</i>	^	/EC,LD100,PD0/

A2.2.13. Impairment Parameters for TSB37_L7 [182]:

A→B IMPAIRMENTS (Main Menu)				Remote Commands
LINE:	<i>eia_a1</i>	NOISE:	<i>on</i> 33.4dBm	/GD,V9/;/RN,S1,L334/
INLVL:	<i>-15.6dBm</i>	OUTLVL:	<i>-23.6dBm</i>	/IO,I-156,L-236/
IMD:	<i>on</i>	2nd 42.0dB	3rd 40.0dB	/NL,S1,Q420,C400/
FREQ SHIFT:	<i>off</i>	0.00Hz		/FS,S0,F0/
AJ:	<i>off</i>	LVL 10.0%	FREQ 60.00Hz	/AJ,S0,L100,F6000/
PJ:	<i>on</i>	LVL 10.0deg	FREQ 20.00Hz	/PJ,S1,L100,F2000/
SATELLITE DELAY:	<i>on</i>		14.375ms	/SD,S1,D115/
PCM:	<i>off</i>	LINKS 1	CODING <i>mu-law</i>	/PC,S0,L1,C0/
PCM:		RBS <i>off</i>	POSITION <i>last</i>	/PC,R0,P0/
GHIT:	<i>off</i>	LVL 3.0dB	INT 1.0s	/GH,S0,L30,I10/
GHIT:		DUR 5ms	RISE 0.2ms	/GH,D5,R2/
PHIT:	<i>off</i>	LVL 45.0deg	INT 1.0s	/PH,S0,L450,I10/
PHIT:		DUR 5ms	RISE 0.2ms	/PH,D5,R2/
IMP:	<i>off</i>	LVL 0.0dB	rel 66.4dBm	/IM,S0,L0/
IMP:		INT 0.0s		/IM,I0/
SFI:	<i>off</i>	LVL 10.0dB	FREQ 2600Hz	/SF,S0,L100,F2600/

A→B IMPAIRMENTS (Submenu)			
CUSTOM LINE: GAIN TYPE	<i>flat</i>	^	/GD,W0/
CUSTOM LINE: DELAY TYPE	<i>flat</i>	^	/GD,Y0/
NOISE LEVEL CORRECTION:	<i>3k flat</i>	^	/RN,W1/
IMD MODE:	<i>compressive</i>	^	/NL,M1/

B→A IMPAIRMENTS (Main Menu)				Remote Commands
LINE:	<i>eia_a1</i>	NOISE:	<i>on</i> 38.4dBm	/GD,V9/;/RN,S1,L384/
INLVL:	<i>-10.6dBm</i>	OUTLVL:	<i>-18.6dBm</i>	/IO,I-106,L-186/
IMD:	<i>on</i>	2nd 42.0dB	3rd 40.0dB	/NL,S1,Q420,C400/
FREQ SHIFT:	<i>off</i>	0.00Hz		/FS,S0,F0/
AJ:	<i>off</i>	LVL 10.0%	FREQ 60.00Hz	/AJ,S0,L100,F6000/
PJ:	<i>on</i>	LVL 10.0de	FREQ 21.00Hz	/PJ,S1,L100,F2100/
SATELLITE DELAY:	<i>on</i>		14.375ms	/SD,S1,D115/
PCM:	<i>off</i>	LINKS 1	CODING <i>mu-law</i>	/PC,S0,L1,C0/
PCM:		RBS <i>off</i>	POSITION <i>last</i>	/PC,R0,P0/
GHIT:	<i>off</i>	LVL 3.0dB	INT 1.0s	/GH,S0,L30,I10/
GHIT:		DUR 5ms	RISE 0.2ms	/GH,D5,R2/
PHIT:	<i>off</i>	LVL 45.0deg	INT 1.0s	/PH,S0,L450,I10/
PHIT:		DUR 5ms	RISE 0.2ms	/PH,D5,R2/
IMP:	<i>off</i>	LVL 0.0dB	rel 71.4dBm	/IM,S0,L0/
IMP:		INT 0.0s		/IM,I0/
SFI:	<i>off</i>	LVL 10.0dB	FREQ 2600Hz	/SF,S0,L100,F2600/

B→A IMPAIRMENTS (Submenu)

CUSTOM LINE: GAIN TYPE	<i>flat</i>	^	/GD,W0/
CUSTOM LINE: DELAY TYPE	<i>flat</i>	^	/GD,Y0/
NOISE LEVEL CORRECTION:	<i>3k flat</i>	^	/RN,W1/
IMD MODE:	<i>compressive</i>	^	/NL,M1/

CENTRAL OFFICE (Submenu 5)

A ECHO:	<i>on</i>	NEAR <i>40.0dB</i>	POL <i>neg</i>	^	/EC,SA1,LA400,PA1/
A ECHO:		FAR <i>14.0dB</i>	POL <i>neg</i>	^	/EC,LB140,PB1/
B ECHO:	<i>on</i>	NEAR <i>40.0dB</i>	POL <i>neg</i>	^	/EC,SB1,LC400,PC1/
B ECHO:		FAR <i>14.0dB</i>	POL <i>neg</i>	^	/EC,LD140,PD1/

A2.2.14. Impairment Parameters for TSB37_L8 [182]:

A→B IMPAIRMENTS (Main Menu)

Remote Commands

LINE:	<i>eia_b2</i>	NOISE:	<i>on</i>	<i>38.4dBm</i>	/GD,V10/; /RN,S1,L384/
INLVL:	<i>-15.6dBm</i>	OUTLVL:		<i>-18.6dBm</i>	/IO,I-156,L-186/
IMD:	<i>on</i>	2nd <i>42.0dB</i>		<i>3rd 40.0dB</i>	/NL,S1,Q420,C400/
FREQ SHIFT:	<i>off</i>	<i>0.00Hz</i>			/FS,S0,F0/
AJ:	<i>off</i>	LVL <i>10.0%</i>		FREQ <i>60.00Hz</i>	/AJ,S0,L100,F6000/
PJ:	<i>on</i>	LVL <i>4.0deg</i>		FREQ <i>60.00Hz</i>	/PJ,S1,L40,F6000/
SATELLITE DELAY:		<i>on</i>		<i>15.375ms</i>	/SD,S1,D123/
PCM:	<i>off</i>	LINKS <i>1</i>		CODING <i>mu-law</i>	/PC,S0,L1,C0/
PCM:		RBS <i>off</i>		POSITION <i>last</i>	/PC,R0,P0/
GHIT:	<i>off</i>	LVL <i>3.0dB</i>		INT <i>1.0s</i>	/GH,S0,L30,I10/
GHIT:		DUR <i>5ms</i>		RISE <i>0.2ms</i>	/GH,D5,R2/
PHIT:	<i>off</i>	LVL <i>45.0deg</i>		INT <i>1.0s</i>	/PH,S0,L450,I10/
PHIT:		DUR <i>5ms</i>		RISE <i>0.2ms</i>	/PH,D5,R2/
IMP:	<i>off</i>	LVL <i>0.0dB</i>		rel <i>71.4dBm</i>	/IM,S0,L0/
IMP:		INT <i>0.0s</i>			/IM,I0/
SFI:	<i>off</i>	LVL <i>10.0dB</i>		FREQ <i>2600Hz</i>	/SF,S0,L100,F2600/

A→B IMPAIRMENTS (Submenu)

CUSTOM LINE: GAIN TYPE	<i>flat</i>	^	/GD,W0/
CUSTOM LINE: DELAY TYPE	<i>flat</i>	^	/GD,Y0/
NOISE LEVEL CORRECTION:	<i>3k flat</i>	^	/RN,W1/
IMD MODE:	<i>compressive</i>	^	/NL,M1/

B→A IMPAIRMENTS (Main Menu)				Remote Commands	
LINE:	<i>eia_b2</i>	NOISE:	<i>on</i>	38.4dBm	/GD,V10/; /RN,S1,L384/
INLVL:	<i>-15.6dBm</i>	OUTLVL:		<i>-18.6dBm</i>	/IO,I-156,L-186/
IMD:	<i>on</i>	2nd	<i>42.0dB</i>	3rd <i>40.0dB</i>	/NL,S1,Q420,C400/
FREQ SHIFT:	<i>off</i>		<i>0.00Hz</i>		/FS,S0,F0/
AJ:	<i>off</i>	LVL	<i>10.0%</i>	FREQ <i>60.00Hz</i>	/AJ,S0,L100,F6000/
PJ:	<i>on</i>	LVL	<i>4.0deg</i>	FREQ <i>61.00Hz</i>	/PJ,S1,L40,F6100/
SATELLITE DELAY:		<i>on</i>		<i>15.375ms</i>	/SD,S1,D123/
PCM:	<i>off</i>	LINKS	<i>1</i>	CODING <i>mu-law</i>	/PC,S0,L1,C0/
PCM:		RBS	<i>off</i>	POSITION <i>last</i>	/PC,R0,P0/
GHIT:	<i>off</i>	LVL	<i>3.0dB</i>	INT <i>1.0s</i>	/GH,S0,L30,I10/
GHIT:		DUR	<i>5ms</i>	RISE <i>0.2ms</i>	/GH,D5,R2/
PHIT:	<i>off</i>	LVL	<i>45.0deg</i>	INT <i>1.0s</i>	/PH,S0,L450,I10/
PHIT:		DUR	<i>5ms</i>	RISE <i>0.2ms</i>	/PH,D5,R2/
IMP:	<i>off</i>	LVL	<i>0.0dB</i>	rel <i>71.4dBm</i>	/IM,S0,L0/
IMP:		INT	<i>0.0s</i>		/IM,I0/
SFI:	<i>off</i>	LVL	<i>10.0dB</i>	FREQ <i>2600Hz</i>	/SF,S0,L100,F2600/

B→A IMPAIRMENTS (Submenu)

CUSTOM LINE: GAIN TYPE	<i>flat</i>	^	/GD,W0/
CUSTOM LINE: DELAY TYPE	<i>flat</i>	^	/GD,Y0/
NOISE LEVEL CORRECTION:	<i>3k flat</i>	^	/RN,W1/
IMD MODE:	<i>compressive</i>	^	/NL,M1/

CENTRAL OFFICE (Submenu 5)

A ECHO:	<i>on</i>	NEAR <i>40.0dB</i>	POL <i>neg</i>	^	/EC,SA1,LA400,PA1/
A ECHO:		FAR <i>17.0dB</i>	POL <i>neg</i>	^	/EC,LB170,PB1/
B ECHO:	<i>on</i>	NEAR <i>40.0dB</i>	POL <i>neg</i>	^	/EC,SB1,LC400,PC1/
B ECHO:		FAR <i>17.0dB</i>	POL <i>neg</i>	^	/EC,LD170,PD1/

A2.2.15. Impairment Parameters for TSB37_L9 [182]:

A→B IMPAIRMENTS (Main Menu)				Remote Commands	
LINE:	<i>eia_b2</i>	NOISE:	<i>on</i> 26.4dBm	/GD,V10/; /RN,S1,L264/	
INLVL:	<i>-15.6dBm</i>	OUTLVL:	<i>-30.6dBm</i>	/IO,I-156,L-306/	
IMD:	<i>on</i>	2nd	<i>45.0dB</i>	3rd <i>43.0dB</i>	/NL,S1,Q450,C430/
FREQ SHIFT:	<i>on</i>		<i>-1.00Hz</i>	/FS,S1,F-100/	
AJ:	<i>off</i>	LVL	<i>10.0%</i>	FREQ <i>60.00Hz</i>	/AJ,S0,L100,F6000/
PJ:	<i>on</i>	LVL	<i>4.0deg</i>	FREQ <i>120.00Hz</i>	/PJ,S1,L40,F12000/
SATELLITE DELAY:	<i>on</i>			<i>340.375ms</i>	/SD,S1,D2723/
PCM:	<i>off</i>	LINKS	<i>1</i>	CODING <i>mu-law</i>	/PC,S0,L1,C0/
PCM:		RBS	<i>off</i>	POSITION <i>last</i>	/PC,R0,P0/
GHIT:	<i>off</i>	LVL	<i>3.0dB</i>	INT <i>1.0s</i>	/GH,S0,L30,I10/
GHIT:		DUR	<i>5ms</i>	RISE <i>0.2ms</i>	/GH,D5,R2/
PHIT:	<i>off</i>	LVL	<i>45.0deg</i>	INT <i>1.0s</i>	/PH,S0,L450,I10/
PHIT:		DUR	<i>5ms</i>	RISE <i>0.2ms</i>	/PH,D5,R2/
IMP:	<i>off</i>	LVL	<i>0.0dB</i>	rel <i>59.4dBm</i>	/IM,S0,L0/
IMP:		INT	<i>0.0s</i>		/IM,I0/
SFI:	<i>off</i>	LVL	<i>10.0dB</i>	FREQ <i>2600Hz</i>	/SF,S0,L100,F2600/

A→B IMPAIRMENTS (Submenu)				
CUSTOM LINE: GAIN TYPE	<i>flat</i>		^	/GD,W0/
CUSTOM LINE: DELAY TYPE	<i>flat</i>		^	/GD,Y0/
NOISE LEVEL CORRECTION:	<i>3k flat</i>		^	/RN,W1/
IMD MODE:	<i>compressive</i>		^	/NL,M1/

B→A IMPAIRMENTS (Main Menu)				Remote Commands	
LINE:	<i>eia_b2</i>	NOISE:	<i>on</i> 29.3dBm	/GD,V10/; /RN,S1,L293/	
INLVL:	<i>-12.7dBm</i>	OUTLVL:	<i>-27.7dBm</i>	/IO,I-127,L-27.7/	
IMD:	<i>on</i>	2nd	<i>45.0dB</i>	3rd <i>43.0dB</i>	/NL,S1,Q450,C430/
FREQ SHIFT:	<i>on</i>		<i>0.50Hz</i>	/FS,S1,F50/	
AJ:	<i>off</i>	LVL	<i>10.0%</i>	FREQ <i>60.00Hz</i>	/AJ,S0,L100,F6000/
PJ:	<i>on</i>	LVL	<i>4.0deg</i>	FREQ <i>121.00Hz</i>	/PJ,S1,L40,F1210/
SATELLITE DELAY:	<i>on</i>			<i>340.375ms</i>	/SD,S1,D2723/
PCM:	<i>off</i>	RBS:	<i>off</i>	CODING: <i>mu-law</i>	/PC,S0,C0,R0/
PCM:	<i>off</i>	LINKS	<i>1</i>	CODING <i>mu-law</i>	/PC,S0,L1,C0/
PCM:		RBS	<i>off</i>	POSITION <i>last</i>	/PC,R0,P0/
GHIT:	<i>off</i>	LVL	<i>3.0dB</i>	INT <i>1.0s</i>	/GH,S0,L30,I10/
GHIT:		DUR	<i>5ms</i>	RISE <i>0.2ms</i>	/GH,D5,R2/
PHIT:	<i>off</i>	LVL	<i>45.0deg</i>	INT <i>1.0s</i>	/PH,S0,L450,I10/
PHIT:		DUR	<i>5ms</i>	RISE <i>0.2ms</i>	/PH,D5,R2/
IMP:	<i>off</i>	LVL	<i>0.0dB</i>	rel <i>62.3dBm</i>	/IM,S0,L0/
IMP:		INT	<i>0.0s</i>		/IM,I0/
SFI:	<i>off</i>	LVL	<i>10.0d</i>	FREQ <i>2600Hz</i>	/SF,S0,L100,F2600/

B→A IMPAIRMENTS (Submenu)

CUSTOM LINE: GAIN TYPE	<i>flat</i>	^	/GD,W0/
CUSTOM LINE: DELAY TYPE	<i>flat</i>	^	/GD,Y0/
NOISE LEVEL CORRECTION:	<i>3k flat</i>	^	/RN,W1/
IMD MODE:	<i>compressive</i>	^	/NL,M1/

CENTRAL OFFICE (Submenu 5)

A ECHO:	<i>on</i>	NEAR 40.0dB	POL <i>neg</i>	^	/EC,SA1,LA400,PA1/
A ECHO:		FAR 7.0dB	POL <i>neg</i>	^	/EC,LB70,PB1/
B ECHO:	<i>on</i>	NEAR 40.0dB	POL <i>neg</i>	^	/EC,SB1,LC400,PC1/
B ECHO:		FAR 7.0dB	POL <i>neg</i>	^	/EC,LD70,PD1/

A2.2.16. Impairment Parameters for TSB37_L10 [182]:**A→B IMPAIRMENTS (Main Menu)****Remote Commands**

LINE:	<i>eia_a1</i>	NOISE: <i>on</i>	35.4dBm	/GD,V9/; /RN,S1,L354/
INLVL:	<i>-15.6dBm</i>	OUTLVL:	<i>-21.6dBm</i>	/IO,I-156,L-216/
IMD:	<i>on</i>	2nd 53.0dB	3rd 53.0dB	/NL,S1,Q530,C530/
FREQ SHIFT:	<i>on</i>	1.00Hz		/FS,S1,F100/
AJ:	<i>off</i>	LVL 10.0%	FREQ 60.00Hz	/AJ,S0,L100,F6000/
PJ:	<i>on</i>	LVL 7.0deg	FREQ 60.00Hz	/PJ,S1,L70,F6000/
SATELLITE DELAY:	<i>on</i>		39.375ms	/SD,S1,D315/
PCM:	<i>off</i>	LINKS 1	CODING <i>mu-law</i>	/PC,S0,L1,C0/
PCM:		RBS <i>off</i>	POSITION <i>last</i>	/PC,R0,P0/
GHIT:	<i>off</i>	LVL 3.0dB	INT 1.0s	/GH,S0,L30,I10/
GHIT:		DUR 5ms	RISE 0.2ms	/GH,D5,R2/
PHIT:	<i>off</i>	LVL 45.0deg	INT 1.0s	/PH,S0,L450,I10/
PHIT:		DUR 5ms	RISE 0.2ms	/PH,D5,R2/
IMP:	<i>off</i>	LVL 0.0dB	rel 68.4dBm	/IM,S0,L0/
IMP:		INT 0.0s		/IM,I0/
SFI:	<i>off</i>	LVL 10.0dB	FREQ 2600Hz	/SF,S0,L100,F2600/

A→B IMPAIRMENTS (Submenu)

CUSTOM LINE: GAIN TYPE	<i>flat</i>	^	/GD,W0/
CUSTOM LINE: DELAY TYPE	<i>flat</i>	^	/GD,Y0/
NOISE LEVEL CORRECTION:	<i>3k flat</i>	^	/RN,W1/
IMD MODE:	<i>compressive</i>	^	/NL,M1/

B→A IMPAIRMENTS (Main Menu)				Remote Commands
LINE:	<i>eia_a1</i>	NOISE:	<i>on</i>	40.4dBm /GD,V9/; /RN,S1,L404/
INLVL:	<i>-10.6dBm</i>	OUTLVL:	<i>-16.6dBm</i>	/IO,I-106,L-166/
IMD:	<i>on</i>	2nd	<i>53.0dB</i>	3rd <i>53.0dB</i> /NL,S1,Q530,C530/
FREQ SHIFT:	<i>on</i>		<i>-1.00Hz</i>	/FS,S1,F-100/
AJ:	<i>off</i>	LVL	<i>10.0%</i>	FREQ <i>60.00Hz</i> /AJ,S0,L100,F6000/
PJ:	<i>on</i>	LVL	<i>7.0de</i>	FREQ <i>61.00Hz</i> /PJ,S1,L70,F6100/
SATELLITE DELAY:	<i>on</i>			<i>39.375ms</i> /SD,S1,D315/
PCM:	<i>off</i>	LINKS	<i>1</i>	CODING <i>mu-law</i> /PC,S0,L1,C0/
PCM:		RBS	<i>off</i>	POSITION <i>last</i> /PC,R0,P0/
GHIT:	<i>off</i>	LVL	<i>3.0dB</i>	INT <i>1.0s</i> /GH,S0,L30,I10/
GHIT:		DUR	<i>5ms</i>	RISE <i>0.2ms</i> /GH,D5,R2/
PHIT:	<i>off</i>	LVL	<i>45.0deg</i>	INT <i>1.0s</i> /PH,S0,L450,I10/
PHIT:		DUR	<i>5ms</i>	RISE <i>0.2ms</i> /PH,D5,R2/
IMP:	<i>off</i>	LVL	<i>0.0dB</i>	rel <i>73.4dBm</i> /IM,S0,L0/
IMP:		INT	<i>0.0s</i>	/IM,I0/
SFI:	<i>off</i>	LVL	<i>10.0dB</i>	FREQ <i>2600Hz</i> /SF,S0,L100,F2600/

B→A IMPAIRMENTS (Submenu)			
CUSTOM LINE: GAIN TYPE	<i>flat</i>	^	/GD,W0/
CUSTOM LINE: DELAY TYPE	<i>flat</i>	^	/GD,Y0/
NOISE LEVEL CORRECTION:	<i>3k flat</i>	^	/RN,W1/
IMD MODE:	<i>compressive</i>	^	/NL,M1/

CENTRAL OFFICE (Submenu 5)				
A ECHO:	<i>on</i>	NEAR	<i>40.0dB</i>	POL <i>neg</i> ^ /EC,SA1,LA400,PA1/
A ECHO:		FAR	<i>10.0dB</i>	POL <i>neg</i> ^ /EC,LB100,PB1/
B ECHO:	<i>on</i>	NEAR	<i>40.0dB</i>	POL <i>neg</i> ^ /EC,SB1,LC400,PC1/
B ECHO:		FAR	<i>5.0dB</i>	POL <i>neg</i> ^ /EC,LD50,PD1/

A2.2.17. Impairment Parameters for TSB37_L11 [182]:

A→B IMPAIRMENTS (Main Menu)				Remote Commands
LINE:	<i>eia_a1</i>	NOISE:	<i>on</i>	35.4dBm /GD,V9/; /RN,S1,L354/
INLVL:	<i>-15.6dBm</i>	OUTLVL:	<i>-21.6dBm</i>	/IO,I-156,L-216/
IMD:	<i>on</i>	2nd	<i>42.0dB</i>	3rd <i>40.0dB</i> /NL,S1,Q420,C400/
FREQ SHIFT:	<i>off</i>		<i>0.00Hz</i>	/FS,S0,F0/
AJ:	<i>off</i>	LVL	<i>10.0%</i>	FREQ <i>60.00Hz</i> /AJ,S0,L100,F6000/
PJ:	<i>off</i>	LVL	<i>0.0deg</i>	FREQ <i>0.00Hz</i> /PJ,S0,L0,F0/
SATELLITE DELAY:	<i>on</i>		<i>59.375ms</i>	/SD,S1,D475/
PCM:	<i>off</i>	LINKS	<i>1</i>	CODING <i>mu-law</i> /PC,S0,L1,C0/
PCM:		RBS	<i>off</i>	POSITION <i>last</i> /PC,R0,P0/
GHIT:	<i>off</i>	LVL	<i>3.0dB</i>	INT <i>1.0s</i> /GH,S0,L30,I10/
GHIT:		DUR	<i>5ms</i>	RISE <i>0.2ms</i> /GH,D5,R2/
PHIT:	<i>off</i>	LVL	<i>45.0deg</i>	INT <i>1.0s</i> /PH,S0,L450,I10/
PHIT:		DUR	<i>5ms</i>	RISE <i>0.2ms</i> /PH,D5,R2/
IMP:	<i>off</i>	LVL	<i>0.0dB</i>	rel <i>68.4dBm</i> /IM,S0,L0/
IMP:		INT	<i>0.0s</i>	/IM,I0/
SFI:	<i>off</i>	LVL	<i>10.0dB</i>	FREQ <i>2600Hz</i> /SF,S0,L100,F2600/

A→B IMPAIRMENTS (Submenu)			
CUSTOM LINE: GAIN TYPE	<i>flat</i>	^	/GD,W0/
CUSTOM LINE: DELAY TYPE	<i>flat</i>	^	/GD,Y0/
NOISE LEVEL CORRECTION:	<i>3k flat</i>	^	/RN,W1/
IMD MODE:	<i>compressive</i>	^	/NL,M1/

B→A IMPAIRMENTS (Main Menu)				Remote Commands
LINE:	<i>eia_a1</i>	NOISE:	<i>on</i>	37.7dBm /GD,V9/; /RN,S1,L377/
INLVL:	<i>-13.3dBm</i>	OUTLVL:	<i>-19.3dBm</i>	/IO,I-133,L-193/
IMD:	<i>on</i>	2nd	<i>42.0dB</i>	3rd <i>40.0dB</i> /NL,S1,Q420,C400/ --
FREQ SHIFT:	<i>off</i>		<i>0.00Hz</i>	/FS,S0,F0/
AJ:	<i>off</i>	LVL	<i>10.0%</i>	FREQ <i>60.00Hz</i> /AJ,S0,L100,F6000/
PJ:	<i>off</i>	LVL	<i>0.0de</i>	FREQ <i>0.00Hz</i> /PJ,S0,L0,F0/
SATELLITE DELAY:	<i>on</i>		<i>59.375ms</i>	/SD,S1,D475/
PCM:	<i>off</i>	LINKS	<i>1</i>	CODING <i>mu-law</i> /PC,S0,L1,C0/
PCM:		RBS	<i>off</i>	POSITION <i>last</i> /PC,R0,P0/
GHIT:	<i>off</i>	LVL	<i>3.0dB</i>	INT <i>1.0s</i> /GH,S0,L30,I10/
GHIT:		DUR	<i>5ms</i>	RISE <i>0.2ms</i> /GH,D5,R2/
PHIT:	<i>off</i>	LVL	<i>45.0deg</i>	INT <i>1.0s</i> /PH,S0,L450,I10/
PHIT:		DUR	<i>5ms</i>	RISE <i>0.2ms</i> /PH,D5,R2/
IMP:	<i>off</i>	LVL	<i>0.0dB</i>	rel <i>70.7dBm</i> /IM,S0,L0/
IMP:		INT	<i>0.0s</i>	/IM,I0/
SFI:	<i>off</i>	LVL	<i>10.0dB</i>	FREQ <i>2600Hz</i> /SF,S0,L100,F2600/

B→A IMPAIRMENTS (Submenu)

CUSTOM LINE: GAIN TYPE	<i>flat</i>	^	/GD,W0/
CUSTOM LINE: DELAY TYPE	<i>flat</i>	^	/GD,Y0/
NOISE LEVEL CORRECTION:	<i>3k flat</i>	^	/RN,W1/
IMD MODE:	<i>compressive</i>	^	/NL,M1/

CENTRAL OFFICE (Submenu 5)

A ECHO:	<i>on</i>	NEAR <i>40.0dB</i>	POL <i>neg</i>	^	/EC,SA1,LA400,PA1/
A ECHO:		FAR <i>14.0dB</i>	POL <i>neg</i>	^	/EC,LB140,PB1/
B ECHO:	<i>on</i>	NEAR <i>40.0dB</i>	POL <i>neg</i>	^	/EC,SB1,LC400,PC1/
B ECHO:		FAR <i>5.0dB</i>	POL <i>neg</i>	^	/EC,LD50,PD1/

A2.2.18. Impairment Parameters for TSB37_L12 [182]:

A→B IMPAIRMENTS (Main Menu)

Remote Commands

LINE:	<i>eia_b4</i>	NOISE:	<i>on</i>	<i>38.4dBm</i>	/GD,V12;/RN,S1,L384/
INLVL:	<i>-15.6dBm</i>	OUTLVL:		<i>-18.6dBm</i>	/IO,I-156,L-186/
IMD:	<i>on</i>	2nd	<i>47.0dB</i>	3rd <i>45.0dB</i>	/NL,S1,Q470,C450/
FREQ SHIFT:	<i>on</i>		<i>2.00Hz</i>		/FS,S1,F200/
AJ:	<i>off</i>	LVL	<i>10.0%</i>	FREQ <i>60.00Hz</i>	/AJ,S0,L100,F6000/
PJ:	<i>on</i>	LVL	<i>4.0deg</i>	FREQ <i>60.00Hz</i>	/PJ,S1,L40,F6000/
SATELLITE DELAY:	<i>on</i>			<i>16.625ms</i>	/SD,S1,D133/
PCM:	<i>off</i>	LINKS	<i>1</i>	CODING <i>mu-law</i>	/PC,S0,L1,C0/
PCM:		RBS	<i>off</i>	POSITION <i>last</i>	/PC,R0,P0/
GHIT:	<i>off</i>	LVL	<i>3.0dB</i>	INT <i>1.0s</i>	/GH,S0,L30,I10/
GHIT:		DUR	<i>5ms</i>	RISE <i>0.2ms</i>	/GH,D5,R2/
PHIT:	<i>off</i>	LVL	<i>45.0deg</i>	INT <i>1.0s</i>	/PH,S0,L450,I10/
PHIT:		DUR	<i>5ms</i>	RISE <i>0.2ms</i>	/PH,D5,R2/
IMP:	<i>off</i>	LVL	<i>0.0dB</i>	rel <i>71.4dBm</i>	/IM,S0,L0/
IMP:		INT	<i>0.0s</i>		/IM,I0/
SFI:	<i>off</i>	LVL	<i>10.0dB</i>	FREQ <i>2600Hz</i>	/SF,S0,L100,F2600/

A→B IMPAIRMENTS (Submenu)

CUSTOM LINE: GAIN TYPE	<i>flat</i>	^	/GD,W0/
CUSTOM LINE: DELAY TYPE	<i>flat</i>	^	/GD,Y0/
NOISE LEVEL CORRECTION:	<i>3k flat</i>	^	/RN,W1/
IMD MODE:	<i>compressive</i>	^	/NL,M1/

B→A IMPAIRMENTS (Main Menu)				Remote Commands		
LINE:	<i>eia_b4</i>	NOISE:	<i>on</i>	37.5dBm	/GD,V12;/RN,S1,L375/	
INLVL:	<i>-16.5dBm</i>	OUTLVL:		<i>-19.5dBm</i>	/IO,I-165,L-195/	
IMD:	<i>on</i>	2nd	<i>47.0dB</i>	3rd	<i>45.0dB</i>	/NL,S1,Q470,C450/
FREQ SHIFT:	<i>on</i>		<i>-1.00Hz</i>			/FS,S1,F-100/
AJ:	<i>off</i>	LVL	<i>10.0%</i>	FREQ	<i>60.00Hz</i>	/AJ,S0,L100,F6000/
PJ:	<i>on</i>	LVL	<i>4.0deg</i>	FREQ	<i>61.00Hz</i>	/PJ,S1,L40,F6100/
SATELLITE DELAY:		<i>on</i>			<i>16.625ms</i>	/SD,S1,D133/
PCM:	<i>off</i>	LINKS	<i>1</i>	CODING	<i>mu-law</i>	/PC,S0,L1,C0/
PCM:		RBS	<i>off</i>	POSITION	<i>last</i>	/PC,R0,P0/
GHIT:	<i>off</i>	LVL	<i>3.0dB</i>	INT	<i>1.0s</i>	/GH,S0,L30,I10/
GHIT:		DUR	<i>5ms</i>	RISE	<i>0.2ms</i>	/GH,D5,R2/
PHIT:	<i>off</i>	LVL	<i>45.0deg</i>	INT	<i>1.0s</i>	/PH,S0,L450,I10/
PHIT:		DUR	<i>5ms</i>	RISE	<i>0.2ms</i>	/PH,D5,R2/
IMP:	<i>off</i>	LVL	<i>0.0dB</i>	rel	<i>70.5dBm</i>	/IM,S0,L0/
IMP:		INT	<i>0.0s</i>			/IM,I0/
SFI:	<i>off</i>	LVL	<i>10.0dB</i>	FREQ	<i>2600Hz</i>	/SF,S0,L100,F2600/

B→A IMPAIRMENTS (Submenu)

CUSTOM LINE: GAIN TYPE	<i>flat</i>	^	/GD,W0/
CUSTOM LINE: DELAY TYPE	<i>flat</i>	^	/GD,Y0/
NOISE LEVEL CORRECTION:	<i>3k flat</i>	^	/RN,W1/
IMD MODE:	<i>compressive</i>	^	/NL,M1/

CENTRAL OFFICE (Submenu 5)

A ECHO:	<i>on</i>	NEAR	<i>40.0dB</i>	POL	<i>neg</i>	^	/EC,SA1,LA400,PA1/
A ECHO:		FAR	<i>18.0dB</i>	POL	<i>neg</i>	^	/EC,LB180,PB1/
B ECHO:	<i>on</i>	NEAR	<i>40.0dB</i>	POL	<i>neg</i>	^	/EC,SB1,LC400,PC1/
B ECHO:		FAR	<i>7.0dB</i>	POL	<i>neg</i>	^	/EC,LD70,PD1/

A2.2.19. Impairment Parameters for TSB37_L13 [182]:

A→B IMPAIRMENTS (Main Menu)				Remote Commands
LINE:	<i>eia_b3</i>	NOISE:	<i>on</i>	38.4dBm /GD,V111;/RN,S1,L384/
INLVL:	<i>-15.6dBm</i>	OUTLVL:	<i>-18.6dBm</i>	/IO,I-156,L-186/
IMD:	<i>on</i>	2nd	<i>53.0dB</i>	3rd <i>53.0dB</i> /NL,S1,Q530,C530/
FREQ SHIFT:	<i>off</i>		<i>0.00Hz</i>	/FS,S0,F0/
AJ:	<i>off</i>	LVL	<i>10.0%</i>	FREQ <i>60.00Hz</i> /AJ,S0,L100,F6000/
PJ:	<i>on</i>	LVL	<i>4.0deg</i>	FREQ <i>60.00Hz</i> /PJ,S1,L40,F6000/
SATELLITE DELAY:	<i>on</i>		<i>40.625ms</i>	/SD,S1,D325/
PCM:	<i>off</i>	LINKS	<i>1</i>	CODING <i>mu-law</i> /PC,S0,L1,C0/
PCM:		RBS	<i>off</i>	POSITION <i>last</i> /PC,R0,P0/
GHIT:	<i>off</i>	LVL	<i>3.0dB</i>	INT <i>1.0s</i> /GH,S0,L30,I10/
GHIT:		DUR	<i>5ms</i>	RISE <i>0.2ms</i> /GH,D5,R2/
PHIT:	<i>off</i>	LVL	<i>45.0deg</i>	INT <i>1.0s</i> /PH,S0,L450,I10/
PHIT:		DUR	<i>5ms</i>	RISE <i>0.2ms</i> /PH,D5,R2/
IMP:	<i>off</i>	LVL	<i>0.0dB</i>	rel <i>71.4dBm</i> /IM,S0,L0/
IMP:		INT	<i>0.0s</i>	/IM,I0/
SFI:	<i>off</i>	LVL	<i>10.0dB</i>	FREQ <i>2600Hz</i> /SF,S0,L100,F2600/

A→B IMPAIRMENTS (Submenu)				
CUSTOM LINE: GAIN TYPE	<i>flat</i>		^	/GD,W0/
CUSTOM LINE: DELAY TYPE	<i>flat</i>		^	/GD,Y0/
NOISE LEVEL CORRECTION:	<i>3k flat</i>		^	/RN,W1/
IMD MODE:	<i>compressive</i>		^	/NL,M1/

B→A IMPAIRMENTS (Main Menu)				Remote Commands
LINE:	<i>eia_b3</i>	NOISE:	<i>on</i>	37.5dBm /GD,V111;/RN,S1,L375/
INLVL:	<i>-16.5dBm</i>	OUTLVL:	<i>-19.5dBm</i>	/IO,I-165,L-195/
IMD:	<i>on</i>	2nd	<i>53.0dB</i>	3rd <i>53.0dB</i> /NL,S1,Q530,C530/
FREQ SHIFT:	<i>off</i>		<i>0.00Hz</i>	/FS,S0,F0/
AJ:	<i>off</i>	LVL	<i>10.0%</i>	FREQ <i>60.00Hz</i> /AJ,S0,L100,F6000/
PJ:	<i>on</i>	LVL	<i>4.0de</i>	FREQ <i>61.00Hz</i> /PJ,S1,L40,F6100/
SATELLITE DELAY:	<i>on</i>		<i>40.625ms</i>	/SD,S1,D325/
PCM:	<i>off</i>	LINKS	<i>1</i>	CODING <i>mu-law</i> /PC,S0,L1,C0/
PCM:		RBS	<i>off</i>	POSITION <i>last</i> /PC,R0,P0/
GHIT:	<i>off</i>	LVL	<i>3.0dB</i>	INT <i>1.0s</i> /GH,S0,L30,I10/
GHIT:		DUR	<i>5ms</i>	RISE <i>0.2ms</i> /GH,D5,R2/
PHIT:	<i>off</i>	LVL	<i>45.0deg</i>	INT <i>1.0s</i> /PH,S0,L450,I10/
PHIT:		DUR	<i>5ms</i>	RISE <i>0.2ms</i> /PH,D5,R2/
IMP:	<i>off</i>	LVL	<i>0.0dB</i>	rel <i>70.5dBm</i> /IM,S0,L0/
IMP:		INT	<i>0.0s</i>	/IM,I0/
SFI:	<i>off</i>	LVL	<i>10.0dB</i>	FREQ <i>2600Hz</i> /SF,S0,L100,F2600/

B→A IMPAIRMENTS (Submenu)

CUSTOM LINE: GAIN TYPE	<i>flat</i>	^	/GD,W0/
CUSTOM LINE: DELAY TYPE	<i>flat</i>	^	/GD,Y0/
NOISE LEVEL CORRECTION:	<i>3k flat</i>	^	/RN,W1/
IMD MODE:	<i>compressive</i>	^	/NL,M1/

CENTRAL OFFICE (Submenu 5)

A ECHO:	<i>on</i>	NEAR <i>40.0dB</i>	POL <i>neg</i>	^	/EC,SA1,LA400,PA1/
A ECHO:		FAR <i>18.0dB</i>	POL <i>neg</i>	^	/EC,LB180,PB1/
B ECHO:	<i>on</i>	NEAR <i>40.0dB</i>	POL <i>neg</i>	^	/EC,SB1,LC400,PC1/
B ECHO:		FAR <i>7.0dB</i>	POL <i>neg</i>	^	/EC,LD70,PD1/

A2.2.20. Impairment Parameters for TSB37_L14 [182]:**A→B IMPAIRMENTS (Main Menu)****Remote Commands**

LINE:	<i>eia_b2</i>	NOISE:	<i>on</i>	<i>38.4dBm</i>	/GD,V10/; /RN,S1,L384/
INLVL:	<i>-15.6dBm</i>	OUTLVL:		<i>-18.6dBm</i>	/IO,I-156,L-186/
IMD:	<i>on</i>	2nd	<i>42.0dB</i>	3rd <i>40.0dB</i>	/NL,S1,Q420,C400/
FREQ SHIFT:	<i>off</i>		<i>0.00Hz</i>		/FS,S0,F0/
AJ:	<i>off</i>	LVL	<i>10.0%</i>	FREQ <i>60.00Hz</i>	/AJ,S0,L100,F6000/
PJ:	<i>on</i>	LVL	<i>4.0deg</i>	FREQ <i>60.00Hz</i>	/PJ,S1,L40,F6000/
SATELLITE DELAY:		<i>on</i>		<i>15.375ms</i>	/SD,S1,D123/
PCM:	<i>off</i>	LINKS	<i>1</i>	CODING <i>mu-law</i>	/PC,S0,L1,C0/
PCM:		RBS	<i>off</i>	POSITION <i>last</i>	/PC,R0,P0/
GHIT:	<i>off</i>	LVL	<i>3.0dB</i>	INT <i>1.0s</i>	/GH,S0,L30,I10/
GHIT:		DUR	<i>5ms</i>	RISE <i>0.2ms</i>	/GH,D5,R2/
PHIT:	<i>off</i>	LVL	<i>45.0deg</i>	INT <i>1.0s</i>	/PH,S0,L450,I10/
PHIT:		DUR	<i>5ms</i>	RISE <i>0.2ms</i>	/PH,D5,R2/
IMP:	<i>off</i>	LVL	<i>0.0dB</i>	rel <i>71.4dBm</i>	/IM,S0,L0/
IMP:		INT	<i>0.0s</i>		/IM,I0/
SFI:	<i>off</i>	LVL	<i>10.0dB</i>	FREQ <i>2600Hz</i>	/SF,S0,L100,F2600/

A→B IMPAIRMENTS (Submenu)

CUSTOM LINE: GAIN TYPE	<i>flat</i>	^	/GD,W0/
CUSTOM LINE: DELAY TYPE	<i>flat</i>	^	/GD,Y0/
NOISE LEVEL CORRECTION:	<i>3k flat</i>	^	/RN,W1/
IMD MODE:	<i>compressive</i>	^	/NL,M1/

B→A IMPAIRMENTS (Main Menu)				Remote Commands	
LINE:	<i>eia_b2</i>	NOISE:	<i>on</i>	37.9dBm	/GD,V10/; /RN,S1,L379/
INLVL:	<i>-16.1dBm</i>	OUTLVL:		<i>-19.1dBm</i>	/IO,I-161,L-191/
IMD:	<i>on</i>	2nd	<i>42.0dB</i>	3rd <i>40.0dB</i>	/NL,S1,Q420,C400/
FREQ SHIFT:	<i>off</i>		<i>0.00Hz</i>		/FS,S0,F0/
AJ:	<i>off</i>	LVL	<i>10.0%</i>	FREQ <i>60.00Hz</i>	/AJ,S0,L100,F6000/
PJ:	<i>on</i>	LVL	<i>4.0deg</i>	FREQ <i>61.00Hz</i>	/PJ,S1,L40,F6100/
SATELLITE DELAY:			<i>on</i>	<i>15.375ms</i>	/SD,S1,D123/
PCM:	<i>off</i>	LINKS	<i>1</i>	CODING <i>mu-law</i>	/PC,S0,L1,C0/
PCM:		RBS	<i>off</i>	POSITION <i>last</i>	/PC,R0,P0/
GHIT:	<i>off</i>	LVL	<i>3.0dB</i>	INT <i>1.0s</i>	/GH,S0,L30,I10/
GHIT:		DUR	<i>5ms</i>	RISE <i>0.2ms</i>	/GH,D5,R2/
PHIT:	<i>off</i>	LVL	<i>45.0deg</i>	INT <i>1.0s</i>	/PH,S0,L450,I10/
PHIT:		DUR	<i>5ms</i>	RISE <i>0.2ms</i>	/PH,D5,R2/
IMP:	<i>off</i>	LVL	<i>0.0dB</i>	rel <i>70.9dBm</i>	/TM,S0,L0/
IMP:		INT	<i>0.0s</i>		/TM,I0/
SFI:	<i>off</i>	LVL	<i>10.0dB</i>	FREQ <i>2600Hz</i>	/SF,S0,L100,F2600/

B→A IMPAIRMENTS (Submenu)

CUSTOM LINE: GAIN TYPE	<i>flat</i>	^	/GD,W0/
CUSTOM LINE: DELAY TYPE	<i>flat</i>	^	/GD,Y0/
NOISE LEVEL CORRECTION:	<i>3k flat</i>	^	/RN,W1/
IMD MODE:	<i>compressive</i>	^	/NL,M1/

CENTRAL OFFICE (Submenu 5)

A ECHO:	<i>on</i>	NEAR	<i>40.0dB</i>	POL <i>neg</i>	^	/EC,SA1,LA400,PA1/
A ECHO:		FAR	<i>17.0dB</i>	POL <i>neg</i>	^	/EC,LB170,PB1/
B ECHO:	<i>on</i>	NEAR	<i>40.0dB</i>	POL <i>neg</i>	^	/EC,SB1,LC400,PC1/
B ECHO:		FAR	<i>17.0dB</i>	POL <i>neg</i>	^	/EC,LD170,PD1/

A2.2.21. Impairment Parameters for TSB37_L15 [182]:

A→B IMPAIRMENTS (Main Menu)				Remote Commands
LINE:	<i>eia_a1</i>	NOISE:	<i>on</i>	35.4dBm /GD,V9/; /RN,S1,L354/
INLVL:	<i>-15.6dBm</i>	OUTLVL:	<i>-21.6dBm</i>	/IO,I-156,L-216/
IMD:	<i>on</i>	2nd	<i>42.0dB</i>	3rd <i>40.0dB</i> /NL,S1,Q420,C400/
FREQ SHIFT:	<i>off</i>		<i>0.00Hz</i>	/FS,S0,F0/
AJ:	<i>off</i>	LVL	<i>10.0%</i>	FREQ <i>60.00Hz</i> /AJ,S0,L100,F6000/
PJ:	<i>off</i>	LVL	<i>0.0deg</i>	FREQ <i>0.00Hz</i> /PJ,S0,L0,F0/
SATELLITE DELAY:	<i>on</i>			<i>59.375ms</i> /SD,S1,D475/
PCM:	<i>off</i>	LINKS	<i>1</i>	CODING <i>mu-law</i> /PC,S0,L1,C0/
PCM:		RBS	<i>off</i>	POSITION <i>last</i> /PC,R0,P0/
GHIT:	<i>off</i>	LVL	<i>3.0dB</i>	INT <i>1.0s</i> /GH,S0,L30,I10/
GHIT:		DUR	<i>5ms</i>	RISE <i>0.2ms</i> /GH,D5,R2/
PHIT:	<i>off</i>	LVL	<i>45.0deg</i>	INT <i>1.0s</i> /PH,S0,L450,I10/
PHIT:		DUR	<i>5ms</i>	RISE <i>0.2ms</i> /PH,D5,R2/
IMP:	<i>off</i>	LVL	<i>0.0dB</i>	rel <i>68.4dBm</i> /IM,S0,L0/
IMP:		INT	<i>0.0s</i>	/IM,I0/
SFI:	<i>off</i>	LVL	<i>10.0d</i>	FREQ <i>2600Hz</i> /SF,S0,L100,F2600/

A→B IMPAIRMENTS (Submenu)			
CUSTOM LINE: GAIN TYPE	<i>flat</i>		^ /GD,W0/
CUSTOM LINE: DELAY TYPE	<i>flat</i>		^ /GD,Y0/
NOISE LEVEL CORRECTION:	<i>3k flat</i>		^ /RN,W1/
IMD MODE:	<i>compressive</i>		^ /NL,M1/

B→A IMPAIRMENTS (Main Menu)				Remote Commands
LINE:	<i>eia_a1</i>	NOISE:	<i>on</i>	35.6dBm /GD,V9/; /RN,S1,L356/
INLVL:	<i>-15.4dBm</i>	OUTLVL:	<i>-21.4dBm</i>	/IO,I-154,L-214/
IMD:	<i>on</i>	2nd	<i>42.0dB</i>	3rd <i>40.0dB</i> /NL,S1,Q420,C400/
FREQ SHIFT:	<i>off</i>		<i>0.00Hz</i>	/FS,S0,F0/
AJ:	<i>off</i>	LVL	<i>10.0%</i>	FREQ <i>60.00Hz</i> /AJ,S0,L100,F6000/
PJ:	<i>off</i>	LVL	<i>0.0deg</i>	FREQ <i>0.00Hz</i> /PJ,S0,L0,F0/
SATELLITE DELAY:	<i>on</i>			<i>59.375ms</i> /SD,S1,D475/
PCM:	<i>off</i>	LINKS	<i>1</i>	CODING <i>mu-law</i> /PC,S0,L1,C0/
PCM:		RBS	<i>off</i>	POSITION <i>last</i> /PC,R0,P0/
GHIT:	<i>off</i>	LVL	<i>3.0dB</i>	INT <i>1.0s</i> /GH,S0,L30,I10/
GHIT:		DUR	<i>5ms</i>	RISE <i>0.2ms</i> /GH,D5,R2/
PHIT:	<i>off</i>	LVL	<i>45.0deg</i>	INT <i>1.0s</i> /PH,S0,L450,I10/
PHIT:		DUR	<i>5ms</i>	RISE <i>0.2ms</i> /PH,D5,R2/
IMP:	<i>off</i>	LVL	<i>0.0dB</i>	rel <i>68.6dBm</i> /IM,S0,L0/
IMP:		INT	<i>0.0s</i>	/IM,I0/
SFI:	<i>off</i>	LVL	<i>10.0dB</i>	FREQ <i>2600Hz</i> /SF,S0,L100,F2600/

B→A IMPAIRMENTS (Submenu)

CUSTOM LINE: GAIN TYPE	<i>flat</i>	^	/GD,W0/
CUSTOM LINE: DELAY TYPE	<i>flat</i>	^	/GD,Y0/
NOISE LEVEL CORRECTION:	<i>3k flat</i>	^	/RN,W1/
IMD MODE:	<i>compressive</i>	^	/NL,M1/

CENTRAL OFFICE (Submenu 5)

A ECHO:	<i>on</i>	NEAR <i>40.0dB</i>	POL <i>neg</i>	^	/EC,SA1,LA400,PA1/
A ECHO:		FAR <i>14.0dB</i>	POL <i>neg</i>	^	/EC,LB140,PB1/
B ECHO:	<i>on</i>	NEAR <i>40.0dB</i>	POL <i>neg</i>	^	/EC,SB1,LC400,PC1/
B ECHO:		FAR <i>5.0dB</i>	POL <i>neg</i>	^	/EC,LD50,PD1/

A2.2.22. Impairment Parameters for TSB37_L16 [182]:

A→B IMPAIRMENTS (Main Menu)

Remote Commands

LINE:	<i>eia_a1</i>	NOISE:	<i>on</i>	<i>33.4dBm</i>	/GD,V9/; /RN,S1,L334/
INLVL:	<i>-15.6dBm</i>	OUTLVL:		<i>-23.6dBm</i>	/IO,I-156,L-236/
IMD:	<i>on</i>	2nd	<i>53.0dB</i>	3rd <i>53.0dB</i>	/NL,S1,Q530,C530/
FREQ SHIFT:	<i>off</i>		<i>0.00Hz</i>		/FS,S0,F0/
AJ:	<i>off</i>	LVL	<i>10.0%</i>	FREQ <i>60.00Hz</i>	/AJ,S0,L100,F6000/
PJ:	<i>off</i>	LVL	<i>0.0deg</i>	FREQ <i>0.00Hz</i>	/PJ,S0,L0,F0/
SATELLITE DELAY:	<i>on</i>			<i>14.375ms</i>	/SD,S1,D115/
PCM:	<i>off</i>	LINKS	<i>1</i>	CODING <i>mu-law</i>	/PC,S0,L1,C0/
PCM:		RBS	<i>off</i>	POSITION <i>last</i>	/PC,R0,P0/
GHIT:	<i>off</i>	LVL	<i>3.0dB</i>	INT <i>1.0s</i>	/GH,S0,L30,I10/
GHIT:		DUR	<i>5ms</i>	RISE <i>0.2ms</i>	/GH,D5,R2/
PHIT:	<i>off</i>	LVL	<i>45.0deg</i>	INT <i>1.0s</i>	/PH,S0,L450,I10/
PHIT:		DUR	<i>5ms</i>	RISE <i>0.2ms</i>	/PH,D5,R2/
IMP:	<i>on</i>	LVL	<i>9.4dB</i>	rel <i>57.0dBm</i>	/IM,S1,L94/
IMP:		INT	<i>1.0s</i>		/IM,I10/
SFI:	<i>off</i>	LVL	<i>10.0dB</i>	FREQ <i>2600Hz</i>	/SF,S0,L100,F2600/

A→B IMPAIRMENTS (Submenu)

CUSTOM LINE: GAIN TYPE	<i>flat</i>	^	/GD,W0/
CUSTOM LINE: DELAY TYPE	<i>flat</i>	^	/GD,Y0/
NOISE LEVEL CORRECTION:	<i>3k flat</i>	^	/RN,W1/
IMD MODE:	<i>compressive</i>	^	/NL,M1/

B→A IMPAIRMENTS (Main Menu)				Remote Commands
LINE:	<i>eia_a1</i>	NOISE:	<i>on</i>	36.3dBm /GD,V9/; /RN,S1,L363/
INLVL:	<i>-12.7dBm</i>	OUTLVL:	<i>-20.7dBm</i>	/IO,I-127,L-207/
IMD:	<i>on</i>	2nd	<i>53.0dB</i>	3rd <i>53.0dB</i> /NL,S1,Q530,C530/
FREQ SHIFT:	<i>off</i>		<i>0.00Hz</i>	/FS,S0,F0/
AJ:	<i>off</i>	LVL	<i>10.0%</i>	FREQ <i>60.00Hz</i> /AJ,S0,L100,F6000/
PJ:	<i>off</i>	LVL	<i>0.0deg</i>	FREQ <i>0.00Hz</i> /PJ,S0,L0,F0/
SATELLITE DELAY:	<i>on</i>			<i>14.375ms</i> /SD,S1,D115/
PCM:	<i>off</i>	LINKS	<i>1</i>	CODING <i>mu-law</i> /PC,S0,L1,C0/
PCM:		RBS	<i>off</i>	POSITION <i>last</i> /PC,R0,P0/
GHIT:	<i>off</i>	LVL	<i>3.0dB</i>	INT <i>1.0s</i> /GH,S0,L30,I10/
GHIT:		DUR	<i>5ms</i>	RISE <i>0.2ms</i> /GH,D5,R2/
PHIT:	<i>off</i>	LVL	<i>45.0deg</i>	INT <i>1.0s</i> /PH,S0,L450,I10/
PHIT:		DUR	<i>5ms</i>	RISE <i>0.2ms</i> /PH,D5,R2/
IMP:	<i>off</i>	LVL	<i>0.0dB</i>	rel <i>69.3dBm</i> /IM,S0,L0/
IMP:		INT	<i>0.0s</i>	/IM,I0/
SFI:	<i>off</i>	LVL	<i>10.0dB</i>	FREQ <i>2600Hz</i> /SF,S0,L100,F2600/

B→A IMPAIRMENTS (Submenu)			
CUSTOM LINE: GAIN TYPE	<i>flat</i>		^ /GD,W0/
CUSTOM LINE: DELAY TYPE	<i>flat</i>		^ /GD,Y0/
NOISE LEVEL CORRECTION:	<i>3k flat</i>		^ /RN,W1/
IMD MODE:	<i>compressive</i>		^ /NL,M1/

CENTRAL OFFICE (Submenu 5)					
A ECHO:	<i>on</i>	NEAR	<i>40.0dB</i>	POL <i>neg</i>	^ /EC,SA1,LA400,PA1/
A ECHO:		FAR	<i>18.0dB</i>	POL <i>neg</i>	^ /EC,LB180,PB1/
B ECHO:	<i>on</i>	NEAR	<i>40.0dB</i>	POL <i>neg</i>	^ /EC,SB1,LC400,PC1/
B ECHO:		FAR	<i>14.0dB</i>	POL <i>neg</i>	^ /EC,LD140,PD1/

A2.2.23. Impairment Parameters for EIA_L17a [182]:

A→B IMPAIRMENTS (Main Menu)				Remote Commands
LINE:	<i>flat</i>	NOISE:	<i>on</i> 22.0dBm	/GD,V0/; /RN,S1,L220/
INLVL:	<i>-12.0dBm</i>	OUTLVL:	<i>-18.0dBm</i>	/IO,I-120,L-180/
IMD:	<i>on</i>	2nd	<i>40.0dB</i> 3rd <i>41.0dB</i>	/NL,S1,Q400,C410/
FREQ SHIFT:	<i>off</i>		<i>0.00Hz</i>	/FS,S0,F0/
AJ:	<i>off</i>	LVL	<i>10.0%</i> FREQ <i>60.00Hz</i>	/AJ,S0,L100,F6000/
PJ:	<i>off</i>	LVL	<i>0.0deg</i> FREQ <i>0.00Hz</i>	/PJ,S0,L0,F0/
SATELLITE DELAY:	<i>on</i>		<i>29.000ms</i>	/SD,S1,D232/
PCM:	<i>on</i>	LINKS	<i>1</i> CODING <i>mu-law</i>	/PC,S1,L1,C0/
PCM:		RBS	<i>on</i> POSITION <i>last</i>	/PC,R1,P0/
GHIT:	<i>off</i>	LVL	<i>3.0dB</i> INT <i>1.0s</i>	/GH,S0,L30,I10/
GHIT:		DUR	<i>5ms</i> RISE <i>0.2ms</i>	/GH,D5,R2/
PHIT:	<i>off</i>	LVL	<i>45.0deg</i> INT <i>1.0s</i>	/PH,S0,L450,I10/
PHIT:		DUR	<i>5ms</i> RISE <i>0.2ms</i>	/PH,D5,R2/
IMP:	<i>off</i>	LVL	<i>0.0dB</i> rel <i>72.0dBm</i>	/IM,S0,L0/
IMP:		INT	<i>0.0s</i>	/IM,I0/
SFI:	<i>off</i>	LVL	<i>10.0dB</i> FREQ <i>2600Hz</i>	/SF,S0,L100,F2600/

A→B IMPAIRMENTS (Submenu)			
CUSTOM LINE: GAIN TYPE	<i>flat</i>	^	/GD,W0/
CUSTOM LINE: DELAY TYPE	<i>flat</i>	^	/GD,Y0/
NOISE LEVEL CORRECTION:	<i>3k flat</i>	^	/RN,W1/
IMD MODE:	<i>compressive</i>	^	/NL,M1/

B→A IMPAIRMENTS (Main Menu)				Remote Commands
LINE:	<i>flat</i>	NOISE:	<i>on</i> 22.0dBm	/GD,V0/; /RN,S1,L220/
INLVL:	<i>-12.0dBm</i>	OUTLVL:	<i>-18.0dBm</i>	/IO,I-120,L-180/
IMD:	<i>on</i>	2nd	<i>40.0dB</i> 3rd <i>41.0dB</i>	/NL,S1,Q400,C410/
FREQ SHIFT:	<i>off</i>		<i>0.00Hz</i>	/FS,S0,F0/
AJ:	<i>off</i>	LVL	<i>10.0%</i> FREQ <i>60.00Hz</i>	/AJ,S0,L100,F6000/
PJ:	<i>off</i>	LVL	<i>0.0deg</i> FREQ <i>0.00Hz</i>	/PJ,S0,L0,F0/
SATELLITE DELAY:	<i>on</i>		<i>29.000ms</i>	/SD,S1,D232/
PCM:	<i>on</i>	LINKS	<i>1</i> CODING <i>mu-law</i>	/PC,S1,L1,C0/
PCM:		RBS	<i>on</i> POSITION <i>first</i>	/PC,R1,P1/
GHIT:	<i>off</i>	LVL	<i>3.0dB</i> INT <i>1.0s</i>	/GH,S0,L30,I10/
GHIT:		DUR	<i>5ms</i> RISE <i>0.2ms</i>	/GH,D5,R2/
PHIT:	<i>off</i>	LVL	<i>45.0deg</i> INT <i>1.0s</i>	/PH,S0,L450,I10/
PHIT:		DUR	<i>5ms</i> RISE <i>0.2ms</i>	/PH,D5,R2/
IMP:	<i>off</i>	LVL	<i>0.0dB</i> rel <i>72.0dBm</i>	/IM,S0,L0/
IMP:		INT	<i>0.0s</i>	/IM,I0/
SFI:	<i>off</i>	LVL	<i>10.0dB</i> FREQ <i>2600Hz</i>	/SF,S0,L100,F2600/

B→A IMPAIRMENTS (Submenu)

CUSTOM LINE: GAIN TYPE	<i>flat</i>	^	/GD,W0/
CUSTOM LINE: DELAY TYPE	<i>flat</i>	^	/GD,Y0/
NOISE LEVEL CORRECTION:	<i>3k flat</i>	^	/RN,W1/
IMD MODE:	<i>compressive</i>	^	/NL,M1/

CENTRAL OFFICE (Submenu 5)

A ECHO:	<i>on</i>	NEAR 40.0dB	POL <i>neg</i>	^	/EC,SA1,LA400,PA1/
A ECHO:		FAR 12.0dB	POL <i>neg</i>	^	/EC,LB120,PB1/
B ECHO:	<i>on</i>	NEAR 40.0dB	POL <i>neg</i>	^	/EC,SB1,LC400,PC1/
B ECHO:		FAR 12.0dB	POL <i>neg</i>	^	/EC,LD120,PD1/

A2.2.24. Impairment Parameters for EIA_L17b [182]:

A→B IMPAIRMENTS (Main Menu)**Remote Commands**

LINE:	<i>flat</i>	NOISE:	<i>on</i>	22.0dBm	/GD,V0/; /RN,S1,L220/
INLVL:	<i>-12.0dBm</i>	OUTLVL:		<i>-18.0dBm</i>	/IO,I-120,L-180/
IMD:	<i>on</i>	2nd		<i>43.0dB</i>	/NL,S1,Q430,C544/
		3rd		<i>44.0dB</i>	
FREQ SHIFT:	<i>off</i>			<i>0.00Hz</i>	/FS,S0,F0/
AJ:	<i>off</i>	LVL		<i>10.0%</i>	/AJ,S0,L100,F6000/
PJ:	<i>off</i>	LVL		<i>0.0deg</i>	/PJ,S0,L0,F0/
SATELLITE DELAY:		<i>on</i>		<i>29.000ms</i>	/SD,S1,D232/
PCM:	<i>on</i>	LINKS		<i>1</i>	/PC,S1,L1,C0/
PCM:		RBS		<i>on</i>	/PC,R1,P0/
GHIT:	<i>off</i>	LVL		<i>3.0dB</i>	/GH,S0,L30,I10/
GHIT:		DUR		<i>5ms</i>	/GH,D5,R2/
PHIT:	<i>off</i>	LVL		<i>45.0deg</i>	/PH,S0,L450,I10/
PHIT:		DUR		<i>5ms</i>	/PH,D5,R2/
IMP:	<i>off</i>	LVL		<i>0.0dB</i>	/IM,S0,L0/
IMP:		INT		<i>0.0s</i>	/IM,I0/
SFI:	<i>off</i>	LVL		<i>10.0dB</i>	/SF,S0,L100,F2600/
				<i>FREQ 2600Hz</i>	

A→B IMPAIRMENTS (Submenu)

CUSTOM LINE: GAIN TYPE	<i>flat</i>	^	/GD,W0/
CUSTOM LINE: DELAY TYPE	<i>flat</i>	^	/GD,Y0/
NOISE LEVEL CORRECTION:	<i>3k flat</i>	^	/RN,W1/
IMD MODE:	<i>compressive</i>	^	/NL,M1/

B→A IMPAIRMENTS (Main Menu)				Remote Commands
LINE:	<i>flat</i>	NOISE:	<i>on</i>	-22.0dBm /GD,V0/; /RN,S1,L220/
INLVL:	-12.0dBm	OUTLVL:	-18.0dBm	/IO,I-120,L-180/
IMD:	<i>on</i>	2nd	43.0dB	3rd 44.0dB /NL,S1,Q430,C440/
FREQ SHIFT:	<i>off</i>		0.00Hz	/FS,S0,F0/
AJ:	<i>off</i>	LVL	10.0%	FREQ 60.00Hz /AJ,S0,L100,F6000/
PJ:	<i>off</i>	LVL	0.0deg	FREQ 0.00Hz /PJ,S0,L0,F0/
SATELLITE DELAY:	<i>on</i>			29.000ms /SD,S1,D232/
PCM:	<i>on</i>	LINKS	1	CODING <i>mu-law</i> /PC,S1,L1,C0/
PCM:		RBS	<i>on</i>	POSITION <i>first</i> /PC,R1,P1/
GHIT:	<i>off</i>	LVL	3.0dB	INT 1.0s /GH,S0,L30,I10/
GHIT:		DUR	5ms	RISE 0.2ms /GH,D5,R2/
PHIT:	<i>off</i>	LVL	45.0deg	INT 1.0s /PH,S0,L450,I10/
PHIT:		DUR	5ms	RISE 0.2ms /PH,D5,R2/
IMP:	<i>off</i>	LVL	0.0dB	rel 72.0dBm /IM,S0,L0/
IMP:		INT	0.0s	/IM,I0/
SFI:	<i>off</i>	LVL	10.0dB	FREQ 2600Hz /SF,S0,L100,F2600/

B→A IMPAIRMENTS (Submenu)

CUSTOM LINE: GAIN TYPE	<i>flat</i>	^	/GD,W0/
CUSTOM LINE: DELAY TYPE	<i>flat</i>	^	/GD,Y0/
NOISE LEVEL CORRECTION:	<i>3k flat</i>	^	/RN,W1/
IMD MODE:	<i>compressive</i>	^	/NL,M1/

CENTRAL OFFICE (Submenu 5)

A ECHO:	<i>on</i>	NEAR	40.0dB	POL <i>neg</i>	^	/EC,SA1,LA400,PA1/
A ECHO:		FAR	16.0dB	POL <i>neg</i>	^	/EC,LB160,PB1/
B ECHO:	<i>on</i>	NEAR	40.0dB	POL <i>neg</i>	^	/EC,SB1,LC400,PC1/
B ECHO:		FAR	16.0dB	POL <i>neg</i>	^	/EC,LD160,PD1/

A2.2.25. Impairment Parameters for EIA_L17c [182]:

A→B IMPAIRMENTS (Main Menu)				Remote Commands	
LINE:	<i>flat</i>	NOISE:	<i>on</i> 22.0dBm	/GD,V0;/RN,S1,L220/	
INLVL:	-12.0dBm	OUTLVL:	-18.0dBm	/IO,I-120,L-180/	
IMD:	<i>on</i>	2nd	50.0dB	3rd 51.0dB	/NL,S1,Q500,C510/
FREQ SHIFT:	<i>off</i>		0.00Hz	/FS,S0,F0/	
AJ:	<i>off</i>	LVL	10.0%	FREQ 60.00Hz	/AJ,S0,L100,F6000/
PJ:	<i>off</i>	LVL	0.0deg	FREQ 0.00Hz	/PJ,S0,L0,F0/
SATELLITE DELAY:	<i>on</i>		29.000ms	/SD,S1,D232/	
PCM:	<i>on</i>	LINKS	1	CODING <i>mu-law</i>	/PC,S1,L1,C0/
PCM:		RBS	<i>off</i>	POSITION <i>last</i>	/PC,R0,P0/
GHIT:	<i>off</i>	LVL	3.0dB	INT 1.0s	/GH,S0,L30,I10/
GHIT:		DUR	5ms	RISE 0.2ms	/GH,D5,R2/
PHIT:	<i>off</i>	LVL	45.0deg	INT 1.0s	/PH,S0,L450,I10/
PHIT:		DUR	5ms	RISE 0.2ms	/PH,D5,R2/
IMP:	<i>off</i>	LVL	0.0dB	rel 72.0dBm	/IM,S0,L0/
IMP:		INT	0.0s		/IM,I0/
SFI:	<i>off</i>	LVL	10.0dB	FREQ 2600Hz	/SF,S0,L100,F2600/

A→B IMPAIRMENTS (Submenu)			
CUSTOM LINE: GAIN TYPE	<i>flat</i>	^	/GD,W0/
CUSTOM LINE: DELAY TYPE	<i>flat</i>	^	/GD,Y0/
NOISE LEVEL CORRECTION:	<i>3k flat</i>	^	/RN,W1/
IMD MODE:	<i>compressive</i>	^	/NL,M1/

B→A IMPAIRMENTS (Main Menu)				Remote Commands	
LINE:	<i>flat</i>	NOISE:	<i>on</i> 22.0dBm	/GD,V0;/RN,S1,L220/	
INLVL:	-12.0dBm	OUTLVL:	-18.0dBm	/IO,I-120,L-180/	
IMD:	<i>on</i>	2nd	50.0dB	3rd 51.0dB	/NL,S1,Q500,C510/
FREQ SHIFT:	<i>off</i>		0.00Hz	/FS,S0,F0/	
AJ:	<i>off</i>	LVL	10.0%	FREQ 60.00Hz	/AJ,S0,L100,F6000/
PJ:	<i>off</i>	LVL	0.0de	FREQ 0.00Hz	/PJ,S0,L0,F0/
SATELLITE DELAY:	<i>on</i>		29.000ms	/SD,S1,D232/	
PCM:	<i>on</i>	LINKS	1	CODING <i>mu-law</i>	/PC,S1,L1,C0/
PCM:		RBS	<i>off</i>	POSITION <i>first</i>	/PC,R0,P1/
GHIT:	<i>off</i>	LVL	3.0dB	INT 1.0s	/GH,S0,L30,I10/
GHIT:		DUR	5ms	RISE 0.2ms	/GH,D5,R2/
PHIT:	<i>off</i>	LVL	45.0deg	INT 1.0s	/PH,S0,L450,I10/
PHIT:		DUR	5ms	RISE 0.2ms	/PH,D5,R2/
IMP:	<i>off</i>	LVL	0.0dB	rel 72.0dBm	/IM,S0,L0/
IMP:		INT	0.0s		/IM,I0/
SFI:	<i>off</i>	LVL	10.0dB	FREQ 2600Hz	/SF,S0,L100,F2600/

B→A IMPAIRMENTS (Submenu)

CUSTOM LINE: GAIN TYPE	<i>flat</i>	^	/GD,W0/
CUSTOM LINE: DELAY TYPE	<i>flat</i>	^	/GD,Y0/
NOISE LEVEL CORRECTION:	<i>3k flat</i>	^	/RN,W1/
IMD MODE:	<i>compressive</i>	^	/NL,M1/

CENTRAL OFFICE (Submenu 5)

A ECHO:	<i>on</i>	NEAR <i>40.0dB</i>	POL <i>neg</i>	^	/EC,SA1,LA400,PA1/
A ECHO:		FAR <i>20.0dB</i>	POL <i>neg</i>	^	/EC,LB200,PB1/
B ECHO:	<i>on</i>	NEAR <i>40.0dB</i>	POL <i>neg</i>	^	/EC,SB1,LC400,PC1/
B ECHO:		FAR <i>20.0dB</i>	POL <i>neg</i>	^	/EC,LD200,PD1/

A2.2.26. Impairment Parameters for EIA_L18a [182]:

A→B IMPAIRMENTS (Main Menu)

Remote Commands

LINE:	<i>flat</i>	NOISE:	<i>on</i>	<i>22.0dBm</i>	/GD,V0/; /RN,S1,L220/
INLVL:	<i>-12.0dBm</i>	OUTLVL:		<i>-20.0dBm</i>	/IO,I-120,L-200/
IMD:	<i>on</i>	2nd	<i>43.0dB</i>	3rd <i>44.0dB</i>	/NL,S1,Q430,C440/
FREQ SHIFT:	<i>off</i>		<i>0.00Hz</i>		/FS,S0,F0/
AJ:	<i>off</i>	LVL	<i>10.0%</i>	FREQ <i>60.00Hz</i>	/AJ,S0,L100,F6000/
PJ:	<i>off</i>	LVL	<i>0.0deg</i>	FREQ <i>0.00Hz</i>	/PJ,S0,L0,F0/
SATELLITE DELAY:	<i>on</i>			<i>29.000ms</i>	/SD,S1,D232/
PCM:	<i>on</i>	LINKS	<i>1</i>	CODING <i>mu-law</i>	/PC,S1,L1,C0/
PCM:		RBS	<i>on</i>	POSITION <i>last</i>	/PC,R1,P0/
GHIT:	<i>off</i>	LVL	<i>3.0dB</i>	INT <i>1.0s</i>	/GH,S0,L30,I10/
GHIT:		DUR	<i>5ms</i>	RISE <i>0.2ms</i>	/GH,D5,R2/
PHIT:	<i>off</i>	LVL	<i>45.0deg</i>	INT <i>1.0s</i>	/PH,S0,L450,I10/
PHIT:		DUR	<i>5ms</i>	RISE <i>0.2ms</i>	/PH,D5,R2/
IMP:	<i>off</i>	LVL	<i>0.0dB</i>	rel <i>72.0dBm</i>	/IM,S0,L0/
IMP:		INT	<i>0.0s</i>		/IM,I0/
SFI:	<i>off</i>	LVL	<i>10.0dB</i>	FREQ <i>2600Hz</i>	/SF,S0,L100,F2600/

A→B IMPAIRMENTS (Submenu)

CUSTOM LINE: GAIN TYPE	<i>flat</i>	^	/GD,W0/
CUSTOM LINE: DELAY TYPE	<i>flat</i>	^	/GD,Y0/
NOISE LEVEL CORRECTION:	<i>3k flat</i>	^	/RN,W1/
IMD MODE:	<i>compressive</i>	^	/NL,M1/

B→A IMPAIRMENTS (Main Menu)				Remote Commands
LINE:	<i>flat</i>	NOISE:	<i>on</i>	22.0dBm /GD,V0/; /RN,S1,L220/
INLVL:	<i>-12.0dBm</i>	OUTLVL:	<i>-20.0dBm</i>	/IO,I-120,L-200/
IMD:	<i>on</i>	2nd	<i>43.0dB</i>	3rd <i>44.0dB</i> /NL,S1,Q430,C440/
FREQ SHIFT:	<i>off</i>		<i>0.00Hz</i>	/FS,S0,F0/
AJ:	<i>off</i>	LVL	<i>10.0%</i>	FREQ <i>60.00Hz</i> /AJ,S0,L100,F6000/
PJ:	<i>off</i>	LVL	<i>0.0deg</i>	FREQ <i>0.00Hz</i> /PJ,S0,L0,F0/
SATELLITE DELAY:	<i>on</i>			<i>29.000ms</i> /SD,S1,D232/
PCM:	<i>on</i>	LINKS	<i>1</i>	CODING <i>mu-law</i> /PC,S1,L1,C0/
PCM:		RBS	<i>on</i>	POSITION <i>first</i> /PC,R1,P1/
GHIT:	<i>off</i>	LVL	<i>3.0dB</i>	INT <i>1.0s</i> /GH,S0,L30,I10/
GHIT:		DUR	<i>5ms</i>	RISE <i>0.2ms</i> /GH,D5,R2/
PHIT:	<i>off</i>	LVL	<i>45.0deg</i>	INT <i>1.0s</i> /PH,S0,L450,I10/
PHIT:		DUR	<i>5ms</i>	RISE <i>0.2ms</i> /PH,D5,R2/
IMP:	<i>off</i>	LVL	<i>0.0dB</i>	rel <i>72.0dBm</i> /IM,S0,L0/
IMP:		INT	<i>0.0s</i>	/IM,I0/
SFI:	<i>off</i>	LVL	<i>10.0dB</i>	FREQ <i>2600Hz</i> /SF,S0,L100,F2600/

B→A IMPAIRMENTS (Submenu)			
CUSTOM LINE: GAIN TYPE	<i>flat</i>	^	/GD,W0/
CUSTOM LINE: DELAY TYPE	<i>flat</i>	^	/GD,Y0/
NOISE LEVEL CORRECTION:	<i>3k flat</i>	^	/RN,W1/
IMD MODE:	<i>compressive</i>	^	/NL,M1/

CENTRAL OFFICE (Submenu 5)				
A ECHO:	<i>on</i>	NEAR	<i>40.0dB</i>	POL <i>neg</i> ^ /EC,SA1,LA400,PA1/
A ECHO:		FAR	<i>16.0dB</i>	POL <i>neg</i> ^ /EC,LB160,PB1/
B ECHO:	<i>on</i>	NEAR	<i>40.0dB</i>	POL <i>neg</i> ^ /EC,SB1,LC400,PC1/
B ECHO:		FAR	<i>16.0dB</i>	POL <i>neg</i> ^ /EC,LD160,PD1/

A2.2.27. Impairment Parameters for EIA_L18b [182]:

A→B IMPAIRMENTS (Main Menu)				Remote Commands
LINE:	<i>flat</i>	NOISE:	<i>on</i>	22.0dBm /GD,V0/; /RN,S1,L220/
INLVL:	<i>-12.0dBm</i>	OUTLVL:	<i>-18.0dBm</i>	/IO,I-120,L-180/
IMD:	<i>on</i>	2nd	<i>50.0dB</i>	3rd <i>51.0dB</i> /NL,S1,Q500,C510/
FREQ SHIFT:	<i>off</i>		<i>0.00Hz</i>	/FS,S0,F0/
AJ:	<i>off</i>	LVL	<i>10.0%</i>	FREQ <i>60.00Hz</i> /AJ,S0,L100,F6000/
PJ:	<i>off</i>	LVL	<i>0.0deg</i>	FREQ <i>0.00Hz</i> /PJ,S0,L0,F0/
SATELLITE DELAY:	<i>on</i>		<i>29.000ms</i>	/SD,S1,D232/
PCM:	<i>on</i>	LINKS	<i>1</i>	CODING <i>mu-law</i> /PC,S1,L1,C0/
PCM:		RBS	<i>on</i>	POSITION <i>last</i> /PC,R1,P0/
GHIT:	<i>off</i>	LVL	<i>3.0dB</i>	INT <i>1.0s</i> /GH,S0,L30,I10/
GHIT:		DUR	<i>5ms</i>	RISE <i>0.2ms</i> /GH,D5,R2/
PHIT:	<i>off</i>	LVL	<i>45.0deg</i>	INT <i>1.0s</i> /PH,S0,L450,I10/
PHIT:		DUR	<i>5ms</i>	RISE <i>0.2ms</i> /PH,D5,R2/
IMP:	<i>off</i>	LVL	<i>0.0dB</i>	rel <i>72.0dBm</i> /IM,S0,L0/
IMP:		INT	<i>0.0s</i>	/IM,I0/
SFI:	<i>off</i>	LVL	<i>10.0dB</i>	FREQ <i>2600Hz</i> /SF,S0,L100,F2600/

A→B IMPAIRMENTS (Submenu)				
CUSTOM LINE: GAIN TYPE	<i>flat</i>		^	/GD,W0/
CUSTOM LINE: DELAY TYPE	<i>flat</i>		^	/GD,Y0/
NOISE LEVEL CORRECTION:	<i>3k flat</i>		^	/RN,W1/
IMD MODE:	<i>compressive</i>		^	/NL,M1/

B→A IMPAIRMENTS (Main Menu)				Remote Commands
LINE:	<i>flat</i>	NOISE:	<i>on</i>	22.0dBm /GD,V0/; /RN,S1,L220/
INLVL:	<i>-12.0dBm</i>	OUTLVL:	<i>-18.0dBm</i>	/IO,I-120,L-180/
IMD:	<i>on</i>	2nd	<i>50.0dB</i>	3rd <i>51.0dB</i> /NL,S1,Q500,C510/
FREQ SHIFT:	<i>off</i>		<i>0.00Hz</i>	/FS,S0,F0/
AJ:	<i>off</i>	LVL	<i>10.0%</i>	FREQ <i>60.00Hz</i> /AJ,S0,L100,F6000/
PJ:	<i>off</i>	LVL	<i>0.0deg</i>	FREQ <i>0.00Hz</i> /PJ,S0,L0,F0/
SATELLITE DELAY:	<i>on</i>		<i>29.000ms</i>	/SD,S1,D232/
PCM:	<i>on</i>	LINKS	<i>1</i>	CODING <i>mu-law</i> /PC,S1,L1,C0/
PCM:		RBS	<i>on</i>	POSITION <i>first</i> /PC,R1,P1/
GHIT:	<i>off</i>	LVL	<i>3.0dB</i>	INT <i>1.0s</i> /GH,S0,L30,I10/
GHIT:		DUR	<i>5ms</i>	RISE <i>0.2ms</i> /GH,D5,R2/
PHIT:	<i>off</i>	LVL	<i>45.0deg</i>	INT <i>1.0s</i> /PH,S0,L450,I10/
PHIT:		DUR	<i>5ms</i>	RISE <i>0.2ms</i> /PH,D5,R2/
IMP:	<i>off</i>	LVL	<i>0.0dB</i>	rel <i>72.0dBm</i> /IM,S0,L0/
IMP:		INT	<i>0.0s</i>	/IM,I0/
SFI:	<i>off</i>	LVL	<i>10.0dB</i>	FREQ <i>2600Hz</i> /SF,S0,L100,F2600/

B→A IMPAIRMENTS (Submenu)

CUSTOM LINE: GAIN TYPE	<i>flat</i>	^	/GD,W0/
CUSTOM LINE: DELAY TYPE	<i>flat</i>	^	/GD,Y0/
NOISE LEVEL CORRECTION:	<i>3k flat</i>	^	/RN,W1/
IMD MODE:	<i>compressive</i>	^	/NL,M1/

CENTRAL OFFICE (Submenu 5)

A ECHO:	<i>on</i>	NEAR 40.0dB	POL <i>neg</i>	^	/EC,SA1,LA400,PA1/
A ECHO:		FAR 20.0dB	POL <i>neg</i>	^	/EC,LB200,PB1/
B ECHO:	<i>on</i>	NEAR 40.0dB	POL <i>neg</i>	^	/EC,SB1,LC400,PC1/
B ECHO:		FAR 20.0dB	POL <i>neg</i>	^	/EC,LD200,PD1/

A2.2.28. Impairment Parameters for EIA_L18c [182]:**A→B IMPAIRMENTS (Main Menu)****Remote Commands**

LINE:	<i>flat</i>	NOISE:	<i>on</i>	22.0dBm	/GD,V0/; /RN,S1,L220/
INLVL:	<i>-12.0dBm</i>	OUTLVL:		<i>-18.0dBm</i>	/IO,I-120,L-180/
IMD:	<i>on</i>	2nd	<i>55.0dB</i>	3rd <i>56.0dB</i>	/NL,S1,Q550,C560/
FREQ SHIFT:	<i>off</i>		<i>0.00Hz</i>		/FS,S0,F0/
AJ:	<i>off</i>	LVL	<i>10.0%</i>	FREQ <i>60.00Hz</i>	/AJ,S0,L100,F6000/
PJ:	<i>off</i>	LVL	<i>0.0deg</i>	FREQ <i>0.00Hz</i>	/PJ,S0,L0,F0/
SATELLITE DELAY:		<i>on</i>		<i>29.000ms</i>	/SD,S1,D232/
PCM:	<i>on</i>	LINKS	<i>1</i>	CODING <i>mu-law</i>	/PC,S1,L1,C0/
PCM:		RBS	<i>off</i>	POSITION <i>last</i>	/PC,R0,P0/
GHIT:	<i>off</i>	LVL	<i>3.0dB</i>	INT <i>1.0s</i>	/GH,S0,L30,I10/
GHIT:		DUR	<i>5ms</i>	RISE <i>0.2ms</i>	/GH,D5,R2/
PHIT:	<i>off</i>	LVL	<i>45.0deg</i>	INT <i>1.0s</i>	/PH,S0,L450,I10/
PHIT:		DUR	<i>5ms</i>	RISE <i>0.2ms</i>	/PH,D5,R2/
IMP:	<i>off</i>	LVL	<i>0.0dB</i>	rel <i>72.0dBm</i>	/IM,S0,L0/
IMP:		INT	<i>0.0s</i>		/IM,I0/
SFI:	<i>off</i>	LVL	<i>10.0dB</i>	FREQ <i>2600Hz</i>	/SF,S0,L100,F2600/

A→B IMPAIRMENTS (Submenu)

CUSTOM LINE: GAIN TYPE	<i>flat</i>	^	/GD,W0/
CUSTOM LINE: DELAY TYPE	<i>flat</i>	^	/GD,Y0/
NOISE LEVEL CORRECTION:	<i>3k flat</i>	^	/RN,W1/
IMD MODE:	<i>compressive</i>	^	/NL,M1/

B→A IMPAIRMENTS (Main Menu)				Remote Commands
LINE:	<i>flat</i>	NOISE:	<i>on</i>	22.0dBm /GD,V0/; /RN,S1,L220/
INLVL:	<i>-12.0dBm</i>	OUTLVL:	<i>-18.0dBm</i>	/IO,I-120,L-180/
IMD:	<i>on</i>	2nd	<i>55.0dB</i>	3rd <i>56.0dB</i> /NL,S1,Q550,C560/
FREQ SHIFT:	<i>off</i>		<i>0.00Hz</i>	/FS,S0,F0/
AJ:	<i>off</i>	LVL	<i>10.0%</i>	FREQ <i>60.00Hz</i> /AJ,S0,L100,F6000/
PJ:	<i>off</i>	LVL	<i>0.0deg</i>	FREQ <i>0.00Hz</i> /PJ,S0,L0,F0/
SATELLITE DELAY:	<i>on</i>		<i>29.000ms</i>	/SD,S1,D232/
PCM:	<i>on</i>	LINKS	<i>1</i>	CODING <i>mu-law</i> /PC,S1,L1,C0/
PCM:		RBS	<i>off</i>	POSITION <i>first</i> /PC,R0,P1/
GHIT:	<i>off</i>	LVL	<i>3.0dB</i>	INT <i>1.0s</i> /GH,S0,L30,I10/
GHIT:		DUR	<i>5ms</i>	RISE <i>0.2ms</i> /GH,D5,R2/
PHIT:	<i>off</i>	LVL	<i>45.0deg</i>	INT <i>1.0s</i> /PH,S0,L450,I10/
PHIT:		DUR	<i>5ms</i>	RISE <i>0.2ms</i> /PH,D5,R2/
IMP:	<i>off</i>	LVL	<i>0.0dB</i>	rel <i>72.0dBm</i> /IM,S0,L0/
IMP:		INT	<i>0.0s</i>	/IM,I0/
SFI:	<i>off</i>	LVL	<i>10.0dB</i>	FREQ <i>2600Hz</i> /SF,S0,L100,F2600/

B→A IMPAIRMENTS (Submenu)			
CUSTOM LINE: GAIN TYPE	<i>flat</i>	^	/GD,W0/
CUSTOM LINE: DELAY TYPE	<i>flat</i>	^	/GD,Y0/
NOISE LEVEL CORRECTION:	<i>3k flat</i>	^	/RN,W1/
IMD MODE:	<i>compressive</i>	^	/NL,M1/

CENTRAL OFFICE (Submenu 5)				
A ECHO:	<i>on</i>	NEAR	<i>40.0dB</i>	POL <i>neg</i> ^ /EC,SA1,LA400,PA1/
A ECHO:		FAR	<i>22.0dB</i>	POL <i>neg</i> ^ /EC,LB220,PB1/
B ECHO:	<i>on</i>	NEAR	<i>40.0dB</i>	POL <i>neg</i> ^ /EC,SB1,LC400,PC1/
B ECHO:		FAR	<i>22.0dB</i>	POL <i>neg</i> ^ /EC,LD220,PD1/

A2.2.29. Impairment Parameters for EIA_L19a [182]:

A→B IMPAIRMENTS (Main Menu)				Remote Commands
LINE:	<i>flat</i>	NOISE:	<i>on</i> 22.0dBm	/GD,V0;/RN,S1,L220/
INLVL:	<i>-12.0dBm</i>	OUTLVL:	<i>-20.0dBm</i>	/IO,I-120,L-200/
IMD:	<i>on</i>	2nd	<i>40.0dB</i> 3rd <i>41.0dB</i>	/NL,S1,Q400,C410/
FREQ SHIFT:	<i>off</i>		<i>0.00Hz</i>	/FS,S0,F0/
AJ:	<i>off</i>	LVL	<i>10.0%</i> FREQ <i>60.00Hz</i>	/AJ,S0,L100,F6000/
PJ:	<i>off</i>	LVL	<i>0.0deg</i> FREQ <i>0.00Hz</i>	/PJ,S0,L0,F0/
SATELLITE DELAY:	<i>on</i>		<i>28.500ms</i>	/SD,S1,D228/
PCM:	<i>on</i>	LINKS	<i>2</i> CODING <i>mu-law</i>	/PC,S1,L2,C0/
PCM:		RBS	<i>on</i> POSITION <i>last</i>	/PC,R1,P0/
GHIT:	<i>off</i>	LVL	<i>3.0dB</i> INT <i>1.0s</i>	/GH,S0,L30,I10/
GHIT:		DUR	<i>5ms</i> RISE <i>0.2ms</i>	/GH,D5,R2/
PHIT:	<i>off</i>	LVL	<i>45.0deg</i> INT <i>1.0s</i>	/PH,S0,L450,I10/
PHIT:		DUR	<i>5ms</i> RISE <i>0.2ms</i>	/PH,D5,R2/
IMP:	<i>off</i>	LVL	<i>0.0dB</i> rel <i>72.0dBm</i>	/IM,S0,L0/
IMP:		INT	<i>0.0s</i>	/IM,I0/
SFI:	<i>off</i>	LVL	<i>10.0dB</i> FREQ <i>2600Hz</i>	/SF,S0,L100,F2600/

A→B IMPAIRMENTS (Submenu)			
CUSTOM LINE: GAIN TYPE	<i>flat</i>	^	/GD,W0/
CUSTOM LINE: DELAY TYPE	<i>flat</i>	^	/GD,Y0/
NOISE LEVEL CORRECTION:	<i>3k flat</i>	^	/RN,W1/
IMD MODE:	<i>compressive</i>	^	/NL,M1/

B→A IMPAIRMENTS (Main Menu)				Remote Commands
LINE:	<i>flat</i>	NOISE:	<i>on</i> 22.0dBm	/GD,V0;/RN,S1,L220/
INLVL:	<i>-12.0dBm</i>	OUTLVL:	<i>-20.0dBm</i>	/IO,I-120,L-200/
IMD:	<i>on</i>	2nd	<i>40.0dB</i> 3rd <i>41.0dB</i>	/NL,S1,Q400,C410/
FREQ SHIFT:	<i>off</i>		<i>0.00Hz</i>	/FS,S0,F0/
AJ:	<i>off</i>	LVL	<i>10.0%</i> FREQ <i>60.00Hz</i>	/AJ,S0,L100,F6000/
PJ:	<i>off</i>	LVL	<i>0.0deg</i> FREQ <i>0.00Hz</i>	/PJ,S0,L0,F0/
SATELLITE DELAY:	<i>on</i>		<i>28.500ms</i>	/SD,S1,D228/
PCM:	<i>on</i>	LINKS	<i>2</i> CODING <i>mu-law</i>	/PC,S1,L2,C0/
PCM:		RBS	<i>on</i> POSITION <i>first</i>	/PC,R1,P1/
GHIT:	<i>off</i>	LVL	<i>3.0dB</i> INT <i>1.0s</i>	/GH,S0,L30,I10/
GHIT:		DUR	<i>5ms</i> RISE <i>0.2ms</i>	/GH,D5,R2/
PHIT:	<i>off</i>	LVL	<i>45.0deg</i> INT <i>1.0s</i>	/PH,S0,L450,I10/
PHIT:		DUR	<i>5ms</i> RISE <i>0.2ms</i>	/PH,D5,R2/
IMP:	<i>off</i>	LVL	<i>0.0dB</i> rel <i>72.0dBm</i>	/IM,S0,L0/
IMP:		INT	<i>0.0s</i>	/IM,I0/
SFI:	<i>off</i>	LVL	<i>10.0dB</i> FREQ <i>2600Hz</i>	/SF,S0,L100,F2600/

B→A IMPAIRMENTS (Submenu)

CUSTOM LINE: GAIN TYPE	<i>flat</i>	^	/GD,W0/
CUSTOM LINE: DELAY TYPE	<i>flat</i>	^	/GD,Y0/
NOISE LEVEL CORRECTION:	<i>3k flat</i>	^	/RN,W1/
IMD MODE:	<i>compressive</i>	^	/NL,M1/

CENTRAL OFFICE (Submenu 5)

A ECHO:	<i>on</i>	NEAR 40.0dB	POL <i>neg</i>	^	/EC,SA1,LA400,PA1/
A ECHO:		FAR 12.0dB	POL <i>neg</i>	^	/EC,LB120,PB1/
B ECHO:	<i>on</i>	NEAR 40.0dB	POL <i>neg</i>	^	/EC,SB1,LC400,PC1/
B ECHO:		FAR 12.0dB	POL <i>neg</i>	^	/EC,LD120,PD1/

A2.2.30. Impairment Parameters for EIA_L20a [182]:

A→B IMPAIRMENTS (Main Menu)

Remote Commands

LINE:	<i>flat</i>	NOISE: <i>on</i>	22.0dBm	/GD,V0/; /RN,S1,L220/
INLVL:	<i>-12.0dBm</i>	OUTLVL:	<i>-20.0dBm</i>	/IO,I-120,L-200/
IMD:	<i>on</i>	2nd 40.0dB	3rd 41.0dB	/NL,S1,Q400,C410/
FREQ SHIFT:	<i>off</i>	0.00Hz		/FS,S0,F0/
AJ:	<i>off</i>	LVL 10.0%	FREQ 60.00Hz	/AJ,S0,L100,F6000/
PJ:	<i>off</i>	LVL 0.0deg	FREQ 0.00Hz	/PJ,S0,L0,F0/
SATELLITE DELAY:	<i>on</i>		28.000ms	/SD,S1,D224/
PCM:	<i>on</i>	LINKS 3	CODING <i>mu-law</i>	/PC,S1,L3,C0/
PCM:		RBS <i>on</i>	POSITION <i>last</i>	/PC,R1,P0/
GHIT:	<i>off</i>	LVL 3.0dB	INT 1.0s	/GH,S0,L30,I10/
GHIT:		DUR 5ms	RISE 0.2ms	/GH,D5,R2/
PHIT:	<i>off</i>	LVL 45.0deg	INT 1.0s	/PH,S0,L450,I10/
PHIT:		DUR 5ms	RISE 0.2ms	/PH,D5,R2/
IMP:	<i>off</i>	LVL 0.0dB	rel 72.0dBm	/IM,S0,L0/
IMP:		INT 0.0s		/IM,I0/
SFI:	<i>off</i>	LVL 10.0dB	FREQ 2600Hz	/SF,S0,L100,F2600

A→B IMPAIRMENTS (Submenu)

CUSTOM LINE: GAIN TYPE	<i>flat</i>	^	/GD,W0/
CUSTOM LINE: DELAY TYPE	<i>flat</i>	^	/GD,Y0/
NOISE LEVEL CORRECTION:	<i>3k flat</i>	^	/RN,W1/
IMD MODE:	<i>compressive</i>	^	/NL,M1/

B→A IMPAIRMENTS (Main Menu)				Remote Commands	
LINE:	<i>flat</i>	NOISE:	<i>on</i>	22.0dBm	/GD,V0;/RN,S1,L220/
INLVL:	<i>-12.0dBm</i>	OUTLVL:		<i>-20.0dBm</i>	/IO,I-120,L-200/
IMD:	<i>on</i>	2nd	<i>40.0dB</i>	3rd <i>41.0dB</i>	/NL,S1,Q400,C410/
FREQ SHIFT:	<i>off</i>		<i>0.00Hz</i>		/FS,S0,F0/
AJ:	<i>off</i>	LVL	<i>10.0%</i>	FREQ <i>60.00Hz</i>	/AJ,S0,L100,F6000/
PJ:	<i>off</i>	LVL	<i>0.0deg</i>	FREQ <i>0.00Hz</i>	/PJ,S0,L0,F0/
SATELLITE DELAY:		<i>on</i>		<i>28.000ms</i>	/SD,S1,D224/
PCM:	<i>on</i>	LINKS	<i>3</i>	CODING <i>mu-law</i>	/PC,S1,L3,C0/
PCM:		RBS	<i>on</i>	POSITION <i>first</i>	/PC,R1,P1/
GHIT:	<i>off</i>	LVL	<i>3.0dB</i>	INT <i>1.0s</i>	/GH,S0,L30,I10/
GHIT:		DUR	<i>5ms</i>	RISE <i>0.2ms</i>	/GH,D5,R2/
PHIT:	<i>off</i>	LVL	<i>45.0deg</i>	INT <i>1.0s</i>	/PH,S0,L450,I10/
PHIT:		DUR	<i>5ms</i>	RISE <i>0.2ms</i>	/PH,D5,R2/
IMP:	<i>off</i>	LVL	<i>0.0dB</i>	rel <i>72.0dBm</i>	/IM,S0,L0/
IMP:		INT	<i>0.0s</i>		/IM,I0/
SFI:	<i>off</i>	LVL	<i>10.0dB</i>	FREQ <i>2600Hz</i>	/SF,S0,L100,F2600/

B→A IMPAIRMENTS (Submenu)

CUSTOM LINE: GAIN TYPE	<i>flat</i>	^	/GD,W0/
CUSTOM LINE: DELAY TYPE	<i>flat</i>	^	/GD,Y0/
NOISE LEVEL CORRECTION:	<i>3k flat</i>	^	/RN,W1/
IMD MODE:	<i>compressive</i>	^	/NL,M1/

CENTRAL OFFICE (Submenu 5)

A ECHO:	<i>on</i>	NEAR	<i>40.0dB</i>	POL <i>neg</i>	^	/EC,SA1,LA400,PA1/
A ECHO:		FAR	<i>12.0dB</i>	POL <i>neg</i>	^	/EC,LB120,PB1/
B ECHO:	<i>on</i>	NEAR	<i>40.0dB</i>	POL <i>neg</i>	^	/EC,SB1,LC400,PC1/
B ECHO:		FAR	<i>12.0dB</i>	POL <i>neg</i>	^	/EC,LD120,PD1/

A2.2.31. Impairment Parameters for EIA_L21a [182]:

A→B IMPAIRMENTS (Main Menu)				Remote Commands
LINE:	<i>cab3-AD7</i>	NOISE: <i>on</i>	22.0dBm	/GD,V36/; /RN,S1,L220/
INLVL:	<i>-12.0dBm</i>	OUTLVL:	<i>-20.0dBm</i>	/IO,I-120,L-200/
IMD:	<i>on</i>	2nd <i>60.0dB</i>	3rd <i>58.0dB</i>	/NL,S1,Q600,C580/
FREQ SHIFT:	<i>off</i>	0.00Hz		/FS,S0,F0/
AJ:	<i>off</i>	LVL <i>10.0%</i>	FREQ <i>60.00Hz</i>	/AJ,S0,L100,F6000/
PJ:	<i>off</i>	LVL <i>0.0deg</i>	FREQ <i>0.00Hz</i>	/PJ,S0,L0,F0/
SATELLITE DELAY:	<i>on</i>		<i>7.000ms</i>	/SD,S1,D56/
PCM:	<i>off</i>	LINKS <i>1</i>	CODING <i>mu-law</i>	/PC,S0,L1,C0/
PCM:	RBS <i>off</i>		POSITION <i>last</i>	/PC,R0,P0/
GHIT:	<i>off</i>	LVL <i>3.0dB</i>	INT <i>1.0s</i>	/GH,S0,L30,I10/
GHIT:	DUR <i>5ms</i>		RISE <i>0.2ms</i>	/GH,D5,R2/
PHIT:	<i>off</i>	LVL <i>45.0deg</i>	INT <i>1.0s</i>	/PH,S0,L450,I10/
PHIT:	DUR <i>5ms</i>		RISE <i>0.2ms</i>	/PH,D5,R2/
IMP:	<i>off</i>	LVL <i>0.0dB</i>	rel <i>72.0dBm</i>	/TM,S0,L0/
IMP:	INT <i>0.0s</i>			/TM,I0/
SFI:	<i>off</i>	LVL <i>10.0dB</i>	FREQ <i>2600Hz</i>	/SF,S0,L100,F2600/

A→B IMPAIRMENTS (Submenu)			
CUSTOM LINE: GAIN TYPE	<i>flat</i>	^	/GD,W0/
CUSTOM LINE: DELAY TYPE	<i>flat</i>	^	/GD,Y0/
NOISE LEVEL CORRECTION:	<i>3k flat</i>	^	/RN,W1/
IMD MODE:	<i>compressive</i>	^	/NL,M1/

B→A IMPAIRMENTS (Main Menu)				Remote Commands
LINE:	<i>cab3-AD7</i>	NOISE: <i>on</i>	22.0dBm	/GD,V36/; /RN,S1,L220/
INLVL:	<i>-12.0dBm</i>	OUTLVL:	<i>-20.0dBm</i>	/IO,I-120,L-200/
IMD:	<i>on</i>	2nd <i>60.0dB</i>	3rd <i>58.0dB</i>	/NL,S1,Q600,C580/
FREQ SHIFT:	<i>off</i>	0.00Hz		/FS,S0,F0/
AJ:	<i>off</i>	LVL <i>10.0%</i>	FREQ <i>60.00Hz</i>	/AJ,S0,L100,F6000/
PJ:	<i>off</i>	LVL <i>0.0deg</i>	FREQ <i>0.00Hz</i>	/PJ,S0,L0,F0/
SATELLITE DELAY:	<i>on</i>		<i>7.000ms</i>	/SD,S1,D56/
PCM:	<i>off</i>	LINKS <i>1</i>	CODING <i>mu-law</i>	/PC,S0,L1,C0/
PCM:	RBS <i>off</i>		POSITION <i>first</i>	/PC,R0,P1/
GHIT:	<i>off</i>	LVL <i>3.0dB</i>	INT <i>1.0s</i>	/GH,S0,L30,I10/
GHIT:	DUR <i>5ms</i>		RISE <i>0.2ms</i>	/GH,D5,R2/
PHIT:	<i>off</i>	LVL <i>45.0deg</i>	INT <i>1.0s</i>	/PH,S0,L450,I10/
PHIT:	DUR <i>5ms</i>		RISE <i>0.2ms</i>	/PH,D5,R2/
IMP:	<i>off</i>	LVL <i>0.0dB</i>	rel <i>72.0dBm</i>	/TM,S0,L0/
IMP:	INT <i>0.0s</i>			/TM,I0/
SFI:	<i>off</i>	LVL <i>10.0dB</i>	FREQ <i>2600Hz</i>	/SF,S0,L100,F2600/

B→A IMPAIRMENTS (Submenu)

CUSTOM LINE: GAIN TYPE	<i>flat</i>	^	/GD,W0/
CUSTOM LINE: DELAY TYPE	<i>flat</i>	^	/GD,Y0/
NOISE LEVEL CORRECTION:	<i>3k flat</i>	^	/RN,W1/
IMD MODE:	<i>compressive</i>	^	/NL,M1/

CENTRAL OFFICE (Submenu 5)

A ECHO:	<i>on</i>	NEAR <i>40.0dB</i>	POL <i>neg</i>	^	/EC,SA1,LA400,PA1/
A ECHO:		FAR <i>12.0dB</i>	POL <i>neg</i>	^	/EC,LB120,PB1/
B ECHO:	<i>on</i>	NEAR <i>40.0dB</i>	POL <i>neg</i>	^	/EC,SB1,LC400,PC1/
B ECHO:		FAR <i>12.0dB</i>	POL <i>neg</i>	^	/EC,LD120,PD1/

A2.2.32. Impairment Parameters for EIA_L22a [182]:**A→B IMPAIRMENTS (Main Menu)****Remote Commands**

LINE:	<i>cab3-AD7</i>	NOISE: <i>on</i>	<i>22.0dBm</i>	/GD,V36/; /RN,S1,L220/
INLVL:	<i>-12.0dBm</i>	OUTLVL:	<i>-20.0dBm</i>	/IO,I-120,L-200/
IMD:	<i>on</i>	2nd <i>43.0dB</i>	3rd <i>44.0dB</i>	/NL,S1,Q430,C440/
FREQ SHIFT:	<i>off</i>	<i>0.00Hz</i>		/FS,S0,F0/
AJ:	<i>off</i>	LVL <i>10.0%</i>	FREQ <i>60.00Hz</i>	/AJ,S0,L100,F6000/
PJ:	<i>off</i>	LVL <i>0.0deg</i>	FREQ <i>0.00Hz</i>	/PJ,S0,L0,F0/
SATELLITE DELAY:		<i>on</i>	<i>29.000ms</i>	/SD,S1,D232/
PCM:	<i>on</i>	LINKS <i>1</i>	CODING <i>mu-law</i>	/PC,S1,L1,C0/
PCM:		RBS <i>off</i>	POSITION <i>last</i>	/PC,R0,P0/
GHIT:	<i>off</i>	LVL <i>3.0dB</i>	INT <i>1.0s</i>	/GH,S0,L30,I10/
GHIT:		DUR <i>5ms</i>	RISE <i>0.2ms</i>	/GH,D5,R2/
PHIT:	<i>off</i>	LVL <i>45.0deg</i>	INT <i>1.0s</i>	/PH,S0,L450,I10/
PHIT:		DUR <i>5ms</i>	RISE <i>0.2ms</i>	/PH,D5,R2/
IMP:	<i>off</i>	LVL <i>0.0dB</i>	rel <i>72.0dBm</i>	/IM,S0,L0/
IMP:		INT <i>0.0s</i>		/IM,I0/
SFI:	<i>off</i>	LVL <i>10.0dB</i>	FREQ <i>2600Hz</i>	/SF,S0,L100,F2600/

A→B IMPAIRMENTS (Submenu)

CUSTOM LINE: GAIN TYPE	<i>flat</i>	^	/GD,W0/
CUSTOM LINE: DELAY TYPE	<i>flat</i>	^	/GD,Y0/
NOISE LEVEL CORRECTION:	<i>3k flat</i>	^	/RN,W1/
IMD MODE:	<i>compressive</i>	^	/NL,M1/

B→A IMPAIRMENTS (Main Menu)				Remote Commands
LINE:	<i>cab3-AD7</i>	NOISE:	<i>on</i>	22.0dBm /GD,V36/; /RN,S1,L220/
INLVL:	<i>-12.0dBm</i>	OUTLVL:	<i>-20.0dBm</i>	/IO,I-120,L-200/
IMD:	<i>on</i>	2nd	<i>43.0dB</i>	3rd <i>44.0dB</i> /NL,S1,Q430,C440/
FREQ SHIFT:	<i>off</i>		<i>0.00Hz</i>	/FS,S0,F0/
AJ:	<i>off</i>	LVL	<i>10.0%</i>	FREQ <i>60.00Hz</i> /AJ,S0,L100,F6000/
PJ:	<i>off</i>	LVL	<i>0.0deg</i>	FREQ <i>0.00Hz</i> /PJ,S0,L0,F0/
SATELLITE DELAY:	<i>on</i>			<i>29.000ms</i> /SD,S1,D232/
PCM:	<i>on</i>	LINKS	<i>1</i>	CODING <i>mu-law</i> /PC,S1,L1,C0/
PCM:		RBS	<i>off</i>	POSITION <i>first</i> /PC,R0,P1/
GHIT:	<i>off</i>	LVL	<i>3.0dB</i>	INT <i>1.0s</i> /GH,S0,L30,I10/
GHIT:		DUR	<i>5ms</i>	RISE <i>0.2ms</i> /GH,D5,R2/
PHIT:	<i>off</i>	LVL	<i>45.0deg</i>	INT <i>1.0s</i> /PH,S0,L450,I10/
PHIT:		DUR	<i>5ms</i>	RISE <i>0.2ms</i> /PH,D5,R2/
IMP:	<i>off</i>	LVL	<i>0.0dB</i>	rel <i>2.0dBm</i> /TM,S0,L0/
IMP:		INT	<i>0.0s</i>	/TM,I0/
SFI:	<i>off</i>	LVL	<i>10.0dB</i>	FREQ <i>2600Hz</i> /SF,S0,L100,F2600/

B→A IMPAIRMENTS (Submenu)			
CUSTOM LINE: GAIN TYPE	<i>flat</i>	^	/GD,W0/
CUSTOM LINE: DELAY TYPE	<i>flat</i>	^	/GD,Y0/
NOISE LEVEL CORRECTION:	<i>3k flat</i>	^	/RN,W1/
IMD MODE:	<i>compressive</i>	^	/NL,M1/

CENTRAL OFFICE (Submenu 5)				
A ECHO:	<i>on</i>	NEAR	<i>40.0dB</i>	POL <i>neg</i> ^ /EC,SA1,LA400,PA1/
A ECHO:		FAR	<i>12.0dB</i>	POL <i>neg</i> ^ /EC,LB120,PB1/
B ECHO:	<i>on</i>	NEAR	<i>40.0dB</i>	POL <i>neg</i> ^ /EC,SB1,LC400,PC1/
B ECHO:		FAR	<i>12.0dB</i>	POL <i>neg</i> ^ /EC,LD120,PD1/

A2.2.33. Impairment Parameters for EIA_L23a [182]:

A→B IMPAIRMENTS (Main Menu)				Remote Commands
LINE:	<i>custom</i>	NOISE:	<i>on</i> 30.0dBm	/GD,V25/; /RN,S1,L300/
INLVL:	<i>-12.0dBm</i>	OUTLVL:	<i>-21.0dBm</i>	/IO,I-120,L-210/
IMD:	<i>on</i>	2nd	<i>43.0dB</i> 3rd <i>44.0dB</i>	/NL,S1,Q430,C440/
FREQ SHIFT:	<i>on</i>		<i>0.20Hz</i>	/FS,S1,F25/
AJ:	<i>off</i>	LVL	<i>10.0%</i> FREQ <i>60.00Hz</i>	/AJ,S0,L100,F6000/
PJ:	<i>on</i>	LVL	<i>3.0deg</i> FREQ <i>60.00Hz</i>	/PJ,S1,L30,F6000/
SATELLITE DELAY:	<i>on</i>		<i>7.500ms</i>	/SD,S1,D60/
PCM:	<i>off</i>	LINKS	<i>1</i> CODING <i>mu-law</i>	/PC,S0,L1,C0/
PCM:		RBS	<i>off</i> POSITION <i>last</i>	/PC,R0,P0/
GHIT:	<i>off</i>	LVL	<i>3.0dB</i> INT <i>1.0s</i>	/GH,S0,L30,I10/
GHIT:		DUR	<i>5ms</i> RISE <i>0.2ms</i>	/GH,D5,R2/
PHIT:	<i>off</i>	LVL	<i>45.0deg</i> INT <i>1.0s</i>	/PH,S0,L450,I10/
PHIT:		DUR	<i>5ms</i> RISE <i>0.2ms</i>	/PH,D5,R2/
IMP:	<i>off</i>	LVL	<i>0.0dB</i> rel <i>72.0dBm</i>	/IM,S0,L0/
IMP:		INT	<i>0.0s</i>	/IM,I0/
SFI:	<i>off</i>	LVL	<i>10.0dB</i> FREQ <i>2600Hz</i>	/SF,S0,L100,F2600/

A→B IMPAIRMENTS (Submenu)			
CUSTOM LINE: GAIN TYPE	<i>jpn5-AD4</i>	^	/GD,W47/
CUSTOM LINE: DELAY TYPE	<i>jp1-EDD1</i>	^	/GD,Y43/
NOISE LEVEL CORRECTION:	<i>3k flat</i>	^	/RN,W1/
IMD MODE:	<i>compressive</i>	^	/NL,M1/

B→A IMPAIRMENTS (Main Menu)				Remote Commands
LINE:	<i>custom</i>	NOISE:	<i>on</i> 30.0dBm	/GD,V25/; /RN,S1,L300/
INLVL:	<i>-12.0dBm</i>	OUTLVL:	<i>-21.0dBm</i>	/IO,I-120,L-210/
IMD:	<i>on</i>	2nd	<i>43.0dB</i> 3rd <i>44.0dB</i>	/NL,S1,Q430,C440/
FREQ SHIFT:	<i>on</i>		<i>-0.20Hz</i>	/FS,S1,F-20/
AJ:	<i>off</i>	LVL	<i>10.0%</i> FREQ <i>60.00Hz</i>	/AJ,S0,L100,F6000/
PJ:	<i>on</i>	LVL	<i>3.0deg</i> FREQ <i>60.00Hz</i>	/PJ,S1,L30,F6000/
SATELLITE DELAY:	<i>on</i>		<i>7.500ms</i>	/SD,S1,D60/
PCM:	<i>off</i>	LINKS	<i>1</i> CODING <i>mu-law</i>	/PC,S0,L1,C0/
PCM:		RBS	<i>off</i> POSITION <i>first</i>	/PC,R0,P1/
GHIT:	<i>off</i>	LVL	<i>3.0dB</i> INT <i>1.0s</i>	/GH,S0,L30,I10/
GHIT:		DUR	<i>5ms</i> RISE <i>0.2ms</i>	/GH,D5,R2/
PHIT:	<i>off</i>	LVL	<i>45.0deg</i> INT <i>1.0s</i>	/PH,S0,L450,I10/
PHIT:		DUR	<i>5ms</i> RISE <i>0.2ms</i>	/PH,D5,R2/
IMP:	<i>off</i>	LVL	<i>0.0dB</i> rel <i>72.0dBm</i>	/IM,S0,L0/
IMP:		INT	<i>0.0s</i>	/IM,I0/
SFI:	<i>off</i>	LVL	<i>10.0dB</i> FREQ <i>2600Hz</i>	/SF,S0,L100,F2600/

B→A IMPAIRMENTS (Submenu)

CUSTOM LINE: GAIN TYPE	<i>jpn5-AD4</i>	^	/GD,W47/
CUSTOM LINE: DELAY TYPE	<i>jp1-EDD1</i>	^	/GD,Y43/
NOISE LEVEL CORRECTION:	<i>3k flat</i>	^	/RN,W1/
IMD MODE:	<i>compressive</i>	^	/NL,M1/

CENTRAL OFFICE (Submenu 5)

A ECHO:	<i>on</i>	NEAR <i>40.0dB</i>	POL <i>neg</i>	^	/EC,SA1,LA400,PA1/
A ECHO:		FAR <i>16.0dB</i>	POL <i>neg</i>	^	/EC,LB160,PB1/
B ECHO:	<i>on</i>	NEAR <i>40.0dB</i>	POL <i>neg</i>	^	/EC,SB1,LC400,PC1/
B ECHO:		FAR <i>16.0dB</i>	POL <i>neg</i>	^	/EC,LD160,PD1/

A2.2.34. Impairment Parameters for EIA_L24a [182]:

A→B IMPAIRMENTS (Main Menu)

Remote Commands

LINE:	<i>custom</i>	NOISE:	<i>on</i>	<i>33.0dBm</i>	/GD,V25/; /RN,S1,L330/
INLVL:	<i>-12.0dBm</i>	OUTLVL:		<i>-20.0dBm</i>	/IO,I-120,L-200/
IMD:	<i>on</i>	2nd	<i>43.0dB</i>	3rd <i>44.0dB</i>	/NL,S1,Q430,C440/
FREQ SHIFT:	<i>off</i>		<i>0.00Hz</i>		/FS,S0,F0/
AJ:	<i>off</i>	LVL	<i>10.0%</i>	FREQ <i>60.00Hz</i>	/AJ,S0,L100,F6000/
PJ:	<i>on</i>	LVL	<i>3.0deg</i>	FREQ <i>60.00Hz</i>	/PJ,S1,L30,F6000/
SATELLITE DELAY:		<i>on</i>		<i>29.500ms</i>	/SD,S1,D236/
PCM:	<i>on</i>	LINKS	<i>1</i>	CODING <i>mu-law</i>	/PC,S1,L1,C0/
PCM:		RBS	<i>off</i>	POSITION <i>last</i>	/PC,R0,P0/
GHIT:	<i>off</i>	LVL	<i>3.0dB</i>	INT <i>1.0s</i>	/GH,S0,L30,I10/
GHIT:		DUR	<i>5ms</i>	RISE <i>0.2ms</i>	/GH,D5,R2/
PHIT:	<i>off</i>	LVL	<i>45.0deg</i>	INT <i>1.0s</i>	/PH,S0,L450,I10/
PHIT:		DUR	<i>5ms</i>	RISE <i>0.2ms</i>	/PH,D5,R2/
IMP:	<i>off</i>	LVL	<i>0.0dB</i>	rel <i>72.0dBm</i>	/TM,S0,L0/
IMP:		INT	<i>0.0s</i>		/TM,I0/
SFI:	<i>off</i>	LVL	<i>10.0dB</i>	FREQ <i>2600Hz</i>	/SF,S0,L100,F2600/

A→B IMPAIRMENTS (Submenu)

CUSTOM LINE: GAIN TYPE	<i>jpn4-AD3</i>	^	/GD,W46/
CUSTOM LINE: DELAY TYPE	<i>jp1-EDD1</i>	^	/GD,Y43/
NOISE LEVEL CORRECTION:	<i>3k flat</i>	^	/RN,W1/
IMD MODE:	<i>compressive</i>	^	/NL,M1/

B→A IMPAIRMENTS (Main Menu)				Remote Commands	
LINE:	<i>custom</i>	NOISE:	<i>on</i>	33.0dBm	/GD,V25/; /RN,S1,L330/
INLVL:	<i>-12.0dBm</i>	OUTLVL:		<i>-20.0dBm</i>	/IO,I-120,L-200/
IMD:	<i>on</i>	2nd	<i>43.0dB</i>	3rd <i>44.0dB</i>	/NL,S1,Q430,C440/
FREQ SHIFT:	<i>off</i>		<i>0.00Hz</i>		/FS,S0,F0/
AJ:	<i>off</i>	LVL	<i>10.0%</i>	FREQ <i>60.00Hz</i>	/AJ,S0,L100,F6000/
PJ:	<i>on</i>	LVL	<i>3.0deg</i>	FREQ <i>61.00Hz</i>	/PJ,S1,L30,F6100/
SATELLITE DELAY:			<i>on</i>	<i>29.500ms</i>	/SD,S1,D236/
PCM:	<i>on</i>	LINKS	<i>1</i>	CODING <i>mu-law</i>	/PC,S1,L1,C0/
PCM:		RBS	<i>off</i>	POSITION <i>first</i>	/PC,R0,P1/
GHIT:	<i>off</i>	LVL	<i>3.0dB</i>	INT <i>1.0s</i>	/GH,S0,L30,I10/
GHIT:		DUR	<i>5ms</i>	RISE <i>0.2ms</i>	/GH,D5,R2/
PHIT:	<i>off</i>	LVL	<i>45.0deg</i>	INT <i>1.0s</i>	/PH,S0,L450,I10/
PHIT:		DUR	<i>5ms</i>	RISE <i>0.2ms</i>	/PH,D5,R2/
IMP:	<i>off</i>	LVL	<i>0.0dB</i>	rel <i>72.0dBm</i>	/IM,S0,L0/
IMP:		INT	<i>0.0s</i>		/IM,I0/
SFI:	<i>off</i>	LVL	<i>10.0dB</i>	FREQ <i>2600Hz</i>	/SF,S0,L100,F2600/

B→A IMPAIRMENTS (Submenu)

CUSTOM LINE: GAIN TYPE	<i>jpn4-AD3</i>	^	/GD,W46/
CUSTOM LINE: DELAY TYPE	<i>jp1-EDD1</i>	^	/GD,Y43/
NOISE LEVEL CORRECTION:	<i>3k flat</i>	^	/RN,W1/
IMD MODE:	<i>compressive</i>	^	/NL,M1/

CENTRAL OFFICE (Submenu 5)

A ECHO:	<i>on</i>	NEAR <i>40.0dB</i>	POL <i>neg</i>	^	/EC,SA1,LA400,PA1/
A ECHO:		FAR <i>16.0dB</i>	POL <i>neg</i>	^	/EC,LB160,PB1/
B ECHO:	<i>on</i>	NEAR <i>40.0dB</i>	POL <i>neg</i>	^	/EC,SB1,LC400,PC1/
B ECHO:		FAR <i>16.0dB</i>	POL <i>neg</i>	^	/EC,LD160,PD1/

A2.2.35. Impairment Parameters for USA Average:

A→B and B→A IMPAIRMENTS (Main Menu)				Remote Commands
LINE:	<i>eia_b2</i>	NOISE: <i>on</i>	32.0dBm	/GD,V10;/RN,S1,L320/
INLVL:	<i>-10.0dBm</i>	OUTLVL:	<i>-23.0dBm</i>	/IO,I-100,L-230/
IMD:	<i>on</i>	2nd <i>52.0dB</i>	3rd <i>50.0dB</i>	/NL,S1,Q520,C500/
FREQ SHIFT:	<i>on</i>	<i>1.25Hz</i>		/FS,S1,F125/
AJ:	<i>off</i>	LVL <i>10.0%</i>	FREQ <i>60.00Hz</i>	/AJ,S0,L100,F6000/
PJ:	<i>on</i>	LVL <i>8.0deg</i>	FREQ <i>120.00Hz</i>	/PJ,S1,L80,F12000/
SATELLITE DELAY:	<i>off</i>		<i>550.000ms</i>	/SD,S0,D4400/
PCM:	<i>off</i>	LINKS <i>1</i>	CODING <i>mu-law</i>	/PC,S0,L1,C0/
PCM:		RBS <i>off</i>	POSITION <i>last</i>	/PC,R0,P0/
GHIT:	<i>off</i>	LVL <i>3.0dB</i>	INT <i>1.0s</i>	/GH,S0,L30,I10/
GHIT:		DUR <i>5ms</i>	RISE <i>0.2ms</i>	/GH,D5,R2/
PHIT:	<i>off</i>	LVL <i>45.0deg</i>	INT <i>1.0s</i>	/PH,S0,L450,I10/
PHIT:		DUR <i>5ms</i>	RISE <i>0.2ms</i>	/PH,D5,R2/
IMP:	<i>off</i>	LVL <i>40.0dB</i>	rel <i>27.0dBm</i>	/IM,S0,L400/
IMP:		INT <i>1.0s</i>		/IM,I10/
SFI:	<i>off</i>	LVL <i>10.0dB</i>	FREQ <i>2600Hz</i>	/SF,S0,L100,F2600/

A→B and B→A IMPAIRMENTS (Submenu)			
CUSTOM LINE: GAIN TYPE	<i>flat</i>	^	/GD,W0/
CUSTOM LINE: DELAY TYPE	<i>flat</i>	^	/GD,Y0/
NOISE LEVEL CORRECTION:	<i>c-msg</i>	^	/RN,W0/
IMD MODE:	<i>expansive</i>	^	/NL,M0/

CENTRAL OFFICE (Submenu 5)					
A ECHO:	<i>off</i>	NEAR <i>21.0dB</i>	POL <i>pos</i>	^	/EC,SA0,LA210,PA0/
A ECHO:		FAR <i>21.0dB</i>	POL <i>pos</i>	^	/EC,LB210,PB0/
B ECHO:	<i>off</i>	NEAR <i>21.0dB</i>	POL <i>pos</i>	^	/EC,SB0,LC210,PC0/
B ECHO:		FAR <i>21.0dB</i>	POL <i>pos</i>	^	/EC,LD210,PD0/

A2.2.36. Impairment Parameters for USA Worst Case:

A→B and B→A IMPAIRMENTS (Main Menu)				Remote Commands
LINE:	3002	NOISE: on	41.0dBm	/GD,V2/; /RN,S1,L410/
INLVL:	-10.0dBm	OUTLVL:	-34.0dBm	/IO,I-100,L-340/
IMD:	on	2nd 34.0dB	3rd 34.0dB	/NL,S1,Q340,C340/
FREQ SHIFT:	on	2.00Hz		/FS,S1,F200/
AJ:	off	LVL 10.0%	FREQ 60.00Hz	/AJ,S0,L100,F6000/
PJ:	on	LVL 23.0deg	FREQ 120.00Hz	/PJ,S1,L230,F12000/
SATELLITE DELAY:		off	550.000ms	/SD,S0,D4400/
PCM:	off	LINKS 1	CODING <i>mu-law</i>	/PC,S0,L1,C0/
PCM:		RBS off	POSITION <i>last</i>	/PC,R0,P0/
GHIT:	off	LVL 3.0dB	INT 1.0s	/GH,S0,L30,I10/
GHIT:		DUR 5ms	RISE 0.2ms	/GH,D5,R2/
PHIT:	off	LVL 45.0deg	INT 1.0s	/PH,S0,L450,I10/
PHIT:		DUR 5ms	RISE 0.2ms	/PH,D5,R2/
IMP:	off	LVL 40.0dB	rel 16.0dBm	/IM,S0,L400/
IMP:		INT 1.0s		/IM,I10/
SFI:	off	LVL 10.0dB	FREQ 2600Hz	/SF,S0,L100,F2600/

A→B and B→A IMPAIRMENTS (Submenu)			
CUSTOM LINE: GAIN TYPE	<i>flat</i>	^	/GD,W0/
CUSTOM LINE: DELAY TYPE	<i>flat</i>	^	/GD,Y0/
NOISE LEVEL CORRECTION:	<i>c-msg</i>	^	/RN,W0/
IMD MODE:	<i>expansive</i>	^	/NL,M0/

This page intentionally left blank.

APPENDIX 3: PERFORMANCE VERIFICATION PROCEDURE

The purpose of this procedure is to provide a means of adequately verifying proper operation of TAS 100 Series Telephone Network Simulators. This procedure can be utilized for all models in the TAS 100 Series.

These verification procedures verify that the analog signal processing portions of a TAS 100 Series unit are functioning within the technical specifications stated for the units. No verification is required for the digital signal processing (DSP) portions of the TAS 100 Series units.

This verification procedure contains the following operations:

1. Output signal verification and signal level measurement in 4-wire mode.
2. Output signal verification and signal level measurement in 2-wire mode.
3. White noise level setting verification.
4. Central office functions verification and central office signaling verification.

A3.1. Required Verification Equipment

The following equipment is required to perform the quick verification procedure:

- HP 4935A Transmission Impairment Measuring Set (TIMS), or equivalent.
- Two cables capable of connecting the TIMS TRMT/RCV jacks (310 plugs used with HP 4935A) to the TAS terminal strips on the rear panel of the TAS 100 Series unit.
- HP 3478A multimeter or equivalent.
- A cable capable of connecting the multimeter input and common jacks (banana plugs used with HP 3478A) to the TAS terminal strips on the rear panel of the TAS 100 Series unit.
- A precision 100-ohm (2-watt minimum) resistor.
- A dial pulse or touch-tone phone equipped with an RJ-45 modular plug.

A3.2. Pre-Verification Operations TAS 100 Unit

Power on the TAS 100 Series unit. After the unit performs its SELF TEST/CALIBRATION, bring up the Recall menu by pressing the Recall function key. Press the value + key (or value - key) until "RECALL: CO+IMP factory default" is displayed. Press the Recall key again. The display should indicate "RECALLED FROM factory default". The NETWORK "private 4w" LED should be lit.

Press the A→B Impairments function key and then press the menu navigation ↓ key to verify that "INLVL: -10.0 dBm OUTLVL: -18.0 dBm" is displayed. (These are the levels that are used during the verification operation procedures.)

TIMS Unit

Power on the TIMS (use a calibrated TIMS).

Set the TIMS transmit controls to transmit a 1004 Hz tone at 600 ohms. Set the transmit level to -10.0 dBm.

Set the TIMS receive controls to receive a 1004 Hz tone at 600 ohms.

A3.3. Output Signal Verifications and Signal Level Measurements

A3.3.1. Output Signal Verification & Signal Level Measurement in 4-Wire Mode

Connect the TIMS transmit to the TAS 100 Series unit station A rear terminal strip, terminals 1 (R1) and 2 (T1). Connect the TIMS receive to the TAS 100 Series unit station B rear terminal strip, terminals 7 (T) and 8 (R).

With the TIMS transmitting the 1004 Hz tone at -10 dBm (600 ohms), the TIMS should report a received signal of -18.0 dBm \pm 0.6 dB (600 ohms).

Press the Measure function key on the front panel of the TAS 100 Series unit. The display should indicate a "LEVEL" of -10.0 \pm 0.6 dBm and "SOURCE a xmit".

Press the value + (or value -) key on the TAS 100 Series unit front panel until "SOURCE b rev 4w" is displayed. The display should indicate a "LEVEL" of -18.0 \pm 0.6 dBm.

Remove the connections at the TAS 100 Series unit rear terminal strip. Connect the TIMS transmit to the TAS 100 Series unit station B rear terminal strip, terminals 1 (R1) and 2 (T1). Connect the TIMS receive to TAS 100 Series unit station A rear terminal strip, terminals 7 (T) and 8 (R).

With the TIMS transmitting the 1004 Hz tone at -10 dBm (600 ohms), the TIMS should report a received signal of -18.0 dBm \pm 0.6 dB (600 ohms).

$$B \text{ XMIT} = -10 \pm .6$$

Press the value + (or value -) key on the TAS 100 Series unit front panel until "SOURCE a rcv 4w" is displayed. The display should indicate a "LEVEL" of -18.0 ± 0.6 dBm.

A3.3.2. Output Signal Verification & Signal Level Measurement in 2-Wire Mode

Press the Central Office function key on the front panel of the TAS 100 Series unit. Press the menu navigation ↓ key until the display indicates "LINE MODE:private 2w".

Connect the TIMS transmit to the TAS 100 Series unit station B rear terminal strip, terminals 4 (R) and 5 (T). Connect the TIMS receive to the TAS 100 Series unit station A rear terminal strip, terminals 4 (R) and 5 (T).

With the TIMS transmitting the 1004 Hz tone at -10 dBm (600 ohms), the TIMS should report a received signal of -18.0 dBm ± 0.6 dB (600 ohms).

Press the Measure function key on the front panel of the TAS 100 Series unit. Press the value + (or value -) key on the front panel of the TAS 100 Series unit until "SOURCE a rcv 2w" is displayed. The display should indicate a "LEVEL" of -18.0 ± 0.6 dBm.

Remove the connections at the TAS 100 Series unit rear terminal strip. Connect the TIMS transmit to the TAS 100 Series unit station A rear terminal strip, terminals 4 (R) and 5 (T). Connect the TIMS receive to the TAS 100 Series unit station B rear terminal strip, terminals 4 (R) and 5 (T).

With the TIMS transmitting the 1004 Hz tone at -10 dBm (600 ohms), the TIMS should report a received signal of -18.0 dBm ± 0.6 dB (600 ohms).

Press the value + (or value -) key on the front panel of the TAS 100 Series unit until "SOURCE b rcv 2w" is displayed. The display should indicate a "LEVEL" of -18.0 ± 0.6 dBm.

A3.4. White Noise Level Setting Verification

NOTE: The white noise verification procedure detailed below should be used for all TAS 100 Series models **except the Model 150** (this model does not contain an impairments generator).

Press the Central Office function key on the front panel of the TAS 100 Series unit. Press the value - key until the display indicates "LINE MODE:private 4w".

Connect the TIMS transmit to the TAS 100 Series unit station A rear terminal strip, terminals 1 (R1) and 2 (T1). Connect the TIMS receive to the TAS 100 Series unit station B rear terminal strip, terminals 7 (T) and 8 (R).

Use the C-message weighting filter to set the TIMS to measure received noise. (Set the TIMS transmit to a quiet termination connection if this is not automatically done by the TIMS when its noise measurement mode is selected.)

Press the A→B Impairments function key on the front panel of the TAS 100 Series unit. The display should indicate "LINE:flat NOISE:off 32.0 dBm". Use the menu navigation keys and the value +/- keys to change the display to "LINE:flat NOISE:on 62.0 dBm".

The TIMS should report a received noise level of 62.0 dBm \pm 1.5 dB.

If the TAS 100 Series unit is a model 151 or 181, the white noise level setting verification procedure is complete. Remove the TIMS connections from the TAS 100 Series unit and proceed to the central office verification procedures.

NOTE: Perform the operations detailed in the next four paragraphs only if the TAS 100 Series unit is a model 152 or 182.

Remove the connections at the TAS 100 Series unit rear terminal strip. Connect the TIMS transmit to the TAS 100 Series unit station B rear terminal strip, terminals 1 (R1) and 2 (T1). Connect the TIMS receive to the TAS 100 Series unit station A rear terminal strip, terminals 7 (T) and 8 (R).

Press the B→A Impairments function key on the front panel of the TAS 100 Series unit. The display should indicate "LINE:flat NOISE:off 32.0 dBm". Use the menu navigation keys and the value +/- keys to change the display to "LINE:flat NOISE:on 62.0 dBm".

The TIMS should report a received noise level of 62.0 dBm \pm 1.5 dB. Remove the TIMS connections from the TAS 100 Series unit.

A3.5. Central Office Functions and Central Office Signaling Verifications

Loop Current Verification

CAUTION: Measurements obtained during the procedures detailed below are performed at locations in the unit with hazardous voltages. When instructed to turn off the TAS 100 AC power, be sure to follow that directive.

Turn off the TAS 100 AC power. Connect a precision 100-ohm (2-watt minimum) resistor across the TAS 100 station A rear terminals 4 (R) and 5 (T).

Connect the multimeter (set for DC voltage measurements) input jack to the TAS 100 station A rear terminal 5 (T). Connect the multimeter common jack to the TAS 100 station A terminal 4 (R).

Power on the TAS 100 unit. After the unit performs its SELF TEST/CALIBRATION, press the Recall FUNCTION key. Press the value + (or value -) key until "RECALL: CO+IMP factory default" is displayed. Press the Recall key again. The display should indicate "RECALLED FROM factory default". The NETWORK "private 4w" LED should be lit.

Press the Central Office FUNCTION key on the TAS 100 front panel. Press the value - key until the display indicates "LINE MODE:switched 2w". (The NETWORK station A "off hook" and "dial tone" LEDs should light up.)

The multimeter should indicate a range of +3.0 Vdc to +3.4 Vdc. Press the menu navigation ↓ key until the display indicates "LOOP CURRENT: A 32 mA B 32 mA".

Press the Measure function key on the front panel of the TAS 100 Series unit. Press the value + (or value -) key on the front panel of the TAS 100 Series unit until "SOURCE a rcv 2w" is displayed. The display should indicate a "LEVEL" of -18.0 ± 0.6 dBm.

Remove the connections at the TAS 100 Series unit rear terminal strip. Connect the TIMS transmit to the TAS 100 Series unit station A rear terminal strip, terminals 4 (R) and 5 (T). Connect the TIMS receive to the TAS 100 Series unit station B rear terminal strip, terminals 4 (R) and 5 (T).

With the TIMS transmitting the 1004 Hz tone at -10 dBm (600 ohms), the TIMS should report a received signal of $-18.0 \text{ dBm} \pm 0.6 \text{ dB}$ (600 ohms).

Press the value + (or value -) key on the front panel of the TAS 100 Series unit until "SOURCE b rcv 2w" is displayed. The display should indicate a "LEVEL" of -18.0 ± 0.6 dBm.

Use the value + (or value -) key to verify that DC voltage readings are correct for the four station A loop current settings indicated on the following chart:

CURRENT SETTINGS	DC VOLTAGE READINGS
120 mA	+11.4 to +12.6
64 mA	+6.0 to +6.8
16 mA	+1.3 to +1.9
8 mA	+0.5 to +1.1

Press the Submenu ↓ key until the display indicates “LOOP CURRENT POL: A pos B pos”. Press the value - key until the display indicates “LOOP CURRENT POL: A neg B pos”. The multimeter should indicate a range of -0.5 Vdc to -1.1 Vdc.

Turn off the TAS 100 AC power. Move the resistor and the multimeter leads to the station B rear terminals 5 (T) and 4 (R) [common to terminal 4 (R)].

Power on the TAS 100 unit. After the unit performs its SELF TEST/CALIBRATION, the display should indicate “LINE MODE:switched 2w”. The NETWORK “switched 2W” and NETWORK station B “off hook” and “dial tone” LEDs should be lit.

The multimeter should indicate a range of +3.0 Vdc to +3.4 Vdc. Press the menu navigation ↓ key until the display indicates “LOOP CURRENT: A→32 mA B→32 mA”.

Press the menu navigation → key until the cursor is at the “32 mA” position for station B. Use the value + (or value -) key to verify that DC voltage readings are correct for the four station B loop current settings indicated below:

CURRENT SETTINGS	DC VOLTAGE READINGS
120 mA	+11.4 to +12.6
64 mA	+6.0 to +6.8
16 mA	+1.3 to +1.9
8 mA	+0.5 to +1.1

Press the Submenu ↓ key until the display indicates “LOOP CURRENT POL: A neg B pos”. Press the menu navigation → key until the cursor is at the “pos” position for station B. Press the value - key until the display indicates “LOOP CURRENT POL: A neg B neg”. The multimeter should indicate a range of -0.5 Vdc to -1.1 Vdc.

Turn off the TAS 100 AC power. Remove the resistor, but leave the multimeter leads on the station B rear terminals 4 (R) and 5 (T) for the ring voltage verification.

Ring Voltage (and Operational) Verifications

NOTE: The multimeter leads should still be connected to the station B rear terminals and the TAS 100 AC power should be turned off.

Change the multimeter setting for AC voltage readings.

Connect an ordinary 2-wire dial pulse or touch-tone phone to the station A modular jack on the TAS 100 front panel.

Power on the TAS 100 unit. After the unit performs its SELF TEST/CALIBRATION, press the Recall FUNCTION key. Press the value + (or value -) key until "RECALL: CO+IMP factory default" is displayed. Press the Recall key again. The display should indicate "RECALLED FROM factory default". The NETWORK "private 4w" LED should be lit.

Press the Central Office FUNCTION key on the TAS 100 front panel. Press the value - key until the display indicates "LINE MODE:switched 2w".

Press the Submenu ↓ key until the display indicates "CADENCE RESOLUTION: 50 ms". Press the menu navigation ↓ key until the display indicates "RING: ON3 2000ms OFF3 4000ms".

Press the menu navigation → key until the cursor is at the "4" in the "4000" position.

Press the value - key until OFF3 is set for "0ms".

Press the Central Office FUNCTION key on the TAS 100 front panel. The display should indicate "LINE MODE:switched 2w". Press the menu navigation ↓ key until the display indicates "RINGING LEVEL 85 V FREQ 20.0 Hz".

Lift the headset at station A and verify that a dial tone is being received.

Dial pulse or touch-tone the number 555-9876. A ringback tone should be received at the headset; the NETWORK station B "Ringling" LED should light up; and the multimeter should indicate a range of 80.0 Vac to 90.0 Vac.

Use the value + (or value -) key to verify that AC voltage readings are correct for the following four ring voltage settings indicated:

RING VOLTAGE SETTINGS	AC VOLTAGE READINGS
100 Vac	94.0 to 106.0
70 Vac	66.0 to 74.0
50 Vac	47.0 to 53.0
20 Vac	18.5 to 21.5

Place the phone on-hook and turn off the TAS 100 AC power. Move the multimeter leads to the station A rear terminals 4 (R) and 5 (T).

Connect the telephone to the station B modular jack on the TAS 100 front panel. Power on the TAS 100 unit. After the unit performs its SELF TEST/CALIBRATION, the display should indicate "LINE MODE:switched 2w".

Press the menu navigation ↓ key until the display indicates "RINGING LEVEL 20 V FREQ 20.0 Hz".

Lift the headset at station B and verify that a dial tone is being received.

Dial pulse or touch-tone the number 555-0123. A ringback tone should be received at the headset; the NETWORK station A "Ringing" LED should light up; and the multimeter should indicate a range of 18.5 Vac to 21.5 Vac.

Use the value + (or value -) key to verify that AC voltage readings are correct for the four ring voltage settings indicated below:

RING VOLTAGE SETTINGS	AC VOLTAGE READINGS
50 Vac	47.0 to 53.0
70 Vac	66.0 to 74.0
85 Vac	80.0 to 90.0
100 Vac	94.0 to 106.0

Place the phone on-hook and turn off the TAS 100 AC power. Remove the multimeter leads on the station A rear terminals 4 (R) and 5 (T). Remove the phone from the front panel modular jack.

Operational Verification

Power on the TAS 100 unit. After the unit performs its SELF TEST/CALIBRATION, press the "Recall" FUNCTION key. Press the value + (or value -) key until "RECALL: CO+IMP factory default" is displayed. Press the "Recall" FUNCTION key again. The display should indicate "RECALLED FROM factory default". The NETWORK "private 4w" LED should be lit.

Press the "Central Office" FUNCTION key. Press the value - key until the display indicates "LINE MODE: switched 2w".

Connect 2-wire dial pulse or touch-tone phones to both station A and station B modular jacks on the TAS 100 front panel.

Lift the headset at station A and verify that a dial tone is being received.

Dial pulse or touch-tone the number 555-9876. Verify that the ringback tone is present at station A and the phone at station B is ringing.
Lift the headset at station B and verify the communication connection.

Place both phones on-hook.

Lift the headset at station B and verify that a dial tone is being received.

Dial pulse or touch-tone the number 555-0123. Verify that a ringback tone is present at station B and the phone at station A is ringing.

Lift the headset at station A and verify the communication connection.

Place both phones on-hook and disconnect them from the TAS 100 front panel.

NOTE: This concludes the TAS 100 verification procedure. If further assistance is required, contact the TAS Customer Service Department at (908) 544-8700.

This page intentionally left blank.