

**Spirent Communications**  
**TAS 240**  
**Voiceband Subscriber Loop Emulator**  
**Operations Manual**

## SAFETY SUMMARY

If the equipment is used in a manner not specified by the manufacturer the protection provided by the equipment may be impaired.

## SAFETY SYMBOLS

The following safety symbols are used throughout this manual and may be found on the instrument. Familiarize yourself with each symbol and its meaning before operating this instrument.



Instruction manual symbol. The product is marked with this symbol when it is necessary for the user to refer to the instruction manual to protect against damage to the instrument.



Frame terminal. A connection to the frame (chassis) of the equipment which normally includes all exposed metal structures.



Protective ground (earth) terminal. Used to identify any terminal which is intended for connection to an external protective conductor for protection against electrical shock in case of a fault, or to the terminal of a protective ground (earth) electrode.

### **Caution**

The caution sign denotes a hazard. It calls attention to an operating procedure, practice, condition or the like, which, if not correctly performed or adhered to, could result in damage to or destruction of part or all of the product or the user's data.



Indicates dangerous voltage (terminals fed from the interior by voltage exceeding 1000 volts must be so marked).



Alternating current (power line).

Spirent Communications  
541 Industrial Way West  
Eatontown, NJ 07724

Phone: (732) 544-8700

FAX: (732) 544-8347

This manual applies to the TAS 240 Voiceband Subscriber Loop Emulator

Page Version Part Number: 2700-2397, Version 2.10

Copyright © 2001, Spirent Communications of Eatontown, L.P.

Printed in the USA.

Information furnished by Spirent Communications is believed to be accurate and reliable. However, no responsibility is assumed by Spirent Communications for its use. Specifications are subject to change without notice.
--

## **ABOUT THIS MANUAL...**

---

The TAS 240 Voice Band Subscriber Loop Emulator Operations Manual contains the information required to use the emulator in the most effective manner. It is recommended that you familiarize yourself with this manual before attempting to use the TAS 240. This manual is organized as follows:

*Introduction* - prepares you to begin using the TAS 240. It provides a brief description, the features and applications, overviews of the front and rear panel, and installation procedures.

*Local Operation* -discusses the functions of the various displays, controls, jacks, and ports located on the front and rear panels.

*Remote Control Operation* - provides the necessary information to control the TAS 240 via RS-232C or GPIB (IEEE-488) interfaces. This section is essential reading for those who will be integrating a TAS 240 into a larger test system. Descriptions are also provided of the TAS 240 error codes possibly encountered during power-up or operation.

*Command Summary* - provides detailed descriptions of each remote command and its parameters. A summary of all the TAS 240 remote commands is included for quick reference.

*Error Codes* - list all the error codes that may be encountered during the operation of the TAS 240.

*Technical Specifications* - contains detailed system specifications, connector pinouts, and loop response graphs.

*Application Notes* - is reserved for application bulletins. An appendix addressing the TAS 240 Metering Pulses Option is included in this section. Application Note # 7 “The Effect of Metering Pulse Interference on Modems & Fax Machines” is also included.

This page intentionally left blank.

## **TABLE OF CONTENTS**

---

<b>1.0. Introduction.....</b>	<b>1-1</b>
1.1. TAS 240 Applications.....	1-3
1.2. TAS 240 Major Features.....	1-4
1.3. Front Panel Overview.....	1-5
1.4. Rear Panel Overview.....	1-6
1.5. Installation.....	1-8
1.5.1. Unpacking and Checkout.....	1-8
1.5.2. Initial Installation.....	1-9
1.5.3. Signal Interconnect with TAS Series II Telephone Network Emulators.....	1-10
1.5.4. Signal Interconnect with TAS 100 Series Telephone Network Emulators.....	1-12
1.5.5. TAS 240L Signal Interconnect with Series II T.N.E. ....	1-14
1.5.6. TAS 240L Interconnect with 100 Series T.N.E. ....	1-15
1.5.7. Control Interconnect for TASKIT Operation.....	1-17
1.5.8. Control Interconnect for Non-TASKIT Operation.....	1-18
1.6. System Description.....	1-19
1.6.1. Description of Main Loop.....	1-21
1.6.2. Description of Tracking Loop.....	1-22
1.6.3. Description of Balance Network.....	1-23
1.6.4. Description of Measurement Feature.....	1-24
1.7. Description of Impairments.....	1-25
1.7.1. White Noise.....	1-25
1.7.2. Impulse Noise.....	1-26
1.7.3. Multi-Frequency Interference.....	1-27
1.8. Feature Release History.....	1-25
<b>2.0. Local Operation.....</b>	<b>2-1</b>
2.1. High Level Menu Structure.....	2-2

2.2. Front Panel Operation.....	2-3
2.2.1. Main Menu .....	2-3
2.2.2. Select Loop A .....	2-4
2.2.3. Auxiliary Parameters.....	2-6
<b>3.0. Remote Control Operation.....</b>	<b>3-1</b>
3.1. Configuring the TAS 240 for Remote Control .....	3-2
3.2. Sending Commands to the TAS 240.....	3-3
3.3. Remote Control Protocols .....	3-6
3.3.1. RS-232C CR/LF Protocol .....	3-6
3.3.2. ACK/NAK Protocol.....	3-7
3.3.3. GPIB Protocol.....	3-10
<b>4.0. Command Summary.....</b>	<b>4-1</b>
4.1. TAS 240 Remote Commands Reference.....	4-1
4.2. TAS 240 Configuration (CNFG) .....	4-3
4.3. TAS 240 Loop A (LOOPA).....	4-6
4.4. TAS 240 Loop B (LOOPB).....	4-9
4.5. TAS 240 Measure (MEAS).....	4-12
4.6. Metering Pulse (METER) (Optional) .....	4-13
4.7. Impairments Generator (IMP) (Optional).....	4-15
<b>5.0. Error Codes.....</b>	<b>5-1</b>
<b>6.0. Technical Specifications.....</b>	<b>6-1</b>
6.1. General .....	6-1
6.2. Wire Simulation .....	6-2
6.3. Test Interfaces .....	6-3
6.4. Remote Control Interfaces .....	6-5
6.5. Metering Pulse Interface .....	6-7
6.6. Impairments Interface .....	6-7
6.7. Crosstalk Between Loops .....	6-7

6.8. ETSI Balance Networks .....	6-8
6.9. Pad.....	6-9
6.10. Loop Definitions .....	6-10
6.11. Insertion Loss Graphs.....	6-11
6.12. Fuse Replacement Procedure .....	6-16
6.13. Impairments.....	6-17
<b>TAS Application Note #7: The Effect of Metering Pulse Interference on Modem and Fax Machines.....</b>	<b>Pg 1</b>
Metering Pulse Testing Requirements .....	Pg 1
Test Bench Set up .....	Pg 3
Example: Testing the German Conditions .....	Pg 5
<b>Appendix A: TAS 240 Metering Pulses (Option).....</b>	<b>A-1</b>
A.1. Introduction.....	A-1
A.1.1. System Description .....	A-2
A.2. Operating the Metering Pulse Generator.....	A-4
A.2.1. Calibration .....	A-5
A.2.2. Source Impedance .....	A-6
A.3. Setup .....	A-8
A.4. Local Operation .....	A-11
A.5. Remote Commands.....	A-14
A.6. Metering Pulse Technical Specifications .....	A-17

This page intentionally left blank.



## 1.0. INTRODUCTION

---

The TAS 240 Voiceband Subscriber Loop Emulator (VSLE) is a general purpose loop emulator for voiceband applications. The VSLE provides simulation of up to four (4) loops in a single enclosure. The VSLE has been designed specifically to provide the loop emulation required for testing high-speed voiceband modems per the specifications provided by (or currently proposed by) the EIA/TIA TR30.3 sub-committee, ETSI, and the CCITT.

The VSLE simulates four loops in order to completely emulate the network which interconnects two modems. The four loops are allocated to the following:

- One "main" loop between the Telephone Network Emulator station A, and modem "A"
- One "main" loop between the Telephone Network Emulator station B, and modem "B"
- One "tracking" loop to provide the balance network for the station A hybrid
- One "tracking" loop to provide the balance network for the station B hybrid

The second pair of loops, "main" loop for station B and its associated tracking loop, is an optional feature of the VSLE.

The VSLE also emulates impairments such as noise, impulse hits and multiple frequency interference, which are present on the local loops. These impairments are specified by the developing TIA PN 3857 test specification. Impairments are an optional feature of the VSLE.

In addition to loop simulation and impairments the VSLE simulates metering pulses which are present on the local loops of several European countries, and are specified by the ETSI test specifications. Metering pulses are also an optional feature of the VSLE.

The available models and configuration of options for the TAS 240 VSLE are as follows:

- 240A VSLE with four loops and metering pulses
- 240 VSLE with four loops
- 240L VSLE with two loops  
(Loop A with A tracking loop).
- 240M VSLE with metering pulses and no loops
- 240I VSLE with four loops and impairments

This manual describes the 240A system unless otherwise indicated.

The TAS 240 Voiceband Subscriber Loop Emulator (VSLE) is designed to emulate the local loop conditions specified by the EIA/TIA TR30.3, ETSI, and ITU (CCITT) organizations. In addition the TAS 240 will emulate user defined loops. The TAS 240 emulates up to two sets of loops where each set consists of a "main" loop and its associated "tracking" loop. The main loop is used to emulate the Station A or Station B local loop, while the tracking loop is used primarily as the balance network for balancing the Station A or Station B hybrid. Loop B is independent of Loop A. However, each tracking loop is always identical to its main loop. For test configurations which do not require the balance network to be identical to the loop, the tracking loop may be used as a primary loop.

The TAS 240 VSLE may be equipped with the optional impairment generator when initially purchased. This option allows the user to control noise, impulse hits, and multiple frequency interference individually. Each of these impairments can also be turned on simultaneously with any of the other impairment operating. Loop impairments are necessary to meet the testing requirements of the developing TIA PN3857 testing standard.

The TAS 240 VSLE may be equipped with the optional metering pulse generator when initially purchased. This option allows the user to program the frequency, level, and cadence of the metering (or billing) pulse signal injected onto the specified main loop. Metering pulses are required to meet the ETSI testing requirements of several European countries.

The TAS 240 is intended to be integrated into a complete modem test system under control of TASKIT. The components of the overall test system include a TAS 1022 Gemini Dual Terminal Emulator, and either the TAS 100 Series or TAS Series II Telephone Network Emulator. Alternatively, the TAS 240 may also be used as a standalone product, controlled manually via the front panel, or remotely via RS-232 or IEEE-488.

## 1.1. TAS 240 Applications

The TAS 240 is primarily intended to be used to test and evaluate high speed modems such as V.32, V.32bis, and V.34 types. The TAS 240 will also serve in any application requiring emulation of voiceband local loops including:

- Modem Evaluation and Testing
- Fax Evaluation and Testing
- Communications Software Evaluation
- Communications Terminal Testing

Figure 1-1 shows a basic setup for testing high speed modems.

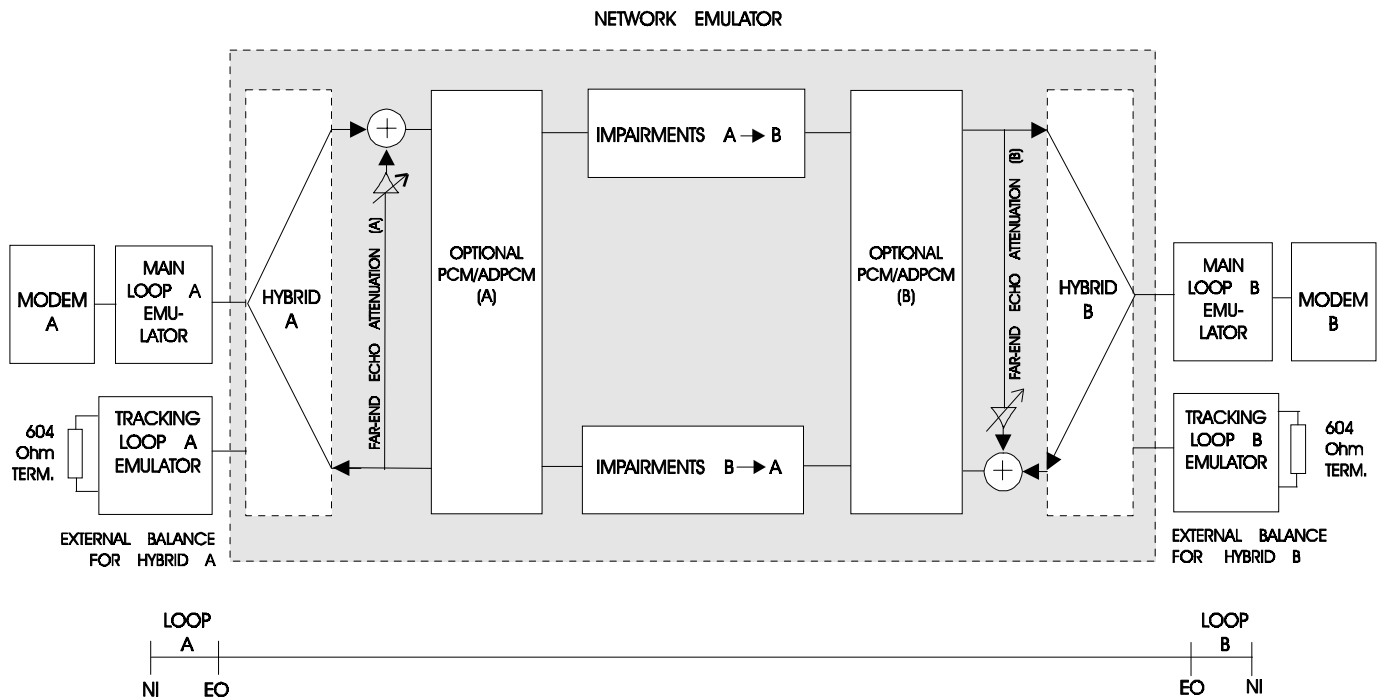

Figure 1-1. Basic VSLE Set-Up

## **1.2. TAS 240 Major Features**

- Emulation of all EIA local loops
- Emulation of both ETSI local loops
- User programmable loops
- Emulation of two main loops and two tracking loops in one small enclosure
- Verification of loop loss at user specified frequencies
- Provides metering pulses (optional)
- Provides impairments (optional)

### 1.3. Front Panel Overview

Figure 1-2 shows the TAS 240 front panel. The panel contains a two line LCD display and four control keys. They provide the following front panel control:

- The two line display provides instructions and parameter settings for all functions of the emulator.
- The four control keys are used to navigate through the various displays (ENTER and ESC keys) and to change parameter values (+ and - keys).

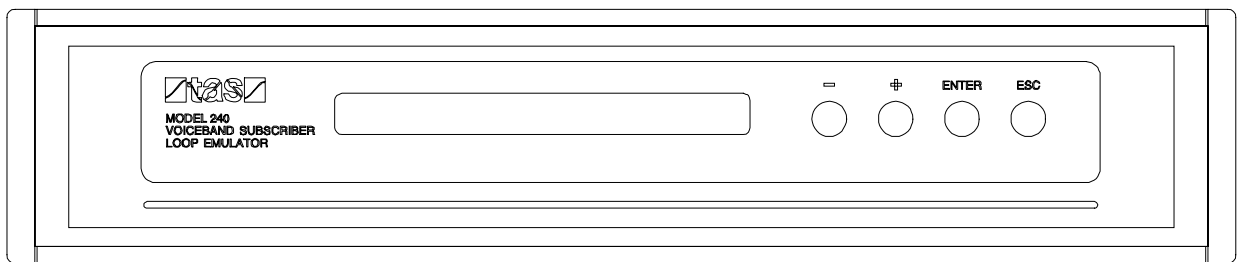
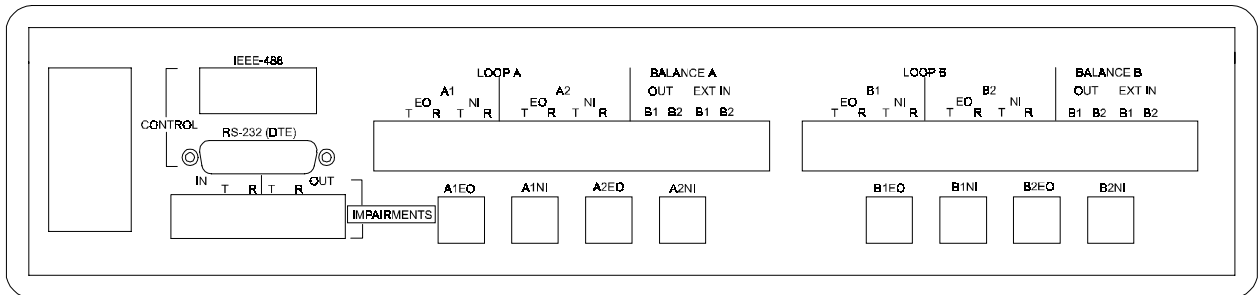

Figure 1-2. TAS 240 Front Panel

## 1.4. Rear Panel Overview

Figure 1-3 shows the TAS 240 rear panel. The following information provides a brief description of each rear panel feature.



**Figure 1-3. TAS 240 Rear Panel**

- The AC switch/receptacle assembly contains the ON/OFF switch, the AC power connector, and the fuse.
- The CONTROL IEEE-488 port allows an external IEEE-488 controller to control the TAS 240.
- The CONTROL RS-232 (DTE) port allows an external computer to control the TAS 240.
- The METERING PULSE terminal strip allows access to the metering pulse generator.
- The IMPAIRMENTS terminal strip allows access to the impairments generator.
- The LOOP A - A1 main loop terminal strip provides access to both ends of the loop A main loop, the End Office end (EO) and the Network Interface end (NI).
- The LOOP A - A2 tracking loop terminal strip provides access to both ends of the loop A tracking loop, the End Office end (EO) and the Network Interface end (NI).
- The BALANCE A - OUT terminal strip provides access to the user selected balance network for loop A.
- BALANCE A - EXT IN terminal strip provides access for the user to supply a custom termination to the balance network.

- The modular jack A1EO is in parallel with the LOOP A - A1 EO terminal strip.
- The modular jack A1NI is in parallel with the LOOP A - A1 NI terminal strip.
- The modular jack A2EO is in parallel with the LOOP A - A2 EO terminal strip.
- The modular jack A2NI is in parallel with the LOOP A - A2 NI terminal strip.
- The LOOP B - B1 main loop terminal strip provides access to both ends of the loop B main loop, the End Office end (EO) and the Network Interface end (NI).
- The LOOP B - B2 tracking loop terminal strip provides access to both ends of the loop B tracking loop, the End Office end (EO) and the Network Interface end (NI).
- The BALANCE B - OUT terminal strip provides access to the user selected balance network for loop B.
- BALANCE B - EXT IN terminal strip provides access for the user to supply a custom termination to the balance network.
- The modular jack B1EO is in parallel with the LOOP B - B1 EO terminal strip.
- The modular jack B1NI is in parallel with the LOOP B - B1 NI terminal strip.
- The modular jack B2EO is in parallel with the LOOP B - B2 EO terminal strip.
- The modular jack B2NI is in parallel with the LOOP B - B2 NI terminal strip.

## 1.5. Installation

Prior to installing the TAS 240 for the first time the system must be unpacked and all components verified.

### 1.5.1. Unpacking and Checkout

To prepare the TAS 240 for initial operation, perform the following steps:

1. Unpack the TAS 240 shipping carton. The carton should contain the following items:
  - TAS 240 Voiceband Subscriber Loop Emulator
  - Operations Manual
  - AC power cord
  - Two RJ-45 voice cables
  - One 4-wire spade-lugged cable

**NOTE:** Please make sure that all parts of your TAS 240 Voiceband Subscriber Loop Emulator are present. Save the shipping carton and packing materials until you have completed the system installation and initial check. If you must return any equipment, please use the original packing material.

2. Check each item for physical damage. If any item appears damaged, please immediately contact the TAS customer service department.
3. Connect the TAS 240 to a proper AC power receptacle. Note that the TAS 240 has a "Universal" input power supply and does not require any additional configuration to be used with any voltage between 85V and 260V.
4. Turn on the TAS 240.
5. An automatic self-calibration and diagnostics procedure should be performed immediately. During this procedure, the TAS 240 verifies its loop sections and measurement circuitry.

**NOTE:** If the power-up procedure encounters a failure during its self-test/calibration operation, note the error code that is displayed on the front panel. Be prepared to give this error code to your local representative or to TAS when you call for service. Contact the TAS Customer Service Department immediately.



## 1.5.2. Initial Installation

The installation of the TAS 240 consists of two parts, the signal interconnect, and the control interconnect. The signal interconnect is different depending on whether the TAS 240 is installed with the TAS 100 Series or Series II Network Emulators. Figure 1-4 shows the overall implementation of the test set-up.

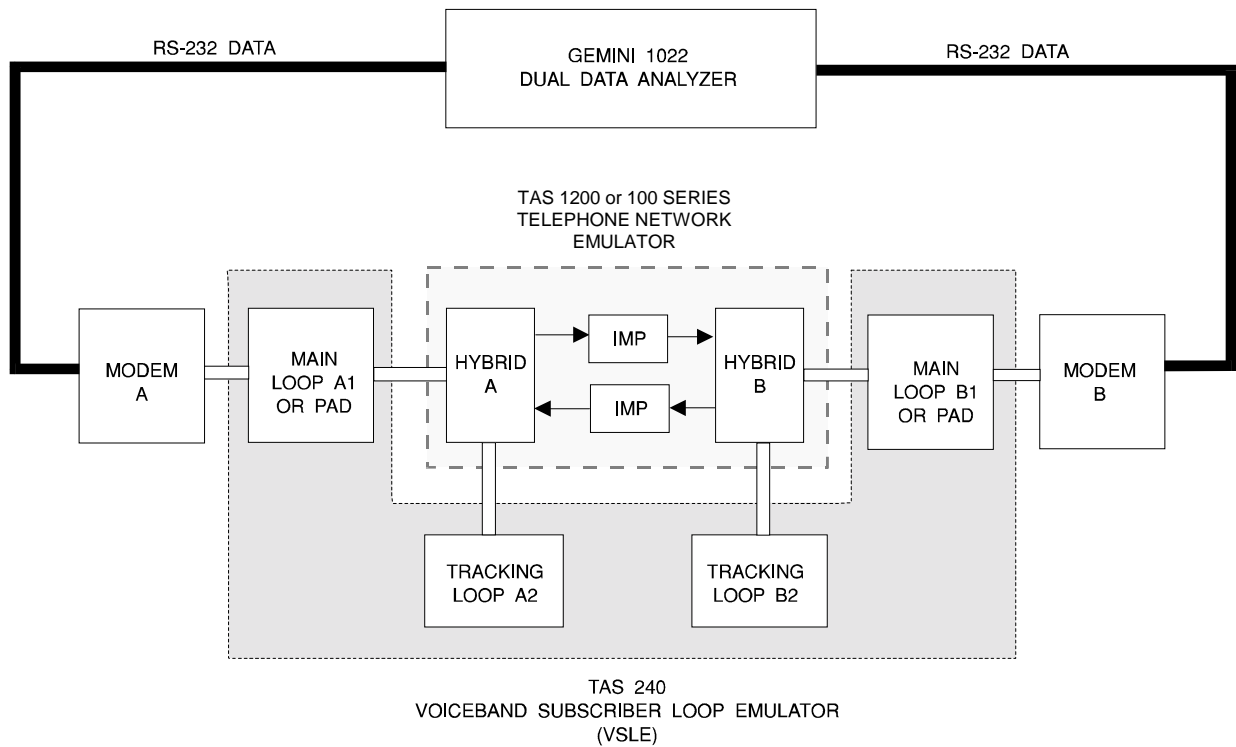

**Figure 1-4. Implementation of the VSLE Test Set-Up**

### 1.5.3. Signal Interconnect with TAS Series II Telephone Network Emulators

Figure 1-5 illustrates a typical signal interconnection between a four loop TAS 240 and a Series II Telephone Network Emulator. The control interconnect will depend on both the type of control (RS-232 or IEEE-488), and the controlling software (TASKIT or user provided). The installation procedure which follows assumes a fully configured TAS 240 (two sets of loops).

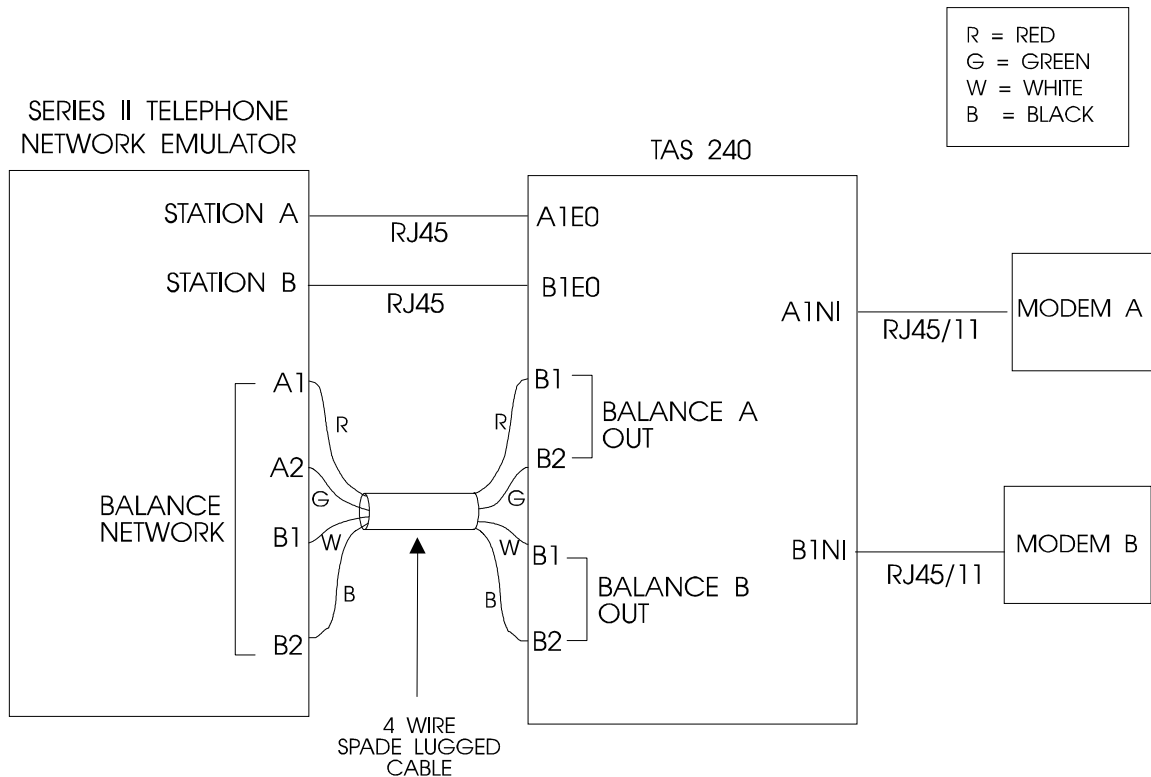

**Figure 1-5. Typical Signal Interconnection Between a Four Loop TAS 240 and a Series II Telephone Network Emulator**

The following connections must be made when the TAS 240 is installed with a Series II Network Emulator:

1. Connect TAS 240 A1E0 to Network Emulator Station A (using RJ-45 cable).
2. Connect TAS 240 A1NI to Modem A (using RJ-45 or RJ-11 cable).
3. Connect TAS 240 B1E0 to Network Emulator Station B (using RJ-45 cable).
4. Connect TAS 240 B1NI to Modem B (using RJ-45 or RJ-11 cable).

The connections in steps 5-8 are made with the 4-wire spade-lugged cable provided with the TAS 240 VSLE.

5. Connect TAS 240 BALANCE A - OUT B1 to Network Emulator Balance Network A1.
6. Connect TAS 240 BALANCE A - OUT B2 to Network Emulator Balance Network A2.
7. Connect TAS 240 BALANCE B - OUT B1 to Network Emulator Balance Network B1.
8. Connect TAS 240 BALANCE B - OUT B2 to Network Emulator Balance Network B2.

Steps 1-4 insert the TAS 240 Main Loops A and B between the Series II Network Emulator and Modems A & B.

Steps 5-8 connect the A & B Tracking Loops to the hybrid balance ports of the Series II Network Emulator.

**NOTE:** For most typical installations there is no direct connection to either the A2 or B2 (tracking loops A & B) ports of the TAS 240. The tracking loops are connected to the balance networks via the BALANCE - OUT ports of the TAS 240.

### 1.5.4. Signal Interconnect with TAS 100 Series Telephone Network Emulators

Figure 1-6 illustrates a typical signal interconnection between a four loop TAS 240 and a 100 Series Telephone Network Emulator, models 150, 151, 152, 181, 182. The control interconnect will depend on both the type of control (RS-232 or IEEE-488), and the controlling software (TASKIT or user provided). The installation procedure which follows assumes a fully configured TAS 240 (two sets of loops).

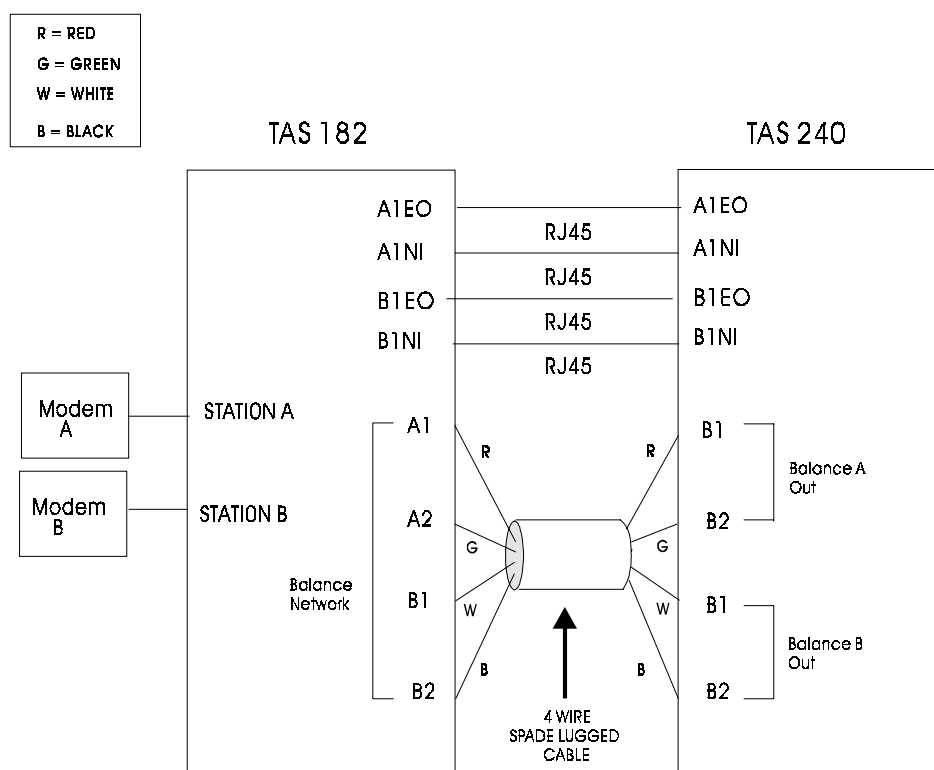

**Figure 1-6. Typical Signal Interconnection Between a Four Loop TAS 240 and a 100 Series Telephone Network Emulator**

The following connections must be made when the TAS 240 is installed with a 100 Series Network Emulator:

1. Connect TAS 240 A1EO to Network Emulator Station A1EO (using RJ-45 cable).
2. Connect TAS 240 A1NI to Network Emulator Station A1NI (using RJ-45 cable).

3. Connect TAS 240 B1EO to Network Emulator Station B1EO (using RJ-45 cable).
4. Connect TAS 240 B1NI to Network Emulator Station B1NI (using RJ-45 cable).
5. Connect Network Emulator Station A to Modem A (using RJ-45 or RJ-11 cable).
6. Connect Network Emulator Station B to Modem B (using RJ-45 or RJ-11 cable).

The connections in steps 7-10 are made with the 4-wire spade-lugged cable provided with the TAS 240 VSLE.

7. Connect TAS 240 BALANCE A - OUT B1 to Network Emulator Balance Network A1.
8. Connect TAS 240 BALANCE A - OUT B2 to Network Emulator Balance Network A2.
9. Connect TAS 240 BALANCE B - OUT B1 to Network Emulator Balance Network B1.
10. Connect TAS 240 BALANCE B - OUT B2 to Network Emulator Balance Network B2.

Steps 1-6 insert the TAS 240 Main Loops A and B between the Series II Network Emulator and Modems A & B.

Steps 7-10 connect the A & B Tracking Loops to the hybrid balance ports of the 100 Series Network Emulator.

<p><b>NOTE:</b> For most typical installations there is no direct connection to either the A2 or B2 (tracking loops A &amp; B) ports of the TAS 240. The tracking loops are connected to the balance networks via the BALANCE - OUT ports of the TAS 240.</p>
---

### 1.5.5. TAS 240L Signal Interconnect with Series II T.N.E.

Figure 1-7 illustrates a signal interconnection between a TAS 240L (two loops) and a Series II Telephone Network Emulator.

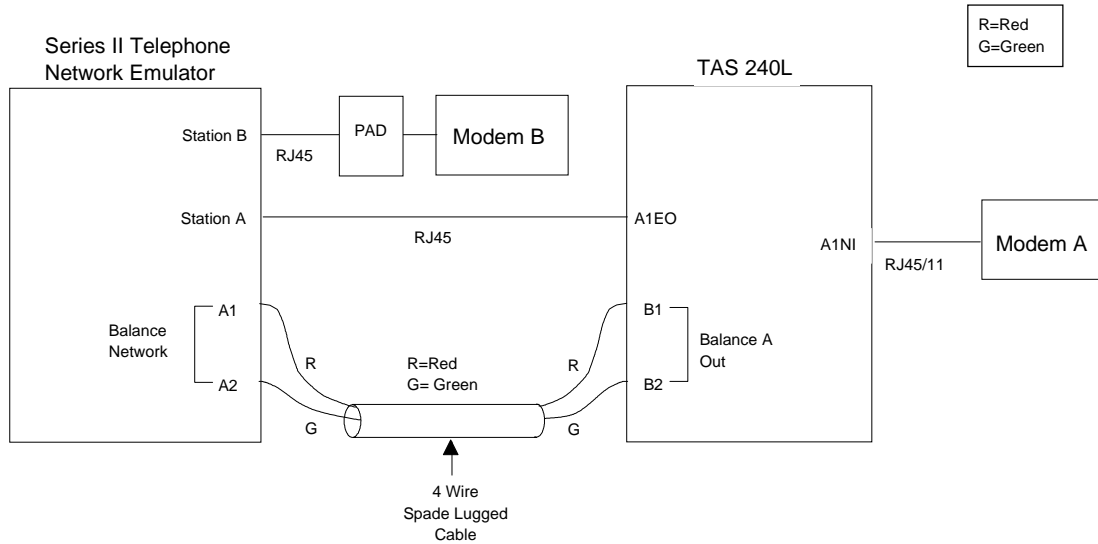

**Figure 1-7. Typical Signal Interconnection with TAS 240L and Series II Telephone Network Emulator**

**NOTE:** The Pad function may be provided either with a TAS-LIA (Line Interface Adaptor) or a user supplied external circuit.

The following connections must be made when the TAS 240L is installed with a Series II Network Emulator:

1. Connect TAS 240L A1E0 to Network Emulator Station A (using RJ-45 cable).
2. Connect TAS 240L A1NI to Modem A (using a RJ-45 or RJ-11 cable).
3. Connect Telephone Network Emulator Station B to the Pad. (using an RJ-11 cable).
4. Connect the Pad to Modem B (using an RJ-45 cable).

The connections in steps 5-6 are made with a 4-wire spade-lugged cable.

5. Connect TAS 240 BALANCE A-OUT B1 to Network Emulator Balance Network A1.
6. Connect TAS 240 BALANCE A-OUT B2 to Network Emulator Balance Network A2.

### 1.5.6. TAS 240L Signal Interconnect with 100 Series T.N.E.

Figure 1-8 illustrates a signal interconnection between a TAS 240L (two loops) and a 100 Series Telephone Network Emulator, models 150, 151, 152, 181, and 182.

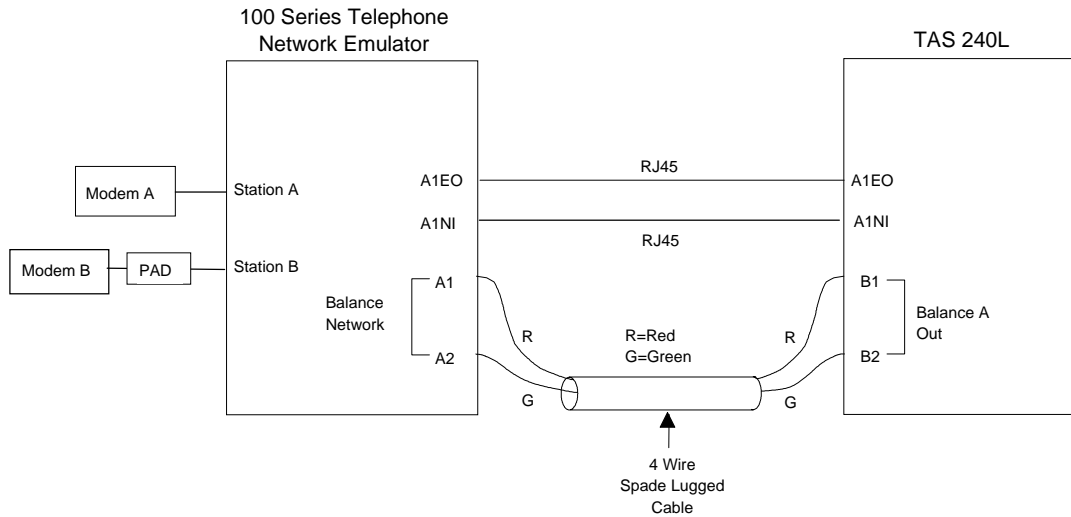

**Figure 1-8. Typical Signal Interconnection with TAS 240L and 100 Series Telephone Network Emulator**

**NOTE:** The Pad function may be provided either with a TAS-LIA (Line Interface Adaptor) or a user supplied external circuit.

The following connections must be made when the TAS 240L is installed with a 100 Series Network Emulator:

1. Connect TAS 240L A1E0 to Network Emulator Station A1E0 (using an RJ-45 cable).
2. Connect TAS 240L A1NI to Network Emulator Station A1NI (using an RJ-45 cable).
3. Connect Network Emulator Station A to Modem A (using an RJ-45 or RJ-11 cable).
4. Connect Network Emulator Station B to the Pad (using an RJ-45 or RJ-11 cable).
5. Connect the Pad to Modem B (using an RJ-45 cable).

The connections in steps 6-7 are made with a 4-wire spade-lugged cable.

6. Connect TAS 240 BALANCE A-OUT B1 to Network Emulator Balance Network A1.
7. Connect TAS 240 BALANCE A-OUT B2 to Network Emulator Balance Network A2.

For installation of a 240M (Metering Pulses only) refer to Appendix A.

**NOTE:** Before using a 100 Series Telephone Network Emulator, models 150, 151, 152, 181, 182, with any TAS 240 Loop Emulator, verify the Loop A In/Out and Loop B In/Out switches are in the “In” position.

For most typical installations there is no direct connection to either the A2 or B2 (tracking loops A & B) ports of the TAS 240. The tracking loops are connected to the balance networks via the BALANCE - OUT ports of the TAS 240.



### 1.5.7. Control Interconnect for TASKIT Operation

When the TAS 240 is installed into a test system which is controlled by TASKIT the TAS 240 is connected to the IEEE-488 port of the TAS 1022 Gemini along with the Network Emulator. The TAS 240 must be configured from the front panel for IEEE-488 remote control with an address of 4.

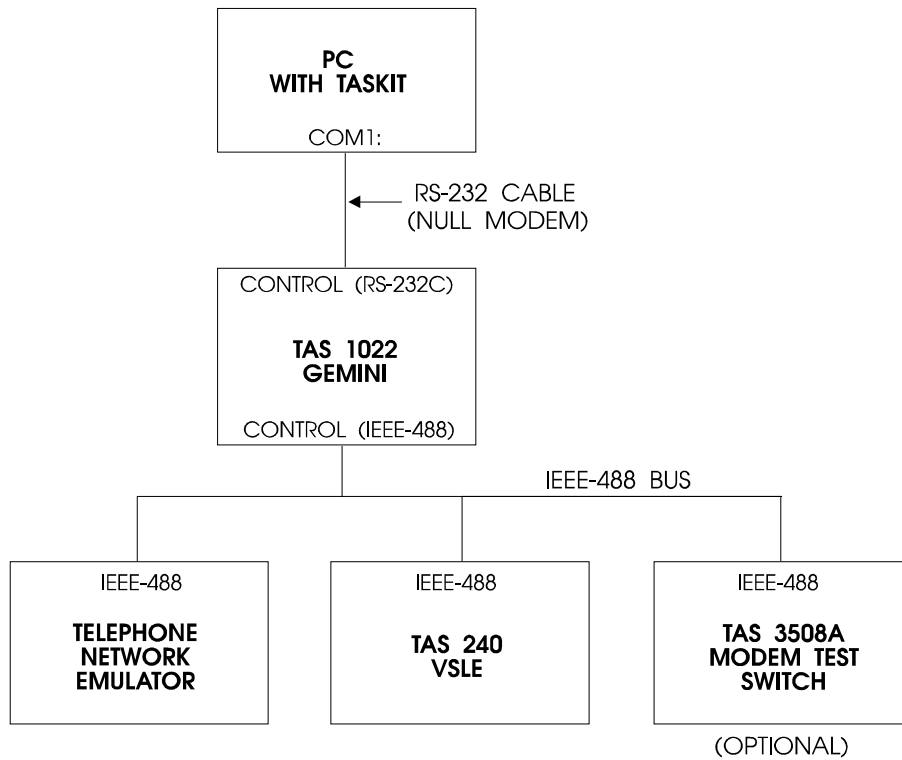

Figure 1-9. Typical VSLE Control Interconnection for Operation with TASKIT

### **1.5.8. Control Interconnect for Non-TASKIT Operation**

The TAS 240 may be controlled remotely via either RS-232 or IEEE-488. The control mode is selected from the front panel under the CONFIGURATION menu.

When controlled via RS-232 in either the ACK/NAK or CRLF protocol the RS-232 CONTROL port on the rear of the TAS 240 is connected to the controller RS-232 port. The TAS 240 RS-232 CONTROL port is configured as a DTE (Data Terminal Equipment) device. Therefore, if the controller is also a DTE (such as a PC "COM" port) a null modem must be used to connect the controller to the TAS 240.

When controlled via IEEE-488 the TAS 240 will always expect commands to it terminated with EOI active during the last receive character. Similarly any response from the TAS 240 will terminate with EOI active during the last transmitted character.

For more information regarding remote control see the Remote Control Operation section of this manual.

## 1.6. System Description

The TAS 240 Voiceband Subscriber Loop Emulator (VSLE) provides two-wire loop emulation and hybrid balance network emulation for up to two stations. The primary loop emulation is provided by the main loop (loop A1 or B1) of the TAS 240. This loop is placed between the Telephone Network Emulator and the modem to connect to that station of the emulator. The hybrid balance emulation is available to provide the hybrid of the Telephone Network Emulator the best possible match to the impedance of the primary loop. The match between these two impedances will determine the amount of residual echo present at the interface of the Network Emulator, the better the match the less the echo. The hybrid balance network emulation may be any one of four choices, the tracking loop (A2 or B2), ETSI RC1, ETSI RC2, or a user provided external network.

The differences between the main and tracking loops are:

- Only the tracking loop may be terminated internal to the TAS 240 in 600 ohms.
- The tracking loop may be switched to the BALANCE - OUT port of the TAS 240.
- Optional metering pulses or impairments may only be injected onto the main loops.

The two ends of the loops are designated EO (End Office) which connects to the Network Emulator, and the NI (Network Interface) which connect to the modem (or termination network in the case of the tracking loop).

The balance network should always be connected to Network Emulator via the BALANCE OUT port of the VSLE. The balance network is selected from the following choices:

- Tracking loop
- ETSI RC1 or RC2
- User supplied network connected to the BALANCE - EXT IN port

When the selected balance network is the tracking loop, the user will not have access to the EO end of the tracking loop at the A2EO (or B2EO) port of the VSLE. Similarly if the tracking loop is terminated internally (600 ohms) the NI end of the tracking loop will not be present at the A2NI (or B2NI) port of the VSLE.

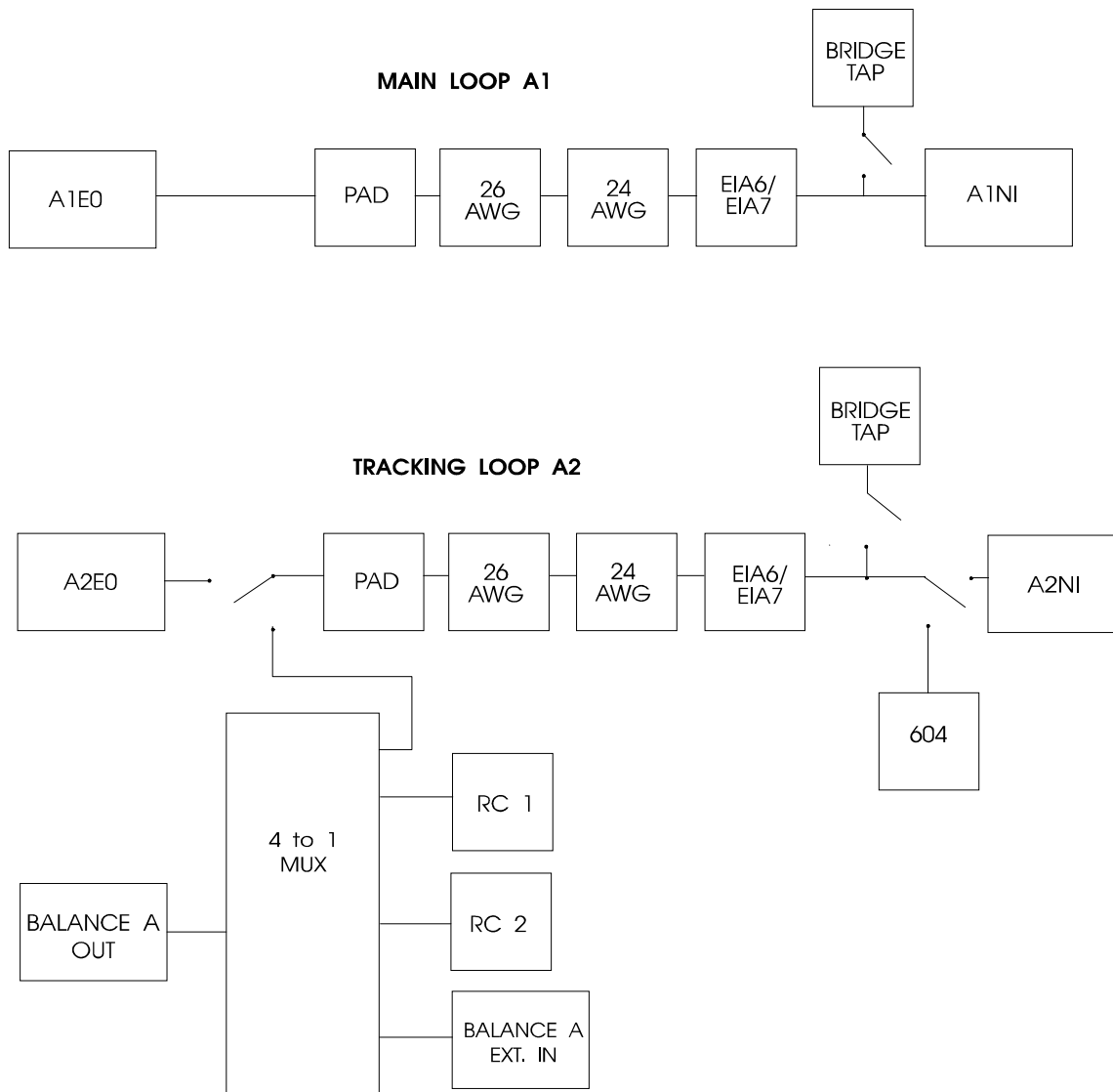

Figure 1-10. TAS 240 Functional Block Diagram

### 1.6.1. Description of Main Loop

The main loop(s) are accessed via the A1NI/A1EO (B1NI/B1EO) ports or terminal strips of the TAS 240 VSLE. Each main loop consists of a number of wire simulation modules which are switched onto the signal path to form the specific loop being emulated. The specific order of these modules from the EO end to the loop to the NI end is:

- Pad - 6.1 dB attenuation pad
- 26 AWG - 26 gauge wire adjustable from 0 to 15 Kft
- 24 AWG - 24 gauge wire adjustable from 0 to 15 Kft
- EIA6/7 - Combined wire gauges configured to emulate the EIA loops number 6 or 7
- Bridged Tap(s) - 1.5 Kft of 26 AWG wire configured to be open ended bridged tap(s)

**NOTE:** Each series module listed above may either be inserted into the signal path of the loop or bypassed, while the bridged tap(s) is either connected across the pair or removed from the loop by not connecting.

## 1.6.2. Description of Tracking Loop

The tracking loop(s) are accessed via the A2NI/A2EO (B2NI/B2EO) ports or terminal strips of the TAS 240 VSLE. Each tracking loop of the TAS 240 VSLE consists of the same configuration of wire modules as the main loop(s). The configuration of the tracking loop is always identical to that of the main loop. The tracking loop does add the ability to terminate the loop at the NI end with an internal 604 Ohm resistor. Again the specific order of the modules from the EO end to the tracking loop to the NI end is:

- Pad - 6.1 dB attenuation pad
- 26 AWG - 26 gauge wire adjustable from 0 to 15 Kft
- 24 AWG - 24 gauge wire adjustable from 0 to 15 Kft
- EIA6/7 - Combined wire gauges configured to emulate the EIA loops number 6 or 7
- Bridge Tap - 1.5 Kft of 26 AWG wire configured to be open ended bridged tap(s)

When a tracking loop is terminated by the 604 Ohm resistor internal to the VSLE the NI end of that tracking loop is no longer present at the A2NI (or B2NI) port or terminal strip of the VSLE. Similarly when a tracking loop is selected as the balance network, the EO end of that tracking loop is no longer present at the A2EO (or B2EO) port or terminal strip. See the description below of the balance network for more information.

### 1.6.3. Description of Balance Network

The balance network for each loop of the TAS 240 VSLE is accessed via the BALANCE OUT and BALANCE EXT IN terminal strips on the rear of the VSLE. The BALANCE OUT connector connects to the hybrid balance port of the Telephone Network Emulator . The BALANCE EXT IN connector is only used if a custom balance network is to be used. The selections for the balance network are:

- Tracking loop - The EO end of the tracking loop (A2 or B2) is switched from the EO port (and terminal strip) to the BALANCE OUT connector
- ETSI RC1 circuit, as per ETSI Net.20
- ETSI RC2 circuit, as per ETSI Net.20
- External - The BALANCE EXT IN terminals are switched to the BALANCE OUT terminals of the VSLE. This connects any user balance network (connected to the BALANCE EXT IN terminals) to the BALANCE OUT terminals

#### **1.6.4. Description of Measurement Feature**

The measurement feature in the VSLE allows the user to determine the insertion loss of the currently implemented loop. From the front panel the measurement is taken at 804 Hz, and 1004 Hz. From the remote interface, the user specifies the frequency at which the measurement is performed. The user also specifies in which direction (EO to NI or NI to EO) the measurement is to be made. The loop path through the VSLE is broken momentarily while a measurement is performed on that loop.

The measurement function is also used in conjunction with the metering pulses generator for calibration purposes (see metering pulses description).



## 1.7 Description of the Impairment Option

In addition to wire simulation, the TAS 240 Impairment Option is capable of generating a variety of impairments to inject on the wire. These impairments not only facilitate EIA/TIA developing specification PN3857 compliance testing, but also are sufficiently flexible for use in a development environment for other analog voiceband applications. The impairments include:

- White Noise
- Impulse Noise IEEE-743
- Multi Frequency Interference

The impairments are additive and can be coupled onto the loop at either the EO or NI side. The impairments can be applied to either Loop A or Loop B, if the system contains a second Wire Board. Each of the impairments is controlled individually and can be turned on separately or together with each other. All of the impairments are controlled through the remote interface. The impairments are not available via the front panel. TASKIT/240 provides a convenient method for controlling the impairment settings. A complete description of each impairment is contained in the following sections.

### 1.7.1 White Noise

White noise is defined as any unwanted transfer of energy from one or more working circuits into the circuit of interest. Since the energy transferred typically appears as random noise with a specific frequency distribution, this condition is best simulated by a Gaussian white noise source with a frequency spectrum shaped to mimic the source and the effects of the coupling mechanism from the interfering circuit or circuits. The levels are then measured through various filter types to indicate the noise energy present over a specified bandwidth. The TAS 240 provides the most common noise spectrum: a flat bandwidth noise illustrated in Figure 1-11.

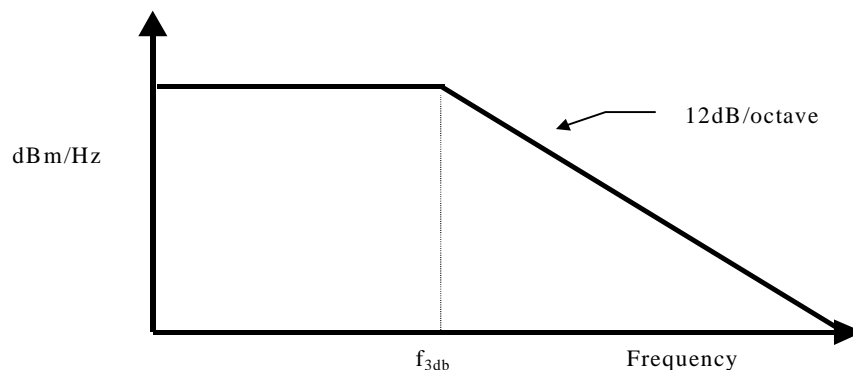

Figure 1-11. TAS 240 Flat Noise Spectrum

The impairment generator of the TAS 240 uses a pseudo-random Gaussian white noise source to generate a noise spectrum, which is flat from DC to 5KHz frequency. The roll-off rate after this point is 12 dB per octave.

### Programming Parameters

There are two parameters for programming Noise: ENABLE or LEVEL. To change a parameter, use the appropriate remote command under the IMP command group. Below is the description for setting parameters in each of these fields.

The ENABLE parameter has only two selections: ON or OFF. When the impairment is on and the source is allocated, the impairment is then coupled to the pair and station selected during allocation.

The LEVEL parameter set the power level of the Noise. The power is specified in units of dBrn. The TAS 240 noise level range is 15 dBrn to 50 dBrn in 0.1dB steps.

### 1.7.2 Impulse Noise

Impulse noise is unwanted spurious noise. Impulse noise can have a detrimental effect on data signals due the large peak values of the waveform. Impulse noise in the voiceband has a “popping” or crackling sound; higher frequency impulse noise may not be audible.

Although there are no defined impulse impairments for the analog loop, the TAS 240 provides voiceband impulses in accordance with the IEEE-743-1984 specification. The IEEE standard impulse noise is shown in Figure 1-12. The spectral energy of this signal is primarily concentrated in the frequency range below 3500 Hz.

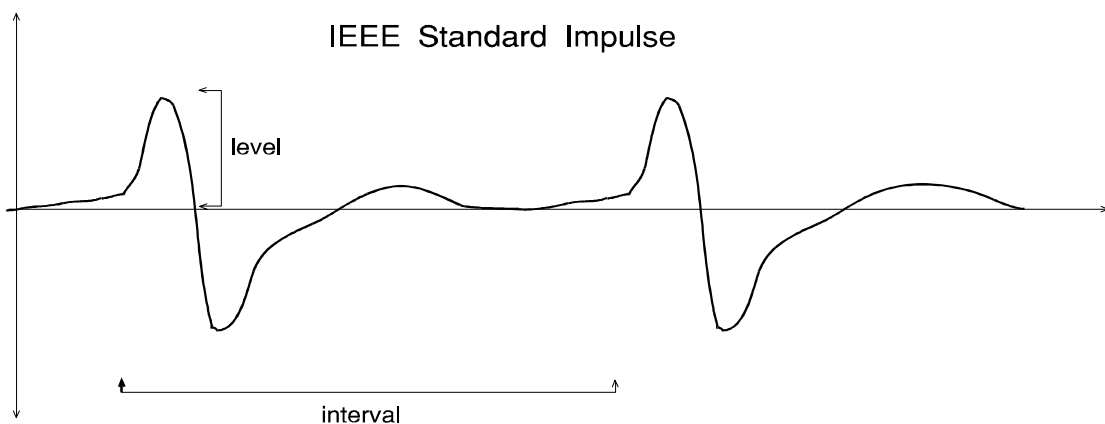

Figure 1-12. IEEE Standard Impulse

### **Programming Parameters**

There are three parameters for programming Impulse Noise: ENABLE, LEVEL or INTERVAL. To change a parameter, use the appropriate remote command under the IMP command group. Below is the description for setting parameters in each of these fields.

The ENABLE parameter has only two selections: ON or OFF. When the impairment is on and the source is allocated, the impairment is then coupled to the pair and station selected during allocation.

The LEVEL parameter sets the peak level or threshold reached by the impulse as measured after the impulse has been passed through a C-notch filter. The TAS 240 impulse level range is 30 dBrnC to 70 dBrnC in 0.1dB steps.

The INTERVAL parameter sets the arrival time between adjacent periodic impulses. The interval range for the Impulses is 0.1 sec to 100 sec in 0.1sec steps.

### **1.7.3 Multi Frequency Interference**

Multi Frequency Interference (MFI) is unwanted tones coupled onto the loop. The classic case is a 60Hz tone induced from power lines, and its odd harmonics appearing in the voiceband spectrum. In older modems with lower baud rates, the 60Hz interference was not that detrimental to the performance of the modem. But as the rates of modems have increased all of the voiceband frequency spectrum is being used and so the 60Hz tones and its odd harmonics have an affect on modem performance.

Multi Frequency Interference is an additive impairment which is coupled onto the loop. Up to four independent tones can be programmed simultaneously. Each tone has an individual frequency and level control.

### **Programming Parameters**

There are three parameters for programming MFI tones: ENABLE, LEVEL or FREQUENCY. To change a parameter, use the appropriate remote command under the IMP command group. Below is the description for setting parameters in each of these fields.

The ENABLE parameter has only two selections: ON or OFF. When the impairment is on and the source is allocated, the impairment is then coupled to the pair and station selected during allocation.

The LEVEL parameter set the level of the tone. The TAS 240 tone level range is 15 dBrn to 75 dBrn in 0.1dB steps.

The FREQUENCY parameter set the frequency of the desired tone. The range of the frequency parameter is from 50 Hz to 4000 Hz in 1 Hz steps.

## 1.8. Feature Release History

### **Version 2.0**

Firmware release V2.0 incorporates the impairments option. This option is used to emulate the impairments required by the developing TIA PN 3857 test specification.

### **Version 1.1**

Firmware release V1.1 incorporates the Metering Pulse option. This option, which simulates Metering Pulses used to transmit billing information in Europe, is available through a hardware upgrade. The Metering Pulse option is explained in the Application Note section located in the back of this manual.

### **Version 1.01**

Firmware release V1.01 corrects a bug associated with the bridged taps used in conjunction with the custom loop feature. Please note, this problem was specific to custom loop applications, and does not affect the pre-configured loops.

This page intentionally left blank.

## 2.0. LOCAL OPERATION

---

Local operation of the TAS 240 is accomplished by using the two line display and four control keys on the front panel. The top display line shows menu parameter information. The bottom display line shows menu help information. The four control keys are:

- Minus key is used for selecting a menu and for backward parameter scrolling.
- + Plus key is used for selecting a menu and for forward parameter scrolling.
- ENTER Enter key is used for selecting a submenu and for selecting fields.
- ESC Escape key is used to return from a submenu.

## 2.1. High Level Menu Structure

Figure 2-1 illustrates the menu tree for the TAS 240. The main menu is represented by the top row of four function boxes. Any function box having a submenu is distinguished by having another function box beneath it. Those function boxes with a submenu will have a submenu indicator on the two line display.

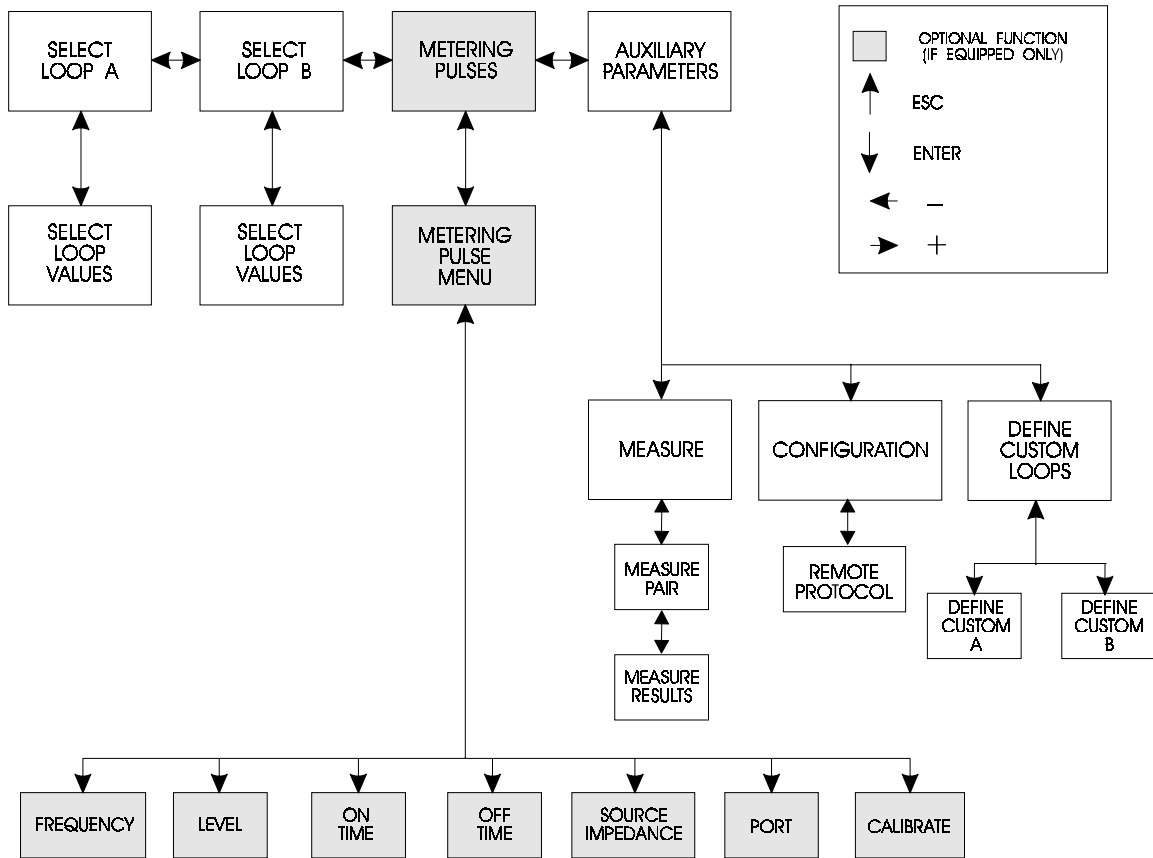

**Figure 2-1. High Level Menu Tree**

A basic TAS 240 is equipped with a control board, a Loop A board and a Loop B board. The unit can be equipped with an optional Metering Pulse board. If the optional board is missing, the high level menu tree is automatically restructured to compensate for the missing function. The sequence of front panel operations is automatically modified according to the options present.



## 2.2. Front Panel Operation

This section describes all of the local front panel displays and control key operations.

### 2.2.1. Main Menu

The main menu allows selection of four basic functions as shown in Figure 2-2. Note that one of the functions is optional. If this option is missing, the display will automatically skip over the missing function. To return to the main menu from anywhere in the menu tree, press "ESC" until you reach the top menu level.

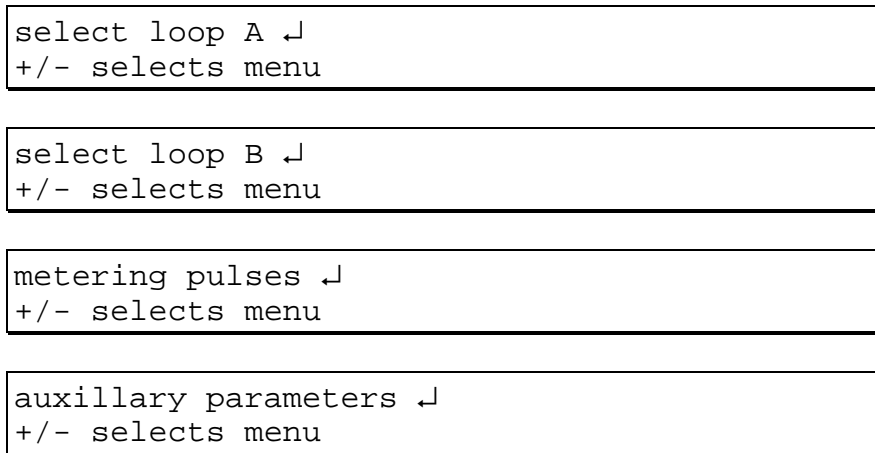

**Figure 2-2. Main Menu**

### 2.2.2. Select Loop A

Loop A is a wire board that simulates a local loop by providing a main pair for the transmission of data signals and a tracking pair to be used as a hybrid balance network.

The selections for loop A are shown in Figure 2-3. The various loops for A1/A2 include standard loop arrangements as specified by the Electronic Industries Association (EIA) and the European Telecommunications Standards Institute (ETSI). These standard loops consist of several lengths of various gauge cables which may include loading coils and bridged tap(s)s. The selections for A1/A2 are as follows:

- |         |           |
|---------|-----------|
| 1. EIA1 | 7. EIA7   |
| 2. EIA2 | 8. ETSI1  |
| 3. EIA3 | 9. ETSI2  |
| 4. EIA4 | 10. PAD   |
| 5. EIA5 | 11. CUSTA |
| 6. EIA6 | 12. NULL  |

The details for each standard loop are given in the Technical Specifications section of this manual. The PAD selection is a 6.1 db attenuation pad. The CUSTA selection allows a custom local loop to be used. The procedure to specify the custom loop will be defined in a later section. The NULL selection is a zero loss loop.

The A1-BAL allows four selections for the hybrid balance network that is to be used with loop A1. The selections are the tracking loop A2, network RC1, network RC2, or an external network. Network RC1 is a compromise balance network that is normally used with loop A1 ETSI1 and RC2 is a compromise balance network that is normally used with loop A1 ETSI2. The compromise networks are intended to provide reasonable, but not exact, balance for the ETSI loops.

The A2-TERM allows the selection of an internal 604 ohm or an external network termination for the tracking loop A2.

```
A1/A2: EIA1    A1-BAL: ext    A2-TERM: 600
+/- selects loop    Enter changes
```

```
A1/A2: EIA1    A1-BAL: ext    A2-TERM: 600
+/- selects bal    Enter changes
```

```
A1/A2: EIA1    A1-BAL: ext    A2-TERM: 600
+/- selects term    Enter changes
```

**Figure 2-3. Select Loop A**

Bolded text indicates selected field.

Loop B is an optional function which is identical to Loop A. The selections for loop B are the same as for loop A.

### 2.2.3. Auxiliary Parameters

Auxiliary parameters include three functions; the definition of custom loops, the measurement of insertion loss for any of the four loops, and the remote control configuration. Figure 2-4 shows the three possible displays for auxiliary parameters.

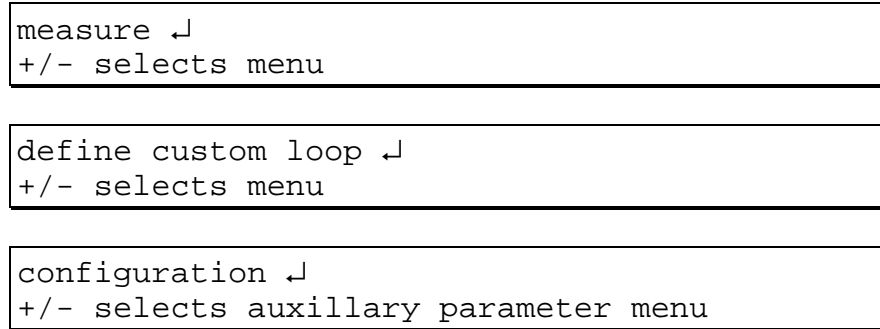

**Figure 2-4. Auxiliary Parameter Selection**

#### Measure Function

The measure function is intended to measure the insertion loss of any one of the four loops. Two test tones, 804 Hz and 1004 Hz, are injected into the Network Interface (NI) or End Office (EO) side of the selected loop and are measured at the corresponding opposite side.

The selections for the measure function are shown in Figure 2-5. The points at which the measurement is taken are at the EO and NI ends of the main loop and tracking loops A and B. The selections are as follows:

SETTING	TONE SOURCE LOCATION	MEASURE LOCATION
A1NI-EO	A1NI	A1EO
A1EO-NI	A1EO	A1NI
A2NI-EO	A2NI	A2EO
A2EO-NI	A2EO	A2NI
B1NI-EO	B1NI	B1EO
B1EO-NI	B1EO	B1NI
B2NI-EO	B2NI	B2EO
B2EO-NI	B2EO	B2NI

To perform the measurement, press the ENTER button. Note Figure 2-5 indicating the results display. To repeat the measurement, press ESC and then press ENTER again. If ESC is pressed a second time, the display returns to the auxiliary parameter selection.

```
MEASURE PAIR: A1NI-EO    loss
+/- selects pair    Enter to measure loss
```

```
A1NI-EO  804 Hz  1.5 dB  1004 Hz  1.3 dB
Esc to return
```

**Figure 2-5. Measure Function**

### Define Custom Loops

Custom loops are used when the standard loops are not appropriate for the testing conditions. Custom loops allow selection of any length (to 15 Kft) of 26 gauge and 24 gauge wire in cascade. Also, either standard loaded loop (EIA6 or EIA7) can be appended to the 26 gauge and 24 gauge wire. In addition, the custom loops can have bridged tap(s).

The selection of custom loop A or B is shown in Figure 2-6.

```
DEFINE CUSTOM LOOP: a ↵
+/- selects loop
```

**Figure 2-6. Custom Loop A or B**

After selecting loop A or B, the custom loop is defined in detail from the front panel as indicated in Figure 2-7. Link 1 is the 26 gauge portion of the loop and any length to 15 Kft may be selected. Link 2 is the 24 gauge portion of the loop and any length to 15 Kft may be selected. Link 3 is either standard loaded loop EIA6, EIA7, or none. The final selection for a custom loop is the selection of a bridged tap(s) on or off.

26AWG: <b>1k</b>	24AWG: 12k	APPEND: none	BT: on
+/- selects length		Enter changes field	

26AWG: 1k	24AWG: <b>12k</b>	APPEND: none	BT: on
+/- selects length		Enter changes field	

26AWG: 1k	24AWG: 12k	APPEND: <b>none</b>	BT: on
+/- selects length		Enter changes field	

26AWG: 1k	24AWG: 12k	APPEND: none	BT: <b>on</b>
+/- selects length		Enter changes field	

**Figure 2-7. Select Custom Loop Parameters**

Bolded text indicates selected field.

## Configuration

The configuration function is intended to arrange the TAS 240 for operation using the proper remote protocol. Figure 2-8 shows the display selecting one of three protocols; RS-232 ack/nak, RS-232 crlf, and IEEE 488 (GPIB).

The selections on the display are ack/nak, crlf, or GPIB.

REMOTE PROTOCOL: <b>ack/nak</b> ↵
+/- selects remote protocol

**Figure 2-8. Select Configuration**

If the ack/nak protocol is selected, Figure 2-9 shows the parameters associated with that protocol. Any address from 0 to 99 may be selected. Four choices can be made for data transfer rate; 4800, 2400, 1200, or 300 bps.

ACK/NAK ADDRESS: <b>1</b>	RATE: 4800
Enter changes field	

ACK/NAK ADDRESS: 1	RATE: <b>4800</b>
Enter changes field	

**Figure 2-9. ACK/NAK Configuration**

Bolded text indicates selected field.

If the crlf protocol is selected, Figure 2-10 shows the parameters associated with that protocol. Four choices can be made for data transfer rate; 4800, 2400, 1200, or 300 bps. A character length of 7 or 8, not including start and stop bits, can be selected. One stop bit is always used. A choice of parity; odd, even, or none, can be selected.

CRLF RATE: <b>4800</b> CHAR: 8      PY: odd Enter changes field
CRLF RATE: 4800      CHAR: <b>8</b> PY: odd Enter changes field
CRLF RATE: 4800      CHAR: 8      PY: <b>odd</b> Enter changes field

**Figure 2-10. CRLF Configuration**

Bolded text indicated selected field.

If the GPIB protocol is selected, Figure 2-11 shows the display which allows selection of the GPIB address from 0 to 30.

GPIB ADDRESS: <b>2</b> +/- selects GPIB address
--

**Figure 2-11. GPIB Configuration**

This page intentionally left blank.



### 3.0. REMOTE CONTROL OPERATION

---

A computer or terminal can control the TAS 240 by issuing commands to the IEEE-488 or RS-232 remote control port of the TAS 240. The TAS 240 supports three control link protocols:

- RS-232 CR/LF
- RS-232 ACK/NAK
- IEEE-488 or GPIB

**CR/LF** (carriage return/line feed) - is a simple command-line protocol, and allows control of the TAS 240 from a dumb terminal or a computer. In addition to being easiest to implement, the CR/LF protocol provides a convenient way to practice using the TAS 240 command set.

**ACK/NAK** - is a more sophisticated serial control protocol that includes error-checking and command retransmission.

**IEEE-488 or GPIB** (General Purpose Instrumentation Bus) - is the industry-standard parallel-bus instrument control protocol. The input terminator marks the end of a message from a GPIB device to the TAS 240 GPIB controller. The TAS 240 supports EOI (end-of-interrupt) as the only valid termination condition.

### 3.1. Configuring the TAS 240 for Remote Control

Before you can control TAS 240 from a remote terminal or computer, you must first set the unit's remote control configuration. The remote configuration can be set only via the TAS 240 front panel. To set the remote control configuration, perform the following steps:

1. Enter the AUXILIARY PARAMETERS menu.
2. Select the CONFIGURATION submenu using the + or - keys, and press ENTER to access the REMOTE PROTOCOL submenu.
3. In the REMOTE PROTOCOL submenu, select the desired protocol, (IEEE-488, CR/LF, or ACKNAK), using the + and - keys.
4. Press the ENTER key to access the specific options for the desired remote protocol.

For example, to configure TAS 240 for RS-232 CR/LF control, select "REMOTE PROTOCOL: crlf", and press ENTER to select the crlf submenu. Next, set the CRLF RATE, CHAR, and PY options to the desired data rate, character length, and parity. For more information on the TAS 240 CONFIGURATION menu, see Section 2, *Local Operation*.

## 3.2. Sending Commands to the TAS 240

### Command Types

The TAS 240 supports two distinct types of commands. These command types are EXECUTE commands and REPORT commands.

EXECUTE commands simply assign a value to a TAS 240 parameter. For example, the command that sets LOOPA to a specific type such as EIA1 is an executable command. If the TAS 240 receives an EXECUTE command without a parameter value, it returns the current setting of the parameter.

REPORT commands return a value. For example, the MEAS command returns the level measurement for the selected pair.

### Command Sequence

To execute a TAS 240 command, the controller must execute a simple three-step sequence:

1. Check for any pending command responses. The TAS 240 does not execute a new command if the result from a previous command has not been read.
2. Send the command to the TAS 240.
3. Read the command response from the TAS 240.

### Command Messages

A TAS 240 command message consists of one or more command frames. A command frame consists of a command group name and one or more commands. A backslash precedes and follows each command frame. A colon follows the command group name, and a comma follows each command name except the last command. The TAS 240 ignores white space within the command frame and requires that all commands be in capital letters. The command frame has the following syntax:

```
/COMMAND GROUP: COMMAND1, COMMAND2, . . . , COMMANDN/
```

All of the commands within a command frame must belong to the same command group. An example of a command group is cnfg:

```
/CNFG: LOCK/
```

The above command puts the TAS 240 in local lockout mode, disabling the ability to change parameters from the front panel. This command is an example of an EXECUTE command.

If the TAS 240 receives an EXECUTE command without a parameter value, it returns the current value of the parameter. For example, the following message queries the TAS 240 to return the standard loop parameter setting for LOOPA:

```
/LOOPA: LOOP/
```

Note that a similar command was used to set the LOOPA loop parameter:

```
/LOOPA: LOOP=EIA1/
```

An example of a REPORT command is:

```
/CNFG: VERS/
```

The above command polls the TAS 240 for its version number.

### Response Messages

The TAS 240 provides an explicit response to each command message that it receives. A command message can be one of three types:

1. Command completion message
2. Value message
3. Error message

The TAS 240 returns a command completion message in response to an EXECUTE command. The command completion message is:

```
/C/
```

The TAS 240 returns a value message in response to a REPORT command. The form of the value message is:

```
/COMMAND GROUP: COMMAND=VALUE/
```

For example, if the TAS 240 receives a message to report the insertion loss of the selected loop:

```
/MEAS:RP/
```

The TAS 240 will respond with:

```
/MEAS:RP=10.1/
```

In this case, the response indicates a measured insertion loss of 10.1 dB.

The TAS 240 returns an error message when it detects a problem with command syntax, or when it detects an internal processing error. The form of the error message is:

/COMMAND GROUP:EXXX/

Where xxx is the error number.

For example, if the controller sends the message:

/LOOPA:LOOP=EIA8/

The TAS 240 responds with:

/LOOPA:E001/

Indicating a parameter value error.

### 3.3. Remote Control Protocols

The TAS 240 provides three remote control protocol options: RS-232 CR/LF, RS-232 ACK/NAK, and GPIB. The command syntax remains the same, regardless of the remote protocol. The remote control protocol determines only the method by which the TAS 240 receives commands and provides responses.

To control the TAS 240 from a computer or terminal, you must first set the remote protocol options from the front panel. These options reside in the AUXILIARY PARAMETERS menu under the CONFIGURATION menu. Select the desired REMOTE PROTOCOL option, then access the options submenu to set the specific parameters for that protocol.

#### 3.3.1. RS-232C CR/LF Protocol

The TAS 240 RS-232 CR/LF is the most basic remote control protocol. You can use this protocol to control the TAS 240 from a data terminal or a computer. The RS-232 CR/LF protocol does not perform error checking, so you should not use this protocol unless the control terminal or computer is collocated with the TAS 240.

The TAS 240 provides a > prompt when it is ready to receive a command. To enter a command, simply type the command, then press CARRIAGE RETURN. The TAS 240 processes the command and provides a response. After the TAS 240 provides the response, it sends another > prompt to indicate that it is again ready to receive a command.

The TAS 240 can be configured for baud rates of 300, 1200, 2400, and 4800. In addition a character length of 7 or 8, and a parity of odd, even, or none can be selected. Note that the number of stop bits used by the VSLE is fixed to one. Refer to Section 2, Local Operation for specific information on how to set the CR/LF parameters.

### 3.3.2. ACK/NAK Protocol

The TAS 240 ACK/NAK protocol supports RS-232 multipoint communication between a controller and one or more TAS devices. ACK/NAK also detects command transmission errors, and provides for retransmission of corrupted commands. ACK/NAK is well suited for applications in which the TAS 240 is not collocated with the controller, such as when the TAS 240 is controlled remotely via a modem link.

The controller initiates all ACK/NAK protocol transactions. To effect a command transaction with the TAS 240, the controller must perform the following operations:

1. Poll the TAS 240 for a pending response.
2. Send the command to TAS 240.
3. Poll the TAS 240 for the command response.

#### ACK/NAK Command Transaction Example

The following example illustrates a command transaction between a controller and the TAS 240.

First, the controller polls for any pending response. This ensures that the TAS 240 response buffer is empty so that the TAS 240 can process the next command:

[ ADDR ] P<ENQ>

The TAS 240 response buffer is empty, so it responds:

[ ADDR ] <EOT>

Next, the controller sends the command to the TAS 240:

[ ADDR ] S<ENQ><SOH><STX>/LOOPA: LOOP=EIA1 / <ETX> [ CHECKSUM ]

The TAS 240 receives the command, does not detect any errors, and responds:

[ ADDR ] <ACK>

Next, the controller polls for the response to the command:

[ ADDR ] P<ENQ>

The TAS 240 has finished executing the command, so it responds:

[ ADDR ] <SOH><STX>/C / <ETX> [ CHECKSUM ]

**[addr]** - is the device address. The address can be any decimal number from 0 to 99. If the address is less than 10, the controller must left-pad the address with a space.

**[checksum]** - is the message checksum. The message checksum is a three-digit decimal number. [checksum] is the two's complement of the module 256 sum of all characters from the first address character through the <ETX> character. For example, if the checksum is 201, then the block checksum should be 055 (256-201).

<ENQ> - is the ASCII ENQUIRE control character.

<EOT> - is the ASCII END OF TRANSMISSION control character.

<SOH> - is the ASCII START OF HEADER control character.

<STX> - is the ASCII START OF TEXT control character.

<ETX> - is the ASCII END OF TEXT control character.

### Polling for a Response

When the TAS 240 receives a command from the controller, it executes the command and prepares a response. The controller must poll the TAS 240 to receive this response. The poll sequence is:

[ ADDR ] P <ENQ>

The poll message results in one of the following:

- TAS 240 does not respond.
- TAS 240 has no response waiting:

[ ADDR ] <EOT>

- TAS 240 provides a response:

[ ADDR ] <SOH> <STX> [ RESPONSE ] <ETX> [ CHECKSUM ]

The TAS 240 does not respond to a poll if one of the following conditions exists:

- The TAS 240 configuration is not proper. For example, TAS 240 does not respond if its ACK/NAK address does not match the address contained in the poll message.
- TAS 240 is currently processing a command.
- The poll message has been corrupted by an error.
- TAS 240 AC power is off.

If the controller does not receive a response from TAS 240, it should poll again. The TAS 240 responds with [addr]<EOT> if it has no response pending.



## Sending Commands to the TAS 240

To send a command to the TAS 240, the controller must assemble and send a SELECT message. The format of the SELECT message is shown below:

```
[ ADDR ] S<ENQ><SOH><STX> [ COMMAND ] <ETX> [ CHECKSUM ]
```

The select message yields one of three possible results:

- The TAS 240 does not respond to the message.
- The TAS 240 detects an error in the message:

```
[ ADDR ] <NAK>
```

- The TAS 240 receives the message and does not detect any errors:

```
[ ADDR ] <ACK>
```

The TAS 240 does not respond to the SELECT message if one of the following conditions exists:

- The TAS 240 address does not match the address contained in the SELECT message.
- The AC power to the TAS 240 is off.

The TAS 240 responds with a negative acknowledgment (NAK) if it detects a transmission error in the SELECT message (bad checksum), or if the message is too long (greater than 512 characters). If the TAS 240 detects a transmission error in the message, the controller should send the message again.

## Receiving Responses from the TAS 240

The TAS 240 provides a command response when it is polled by the controller. If the controller detects a transmission error in the TAS 240 response, it should perform the following steps:

1. Poll the TAS 240 until it responds with:

```
[ ADDR ] <EOT>
```

1. Send the message again.
2. Poll the TAS 240 again for the response.

When using ACK/NAK protocol, the TAS 240 is hardwired to use 7 data bits, odd parity, and 1 stop bit. However, the unit can be programmed to an address in the range from 0 - 99, and a baud rate of 300, 1200, 2400, or 4800. Refer to Section 2 *Local Operation* for specific information on how to set the ACK/NAK parameters.

### 3.3.3. GPIB Protocol

The TAS 240 GPIB protocol supports a parallel bus control architecture in which the TAS 240 is one of the devices being controlled. The controller must meet all GPIB electrical and mechanical specifications.

The controller initiates all GPIB protocol transactions. In order to communicate with the TAS 240, a GPIB controller must perform the following operations:

1. Poll the TAS 240 for a pending response.
2. Send the message to TAS 240.
3. Poll the TAS 240 for the command response.

The TAS 240 provides a GPIB status byte to indicate its current state. The possible states are:

- IDLE - 02H
- BUSY - 01H
- READY TO RESPOND (RTR) - 04H or 44H

**IDLE** - indicates that the TAS 240 does not have a message to send and is ready to accept a command.

**BUSY** - indicates that the TAS 240 is currently processing a command. The TAS 240 does not accept a new command until it has finished processing the current command and has provided the response to the controller.

**READY TO RESPOND (RTR)** - indicates that the TAS 240 currently has a message to send to the controller. The TAS 240 is always Ready to Respond when it finishes processing a command.

When the TAS 240 is ready to respond, it activates the service request line (SRQ), and sets the RTR status to 44 hex. After the controller conducts the serial poll, SRQ goes inactive, and the TAS 240 sets the RTR status to 04 hex. Figure 3-1 shows a flowchart for a typical bus controller sequence.

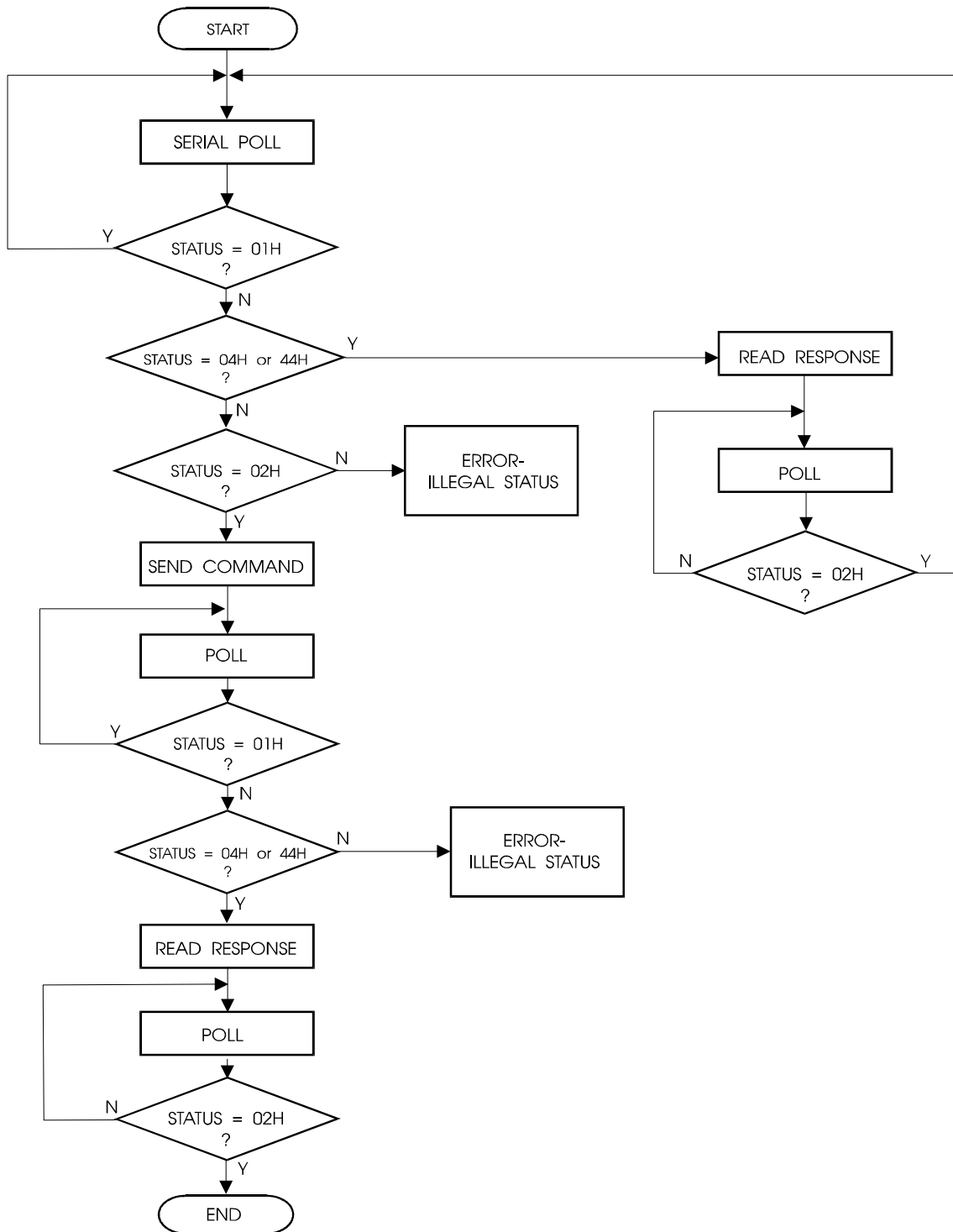

Figure 3-1. GPIB Controller Sequence

### **Polling for a Response**

The controller must conduct a serial poll to receive a command response from TAS 240. The following example shows the typical GPIB sequence required to achieve a serial poll of the TAS 240. The actual bus sequence may be different:

1. ATN active
2. UNT - (UNTalk)
3. UNL - (UNListen)
4. SPE - (Serial Poll Enable)
5. MTA - (TAS 240 My Talk Address)
6. Controller programmed to listen
7. ATN inactive
8. TAS 240 sends status
9. ATN active
10. SPD - (Serial Poll Disable)
11. UNT - (UNTalk)

Always conduct a serial poll before sending a command to the TAS 240. If the TAS 240 has a pending message to send, it does not accept a new command. Sending Commands to the TAS 240.

The following example shows the typical GPIB sequence required to send a command to the TAS 240. Your actual bus sequence may be different.

1. ATN active
2. UNT - (UNTalk)
3. UNL - (UNListen)
4. MLA - (TAS 240 My Listen Address)
5. Controller programmed to talk
6. ATN inactive
7. Controller sends command to the TAS 240 and asserts EOI with last command character
8. ATN active
9. UNL - (UNListen)

Command strings must not be terminated with CARRIAGE RETURN or CARRIAGE RETURN+LINE FEED. The controller must signal the end of a command message by asserting EOI (end of interrupt) while it sends the last character of the message.

Some commands require several seconds of the TAS 240 processing time. While the TAS 240 completes most commands in less than 100 msec., some commands may require up to 3 seconds. The controller should conduct serial polls until the TAS 240 status is RTR.

### **Receiving Responses from the TAS 240**

The following example shows the typical GPIB sequence required to receive a command from TAS 240. Your actual bus sequence may be different.

1. ATN active
2. UNT - (UNTalk)
3. UNL - (UNListen)
4. MTA - (TAS 240 My Talk Address)
5. Controller programmed to listen
6. ATN inactive
7. TAS 240 sends data to controller
8. Controller reasserts control when EOI goes active
9. ATN active
10. UNT - (UNTalk)

The TAS 240 does not terminate its response message with a CARRIAGE RETURN or CARRIAGE RETURN+LINE FEED. The TAS 240 signals the end of a response message by raising EOI while it sends the last character of the response.

When using GPIB protocol, the TAS 240 can be set to an address in the range from 0 - 30. Refer to Section 2, *Local Operation* for specific information on how to set the GPIB address.

This page intentionally left blank.

## 4.0. COMMAND SUMMARY

---

### 4.1. TAS 240 Remote Commands Reference

The TAS 240 has six command groups, each with multiple commands. The following table outlines the command groups and their associated commands.

GROUP	COMMAND	DESCRIPTION
CNFG	LOC	Return to local control
	LOCK	Enable local lockout
	MODL	Report model number
	OPTS	Reports the hardware configuration
	RESET	Reset to default values
	STAT	Report TAS 240 status
	VERS	Report Version number
LOOPA	LOOP	Selects the main and tracking A loop
	BAL	Selects circuit for Balance A Out Port
	TERM	Selects the termination for the tracking loop
	26AWG	Selects custom loop length for 26 gauge link
	24AWG	Selects custom loop length for 24 gauge link
	APPEND BT	Select one of two loaded loops to append to custom loop Selects bridged tap(s) on or off.
LOOPB❖	LOOP	Selects the main and tracking B loop
	BAL	Selects circuit for Balance B Out Port
	TERM	Selects the termination for the tracking loop
	26AWG	Selects custom loop length for 26 gauge link
	24AWG	Selects custom loop length for 24 gauge link
	APPEND BT	Select one of two loaded loops to append to custom loop Selects bridged tap(s) on or off.
MEAS	FREQ	Specifies the measurement tone frequency
	PAIR	Selects the wire pair to be measured
	RP	Reports insertion loss measurement result
METER❖	SIGNAL	Enables/disables metering pulse generator
	FREQ	Specifies the frequency of the metering pulse
	LEVEL	Selects output of the pulse generator
	ON	Selects on time for the cadenced generator
	OFF	Selects off time for the cadenced generator
	PORT	Selects main pair for metering pulses
	IMPED	Selects source impedance for metering pulse generator
	CAL	Initiates a level calibration

❖ Commands for optional equipment should not be sent to systems which do not contain those options.

GROUP	COMMAND	DESCRIPTION
IMP ❖	SIGNAL	Enables/disables impairments generator
	PORT	Selects main pair for impairments generator
	INL	Selects level of the impulse noise
	INI	Selects impulse noise interval
	INS	Enables/disables impulse noise
	NSEL	Selects level of additive noise
	NSES	Enables/disables additive noise
	MFILx	Selects interference level of tones 1 to 4
	MFIFx	Selects interference frequency of tones 1 to 4
	MFISx	Enables/disables interference tones 1 to 4

❖ Commands for optional equipment should not be sent to systems which do not contain those options.



## 4.2. TAS 240 Configuration (CNFG)

### Command Group Format

/CNFG: LOC, LOCK, MODL, OPTS, STAT, VERS, RESET/

### Command Group Description

Commands in the CNFG group report or execute the TAS 240 configuration options and status.

### Commands Description

Command: /CNFG: LOC/

Response: /C/

This command enables control of the TAS 240 via the front panel as well as from the selected remote protocol.

Command: /CNFG: LOCK/

Response: /C/

This command prevents parameters from being changed from the front panel. Although parameter values are locked, menu navigation is still permitted from the front panel.

Command: /CNFG: MODL/

Response: /CNFG: MODL=240/

This command instructs the TAS 240 to return the unit's model number.

Command: /CNFG: OPTS/

Response: /CNFG: OPTS=XXX/

This command requests the TAS 240 report its hardware configuration. The configuration is represented by a three digit number coded in binary. The three digits stand for the four boards that can be present in a TAS 240. From left to right (most significant to least significant), these are the LOOPA board, the LOOPB board and the optional METERING PULSE or IMPAIRMENTS GENERATOR board. If the digit is a '1', the respective LOOP board **is** present. If the digit is a '1' in the last location, the METERING PULSE board **is** present. If the digit is a '2' in the last location, the IMPAIRMENTS GENERATOR board **is** present. If the digit is a '0', the board is **not** present.

Command: /CNFG: STAT/

Response: /CNFG: STAT=000/

This command returns the status of the TAS 240. A non-zero status code indicates a system error condition.

Command: /CNFG: VERS/  
 Response: /CNFG: VERS=1.00/

This command instructs the TAS 240 to return the version number of the firmware resident in the ROM of the unit.

Command: /CNFG: RESET/  
 Response: /C/

This command instructs the TAS 240 to reset parameters to factory default. The default values for those parameters are as follows:

Loop A:	Null	Bridged tap(s) A:	off
Loop B: (option)	Null	Bridged tap(s) B:	off
Bal A:	A2	Measure Point:	A1NI-E0
Bal B:	B2	Measure Frequency:	1004 Hz
Term A:	Ext	Metering Pulse (option)	
Term B:	Ext	Frequency:	16.00 kHz
Custom Loop:	A	Pulse Level:	22 dBm
26AWG A:	0 Kft	Pulse On Time:	120 milliseconds
26AWG B:	0 Kft	Pulse Off Time:	220 milliseconds
24AWG A:	0 Kft	Source Impedance:	0 ohms
24AWG B:	0 Kft	Generator Signal:	off
APPEND A:	None	Generator Port:	A1E0
APPEND B:	None		

**Impairments generator (option)**

Impulse noise level	40 dBrnC
Impulse noise interval	1 second
Impulse noise status	OFF
Additive noise level	22.0 dBrn
Additive noise status	OFF
Tone 1 interference level	70.0 dBrn
Tone 2 interference level	41.0 dBrn
Tone 3 interference level	30.0 dBrn
Tone 4 interference level	21.0 dBrn
Tone 1 interference frequency	60 Hz
Tone 2 interference frequency	180 Hz
Tone 3 interference frequency	300 Hz
Tone 4 interference frequency	540 Hz
Status for all tones	OFF
Impairments signal	ON
Impairments port	A1EO

Several default parameters associated with the remote control interface are not affected by the RESET command, and are recalled only if the non-volatile RAM fails to retain all present parameter settings at power-up.

Ack/Nak Address:	1
GPIB Address:	1
Remote Protocol:	CRLF
Ack/Nak Baud Rate:	2400
CRLF Baud Rate:	1200
CRLF Character Length:	7
CRLF Parity:	odd

### 4.3. TAS 240 Loop A (LOOPA)

#### Command Group Format

```
/LOOPA: LOOP=ttttt, BAL=bbb, TERM=sss, 26AWG=rr,
24AWG=qq, APPEND=ppppp, BT=ON or OFF/
```

#### Command Group Description

The LOOPA command chooses the impedance and insertion loss characteristics for Loop A using the LOOP subcommand. The main pair characteristic and the tracking pair characteristic are chosen with a single command. The characteristic may be chosen from a list of standards, or a custom characteristic may be designed by the user using the 26AWG, 24AWG, APPEND, and BT subcommands.

The circuit connected to the A1 balance port is chosen with the BAL subcommand. The balance circuit may be chosen from a list, or may be connected externally by the user.

The termination on the network interface end of the tracking loop A2 is chosen with the TERM subcommand. Termination may be a 600 ohm internal impedance, or may be connected externally by the user.

#### Command Description

Command: /LOOPA:LOOP=ttttt/  
Response: /C/

The LOOP command specifies the loop to be inserted at station A for the main and tracking pairs A1 and A2.

'ttttt' selects the loop from the following list:

EIA1	Proposed EIA loop number 1 (Main and Tracking Pairs)
EIA2	Proposed EIA loop number 2 (Main and Tracking Pairs)
EIA3	Proposed EIA loop number 3 (Main and Tracking Pairs)
EIA4	Proposed EIA loop number 4 (Main and Tracking Pairs)
EIA5	Proposed EIA loop number 5 (Main and Tracking Pairs)
EIA6	Proposed EIA loop number 6 (Main and Tracking Pairs)
EIA7	Proposed EIA loop number 7 (Main and Tracking Pairs)
ETSI1	ETSI loop number 1 (Main and Tracking Pairs)
ETSI2	ETSI loop number 2 (Main and Tracking Pairs)
PAD	6.1 dB attenuator pad (Main and Tracking Pairs)
CUSTA	User defined loop (Main and Tracking Pairs)
NULL	Short-circuit condition, no wire

Command: /LOOPA:BAL=bbb/  
 Response: /C/

The BAL command specifies the circuit to be connected to the main pair A1 balance port.

'bbb' selects the balance circuit option from the following list:

- A2 A1 uses the tracking pair A2 as the balance network
- RC1 A1 uses RC compromise balance network for ETSI1 as the balance network
- RC2 A1 uses RC compromise balance network for ETSI2 as the balance network
- EXT A1 uses the circuit at the two-wire external balance connector on the back panel as the balance network

Command: /LOOPA:TERM=sss/  
 Response: /C/

The TERM command specifies the termination option at the network interface end of the tracking pair A2.

'sss' selects the termination option from the following list:

- EXT No internal termination
- 600 Internal 600 ohm resistive termination

Command: /LOOPA:26AWG=rr/  
 Response: /C/

The 26AWG command is used when LOOP=CUSTA is selected. 26AWG allows the user to specify the length of 26 AWG wire to be used in the custom loop. 'rr' ranges from 00 to 15 to specify the length of 26 AWG wire in 1 Kft increments.

Command: /LOOPA:24AWG=qq/  
 Response: /C/

The 24AWG command is used when LOOP=CUSTA is selected. 24AWG allows the user to specify the length of 24 AWG wire to be used in the custom loop. 'qq' ranges from 00 to 15 to specify the length of 24 AWG wire in 1 Kft increments.

Command: /LOOPA:APPEND=pppp/  
 Response: /C/

The APPEND command is used when LOOP=CUSTA is selected. APPEND allows the user to include the 22AWG/24AWG/COIL link in the custom loop. The link may be included as EIA6 or EIA7.

'pppp' selects the link option from the following list:

- |      |   |
|------|---|
| NONE | Excludes 22AWG/24AWG/COIL link from custom loop       |
| EIA6 | Includes 22AWG/24AWG/COIL link in custom loop as EIA6 |
| EIA7 | Includes 22AWG/24AWG/COIL link in custom loop as EIA7 |

Command: /LOOPA:BT=ON(OFF)/

Response: /C/

The BT command is used when LOOP=CUSTA is selected. BT=ON allows the user to include the 1500 ft 26AWG bridged tap(s) section in the custom loop. If BT=OFF is chosen, the 1500 ft 26AWG bridged tap(s) section is not included.

## 4.4. TAS 240 Loop B (LOOPB) (Optional)

### Command Group Format

```
/LOOPB: LOOP=ttttt, BAL=bbb, TERM=sss, 26AWG=rr,
24AWG=qq, APPEND=ppppp, BT=ON or OFF/
```

### Command Group Description

The LOOPB command chooses the impedance and insertion loss characteristics for Loop B using the LOOP subcommand. The main pair characteristic and the tracking pair characteristic are chosen with a single command. The characteristic may be chosen from a list of standards, or a custom characteristic may be designed by the user using the 26AWG, 24AWG, APPEND, and BT subcommands.

The circuit connected to the B1 balance port is chosen with the BAL subcommand. The balance circuit may be chosen from a list, or may be connected externally by the user.

The termination on the network interface end of the tracking loop B2 is chosen with the TERM subcommand. Termination may be a 600 ohm internal impedance, or may be connected externally by the user.

### Command Description

Command: /LOOPB:LOOP=ttttt/  
Response: /C/

The LOOP command specifies the loop to be inserted at station B for the main and tracking pairs B1 and B2.

'tttt' selects the loop from the following list:

EIA1	Proposed EIA loop number 1 (Main and Tracking Pairs)
EIA2	Proposed EIA loop number 2 (Main and Tracking Pairs)
EIA3	Proposed EIA loop number 3 (Main and Tracking Pairs)
EIA4	Proposed EIA loop number 4 (Main and Tracking Pairs)
EIA5	Proposed EIA loop number 5 (Main and Tracking Pairs)
EIA6	Proposed EIA loop number 6 (Main and Tracking Pairs)
EIA7	Proposed EIA loop number 7 (Main and Tracking Pairs)
ETSI1	ETSI loop number 1 (Main and Tracking Pairs)
ETSI2	ETSI loop number 2 (Main and Tracking Pairs)
PAD	6.1 dB attenuator pad (Main and Tracking Pairs)
CUSTB	User defined loop (Main and Tracking Pairs)
NULL	Short-circuit condition, no wire

Command: /LOOPB:BAL=bbb/  
Response: /C/

The BAL command specifies the circuit to be connected to the main pair B1 balance port.

'bbb' selects the balance circuit option from the following list:

- B2 B1 uses the tracking pair B2 as the balance network
- RC1 B1 uses RC compromise balance network for ETSI1 as the balance network
- RC2 B1 uses RC compromise balance network for ETSI2 as the balance network
- EXT B1 uses the circuit at the two-wire external balance connector on the back panel as the balance network

Command: /LOOPB:TERM=sss/  
Response: /C/

The TERM command specifies the termination option at the network interface end of the tracking pair B2.

'sss' selects the termination option from the following list:

- EXT No internal termination
- 600 Internal 600 ohm resistive termination

Command: /LOOPB:26AWG=rr/  
Response: /C/

The 26AWG command is used when LOOP=CUSTB is selected. 26AWG allows the user to specify the length of 26 AWG wire to be used in the custom loop. 'rr' ranges from 00 to 15 to specify the length of 26 AWG wire in 1 Kft increments.

Command: /LOOPB:24AWG=qq/  
Response: /C/

The 24AWG command is used when LOOP=CUSTB is selected. 24AWG allows the user to specify the length of 24 AWG wire to be used in the custom loop.

'qq' ranges from 00 to 15 to specify the length of 24 AWG wire in 1 Kft increments.

Command: /LOOPB:APPEND=pppp/  
Response: /C/



The APPEND command is used when LOOP=CUSTB is selected. APPEND allows the user to include the 22/24/COIL link in the custom loop. The link may be included as EIA6 or EIA7.

'pppp' selects the link option from the following list:

- |      |   |
|------|---|
| NONE | Excludes 22/24/COIL link from custom loop       |
| EIA6 | Includes 22/24/COIL link in custom loop as EIA6 |
| EIA7 | Includes 22/24/COIL link in custom loop as EIA7 |

Command: /LOOPB:BT=ON(OFF)/

Response: /C/

The BT command is used when LOOP=CUSTB is selected. BT=ON allows the user to include the 1500 ft 26 AWG bridged tap(s) section in the custom loop. If BT=OFF is chosen, the 1500 ft 26 AWG bridged tap(s) section is not included.

## 4.5. TAS 240 Measure (MEAS)

### Command Group Format

/MEAS: PAIR=pppp-pp, FREQ=ffff, RP/

### Command Group Description

The MEAS command allows the user to measure the insertion loss of any of the four pairs by injecting a tone at any frequency from 200 Hz to 3600 Hz in 1 Hz increments.

### Command Description

Command: /MEAS:PAIR=pppp-pp/

Response: /C/

The PAIR command specifies the wire pair to be measured. Loop A main, Loop A tracking, Loop B main or Loop B tracking can be selected.

'pppp-pp' selects the pair to be measured from the following list:

A1NI-EO	Inject tones at Loop A main pair NI, measure at EO
A1EO-NI	Inject tones at Loop A main pair EO, measure at NI
A2NI-EO	Inject tones at Loop A tracking pair NI, measure at EO
A2EO-NI	Inject tones at Loop A tracking pair EO, measure at NI
B1NI-EO	Inject tones at Loop B main pair NI, measure at EO
B1EO-NI	Inject tones at Loop B main pair EO, measure at NI
B2NI-EO	Inject tones at Loop B tracking pair NI, measure at EO
B2EO-NI	Inject tones at Loop B tracking pair EO, measure at NI

Command: /MEAS:FREQ=ffff/

Response: /C/

The FREQ command specifies the measurement frequency.

'ffff' selects the frequency of the tone in Hertz from 200 Hz to 3600 Hz, in 1 Hz steps.

Command: /MEAS:RP/

Response: /MEAS:RP=11.1/

The RP command reports the insertion loss measurement in 0.1dB steps.

## 4.6. Metering Pulse (METER) (Optional)

### Command Group Format

```
/METER: SIGNAL=xxx, FREQ=ff.ff, LEVEL=vv, ON=nn.nnn,
OFF=oo.ooo, PORT=ssss, IMPED=iii, CAL/
```

### Command Group Description

The METER command allows the user to program all parameters associated with the metering pulse generator including level, frequency of the pulse waveform, cadence, source impedance, and port. The calibration command can also be performed using remote operation.

### Command Description

The SIGNAL command turns the metering pulse generator on or off.

```
Command: /METER: SIGNAL=xxx/
Response: /C/
```

'xxx' can be either ON or OFF.

The FREQ command specifies the frequency of the metering pulse generator waveform.

```
Command: /METER:FREQ=ff.ff/
Response: /C/
```

'ff.ff' selects the frequency in kilohertz in the range from 11.50 kHz to 16.50 kHz in .01 kHz (10 Hz) steps.

The LEVEL command specifies the output level of the metering pulse generator waveform.

```
Command: /METER:LEVEL=vv/
Response: /C/
```

'vv' selects the level in dBm in the range from -28 dBm (relative to 600 ohms) to 23 dBm (relative to 600 ohms) in 1 dBm steps.

The ON command specifies the on time for the cadenced signal.

```
Command: /METER:ON=nn.nnn/
Response: /C/
```

'nn.nnn' selects the on time in the range from 0.005 seconds (5 ms) to 30.000 seconds in 0.005 seconds (5 ms) steps.

The OFF command specifies the off time for the cadenced signal.

Command: /METER:OFF=oo.ooo/  
Response: /C/

'oo.ooo' selects the off time in the range from 0.000 seconds to 30.000 seconds in 0.005 seconds (5 ms) steps.

The PORT command specifies the main pair to which the metering pulses will be switched, or connects the metering pulse generator directly to the rear panel.

Command: /METER:PORT=ssss/  
Response: /C/

'ssss' selects the connection from the following list:

A1EO	Connects to EO end of pair A1
A1NI	Connects to NI end of pair A1
B1EO	Connects to EO end of pair B1
B1NI	Connects to NI end of pair B1
REAR	Connects the generator to the rear panel terminal block

The IMPED command specifies a user-programmable source impedance for the metering pulse generator.

Command: /METER:IMPED=iii/  
Response: /C/

'iii' is chosen from the following list:

0	0 ohms
50	50 ohms
100	100 ohms
150	150 ohms
200	200 ohms

CAL - Initiates a level calibration for the load currently present.

Command: /METER:CAL/  
Response: /C/

## 4.7. Impairments Generator (IMP) (Optional)

### Command Group Format

```
/IMP: SIGNAL=xxx, PORT=ssss, INL=iii, INI=ttt, INS=hhh,  
NSEL=lll, NSES=aaa, MFILx=mmm, MFIFx=ffff, MFISx=ooo/
```

### Command Group Description

The IMP command allows the user to program all parameters associated with the impairments generator including levels, frequencies, intervals, and status of impairments as well as impairments bypass and port.

### Command Description

The SIGNAL command turns the impairments generator on or off.

```
Command: /IMP: SIGNAL=xxx/  
Response: /C/
```

'xxx' can be either ON or OFF.

The PORT command specifies the main pair to which the impairments will be switched, or connects the impairment generator directly to the rear panel.

```
Command: /IMP:PORT=ssss/  
Response: /C/
```

'ssss' selects the connection from the following list:

AIEO	Connects to EO end of pair A1
AINI	Connects to NI end of pair A1
B1EO	Connects to EO end of pair B1
B1NI	Connects to NI end of pair B1
REAR	Connects the generator to the rear panel terminal block

The INL command specifies the level of the impulse noise.

```
Command: /IMP:INL=iii/  
Response: /C/
```

'iii' selects the level in dBmC in the range from 30.0 dBmC to 70.0 dBmC in 0.1 dB steps.

The INI command specifies the interval of when impulse noise will be present.

Command: /IMP:INI=ttt/

Response: /C/

'ttt' selects the interval in seconds in the range from 0.1 to 100 seconds in 10 ms steps.

The INS command specifies the status of the impulse noise.

Command: /IMP:INS=hhh/

Response: /C/

'hhh' can be either ON or OFF.

The NSEL command specifies the level of the additive noise.

Command: /IMP:NSEL=lll/

Response: /C/

'lll' selects the level in dBrn in the range from 15.0 dBrn to 50.0 dBrn in 0.1 dB steps.

The NSES command specifies the status of the additive noise.

Command: /IMP:NSES=aaa/

Response: /C/

'aaa' can be either ON or OFF.

The MFILx command specifies the level of the interference tones. Where x determines which tone is being modified (1 to 4).

Command: /IMP:MFILx=mmm/

Response: /C/

'mmm' selects the level in dBrn in the range from 15.0 dBrn to 75.0 dBrn in 0.1 dB steps.

The MFIF<sub>x</sub> command specifies the frequency of the interference tones. Where x determines which tone is being modified (1 to 4).

Command: /IMP:MFIF<sub>x</sub>=ffff/

Response: /C/

'ffff' selects the frequency in Hz in the range from 10 Hz to 4000 Hz in 1 Hz steps.

The MFIS<sub>x</sub> command specifies the status of the interference tones. Where x determines which tone is being modified (1 to 4).

Command: /IMP:MFIS<sub>x</sub>=ooo/

Response: /C/

'ooo' can be either ON or OFF.

This page intentionally left blank.



## 5.0. ERROR CODES

---

Error codes 001 through 009 may be encountered during the operation of the TAS 240. Error codes 010 through 037 may be encountered while the TAS 240 automatic diagnostic program is running (during the initial powerup).

<u>ERROR CODES</u>	<u>DESCRIPTION</u>
001	Parameter Value Error
002	Parameter ID Error
003	Not Used
004	Not Used
005	Unit Not Equipped To Support This Feature
006	Unable to Measure Load
007	Unable to Produce Desired Level Across Load
008	Metering Pulse Generator Off During Calibration
009	Not Used
010	Loop A1 26AWG 3Kft Failed
011	Loop A2 26AWG 3Kft Failed
012	Loop B1 26AWG 3Kft Failed
013	Loop B2 26AWG 3Kft Failed
014	Loop A1 26AWG 12 Kft Failed
015	Loop A2 26AWG 12 Kft Failed
016	Loop B1 26AWG 12Kft Failed
017	Loop B2 26 AWG 12Kft Failed
018	Loop A1 24AWG 3Kft Failed
019	Loop A2 24AWG 3Kft Failed
020	Loop B1 24AWG 3Kft Failed
021	Loop B2 24AWG 3Kft Failed
022	Loop A1 24AWG 12Kft Failed
023	Loop A2 24AWG 12Kft Failed
024	Loop B1 24AWG 12Kft Failed

<b><u>ERROR CODES</u></b>	<b><u>DESCRIPTION</u></b>
025	Loop B2 24AWG 12Kft Failed
026	Loop A1 Pad Failed
027	Loop A2 Pad Failed
028	Loop B1 Pad Failed
029	Loop B2 Pad Failed
030	Loop A1 EIA7 Failed
031	Loop A2 EIA7 Failed
032	Loop B1 EIA7 Failed
033	Loop B2 EIA7 Failed
034	Loop A1 Null Failed
035	Loop A2 Null Failed
036	Loop B1 Null Failed
037	Loop B2 Null Failed

## 6.0. TECHNICAL SPECIFICATIONS

---

### 6.1. General

#### AC Power

Voltage	100-240 VAC
Frequency	50/60 Hz
Power	60 Watts (maximum)
Fuse Type	2A, 250V slow-blow fuse

#### Operating Environment

Temperature	0° to 50° C (32° to 122° F)
Humidity	10% to 90%, noncondensing

#### Dimensions and Weight

Height	3.5 inches
Width	17 inches
Depth	14.4 inches
Weight	20 pounds

## 6.2. Wire Simulation

### Type

Bi-directional twisted pair, polyethylene insulated cable (PIC) insulated, 70 degrees F as published in AT&T PUB 62310: 22, 24, 26 American Wire Gauge (AWG)

### Lengths

26 AWG link:	0 to 15 Kft in 1 Kft steps
24 AWG link:	0 to 15 Kft in 1 Kft steps
24 AWG/22 AWG/Coil link	EIA Loop 6 or EIA Loop 7

### Simulation Method

Passive RLC sections

### Accuracy (1 Kft 26 AWG)

Gain Response:	+/-5% and +/-0.5 dBm from 200 to 5000 Hz
Phase Response:	+/-5% and +/-5° from 200 to 5000 Hz

### Accuracy (1 Kft 24 AWG)

Gain Response:	+/-5% and +/-0.5 dBm from 200 to 5000 Hz
Phase Response:	+/-5% and +/-5° from 200 to 5000 Hz

### Accuracy (EIA Loops 1 to 5 and ETSI Test Loops)

Gain Response:	+/-5% and +/-0.5 dBm from 200 to 5000 Hz
Phase Response:	+/-5% and +/-5° from 200 to 5000 Hz
Impedance:	+/-5% and +/-5 ohms from 200 to 5000 Hz

### Accuracy (EIA6 and EIA7 Loops)

Gain Response:	+/-5% and +/-0.5 dBm from 200 to 3400 Hz +/-7% and +/-1.0 dBm from 3401 to 5000 Hz
Phase Response:	+/-5% and +/-0.5° from 200 to 3400 Hz +/-7% and +/-1.0° from 3401 to 5000 Hz

### Maximums

Maximum Voltage from Tip to Ring:	400 Volts
Maximum Loop Current:	100 mA

### 6.3. Test Interfaces

#### Loop A, Loop B Rear Panel Connectors

The rear panel connectors are 8-pin RJ45 jacks having a maximum tip to ring voltage of 400 volts and a maximum loop current of 100 mA.

PIN #	NAME
1	N.C.
2	N.C.
3	N.C.
4	Tip
5	Ring
6	N.C.
7	N.C.
8	N.C.

**Table 6-1. RJ45 Modular Connectors Pin Assignments (Both Loop A and Loop B Connectors)**

PIN #	NAME
1	Loop A1 EO Tip
2	Loop A1 EO Ring
3	Loop A1 NI Tip
4	Loop A1 NI Ring
5	Loop A2 EO Tip
6	Loop A2 EO Ring
7	Loop A2 NI Tip
8	Loop A2 NI Ring
9	A Balance Out B1
10	A Balance Out B2
11	A Balance Ext In B1
12	A Balance Ext In B2

**Table 6-2. 12 Pin Terminal Block Pin Assignments for Loop A**

<b>PIN #</b>	<b>NAME</b>
1	Loop B1 EO Tip
2	Loop B1 EO Ring
3	Loop B1 NI Tip
4	Loop B1 NI Ring
5	Loop B2 EO Tip
6	Loop B2 EO Ring
7	Loop B2 NI Tip
8	Loop B2 NI Ring
9	B Balance Out B1
10	B Balance Out B2
11	B Balance Ext In B1
12	B Balance Ext In B2

**Table 6-3. 12 Pin Terminal Block Pin Assignments for Loop B**

## 6.4. Remote Control Interfaces

### RS-232 (DTE)

Connector Type	DB25, male
Bit Rates	300, 1200, 2400, or 4800 bps
Character Size	7 or 8 bits
Parity	even, odd, or none
Stop Bits	1 (unit will also accept 1.5, or 2 stop bits)
Pin Assignments	All unused pins have no connection

PIN #	NAME
1	GND (protective ground)
2	TxD (transmit data)
3	RxD (receive data)
4	RTS (request to send)
5	CTS (clear to send)
6	DSR (data set ready, not checked)
7	GND (signal ground)
20	DTR (data terminal ready, active)

**Table 6-4. RS-232 (DTE) Interface Pin Assignments**





## 6.5. Metering Pulse Interface

### Four Pin Terminal Block

PIN #	NAME
1	Metering Pulse In +
2	Metering Pulse In -
3	Metering Pulse Out +
4	Metering Pulse Out -

**Table 6-6. Metering Pulse Interface Four Pin Terminal Block Assignments**

## 6.6. Impairments Interface

### Four Pin Terminal Block

PIN #	NAME
1	Impairments Out +
2	Impairments Out -
3	Impairments Out +
4	Impairments Out -

**Table 6-7. Impairments Interface Four Pin Terminal Block Assignments**

## 6.7. Crosstalk Between Loops

The crosstalk between loops is less than 55 dB for frequencies less than 50 KHz.

## 6.8. ETSI Balance Networks

### ETSI1 Compromise Balance Network (RC1)

The balance network is a passive RC network.

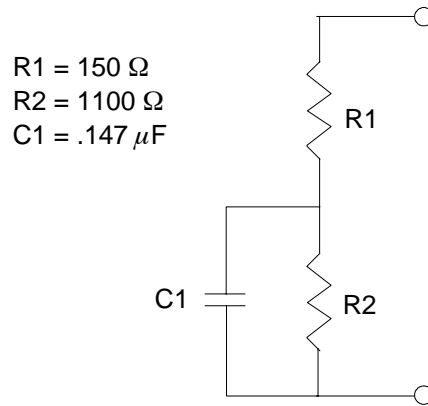

Figure 6-1. ETSI1 Compromise Balance Network (RC1)

### ETSI2 Compromise Balance Network (RC2)

The balance network is a passive RC network.

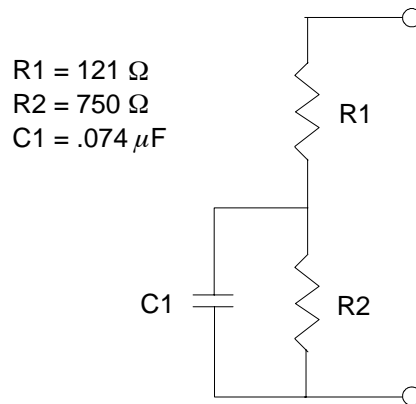
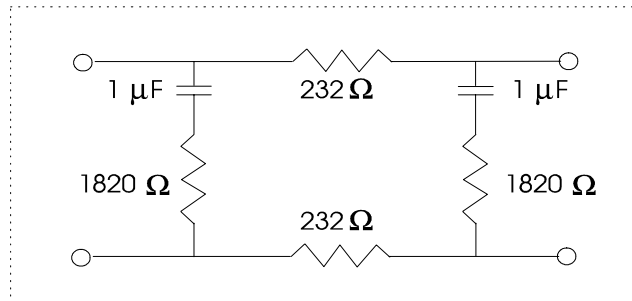

Figure 6-2. ETSI2 Compromise Balance Network (RC2)

### 6.9. Pad

Signals through the TAS 240 may have a nominal 6.1 dB attenuator pad inserted between the EO port and NI port. The schematic for the pad is shown below.



**Figure 6-3. Pad**

The pad is intended to provide impedance matching between the Network Emulator at the EO end and the device(s) attached at the NI end. The pad will provide a 600 Ohm +/- 10% termination for a load between 400 and 800 ohms.

### 6.10. Loop Definitions

The following local loops, shown in Figure 6-4, characterize the seven EIA models.

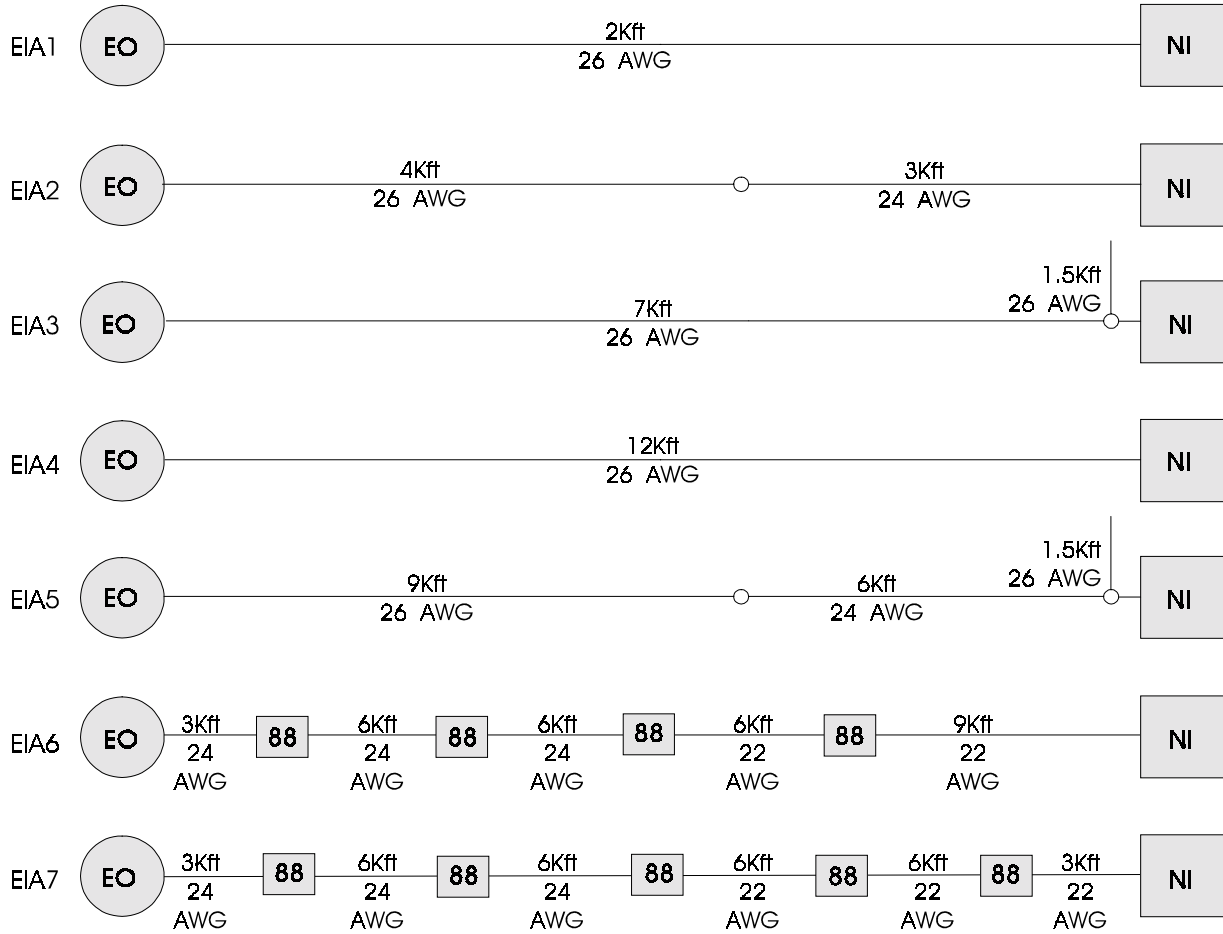

Figure 6-4. EIA Loops

The following local loops, shown in Figure 6-5, characterize the two ETSI models.

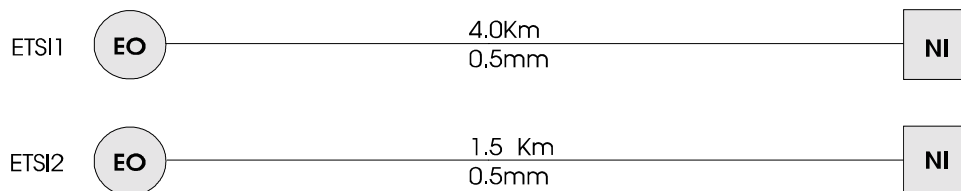
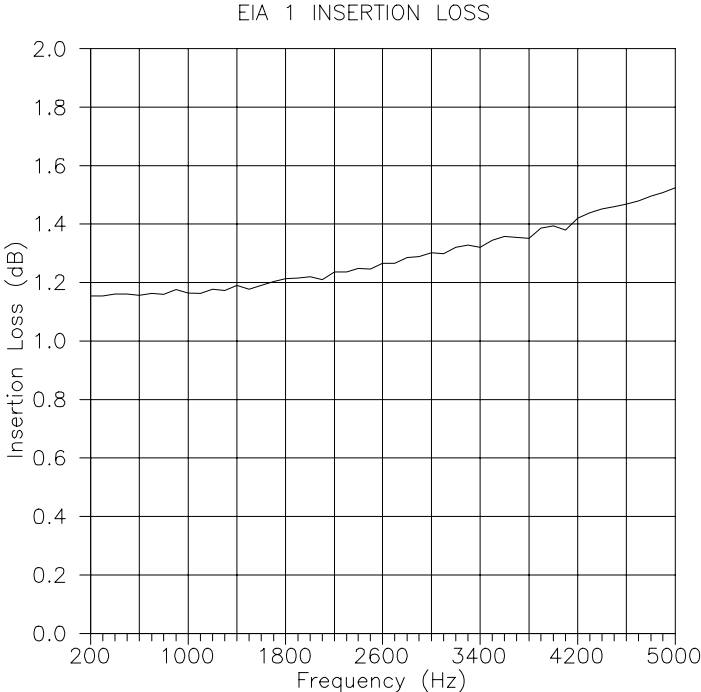

Figure 6-5. ETSI Loops

### 6.11. Insertion Loss Graphs

Figures 6-6 through 6-14 show typical measured insertion loss for each of the seven proposed EIA Loops and the two ETSI Loops.



**Figure 6-6. EIA 1 Insertion Loss Graph**

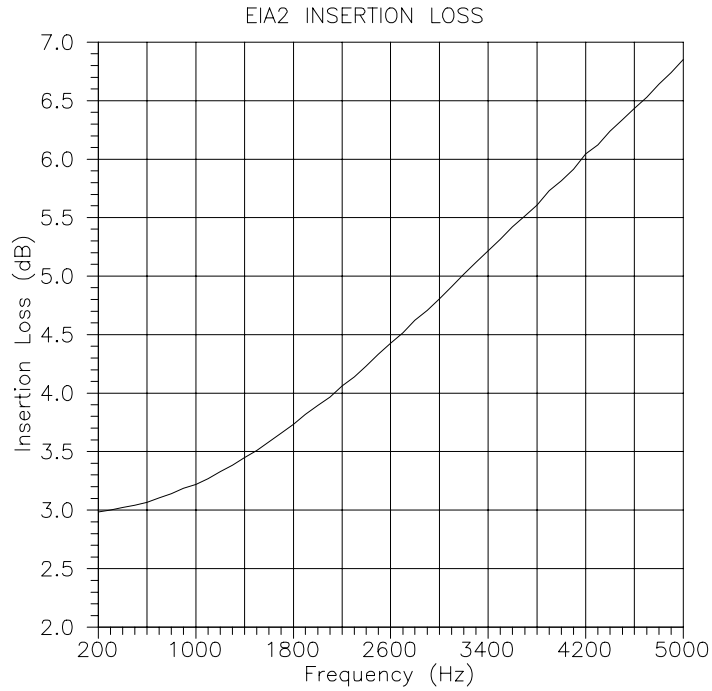

**Figure 6-7. EIA 2 Insertion Loss Graph**

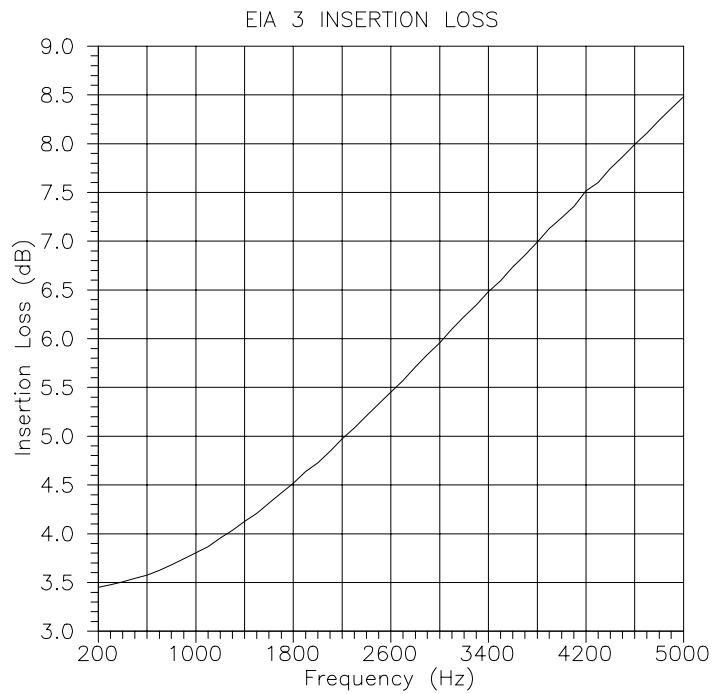

**Figure 6-8. EIA 3 Insertion Loss Graph**

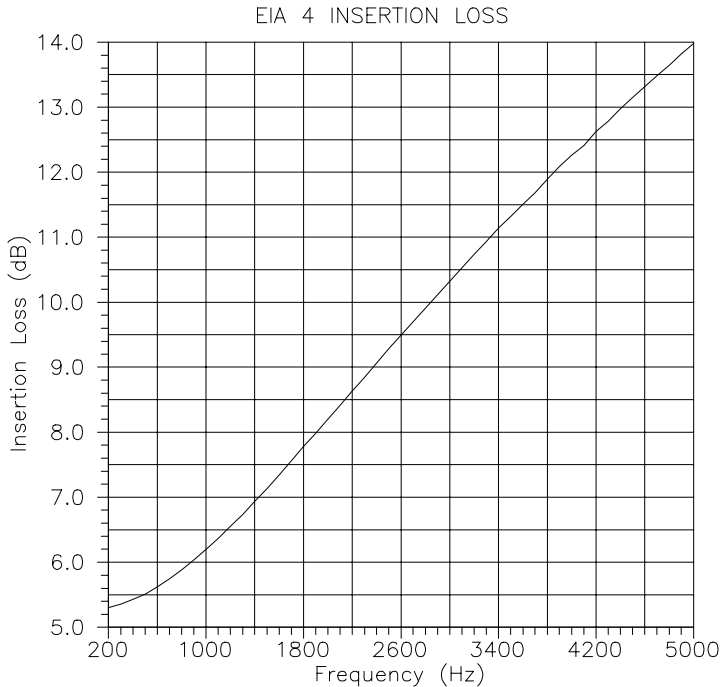

Figure 6-9. EIA 4 Insertion Loss Graph

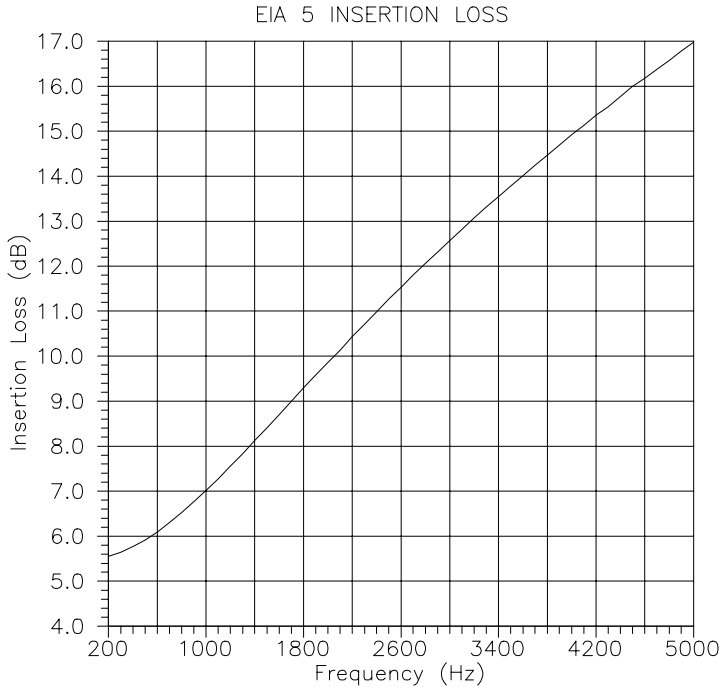
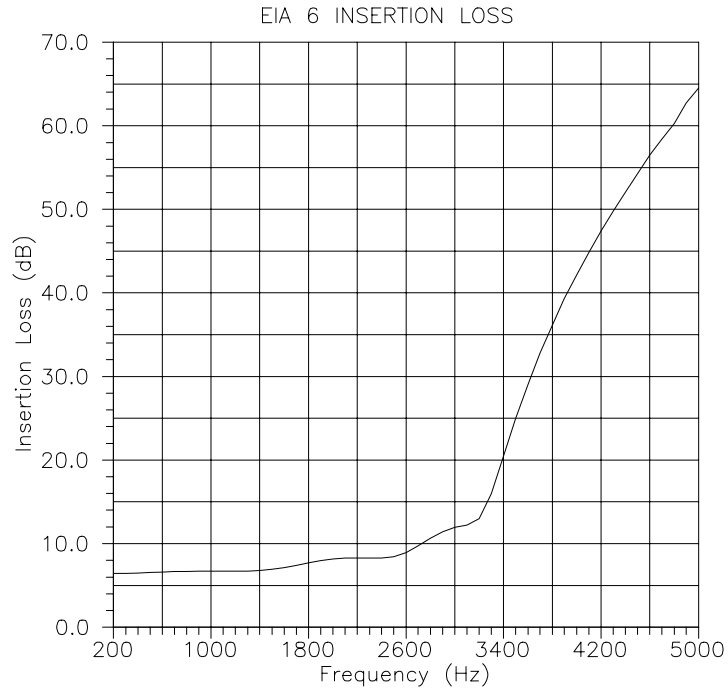
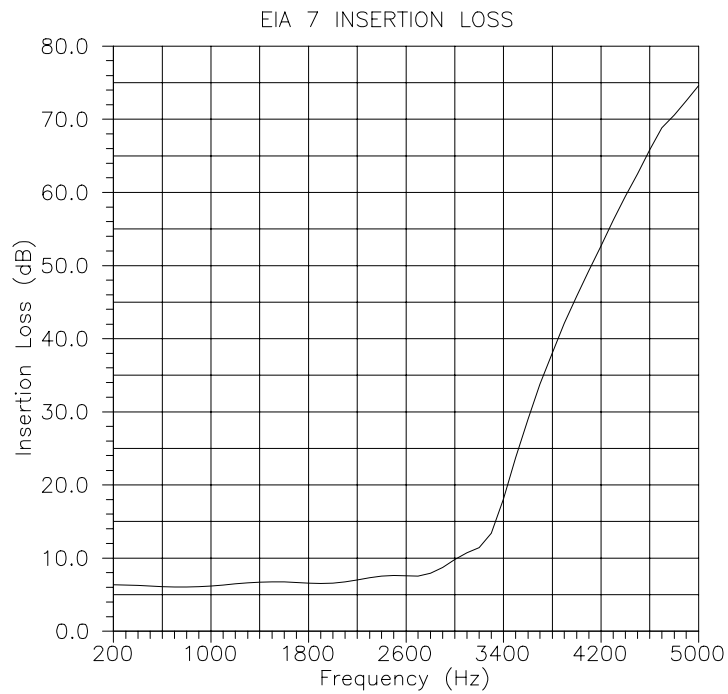

Figure 6-10. EIA 5 Insertion Loss Graph



**Figure 6-11. EIA 6 Insertion Loss Graph**



**Figure 6-12. EIA 7 Insertion Loss Graph**



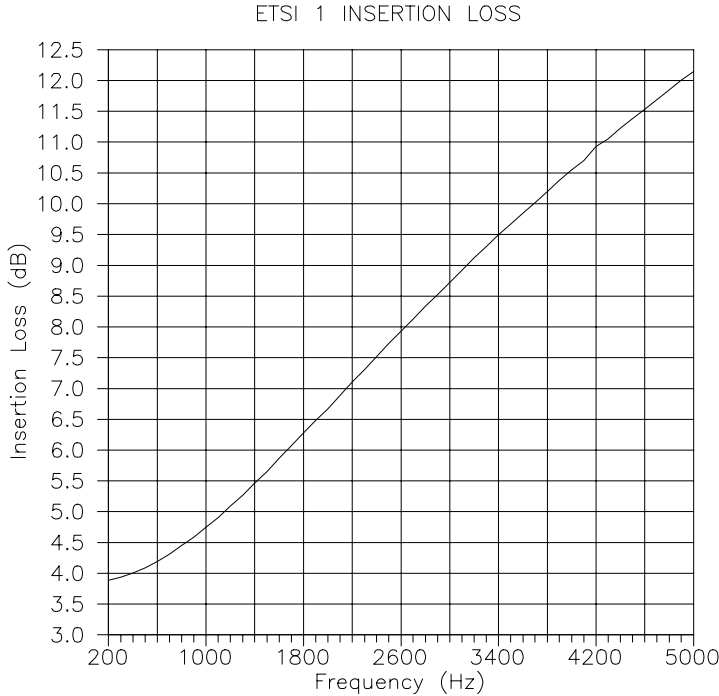

Figure 6-13. ETSI 1 Insertion Loss Graph

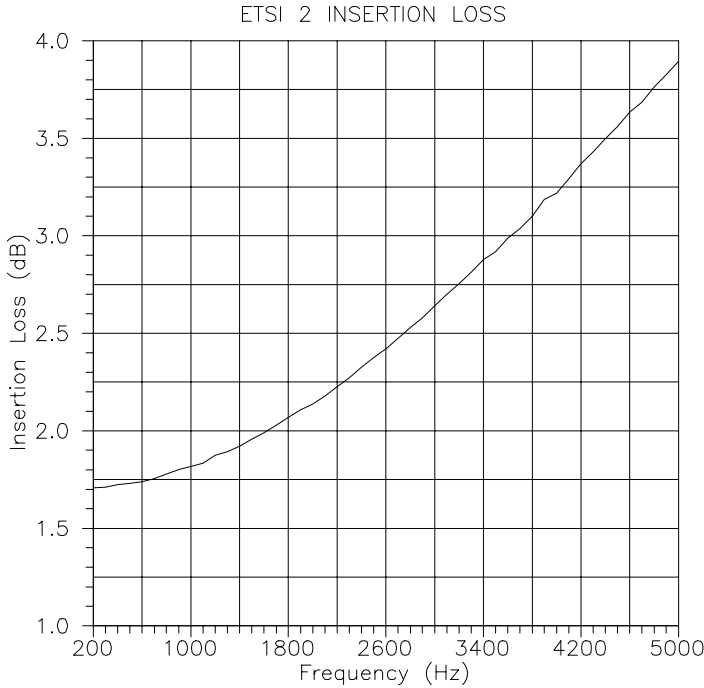

Figure 6-14. ETSI 2 Insertion Loss Graph



## 6.12. Fuse Replacement Procedure

The fuse is installed at the factory to match the most commonly used line voltage in the country of destination.

---

**Caution - Disconnect from the supply before servicing**

---

1. Locate the power entry module on rear panel.
2. Using a small screwdriver, pry open the cover to expose the fuse holder using the notch at the top of the power entry module (refer to diagram below).

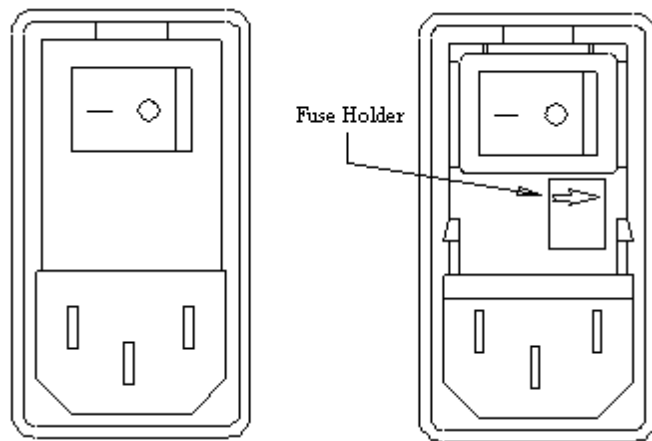

3. Pull the fuse from the fuse holder.
4. To reinstall, select the proper fuse and place in the fuse holder.

TAS Part Number	Type
1800-0078	2A 250V Slow-Blow Fuse

5. Reinsert the fuse holder and close the power entry module.

## 6.13. Impairments

### Multi-Frequency Interference (Option)

Level	
Range	15 to 75 dBm
Resolution	0.1 dB
Accuracy	0.5 dB
Frequency	
Range	50 to 4000 kHz
Resolution	1 Hz
Accuracy	+ 1 Hz

### Noise (Option)

Level	
Range	15 to 50 dBm
Resolution	0.1 dB
Accuracy	0.5 dB
Weighting	3 kHz Flat

### IEEE Impulse Noise (Option)

Level	
Range	30 to 70 dBmC
Resolution	0.1 dB
Accuracy	0.5 dB
Trigger	
Method	Periodic
Period	0.1 to 100 sec
Resolution	0.1 sec

This page intentionally left blank.



---

---

## TAS APPLICATION NOTE #7

---

---

### The Effect of Metering Pulse Interference on Modems & Fax Machines

---

---

This application note explains how to use the TAS 240 Voiceband Subscriber Loop Emulator and the TAS 100 Telephone Network Simulator to test the effects of metering pulse interference on modems and fax machines destined for the European market.

#### Metering Pulse Testing Requirements

The characteristics of metering pulse interference that are typically encountered in Europe depend upon the requirements of the specific country. The test requirements of each country specify a frequency, level and cadence for metering pulses. A TAS 240 equipped with the metering pulse option allows emulation of virtually all the required combinations of frequency, level, and cadence found in Europe.

Table 1 presents a summary of test requirements for several European countries. This data was derived from the ETSI NET 4 standard, except where noted.

The terminology used in Table 1 is defined below.

- F1 - Indicates minimum metering pulse test frequency for country.
- F2 - Indicates maximum metering pulse test frequency for country.
- L1 - Indicates minimum metering pulse test level for country.
- L2 - Indicates maximum metering pulse test level for country.
- Cadence - Indicates the number of milliseconds the pulse should be ON, followed by the number of milliseconds the pulse should be OFF. The data shown may be given as a minimum time (min) or a range (XX +/-Y).

COUNTRY	PARAMETER VALUES					
	F1 (Hz)	F2 (Hz)	L1 (dBm)	L2 (dBm)	Cadence	
					On (msec)	Off (msec)
Belgium	15840	16160	-18	+17	80 (min)	220 (min)
France	11880	12120	-19	+13	125 ± 25	160 (min)
Germany	15920	16080	-22	+22	120	220*
Greece	15250	16500	-18	+18	50	90
Ireland	11880	12100	-25	+9	120 ± 20	120 ± 20
Italy	11880	12120	-21	+8	80	20
Norway	15840	16160	-25	+6	120	220*
Portugal	11880	12120	-13	+15	120	250
Spain	11880	12120		+9	100	500*
Sweden	11940	12060	-14	+22	200-500	90 (min)
Switzerland	11700	12300	-17	+22	50-150	90-10,000

**Table 1. Metering Pulse Parameter Summary**

\* Cadence information derived from ETSI NET 20 Standard.  
(Information reproduced from the requirements of  
the Swiss Post, Telegraph and Telephone (PTT).)

All levels are specified in dBm for a 600 ohm reference load. However since a typical loop impedance is approximately 200 ohms in the 12-16 kHz frequency range, all parameters are specified for a 200 ohm load.

## Test Bench Set Up

Figure 1 shows the basic test set-up that can be used to test either modems or fax machines for sensitivity to metering pulse interference. In this arrangement, all connections to the TAS 240 are made to the rear panel METERING PULSE terminal strip.

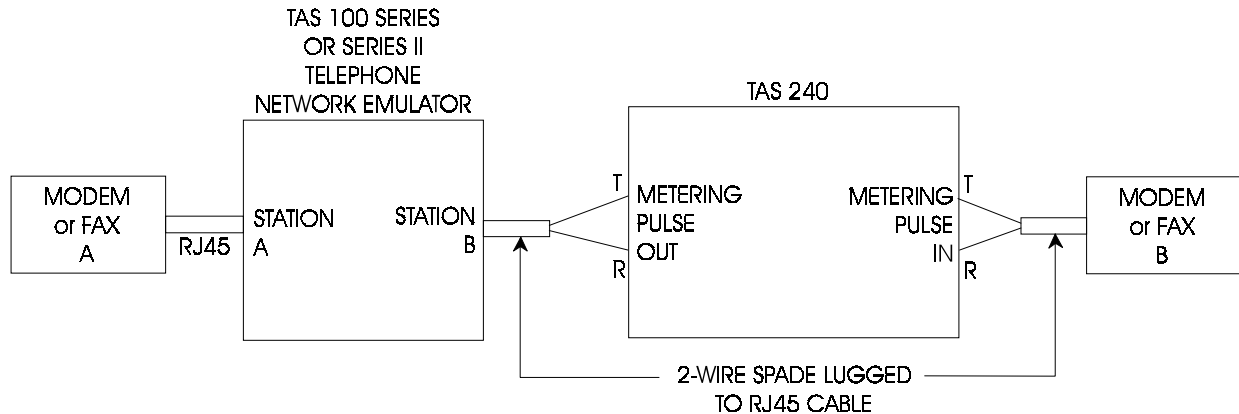

**Figure 1. Basic Test Set-Up**

**NOTE:** The TAS 100 must be connected to the METERING PULSE OUT terminals on the rear panel of the TAS 240. This configuration allows the TAS 240 to protect the input circuitry of the TAS 100 by inserting a blocking filter between the metering pulse generator and the input port of the TAS 100. It is recommended that the unit under test be the originating station for all data calls.

To test a device for sensitivity to a specific country's metering pulse interference, the TAS 100 and the TAS 240 must be set to the proper conditions for that country. It is assumed that the metering pulse testing is performed separately from any other impairment testing. Therefore all network transmission impairments in the TAS 100 will be disabled except for a signal loss of 8dB.

### Modem Testing Issues

The TAS 100 and the TAS 240 are configured for testing modems as shown in Figure 1. By adding a TAS Gemini Dual Terminal Emulator to the test bench, the user can run a bit error rate test to establish the sensitivity of the unit under test to metering pulses. To meet a country's metering pulse requirements, the device under test should yield acceptable results in the presence of metering pulses.

## Fax Testing Issues

The TAS 100 and the TAS 240 are configured for testing fax machines as shown in Figure 1. The user can run a standard image quality test using the CCITT Recommendation T.21 Standardized Test Chart for Document Facsimile Transmission to establish the sensitivity of the unit under test to metering pulses. To meet a country's metering pulse requirements, the device under test should yield acceptable results in the presence of metering pulses.

### Example: Testing to the German Conditions

As an example, use the following steps to configure the test setup to the requirements for German testing.

#### Configuring The TAS 100 Telephone Network Emulator

To configure the TAS 100 for the test using front panel control, the user need only disable all impairments, and select the German central office simulation. This can be done by recalling files stored in the TAS 100.

1. Press the RECALL key. The display will read:

```
RECALL:  CO+IMP           <filename>
```

2. Using the cursor keys, move the cursor to the field to the right, and using the step keys, select FACTORY DEFAULT. This file turns off all impairments. The display will read:

```
RECALL:  CO+IMP           factory default
```

3. Press RECALL key again to recall factory default setting. Display will confirm choice.

```
RECALLED from factory default
```

4. Press RECALL key again. The display will read:

```
RECALL:  CO+IMP           factory default
```

5. Using the CURSOR keys, move the cursor back to the field on the left, and using the STEP keys, select CO ONLY. This will allow choice of the German central office parameters, while leaving the impairments off. The display will read:

```
RECALL:  CO only           factory default
```



- Using the CURSOR keys, move the cursor back to the field on the right, and using the STEP keys, select GERMANY. The display will read:

```
RECALL: CO only      Germany
```

- Press RECALL key again to recall German central office setting. Display will confirm choice.

```
RECALLED from Germany
```

### Configuring the TAS 240 Metering Pulse Generator

To configure the TAS 240 to simulate metering pulses, the user need only select the metering pulse frequency, level, cadence on time, cadence off time, and port. These are all selected using the front panel menus.

- To start, select METERING PULSES from the main menu. Then press the ENTER key.
- The display will show one of the metering pulse menus. Using the PLUS (+) and MINUS (-) keys, scroll through the menus to find the FREQUENCY menu. The display will read:

```
frequency ↵  
+/- selects metering pulse menu
```

- Press the ENTER key to see the frequency currently selected. The display will read:

```
FREQUENCY: XX.XX kHz  
+/- selects frequency
```

- Since German metering pulse simulation is desired, the FREQUENCY as shown in TABLE 1 must be from 15920 Hz to 16080 Hz. Using the PLUS and MINUS keys, raise or lower the frequency currently shown to the desired value (16000 Hz). The display will read:

```
FREQUENCY: 16.00 kHz  
+/- selects frequency
```

- Press the ESC key to return to the previous menu level. Press the PLUS key to move to the LEVEL menu. The display will read:

```
level ↵  
+/- selects metering pulse menu
```

6. Press the ENTER key to see the level currently selected. The display will read:

```
LEVEL: XX dBm
+/- selects level
```

7. The level must be in the range from -22 dBm to +22 dBm. The user may elect to set the highest level immediately, for a worst case test, or may set a lower level initially, and increase it to the maximum. Using the PLUS and MINUS keys, select the desired level (0dBm). The display will read:

```
LEVEL: 0 dBm
+/- selects level
```

8. Press the ESC key to return to the previous menu level. Press the PLUS key to move to the ON TIME menu. The display will read:

```
on time ↵
+/- selects metering pulse menu
```

9. Press the ENTER key to see the on time currently selected. The display will read:

```
ON TIME: X.XXX seconds
+/- selects interval
```

10. The on time for the German test will be that specified by the ETSI NET 20 Standard. Using the PLUS and MINUS keys, select 120 msec as the on time. The display will read:

```
ON TIME: 0.120 seconds
+/- selects interval
```

11. Press the ESC key to return to the previous menu level. Press the PLUS key to move to the OFF TIME menu. The display will read:

```
off time ↵
+/- selects metering pulse menu
```

12. Press the ENTER key to see the off time currently selected. The display will read:

```
OFF TIME: X.XXX seconds
+/- selects interval
```

13. The off time for the German test will be that specified by the ETSI NET 20 Standard. Using the PLUS and MINUS keys, select 220 msec as the off time. The display will read:

```
OFF TIME: 0.220 seconds
+/- selects interval
```

14. Press the ESC key to return to the previous menu level. Press the PLUS key to move to the SOURCE IMPEDANCE menu. The display will read:

```
source impedance ↵
+/- selects metering pulse menu
```

15. Press the ENTER key to see the source impedance currently selected. The display will read:

```
SOURCE IMPEDANCE: XXX ohms
+/- selects impedance
```

16. A source impedance of 0 ohms will present the highest level of metering pulses to the load. Setting the source impedance to any other value will cause a reduced level of the signal to reach the device under test due to the voltage divider formed between the source impedance and the load impedance. Using the PLUS and MINUS keys, set the source impedance to 0 ohms. The display will read:

```
SOURCE IMPEDANCE: 0 ohms
+/- selects impedance
```

17. Press the ESC key to return to the previous menu level. Press the PLUS key to move to the GENERATOR menu. The display will read:

```
generator ↵
+/- selects metering pulse menu
```

18. Press the ENTER key to see the status of the metering pulse generator and the port currently selected. The display will read:

```
SIGNAL: XXX          PORT: XXX
+/- selects port    Enter changes field
```

19. The metering pulse generator must be turned on using the SIGNAL field. Using the ENTER key, move the blinking cursor to the SIGNAL field. Then using the PLUS and MINUS keys, select ON from the menu. The display will read:

```
SIGNAL: ON          PORT: XXXX
+/- selects state   Enter changes field
```

20. Since the test setup makes all connections to the rear panel, the port selected must be the rear panel. Using the ENTER key, move the blinking cursor to the PORT field. Then using the PLUS and MINUS keys, select REAR from the menu. The display will read:

```
SIGNAL: ON          PORT: REAR
+/- selects port    Enter changes field
```

**NOTE:** The TAS 240 is now fully configured. To establish the voltage level desired across the device under test, the TAS 240 must be calibrated. Prior to calibration, the device under test must be taken off hook, so that its input impedance will be the same as during normal operation of the device. A calibration may also be performed after a data call or fax transmission has been established. The calibration procedure may cause the call to be dropped by devices that are sensitive to the metering pulse signal. If this occurs, turn off the metering pulse generator using the SIGNAL field in the GENERATOR menu, reestablish the call, and turn the metering pulse generator back on. The calibrated level will still be present.

**CAUTION:** The metering pulse generator must not be connected at the answering station during call setup. The ringing voltage may damage the test setup. If the unit under test must be the answering station, perform the call setup before turning on the metering pulse generator.

21. Press the ESC key to return to the previous menu level. Press the MINUS key to move to the CALIBRATE menu. The display will read:

```
calibrate ↵
+/- selects metering pulse menu
```

22. Take the device under test off hook. Most often this is done by setting up a data call. Some devices may have commands that will take them off hook without a call being placed.
23. Press the ENTER key to go to the calibration menu. Press the ENTER key again to begin calibration. A successful calibration will be indicated by returning to the previous display.

24. If a data call was set up prior to calibration, and was dropped as a result of calibration, turn off the metering pulse generator using the SIGNAL field in the GENERATOR menu, reestablish the call, and turn the metering pulse generator back on. The calibrated level will still be present.

At this point the user can begin the BERT, or image quality test to judge the performance of the device under test.

To test a device with the conditions of another country, simply repeat the steps above for configuring the TAS 100 and the TAS 240, while substituting the requirements of the new country for the German requirements given.

The calibration must be repeated whenever the device under test, the port, or the frequency is changed.

### **Calibration Error**

If calibration should fail, as indicated by a calibration error display, it indicates that there may be a problem with the setup. Check all connections on the rear of the TAS 240.

If the connections appear correct, the calibration error may indicate that the impedance of the device under test is incompatible with the level set. This is possible if a device has a low impedance (under 100 ohms), and a high level is set, or if a device has a high impedance (above 1600 ohms), and a low level is set.

Adjust the level to a median value (0 dBm) and recalibrate. If the calibration is successful, try raising (or lowering) the level 1 dB at a time until it fails. This indicates the upper (or lower) limit of the metering pulse level that can be attained for the device under test.

This page intentionally left blank.

## **APPENDIX A: TAS 240 METERING PULSES (OPTION)**

---

### **A.1. Introduction**

Metering pulses are used to transmit billing information for telephone service in European countries. These pulses consist of an out-of-band (12 kHz-16 kHz) tone that is generated with a repetitive cadence (on/off period).

The TAS 240 Voiceband Subscriber Loop Emulator (VSLE) accurately simulates metering pulse interference required by European government telephone administration acceptance tests. The metering pulse generator can be used standalone or in conjunction with the VSLE's subscriber loops to evaluate modems according to ETSI Net 20 specifications.

For tests that include the TAS 240's local loop emulator, the generator can be connected to either the End Office (EO) or Network Interface (NI) end of the VSLE's main subscriber loops. When used alone, without local loop simulation, the metering pulse generator is connected to a convenient terminal block on the rear panel of the unit.

### A.1.1. System Description

The TAS 240 Voiceband Subscriber Loop Emulator (VSLE), when equipped with a metering pulse generator, provides programmable level, frequency, cadence, and source impedance simulation to comply with the requirements of European telephone administration's modern homologation tests. Used with either a TAS Series II or TAS 100 Series Telephone Network Emulator, the TAS 240's metering pulse generator can be used standalone, or with local loop emulation.

For applications that include local loops, a telephone network emulator is connected to the EO ends of the loops, and modems are connected to the NI ends. The metering pulse generator can then be applied across either the EO or NI end of the main loop.

For applications without local loops, a telephone network emulator is connected to the METERING PULSE OUT terminal on the rear panel and the modem or external loop is connected to the METERING PULSE IN terminal. In this case, the RJ45 connectors and terminal strips designated for connection to subscriber loops A and B are not used.

The presence of a high level metering pulse signal could potentially saturate the input level circuitry of the telephone network emulator. Therefore, the TAS 240 provides a metering pulse blocking filter in the path between the generator and the network emulator.

When the metering pulse generator is being used in conjunction with the VSLE's local loops, the blocking filter is placed in series after the EO end of the main loops as shown in Figure A-1.

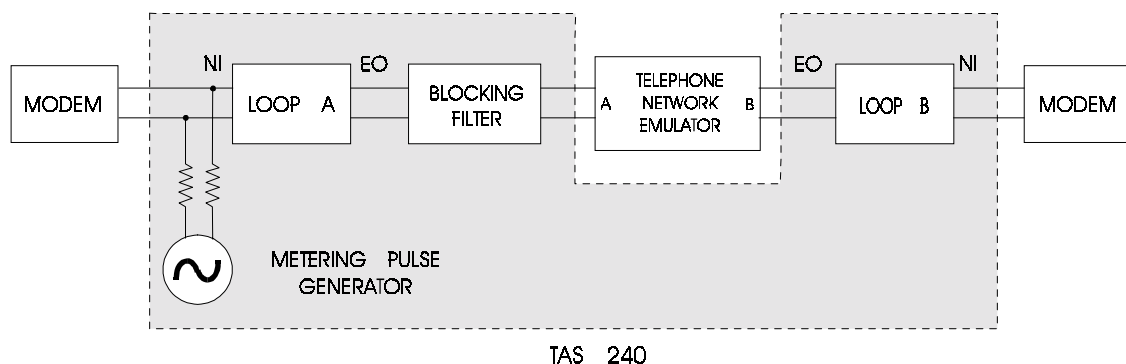

**Figure A-1. Connecting the Metering Pulse Generator to Loop A**



For the case when the metering pulse generator is switched directly to the METERING PULSE terminal block on the rear panel, the blocking filter is placed between the generator and the METERING PULSE OUT terminal as shown in Figure A-2.

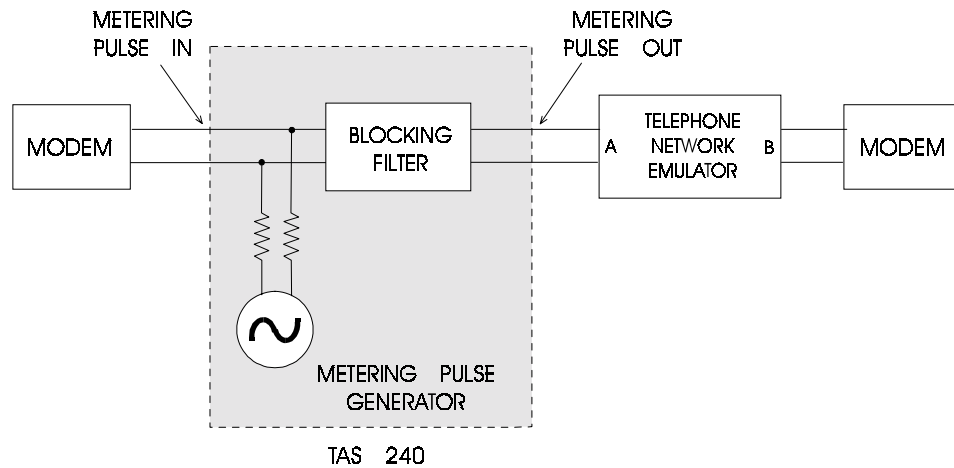

**Figure A-2. Connecting the Metering Pulse Generator to the METERING PULSE Terminal Block on the Rear Panel.**

This filter prevents the metering pulse signal from leaving the A1EO, B1EO, or the METERING PULSE OUT ports of the VSLE. This filter has negligible insertion loss, and an input impedance of approximately 600 ohms in the voiceband.

## A.2. Operating the Metering Pulse Generator

The TAS 240 VSLE emulates metering pulses using a tone generator with programmable level, frequency, cadence, and source impedance. A block diagram of the VSLE's metering pulse generator is shown in Figure A-3.

**NOTE:** This block diagram is a functional description of the generator and does not depict the actual implementation.

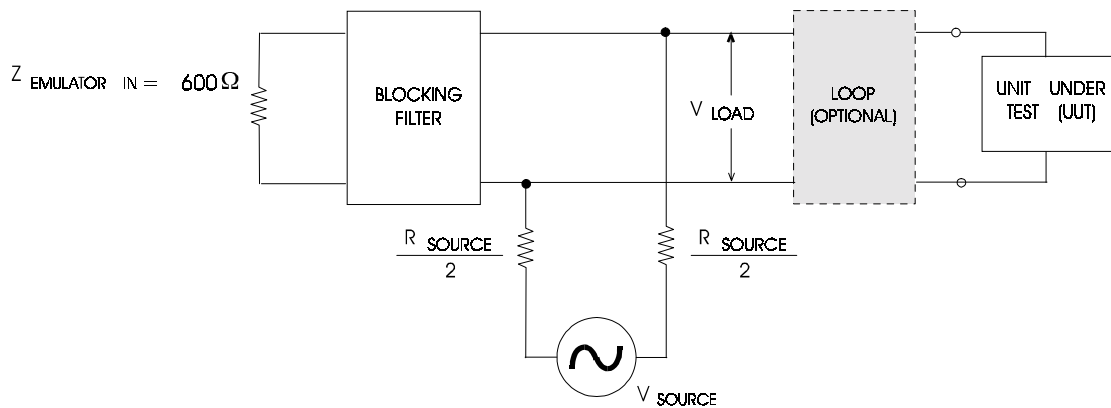

**Figure A-3. Metering Pulse Generator Block Diagram**

To accurately provide the desired level across the load, the generator is implemented using a voltage-controlled constant current source. The load consists of the unit under test (UUT) and an optional loop. Since the generator is a current source, it is necessary for the TAS 240 to perform a brief calibration to calculate the current needed to develop the desired voltage across the load present.

### A.2.1. Calibration

The metering pulse generator output power is specified for a 600 ohm reference from a level of -28 dBm (31 Vrms) to 23 dBm (10.95 Vrms). The output power is referenced to 600 ohms since most measurement instruments have a 600 ohm input impedance. However, since a typical loop impedance is approximately 200 ohms in the 12-16 kHz frequency range, all metering pulse generator parameters are specified for a 200 ohm load.

The complex impedance that will accurately be present across the output of the generator will vary with the user supplied equipment (modem and/or subscriber loop), the application point (port) and the frequency of the metering pulse signal. The calibration operation allows the metering pulse generator to measure the load present at the port, and adjust its output to match the level selected.

When a calibration is performed, a 1 mA calibration current is passed through the load. After the voltage generated across the load is measured, the impedance of the load is calculated and used in later computations.

Thus any time a change to the test setup is made that affects the load seen by the generator, a calibration must be performed. These include:

- Change of external load (modem and/or subscriber loop)
- Change of metering pulse port, or application point
- Change in metering pulse frequency

To guarantee the desired level is always present across the load, a calibration should be performed after changing any metering pulse generator parameter. If the generator cannot provide the desired level across the effective load a calibration error will be reported.

### A.2.2. Source Impedance

The metering pulse generator can be programmed to simulate a source of impedance of 0, 50, 100, 150, or 200 ohms. The source impedance selected will determine what fraction of the metering pulse level appears across the load. For the source impedance to be valid, a calibration must be performed. To best illustrate the effect of source impedance, the following examples are provided.

Figure A-4 shows the source impedance of the metering pulse generator set to 0 ohms, with “Null” loop selection. In this example the entire programmed metering pulse level appears across the UUT. If the generator level is set to 10 dBm (2.45 Vrms), a level of 10 dBm will be present across the UUT.

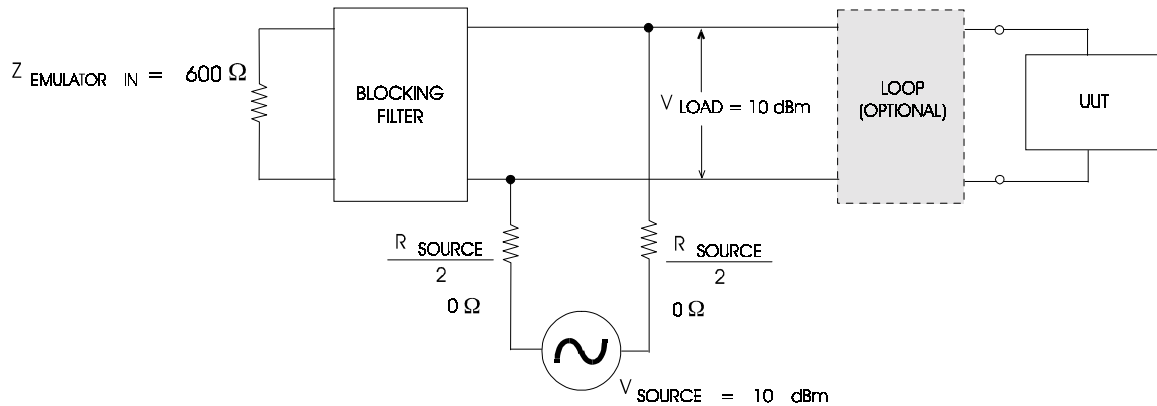

**Figure A-4. Example 1: Source Impedance = 0 ohms**

Figure A-5 illustrates the source impedance of the metering pulse generator set to a non-zero value, 200 ohms in this example. Only a fraction of the metering pulse level set appears across the load. The simulated source impedance of the generator has the effect of a voltage divider. With a “Null” loop selection, a source impedance of 200 ohms and a load of 200 ohms, half of the metering pulse level set will be seen across the load. For example, with an equivalent load of 200 ohms and the generator level set to 10 dBm (2.45 Vrms), a level of 4 dBm (1.228 Vrms) will be present across the load.

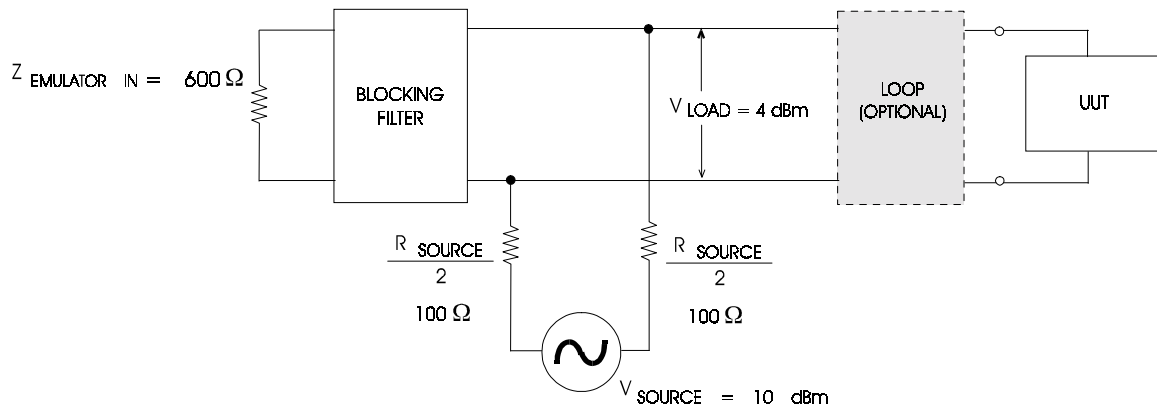

**Figure A-5. Example 2: Source Impedance = 200 ohms**

### A.3. Setup

Used as part of a TAS Automatic Modem Test System, the TAS 240 VSLE is a completely integrated solution for testing a modem's susceptibility to metering pulse interference and ability to perform echo cancellation. A typical test setup that utilizes the TAS 240's metering pulse generator and local loop emulation is shown in Figure A-6. Refer to Section 1.5 of this manual for detailed installation instructions.

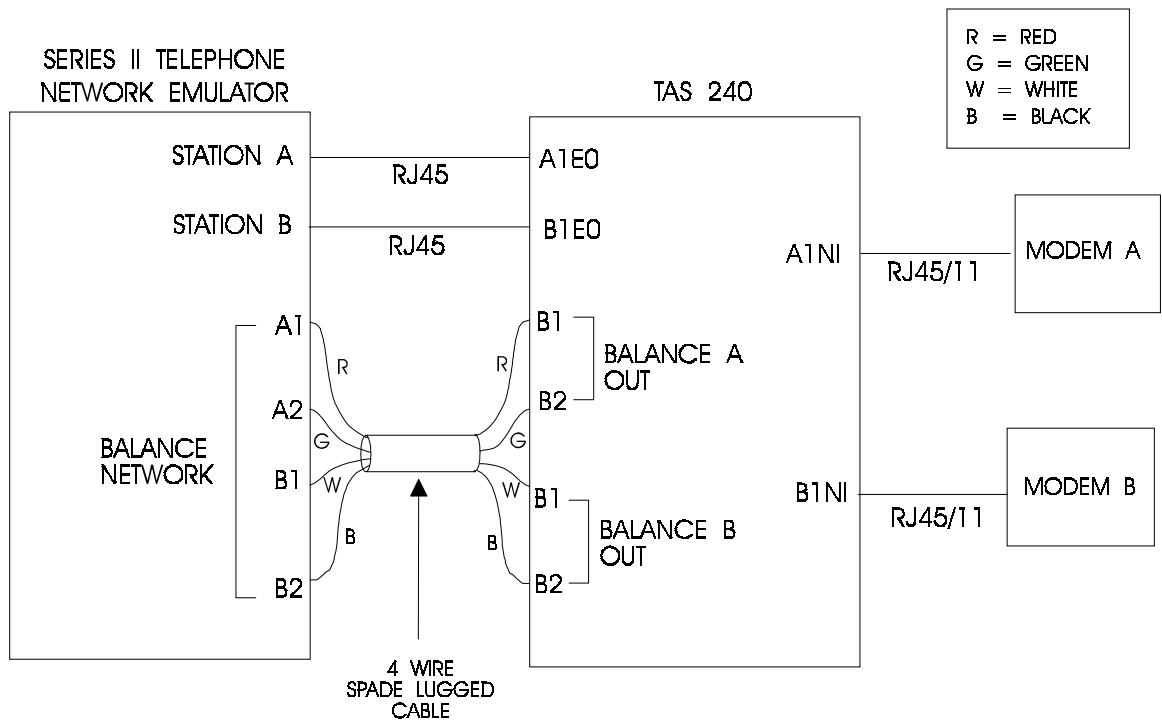

**Figure A-6. Typical Signal Interconnection Using Metering Pulse Generator with Local Loop Emulation**

Figure A-7 shows a test setup using only the metering pulse generator.

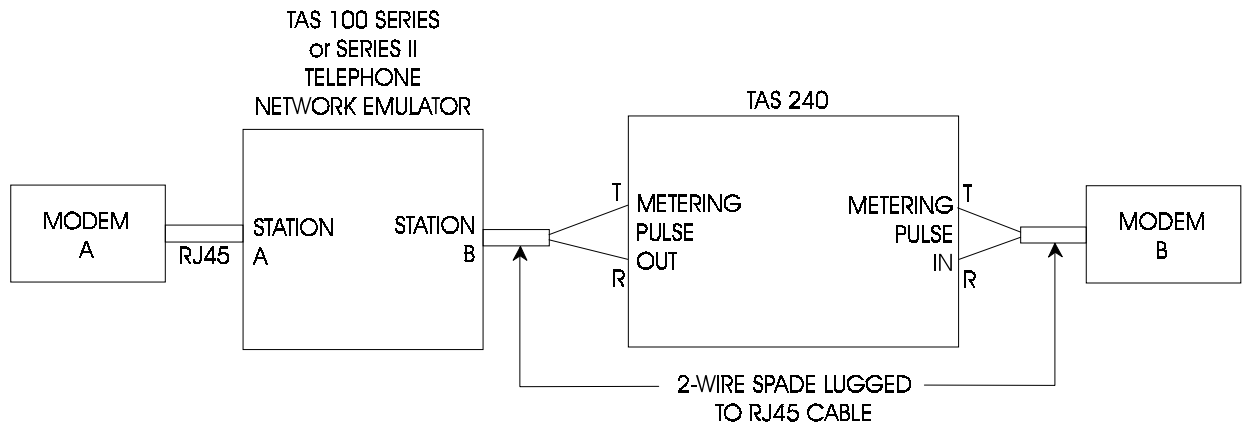

**Figure A-7. Typical Signal Interconnection Using Metering Pulse Generator Only**

The following connections must be made to connect the metering pulse generator through the terminal block of the TAS 240 to a Telephone Network Emulator.

1. Connect Network Emulator station A to modem A (using an RJ-45 cable).
2. Connect Network Emulator station B to the TAS 240 Metering Pulse Out through RJ-45 to 2-wire spade-lugged cable.
3. Connect TAS 240 Metering Pulse into modem B through RJ-45 to 2-wire spade-lugged cable.

The metering pulse generator may be configured using the front panel menus or remote commands. To configure the generator, the following parameters should be set:

1. Turn the metering pulse signal on.

**WARNING:** The metering pulse generator must not be applied at the answering station during call setup. The ringing voltage may damage the test setup. If the unit under test is the answering station, the metering pulse generator must be turned off during call setup. To do this:

- a) Turn the signal parameter off.
- b) Perform the call setup.
- c) Turn the generator back on.

2. Select the desired frequency from 11.5 kHz to 16.5 kHz.
3. Select the desired cadence by selecting an on time from 20 msec to 1 sec, and an off time from 0 msec to 1.5 sec.
4. Select the desired level from -28 dBm (referenced to 600 ohms) to 23 dBm (referenced to 600 ohms).
5. Set source impedance to desired value from 0 ohms to 200 ohms.
6. Select the port that the generator is to be connected to. If the metering pulse generator is being used along with subscriber loop emulation, select the desired local loop.
7. Put modem in off-hook state.
8. Calibrate the metering pulse generator.

As mentioned earlier, for the metering pulse generator to provide an accurate level it is important that a calibration be performed after setting up all of the generator parameters. The metering pulse generator is not calibrated at power-up. Please see the calibration section for additional details on this procedure.

To provide an accurate representation of the test load impedance, the modem present at the load of the metering pulse generator should be put in the off-hook state before calibrating. A calibration procedure may also cause the data call to be dropped by modems that are sensitive to the metering pulse signal. If this occurs, reestablish the data call.

Refer to the Local Operation section and the Remote Commands section for additional information on each metering pulse parameter.



## A.4. Local Operation

The front panel menu selections for the metering pulse generator are illustrated in Figure A-8.

generator ↵ +/- selects menu
frequency ↵ +/- selects menu
level ↵ +/- selects menu
on time ↵ +/- selects menu
off time ↵ +/- selects menu
source impedance ↵ +/- selects menu
calibrate ↵ +/- selects menu

**Figure A-8. Select Metering Pulse Parameters**

Figure A-9 shows the generator menu. The SIGNAL selection turns the metering pulse generator on and off. Pressing ENTER changes the menu field and allows the selection of the metering pulse port, as shown in Figure A-10.

SIGNAL: ON	PORT: A1E0
+/- selects state	Enter changes field

**Figure A-9. Turn On Metering Pulse Generator**

Figure A-10 shows the port selection for the point at which the metering pulse is injected. The metering pulse can be injected at either end of the main loop A or B, or at the METERING PULSE IN terminal on the rear panel. The selections are A1EO, A1NI, B1EO, B1NI, and REAR.

SIGNAL: ON	PORT: <b>A1EO</b>
+/- selects port	Enter changes field

**Figure A-10. Select Metering Pulse Port**

Figure A-11 shows the frequency selection for the metering pulse which covers the range from 11.5 kHz to 16.5 kHz. In the range from 11.5 kHz to 13.0 kHz, and from 15.0 kHz to 16.5 kHz, the frequency may be changed in 10 Hz steps from the front panel. From 13.0 kHz to 15.0 kHz, the frequency may be changed in 500 Hz steps from the front panel.

FREQUENCY: <b>11.50</b> kHz
+/- selects frequency

**Figure A-11. Select Metering Pulse Frequency**

Figure A-12 shows the level selection for the metering pulse which covers the range from -28 dBm (referenced to 600 ohms) to 23 dBm (referenced to 600 ohms) in 1 dBm steps.

LEVEL: <b>10</b> dBm
+/- selects level

**Figure A-12. Select Metering Pulse Level**

Figure A-13 shows the on time selection for the metering pulse which covers the range from 20 msec to 1 sec in 0.02 sec (20 msec) steps.

ON TIME: <b>0.020</b> seconds
+/- selects interval

**Figure A-13. Select Metering Pulse On Time**

Figure A-14 shows the off time selection for the metering pulse which covers the range from 0 msec to 1.5 sec in 0.02 sec (20 msec) steps.

OFF TIME: <b>0.000</b> seconds
+/- selects interval

**Figure A-14. Select Metering Pulse Source Impedance**

Figure A-15 shows the source impedance selection for the metering pulse which covers the values 0, 50, 100, 150, and 200 ohms. Please see the Source Impedance section for an explanation of the effect of source impedance on the output level.

```
SOURCE IMPEDANCE: 200 ohms
+/- selects impedance
```

**Figure A-15. Select Metering Pulse Source Impedance**

The calibration menu is shown in Figure A-16. The calibrate function allows the metering pulse generator to provide the correct output level across the load present at the selected port. To guarantee the proper level is present at the load, a calibration should be performed each time a metering pulse generator parameter is changed. Please see the Calibration section for additional details on this procedure.

```
METERING PULSE CALIBRATION
Press Enter to calibrate  ESC to return
```

**Figure A-16. Calibrate Metering Pulse Generator**

## A.5. Remote Commands

### Command Group Format

```
/METER: SIGNAL=XXX, FREQ=FF.FF, LEVEL=VV, ON=NN.NN,  
OFF=OO.OOO, PORT=SSS, IMPED=III, CAL/
```

### Command Group Description

The METER command allows the user to program all parameters associated with the metering pulse generator including level, frequency of the pulse waveform, cadence, source impedance, and port. The calibration command can also be performed using remote operation.

### Command Description

The SIGNAL command turns the metering pulse generator on or off.

Command: /METER:SIGNAL=xxx/  
Response: /C/

'xxx' can be either ON or OFF.

The FREQ command specifies the frequency of the metering pulse generator waveform.

Command: /METER:FREQ=ff.ff/  
Response: /C/

'ff.ff' selects the frequency in kilohertz in the range from 11.50 kHz to 16.50 kHz in .01 kHz (10 Hz) steps.

The LEVEL command specifies the output level of the metering pulse generator waveform.

Command: /METER:LEVEL=vv/  
Response: /C/

'vv' selects the level in dBm in the range from -28 dBm (relative to 600 ohms) to 23 dBm (relative to 600 ohms) in 1 dBm steps.

The ON command specifies the on time for the cadence signal.

Command: /METER:ON=nn.nnn/

Response: /C/

'nn.nnn' selects the on time in the range from 0.005 sec (5msec) to 30.000 sec in 0.005 sec (5 msec) steps.

The OFF command specifies the off time for the cadence signal.

Command: /METER:OFF=oo.ooo/

Response: /C/

'oo.ooo' selects the off time in the range from 0.000 sec to 30.000 sec in 0.005 sec (5msec) steps.

The PORT command specifies the main pair to which the metering pulses will be switched, or connects the metering pulse generator directly to the rear panel.

Command: /METER:PORT=ssss/

Response: /C/

'ssss' selects the connection from the following list:

A1EO	Connects to EO end of pair A1
A1NI	Connects to NI end of pair A1
B1EO	Connects to EO end of pair B1
B1NI	Connects to NI end of pair B1
REAR	Connects the generator to rear panel terminate block

The IMPED command specifies a user-programmable source impedance for the metering pulse generator.

Command: /METER:IMPED:=iii/

Response: /C/

'iii' is chosen from the following list:

0	0 ohms
50	50 ohms
100	100 ohms
150	150 ohms
200	200 ohms

The CAL command initiates a level calibration for the load currently present.

Command: /METER:CAL/

Response: /C/

## A.6. Metering Pulse Technical Specifications

### Frequency

Range:	11.5 kHz - 16.5 kHz
Resolution:	Front Panel: 10 Hz (11.5 kHz - 13.0 kHz, 15.0 kHz - 16.5 kHz) 500 Hz (13.0 - 15.0 kHz) Remote: 10 Hz
Accuracy:	+/- .01 %

### Cadence

#### *On Time*

Range:	Front Panel: 20 msec - 1.000 sec Remote: 20 msec - 30.00 sec
Resolution:	Front Panel: 20 msec Remote: 5 msec
Accuracy:	+/- 1%

#### *Off Time*

Range:	Front panel: 0 msec - 1.500 sec Remote: 0 msec - 30.000 sec
Resolution:	Front panel: 20 msec Remote: 5 msec
Accuracy:	+/- 1%

### Level

Range:	-28 dBm to 23 dBm (referenced to 600 ohms)
Resolution:	1 dBm
Accuracy:	+/- 1 dBm
Maximum Load Current:	100 mA

### Source Impedance (Simulated)

Range:	0 ohms to 200 ohms
Resolution:	50 ohms
Accuracy:	+/- 5%

<b>dBm (600Ω)</b>	<b>Vrms</b>	<b>dBm (600Ω)</b>	<b>Vrms</b>
23	10.947	-1	0.691
22	9.760	-2	0.616
21	8.696	-3	0.549
20	7.750	-4	0.489
19	6.907	-5	0.436
18	6.156	-6	0.388
17	5.487	-7	0.346
16	4.890	-8	0.309
15	4.358	-9	0.275
14	3.884	-10	0.245
13	3.462	-11	0.218
12	3.085	-12	0.195
11	2.750	-13	0.174
10	2.451	-14	0.155
9	2.184	-15	0.138
8	1.947	-16	0.123
7	1.735	-17	0.110
6	1.546	-18	0.098
5	1.378	-19	0.087
4	1.228	-20	0.078
3	1.095	-21	0.069
2	0.976	-22	0.062
1	0.870	-23	0.055
0	0.775	-24	0.049
		-25	0.044
		-26	0.039
		-27	0.035
		-28	0.031

**Table A-1. dBm (600Ω) to Voltage (Vrms) Conversion Chart**