

**Spirent Communications  
TAS Series II  
Telephone Network Emulator  
Operations Manual**

Spirent Communications of Eatontown  
541 Industrial Way West  
Eatontown, NJ 07724

Phone:(732) 544-8700

Fax:(732) 544-8347

This manual applies to TAS Series II 2.7 and higher

Page Part Number: 2700-2003, Version 2.50

Copyright © 2001, Spirent Communications of Eatontown, L.P.

Printed in the USA.

Information furnished by Spirent Communications is believed to be accurate and reliable. However, no responsibility is assumed by Spirent Communications for its use. Specifications are subject to change without notice.
--

## **ABOUT THIS MANUAL...**

---

The TAS Series II Telephone Network Emulators Operations Manual contains information required to effectively use the TAS Series II Telephone Network Emulator. It is recommended that you familiarize yourself with this manual before attempting to use the TAS Series II unit. This manual is presented as follows:

*Section 1 Introduction* - provides a brief description of the Series II including the features and applications, overviews of the front and rear panel, and an installation procedure with a contact telephone number in case you encounter difficulty.

*Section 2 Features Description* - discusses the functions of the various displays, controls, jacks, and ports located on the front and rear panels. All available impairments and allowable network configurations are also fully presented. The optional PCM/ADPCM modules are also presented in this section.

*Section 3 Programmer's Guide* - provides the necessary information to control the TAS Series II via RS-232C or GPIB (IEEE-488) interfaces. This section is essential reading for those who will be integrating a TAS Series II into a larger test system.

*Section 4 Error Codes* - lists the TAS Series II error codes that may be encountered during power-up or operation.

*Section 5 Technical Specifications* - contains detailed system specifications, connector pinouts, and frequency response plots.

This page intentionally left blank.

**TABLE OF CONTENTS**

---

- About This Manual ..... iii**
- 1.0. Introduction..... 1-1**
  - 1.1. Overview ..... 1-1
  - 1.2. TAS Series II Applications..... 1-3
    - 1.2.1. Modem Evaluation and Test ..... 1-3
    - 1.2.2. Fax Evaluation and Test ..... 1-5
    - 1.2.3. Transmission Test Set Evaluation ..... 1-6
    - 1.2.4. Communication Software Evaluation ..... 1-7
    - 1.2.5. Credit Card Verification Terminal Evaluation ..... 1-7
  - 1.3. TAS Series II Major Features ..... 1-8
    - 1.3.1. Bi-directional Analog Impairments ..... 1-8
    - 1.3.2. Bi-directional Digital Impairments ..... 1-10
    - 1.3.3. Selectable Test Channel Configurations ..... 1-10
    - 1.3.4. Advanced Echo Simulation Capability ..... 1-11
    - 1.3.5. Comprehensive Central Office Emulation..... 1-11
    - 1.3.6. Extensive Signal Measurement and Monitoring Capabilities ..... 1-11
    - 1.3.7. Build-In Network Status Monitor ..... 1-11
    - 1.3.8. Advanced System Architecture..... 1-12
  - 1.4. Guided Tour ..... 1-13
    - 1.4.1. Front Panel Overview ..... 1-13
    - 1.4.2. Rear Panel Overview ..... 1-14
  - 1.5. Getting Started..... 1-16
    - 1.5.1. Installation..... 1-16
  - 1.6. Quick Start-up Procedure..... 1-18
    - 1.6.1. Software Control with RS-232 ACK/NAK Interface ..... 1-19
    - 1.6.2. User Software Control with IEEE-488..... 1-20
    - 1.6.3. In Case of Trouble ..... 1-20
  - 1.7. Feature Release History ..... 1-22
    - 1.7.1. Version 2.31 Features ..... 1-22
    - 1.7.2. Version 2.20 Features ..... 1-22
    - 1.7.3. Version 2.10 Features ..... 1-22

1.7.4. Version 2.02 Features .....	1-22
1.7.5. Version 2.00 Features .....	1-22
1.7.6. Version 1.30 Features .....	1-23
1.7.7. Version 1.21 Features .....	1-23
1.7.8. Version 1.20 Features .....	1-24
1.7.9. Version 1.10 Features .....	1-24
1.8. Series II Options.....	1-25
1.8.1. Universal Central Office Emulation .....	1-25
1.8.2. Summary of Major UCO Features .....	1-25
1.8.3. PCM/ADPCM Module .....	1-26
1.8.4. Extended PCM/ADPCM Module .....	1-27
1.8.5. Cellular Audio Processor (CAP) Module.....	1-27
1.8.6. Channel Access Module .....	1-28
1.8.7. Line Interface Adapter .....	1-28
1.9. Companion Products.....	1-29
1.9.1. TAS Gemini Dual Terminal Emulator.....	1-29
1.9.2. TAS 3508A Modem Test Switch.....	1-30
1.9.3. TAS 240 Voiceband Subscriber Loop Emulator .....	1-30
<b>2.0. Features Descriptions.....</b>	<b>2-1</b>
2.1. Overview .....	2-1
2.2. User/Operational Interface .....	2-2
2.2.1. Front Panel Displays and Ports .....	2-2
2.2.2. Rear Panel Controls, Jacks and Ports .....	2-7
2.2.3. Remote Control Features .....	2-15
2.3. Channel Access Module (Optional).....	2-16
2.3.1. CAM Module .....	2-16
2.4. Transmission Channel (Trunk) Simulators .....	2-21
2.4.1. Test Channel Configuration Programming.....	2-22
2.4.2. I/O Configurations.....	2-29
2.4.3. I/O Level Control.....	2-30
2.5. Analog Impairment Generators .....	2-35

2.5.1. Amplitude Jitter .....	2-35
2.5.2. Frequency Shift.....	2-36
2.5.3. Gain/Delay Distortion.....	2-37
2.5.4. Gain Hits .....	2-38
2.5.5. Impulse Noise .....	2-40
2.5.6. Bipolar Impulse Noise .....	2-42
2.5.7. Interruptions (Micro-Cutoffs) 1 .....	2-44
2.5.8. Interruptions (Micro-Cutoffs) 2 .....	2-45
2.5.9. Nonlinear Distortion .....	2-46
2.5.10. Phase Hits .....	2-48
2.5.11. Phase Jitter.....	2-49
2.5.12. Single Frequency Interference.....	2-50
2.5.13. White Noise (Random Noise) .....	2-51
2.6. Digital Impairments (PCM/ADPCM Option).....	2-54
2.6.1. PAL Module Features and Application .....	2-55
2.7. Digital Impairments (Extended PCM/ADPCM Option) .....	2-61
2.7.1. EPAL Module Features and Application .....	2-61
2.8. Cellular Audio Processor (CAP) Module Option.....	2-65
2.8.1. Test Topology .....	2-66
2.8.2. TAS Series II CAP System Interface .....	2-67
2.9. Echo/Satellite Delay .....	2-68
2.9.1. Near Talker Echo.....	2-69
2.9.2. Far Talker Echo/Satellite Delay .....	2-74
2.9.3. Intermediate Talker Echo.....	2-78
2.9.4. Listener Echo.....	2-79
2.10. Measurement /Monitoring .....	2-81
2.10.1. Level and Frequency Measurement Module.....	2-81
2.10.2. Measurement Algorithm.....	2-85
2.10.3. Monitoring .....	2-86
2.11. Basic Central Office Emulation .....	2-88
2.11.1. Network Traffic Configurations.....	2-89
2.11.2. Interface Isolation .....	2-93

2.11.3. 4-Wire Configuration Features.....	2-94
2.11.4. 2-Wire Configuration Features.....	2-95
2.11.5. Loop Signaling Features.....	2-98
2.11.6. Call Progress Tones and Switching Features.....	2-105
2.11.7. Dialing Analysis Features .....	2-116
<b>3.0. Programmer's Guide .....</b>	<b>3-1</b>
3.1. Overview .....	3-1
3.2. TAS Series II Command Protocol .....	3-3
3.2.1. Command Types .....	3-3
3.2.2. Command Message Format .....	3-4
3.2.3. Response Formats .....	3-5
3.2.4. Special Commands.....	3-6
3.2.5. Parameter Value Readback.....	3-7
3.3. Transmission Layer Protocols.....	3-9
3.3.1. RS-232C CR/LF Protocol .....	3-9
3.3.2. TAS Series II ACK/NAK Protocol.....	3-10
3.3.3. TAS Series II GPIB Protocol.....	3-13
3.4. Programming Sequence .....	3-18
3.4.1. Transmission Channel Impairments .....	3-18
3.4.2. Test Channel Configuration Control .....	3-19
3.4.3. Basic Central Office Simulator .....	3-20
3.5. TAS Series II Commands for Program Cartridge Version 2.20 and Higher.....	3-24
3.5.1. Conventions to Specify Commands.....	3-24
3.5.2. Impairment Command Group Overview .....	3-25
3.6. Command Descriptions.....	3-26
3.6.1. System Administration .....	3-26
3.6.2. Amplitude Jitter.....	3-30
3.6.3. Audio Processor (CAP) Module Control .....	3-31
3.6.4. Auxiliary (Intermediate Talker or Listener) Echo 1 .....	3-33
3.6.5. Auxiliary (Intermediate Talker or Listener) Echo 2.....	3-34
3.6.6. Echo Control (Near & Far) .....	3-35



3.6.7. Extended PCM/ADPCM Module Control .....	3-36
3.6.8. Frequency Shift.....	3-39
3.6.9. Gain/Delay .....	3-40
3.6.10. Gain Hits .....	3-48
3.6.11. Impulse Noise (IEEE) .....	3-49
3.6.12. Impulse Noise (Bipolar) .....	3-51
3.6.13. Impairments Generator I/O .....	3-53
3.6.14. Line Control .....	3-57
3.6.15. Channel Interruptions (Micro-Cutoff) 1.....	3-60
3.6.16. Channel Interruptions (Micro-Cutoff) 2.....	3-61
3.6.17. Signal Measurements .....	3-62
3.6.18. Nonlinear Distortion (Intermodulation Distortion) .....	3-63
3.6.19. PCM/ADPCM.....	3-64
3.6.20. Phase Hits .....	3-67
3.6.21. Phase Jitter.....	3-68
3.6.22. White Noise .....	3-69
3.6.23. Satellite Delay 1 EIA CCITT and ETSI-1 .....	3-70
3.6.24. Satellite Delay 2 ETSI-2.....	3-71
3.6.25. Single Frequency Interference (SFI).....	3-72
3.6.26. Network Signaling.....	3-74
3.6.27. Switching .....	3-78
3.6.28. Tone Generator .....	3-80
3.7. Superseded Command Descriptions .....	3-81
3.7.1. Auxiliary (Intermediate or Listener) Echo.....	3-81
3.7.2. Satellite Delay/Echo.....	3-82
3.7.3. Impulse Noise .....	3-84
3.7.4. Impairment Generator I/O.....	3-86
3.7.5. Line Control .....	3-87
3.7.6. Channel Interruptions .....	3-88
3.7.7. Switching .....	3-89
<b>4.0. TAS Series II Error Codes.....</b>	<b>4-1</b>
<b>5.0. Technical Specifications.....</b>	<b>5-1</b>

5.1. General .....	5-1
5.2. Signal Measurement .....	5-2
5.3. Impairments Generator I/O .....	5-3
5.4. Transmission Impairments .....	5-5
5.5. PCM/ADPCM Module (Option).....	5-15
5.6. Extended PCM/ADPCM Module (Option) .....	5-16
5.7. Cellular Audio Processor (CAP) Module Option.....	5-17
5.8. Basic Central Office Emulation .....	5-18
5.9. Remote Control Interfaces .....	5-23
5.10. Frequency Response Characteristics .....	5-25

## 1.0. INTRODUCTION

---

### 1.1. Overview

The TAS Series II is an advanced new Telephone Network Emulator from Spirent Communications. The TAS Series II provides new high-end solutions for development, testing, and evaluation of modems, fax machines, voice/data terminals, transmission test sets, and other voice bandwidth data communications devices.

The TAS Series II offers complete bi-directional impairments simulation (Figure 1-1), The TAS Series II provides greatly enhanced echo simulation capabilities and the ability to emulate virtually all worldwide central office signaling formats.

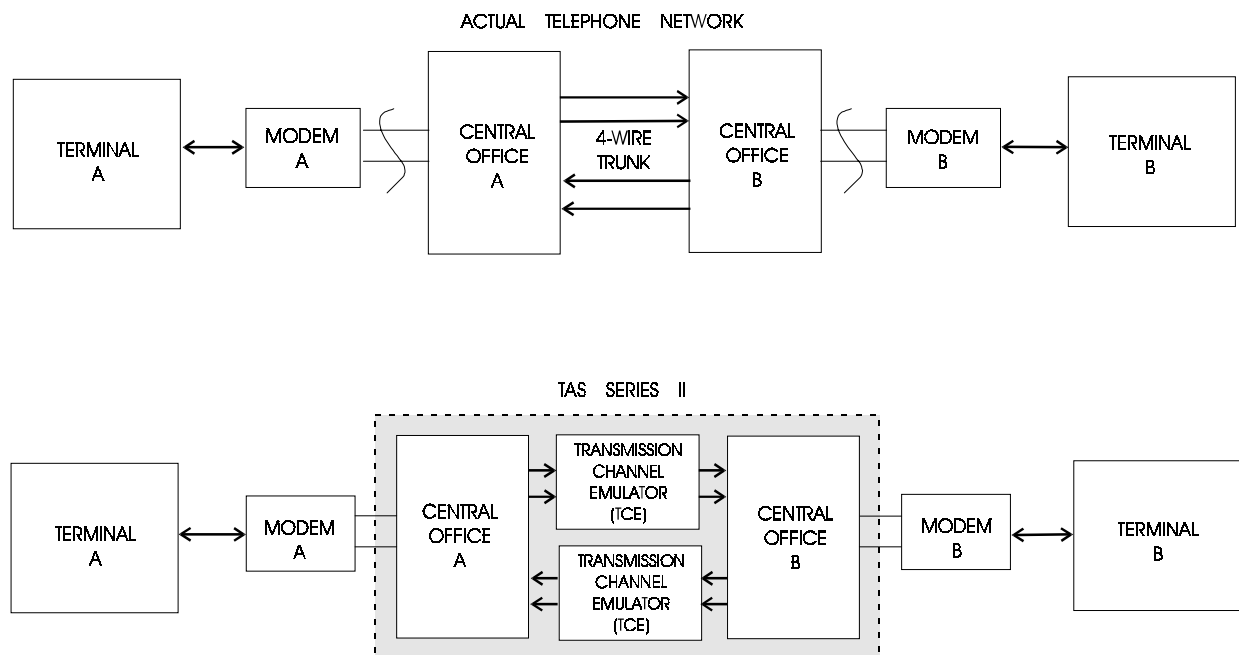

**Figure 1-1. Series II Block Diagram**

Because the TAS Series II is compatible with testing standards from EIA, CCITT, ETSI, Bell Operating Companies, AT&T, Nippon Telephone and Telegraph, and many other companies and industry organizations, test results have immediate credibility. In addition, the TAS Series II is software-compatible with the older TAS 1010 Channel Simulator, thereby protecting your prior investment in test procedures and software.

TAS Series II works with the TAS Gemini Dual Terminal Emulator and TASKIT software to provide completely automatic modem testing. TAS Series II test results track with those obtained on the popular TAS 1010 and TAS 100 Series

simulators, so the test results agree with the largest installed base of Telephone Network Simulators in the world.

## 1.2. TAS Series II Applications

### 1.2.1. Modem Evaluation and Test

Series II is an ideal tool for modem evaluation and test because it emulates an end-to-end telephone network and provides a stable, controllable source of telephone network impairments. Series II makes it easy to evaluate modem call setup capabilities and impairment sensitivity. Combine the Series II with the Gemini dual data analyzer and TASKIT software as shown in Figure 1-2 for a complete modem evaluation workstation. For manufacturing test applications, integrate the Series II and Gemini into a test fixture via IEEE-488 (GPIB) or RS-232 control interfaces.

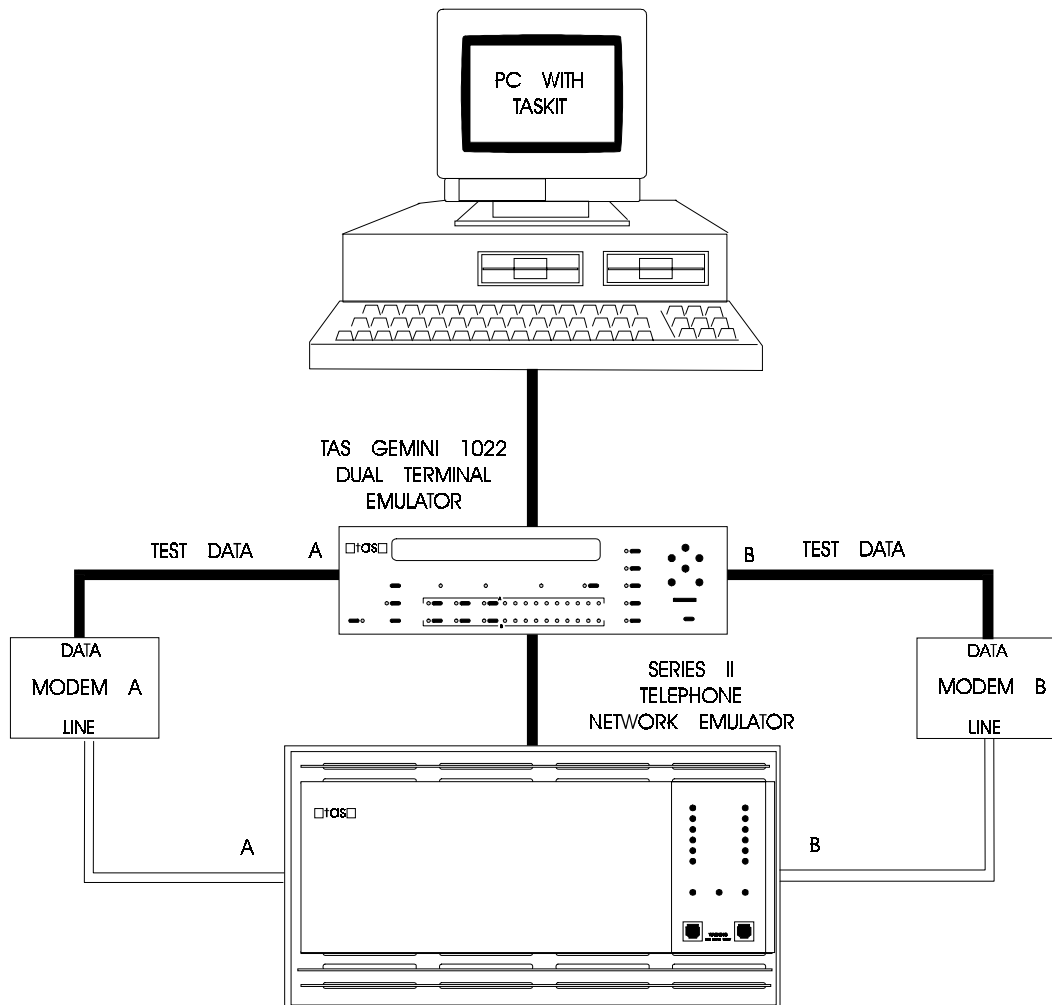
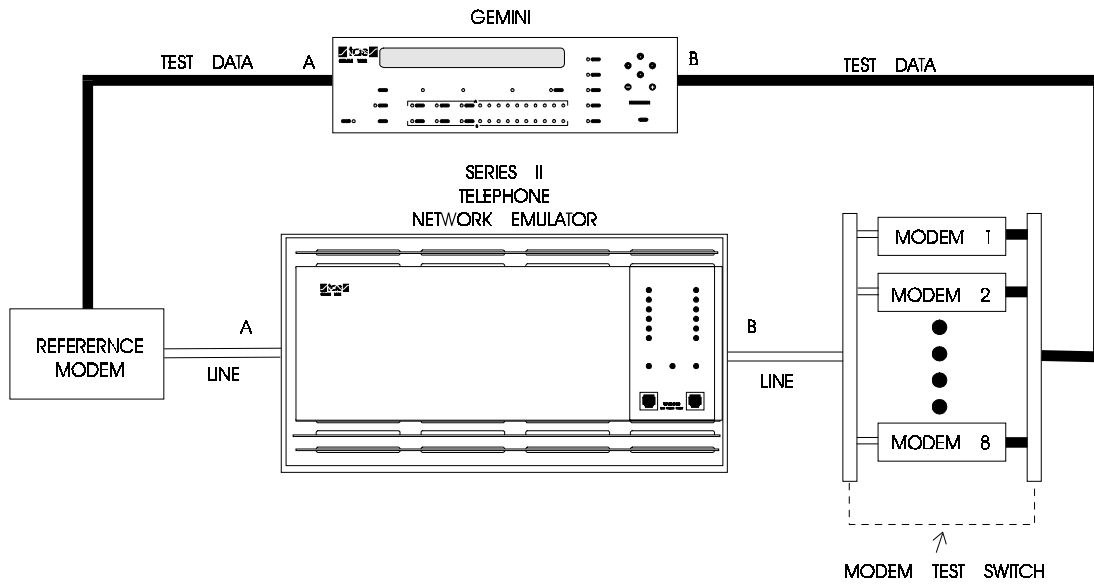

Figure 1-2. Series II Automatic Modem Testing Configuration

Series II can also be used with the TAS Modem Test Switch as shown in Figure 1-3 to test several modems in succession, or to test modem inter-operability.



**Figure 1-3. Series II/ 3508 Modem Test Switch Test Configuration**

### 1.2.2. Fax Evaluation and Test

Series II provides a complete testbed for evaluating fax machine performance. Simply connect a fax machine as shown in Figure 1-4, to each station set interface and transmit a test document. With Series II, you can control transmission impairments and central office parameters to thoroughly evaluate fax performance.

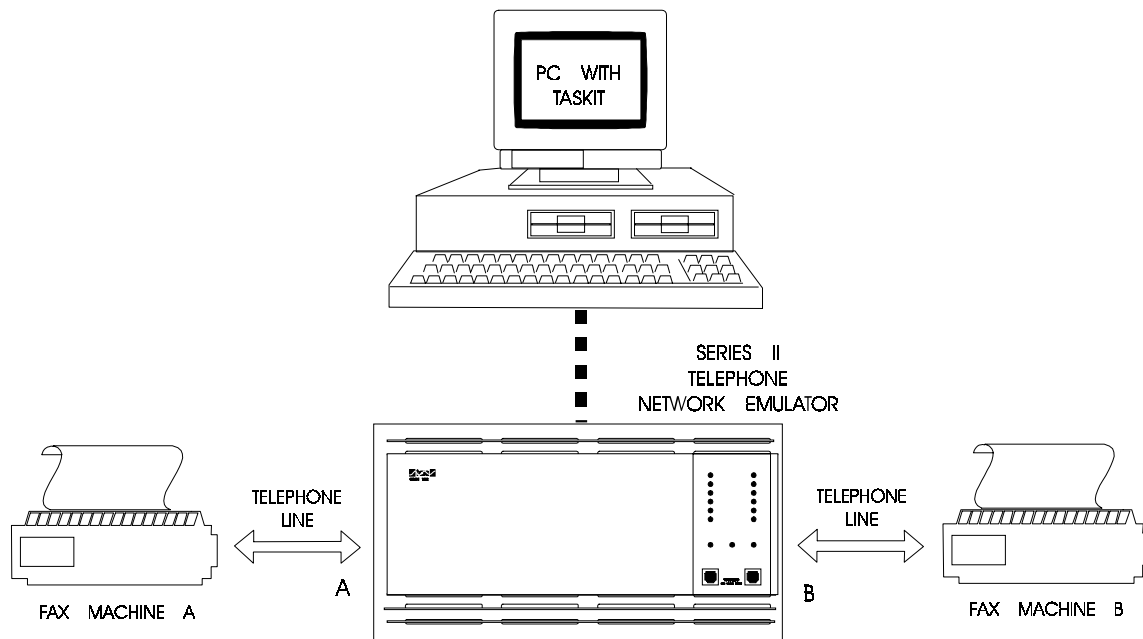

Figure 1-4. Fax Testing Configuration

### 1.2.3. Transmission Test Set Evaluation

Series II provides an accurate, stable source of transmission impairments making it an ideal tool for evaluating the performance of Transmission Impairment Measuring Sets (TIMS) as illustrated in Figure 1-5. Series II provides precise control over all of the parameters that the TIMS measures, such as attenuation, noise, phase jitter, amplitude jitter, etc. You can control the Series II and the TIMS through the GPIB or the RS-232 to achieve completely automatic testing.

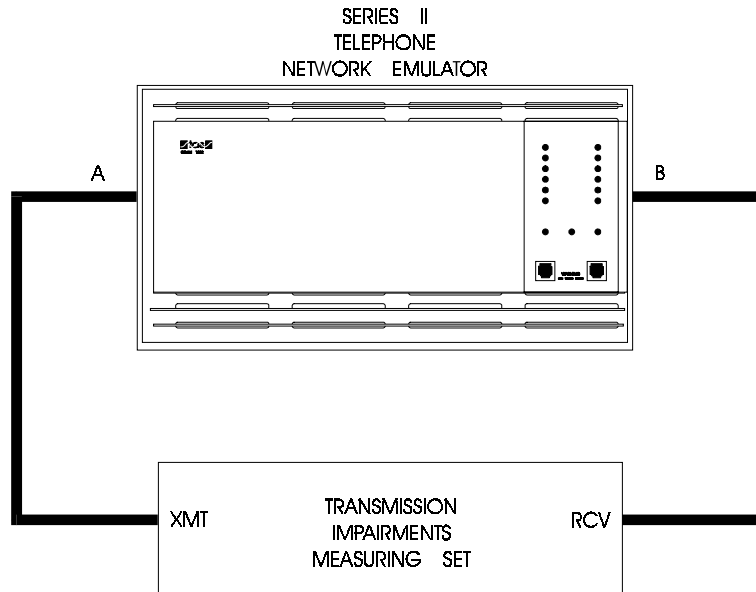

Figure 1-5. Configuration for Evaluating Transmission Impairments Measuring Set



### 1.2.4. Communications Software Evaluation

Series II provides quick and easy evaluation of communications software performance. To evaluate communications software, simply attach a computer and modem to each station set interface as shown in Figure 1-6 and run the communications software on the computer. Adjust Series II impairments and central office parameters to completely evaluate software performance.

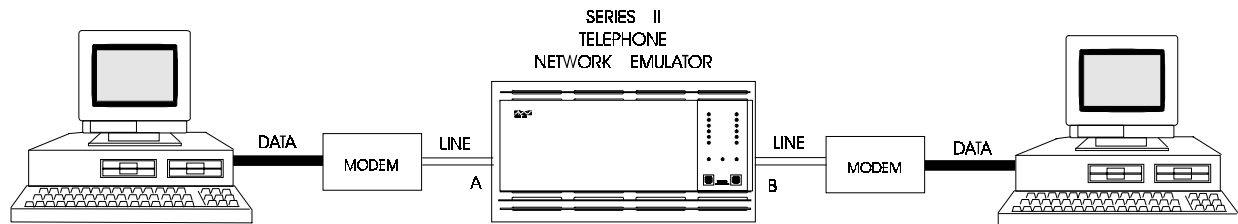

Figure 1-6. Configuration for Communications Software Evaluation

### 1.2.5. Credit Card Verification Terminal Evaluation

Series II allows you to evaluate the performance of data communications devices that contain modems, such as a credit card verification terminal. To evaluate a terminal, simply operate it in the normal manner, but substitute the Series II for the real telephone network as illustrated in Figure 1-7. Adjust the Series II impairments and central office parameters to thoroughly evaluate performance.

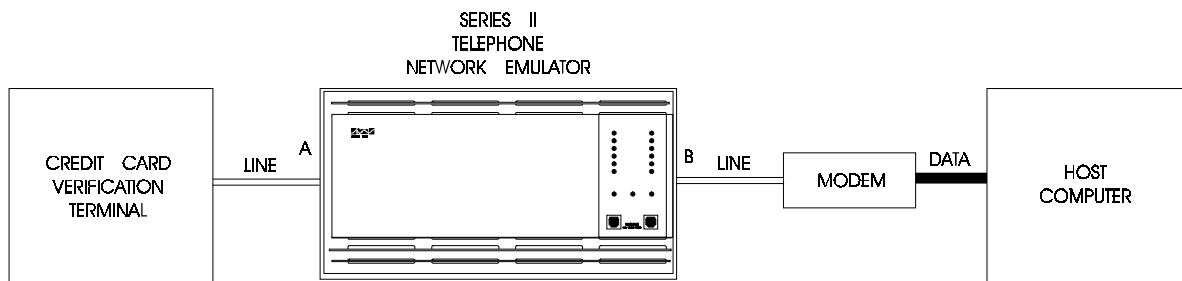

Figure 1-7. Configuration for Credit Card Terminal Evaluation

### 1.3. TAS Series II Major Features

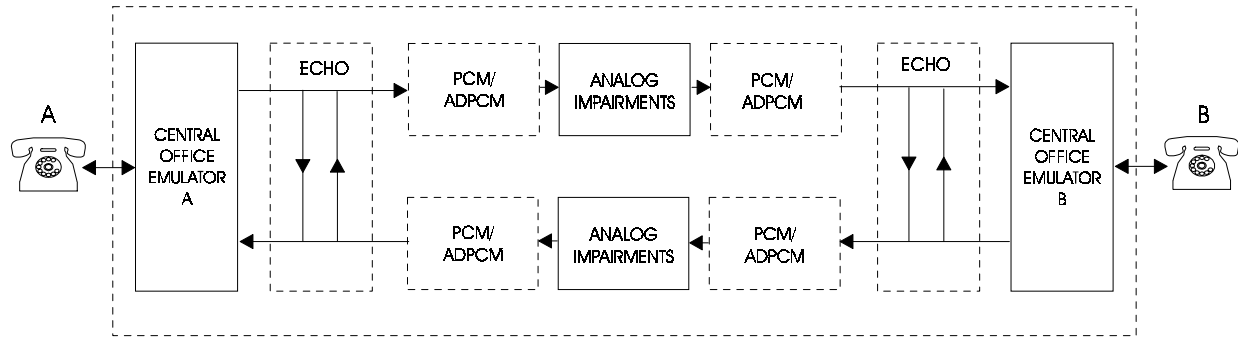

Figure 1-8. Telephone Network Emulator Architecture

#### 1.3.1. Bi-directional Analog Impairments

Series II models provide bi-directional or unidirectional impairments. Bi-directional impairments most closely reflect the operation of real networks and allow thorough evaluation of echo-canceling modems. Series II analog impairments include:

- Attenuation
- White Noise
- Gain Distortion
- Group Delay Distortion
- Non Linear Distortion
- Phase Jitter
- Frequency Offset
- Amplitude Jitter
- Gain Hits
- Channel Interruptions
- Phase Hits
- Impulses
- Single Frequency Interference

Series II provides considerable impairments simulation flexibility including:

- Selectable white noise source bandwidth
- Selectable (expansive or compressive) nonlinear distortion modes
- Selectable white noise pseudo-random sequence
- TTL trigger inputs and sync outputs for impulses

### 1.3.2. Bi-directional Digital Impairments

All Series II models are designed to accept the optional TAS PCM/ADPCM Links (PAL) module. Bi-directional models have one PAL module in each direction of transmission. Each PAL module emulates up to four PCM or ADPCM links and supports the following testing features:

- Mu-law and A-law PCM coding
- 64 kbps PCM and 40 kbps, 32 kbps, 24 kbps, and 16 kbps ADPCM coding
- PCM robbed-bit signaling simulation
- Random bit errors simulation

A bi-directional unit with the optional PAL modules may also accept the optional Extended PCM/ADPCM Links module (EPAL). Typically on intercontinental digital links non-standard ADPCM algorithms are employed. Many transatlantic digital links use the ECI custom ADPCM while many transpacific digital links utilize the OKI custom ADPCM. An EPAL module emulates up to two PCM or non-standard ADPCM Links in both directions and supports the following features:

- 64 kbps PCM and 32 kbps and 24 kbps custom ADPCM coding
- User programmable Frame Slip emulation

### 1.3.3. Selectable Test Channel Configurations

The Series II supports four different Test Channel Configurations. Each test channel configuration is defined by the impairments which are available, the order in which the impairments are presented to the incoming signal, and the background conditions generated by those impairments. The Test Channel Configurations are:

- EIA/CCITT Test Channel is based on EIA/TIA and CCITT specifications and technical bulletins
- ETSI Test Channel 1 is based on the NET 20 specifications and is identical to the EIA test channel except for differences in frequency shift and auxiliary echo
- ETSI Test Channel 2/3 is based on the NET 20 specifications
- Analog Bypass of the Test Channel. All impairments implemented digitally are bypassed to avoid signal digitization. See table 2-3 for a list of the impairments not supported.

### **1.3.4. Advanced Echo Simulation Capability**

Series II provides powerful echo simulation capabilities to facilitate thorough analysis of echo-canceling modems. Series II provides near and far echo, intermediate and listener echoes for each station. Far and intermediate echoes experience all channel impairments and propagation delay. Near echo channels provide direct electronic control of hybrid impedance for realistic, accurate simulation.

### **1.3.5. Comprehensive Central Office Emulation**

All Series II models provide extremely flexible automatic central office emulation. The Series II Central Office Emulator provides the following key features:

- Emulates 2-wire switched, 2-wire non-switched, and 4-wire non-switched operation
- Emulates virtually all U.S. and international call progress signaling formats. All call progress signaling tones may be user-defined
- Dial pulse and DTMF detection
- Constant current or constant voltage battery feed
- Current source programmable up to 126 mA
- Programmable battery feed voltage
- Programmable battery feed resistance
- Programmable ringing parameters: ring level, DC bias, ring frequency, and ring polarity
- Internal or external hybrid balance network

### **1.3.6. Extensive Signal Measurement and Monitoring Capabilities**

Series II accurately measures signal levels at the input and output of each transmission direction. Monitor/measure points are selectable via software control.

### **1.3.7. Built-In Network Status Monitor**

The Network Status Monitor presents the network configuration and call setup status on the Series II front panel. Status information includes the type of network being simulated (2-wire switched, 2-wire private line, 4-wire private line) and switched network status (off-hook, dial tone, ringing, etc.). The Network Status Monitor lets you quickly verify the call setup functions of modems, fax machines, and other data communications equipment.

### **1.3.8. Advanced System Architecture**

Series II uses advanced digital signal processing (DSP) technology to pack the signal processing power of the industry standard TAS 1010 Channel Simulator onto a single circuit board. This results in unprecedented testing features, accuracy, repeatability, and reliability.

The Series II also uses advanced new A/D and D/A conversion technology to achieve much lower levels of background noise. This means that background noise will not contaminate test results, even at receive signal levels as low as -50 dBm.

## 1.4. Guided Tour

### 1.4.1. Front Panel Overview

Figure 1-9 shows the TAS Series II front panel. The panel contains a STATUS and MODE display, and a pair of access connectors. Their functions are as follows:

- The STATUS display indicates the signaling status of the STATION A and STATION B interfaces.
- The MODE display indicates the telephone network interface line configuration.
- The STATION A and STATION B connectors (RJ-45) provide transmission access to the TAS Series II telephone network emulator.

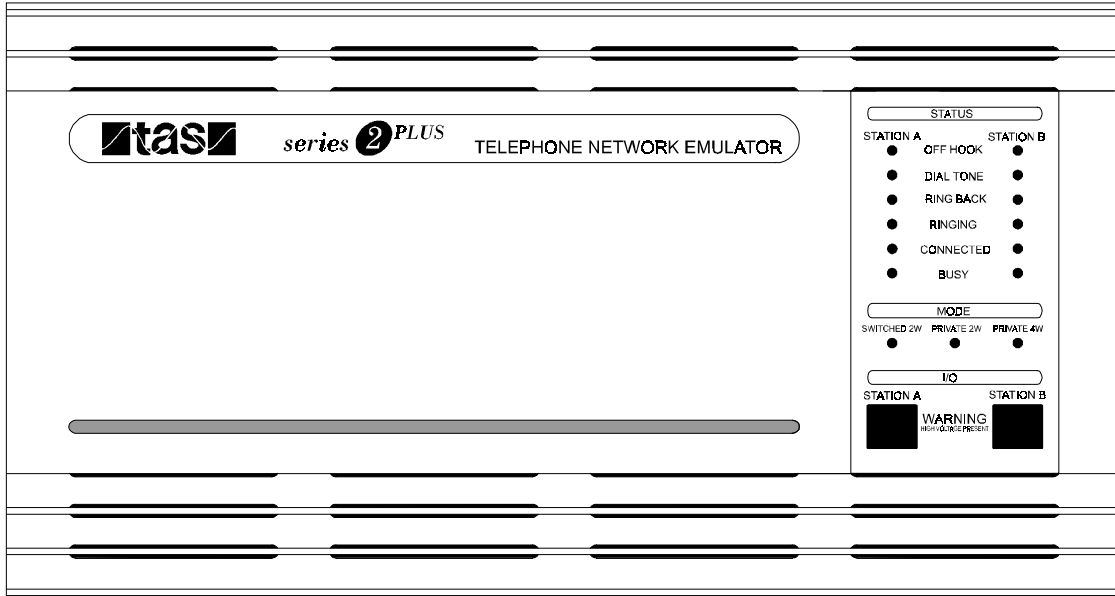

Figure 1-9. TAS Series II Front Panel

### 1.4.2. Rear Panel Overview

Figure 1-10 on the following page shows the TAS Series II rear panel. The following information provides a brief description of each rear panel feature.

- The SCOPE A→B and SCOPE B→A BNC type connectors provide selectable internal signal points for external monitoring.
- The STATION A and STATION B connectors (RJ-45) provide transmission access to the TAS Series II telephone network emulator in parallel with the front panel RJ-45 connectors.
- The External B→A terminal strip provides external access to the B→A portion of the 4-wire path during 2-wire simulation.
- The Balance Networks terminal strip allows a user-supplied balance impedance for the 2- to 4-wire hybrids.
- The rear panel has four BNC connectors: TRIGGER INPUT 1, SYNC OUTPUT 1, TRIGGER INPUT 2, and SYNC OUTPUT 2. The TRIGGER INPUTS provide for external impulse trigger generation. The SYNC OUTPUTS can be used to synchronize other instruments to impulse events.
- The CONTROL (DTE) RS-232 port allows an external computer to control the TAS Series II.
- The AUX (DCE) RS-232 port is reserved for future use.
- The CONTROL (IEEE-488) port allows an external GPIB controller to control the TAS Series II.
- The set of dip switches allows the selection of the remote control communications protocol.
- The MEMORY CARTRIDGE port accepts a TAS Series II program memory cartridge.
- The AC SWITCH/RECEPTACLE ASSEMBLY contains the AC ON/OFF switch, the AC power connector, AC line voltage selection, and the fuse.



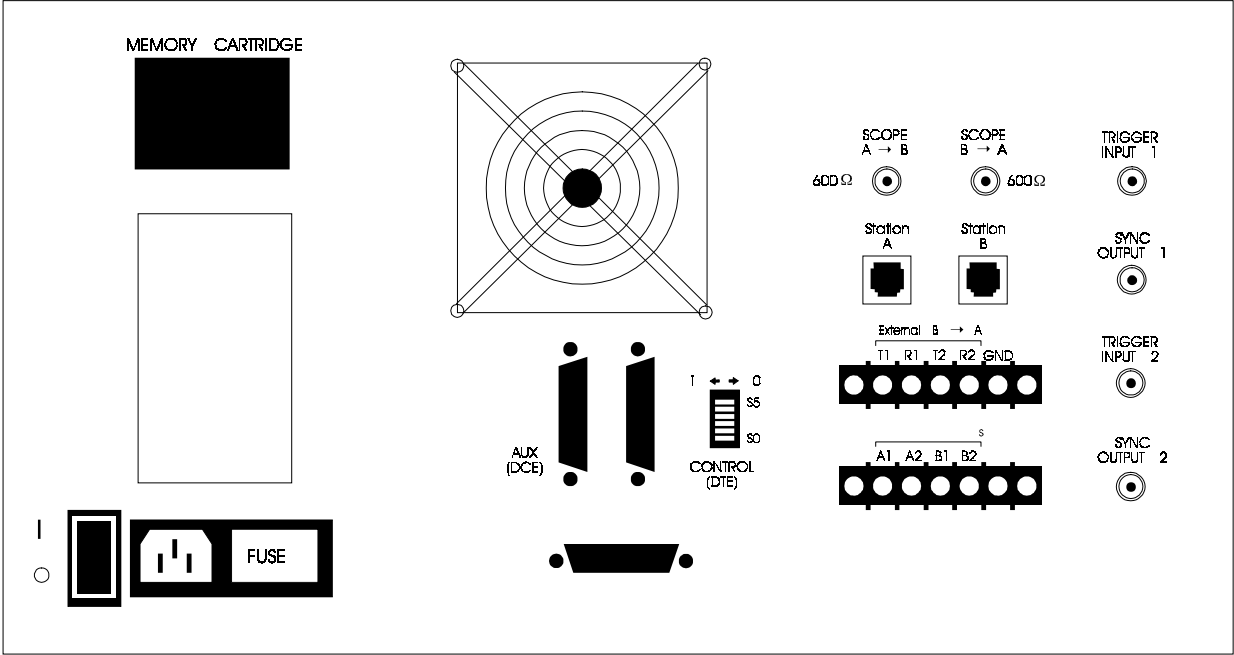

Figure 1-10. TAS Series II Rear Panel

## 1.5. Getting Started

### 1.5.1. Installation

To prepare the TAS Series II for operation, perform the following steps:

1. Unpack the TAS Series II shipping box. Check the contents of the box against the list below.

Please make sure that all parts of your Series II Telephone Network Emulator are present. Save the box and packing materials until you have completed the system installation and initial check. If you must return any equipment to TAS, please use the TAS packing material.

2. Check each item for physical damage. If any item appears damaged, please contact your TAS customer service representative.
3. Check the AC voltage configuration. The current AC voltage setting is visible through a plastic door at the right side of the AC receptacle. This setting should have been factory-set per your locally available power system. Two settings are available: 100 VAC or 240 VAC. The 100 VAC setting supports 100 to 125 VAC, and the 240 VAC setting supports 205 to 250 VAC.

Refer to the AC power information in the Detailed Rear Panel Control Jacks and Ports portion in the *Features Descriptions* section of this manual, or contact TAS for further instructions.

4. Verify that the Program Memory Cartridge is properly installed in the rear of the TAS Series II.
5. Insert the AC power cord into the AC power connector to connect the TAS Series II to an AC power receptacle.
6. Turn on the TAS Series II using the AC switch on the rear panel.

An automatic self-calibration and diagnostics procedure will be performed immediately. During this procedure, the TAS Series II performs the following functions:

1. Upon startup, the STATUS LEDS may flash up to six times, depending upon the equipment arrangement, until all the STATUS LEDs are activated.
2. The STATUS LEDs then turn off sequentially from bottom to top, and then turn on again, sequentially from bottom to top.

3. At six points within the power-up operation, a tone is heard.
4. Calibrates internal signal processing elements.
5. Performs tests on internal circuitry.
6. Saves self-diagnostics results.
7. Successful completion of the power-up procedure is indicated when all the STATUS LEDs turn off (after turning on per step 2 above) and only the 4 Wire Private LED is on.

**NOTE:** If the power-up procedure encounters a failure during its self-test/calibration operation, the sequential movement of LEDs will stop. If necessary, obtain troubleshooting assistance from the TAS Customer Service Department by calling 908-544-8700 or 908-544-8347 (fax).

## 1.6. Quick Start-up Procedure

This section is an overview of each of the three Series 2  $\Leftrightarrow$  Controller communication configurations. An example of each of these configurations is as follows:

- RS232 ACK/NAK Control
- RS232 CR/LF Control
- Control with IEEE-488 Interface

### 1.6.1. Software Control with the RS-232 ACK/NAK or CR/LF Interface

Connect the hardware as shown in Figure 1-11.

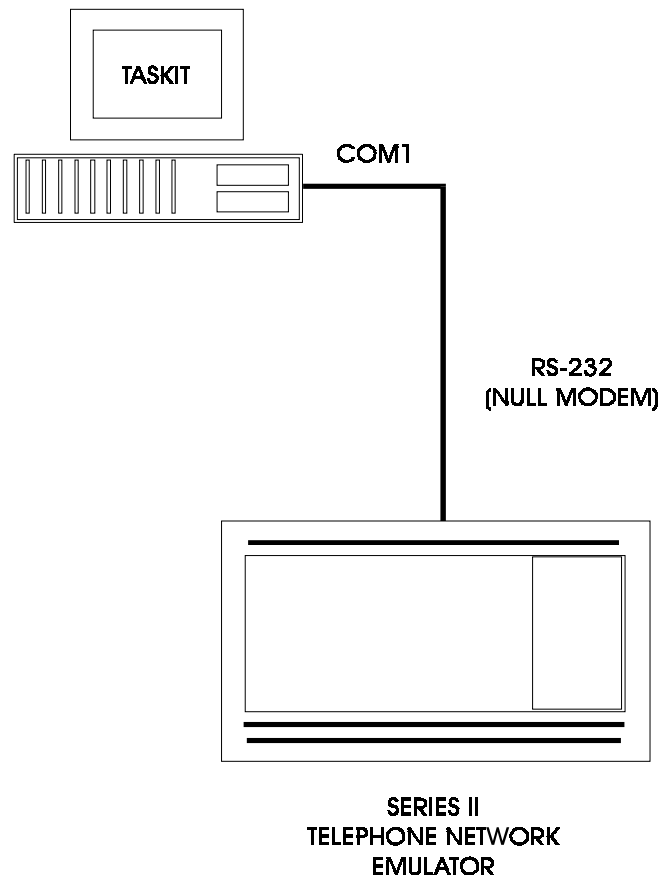

**Figure 1-11. Control with the RS-232 Interface**

Note: Control (DTE) port is located on the rear panel of the Series II

Set the system configuration remote protocol to "RS-232 ack/nak" or "RS-232 CR/LF" by setting the dip switch on the rear of the unit. From top to bottom, set the dip switch as shown in Section 2.2.2.

Reset the Series II by switching "off" then "on" the rear panel AC power switch.

Configure the RS-232 interface on the controller as follows:

data bits: 7

parity: odd

stop bits: 1

bit rate: equal to rate set by Series II DIP switch

### **1.6.2. Control with IEEE-488 Interface**

Interconnect the hardware as shown in Figure 1-12.

Set the dip switch on the rear of unit as shown in Section 2.2.2. Reset the Series II by switching "off" then "on" the rear panel AC power switch. Refer to section 3, Programmer's Guide for additional information.

The TAS Series II GPIB protocol supports a bus communication architecture in which the TAS Series II is one of the devices being controlled. The system controller initiates all transactions.

### **1.6.3. In Case of Trouble**

If you encounter a problem setting up or operating your TAS Series II system, review the following paragraphs. If you are still unable to resolve the problem, consult the technical staff at TAS. Before calling TAS, gather all information relative to your problem, including the serial numbers on your equipment, software version, and Program Memory Cartridge version. Please try to make your problem description as concise and detailed as possible.

Here are some helpful hints.

- If the Series II unit won't turn on, check the AC power connection and the fuse.
- If all front panel lights come on and stay on when the TAS Series II is powered up and there is no other response, see if the Program Memory Cartridge is securely installed in the rear of the channel emulator enclosure. (Turn power off to perform this check.) Turn the unit off and then turn it on again (cycle power).

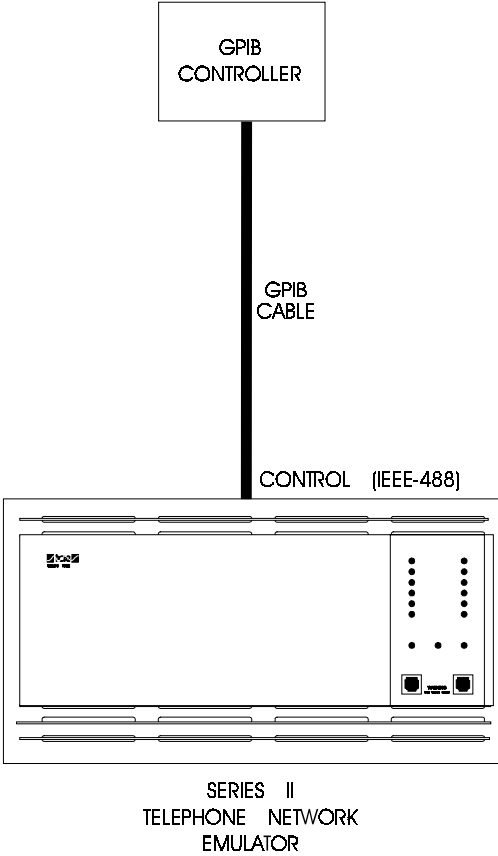

**Figure 1-12. GPIB Software Control**  
Note: Control (IEEE-488) is located on the rear panel.

## **1.7. Feature Release History**

### **1.7.1. Version 2.31 Features**

The following features have been added to the Series II version 2.31 cartridge.

- Support for the Analog Bypass test channel topology

### **1.7.2. Version 2.20 Features**

The following features have been added to the Series II version 2.20 cartridge.

- Support for Cellular Audio Processing (CAP) module for the wireless End-to-End solution

### **1.7.3. Version 2.10 Features**

The following features have been added to the Series II version 2.10 cartridge.

- Extended Caller ID including Caller Name Delivery (UCO)
- RITT Gain/Delay filters
- “True Voice” Gain/Delay filters
- Extended Phase Jitter and Phase Hit Ranges
- Support for Extended PCM/ADPCM Links module

### **1.7.4. Version 2.02 Features**

The following features have been added to the Series II version 2.02 cartridge.

- Support for additional bit rates for CFLF RS-232 remote control protocol

### **1.7.5. Version 2.00 Features**

The following features have been added to the Series II version 2.00 cartridge.

- CCITT Cable Gain Filters
- White Noise Weighting Selection for Psophometric Standard
- Series II Options Query Command (/AD,Qq/)
- Extended Ringing Frequency Range (14 Hz to 120 Hz)
- Call Progress Tones Frequency Range Extended Down to 100 Hz



### 1.7.6. Version 1.30 Features

The following features have been added to the Series II version 1.30 cartridge.

- Selectable Test Channel Configuration including:  
EIA, CCITT and ETSI (NET 20) Configurations
- Single Frequency Interference Sweep Mode
- White Noise Weighting Selection for ETSI NET 20 Standard
- Auxiliary Echo (Intermediate Talker or Listener Echo)
- New TAS 1010-compatible IMD Algorithm
- Enhanced EIA Gain/Delay Filters
- New Gain/Delay Filters per ETSI NET 20 Standard
- Parameter Readback (input values returned to user)
- Attenuator Readback (current setting returned to user)
- Loop Current Selectable in 2 mA Steps up to 126 mA
- Selectable Loop Current Polarity
- 1 Volt Ringing Voltage Resolution
- Selectable Ringing Polarity
- Selectable DC Ringing Bias
- Loopback Relay control
- Program Resistor Relay control
- Dialed Telephone Number Readback

### 1.7.7. Version 1.21 Features

The following features were included in the Series II version 1.21 cartridge.

- A TAS 1010 Compatible Nonlinear Distortion Algorithm replaced the proprietary Nonlinear Distortion Algorithm.
- Bipolar Impulse noise duration and step size have been modified. The step size of the duration parameter changed from 0.1 msec to 0.125 msec.

### **1.7.8. Version 1.20 Features**

The following features were included in the Series II version 1.20 cartridge.

- The command set was expanded to include the internal/external hybrid balance network command (i.e. the LC,B command was added).
- The measurement command (MM,R) was modified to make the Series II compatible with the TAS 1010 when the Series II is configured for reversed impairment simulation.
- Parameter ranges were extended for several commands:  
Switching Delay (SW,M) range to 60,000 msec  
Dial Tone Delay (SW,N) range to 60,000 msec  
Signaling Cadence (SG,R) range to 60,000 msec  
Busy Cadence (SG,B) to range to 60,000 msec  
Bipolar Impulse Noise Interval to range 60,000 msec
- A 40 Kbit ADPCM Quantization Rate was added to the PCM/ADPCM option (see /PC,Q/ command).

### **1.7.9. Version 1.10 Features**

The following features were included in the Series II version 1.10 cartridge.

- Audio and visual indications were added to display the progress of the Series II power-up sequence.
- The AGC operation now includes muting the speaker during the AGC operation and automatic reconfiguration of the signal path to the pre-AGC setting upon completion of the operation.

## 1.8. Series II Options

### 1.8.1. Universal Central Office (UCO) Emulation

Universal Central Office (UCO) Emulation is an exciting new feature that significantly expands the Central Office (Exchange) emulation capabilities of the TAS Series II. This important feature allows the Series II to emulate practically any exchange signaling format that exists on public switched telephone networks worldwide as well those found in Private Branch Exchanges (PBXs) environments. UCO provides the user with the capability to test the call setup functionality of his equipment for a universe of domestic and international conditions.

### 1.8.2. Summary of Major UCO Features

Series II UCO provides the industry's most extensive and flexible central office (exchange) emulation features. The major features include:

Emulates 2 independently controlled central offices (exchanges), each with more than 100 user definable parameters.

Emulation of virtually all U.S. and international call progress signaling tones including:

- Dial Tone
- Second Dial Tone
- Recall Dial Tone
- International Dial Tone
- Ringing Tone (Ringback)
- Busy Tone
- Receiver Off Hook Tone
- Congestion (Reorder, Fast Busy, Network Busy)
- Special Information Tone
- Warning Tone
- Number Unobtainable Tone
- Call Waiting Tone
- Recording Tone
- Executive Override Tone
- Intercept Tone

- Pay Tone
- Function Acknowledgment Tone
- Confirmation Tone
- Route Tone (Call in Progress)
- Prompt Tone (Credit Card Bong Tone)

Provides more than 240 predefined call progress signaling tones.

Provides predefined call setup sequences for more than 30 different countries.

Provides a powerful arbitrary waveform synthesizer with an easy to use script language that allows the user to build virtually any custom signaling tone.

Emulates Caller ID (Call Number Delivery), Call Waiting and automatic credit card call setup sequences. (additionally Caller Name Delivery in v2.10 and higher)

Supports user defined call setup sequences. Allows up to a 100 digit dialing sequence.

Emulates reverse polarity signaling.

Provides extensive dialing analysis for both DTMF and dial pulsing.

### **1.8.3. PCM/ADPCM Module**

The PCM/ADPCM Links (PAL) module provides the means to test modem performance over various simulated digital transmission systems. The PAL module can be positioned in the signal path to appear either before satellite delay or after the noise summer. With a PAL module, it is possible to perform the following functions:

- Simulate up to 4 tandem, digitally coded transmission links
- Specify each link as mu-law or A-law with 64 kbps PCM, 40 kbps ADPCM, 32 kbps ADPCM, 24 kbps ADPCM, or 16 kbps ADPCM
- Inject random bit errors on the PCM or ADPCM bit stream of one of the 4 transmission links
- Insert PCM robbed-bit signaling on one of the 4 transmission links

### 1.8.4. Extended PCM/ADPCM Module

The Extended PCM/ADPCM Links (EPAL) module provides the means to test modem performance over various simulated digital transmission systems currently found over international links. The EPAL module (also called the Digital Channel) can be positioned in the signal path to appear either before satellite delay or after the noise summer. With an EPAL module, it is possible to perform the following functions:

- Simulate up to 2 tandem, digitally coded transmission links
- Specify each link as mu-law or A-law with 64 kbps PCM, 32 kbps ECI or OKI ADPCM, or 24 kbps OKI ADPCM
- Inject random frame slip errors on the PCM or ADPCM bit streams of one of the 2 transmission links in each direction

### 1.8.5. Cellular Audio Processor (CAP) Module

The TAS Series II Cellular Audio Processor (CAP) Module emulates the companding, pre-emphasis/de-emphasis, and limiting characteristics associated with end-to-end cellular network connections. These VF (Voice Frequency) characteristics are defined by EIA/IS-19-B, and 20A as well as EIA/TIA-553, and EIA/TIA/IS-55 cellular standards. TAS Series II CAP allows the TAS Series II Telephone Network Emulator to provide the user with a cost effective and convenient means to test the performance of cellular modems and other VF (Voice Frequency) devices that must operate over analog cellular networks.

Multiple test topologies are supported by the Series II CAP to allow the TAS Series II to address a variety of test applications including:

#### **Complete End-to-End (VF to RF to VF) Cellular Test Application**

In this application the TAS Series II with a CAP module in addition to a base station emulator (TAS 6600) and RF channel emulator (TAS 4500) are used to test the effects of both the VF and RF characteristics of a cellular communications channel. This application requires the Series II CAP to be configured in the “GT Cellular” topology.

#### **Stand Alone VF Only Test Application**

In this application the TAS Series II with the CAP module are used to test the effects of only the VF characteristics of a cellular communications channel. This application requires the Series II CAP to be configured in the “Tandem” topology.

## **System Requirements**

The TAS Series II Telephone Network Emulator requires the following resources to provide the cellular audio processor feature:

- TASKIT/Series II for Windows Software Version 1.30 or higher
- TAS Series II Program Memory Cartridge Version 2.20 or higher
- TAS Series II Cellular Audio Processor Hardware Module Version 1.0 or higher

### **1.8.6. Channel Access Module**

The Series II optional Channel Access Module (CAM) provides the means to obtain 4-wire access to the transmit and receive ports of the A→B and B→A transmission channels when the Series II is configured for 2-wire operation. With the CAM, it is possible to perform the following functions:

- Cascade external transmission or simulation equipment with the internal transmission channels of the Series II.
- Access all four ports of the Series II 2-wire to 4-wire hybrids including the transmit and receive 4-wire ports.
- Simulate a 4-wire switched network configuration.

### **1.8.7. Line Interface Adaptor**

The TAS Line Interface Adaptor (LIA) is a general purpose breakout box for telecommunications applications. The LIA provides several alternative connection types to the standard RJ-45 modular jack. These alternatives include banana jacks, 2-wire RJ-11 jack, 4-wire RJ-11 jack, and WECO 310 type connector. In addition to the different connector types, the LIA also provides a switchable 6.1 dB attenuator pad on pins 4 and 5 of the network RJ-45 connector.

## 1.9. Companion Products

### 1.9.1. TAS Gemini Dual Terminal Emulator

The TAS Gemini Dual Terminal Emulator is a data communications tester/analyzer that is specifically designed for end-to-end testing of modern data communications equipment by including two data analyzers in one compact package. Gemini provides a host of digital tests such as bit error rate, throughput, polling, calls test, and message analysis. Gemini displays test setup and test results information on its 80 character main display. Gemini maintains this information for each of its two independent data analyzers. In addition to performing error rate and throughput tests, Gemini allows you to enter and send command strings to auto-dial modems. This completely eliminates the need for a separate terminal or protocol analyzer.

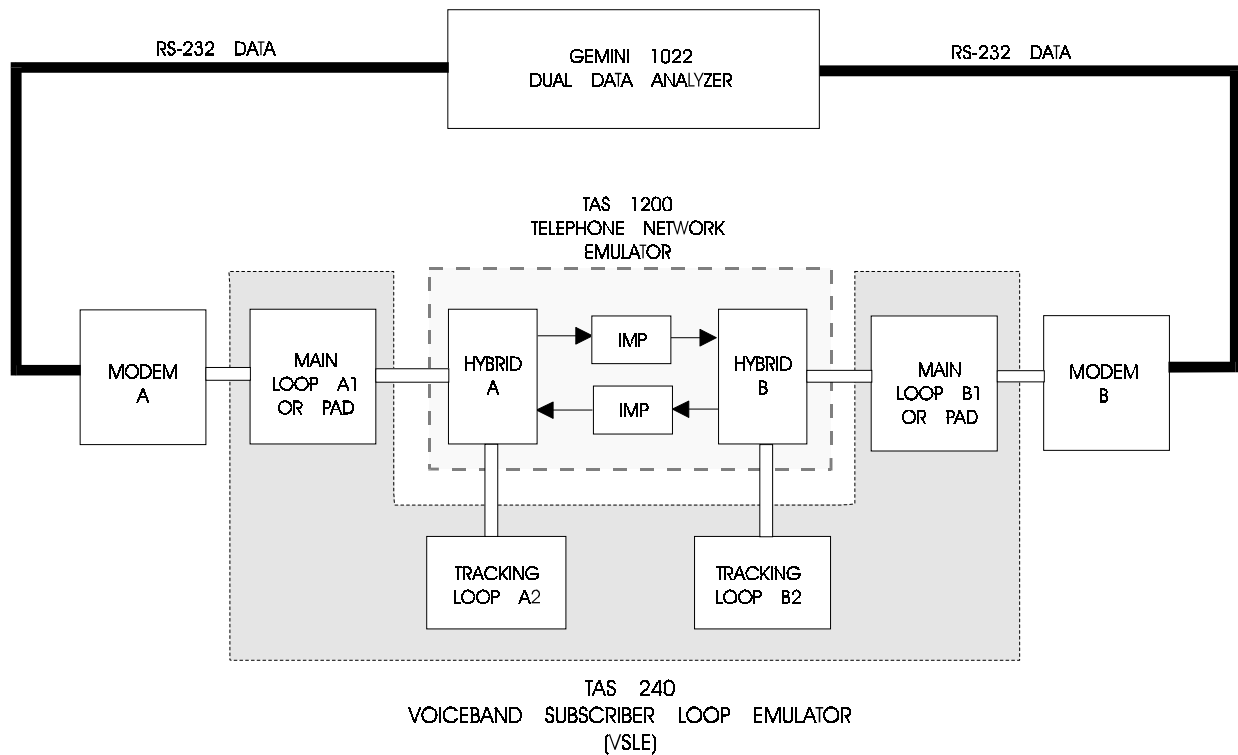

**Figure 1-13. VSLE Application**

### **1.9.2. TAS 3508A Modem Test Switch**

The TAS 3508A Modem Test Switch (MTS) is a switching unit that allows one of nine modems to be switched to a common port under IEEE-488, RS-232, or front panel control. The MTS is designed to simplify and streamline automatic testing of modems, DDS sets, ISDN terminal adaptors, and other data communications equipment.

A simple cascade arrangement makes it possible for one "master" switch to control up to 31 additional switches, allowing one of 256 modems to be switched to a common port. The MTS can be easily integrated into existing automatic test arrangements with other TAS components and TASKIT software to provide fully integrated test systems.

### **1.9.3. TAS 240 Voiceband Subscriber Loop Emulator**

The TAS 240 Voiceband Subscriber Loop Emulator (VSLE) provides convenient, accurate simulation of voiceband subscriber loop characteristics. The VSLE is designed for complete compatibility with emerging and proposed specifications from the Electronic Industries Association (EIA), the European Telecommunications Standards Institute (ETSI), and the CCITT.

The VSLE can be used in conjunction with all TAS Telephone Network Emulators and TASKIT software to facilitate complete evaluation of advanced high-speed modems as illustrated in Figure 1-13. It emulates four complete subscriber loops. These four loops are organized as a "main" loop and a "tracking" loop at each side of the network. The main loop emulates the telephone subscriber loop and the tracking loop balances the hybrid in the telephone network emulator.



## **2.0. FEATURES DESCRIPTION**

---

### **2.1. Overview**

The TAS Series II Telephone Network Emulator is comprised of four major functional components, these are:

#### **The User Interface**

This includes all connectors, indicators, input/output jacks, and user controls on both the front and rear panels of the Series II, as well the remote control protocols.

#### **Transmission Channel Emulation**

This component includes the circuitry which generates all of the impairments of the Series II. These impairments are divided into digital impairments, analog impairments, and echo. The transmission channel also contains both the input and output level control sections. A major feature of the transmission channel is programmable test channel configurations, this allows the impairment profile (the impairments which are present and their order) to be selected. The Series II model 1200 supports channel configurations for the Electronic Industries Association (EIA), European Telecommunications Standards Institute (ETSI), and the International Telegraph and Telephone Consultative Committee (CCITT).

#### **Measure/Monitoring**

This includes the level and frequency measurement, audio output, and scope jack outputs.

#### **Central Office Emulation**

This component includes all of the simulation required to emulate both switched and private line telephone networks. The Series II supports full programmability of exchange configuration features, loop signaling, call progress tones, and dialing analysis. Both pulse dialing and DTMF (Dial Tone Multi-Frequency) are fully supported.

Each of these sections is fully explained in this section of the manual.

## 2.2. User/Operational Interface

The user interface is presented on the front and rear panels, and by the remote control protocols. The front panel contains status LEDs and RJ-45 modular jacks for access to the network. The rear panel contains the power entry module, memory cartridge, fan, control interface (connectors and a switch), modular jacks (paralleled with those on the front panel), and several additional connectors.

### 2.2.1. Front Panel Displays and Ports

On the right hand side of the front of the Series II is a sub-panel which contains LEDs and the station A and B modular jack receptacles (see Figure 2-1). The LEDs are used to indicate the network mode and station interface status, in addition these LEDs are used to indicate any diagnostic failure encountered during a system power-up, or a "soft-reset".

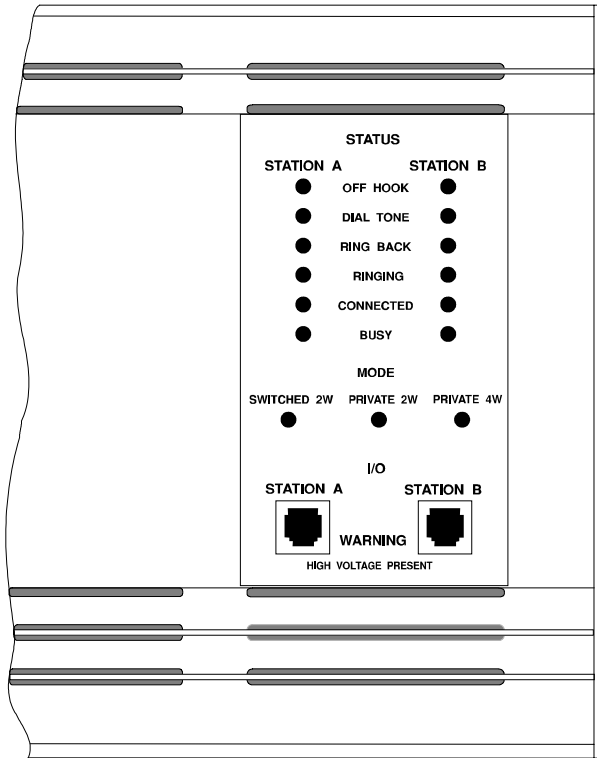

Figure 2-1. Front Panel Displays and Ports

## Network Mode LEDs

The network may be programmed to operate in one of three modes. The "MODE" LED which corresponds to the current state will be lit. The network mode LEDs and their meanings are:

SWITCHED 2W - Indicates that the telephone network emulation is configured for 2-wire switched or 2-wire auto-switched mode.

PRIVATE 2W - Indicates that the telephone network interface emulation is configured for 2-wire private line mode.

PRIVATE 4W - Indicates that the telephone network interface emulation is configured for 4-wire private line mode.

## Station Interface Status LEDs

The status LEDs are used to indicate the status of the station interface when the mode is 2-wire switched or 2-wire auto-switched. The status indicates the state of the signaling at both stations A and B. The status of the station interface is defined by the following:

OFF HOOK: indicates that station A and/or B is off hook and that loop current is flowing.

DIAL TONE: indicates that station A and/or B is receiving dial tone.

RING BACK: indicates that station A or B is receiving a ring back tone.

RINGING: indicates that station A or B is receiving ringing voltage.

CONNECTED: indicates that the call set-up sequence has been successfully completed and that stations A and B are connected.

BUSY: indicates that an unsuccessful attempt was made at station A and/or B to ring the opposite station. This can happen when the dialed station is off hook, or because the number dialed at one station is different from the other station's telephone number.

<p><b>NOTE:</b> At any given time one station may have more than one LED lit. For example once one telephone (or modem) goes off hook both the "OFF HOOK" and "DIAL TONE" LEDs will both be lit for that station.</p>
---

### **Diagnostic Failure Indication**

When powering up, or after sending a "soft" reset command, the front panel indicators go through a start-up sequence as described in the INTRODUCTION section of this manual. If a failure occurs during this start up, the state of the indicators are frozen at that point. If no problems are encountered, the indicators are extinguished except for the Private 4W indicator (default configuration).

### **Station A and B Modular Jacks**

Station A and station B modular telephone jacks are RJ-45 type receptacles, they are located in the lower right-hand corner of the front panel. These station set interfaces conform to all mechanical/functional characteristics specified in the EIA TR30.3 Telecommunications Systems Bulletin No. 18. The pin configurations for 2-wire and 4-wire station set interfaces are shown in Figure 2-2 and Figure 2-3.

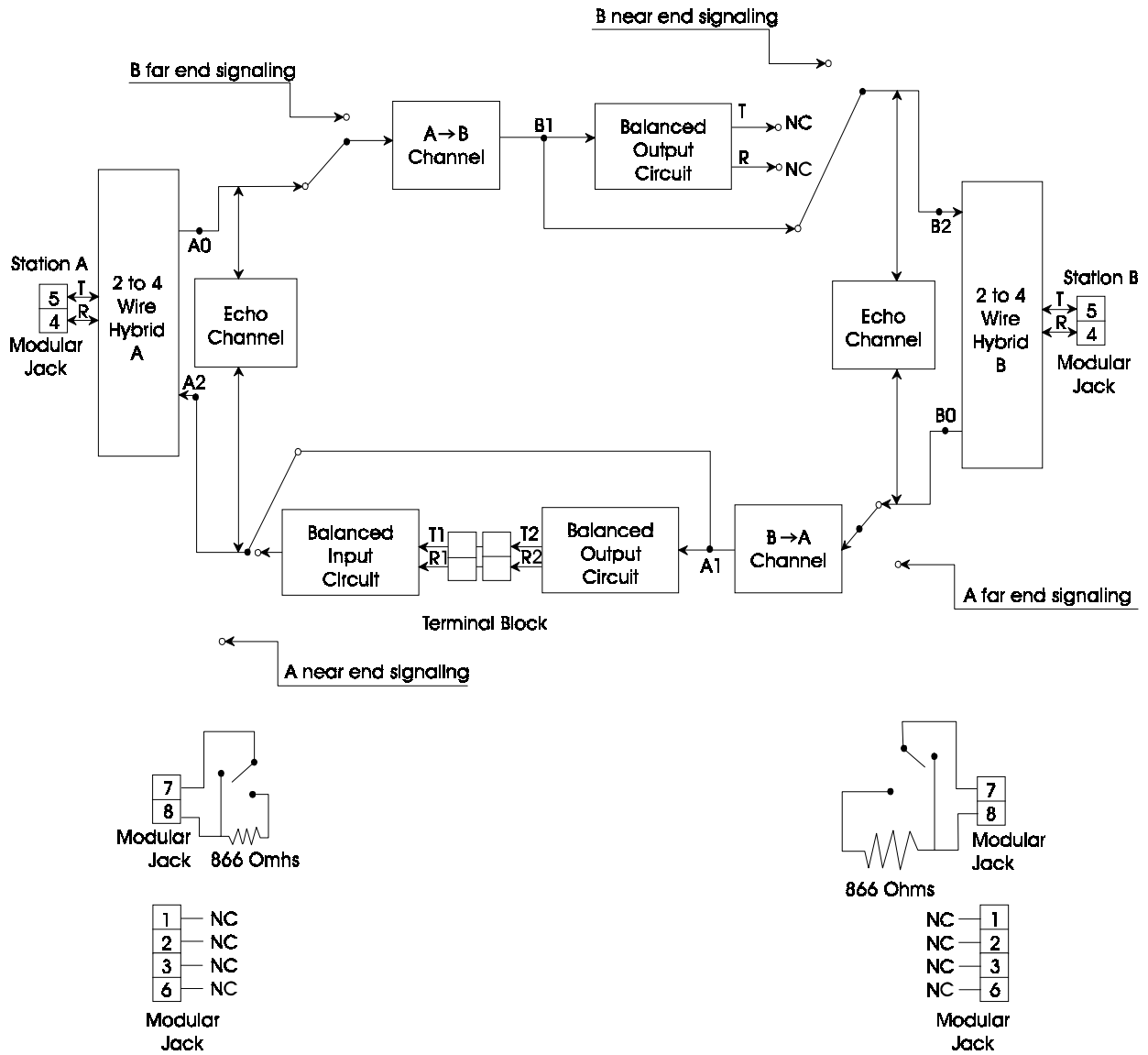

Figure 2-2. Station Interface in 2-Wire Configuration

2-6 TAS Series II Operations Manual

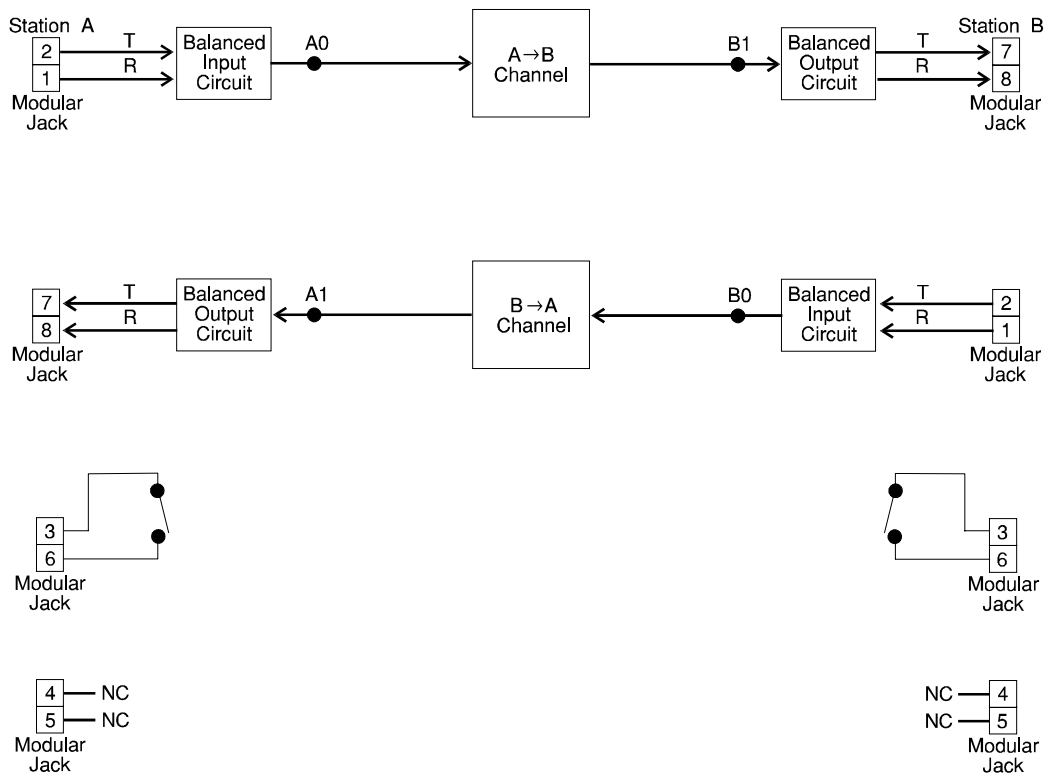
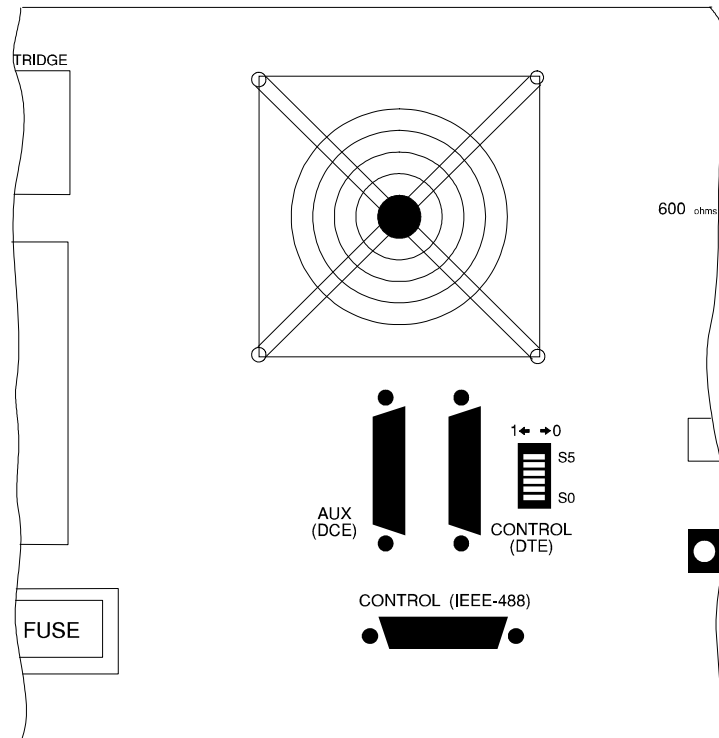

Figure 2-3. Station Interface in 4-Wire Configuration

## 2.2.2. Rear Panel Controls, Jacks and Ports

The rear panel contains a remote control interface (consisting of a switch and three connectors), the AC power entry module and switch, a Memory Cartridge receptacle, a fan, two scope monitor BNC connectors, two modular RJ-45 type receptacles, two terminal strips which present internal points to the user, and two pairs of a trigger input and a sync output connector. The detailed functionality of each of these is explained below.



**Figure 2-4. Remote Control Interfaces**

### Remote Control Interface

The remote control interface on the rear panel consists of the three connectors and one DIP switch residing directly beneath the fan assembly (see Figure 2-4). The connectors are labeled "AUX (DCE)", "CONTROL (DTE)", and "CONTROL (IEEE-488)", and the switch is labeled S0-S5.

### **RS-232C CONTROL (DTE) Port**

The CONTROL (DTE) port is a 25 pin D-sub connector which supports RS-232C. The control port is wired as a Data Transmission Equipment (DTE). All RS-232C remote control of the Series II must be done via this port. An RS-232C terminal or a PC (IBM compatible) can control the TAS Series II through this port via a null modem cable (a sample null modem is provided with any Series II). Two protocols are supported in RS-232 control mode, ACK/NAK (ACKnowledge/Negative AcKnowledge, and CR/LF (Carriage Return/Line Feed). Both of these protocols are explained in full detail in the PROGRAMMER'S GUIDE section of this manual.

### **RS-232C AUX (DCE) Port**

The AUX (DCE) port (auxiliary) is a 25 pin D-sub connector which supports RS-232C. The auxiliary port is wired as a Data Communications Equipment (DCE). The auxiliary port is reserved for future use.

### **CONTROL (IEEE-488) Port**

The CONTROL (IEEE-488) port is a 24 pin IEEE-488 receptacle which supports the IEEE-488 (GPIB) protocol. This port must be connected to an IEEE-488 controller to control the Series II via IEEE-488. This connection may be either direct or via a multi-point bus which contains other IEEE-488 controlled equipment.

The IEEE-488 controller may be a generic PC with an embedded IEEE-488 control card installed, a IEEE-488 computer, an RS-232 to IEEE-488 converter, or some other IEEE-488 controller. For an installation which includes a TAS Gemini and TASKIT software the Gemini serves as the IEEE-488 controller.



### Configuration DIP Switch

Once a control mode has been determined, the Series II DIP switch on the rear panel must be programmed to expect that protocol. The switches are used to indicate not only the protocol, but all other information which is programmable. The information below details the switch settings:

S5	S4	S3	S2	S1	S0	CONTROL MODE															
0	1	b1	a2	a1	a0	<b>RS-232 ACK/NAK</b>  b1 = 0 → 4800 bps b1 = 1 → 9600 bps  a2,a1,a0 = Address (binary weighted with a2 as MSB), valid range from 0-7.															
0	0	0	0	b2	b1	<b>RS-232 CR/LF</b>  <table border="1"> <thead> <tr> <th>b2</th> <th>b1</th> <th>Bit rate</th> </tr> </thead> <tbody> <tr> <td>0</td> <td>0</td> <td>1200 bps</td> </tr> <tr> <td>0</td> <td>1</td> <td>2400 bps</td> </tr> <tr> <td>1</td> <td>0</td> <td>4800 bps</td> </tr> <tr> <td>1</td> <td>1</td> <td>9600 bps</td> </tr> </tbody> </table>	b2	b1	Bit rate	0	0	1200 bps	0	1	2400 bps	1	0	4800 bps	1	1	9600 bps
b2	b1	Bit rate																			
0	0	1200 bps																			
0	1	2400 bps																			
1	0	4800 bps																			
1	1	9600 bps																			
1	a4	a3	a2	a1	a0	<b>IEEE-488</b>  a4 thru a0 = Address (binary weighted with a4 as MSB), valid range from 0 to30.															

**Table 2-1. DIP Switch Configurations**

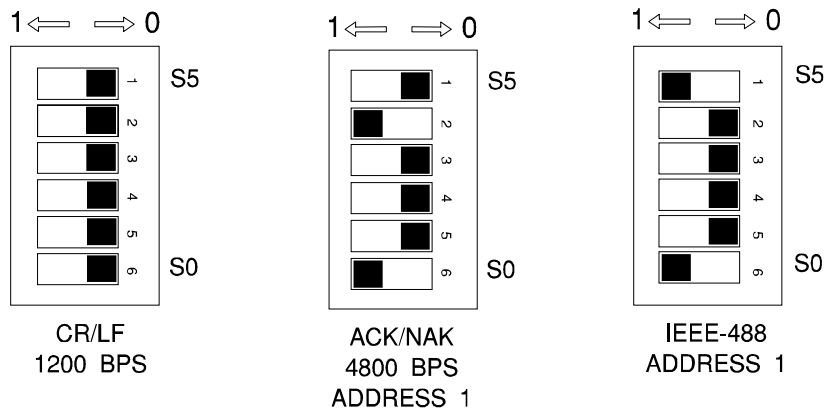

**Figure 2-5. Examples of Configuration DIP Switch Settings**

Figure 2-5 illustrates typical configuration switch settings, including an example for each one of the three transmission layer protocols.

The TAS Series II reads the configuration switches during system initialization. To enforce a change in the dip switch settings, you must cycle the AC power after the switch settings have been changed.

### RS-232C ACK/NAK Protocol Configuration Switch Setup

When the control mode is RS-232 ACK/NAK the user must program two additional parameters, the bit rate and the address.

The baud rate of the Series II for RS-232 ACK/NAK is controlled by switch S3 (b1). The switch S3 (b1) controls the port bit rate as follows:

0	4800 bps
1	9600 bps

The address of the Series II for RS-232 ACK/NAK is controlled by switches S2 (a2), S1 (a1), and S0 (a0).

a2, a1, a0 = the station address in binary (0-7)

For ACK/NAK protocol the Series II expects the data format to be 7 bits/character, odd parity, and 1 stop bit.

The ACK/NAK protocol should only be used if the environment may cause errors on the transmission link (ACK/NAK protocol has built-in error detection capabilities), or multiple units are to be controlled from one controller. The multipoint capability of the ACK/NAK protocol requires the use of a port sharing device (contact TAS customer service for more information). This feature will allow for control of up to eight Series IIs (each with its own unique ACK/NAK address) from a single RS-232 controller port.

### RS-232C CR/LF Protocol Configuration Switch Setup

When the control mode is RS-232 CR/LF there is one additional parameter to set, the bit rate. The Series II expects the data format to be 7 bits/character, odd parity, and 1 stop bit. The bit rate is selected via the switches S1 (b2), and S0 (b1), the selections are:

b2	b1	Rate
0	0	1200 bps
0	1	2400 bps
1	0	4800 bps
1	1	9600 bps

## IEEE-488 (GPIB) Protocol Configuration Switch Setup

When the control mode is IEEE-488 the user must program one additional parameter, the bus address of the Series II.

The address of the Series II for IEEE-488 is controlled by switches S4 (a4) to S0 (a0).

a4, a3, a2, a1, a0 = the station address in binary 0 - 30 (00000 - 11110)

## AC Power Switch

The AC power switch is located at the lower left of the rear panel (as viewed from the rear of the unit). Push this switch to turn the AC power on or off.

## AC Power Receptacle

The AC power receptacle is located on the left rear portion of the rear panel. This receptacle also contains the fuse for the unit. The TAS Series II unit is factory-set for a customer's local power. If it becomes necessary to change that setting, the proper procedure for performing the operation is described below:

1. Remove the power cord and move the plastic slide to the left to reveal the fuse and power selector board (present setting of 100 or 240 should be visible).
2. Pull out the power selector board and then reinsert it for the desired setting (That setting should be facing up and readable after insertion).

## Software Cartridge Port

A software cartridge port is located at the upper left of the rear panel. The TAS Series II Program Memory Cartridge, which contains the TAS Series II control program, must be inserted into this port before power is turned on.

<p><b>CAUTION:</b> Do not install or remove the Program Memory Cartridge while the power is on.</p>
---

## Signal Input/Output Connectors

There are several connectors located on the rear on the Series II on the right hand side of the panel (see Figure 2-6). The functions of each of these connectors is described below.

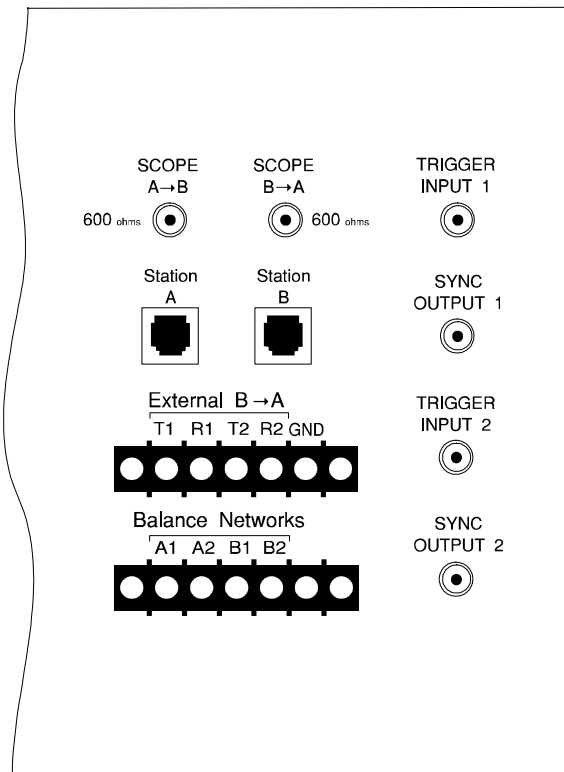

**Figure 2-6. Rear Panel Signal I/O Connectors**

### Trigger Input and Sync Output Jacks

Two pairs of trigger and sync jacks are provided on the rear panel. These jacks are designated as TRIGGER INPUT 1, SYNC OUTPUT 1, TRIGGER INPUT 2, and SYNC OUTPUT 2. TRIGGER INPUT 1 and SYNC OUTPUT 1 are dedicated to Impairments Generator 1 (A to B), and TRIGGER INPUT 2 and SYNC OUTPUT 2 are dedicated to Impairments Generator 2 (B to A).

TRIGGER INPUT 1 and 2 can be supplied with TTL inputs which may be used as a trigger for the TAS Series II internal impulse noise generator. The TAS Series II only uses these inputs as the trigger when the external trigger or external single shot trigger mode is selected. If used, the impulse is triggered on the falling edge of the input signal. When using external triggering, the TAS Series II allows for a user programmed trigger delay interval.

TTL pulses are provided on the SYNC OUTPUTS by the internal impulse generators. These outputs are provided independently of the selected trigger mode. The output signals are synchronized to the impulse events occurring on the line, and they can be used to synchronize other instruments (i.e., storage scope) to the impulses.

### **Station A and B Modular Jacks**

Station A and station B modular telephone jacks are located in the middle of the right-hand side of the rear panel. These jacks are connected in parallel with the front panel jacks and are configured identically. The pin out for these connectors is shown in figures 2-2 and 2-3.

### **External B→A (B to A Path Breakout Terminal Strip)**

The external B to A terminal strip is located near the bottom of the right side of the rear panel. By enabling the "external reverse channel" command (see the "/LC,Ee/" command in PROGRAMMER'S GUIDE section of this manual), the signals in the B to A direction through the transmission channel are presented on this terminal strip. The signal path through the Series II is completely broken to allow the insertion of additional impairments to the signal. The output of the Series II B to A transmission channel is provided on the pins labeled "T2" and "R2", and the input signal should be provided back into the Series II on the pins labeled "T1" and "R1". The nominal signal level at the output pins will be the output level currently set for the B to A direction, the level of the input signal returned to the Series II will determine the output level of the Series II at the front (and rear) station B modular jack. See "B to A Channel Access" in the Central Office portion of this section.

### **Balance Networks Terminal Strip**

The balance networks terminal strip is located on the right side of the rear panel. This terminal strip provides the means to substitute other hybrid balancing impedances for those internal to the TAS Series II. Nominally the Series II provides a 604 ohm balance impedance. See "Hybrid Balance" in the Central Office portion of this section.

### **Scope A→B and Scope B→A Connectors**

Two BNC ports are provided on the rear panel for monitoring signals which normally may not be presented to the user. Designated SCOPE A→B and SCOPE B→A, they are located near the top of the right side of the rear panel. The TAS Series II can be directed to select and provide internal signals at this BNC-type jack for external monitoring. The following signals (see Figures 2-2 and 2-3) may be selected:

A→B SCOPE:

- a xmit (A0): transmit level of the equipment connected to station A. This signal is monitored on the four wire side of the hybrid.
- b rcv 4w (B1): signal level received at the station B 4-wire point.
- b rcv 2w (B2): signal level received at the station B 2-wire point. This signal is monitored on the four wire side of the hybrid.

B→A SCOPE:

- b xmit (B0): transmit level of the equipment connected to station B. This signal is monitored on the four wire side of the hybrid.
- a rcv 4w (A1): signal level received at the station A 4-wire point.
- a rcv 2w (A2): signal level received at the station A 2-wire point. This signal is monitored on the four wire side of the hybrid.

An audible representation of the selected A→B or B→A signal is available on the internal speaker.

### 2.2.3. Remote Control Features

The TAS Series II may be controlled remotely by either RS-232, or IEEE-488. Two protocols are available under RS-232 control, ACK/NAK (ACKnowledge/Negative ACKnowledge) for use in situations where error detection is required such as control via modems, and CR/LF for use where error detection is not required. ACK/NAK also supports control of multiple simulators from the same master communications port. The IEEE-488 protocol is only used when controlled by a IEEE-488 controller.

The command structure used to control the Series II is independent of the control mode or protocol. A typical command for the Series II would contain a function (group) id followed by one or more parameter ids with associated data.

There are a few special commands and control features which are described here. The Series II supports several test channel configurations which differ in the impairments which are available to the user, and the ordering of the impairments. The user may program the parameters for all impairments at any time regardless of whether the impairment is currently supported. These parameters will take effect once the channel configuration is changed to one which includes that impairment.

The Series II supports several "software straps" which set some operational characteristics of the Series II (refer to the command summary, AD commands for more details). Among these are the selection of IEEE impulses or bipolar impulses. These straps are reset to the factory default by the "soft reset" command and at power-up.

Finally the Series II (PMC version 1.3 and above) supports "parameter readback" of any user programmable parameter. This feature allows the user to poll the Series II to determine the setting of any parameter.

Refer to the command summary for detailed information on the protocols, command structure, and specific commands.

## 2.3. Channel Access Module (Optional)

System requirements include the following:

- TASKIT Software: Version 4.50 or higher
- TASKIT for Windows Software: Version 1.0 or higher
- Series II Program Memory Cartridge: Version 1.30 or higher
- Network Interface Module (NIM) 2B: Version 1.30 or higher

### 2.3.1. CAM Module

The Series II optional Channel Access Module (CAM) provides the means to obtain 4-wire access to the transmit and receive ports of the A→B and B→A transmission channels when the Series II is configured for 2-wire operation. With the CAM it is possible to perform the following functions:

1. Cascade external transmission or simulation equipment with the internal transmission channels of the Series II.
2. Access all four ports of the Series II 2-wire to 4-wire hybrids including the transmit and receive 4-wire ports.
3. Simulate a 4-wire switched network configuration.

A 600 ohm differential input interface along with a 600 ohm balanced output interface is provide at the 4-wire transmit port and at the receive port of each hybrid. These interfaces are available on the left side of the Series II rear panel as illustrated in Figure 2-7. Two 8 pin modular jacks labeled CAM A and B provide access to the station A and station B ports respectively. The signals available on modular jack A are listed in the second column of Table 2-2 and the signals available on modular jack B are in the third column.



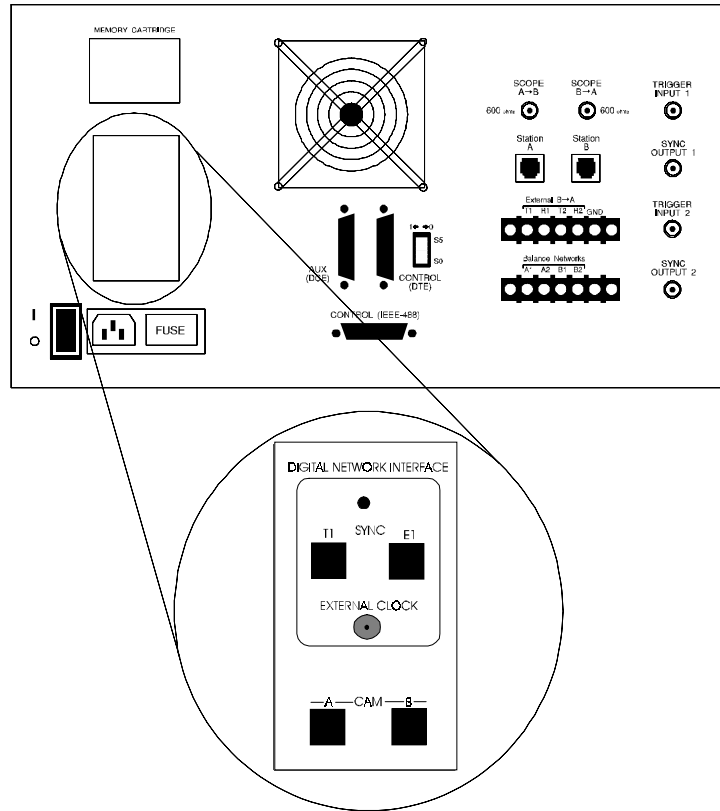

**Figure 2-7. Rear Panel Channel Access Module Connectors**

Pin #	CAM A Modular Jack	CAM B modular Jack
1	Station A receive output ring conductor	Station B receive output ring conductor
2	Station A receive output tip conductor	Station B receive output tip conductor
3	Station A receive input tip conductor	Station B receive input tip conductor
4	Station A transmit input ring conductor	Station B transmit input ring conductor
5	Station A transmit input tip conductor	Station B transmit input tip conductor
6	Station A receive input ring conductor	Station B receive input ring conductor
7	Station A transmit output tip conductor	Station B transmit output tip conductor
8	Station A transmit output ring conductor	Station B transmit output ring conductor

**Table 2-2. Channel Access Module Interface Summary**

Figure 2-8 provides a high level view of the location of the optional CAM interfaces, in addition to the standard B to A access interface.

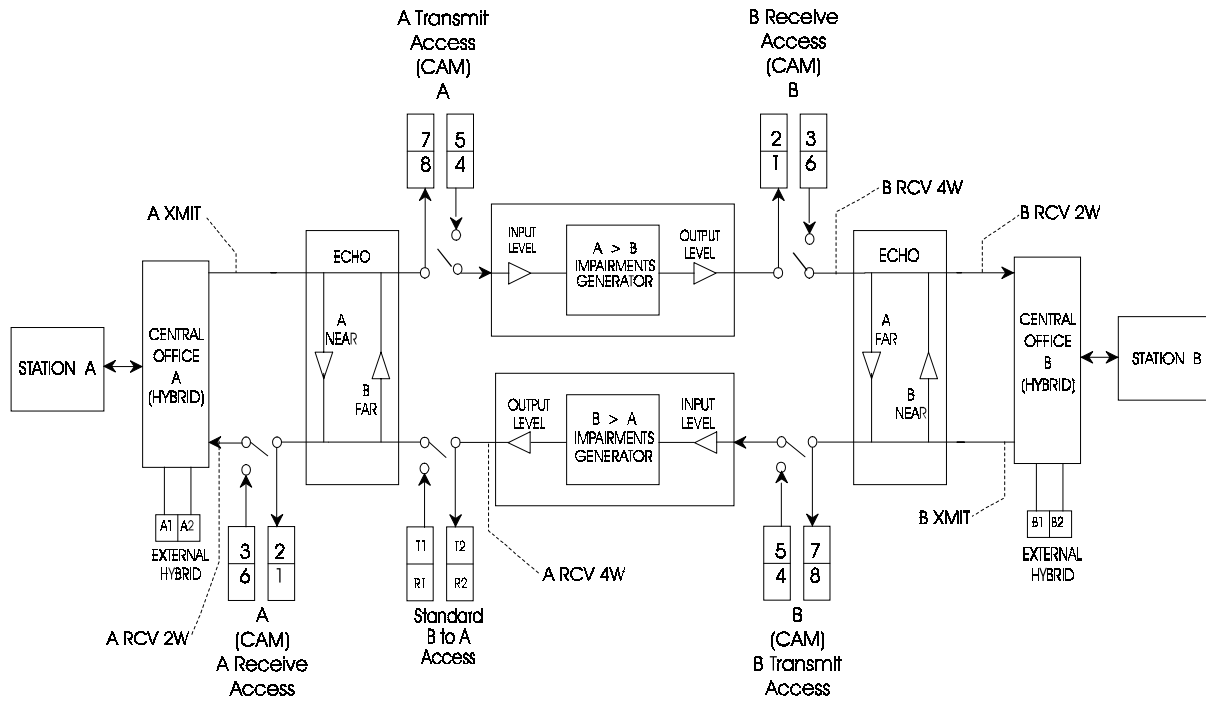
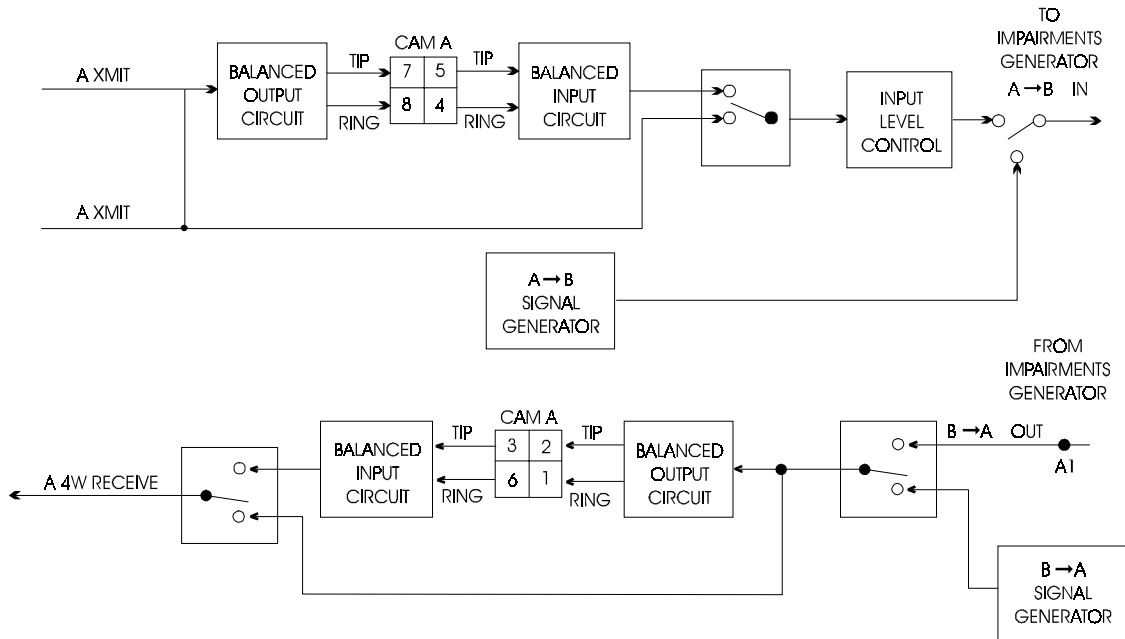
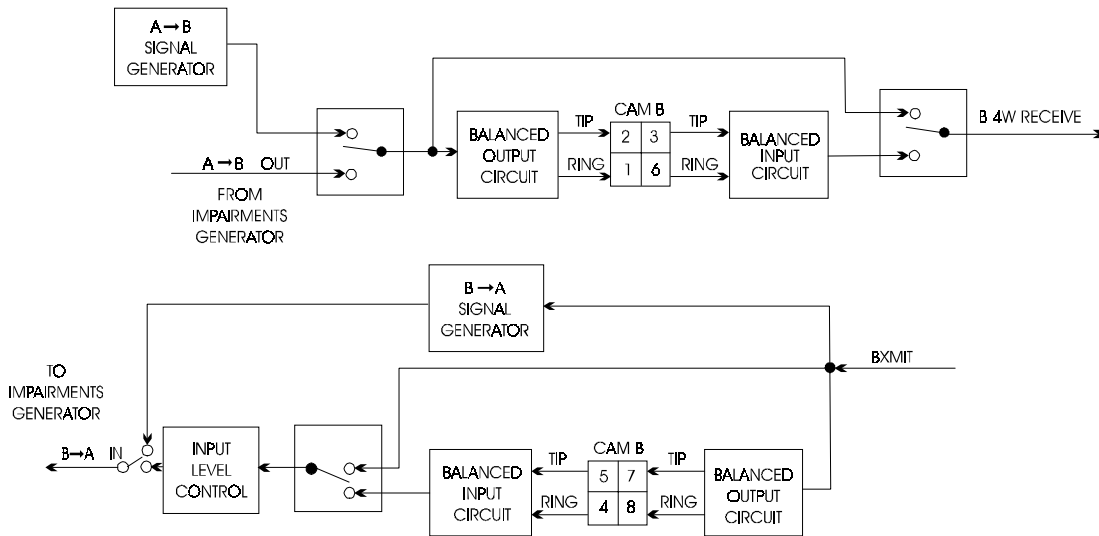

Figure 2-8. Optional CAM Interfaces

Figure 2-9 shows the location of the CAM A signals and Figure 2-10 shows the CAM B signals. To use one of the access interfaces provided by the CAM, the interface must be enabled with the LC,A command. To insert an external device in series with the internal transmission channels of the Series II, the CAM interface signals designated as outputs should be connected to the input of the external device, and the CAM signals designated as inputs connected to the output of the external device. The use of Line Interface Adapters is recommended to facilitate easy access to the modular jack pins for the relevant tip and ring combinations.



**Figure 2-9. Station A CAM Interfaces**

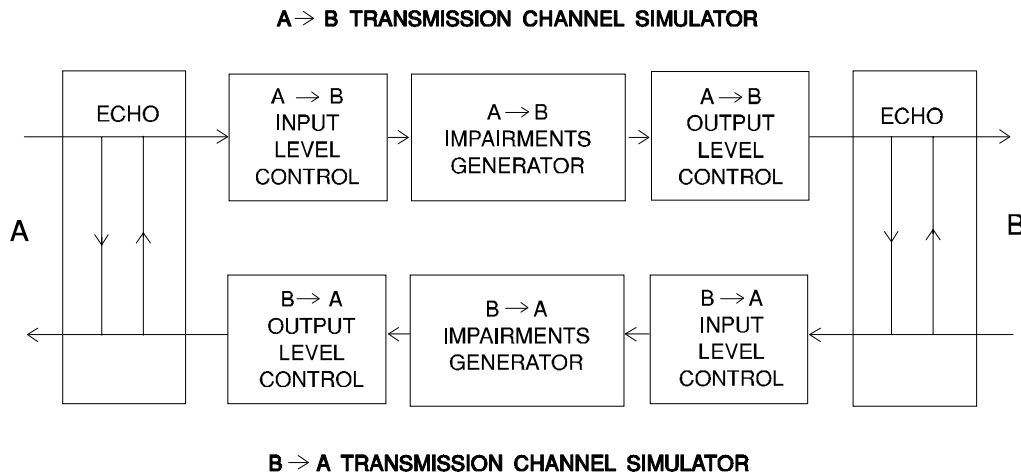

**Figure 2-10. Station B CAM Interfaces**

A 4-wire switched network configuration may be created by enabling both the station A and station B transmit CAM interfaces. The transmit (output) tip/ring signal pair of the 4-wire switched communications equipment (telephone or modem) at station A should be connected to pins 5 and 4 of CAM A jack on the Series II rear panel ( - use of a Line Interface Adapter is recommended for simplified access to pins). Pins 5 and 4 of the Series II station A modular jack should connect to the receive (input) tip/ring pair of the station A 4-wire equipment. Likewise, the transmit (output) tip/ring signal pair of the 4-wire switched communications equipment at station B should be connected to pins 5 and 4 of CAM B jack on the Series II rear panel. Pins 5 and 4 of the Series II station B modular jack should connect to the receive (input) tip/ring pair of the station B 4-wire equipment. This setup will supply loop current for hook status detection, ringing and call progress tones to the receive pair (pins 5 and 4 of the modular jack) only of the 4-wire communications device. However, the device must transmit its DTMF (touch-tone) dialing information on the transmit pair.

## 2.4. Transmission Channel (Trunk) Simulator

A high level block diagram of the transmission channel simulator of the Series II is shown in Figure 2-11. The transmission channel consists of an input level control, an optional impairments generator (including echo), and an output level control. A single transmission channel processes signals in only one direction at a time. All TAS Series II units are equipped with two transmission channel simulators and an impairment generator in each channel.



**Figure 2-11. Transmission Channel Simulator Block Diagram**

The impairment generator is capable of simulating a wide variety of voiceband impairments. These impairments are divided into analog, digital, and echo. Analog impairments are those which affect the signal during transmission on analog facilities such as noise and frequency shift. Digital impairments are those which are experienced due to transmission on digital facilities. The digital impairments of the Series II are PCM/ADPCM, bit errors, frame slips, and robbed bit signaling. Echo results from the impedance mismatches which occur at analog interfaces.

A major feature of the Series II is the ability of the impairment generator to simulate many different impairment configurations (or topologies) without any hardware changes. These different impairment configurations arise from the many organizations around the world independently specifying test conditions for modems and other voice band transmission devices. These organizations include (but are not limited to) the EIA, ETSI, and other independent PTTs. The configurations provided by the Series II are discussed below in detail. Configuration changes are implemented by issuing a command to the Series II.

### **2.4.1. Test Channel Configuration Programming**

The test channel configuration of the Series II is defined by the impairments which are available, the order in which the impairments are presented to the incoming signal, and the background conditions generated by those impairments. The Series II supports three different configurations, one representing the network defined by the EIA and CCITT (designated EIA), a second representing the network defined by the ETSI as test line 1 (ETSI-1), and the third configuration represents the ETSI test line 2 (ETSI-2). See Figures 2-12 through 2-15 for detailed diagrams of these configurations.

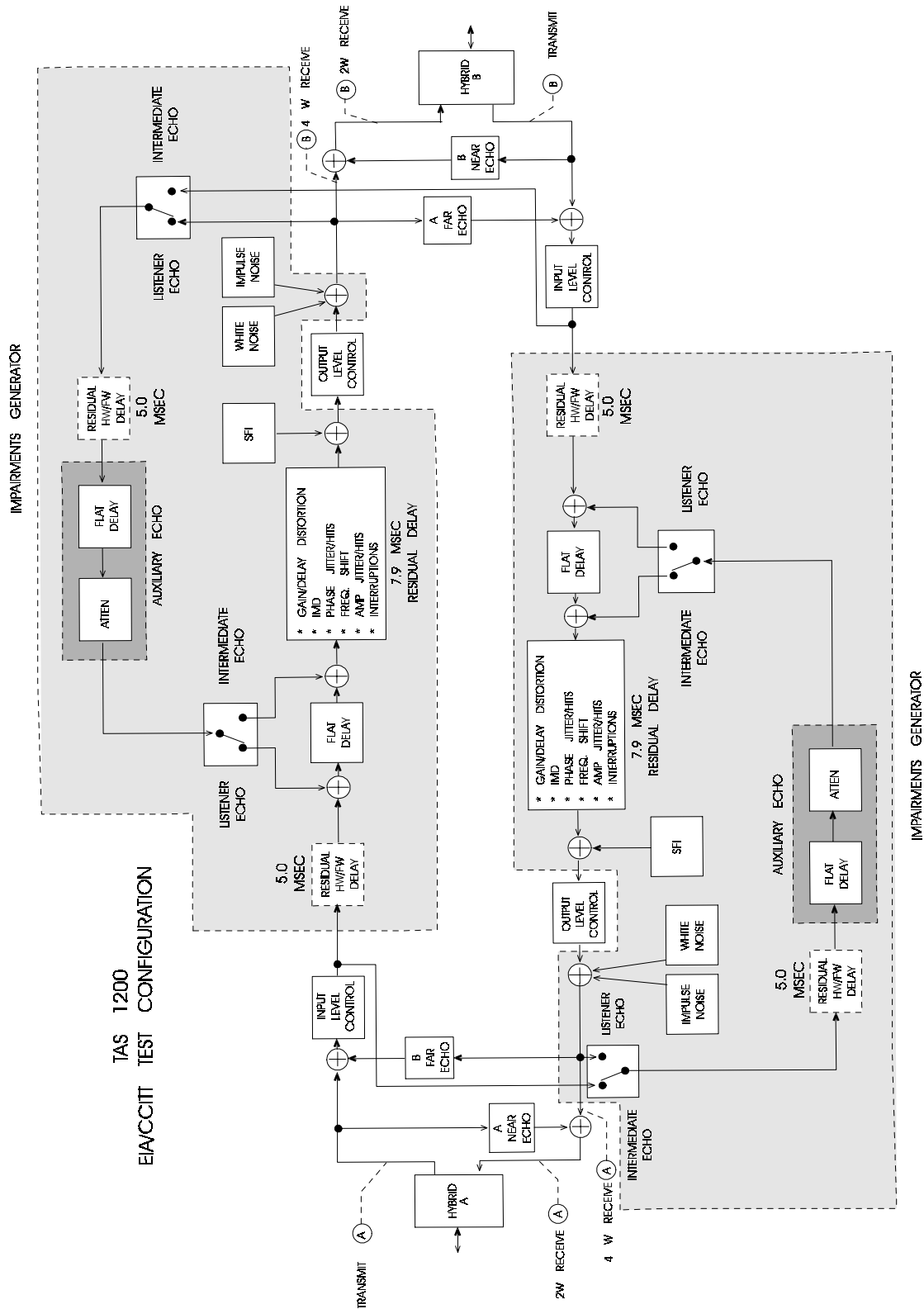

Figure 2-12. TAS Series II EIA/CCITT Test Configuration

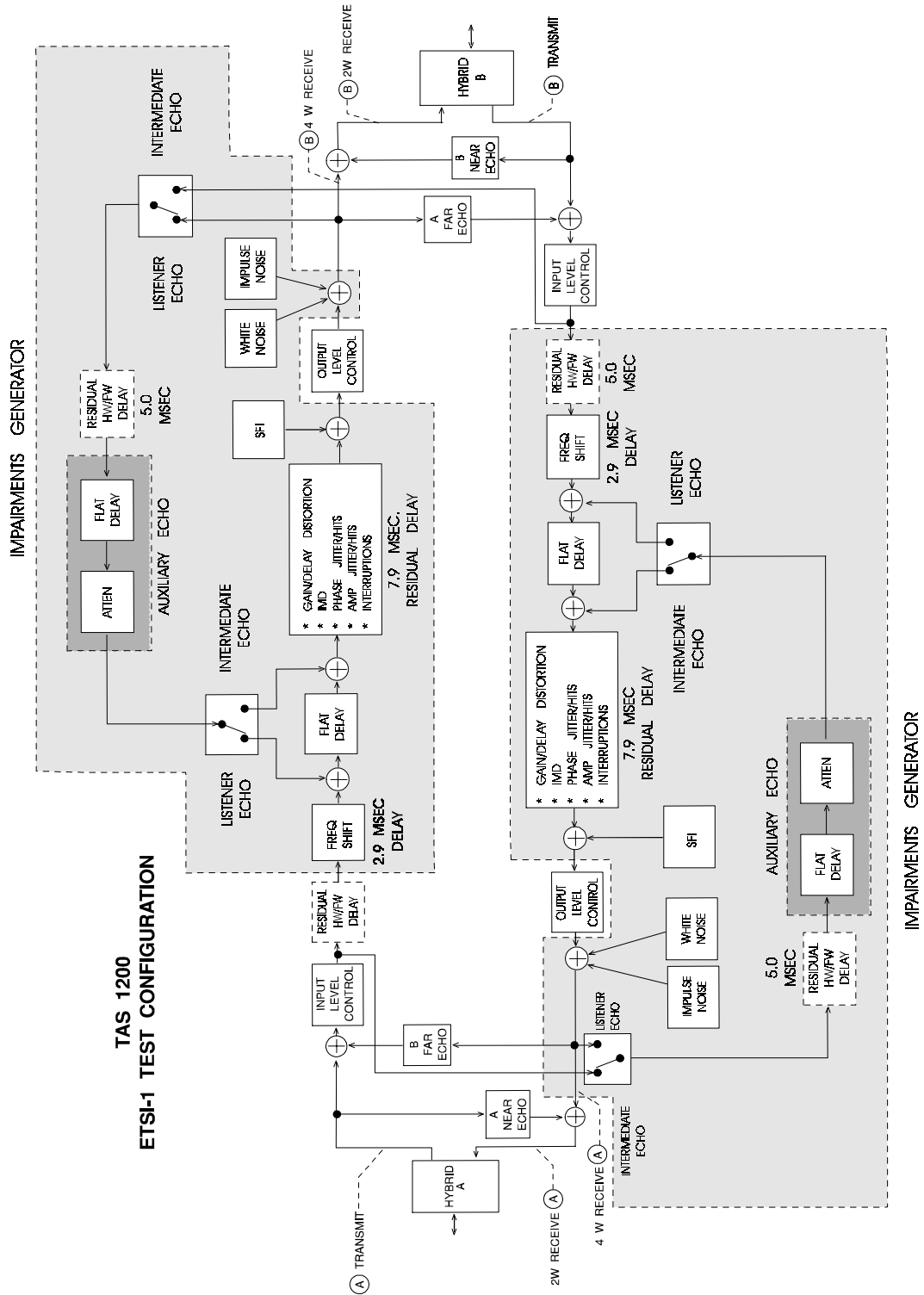

Figure 2-13. TAS Series II ETSI-1 Test Configuration



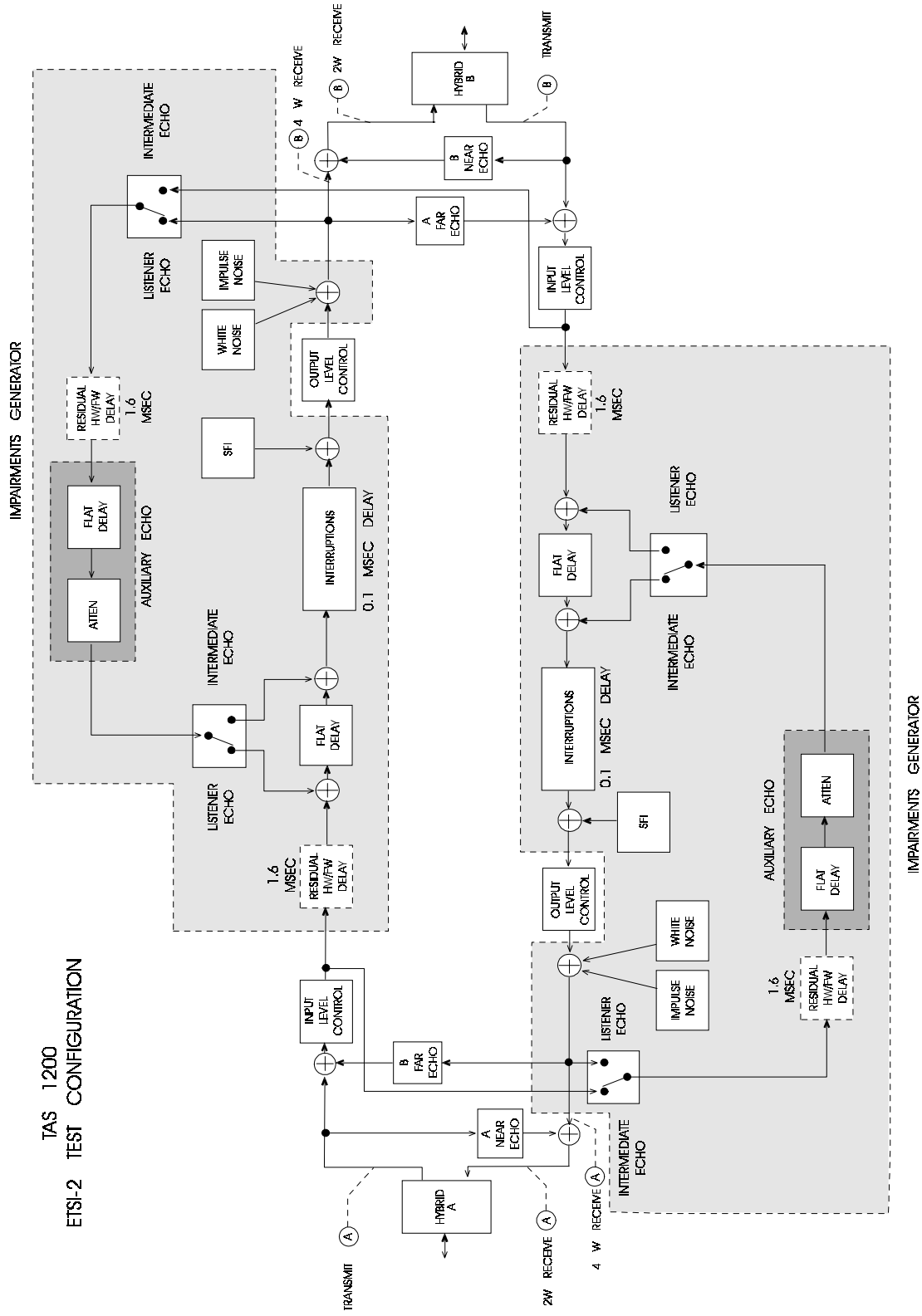
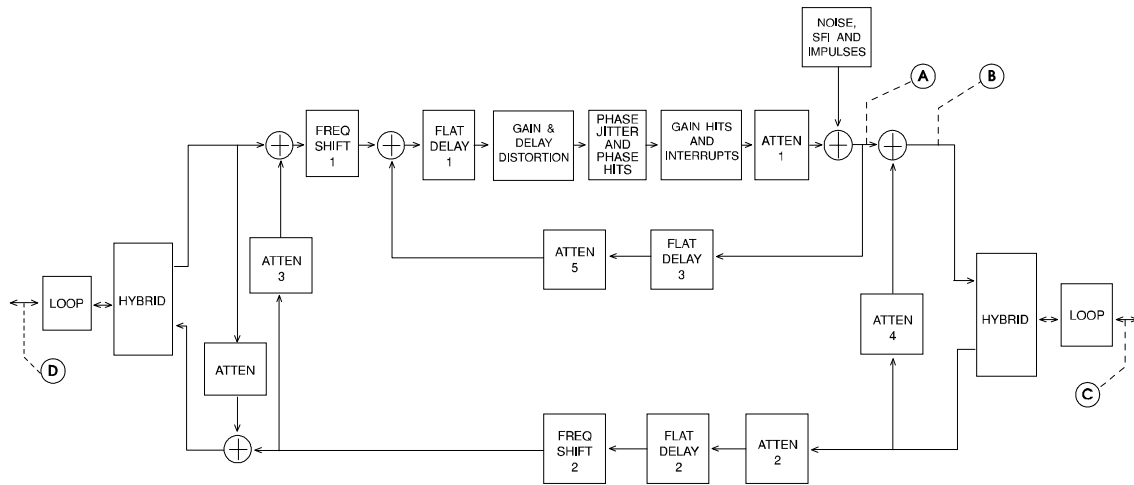

Figure 2-14. TAS Series II ETSI-2 Test Configuration



**Figure 2-15. ETSI NET 20 Test Bench**

Table 2-3 details the impairments which are present in each of the three configurations. Note that configuration ETSI-2 has limited the number of impairments present in the simulation. This is due in part to the requirements of the ETSI NET 20 regarding the delay experienced from end to end. Each of the impairments will be discussed fully in proceeding sections.

<b>Impairment</b>	<b>EIA/CCITT</b>	<b>ETSI-1</b>	<b>ETSI-2</b>	<b>Analog Bypass</b>
Amplitude Jitter	Yes	Yes	No	No
Frequency Shift	Yes	Yes	No	No
Gain/Delay Distortion	Yes	Yes	No	No
Gain Hits	Yes	Yes	No	No
Impulse Noise (IEEE)	Yes	Yes	Yes	No
Impulse Noise (Bipolar)	Yes	Yes	Yes	No
Interruptions 1	Yes	Yes	No	No
Interruptions 2	No	No	Yes	No
Non-linear Distortion (IMD)	Yes	Yes	Yes	No
Phase Hits	Yes	Yes	No	No
Phase Jitter	Yes	Yes	No	No
Single Frequency Interface (SFI)	Yes	Yes	Yes	No
White Noise	Yes	Yes	Yes	Yes
Auxiliary Echo 1 (Listener or Intermediate)	Yes	Yes	No	No
Auxiliary Echo 2 (Listener or Intermediate)	No	No	Yes	No
Satellite Delay 1	Yes	Yes	No	No
Satellite Delay 2	No	No	Yes	No
Echo - Near	Yes	Yes	Yes	Yes
Echo - Far	Yes	Yes	Yes	Yes
PCM/ADPCM (if present)	Yes	Yes	Yes	Yes

**Table 2-3. Impairment Channel Configuration Definition**

The Series II has two Interruption, Satellite Delay, and Auxiliary Echo generators. However, only one is available in any configuration. The programming for each pair of impairments is completely independent (i.e. the Satellite Delay module 1 parameters are programmed independently from the Satellite Delay module 2 parameters). The parameters for any impairment generator may be programmed even though that module may not be present in the current configuration (i.e. Satellite Delay 2 parameters may be programmed while current configuration is EIA). Both IEEE impulse noise and Bipolar impulse noise are shown on the table above, however only one is available at any given time.

## **EIA Test Channel**

The EIA/CCITT test channel configuration is based on the following specifications:

- EIA/TIA-496-A
- EIA TR30.3 "Proposed Test Channels for V.32 and Asymmetrical Modems"
- EIA/TIA Technical Bulletin (PN 2825)
- CCITT Study Group XVII TD-237

## **ETSI Test Channel 1**

The ETSI test channel 1 configuration is identical to the EIA test channel with only two differences:

- Frequency shift module moved to first module after input control
- The residual propagation delay changes from 12.9 msec to 15.8 msec

The ETSI test channel 1 is based on the NET 20 specifications. Note that the actual implementation of this test channel is a super-set of the configuration in the ETSI document. The Series II implementation however becomes identical to the ETSI configuration when the following impairments are turned off (default state):

A to B Channel:

- Intermodulation Distortion (IMD)
- Amplitude Jitter
- Single Frequency Interference

B to A Channel:

- All impairments except:  
    Frequency Shift  
    Satellite Delay

### ETSI Test Channel 2/3

The ETSI test channel 2 is based on the NET 20 specifications. Note that the actual implementation of this test channel is a super-set of the configuration in the ETSI document. The Series II implementation however becomes identical to the ETSI configuration when the following impairments are turned off (default state):

A to B Channel:

- Auxiliary Echo

B to A Channel:

- All impairments except Satellite Delay

The ETSI test channel 3 configuration is identical to test channel 2 configuration, however the following impairments must be turned off (or not used during test):

- Near Echo
- Far Echo
- Interruptions
- Single Frequency Interference (SFI)
- Impulse Noise
- Random Noise

See application note, "Simulation of ETSI NET 20 Test Bench" for more information.

### 2.4.2. I/O Configurations

The Series II allows two choices for the source of the input signal to the transmission channel simulator, external and internal. The external selection allows the user to input a signal via either the front panel or rear panel jacks. The internal selection uses the Series II internal tone generator as the input signal.

#### Tone Generator

The Series II provides two independent internal tone generators. One generator is dedicated to the A to B transmission channel and the other to the B to A channel. The user may set the frequency of the internal tone sources in 1 Hz steps from 200 Hz to 3400 Hz. The level of the internal tone is preset to 0.0 dBm and is fixed. When internal signal source is selected in the A to B direction of the Series II, the tone source replaces the external user supplied signal. The internal tone source is injected just after the input level control circuit. The tone will transverse all the A

to B impairment modules including the output level control before being received at station B.

When internal signal source is selected in the B to A direction of the Series II, the tone source replaces the external user supplied signal. The internal tone source is injected just after the input level control circuit. The tone will transverse all the B to A impairment modules including the output level control before being received at station A.

### **2.4.3. I/O Level Control**

The input and output level control circuits of the Series II transmission channel simulator provide a number of critical functions for the Series II including input level normalization, and input to output attenuation adjustment. These functions in addition to others will be explained fully below.

#### **Input Level Control**

Each impairment channel of the Series II generates a number of impairments by processing the incoming signal. The levels and other parameters of these impairments can depend on the level of the incoming signal. In order to optimize the accuracy of the impairments the incoming signal level should be normalized. For the Series II this normalized level is 0.0 dBm. The primary function of the input level control sections is to adjust the level of the signal being applied to the Series II to achieve this 0.0 dBm level for the impairment generator. This adjustment may be either gain (increase of the input signal), or attenuation (decrease of input signal level). The Series II provides two methods for control of the input level, direct setting of the "nominal input level", and the "input AGC". Setting the nominal input level results in a single step adjustment or a ramped adjustment while the input AGC results in a ramped adjustment from the current setting to the new.

#### **Nominal Input Level**

To properly set the input level control using the nominal input level the value of the nominal input level parameter must be set to the same level as the signal being applied to the Series II transmission channel. As an example, for a modem with a transmit level of -10.0 dBm connected the Station A port, the A to B nominal input level of the Series II should also be set to -10.0 dBm. This setting will result in a 10.0 dB gain in the input level control block thereby providing a 0.0 dBm signal to the A to B impairment channel.

The nominal input level has two modes of operation, single step and ramped. In the single step mode the new value of input level control is immediately written into the input attenuator. This results in a single step (up or down) in the signal level throughout the channel. If the level of the step is large, modems connected through the channel may experience a gain hit large enough to cause retraining or a disconnect. When the mode is ramped the Series II will "slowly" move the input attenuator from its current setting to the new.

The nominal input level can be set in 0.1 dBm steps from a level of -23.0 to 0.0 dBm.

### **Input AGC**

The input AGC (Automatic Gain Control) is one of the most misunderstood features of the Series II, however it is quite straightforward. Simply put, an input AGC is a method of performing an automatic input level adjustment. When the AGC command (for either the A to B or B to A transmission channel) is given to the Series II, a level measurement is performed on the input signal applied to the input level control circuit for that channel. The nominal input level of that channel is then set (by ramping the attenuation of the input control block either up or down to the new desired level) based on the measured level to provide a normalized signal level (0.0 dBm) into the impairment generator.

The input AGC does not track the input signal over time, it is a one time measure and set sequence. If the input signal changes after the AGC has been performed the resulting level into the impairments generator will not be 0.0 dBm. When the AGC is performed the user should be sure that there is a valid signal applied to the input level control block, if not, the AGC function will fail and an error message will be generated.

When an AGC is performed the nominal input level set by the user is overwritten. Once a new nominal input level is set by the user the AGC will be lost. The input AGC supports an input signal in the range of -23.0 to +7.0 dBm.

Input AGC should be used in applications where the input signal level is not known.

## **Input Level Control Readback**

The Series II allows the user to perform a read back of the setting of the input level control. This is useful after performing an input AGC for allowing the user to determine the precise amount of gain or attenuation being applied to the input signal and the far echo signal. The number returned to the user after performing the readback command is in units (dB) of attenuation, that is a negative number for the input level control readback indicates that there is gain being added to the input signal.

## **Output Level Control**

The setting of the output level determines the level of the signal transmitted out of the Series II for that direction (A to B or B to A). The difference between the input level and the output level determine the loss of the transmission channel. As an example, to establish a channel with 20.0 dB of loss using a modem which transmits at -10.0 dBm, the nominal input level should be set to -10.0 dBm, and the output level should be set to -30.0 dBm. There are two methods for setting the output level, directly via the output level command, and the output (or modem power) AGC.

## **Output Level**

The output level is controlled by setting the amount of attenuation in the output level control block. This attenuation is set with the assumption that the signal level into the output level control module of the transmission channel simulator is 0.0 dBm (same as the input signal level). This output level is calibrated for a 1004 Hz signal. In the event the signal through the Series II is a complex signal with energy at frequencies other than 1004 Hz the effects of gain distortion may cause the resulting output power level to be different than the programmed output level. In order to set an RMS output level for a complex signal the output AGC must be used.

The output level has two modes of operation, single step and ramped. In the single step mode the new value of output level control is immediately written into the output attenuator. This results in a single step (up or down) in the signal level at the output of the channel. If the level of the step is large, modems connected through the channel may experience a gain hit large enough to cause retraining or a disconnect. When the mode is ramped the Series II will "slowly" move the output attenuator from its current setting to the new.



## Output (Modem Power) AGC

The output AGC is very similar to the input AGC described above. When an output AGC is selected on a transmission channel, a true RMS measurement on the signal out of the impairment generator (into the output level control block) is performed, and the output level control attenuator is adjusted accordingly to provide the signal level set by the last output level command. Because the measurement in the Series II is an RMS measurement the resulting output level will be the RMS level as set by the output level command. In order to ensure the end-to-end levels through the transmission channel when an output AGC is performed, an input AGC is also performed. The input AGC precedes the output AGC.

As an example of the effect that an output AGC can have on a signal consider the case when a 2400 Hz signal is applied to the input of the transmission channel at a level of -15.5 dBm. Assume that the last nominal input level was set for -15.0 dBm, and the last output level set was for -20.0 dBm, and also assume that in the channel is a gain shape which attenuates a 2400 Hz signal by 10.0 dB. With no output AGC the following levels will exist:

Input level control input	-15.5 dBm
Input level adjust = +15.0 dB	
Input level control output	-0.5 dBm
(also impairment generator input)	
Impairment generator output	-10.5 dBm
(also output level control input)	
Output level control output	-30.5 dBm
Output level adjust = -20.0 dB	

Due to the 10.0 dBm loss through the impairment channel, the output level will be reduced by the same amount. Once an output AGC (includes an input AGC) has been performed the following levels will exist:

Input level control input	-15.5 dBm
Input level adjust = +15.5 dB	
Input level control output	0.0 dBm
(also impairment generator input)	
Impairment generator output	-10.0 dBm
(also output level control input)	
Output level control output	-20.0 dBm
Output level adjust = -10.0 dB	

After performing the output AGC, the entire channel is properly aligned in terms of the levels at each interface. Both the setting of the input level and the output level controls are modified by the AGC. This amounts to over-riding both the nominal input level, and the output level for the channel. If the user now sets any nominal input level, both the input and output AGCs are lost. The setting of the input level control is determined by the nominal input level value, and the setting of the output level control reverts back to the last output level programmed by the user. If the user sets any output level value only the output AGC is lost, the setting of the output level control is determined by the output level value.

Prior to performing the output AGC white noise in the impairment generator is turned off (if it is on). This ensures that the measured level is adjusted for without adjusting for any power contribution of the noise. This technique will result in a more accurate Signal to Noise ratio (S/N).

### **Output Level Control Readback**

The Series II allows the user to perform a direct readback of the output level control setting. This readback is useful for determining exactly how much modem transmit power is lost in the transmission channel. The result of the output level control readback is in units (dB) of gain, therefore a negative response indicates there is attenuation being added to the transmission signal in the output level control section.

**NOTE:** The EPAL module which emulates the Digital Channel has both input and output level control so the digital channel impairments (including the PAL impairments) can be tested at various signal levels. Both input and output control are referred to as a programmable gain level and default to zero dB of gain. For more information on this refer to the EP command set in the Programmer's Reference section of this manual.

## 2.5. Analog Impairment Generators

Most of the Series II impairments are analog impairments and will be described in terms of their affect on the analog input signal. Internally most of these impairment are however generated using Digital Signaling Processing (DSP) techniques.

Each impairment will be described along with all of the parameters for that impairment.

### 2.5.1. Amplitude Jitter

The amplitude jitter impairment is generated by modulating the level of the input signal. A user selected modulation waveform is generated and used to modulate the level of the input signal. The modulation waveform is an AC signal. The user may program the peak to peak level of the jitter, and the waveform (and frequency) used.

PARAMETER	DEFAULT VALUE	RANGE OF VALUES
Jitter Level	0.0%	0.0 to 98.0%
Frequency	60.0 Hz	0.0 to 300.0 Hz
Modulation Waveform	Sine	Sine, half wave sine, full wave sine, or noise
Status	Off	On or Off

**Table 2-4. Amplitude Jitter Parameter Summary**

**Jitter Level** - The measure of peak-to-peak amplitude jitter in percent (%) of input signal level.

**Frequency** - The frequency of the modulation waveform for the sine, half wave, and full wave waveforms.

**Modulation waveform** - The waveform used to modulate the amplitude of the transmission signal. The selections are a sine wave (sine), a half wave rectified signal (half wave), a full wave rectified signal (full wave), and a 300 Hz band limited noise signal (noise).

**Status** - Turn amplitude jitter on or off.

### 2.5.2. Frequency Shift

The frequency shift impairment modulates the frequency of the input signal by an amount equal to the frequency parameter. This modulation is a fixed (time invariant) amount which is applied equally to all frequency components of the input signal. Frequency shift operates in two modes, one providing approximately +/- 10.0 Hz of shift with a resolution of 0.005 Hz, the other providing approximately +/- 200.0 Hz with a resolution of 0.1 Hz.

PARAMETER	DEFAULT VALUE	RANGE OF VALUES
Frequency (mode 0)	0.0 Hz	-9.995 to +9.995 Hz
Frequency (mode 1)	0.0 Hz	-199.9 to +199.9 Hz
Mode	0	0 or 1
Status	Off	On or Off

**Table 2-5. Frequency Shift Parameter Summary**

**Frequency** - The frequency parameter sets the amount of frequency shift to be applied to the signal. The frequency may be programmed in steps of 0.005 Hz (mode 0), or 0.1 Hz (mode 1).

**Mode** - Select between a high resolution, small range (mode 0), or a low resolution, wide range (mode 1).

**Status** - Turn frequency shift on or off.

### 2.5.3. Gain/Delay Distortion

The Gain and Delay Distortion impairments independently affect the gain or delay versus frequency characteristics of the input signal. The Series II allows for up to two gain distortion curves to be selected at one time, and up to two delay distortion curves to be selected simultaneously. There are approximately 60 gain distortion curves to select from, when two gain curves are active their responses will add. There are approximately 60 delay distortion curves to select from, when two delay curves are active their responses will add.

PARAMETER	DEFAULT VALUE	RANGE OF VALUES
Gain Shape #1	Flat	See above
Gain Shape #2	Flat	See above
Delay Shape #1	Flat	See above
Delay Shape #2	Flat	See above

**Table 2-6. Gain and Delay Distortion Parameter Summary**

**Gain Shapes #1 & #2** - The gain shapes control the gain versus frequency shaping which the input signal is passed through. Each gain shape may be either a flat shape (no shaping) or one of approximately 60 gain filters. The two gain shapes are independent and may be cascaded to form new shapes. The gain shapes are designed to provide linear phase (no delay distortion).

**Delay Shapes #1 & #2** - The delay shapes control the group delay versus frequency shaping which the input signal is passed through. Each delay shape may be either a flat shape (no shaping) or one of approximately 60 delay filters. The two delay shapes are independent and may be cascaded to form new shapes. The delay shapes are designed to be all pass filters (no gain distortion).

The plots of all of the gain and delay shapes are provided in the Technical Specifications section of this manual. Note the there are two sets of the EIA curves for both gain and delay. One set (1010 compatible) represents the curves which were provided in the TAS 1010 Channel Simulator. The second set (enhanced) of curves provide a better response at the low frequencies (below 300 Hz), and the higher frequencies (above 3200 Hz). The selection of which set of curves is selected is controlled by a strapping option as explained in the Programmer's Guide section of this manual (see the /AD,Ss/ command).

## 2.5.4. Gain Hits

Gain hits are temporary changes in the level of the input signal. In the Series II gain hits are generated by modulating the level of the input signal with a trapezoidal waveform. The waveform defines the rise time of the gain hit, the duration, and the interval between hits. The trapezoidal waveform returns to its beginning state. The trapezoid may be positive (signal level increases during hit), or negative (signal level decreases during hit). See Figure 2-16 for the definition of the gain hit waveform.

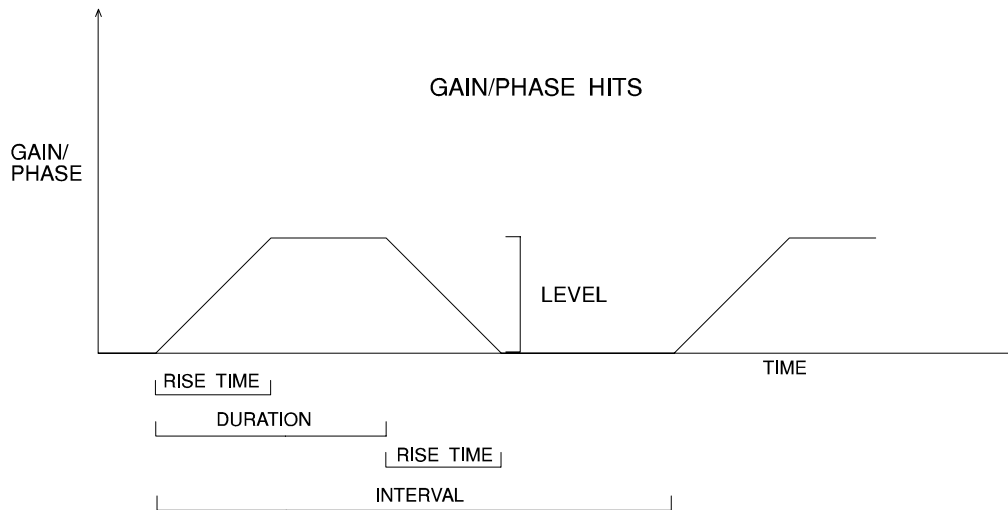

**Figure 2-16. Gain Hit/Phase Hit Modulation Waveform**

PARAMETER	DEFAULT VALUE	RANGE OF VALUES
Level	3.0 dB	-20.0 to +6.0 dB
Rise Time	0.2 msec	0.2 to 990.0 msec
Duration	5.0 msec	1.875 to 20000.0 msec
Interval	1.0 sec	0.1 to 320 sec
Arrival mode	periodic	periodic or pseudorandom
Trigger	N/A	N/A
Status	Off	On or Off

**Table 2-7. Gain Hits Parameter Summary**

**Level** - The measure in degrees of the magnitude of the gain hit. The gain hit level may be positive (increased level) or negative (decreased level).

**Rise Time** - The time of transition from no gain hit to the programmed level of the hit. This time is identical to the rise time of the trapezoidal modulation waveform as measured from the minimum level of the signal to the maximum.

The waveform is completely symmetrical so that the fall time is the same as the rise time.

**Duration** - The time interval measured from the beginning of the gain hit to the start of the removal of the hit. In terms of the modulation waveform this is the time from the start of the ramp up to the start of the ramp down.

**Interval** - The time between the start of one gain hit to the start of the next. In terms of the modulation waveform this is the time from the start of the ramp up of one occurrence to the start of the ramp up for the next. The user must be careful not to program the interval to be any less than the duration plus twice the rise time.

**Arrival mode** - In addition to the interval the arrival mode determines the time between hits. When the mode is periodic the time between hits is always the interval. When the mode is pseudo-random the time between hits is random with a maximum time equal to one-half of the interval setting.

**Trigger** - The trigger command simply causes a single event of the gain hit to occur immediately. The trigger command will begin a gain hit independent of the gain hit status.

**Status** - Turn on or off gain hits.

### 2.5.5. Impulse Noise

There are two impulse noise generators in the Series II impairment generator, an IEEE impulse noise generator, and a bipolar impulse noise generator. Only one generator may be active at any time, the selection is made via one of the strap options as discussed in the PROGRAMMER'S GUIDE section of this manual. The two impulse generators have many parameters of the same name (i.e. level, interval, ...), however the parameters are completely independent. That is the IEEE impulse level may be set and changed at any time without affecting the level of the bipolar impulse. When one impulse type is inactive its parameters may still be programmed without affecting the active impulse type. When the type is changed the last programmed parameters will take affect.

#### IEEE Standard Impulse Noise

The IEEE standard impulse noise is shown in Figure 2-17. The spectral energy of this signal is primarily concentrated in the frequency range below 3500 Hz. Impulse noise with wider band energy may be generated using the bipolar impulse noise generator.

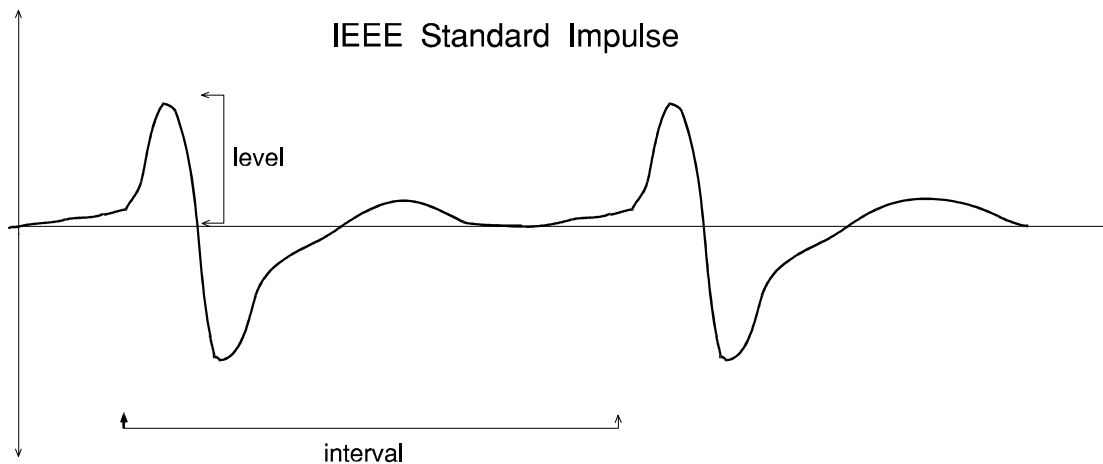

Figure 2-17. IEEE Standard Impulse



PARAMETER	DEFAULT VALUE	RANGE OF VALUES
Level	34.0 dBm	20.0 to 100.0 dBm
Interval	1.0 sec	0.1 to 320 sec
Weighting	C-notch	C-notch
Trigger Mode	Normal	Periodic, pseudorandom,
External Trigger Delay	0.0 msec	0.0 to 80.0 msec
Trigger	N/A	N/A
Status	Off	On or Off

**Table 2-8. IEEE Impulse Noise Parameter Summary**

**Level** - The level of the IEEE impulse noise is defined as the peak level or threshold reached by the impulse as measured after the impulse has been passed through a C-Notch filter.

**Interval** - The interval is defined as the time between successive impulse events.

**Weighting** - The impulse noise weighting is used to adjust the overall level of the impulse to provide a calibrated level for measurement with different filter types. The only supported filter type is the C-notch filter. Note that the weighting parameter does not filter the impulse, it only adjust the level of the impulse shape.

**Trigger Mode** - The trigger mode determines how the individual impulses are triggered. The selections are as follows:

- Periodic trigger mode selects internal timing as the trigger source. Impulses are triggered at periodic interval as defined by the interval parameter.
- Pseudorandom trigger mode also selects internal timing as the trigger source, however the timing between any two impulses is random with the maximum time being equal to one-half of the interval parameter setting.
- External trigger selects an external source as the trigger. The external source is applied through the "TRIGGER INPUT" BNC jack on the rear panel of the Series II. Input 1 is dedicated to impairment generator #1 (normally A-B), and input #2 is dedicated to impairment generator #2. Impulse events will be triggered on each occurrence of a falling edge on the input signal. These inputs are TTL compatible and should not exceed the maximum rate allowed for impulse noise events.
- External trigger single shot is identical to the external trigger mode except that only the first falling edge after the trigger has been armed will cause an impulse, subsequent edges will have no effect until the impulse trigger

has been armed again.. In this mode the trigger command is used to arm the trigger.

**External Trigger Delay** - The external trigger delay is used to set a time interval between the trigger event and the impulse event for externally triggered impulses. This delay is available in both periodic and single shot external trigger modes.

**Trigger** - The trigger command will immediately trigger an impulse event if the trigger mode is either of the two internal selections. The trigger command will begin a impulse independent of the impulse status. If the trigger mode is external the trigger command has no effect, however if the trigger mode is external single shot the trigger command arms the impulse generator to be triggered on the next falling edge of the trigger input.

**Status** - Turn impulse noise on or off.

### 2.5.6. Bipolar Impulse Noise

The ideal bipolar impulse noise shape is shown in Figure 2-18. Due to the bandwidth of the transmission channel and real components (vs. ideal) the actual shape of the impulse noise will have rounded edges and finite rise and fall times.

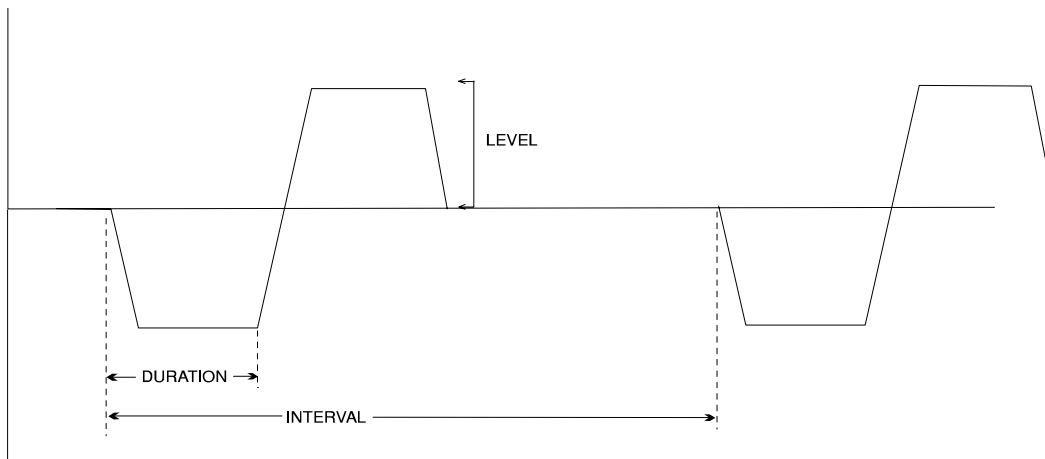

**Figure 2-18. Ideal Bipolar Impulse**

PARAMETER	DEFAULT VALUE	RANGE OF VALUES
Level	-25.0 dBm	-50.0 to +10.0 dBm
Interval	100 msec	1 to 10000 msec
Duration	0.2 msec	0.1 to 10.0 msec
Trigger Mode	Normal	Periodic, pseudorandom,
External Trigger Delay	0.0 msec	0.0 to 100.0 msec
Trigger	N/A	N/A
Status	Off	On or Off

**Table 2-9. Bipolar Impulse Noise Parameter Summary**

**Level** -The level of the bipolar impulse noise is defined as the peak level or threshold reached by the impulse as measured with no additional filtering

**Interval** -The interval is defined as the time between successive impulse events.

**Duration** -The duration of the bipolar impulse is the time from the start of the negative portion of impulse to the start of the positive portion of the impulse. This time is identical to the duration of the negative portion of the impulse.

**Trigger Mode** -The trigger mode determines how the individual impulses are triggered. The selections are as follows:

- Periodic trigger mode selects internal timing as the trigger source. Impulses are triggered at periodic interval as defined by the interval parameter.
- Pseudorandom trigger mode also selects internal timing as the trigger source, however the timing between any two impulses is random with the maximum time being equal to one-half of the interval parameter setting.
- External trigger selects an external source as the trigger. The external source is applied through the "TRIGGER INPUT" BNC jack on the rear panel of the Series II. Input 1 is dedicated to impairment generator #1 (normally A-B), and input #2 is dedicated to impairment generator #2. Impulse events will be triggered on each occurrence of a falling edge on the input signal. These inputs are TTL compatible and should not exceed the maximum rate allowed for impulse noise events.
- External trigger single shot is identical to the external trigger mode except that only the first falling edge after the trigger has been armed will cause an impulse, subsequent edges will have no effect until the impulse trigger has been armed again. In this mode the trigger command is used to arm the trigger.

**External Trigger Delay** - The external trigger delay is used to set a time interval between the trigger event and the impulse event for externally triggered impulses. This delay is available in both periodic and single shot external trigger modes.

**Trigger** - The trigger command will immediately trigger an impulse event if the trigger mode is either of the two internal selections. The trigger command will begin a impulse independent of the impulse status. If the trigger mode is external the trigger command has no effect, however if the trigger mode is external single shot the trigger command arms the impulse generator to be triggered on the next falling edge of the trigger input.

**Status** - Turn impulse noise on or off.

**NOTE:** A ETSI NET 20 compatible impulse will be generated when the duration is set to 0.125 msec.

### 2.5.7. Interruptions (Micro-Cutoffs) 1

Interruptions (or micro-cutoffs) are effectively "breaks" (open circuit) in the transmission path. An interruption is similar to a gain hit without a programmable level, instead interruptions are specified to attenuate the input signal by a minimum of 60.0 dB. Both the duration of each interruption and the interval between interruptions are programmable. Interruption module 1 is only available in channel configurations EIA, and ETSI-1.

PARAMETER	DEFAULT VALUE	RANGE OF VALUES
Duration	10 msec	1 to 20000 msec
Interval	1.0 sec	0.1 to 320.0 sec
Trigger	N/A	N/A
Status	Off	On or Off

**Table 2-10. Interruptions 1 Parameter Summary**

**Duration** - The duration is the length of time from the beginning of the interruption to the end.

**Interval** - The interval is the length of time from the start of one interruption to the start of the next. Note that the interval should be programmed to be larger than the duration to avoid any conflict.

**Trigger** - The trigger command will invoke a single interruption independent of the current status of interruptions (on or off), and independent of the current duration.

**Status** - Turn channel interruptions on or off.

## 2.5.8. Interruptions (Micro-Cutoffs) 2

Interruptions (or micro-cutoffs) are effectively "breaks" (open circuit) in the transmission path. An interruption is similar to a gain hit without a programmable level, instead interruptions are specified to attenuate the input signal by a minimum of 60.0 dB. Both the duration of each interruption and the interval between interruptions are programmable. Interruption module 2 is only available in channel configuration ETSI-2.

PARAMETER	DEFAULT VALUE	RANGE OF VALUES
Duration	10 msec	1 to 6600 msec
Interval	1.0 sec	0.1 to 106.0 sec
Trigger	N/A	N/A
Status	Off	On or Off

**Table 2-11. Interruptions 2 Parameter Summary**

**Duration** - The duration is the length of time from the beginning of the interruption to the end.

**Interval** - The interval is the length of time from the start of one interruption to the start of the next. Note that the interval should be programmed to be larger than the duration to avoid any conflict.

**Trigger** - The trigger command will invoke a single interruption independent of the current status of interruptions (on or off), and independent of the current duration.

**Status** - Turn channel interruptions on or off.

### 2.5.9. Nonlinear Distortion

The nonlinear distortion (NLD) impairment consists of second order and third order components. The second and third order distortions are independent. Second order distortion is generated by squaring the input signal and adding this signal back into the original signal. Third order distortion is generated by cubing the input signal and adding this signal back into the original signal. The measured levels of nonlinear distortion will only be correct when the measurement is performed using the "four tone" technique as defined by IEEE Standard 743-1984.

NLD has two simulation techniques available, the choices are "Proprietary" or "Standard (TAS 1010)". The "Standard (TAS 1010)" selection emulates the implementation provided in the TAS 1010 family of Channel Simulators. For a complex transmission signal such as a modem signal the Proprietary selection typically results in a higher level of IMD (and thus a reduced signal to total distortion ratio) than the Standard (TAS 1010) selection. However the distortion measured using the standard IEEE 4-tone technique will be the same for both selections. The selection of the simulation technique is made via the "/AD,Ss/" command (refer to the PROGRAMMER'S GUIDE section of this manual).

The Series II uses Digital Signal Processing (DSP) techniques to provide all of its transmission impairment simulation including IMD. "Proprietary IMD" as well as most the other impairments are generated at the standard telephone network sampling rate of 8 kHz. But the "Standard (TAS 1010)" IMD is generated at a 16 kHz sampling rate. The sampling frequency has significant impact on the characteristics of the two IMD simulation techniques.

A DSP based system can only support signals that are bandlimited to have a frequency content that is less than half the sampling rate. Signals with frequency components above this limit will cause signal distortion because these signal components are translated (alias) into frequencies that are below the limit (one half the sampling rate).

The frequency content of a voiceband signal resides primarily within the band from 200 Hz to 3500 Hz. Signal components that alias from higher frequencies into this band will cause signal distortion. This phenomenon is the cause of the higher level of total distortion that is generated by the "Proprietary IMD".

Signal components that are at higher frequencies than the original signal are generated when the square (2nd order IMD) and cube (3rd order IMD) operations are performed to simulate the IMD impairment. Forming the square creates a signal with a frequency content that is twice the frequency of the original signal. While the formulation of the signal cube creates a frequency content that is triple that of the original signal. For example, the cube of a 3 kHz signal creates a signal at 9 kHz. A 9 kHz signal can not be supported by a DSP system that has a 8 kHz

sampling rate or 16 kHz and as a result, the signal will alias to 1 kHz in the 8 kHz DSP system and to 7 kHz in the 16 kHz system. The 8 kHz DSP system will experience additional signal distortion because the 1 kHz alias is in the primary frequency band (200 Hz to 3500 Hz). Conversely, the 16 kHz DSP system will not experience an increase in signal distortion because the 7 kHz alias is not in the primary frequency band and because frequencies above 4 kHz are removed by a post processing filter (reconstruction filter).

The "Proprietary IMD" and the "Standard (TAS 1010)" IMD techniques provided by the Series II usually have an equivalent affect on modem transmission performance at speeds of 9.6 kbps and below, and at low IMD levels (40 dB to 60 dB below signal level). The most significant performance difference between the two IMD techniques will be experienced by high speed ( $\geq 14.4$  kbps) modems at high levels (20 dB to 40 dB below signal level) of IMD.

The TAS 1010 Telephone Network Simulator implemented Expansive IMD (Compressive IMD was not supported) with analog signal processing and was not subject to the effects of alias frequencies.

PARAMETER	DEFAULT VALUE	RANGE OF VALUES
2nd Order Distortion Level	52.0 dB	60.0 to 20.0 dB
3rd Order Distortion Level	52.0 dB	60.0 to 20.0 dB
Mode	Expansive	Expansive or Compressive
2nd Order Status	Off	On or Off
3rd Order Status	Off	On or Off

**Table 2-12. Nonlinear Distortion Parameter Summary**

**Level** - The level for both 2nd and 3rd order distortion is in units of dB below the signal.

**Mode** - The mode parameter controls the phase of the distortion relative to the phase of the input signal. When the mode is expansive the distortion signals are added in phase. When the mode is compressive, the distortion signals are added out of phase. This mode has the most effect on 3rd order NLD, because the cube of the input signal results in a component at the fundamental when this signal is added to the input signal that signal is directly effected. The net result is that expansive 3rd order NLD will result in an increase of the fundamental signal while compressive 3rd order NLD will decrease the fundamental.

**Status** - Turn NLD on or off, 2nd and 3rd order are independently controlled.

### 2.5.10. Phase Hits

Phase hits are temporary changes in the phase of the input signal. In the Series II phase hits are generated by modulating the phase of the input signal with a trapezoidal modulation waveform. The waveform defines the rise time of the phase hit, the duration, and the interval between hits. See Figure 2-23.

PARAMETER	DEFAULT VALUE	RANGE OF VALUES
Level	45.0 degrees	0.0 to 180.0 degrees
Rise Time	0.2 msec	0.2 to 990.0 msec
Duration	5.0 msec	1.875 to 20000.0 msec
Interval	1.0 sec	0.1 to 320 sec
Arrival Mode	periodic	periodic or pseudorandom
Trigger	N/A	N/A
Status	Off	On or Off

**Table 2-13. Phase Hits Parameter Summary**

**Level** - The measure in degrees of the magnitude of the phase hit.

**Rise Time** - The time of transition from no phase shift to the programmed level of the phase hit. This time is identical to the rise time of the trapezoidal modulation waveform as measured from the minimum level of the signal to the maximum. The waveform is completely symmetrical so that the fall time is the same as the rise time.

**Duration** - The time interval measured from the beginning of the phase hit to the start of the removal of the hit. In terms of the modulation waveform this is the time from the start of the ramp up to the start of the ramp down.

**Interval** - The time between the start of one phase hit to the start of the next. In terms of the modulation waveform this is the time from the start of the ramp up of one occurrence to the start of the ramp up for the next. The user must be careful not to program the interval to be any less than the duration plus twice the rise time.

**Arrival mode** - In addition to the interval the arrival mode determines the time between hits. When the mode is periodic the time between hits is always the interval. When the mode is pseudo-random the time between hits is random with a maximum time equal to one-half of the interval setting.

**Trigger** - The trigger command simply causes a single event of the phase hit to occur immediately. The trigger command will begin a phase hit independent of the phase hit status.

**Status** - Turn on or off phase hits.



### 2.5.11. Phase Jitter

The phase jitter impairment is generated by modulating the phase of the input signal. A user selected modulation waveform is generated and used to modulate the phase of the input signal. The modulation waveform is an AC signal. The user may program the peak to peak level of the jitter, and the waveform (and frequency) used. The jitter will equally affect all frequency components of the input signal.

PARAMETER	DEFAULT VALUE	RANGE OF VALUES
Jitter Level	0.0 degrees	0.0 to 90.0 degree peak-peak
Frequency	60.0 Hz	0.0 to 300.0 Hz
Modulation Waveform	Sine	Sine, half wave sine, full wave sine, noise
Status	Off	On or Off

**Table 2-14. Phase Jitter Parameter Summary**

**Jitter Level** - The measure in degrees peak to peak, of the amount of jitter (relative to the un-jittered signal).

**Frequency** - The frequency of the modulation waveform for the sine, half wave, and full wave waveforms.

**Modulation waveform** - The waveform used to modulate the phase of the transmission signal. The selections are a sine wave (sine), a half wave rectified signal (half wave), a full wave rectified signal (full wave), and a 300 Hz band limited noise signal (noise).

**Status** - Turn phase jitter on or off.

### 2.5.12. Single Frequency Interference

Single frequency interference (SFI) is an additive impairment which generates a single frequency tone which is added into the output signal. SFI may be added as one fixed tone, or may be programmed to be a frequency swept signal with the start and stop frequencies as well as the increment and sweep interval programmed by the user.

PARAMETER	DEFAULT VALUE	RANGE OF VALUES
Level	10.0 dB (below signal)	0.0 to 50.0 dB (below signal)
Frequency	2600 Hz	16 to 3400 Hz
Frequency Offset	0	0, 1/3, or 2/3 Hz
Sweep Mode	Disabled	Disabled, Single, or Continuous
Sweep Increment	10 Hz	1 to 100 Hz
Sweep Start Frequency	300 Hz	16 to 3400 Hz
Sweep Stop Frequency	3400 Hz	16 to 3400 Hz
Sweep Period	300 sec	1 to 999 sec
Status	Off	On or Off

**Table 2-15. Single Frequency Interference Parameter Summary**

**Level** - The SFI level is presented in terms of the level below the level of the output signal. For example if the output level of the Transmission channel is -10.0 dBm and the level of SFI is 10.0 dB, the actual level of the SFI signal will be -20.0 dBm.

**Frequency** -The frequency is the frequency of the SFI signal added to the transmission path.

**Frequency Offset** -The frequency offset allows for more resolution of the frequency of the SFI. This offset is either 0, 1/3, or 2/3 Hz and is added to the value of the frequency parameter to achieve the actual frequency of the SFI signal.

**Sweep Mode** -The sweep mode determines if SFI consists of a fixed frequency or a sweep of several frequencies. The selections are: no sweep mode (one fixed frequency), a single sweep, and a Continuous sweep. In the Continuous sweep mode the SFI frequency sweeps up to the stop frequency and then sweeps back down to the start frequency.

**Sweep Increment** - The sweep increment is the step size of each frequency step. The total number of steps in the sweep are dependent on the start and stop frequencies as well as the sweep increment.

**Sweep Start Frequency** - The frequency at which the sweep is begun.

**Sweep Stop Frequency** - The frequency at which the sweep stops (single sweep mode), or turns around (Continuous sweep mode).

**Sweep Period** - The time interval over which a single sweep from start to stop frequencies occurs. The period divided by the number of steps (determined by the step size and range) determine the time each frequency is present.

**Status** - Turn SFI on or off.

### 2.5.13. White Noise (Random Noise)

White (or random) noise is an additive impairment and is defined as a signal which has an equal amount of energy at all frequencies within the specified bandwidth of the noise signal. When viewed on a spectrum analyzer the result would be a level versus frequency spectrum which is flat up to the maximum specified frequency.

Impairment measuring test equipment that is designed to IEEE or CCITT standards use an input weighting filter to measure noise. This filter weights (shapes) the noise for a particular frequency band of interest before the noise level is measured. See Figure 2-19 for a diagram of noise measurement setup.

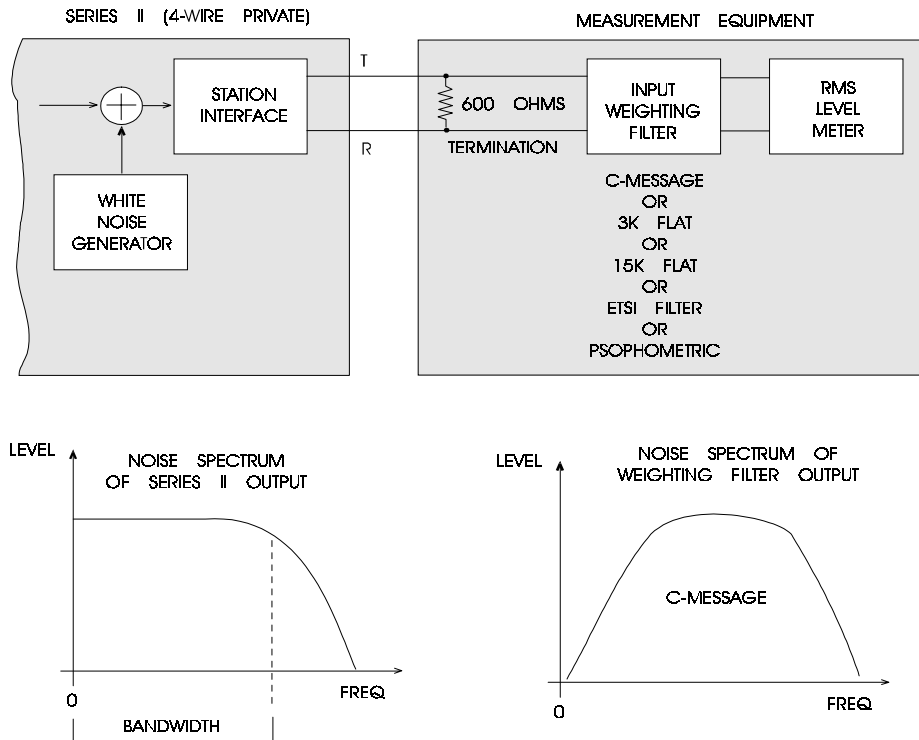

Figure 2-19. Noise Measurement Setup

PARAMETER	DEFAULT VALUE	RANGE OF VALUES
Level	32.0 dBrn	15.0 to 90.0 dBrn
Correction	C-message	C-message, 3 kHz flat, 15 kHz flat, NET20, or Psophometric
Bandwidth	5 kHz	5 kHz, 4 kHz, or 20 kHz
Period	20.97 sec	20.97 sec, or 5.97 hours
Status	Off	On or Off

**Table 2-16. White Noise Parameter Summary**

**Level** - The level of noise is specified in units of dBrn, the conversion to dBm is:

$$\text{level in dBm} = \text{level in dBrn} - 90.0.$$

The level of the noise signal added into the signal path is determined by the level parameter and the setting of the correction factor explained below.

**Level Weighting Correction** - The Series II level weighting correction is an adjustment to the level of the noise spectrum in order to provide correlation between the level of noise generated by the Series II and the level that would be measured by external measurement equipment. When a correction value is selected the level of all frequency components of the noise signal are adjusted (either increased or decreased).

To further explain the concept of the level correction factor consider the following example:

Series II Setup:

- Network configuration: 4-wire private
- Noise level: 60.0 dBrn
- Level correction: C-Message
- All other impairments: off

Measurement Equipment Setup:

- Input termination: 600 ohm
- Weighting Filter: C-Message

This example is illustrated in Figure 2-24. In this situation the measurement equipment would report a noise level of 60.0 dBrn (ignoring tolerances), which corresponds to the level programmed in the Series II. If the weighting filter of the measurement equipment is changed to 3K Flat while the Series II weighting

correction remains set to C-Message, the equipment would then report a noise level of 61.7 dBrn (ignoring tolerances). The increase in the measured noise level is due to the fact that the 3K Flat weighting filter has a larger passband than the C-Message filter. The larger passband allows more noise power to reach the RMS level meter of the measuring set, resulting in a 1.7 dB increase in reported noise level. If the Series II weighting correction is then changed to 3K Flat, the noise generator will reduce (correct) its level by 1.7 dB. The measurement equipment will now again measure 60.0 dBrn (ignoring tolerances).

**Bandwidth** - The noise signal level versus frequency is flat from 0 Hz to the programmed bandwidth frequency (either 4 kHz, 5 kHz, or 20 kHz). Two of the bandwidth selections have a "brickwall" lowpass response with a passband edge frequency of 4 kHz or 20 kHz. The 4 kHz selection has greater than 40 dB of attenuation at frequencies above 5.1 kHz. The 20 kHz selection has greater than 40 dB of attenuation at frequencies above 25 kHz. The third bandwidth selection has 3 dB of attenuation at 5 kHz with a 12 dB per octave of butterworth roll off, and is compatible with the CCITT, EIA and ETSI NET 20 modem test standards.

**Period** - The noise generator is implemented with a digital feedback shift register approach. This approach generates a pseudo-random noise signal with a selectable period of either 20.97 seconds, or 5.97 hours. In general, the 20.97 second sequence will give signal to noise test results that are smoother than the 5.97 hour sequence. The 5.97 hour sequence should be used if the length of the test at each signal to noise value is equal or greater than the 5.97 hour period.

**Status** - Turn noise on or off.

## 2.6. Digital Impairments (PCM/ADPCM Option)

The system requirements are as follows:

- TASKIT for DOS Software: Version 4.32 or higher
- TASKIT for Windows Software: Version 1.0 or higher
- Series II Program Memory Cartridge: Version 1.20 or higher
- PCM/ADPCM Module: Version 1.8 or higher

The TAS Series II optional PCM/ADPCM Links (PAL) module provides the means to test modem performance over various simulated digital transmission systems. With a PAL module it is possible to perform the following functions:

- Simulate up to four tandem, digitally coded transmission links.
- Specify each link as mu-law or A-law, with 64 kbps PCM, 40 kbps ADPCM (CCITT G.723), 32 kbps ADPCM (G.721), 24 kbps ADPCM (G.723), or 16 kbps ADPCM.
- Inject random bit errors on the PCM or ADPCM bit stream of one of the four transmission links.
- Insert PCM robbed-bit signaling on one of the four transmission links (Figure 2-20).

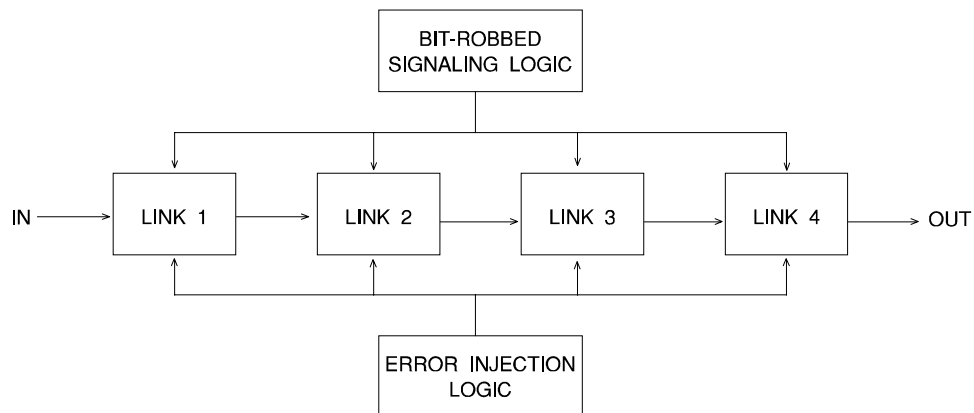

NOTE:

- 1) BIT-ROBBED SIGNALING LOGIC APPLIES TO ONLY ONE LINK AT A TIME.
- 2) ERROR INJECTION LOGIC APPLIES TO ONLY ONE LINK AT A TIME.

**Figure 2-20. PAL Module Block Diagram**

## 2.6.1. PAL Module Features and Application

### Link Selection

The PAL module provides four independently controlled links. A link is defined as one digital coder/decoder pair in the signal path (Figure 2-21) which includes a digital-to-analog conversion followed by an analog-to-digital conversion. The coding always includes 8 bit PCM at a quantizer rate of 64 kbps. If the link has quantizer rates of 40 kbps, 32 kbps, 24 kbps, or 16 kbps, then the data is further coded to ADPCM.

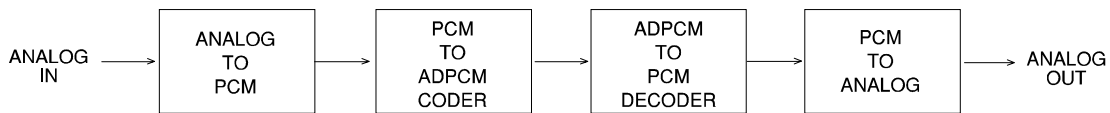

**Figure 2-21. Signal Path Through One Link**

### PCM Coding

The PCM coding feature allows choosing the algorithm used in analog to PCM coding. These algorithms optimize the dynamic range of the analog data sample. Coding can be independently set for each of the four links. The choices are none, mu-law, and A-law.

Both mu-law and A-law compress approximately 13 bits of dynamic range into 8 bits. Mu-law is the compounding characteristic adopted by the U.S. and Japan, while A-law is the compounding characteristic recommended by CCITT.

### Rate

The rate selection allows setting of the rate of serial data throughput on the simulated link. Note that as the required throughput decreases, the number of bits per sample correspondingly decreases. The rate can be independently set for each of the four links. The choices are:

- 64 kbps      8 bit PCM sampled at 8 kHz
- 40 kbps      5 bit PCM sampled at 8 kHz
- 32 kbps      4 bit ADPCM sampled at 8 kHz
- 24 kbps      3 bit ADPCM sampled at 8 kHz.
- 16 kbps      2 bit ADPCM sampled at 8 kHz.

## Error Rate

The error rate selection allows setting of the injected bit error rate on one of the four links. For links using ADPCM, you can inject errors on either the PCM or ADPCM portion of the bit stream (Figure 2-22). Following are choices for error rate:

- Zero
- $2E-20$
- $2E-17$
- $2E-13$
- $2E-10$
- $2E-7$
- $2E-3$

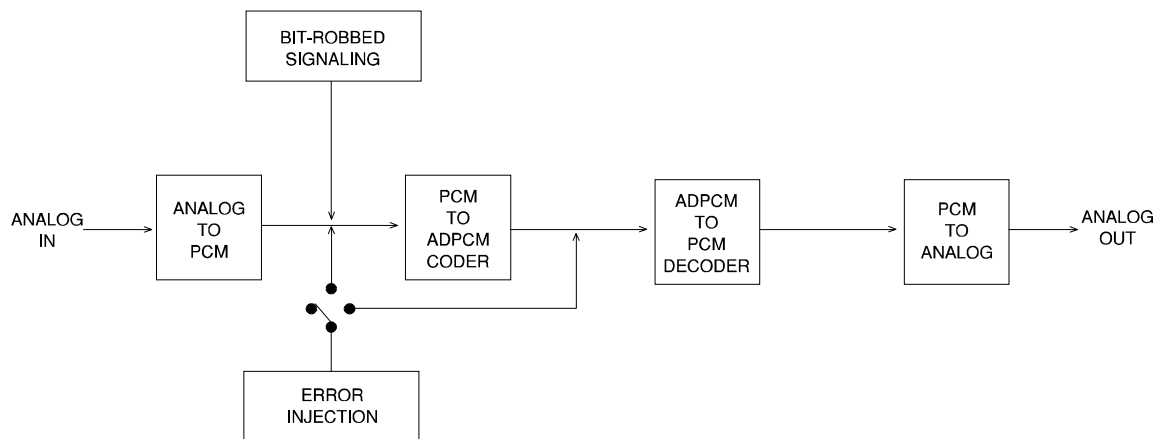

**Figure 2-22. Error Injection and Bit-Robbed Signaling on One Link**



## RBS Data

The RBS data selection allows setting of the PCM robbed bit signaling data bit for a channel in one of the four links. When a bit pattern is selected, the least significant bit of every sixth frame is robbed and replaced with the appropriate bit in the pattern. (A frame refers to a T1 frame of 125 microseconds duration.) Since the pattern is four bits long, it repeats itself every 24 frames. The choices are 16 patterns from 0000 to 1111, which represent bit positions A, B, C, and D. The bits are robbed as follows:

- A = least significant bit of sixth frame.
- B = least significant bit of twelfth frame.
- C = least significant bit of eighteenth frame.
- D = least significant bit of twenty-fourth frame.

## PAL Module Control

**NOTE:** PAL Module Control of both positioning and signal level is superseded by EPAL commands, see the Programmer's Guide section of this manual for more information.

Control of the PAL module is accomplished by sending commands directly to the TAS Series II. The commands used to control the PAL Module are described in detail in the Programmer's Guide section of this manual.

## PAL Module Position

**NOTE:** PAL Module positioning is superseded by EPAL positioning.

The PAL module can be positioned in the signal path to appear either before satellite delay as the first impairment or after the white noise/impulse adder as the last impairment (Figure 2-23 and Figure 2-24).

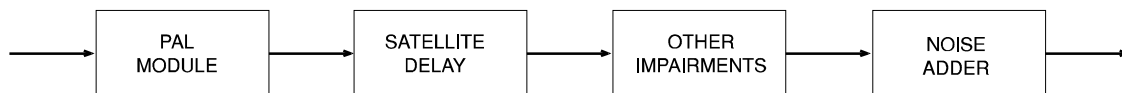

**Figure 2-23. PAL Module Before Satellite Delay**

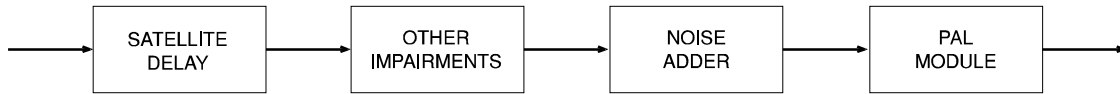

**Figure 2-24. PAL Module After Noise Adder**

In the first impairment position the PAL module is located just after the input level control circuit, but before the analog transmission impairment modules. This configuration simulates a transmission channel that consists of a cascade arrangement of a digital transmission facility that is followed by an analog transmission facility. In this position the nominal signal level that is input into the PAL is 0 dBm.

In the last impairment position the PAL module is located after all the analog transmission impairment modules behind the impulse and white noise adder. This configuration simulates a transmission channel that consists of a cascade arrangement of an analog transmission facility that is followed by a digital transmission facility. In this position the nominal signal level that input into the PAL depends on the programmed output level of the Series II. The signal to noise performance of the PAL is a function of signal level.

The PAL module simulates the quantization noise and signal distortion of digital transmission facilities that is caused by the effects of analog to PCM (64 kbps) signal conversion, as well as PCM to ADPCM conversion. Tables 2-16, 2-17 and 2-18 list typical signal to noise (S/N) ratios for 1 link to 4 links at 64 kbps, 40 kbps and 32 kbps respectively. The signal is a 1004 Hz tone and the noise is measured with a C-Notch weighting filter. The S/N data was measured at 4 output levels from 0.0 dBm to -40.0 dBm for mu-law coding with the PAL module positioned as the last impairment and all other transmission impairments disabled. The S/N performance with the PAL module positioned as the first impairment is represented by the data measured at an output signal (1004 Hz tone) of 0.0 dBm.

**NOTE:** If the EPAL module is present, the signal level seen by the digital links of the PAL will be defined by the input and output gain level set on the EPAL.

The PAL module is design to support a peak to RMS ratio that approaches 16 dB for a 0 dBm transmission signal.

<b>1004 Hz LEVEL (DBM)</b>	<b>1 LINK S/N (DB)</b>	<b>2 LINKS S/N (DB)</b>	<b>3 LINKS S/N (DB)</b>	<b>4 LINKS S/N (DB)</b>
0.0	41	38	37	35
-10.0	41	38	36	35
-20.0	39	35	34	33
-30.0	36	33	32	31
-40.0	29	27	25	24

**Table 2-17. Typical S/N Performance for 64 kbps (PCM) Links**

<b>1004 Hz LEVEL (DBM)</b>	<b>1 LINK S/N (DB)</b>	<b>2 LINKS S/N (DB)</b>	<b>3 LINKS S/N (DB)</b>	<b>4 LINKS S/N (DB)</b>
0.0	40	37	35	34
-10.0	39	36	34	33
-20.0	37	34	32	31
-30.0	34	31	29	28
-40.0	27	24	23	22

**Table 2-18. Typical S/N Performance for 40 kbps (ADPCM) Links**

<b>1004 Hz LEVEL (DBM)</b>	<b>1 LINK S/N (DB)</b>	<b>2 LINKS S/N (DB)</b>	<b>3 LINKS S/N (DB)</b>	<b>4 LINKS S/N (DB)</b>
0.0	36	33	31	29
-10.0	36	32	30	29
-20.0	34	31	29	28
-30.0	31	28	26	25
-40.0	26	23	21	20

**Table 2-19. Typical S/N Performance for 32 kbps (ADPCM) Links**

## **PAL Module Applications**

The PAL module can be used to characterize the performance of modems, fax machines or other types of data communications equipment or voice equipment against the types of impairments that are unique to digital transmission facilities. This type of characterization is very important because digital facilities are encountered on a very large percentage of Public Switched Telephone Network (PSTN) and private network connections. Examples of these facilities include T1 trunks or digital subscriber loop carrier systems.

The PAL module provides the capability to test error rate, throughput and other types of performance against the following transmission characteristics:

- Mu-law (domestic) and A-law (international) PCM quantization noise
- ADPCM bit compression distortion
- Random bit errors
- Robbed bit signaling distortion

<b>PARAMETER</b>	<b>DEFAULT VALUE</b>	<b>RANGE OF VALUES</b>
Link 1 PCM Coding	None	None, A-law or Mu-law
Link 2 PCM Coding	None	None, A-law or Mu-law
Link 3 PCM Coding	None	None, A-law or Mu-law
Link 4 PCM Coding	None	None, A-law or Mu-law
Link 1 PCM Rate	32 kbps	16, 24, 32, 40, or 64 kbps
Link 2 PCM Rate	32 kbps	16, 24, 32, 40, or 64 kbps
Link 3 PCM Rate	32 kbps	16, 24, 32, 40, or 64 kbps
Link 4 PCM Rate	32 kbps	16, 24, 32, 40, or 64 kbps
Errored Link	Link 1	Link 1, 2, 3, or 4
Error Rate	0	0, 2E-20, 2E-17, 2E-13, 2E-10, 2E-7, 2E-3
Robbed Bit Signaling Link	Link 1	Link 1, 2, 3, or 4
Robbed Bit Pattern	0000	0000 to 1111 (binary)
Robbed Bit Signaling Status	Disabled	Disabled or Enabled
PCM/ADPCM Module Position	After Noise Adder	After Adder or Before Delay

**TABLE 2-20. PCM/ADPCM Parameter Summary**

## 2.7. Digital Impairments (Extended PCM/ADPCM Option)

The system requirements are as follows:

- TASKIT for Windows Software: Version 1.20 or higher
- Series II Program Memory Cartridge: Version 2.10 or higher
- Extended PCM/ADPCM Module: Version 1.0 or higher

The TAS Series II optional Extended PCM/ADPCM Links (EPAL) module provides the means to test modem performance over various simulated digital transmission systems which are commonly found on intercontinental lines. With a EPAL module it is possible to perform the following functions:

- Simulate up to two tandem, digitally coded transmission links in each direction.
- Specify each link as mu-law or A-law, with 64 Kbps PCM, 32 Kbps ADPCM (custom), or 24 Kbps ADPCM (custom).
- Inject frame slip errors on the PCM bit stream of one of the two transmission links in each direction independently.

### 2.7.1. EPAL Module Features and Application

#### Link Selection

The EPAL module provides two independently controlled links in each direction. A link is defined as one digital coder/decoder pair in the signal path (Figure 2-25) which includes a digital-to-analog conversion followed by an analog-to-digital conversion. The coding always includes 8 bit PCM at a quantizer rate of 64 kbps. If the link has quantizer rates of 32 kbps or 24 kbps then the data is further coded to ADPCM.

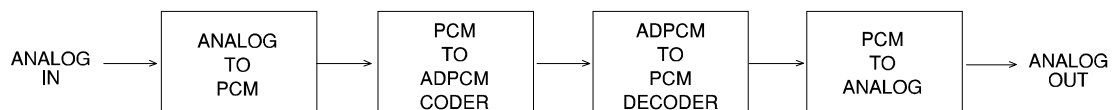

**Figure 2-25. Signal Path Through One Link**

## PCM Coding

The PCM coding feature allows choosing the algorithm used in analog to PCM coding. These algorithms optimize the dynamic range of the analog data sample. Coding can be independently set for each of the four links. The choices are none, mu-law, and A-law.

Both mu-law and A-law compress approximately 13 bits of dynamic range into 8 bits. Mu-law is the compounding characteristic adopted by the U.S. and Japan, while A-law is the compounding characteristic recommended by CCITT.

## Rate

The rate selection allows setting of the rate of serial data throughput on the simulated link. Note that as the required throughput decreases, the number of bits per sample correspondingly decreases. The rate can be independently set for each of the two links. The choices are:

- 64 kbps          8 bit PCM sampled at 8 kHz.
- 32 kbps          4 bit ADPCM sampled at 8 kHz.
- 24 kbps          3 bit ADPCM sampled at 8 kHz.

## Frame Slip Error Injection

A frame slip is a digital error where a sample of the signal is either repeated or skipped. Frame slips occur when a PCM coder on one end of a digital link is out of timing reference with the remainder of the network. The slight difference in clock speeds will result in an occasional frame slip.

Frame Slips are injected into the PCM bit streams of the EPAL Links as defined by the user. One of the two links may be errored in each direction simultaneously and independently. Frame slips may occur as often as .1 seconds or up to 3276.7 seconds with a regular or pseudo random interarrival time.

Frame slips may be only in one direction (either positive or negative) and thus are exhaustive due to the nature of the frame slip buffer. Frame slips may be cyclic and then in both directions so the buffer will never deplete. The buffer size (the number of frame slips in any one direction) is selectable by the user and ranges from 1 to 15. The user also has the ability to trigger frame slips independently of the frame slip switch.

For more information on the above features see the *Programmer's Guide* of this manual.

## EPAL Module Control

Control of the EPAL module is accomplished by sending commands directly to the TAS Series II. The commands used to control the EPAL Module are described in detail in the *Programmer's Guide* section of this manual.

## EPAL Module Position

The EPAL module can be positioned in the signal path to appear either before the analog channel (before satellite delay) as the first impairment or after the analog channel (after white noise/impulse adder) as the last impairment.

In the first impairment position the EPAL module is located just after the input level control circuit, but before the analog transmission impairment modules. This configuration simulates a transmission channel that consists of a cascade arrangement of a digital transmission facility that is followed by an analog transmission facility. In this position the nominal signal level that is input into the EPAL is 0 dBm.

In the last impairment position the EPAL module is located after all the analog transmission impairment modules behind the impulse and white noise adder. This configuration simulates a transmission channel that consists of a cascade arrangement of an analog transmission facility that is followed by a digital transmission facility. In this position the nominal signal level that input into the EPAL depends on the programmed analog channel output level of the Series II. The signal to noise performance of the EPAL is a function of signal level.

The EPAL has control of the signal level throughout the digital channel with both an input and output gain control level. The digital channel (including the PAL) may be tested at any signal level the gain factors will provide without forcing the analog channel to the same signal level.

The EPAL module simulates the quantization noise, signal distortion, and frame slips of digital transmission facilities that is caused by the effects of analog to PCM (64 kbps) signal conversion, as well as PCM to ADPCM conversion.

Within the digital channel there exist both the PAL digital links and the EPAL digital links. The relative position of these is a user programmable feature via the /EP,Pp/ command.

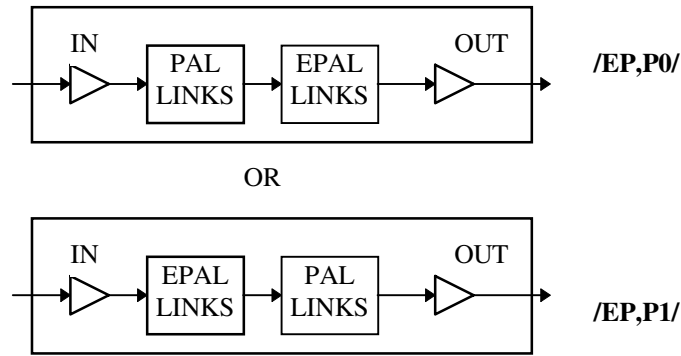

**Figure 2-26. Digital Channel Configuration**

### EPAL Module Applications

The EPAL module can be used to characterize the performance of modems, fax machines or other types of data communications equipment or voice equipment against the types of impairments that are unique to digital transmission facilities. This type of characterization is very important because digital facilities are encountered on a very large percentage of Public Switched Telephone Network (PSTN) and private network connections. Examples of these facilities include T1 trunks or digital subscriber loop carrier systems.

The EPAL module provides the capability to test error rate, throughput and other types of performance against the following transmission characteristics:

- Mu-law (domestic) and A-law (international) PCM quantization noise
- ADPCM (international) bit compression distortion
- Frame Slip errors

PARAMETER	DEFAULT VALUE	RANGE OF VALUES
ECI Link 1 PCM Coding	None	None, A-law or Mu-law
OKI Link 2 PCM Coding	None	None, A-law or Mu-law
ECI Link 1 PCM Rate	64 kbps	32 or 64 kbps
OKI Link 2 PCM Rate	64 kbps	24, 32 or 64 kbps
Frame Slip Error Link	ECI Link 1	Link 1 or 2
Frame Slip Interarrival Time	60 sec	1/10 to 32767/10 sec
Digital Channel Position	After Analog Channel	Before or After Analog
PAL Relative to EPAL	After EPAL Links	Before or After EPAL Links

**Table 2-21. EXTENDED PCM/ADPCM Parameter Summary**



## 2.8. Cellular Audio Processor (CAP) Module Option

The key features of the TAS Series II CAP include:

- Emulation of all cellular VF (Voice Frequency ) characteristics as defined by EIA/IS-19-B, and 20A as well as EIA/TIA-553, and EIA/TIA/IS-55 cellular standards.
- Selectable test topology (GT Cellular or Tandem)
- A→B (cellular to PSTN) channel for “GT Cellular” topology provides:
  - De-emphasis
  - Expansion
- B→A (PSTN to cellular) channel for “GT Cellular” topology provides:
  - Compression
  - Pre-emphasis
  - Limiter
  - Post-Limiter Filter
- A→B (cellular to PSTN) channel for “Tandem” topology provides:
  - Compression
  - Pre-emphasis
  - Limiter
  - Post-Limiter Filter
  - De-emphasis
  - Expansion
- B→A (cellular to PSTN) channel for “Tandem” topology provides:
  - Compression
  - Pre-emphasis
  - Limiter
  - Post-Limiter Filter
  - De-emphasis
  - Expansion

### 2.8.1. Test Topology

The TAS Series II CAP provides cellular audio processing functions for both the A→B (cellular to PSTN) and B→A (cellular to PSTN) channel. The specific functions that are available in each channel are dependent on the test topology that is selected. Figures 2-27 and 2-28 illustrate the available functionality for each topology along with the nominal signal levels that are associated with each configuration.

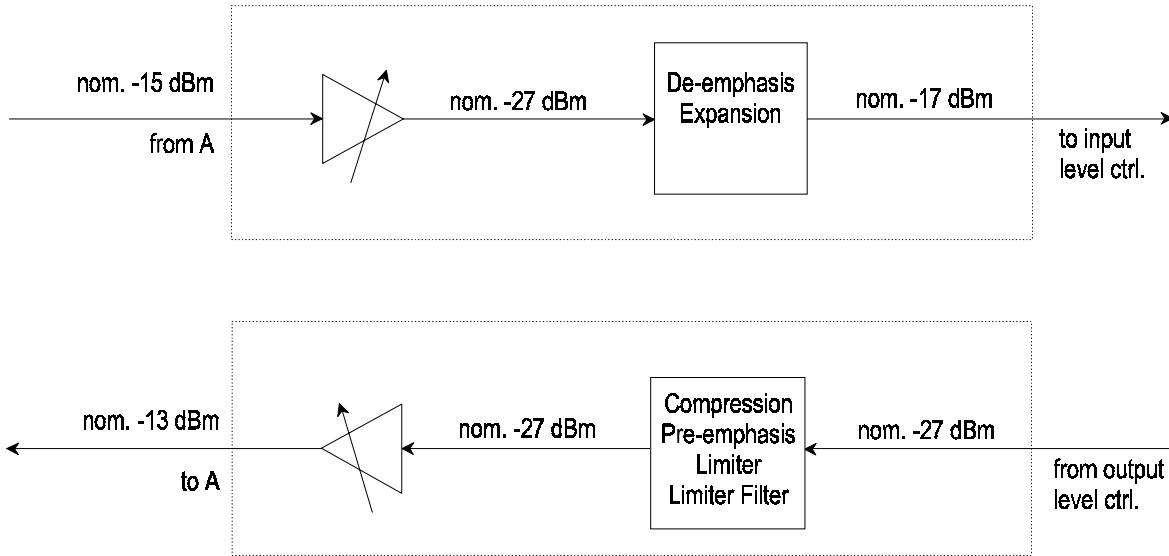

Figure 2-27. GT Cellular Topology

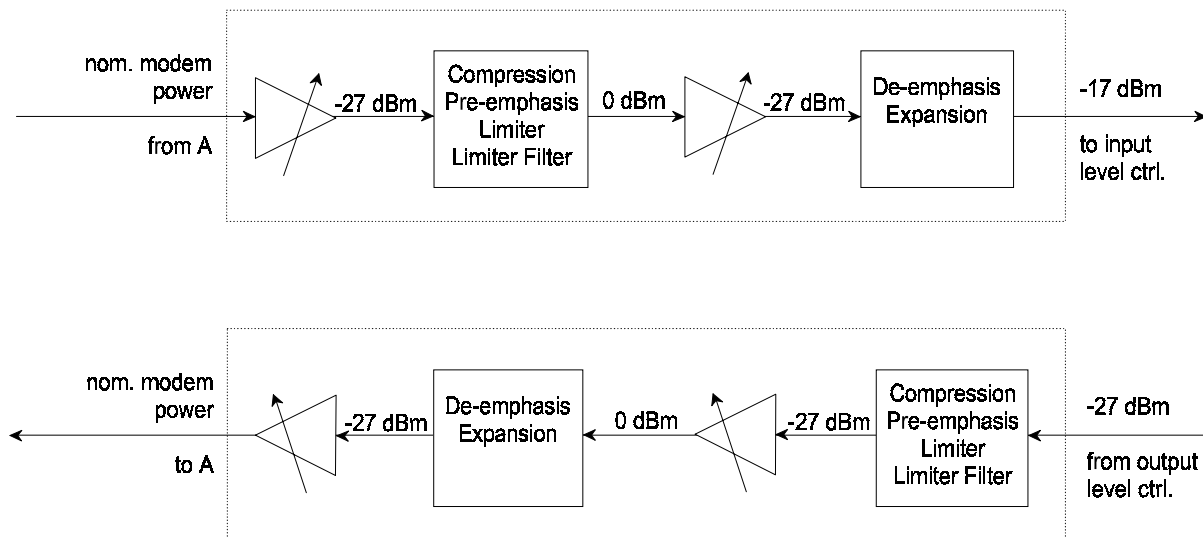

Figure 2-28. Tandem Topology

The GT Cellular Topology of the TAS Series II CAP permits the TAS Series II to interface with a base station emulator such as the TAS 6600. The TAS 6600 provides a nominal reference signal level of -15 dBm to the station A interface of the TAS Series II when the TAS 6600 receives a RF signal with 2.9 kHz of frequency deviation. Likewise the TAS 6600 will transmit an RF signal with 2.9 kHz of frequency deviation when its VF input port is presented with a nominal reference level of -13 dBm by the station A output of the TAS Series II.

### 2.8.2. TAS Series II CAP System Interface

The TAS Series II CAP is a plug-in hardware module that interfaces (internal to TAS Series II) with both the A→B and B→A channels of the TAS Series II Telephone Network Emulator. Figure 2-29 illustrates the interface between the Series II CAP and the system resources of the TAS Series II.

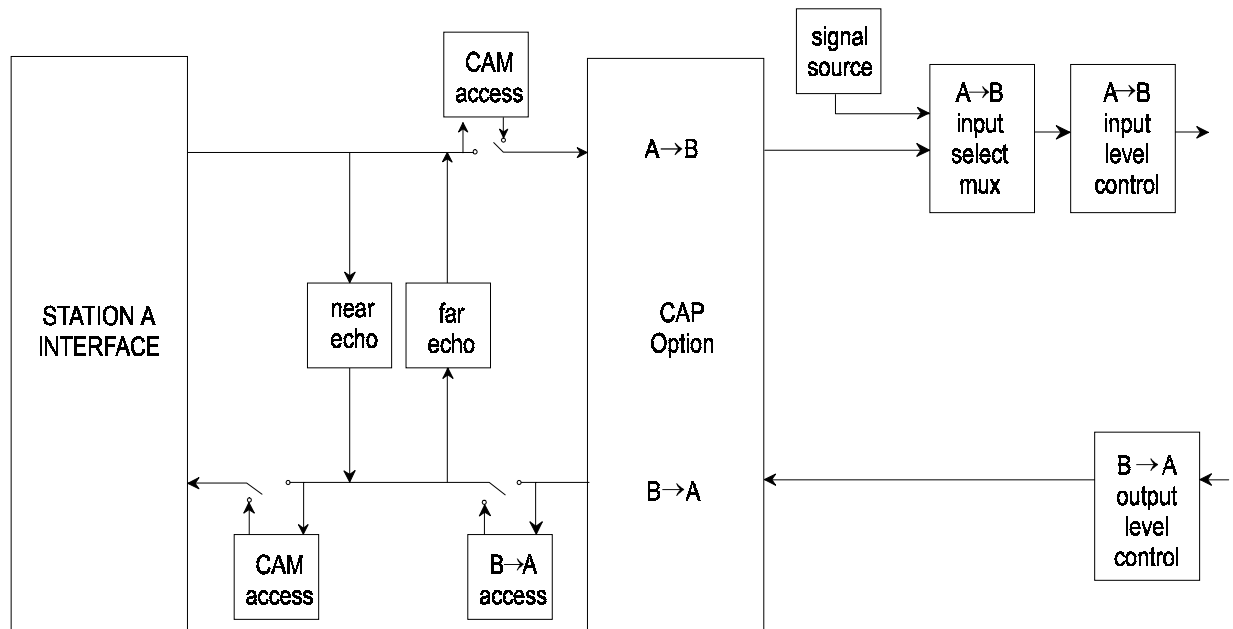

Figure 2-29. TAS Series II CAP System Interface

## 2.9. Echo/Satellite Delay

The Series II provides extensive echo simulation capability. This includes near talker echo, far talker echo, intermediate talker echo and listener echo.

An echo is an unwanted replica of the transmission signal that is caused by a signal reflection at one or more impedance discontinuities, and is delayed in time relative to the original signal.

The terms “near talker echo”, “far talker echo”, “intermediate echo”, and “listener echo” that are used to describe the most common types of echo, originate from voice communication application. This terminology specifies the relative location from where the echo originated, as well as the identity of the signal that comprises the echo. The location of the echo and its composition is relative to the party that hears (receives) the echo.

“Talker Echo” is a replica of the signal that a party speaks (talks) that is heard at the end of the network where the speaker is located. The speaker in a data communications application is the modem’s transmitter and the echo is heard by the modem’s receiver.

“Listener Echo” is a replica of the signal which a party hears (listens to) that is heard more than once by the listener. The listener in a data communications application is a modem’s receiver.

“Near Echo” is a special case of talker echo in which the modem’s transmit signal is reflected at a location near the modem’s receiver, and as a result, has little to no associated time delay.

“Far Echo” is a special case of talker echo in which the modem’s transmit signal is reflected at a location far from the modem’s receiver, and as a result has significant time delay.

“Intermediate Echo” is a special case of talker echo in which the modem’s transmit signal is reflected at a location within the telephone network, and as a result as a time delay between near echo and far echo.

The Series II supports the following echoes:

- Station A and Station B Near Talker Echo
- Station A and Station B Far Talker Echo
- Station A and Station B Intermediate Echo
- Station A and Station B Listener Echo

### 2.9.1. Near Talker Echo

The Series II provides near end talker echo simulation for station A and station B. Station A (B) near talker echo is illustrated in Figure 2-30 and is the reflection of the modem A (B) transmit signal that occurs at modem A (B). This reflection is caused by the impedance mismatch between the modem's hybrid balance impedance and the input impedance (Zmag) of the Series II station A (B) 2-wire interface.

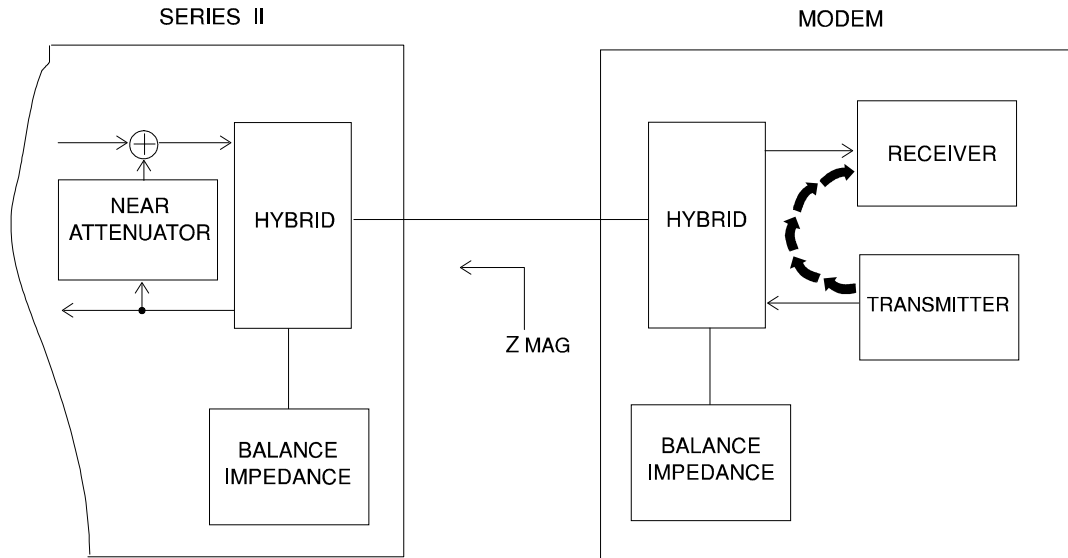

**Figure 2-30. Near Talker Echo without Loop**

The simulation is generated with the near A (B) echo attenuator and polarity control circuit. This capability allows the user to program the attenuation and polarity of the signal that is feedback from the transmit port to the receive port to the receive port of the Series II 2 to 4 wire hybrid. The net result of the signal feedback is that the input impedance of the Series II 2-wire interface is modified from its nominal magnitude of 600 ohms. The following table indicates the attenuation level and polarity setting for the near end echo parameters that generate a specific nominal magnitude of input impedance. The echo polarity should be set to non-inverting to create impedance values less than 600 ohms, and should be set to inverting for values greater than 600 ohms. The attenuation is calculated as follows:

$$\text{Attenuation} = -20 \log \left( \frac{\text{abs}((Z_{\text{mag}} - 600))}{(Z_{\text{mag}} + 600)} \right)$$

where:

abs = absolute value

Zmag = desired impedance magnitude

<b>INPUT IMPEDANCE MAGNITUDE</b>	<b>NEAR ECHO ATTENUATION</b>	<b>NEAR ECHO POLARITY</b>
300	9.5	Non-inverting
350	11.6	Non-inverting
400	14.0	Non-inverting
450	16.9	Non-inverting
500	20.8	Non-inverting
550	27.2	Non-inverting
600	40.0 or off	Non-inverting
650	28.0	Inverting
700	22.3	Inverting
750	19.1	Inverting
800	16.9	Inverting
850	15.3	Inverting
900	14.0	Inverting
950	12.9	Inverting
1000	12.0	Inverting
1050	11.3	Inverting
1100	10.6	Inverting
1150	10.1	Inverting
1200	9.5	Inverting
1250	9.1	Inverting
1300	8.7	Inverting
1350	8.3	Inverting
1400	8.0	Inverting
1450	7.7	Inverting
1500	7.4	Inverting

**Table 2-22. Input Impedance Simulation Summary**

The 2-wire line interface of a modem is connected its transmitter and receiver through a device called a hybrid. A hybrid is a four-port device used to separate signals traveling in both directions along a single pair of wires (2-wire) into individual directions (4-wire), and to recombine those signals traveling on 4-wire circuits for use at the 2-wire interface.

The modem's hybrid has a transmitter and a receiver connected to two of its four ports, the 2-wire network interface to the third port, and the balance network connected to the fourth port. If the impedance of the balance network is equal to the impedance at the 2-wire port over the frequency range of the signal, then the

transmit and receive ports are conjugate ports, that is, these ports are decoupled. The magnitude of decoupling is expressed as transhybrid loss. A ideal hybrid would have an infinite transhybrid loss.

The level of near talker echo that is experienced by a modem is equal to the modem's transmit level minus its transhybrid loss. The transhybrid loss is a function of the degree of mismatch between the modem's balance network impedance and the input impedance of the network.

PARAMETER	DEFAULT VALUE	RANGE OF VALUES
Station A Near Echo Attenuation	21.0 dB	-10.0 to 40.0 dB
Station B Near Echo Attenuation	21.0 dB	-10.0 to 40.0 dB
Station A Near Echo Polarity	non-inverting	non-inverting, inverting
Station B Near Echo Polarity	non-inverting	non-inverting, inverting
Status	Off	On/Off

**Table 2-23. Near Echo Parameter Summary**

<p><b>NOTE:</b></p> <ul style="list-style-type: none"> <li>• A negative value of attenuation produces signal gain instead of loss.</li> <li>• The polarity control causes the echo to be added to the modem's receive signal with no phase shift or with 180 degrees of phase shift.</li> <li>• A attenuator setting of 30 dB or more effectively disables the near echo simulation in 2-wire configurations.</li> </ul>
--

The impedance presented to the modem that is created with the Series II near echo attenuator and polarity control circuit is primarily resistive, and is constant with respect to frequency.

However, in practice, the input impedance of the actual telephone network is not just resistance, but also includes a reactive component, and is a function of frequency. This is due to the make-up of the loop plant. The loops vary because of cable gauge, length, loading, and termination. These loops present an impedance to the modem that is complex (resistive and reactive) and that changes as a function of frequency.

To test modem performance in a laboratory setting, especially the response of a modem to an echo condition, a testing arrangement is required whereby various mismatch conditions representative of those which occur in an actual field setting may be conveniently simulated. The TAS 240 Voiceband Subscriber Loop Emulator (VSLE) may be cascaded with the 2-wire port of the Series II to provide this capability. Loop emulation provides an alternative technique for generating

near talker echo in which the modem is presented with a complex (resistive and reactive) input impedance that is a function of frequency. This type of impedance is more representative of actual network conditions.

The 2-wire loop functions as a transmission line to connect the modem (unit under test) to the 2-wire port of the Central Office (Series II). The transmission line (loop) is terminated at one end by the input impedance of the Series II and at the other end by the input impedance of the modem. The impedance seen by the 2-wire port of the modem's hybrid is  $Z_{in}$  as shown in Figure 2-31.

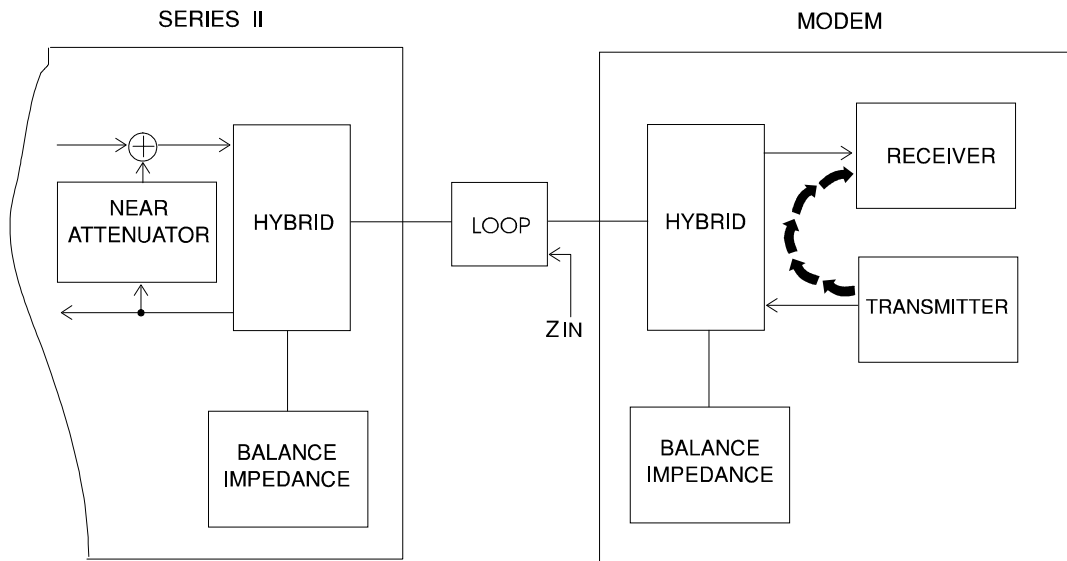

**Figure 2-31. Near Talker Echo With Loop**

Transmission line theory specifies that if a loop is terminated in an impedance that is not equal to its characteristic impedance, there will be a signal reflection at the point of this termination. In this application, the loop is terminated by the input impedance of the Series II. The input impedance magnitude of the Series II is approximately 600 ohms, which usually does not match the characteristic impedance of the loop. As a result, a reflection will occur at the termination mismatch created by the Series II input impedance.

- For applications that include the use of 2-wire loops to simulate near talker echo, there are several important facts that are worthy of note:
- The signal reflection that takes place because of the impedance mismatch at the loop termination changes the "effective input impedance" of the loop (as seen by the modem's 2-wire interface).
- The level of near talker echo that is experienced by a modem is equal to the modem's transmit level minus its transhybrid loss. The transhybrid loss



is determined by the impedance match between the modem's hybrid balance impedance and the "effective input impedance" of the loop.

- No near talker echo will be present at the receive side of the modem's hybrid if its hybrid balance impedance is equal to the "effective input impedance" of the loop.
- Near echo occurs at the modem's hybrid and the relatively small time delays associated with the echo is caused by the energy storage characteristics of the "effective input impedance" of the loop and the modem's hybrid balance impedance.

## 2.9.2. Far Talker Echo/Satellite Delay

The Series II provides far end talker echo simulation for station A and station B. Station B (A) far talker echo is illustrated in Figure 2-32 and is the reflection of the modem B (A) transmit signal that occurs at the station A (B) hybrid (far end) of the Series II. The magnitude of this reflection is determined by the transhybrid loss of the station A (B) hybrid. The station B (A) far echo attenuator magnitude is equal to the transhybrid loss of the Series II hybrid A (B), if the hybrid is balanced.

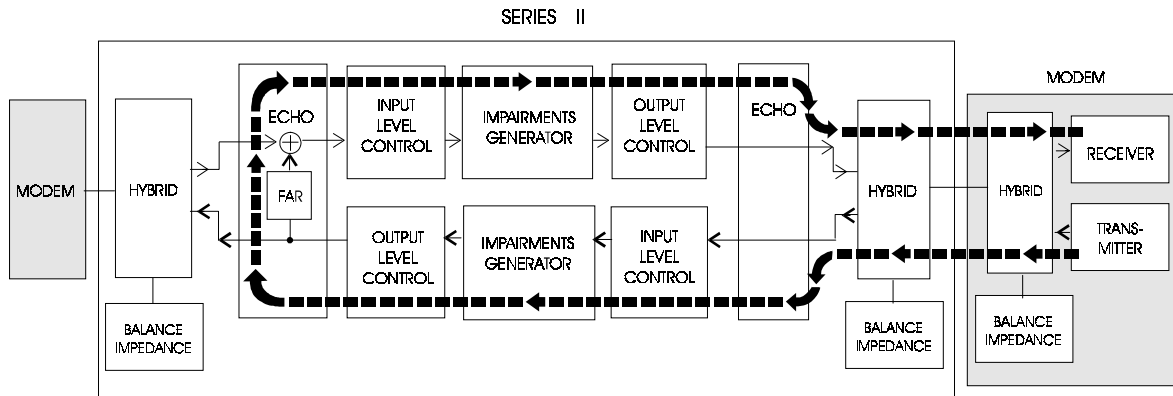

Figure 2-32. Far Talker Echo

The level of the far talker echo that is received at modem B (A) is determined by the loss in the A→B and B→A transmission channel along with the loss of the far echo attenuator B (A). Loss is the difference between the value of input level and output level.

The time delay (propagation delay) of far echo is determined by the transmission time delay in the A→B and B→A directions. Adjustable transmission time delay is available with the Series II by utilizing its satellite delay feature. However, note that satellite delay constitutes only part of the total propagation delay that a signal may encounter from station to station of a Series II transmission channel. Always adding to the overall propagation delay is the channel residual delay, together with the transmission time delay of each gain distortion and each group delay distortion filter selected as impairments. Transmission channel residual time delay for the Series II is 12.9 msec for test the EIA/CCITT test configuration, 15.8 msec for the ETSI-1 test configuration and 1.7 for the ETSI-2 test configuration. Each flat gain characteristic filter adds 0.0 msec of time delay, but other gain characteristic filters each add 2.12 msec of time delay if they are selected as impairments. In addition, while the flat group delay characteristic filters add 0.0 msec of time delay, each of the other group delay characteristic filters add unique transmission time delay as indicated in the technical specifications section of the manual. Total signal transmission time delay of a Series II impairment channel is determined as follows:

Total transmission delay

- = channel residual delay
- + gain distortion filter #1 transmission delay
- + group delay distortion filter #1 transmission delay
- + gain distortion filter #2 transmission delay
- + group delay distortion filter #2 transmission delay
- + programmed satellite delay time

This equation can also be written as follows to determine the magnitude of satellite delay that is required to achieve a specific value of total transmission delay:

Programmed satellite delay time

- = desired total transmission delay
- channel residual delay
- gain distortion filter #1 transmission delay
- group delay distortion filter #1 transmission delay
- gain distortion filter #2 transmission delay
- group delay distortion filter #2 transmission delay

For example, if two gain filters and one worst case CCITT M1025 characteristic delay filter are selected for the channel impairment path for the EIA/CCITT test configuration and a total delay in one direction of 100 msec is desired, then the satellite delay is calculated as follows:

Required satellite delay = 81.68 msec

$$= 100 \text{ msec} - 12.90 \text{ msec} - 2.12 \text{ msec} - 2.12 \text{ msec} - 1.18 \text{ msec}$$

PARAMETER	DEFAULT VALUE	RANGE OF VALUES
Delay	653.0 msec	0.0 to 1279.875 msec
Status	Off	On/Off

**Table 2-24. Satellite Delay Parameter Summary**

PARAMETER	DEFAULT VALUE	RANGE OF VALUES
Station A Far Echo Attenuation	21.0 dB	-10.0 to 40.0 dB
Station B Far Echo Attenuation	21.0 dB	-10.0 to 40.0 dB
Station A Far Echo Polarity	Non-inverting	Non-inverting, inverting
Station B Far Echo Polarity	Non-inverting	Non-inverting, inverting
Status	Off	On/Off

**Table 2-25. Far Talker Echo Parameter Summary**

The polarity control causes the echo to be added to the modem's receive signal with no phase shift or with 180 degrees of phase shift. It is provided for completeness, but unlike near echo it typically has no significant effect. The Series II allows the user to control the receive signal level to far talker echo level ratio. The value of far echo attenuation that is required to create the desired ratio can be determined from the following expressions.

Station A Far Echo Attenuation (positive or negative value in dB)

- = Desired receive signal to far echo ratio for modem A (positive value in dB)
- Series II B→A input level (negative value in dBm)
- + Series II A→B output level (negative value in dBm)

Station B Far Echo Attenuation (positive or negative value in dB)

- = Desired receive signal to far echo ratio for modem B (positive value in dB)
- Series II A→B input level (negative value in dBm)
- + Series II B→A output level (negative value in dBm)

These equations assume that the A→B input level of the Series II is set equal to the transmit signal level present at the station A modular telephone jack. In addition, the B→A input level of the Series II must be set equal to the transmit signal level present at the station B modular telephone jack. This means that if external loop simulation (TAS 240) is being used, the Series II input level should be set to modem's transmit level minus the loss produced by the loop. When loop

simulation is not used the Series II input level should be set to the modem's transmit level.

The following example will illustrate the far talker echo feature of the Series II.

Example User Test Conditions:

- Modem A and modem B transmit level = -9.0 dBm
- Desired 1004 trunk loss = 7.0 dB
- Loop loss = 0.0 dB (no external 2-wire loops)
- Gain distortion = flat
- Delay distortion = flat
- Desired receive signal to far end talker echo ratio at station B = 10.0 dB
- Desired receive signal to far end talker echo ratio at station A = 32.0 dB
- Desired round trip delay = 100.0 msec = A→B delay + B→A delay = 50 msec + 50 msec

Series II Parameter Values:

- Test configuration = EIA/CCITT
- A→B input level = -9.0 dBm = transmit level at station A interface
- A→B output level = -16.0 dBm = A→B input level - desired 1004 Hz loss
- B→A input level = -9.0 dBm = transmit level at station B interface
- B→A output level = -16.0 dBm = B→A input level - desired 1004 Hz loss
- Far A Echo Attenuation = 25.0 dBm = 32.0 dB - (- 9.0 dBm) + (- 16.0 dBm)
- Far B Echo Attenuation = 3.0 dBm = 10.0 dB - (- 9.0 dBm) + (- 16.0 dBm)
- A→B satellite delay = 50 msec - 12.9 msec = 37.1 msec
- B→A satellite delay = 50 msec - 12.9 msec = 37.1 msec

### 2.9.3. Intermediate Talker Echo

The Series II provides intermediate talker echo simulation for station A and station B as part of its auxiliary echo feature. This feature can be configured to simulate either intermediate talker echo or listener echo. Auxiliary echo is generated by the transmission channel impairments generator of the Series II. The TAS **Series II** provides bi-directional impairments simulation and can simultaneously support intermediate echo at both station A and station B.

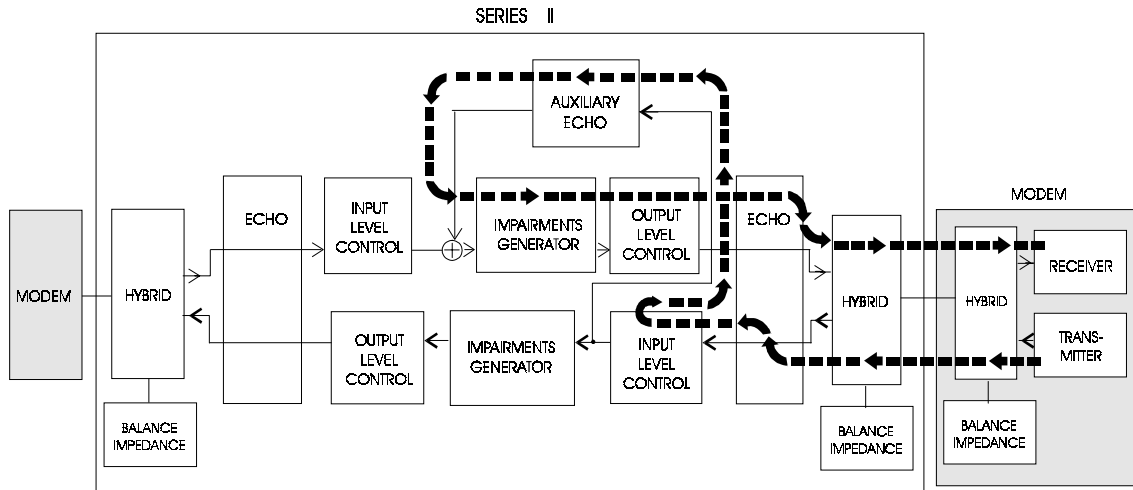

**Figure 2-33. Intermediate Talker Echo**

Station B (A) intermediate talker echo is illustrated in Figure 2-33 and is the reflection of modem B (A) transmit signal that occurs at a location intermediate to station A and station B. The level of this reflection is controlled by the auxiliary echo attenuation and its delay by the auxiliary echo delay.

PARAMETER	DEFAULT VALUE	RANGE OF VALUES
Station A (B→A) Intermediate Echo Attenuation	20.0 dB	0.0 to 40.0 dB
Station B (A→B) Intermediate Echo Attenuation	20.0 dB	0.0 to 40.0 dB
Station A (B→A) Intermediate Echo Delay	20.0 msec	0.0 to 875.0 msec (test configurations 0, 1) 0.0 to 290.0 msec (test configuration 2)
Status	Off	On/Off

**Table 2-26. Intermediate Echo Parameter Summary**

The programmed level of auxiliary echo attenuation directly controls the receive signal to intermediate talker echo ratio. This ratio is the relative level of echo to the receive signal level expressed in units of dB.

### 2.9.4. Listener Echo

The Series II provides listener echo simulation for station A and station B. Station B (A) listener echo is the reflection of the modem B (A) receive signal. The Series II provides two simulation techniques for listener echo. In the first technique illustrated in Figure 2-34, the level of echo is controlled by the combination of the station A far echo attenuation and the station B far echo attenuation. The time delay of listener echo is determined by the satellite delay in the A→B and B→A directions. In the second technique illustrated in Figure 2-35, the level of echo is controlled by the auxiliary echo attenuation and its delay by the auxiliary echo delay along with the B→A (A→B) satellite delay.

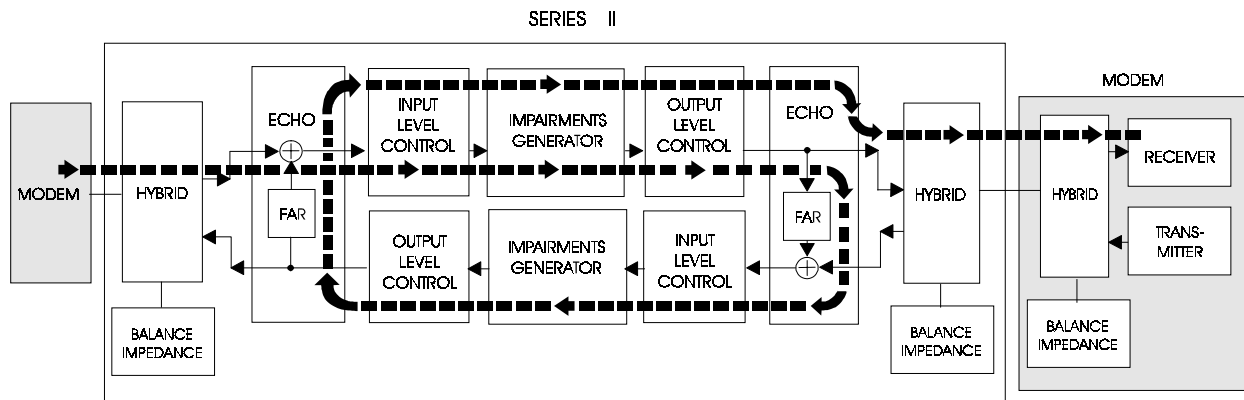

Figure 2-34. EIA/CCITT Listener Echo

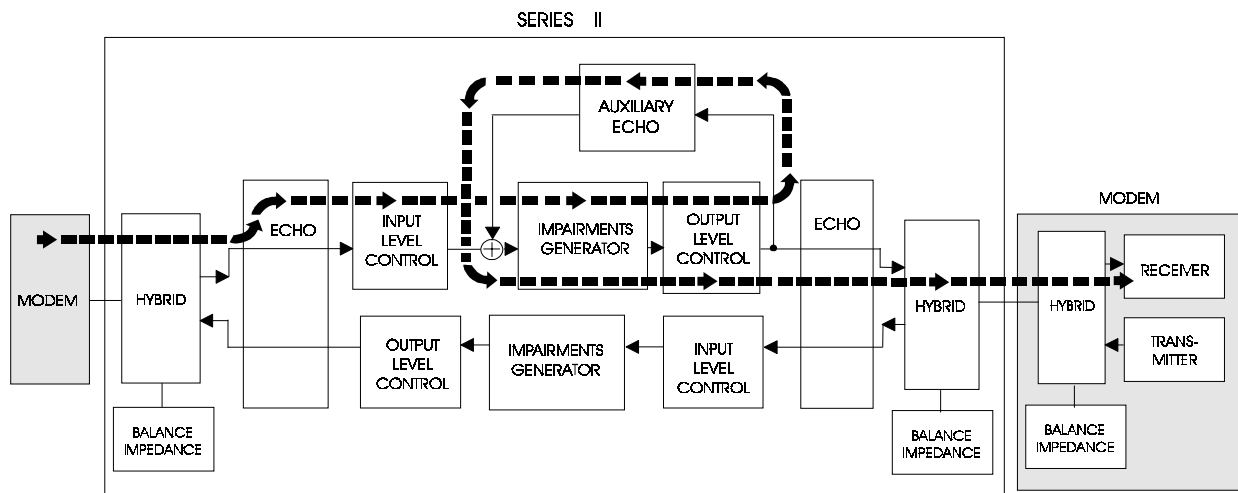

Figure 2-35. ETSI Listener Echo

The first technique is the method used in modem testing specifications issued by the Electronic (Telecommunications) Industries Association (EIA/TIA) and CCITT. The second method is specified by European Telecommunications Standards Institute (ETSI). The EIA method does not allow for listener echo simulation that is independent of far talker echo. The listener echo level is determined by the far talker echo level. As a result, the receive signal to listener echo ratio is dictated by the combination of the station A receive signal to far talker echo ratio plus the station B receive signal to far talker echo ratio, as expressed below:

Station A or B Receive Signal to Listener Echo Ratio (positive value in dB)

= Desired receive signal to far echo ratio for modem A (positive value in dB)

+ Desired receive signal to far echo ratio for modem B (positive value in dB)

The ETSI method is provided by the auxiliary echo feature of the Series II. This feature can be configured to simulate either intermediate talker echo or listener echo. Auxiliary echo is generated by the transmission channel impairments generator of the Series II. The TAS **Series II** provides bi-directional impairments simulation and can simultaneously support listener echo at both station A and station B.

PARAMETER	DEFAULT VALUE	RANGE OF VALUES
Station A (B→A) Listener Echo Attenuation	20.0 dB	0.0 to 40.0 dB
Station B (A→B) Listener Echo Attenuation	20.0 dB	0.0 to 40.0 dB
Station A (B→A) Listener Echo Delay	20.0 msec	0.0 to 875.0 msec (test configurations 0, 1) 0.0 to 290.0 msec (test configuration 2)
Status	Off	On/Off

**Table 2-27. Listener Echo Parameter Summary**



## 2.10. Measurement/Monitoring

The Series II includes an internal measuring device that provides the capability to measure the level and frequency of a transmission signal. In addition a programmable internal audio monitor is provided as well as selectable access points for external signal measurement and analysis.

### 2.10.1. Level & Frequency Measurement Module

The Signal Measurement Module provides the capability to perform an RMS level measurement in addition to a frequency measurement. The MM,R command will report the level of a signal over the range of +8.0 dBm to -56.0 dBm and its frequency over the range of 200 Hz to 3200 Hz. These measurements can be performed on any 1 of 6 user signals. The signals that are available for measurement include:

- Station A Transmit Signal (A0)
- Station B 4-Wire Receive Signal (B2)
- Station B 2-Wire Receive Signal (B1)
- Station B Transmit Signal (B0)
- Station A 4-Wire Receive Signal (A2)
- Station A 2-Wire Receive Signal (A1)

Figure 2-36 illustrates the locations where a measurement is performed for the 4-wire network configuration, and Figure 2-37 the location for 2-wire network configurations. Three of the measurement locations are in the A to B direction and three are in the B to A direction.

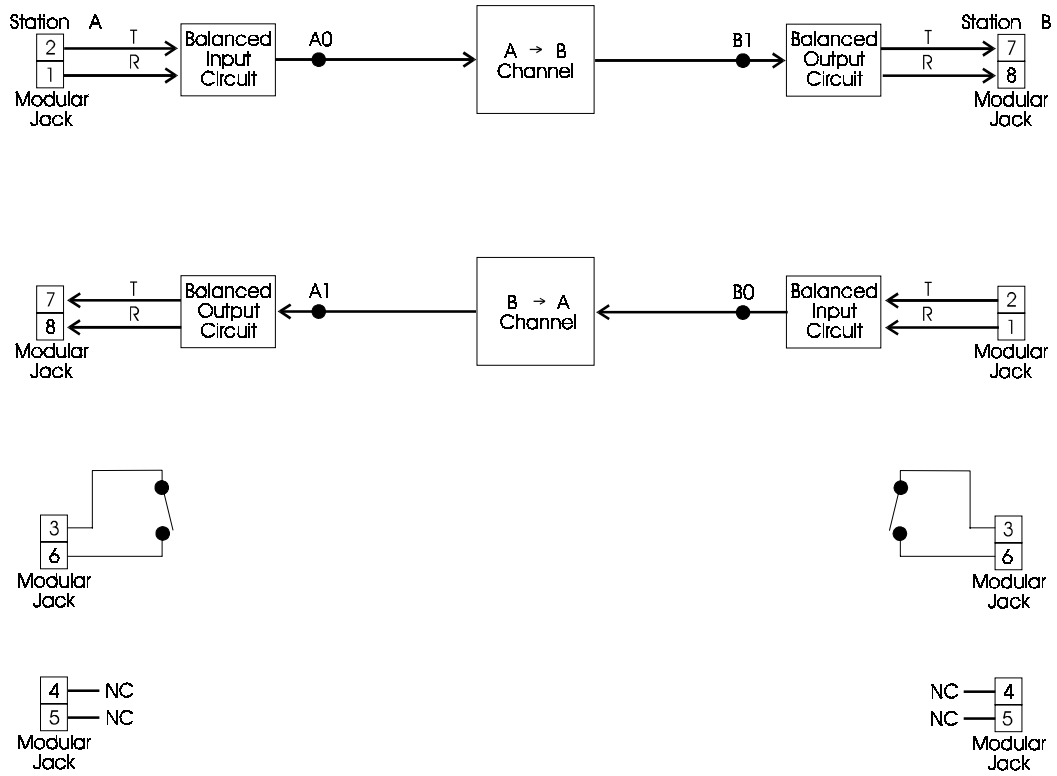
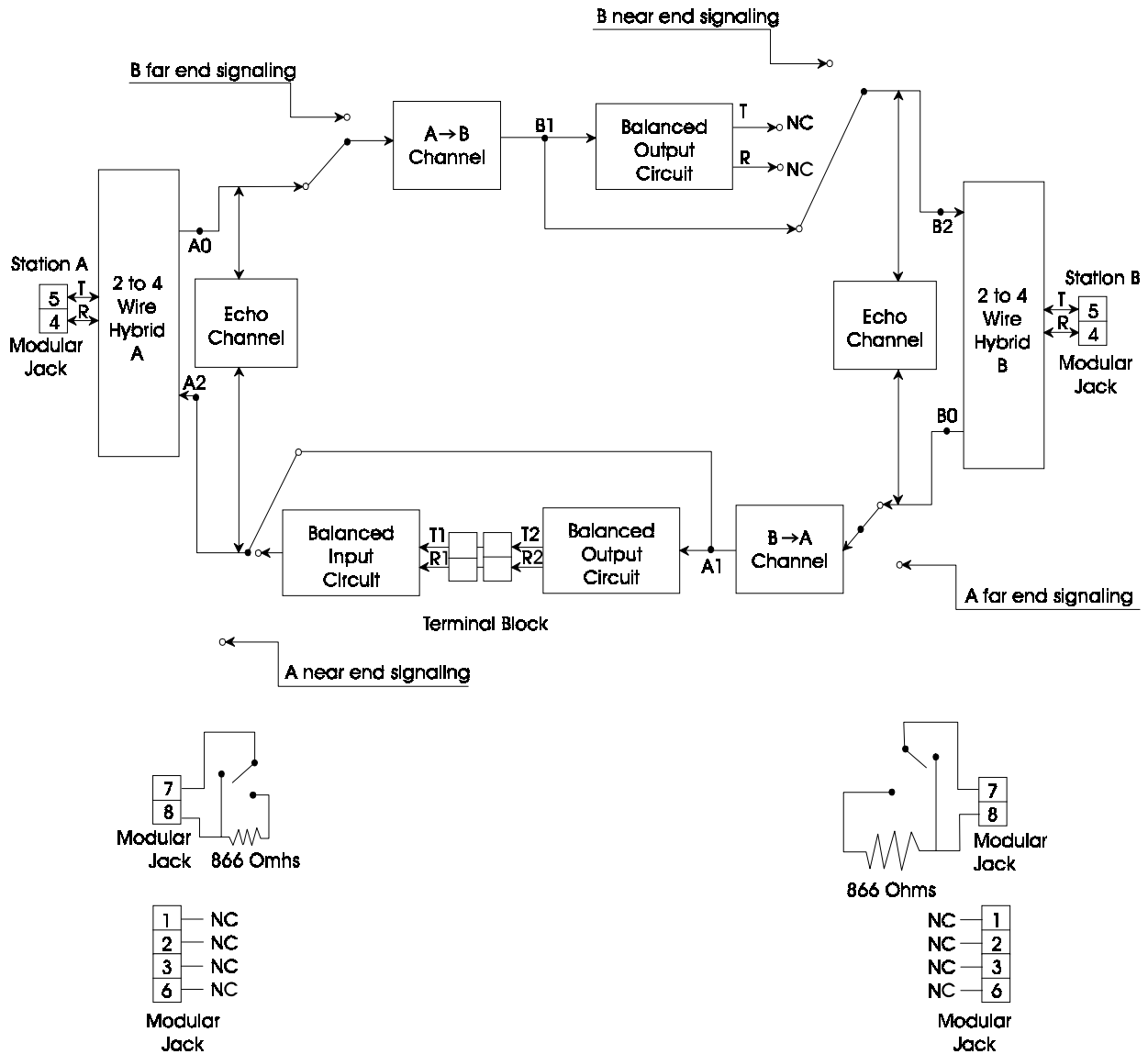

Figure 2-36. 4-Wire Configuration Measurement/Monitor Locations

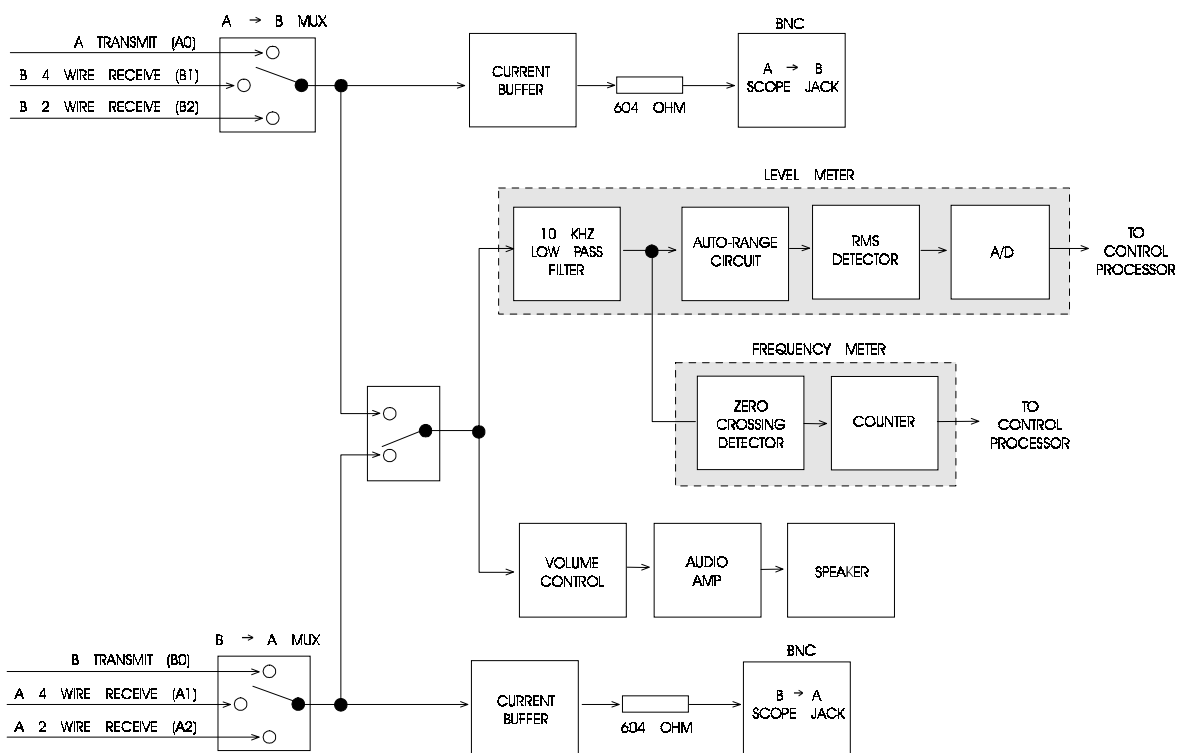

**Figure 2-37. 2-Wire Configuration Measurement/Monitor Locations**

The level and frequency measurement module reports the Root Mean Square (RMS) of the selected signal along with its frequency. The level measurement is capable of measuring the level of simple signals such as a sine wave or complex signals such as a high speed modem signal. The frequency measurement is designed to measure single frequency signals only, such as a sine wave, that have a level greater than -25 dBm.

A block diagram of the Series II frequency and level measurement module is shown in Figure 2-38. The major elements of this module consists of:

- Signal Multiplexer
- Low Pass Filter
- Auto Range Circuit
- RMS Detector
- A/D Converter
- Zero Crossing Detector/Counter



**Figure 2-38. Measurement and Monitor Circuit Block Diagram**

The signal multiplexer selects 1 out of 6 available signals for input to the measurement module. The output of the signal multiplexer is input to the low pass filter.

The low pass filter is a 2nd order butterworth filter with a 3 dB (cutoff) frequency at 10 kHz. This filter removes high frequency noise from the measurement signal. The output of the low pass filter is input to the auto range circuit.

The auto range circuit contains both programmable gain and attenuation. The primary function of the auto range circuit is to provide the optimum focus on the measurement signal to allow an accurate detection of its RMS level. The concept is somewhat analogous to adjusting the magnification on a microscope to achieve the optimum view of a small object. This circuit allows the measurement of signals over a large range of level from -56.0 dBm to +8.0 dBm.

The RMS detector circuit takes its input from the auto range circuit and generates a DC voltage that is equal to the RMS AC signal level. This DC output signal is input to the A/D converter.

The primary function of the A/D is to convert the analog DC voltage output of the RMS detector circuit into a digital word to be read by the Control Processor.

A zero crossing detector circuit and counter are used to measure the frequency of a single frequency transmission signal. The signal that drives the zero crossing detector is taken from the output of the measurement circuit's lowpass filter. A counter then records the number of zero crossings to determine the frequency of the signal.

### **2.10.2. Measurement Algorithm**

The level measurement technique is based upon the following operations:

- Measurement signal selection
- Measurement signal level translation (auto range)
- RMS detection
- Data acquisition

The signal level reported by the Series II is an arithmetic average that is determined by calculating the sum of 10 RMS level measurements and dividing the sum by 10.

Frequency is measured by the Series II using a simple counter technique. This involves the following basic steps:

1. Clear counter.
2. Wait for one second.
3. Read counter.

Counting the zero crossing of the signal for a period of one second yields a count value equal to the frequency in Hertz.

### 2.10.3. Monitoring

The Series II provides an audible output for the transmission signals in either the A to B or B to A direction. Scope ports and impulse noise synchronization ports are also provided to support the external monitoring of signals.

PARAMETER	DEFAULT	RANGE	COMMAND
A→B Monitor Signal	Station A Transmit	Station A Transmit, Station B Receive 4-Wire, Station B Receive 2-Wire	IO,E
B→A Monitor Signal	Station B Transmit	Station B Transmit, Station A Receive 4-Wire, Station A Receive 2-Wire	IO,F
Audio Monitor Direction	A→B	A→B, B→A	IO,D
Audio Monitor Volume	0 (off)	0 (off) to 15 (high)	IO,V

**Table 2-28. Monitor Parameters Summary Table**

#### Audio

The signal that is input to the audio monitor is selected from the "SCOPE A→B" monitor multiplexer or the "SCOPE A→B" monitor multiplexer as illustrated in Figure 2-38. The level of this signal is scaled to provide volume control before it is amplified and connected to a speaker that is mounted inside of the front panel.

The signal selection multiplexers for the audio monitor are also shared with the level measurement circuit. This may cause the audio monitor signal to be momentarily interrupted during a Series II level measurement. However the transmission channel is not affected.

#### Scope Ports

The Series II has two rear panel BNC connectors that provide external monitoring on signals in both directions of transmission. The monitor signals are selected by the monitor multiplexers illustrated in Figure 2-38. The A to B monitor signal is available at the rear panel jack labeled "SCOPE A→B" and the B to A monitor signal is available at the "SCOPE B→A" jack. The scope jacks are buffered and driven by a 604 ohm source impedance. The external device that is connected to these ports should provide a 604 ohm termination. The monitor signal will appear

at the scope jacks 6 dB above its actual level if a high impedance termination is provided instead of the 604 ohms.

The signal selection multiplexers for the scope jacks are also shared with the level measurement circuit. This may cause the scope monitor signal to be momentarily interrupted during a Series II level measurement. However the transmission channel is not affected.

### **Impulse Noise Synchronization Ports**

A pair of impulse noise synchronization jacks are provided on the rear panel of the Series II. The jacks are designated as "SYNC OUTPUT 1" and "SYNC OUTPUT 2". These jacks are located at the right side of the rear panel. The jack labeled "SYNC OUTPUT 1" is dedicated to the A to B transmission channel, and "SYNC OUTPUT 2" is dedicated to the B to A transmission channel. A falling edge TTL pulse is output at the jack of the activated impulse noise generator. This pulse goes low just before the start of any impulse and then returns to a high logic state just before the completion of the impulse. The feature can be used to synchronize other instruments (e.g., storage scope) to the impulses.

## 2.11. Basic Central Office Emulation

The Series II emulates the characteristics of the voiceband telephone network. The telephone network consists of transmission facilities and switching facilities. The transmission equipment is interconnected with switching equipment to create communication channels. This switching equipment and other types of interface equipment is located in a telephone company building referred to as a Central Office. The characteristics of this type of Central Office equipment is emulated by the Central Office emulation module of the Series II.

**NOTE:** See the Series II UCO User's Manual for information on Universal Central Office features.

The Central Office features are organized into four functional groups consisting of:

- Exchange Configuration Features
- Loop Signaling Features
- Call Progress Tones and Switching Features
- Dialing Analysis Features.

Exchange configuration features include the emulation of different types of traffic networks such as Private Line Data Networks and Public Switched Telephone Networks (PSTN). In addition, a variety of other configuration features such as interface isolation, loopback mode indication, hybrid balance selection, B to A channel access, programmable data jack, make busy and switched network status are provided.

Flexible loop signaling features include both a constant current source and voltage source for loop current generation. The ringing generator also provides many features such as programmable level, frequency, DC bias and polarity. In addition call progress tones and ringing can be manually sent to either station.

Comprehensive emulation of programmable call progress tones and automatic switching features allow the emulation of international signaling conditions. The dialing analysis features allow the DTMF (touch-tone) and dial pulse functions of a switched network DCE to be tested.

The unique exchange configuration features provided by the Series II are discussed in the following sections.



### 2.11.1. Network Traffic Configurations

The transmission and switching facilities of the telephone network are configured to carry specific types of communications traffic. The types of traffic networks supported by the Series II include:

- 4-Wire Private Network
- 2-Wire Switched Network
- 2-Wire Auto Switched Network
- 2-Wire Private Network

#### 4-Wire Private Network Configuration

Figure 2-39 shows a TAS Series II 4-wire private network configuration. This configuration supports two 4-wire, 600 ohm stations referred to as station A and station B. The two stations are connected on a continuous basis by a dedicated transmission channel in each direction. When using the TAS Series II, a 4-wire configuration provides full impairments simulation in both transmission directions.

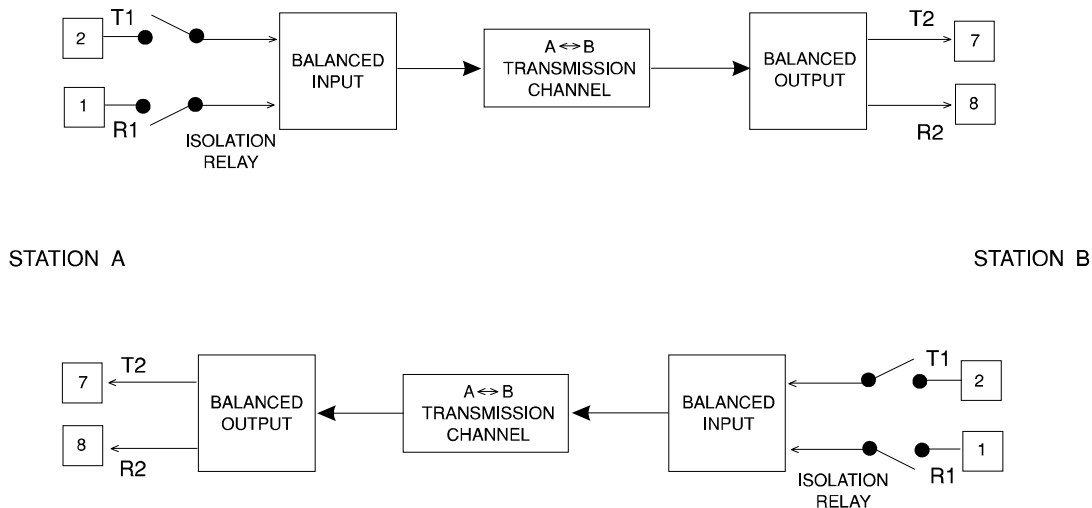
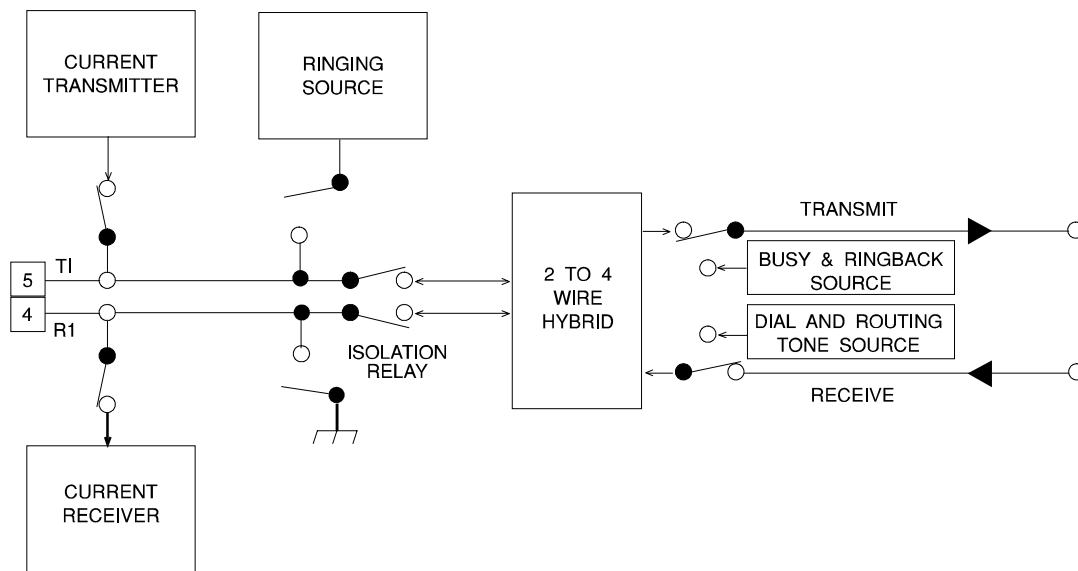

Figure 2-39. 4-Wire Private Network Configuration

## 2-Wire Switched Configuration

Figure 2-40 illustrates a Series II station interface for 2-wire switched network configuration. The 4-wire portion of this circuit provides the impairments simulation in both directions. A 2 to 4 wire interface circuit (hybrid) sits at either end of the 4-wire circuit. The 2-wire side of each hybrid is available for connection to a 2-wire station. A transmission from station A to station B passes through the impairments generator dedicated to the A→B direction, and a transmission from station B to station A passes through the impairments generator dedicated to the B→A direction.



**Figure 2-40. 2-Wire Switched Network Configuration Station Interface**

The Series II provides for 2-wire switched network emulation with a programmable current source/sink or a voltage source selected by the user. The 2-wire switched network emulation also provides audible ringing (ringback), busy, routing tones, and dial tone sources at the 4-wire side of each hybrid. Each of these sources is programmable. For each 2-wire station, the dial tone and routing sources originate at the near end of the circuit, and the ringback and busy sources originate at the far end of the circuit. This configuration accurately simulates real switched networks.

The switched network emulation automatically detects DTMF (touch-tone) or dial pulse signaling from each 2-wire station, and automatically performs loop-start signaling to process calls. Calls may be placed in either direction (A→B or B→A). Processing of a typical call from station A→B (B→A) proceeds as follows:

1. Station set A (B) goes off-hook.
2. The central office emulator provides dial tone to station A (B).
3. Station A (B) begins dialing using DTMF or pulse signaling.
4. The central office emulator receives the dialed digits. When the quantity of digits dialed is equal to the quantity of digits for the station B (A) telephone number, the central office emulator compares the dialed number to the station B (A) number. If the number is correct and station B (A) is on-hook, the central office emulator provides a path between the two stations, rings station B (A), and provides audible ringing to station A (B). If the number is correct, but station B (A) is off-hook, the central office emulator does not ring station B (A). Instead, station A (B) receives a busy signal until station A (B) goes back on-hook. If the number is not correct, the central office emulator does not provide a path between the stations, and does not ring station B (A). In this event, station A (B) receives a busy signal until it goes back on-hook.
5. If the number was dialed correctly, station B (A) detects ringing and goes off-hook.
6. The central office emulator stops ringing station B (A), and stops providing audible ringing to station A (B).
7. Stations A and B can now communicate between each other via the transmission channels in the TAS Series II. The central office emulator continues to provide the connection until either station goes on-hook.

## **2-Wire Auto Switched Configuration**

The 2-wire auto switched configuration is similar to the 2-wire switched configuration except that all signaling functions are disabled. The loop current is active and is used to establish a connection through the emulator. When either station goes off hook, loop current flows but no call establishment functions (dial tone, etc.) are enabled. When the second station goes off hook, loop current is detected and a connection is established between station A and B. When either station goes back on hook, the connection between stations is broken.

## 2-Wire Private Line Configuration

A 2-wire private network configuration is similar to the 2-wire switched configuration, except that all switching, signaling and loop current functions are disabled. This configuration provides two 2-wire stations with a hybrid at either end of the transmission path. The two stations are connected on a continuous basis by a dedicated transmission channel in each direction. When using a TAS Series II, full impairments simulation is provided in both transmission directions.

PARAMETER	DEFAULT	RANGE	COMMAND
Network Configuration Mode	4-wire Private	4-wire private, 2-wire switched, 2-wire private 2-wire autoswitched	LC, M

**Table 2-29. Network Configuration Mode Parameter Summary**

### 2.11.2. Interface Isolation

This feature is functional for all 2-wire and 4-wire network traffic configurations. In 2-wire configurations this feature allows the transmission signal on terminals 5 (tip) and 4 (ring) from the station set (telephone or DCE) to be isolated from the Series II AC interface circuitry as shown in Figure 2-45. Terminals 5 and 4 will be open circuited from the 2 to 4-wire hybrid of the Series II when the interface isolation is in its active state. However DC loop current and ringing remain available to the telephone or DCE device during isolation.

In the 4-wire configuration this feature allows the transmission signal on terminals 2 (tip) and 1 (ring) from the station set (telephone or DCE) transmitter to be isolated from the Series II AC interface circuitry as shown in Figure 2-44. Terminals 2 and 1 will be open circuited from the 4-wire input circuit of the Series II when the interface isolation is in its active state. However the station set's receiver will not be isolated and will remain connected to 4-wire output circuit on pins 7 and 8 of the Series II station interface.

PARAMETER	DEFAULT	RANGE	COMMAND
Station A Interface Isolation	Isolation Inactive	Active, Inactive	LC, IA
Station B Interface Isolation	Isolation Inactive	Active, Inactive	LC, IB

**Table 2-30. Interface Isolation Parameter Summary**

The interface isolation feature is used in applications where it is necessary to isolate the DCE or telephone from the load presented by the input impedance of the Series II.

### 2.11.3. 4-Wire Configuration Features

The vast majority of exchange configuration features, loop signaling features, call processing features and dialing analysis features are not applicable to the 4-wire private network traffic configuration. The primary exception is the loopback mode indicator feature.

#### Loopback Mode Indicator (MI)

This feature is available in the 4-wire private configuration only. Relay contacts are provided to control electrical continuity between terminals 3 and 6 on the 8 contact station set interface. An open circuit between these pins indicates that the loopback mode is active and that the line is not available for transmission. This simulates a loopback of a leased line toward the central office or an out-of-service condition. A short circuit between pins 3 and 6 indicates that the loopback mode is inactive. This relay is specified in the EIA TR30.3 Telecommunications Systems Bulletin No. 18.

PARAMETER	DEFAULT	RANGE	COMMAND
Station A Mode Indicator	Loopback Inactive	Active, Inactive	LC, XA
Station B Mode Indicator	Loopback Inactive	Active, Inactive	LC, XB

**Table 2-31. Loopback Mode Indicator (MI) Parameter Summary**

The status (active or inactive) of the mode indicator can not be changed while the Series II is setup in any of the 2-wire configurations. An open circuit will be present between terminals 3 and 6 for the 2-wire configurations. Control information for the mode indicator will be accepted and saved while the unit is in 2-wire mode but will not be executed until the 4-wire configuration is selected.

### 2.11.4. 2-Wire Configuration Features

The Series II supports some unique features for its 2-wire network configurations. The external hybrid balance feature, B to A channel access feature and programmable data jack feature are available for all 2-wire configurations. However, the make busy feature and switched network status feature are applicable to 2-wire switched operation only.

#### Hybrid Balance

This feature is functional for all 2-wire network traffic configurations. In 2-wire configurations this feature allows the user to select between a Series II internally supplied 604 ohm resistor or an external user supplied balance impedance. The external impedance for the hybrid at Station A must be connected between the terminals labeled "A1" and "A2" on the Series II rear panel "Balance Networks" terminal block. Likewise, the external impedance for the hybrid at Station B must be connected between the terminals labeled "B1" and "B2" on the Series II rear panel "Balance Networks" terminal block.

PARAMETER	DEFAULT	RANGE	COMMAND
Station A Hybrid Balance	Internal	Internal, External	LC, BA
Station B Hybrid Balance	Internal	Internal, External	LC, BB

**Table 2-32. Hybrid Balance Parameter Summary**

The 2-wire station interfaces of the Series II are connected to the four wire transmission channels through devices called hybrids. A hybrid is a four-port device used to separate signals traveling in both directions along a single pair of wires (2-wire) into individual directions (4-wire), and to recombine those signals traveling on 4-wire circuits for use at the 2-wire interface.

The Series II hybrids have a transmit transmission channel and a receive transmission channel connected to two of its four ports, the 2-wire station interface to the third port, and the balance network connected to the fourth port. If the impedance of the balance network is equal to the impedance at the 2-wire port over the frequency range of the signal, then the transmit and receive ports are conjugate ports, that is, these ports are de-coupled. The magnitude of de-coupling is expressed as transhybrid loss. A ideal hybrid would have an infinite transhybrid loss.

An external balance impedance is used in applications where the internal 604 ohm balance impedance does not provide an adequate impedance match (transhybrid loss).

### B to A Channel Access

This feature is functional for all 2-wire network traffic configurations. In 2-wire configurations this feature allows the user to insert an external device in series with the B to A transmission channel of the Series II. When this feature is enabled the B to A transmission channel is open circuited just after the internal channel as illustrated in Figure 2-41. Access to both sides of this open circuit is then provided by the rear panel terminal block labeled "External B→A".

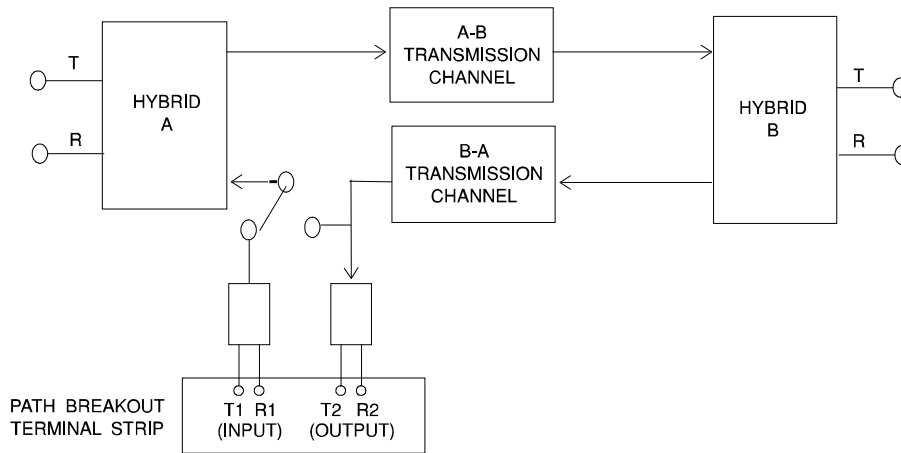

**Figure 2-41. B to A Channel Access Interface**

Terminals T1/R1 form a balanced (differential) input interface that presents a 600 ohm termination. Terminals T2/R2 form a balanced (differential) output interface with a 600 ohm source impedance. Terminals T2/R2 would connect to the input of an external device and terminals T1/R1 would connect to the output of an external device.

PARAMETER	DEFAULT	RANGE	COMMAND
B to A Channel Access	Disabled	Disabled, Enabled	LC, E

**Table 2-33. B to A Channel Access Parameter Summary**

This feature is typically used in situations where it is desired to provide transmission channel simulation other than that supplied by the internal B to A channel of the Series II. In such a situation the B to A channel access is enabled and an externally supplied channel simulator inserted.



### Program Resistor (Programmable Data Jack)

This feature is available in all 2-wire configurations only. It provides a programmable data jack arrangement for DCEs that are capable of operating in program mode. An 866 ohm resistor or an open circuit may be applied between terminals 7 and 8 of the eight terminal station set interface of the Series II. The presence of the 866 ohm resistor signals the DCE to transmit at a level of -4 dBm.

This data jack arrangement is specified in the EIA-496-A standard.

PARAMETER	DEFAULT	RANGE	COMMAND
Station A Program Resistor	open circuit	open circuit, 866 ohms	LC, YA
Station B Program Resistor	open circuit	open circuit, 866 ohms	LC, YB

**Table 2-34. Program Resistor Parameter Summary**

The status (open circuit or 866 ohms) of the program resistor can not be changed while the Series II is setup in the 4-wire configurations. Terminals 7 and 8 are used to supply the receive signal (emulator output) for the 4-wire configuration. Control information for the program resistor will be accepted and saved while the unit is in 4-wire configuration but will not be executed until a 2-wire configuration is selected.

### Make Busy

This feature is functional for the 2-wire switched network configuration only. In 2-wire switched configuration this feature forces the originating station to encounter a busy condition by making the answer station appear busy. When "make busy" is enable at the answer station the originating station will receive a busy tone at the completion of the dialing sequence independent of the availability of the answer station.

PARAMETER	DEFAULT	RANGE	COMMAND
Make Busy	Disabled Station B	Enabled/Disabled, Station A/Station B	SG, M

**Table 2-35. Make Busy Parameter Summary**

This feature can be used to test the response of a station set device such as a DCE, when a busy tone is encountered during call setup.

## **Switched Network Status**

The Series II is capable of reporting the status of either the Station A or Station B interface. This includes hook status, connect status, dialing status, signaling tone and ringing status. The SG, ZA command reports the status of Station A and SG, ZB reports the status of Station B. Hook status reports if the station set device is on-hook or off-hook. Connect status indicates if the two stations are currently connected (call established). Dialing status specifies if the Series II is expecting DTMF (touch-tone) or dial pulse information from the originating station while the dialing sequence is in process. In addition the status of primary dial tone, busy tone, ringback and high voltage ringing is provided.

### **2.11.5. Loop Signaling Features**

The loop signaling features of the Series II include a programmable loop current generator and ringing generator.

#### **Loop Current Generator**

A DC loop current generator is provided by the Series II to support Loop Start signaling. Loop Start signaling is a form of supervisory signaling that uses DC current to indicate the desire to originate a call or to indicate answer at the called station. The Series II uses this type of signaling to detect hook status (on-hook or off-hook).

During its on-hook state a telephone or DCE prevents DC current flow between tip and ring by creating an open circuit (high impedance). When it goes off-hook it creates a low DC impedance to allow DC current to flow. The 2-wire switched and 2-wire auto-switched configurations of the Series II interpret the presence of DC current flow between tip (pin 5) and ring (pin 4) as an off-hook condition. The absence of DC current flow is interpreted as an on-hook condition.

See Table 2-33 for a summary of all loop current generator parameters and their associated commands.

#### **Loop Current Generator Battery Voltage**

The Series II has a dedicated power supply for the loop current generator. This supply provides battery voltage for two different types of loop current sources; a constant current source and a voltage source. The battery voltage can be programmed to have a 45V or 54V output.

## Constant Current Source

The loop current generator can be selected to be a constant current source or a voltage source. The constant current source is independently controlled at each station interface and is designed to generate a programmed level (10 mA to 126 mA) of loop current. As illustrated in Figure 2-42, this is accomplished with a constant current transmitter and a constant current receiver. The DC loop current originates from the transmitter, flows through the loop and the telephone or DCE into the current receiver. The loop current level is constant and independent of the magnitude of loop resistance (total resistance between tip and ring). This independence is maintained until the voltage across tip and ring exceeds the compliance voltage of the current source. See the technical specifications section of the manual for more information on the characteristics of the constant current source.

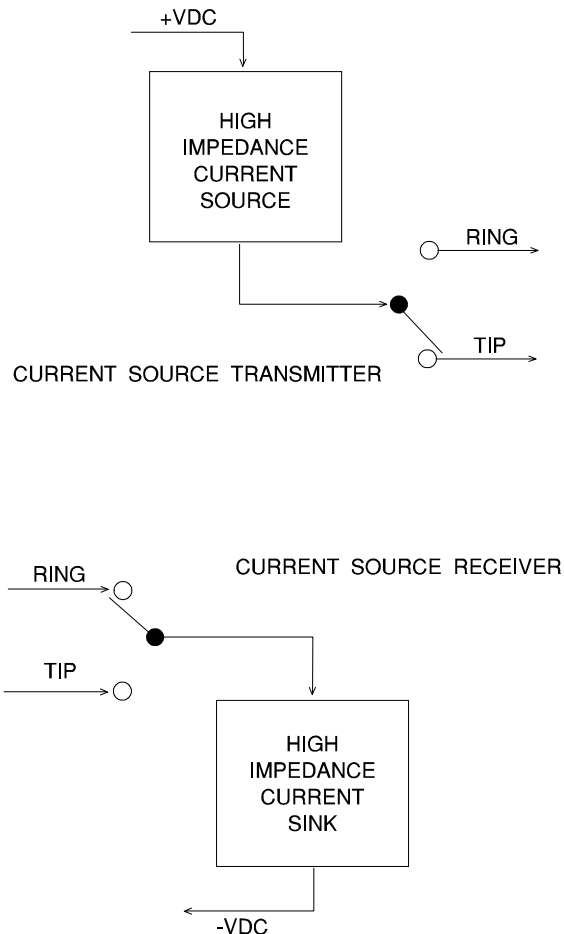

**Figure 2-42. Current Source Transmitter and Receiver**

## Voltage Source and Feed (Loop) Resistance

The loop current generator can be selected to be a constant current source or a voltage source. The voltage source is designed to produce loop current by feeding the battery voltage through a feed resistance and electronic inductor into the load across tip and ring as illustrated in Figure 2-43. Unlike the constant current source, the level of loop current depends on the selected battery voltage (45 or 54 V), the selected feed resistance (300 or 1400 ohms), resistance of the telephone or DCE and the characteristics of the electronic inductor. The DC loop current originates from the transmitter, flows through the loop and the telephone or DCE into the current receiver. See the technical specifications section of the manual for more information on the characteristics of the voltage source.

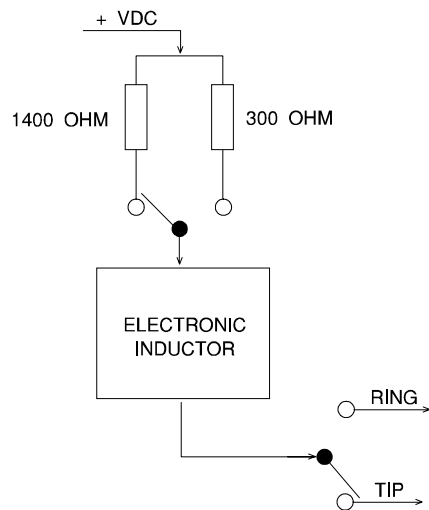

VOLTAGE MODE LOOP CURRENT TRANSMITTER

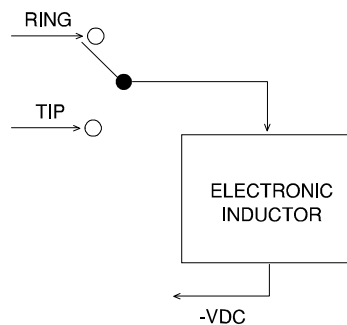

VOLTAGE MODE LOOP CURRENT RECEIVER

**Figure 2-43. Voltage Source Transmitter and Receiver**

## Loop Current Polarity

The loop current generator of the Series II can supply current with a positive or negative polarity. Positive polarity means that loop current flows from tip to ring. Negative means that current flows from ring to tip.

PARAMETER	DEFAULT	RANGE	COMMAND
Battery Voltage	45 V	45V, 54V	LC, V
Generator Type Source	current voltage source	current source	LC, S
Station A Current Source Level	18 mA	10 to 126 mA	SG, JA
Station B Current Source Level	18 mA	10 to 126 mA	SG, JB
Station A Voltage Source Feed Resistance	1400 ohms (high)	300 (low) 1400 (high)	LC, LA
Station B Voltage Source Feed Resistance	1400 ohms (high)	300 (low) 1400 (high)	LC, LB
Station A Loop Current Polarity	positive	positive, negative	SG, KA
Station B Loop Current Polarity	positive	positive, negative	SG, KB

**Table 2-36. Loop Current Generator Parameter Summary**

For applications that use external 2 wire loop simulation, caution should be exercised when configuring the loop current generator. The potentially large DC impedance of the loops may create DC voltage requirements that exceed the capability of the Series II. This problem can usually be avoided by selecting the voltage source with a 54 V battery and 300 ohm (low) feed resistance, or current source with 54 V battery at 24 mA.

The loop current generator power supply (battery) is configured to float relative to earth (frame) ground. This means the DC voltage that is formed across tip (pin 5) and ring (pin 4) by the loop current is not referenced to earth ground.

## Ringling Generator

The Series II provides an user programmable ringling generator to support emulation of the Public Switched Telephone Network (PSTN). This generator is used to alert the answer station of an incoming call.

Ringling is a high voltage low frequency AC signal that is superimposed on a DC bias voltage (battery). It is comprised of a single frequency (typically 20 or 25 Hz) sine wave that is offset (biased) on a DC voltage (typically between 45 to 54 Volts). The AC level, DC bias voltage, frequency and cadence of ringling can be controlled, where the cadence is the same as that specified for ringback. In addition, ringling can be generated with a positive polarity or negative polarity. Positive polarity ringling creates a positive DC bias potential from tip (positive) relative to ring (negative). The ringling generator applies the positive potential of the bias voltage to the tip conductor and the AC ringling signal with a negative bias potential to the ring conductor.

Negative polarity ringling creates a negative DC bias potential from tip (negative) relative to ring (positive). The ringling generator applies the positive potential of the bias voltage to the ring conductor and the AC ringling signal with a negative bias potential to the tip conductor.

The cadence (on/off times) of ringling will be identical to that of ringback. Ringback will be generated to the originating station whenever ringling is being generated to the answer station.

PARAMETER	DEFAULT	RANGE	COMMAND
Frequency	20.0 Hz	15.0 to 75.0 Hz	SG, Y
Level	85 Vrms	1 to 100 Vrms	SG, A
DC Bias Voltage (45 or 54V)	Vbattery	(12V, Vbattery/2, Vbattery/2 + 12V, or Vbattery)	SG, Q
Polarity	positive	positive, negative	SG, W

**Table 2-37. Ringling Generator Parameter Summary**

The Series II ringling generator is designed to support a telephone or DCE device that represents a load of one Ringer Equivalence Number (REN). This type of load presents an AC impedance of approximately 7000 ohms at the ringling frequency and a high DC impedance.

The Series II sends ringing to the called station by automatically performing the following operations:

- Activates interface isolation to open circuit tip (pin 5) and ring (pin 4) from the 2-wire to 4-wire hybrid circuit.
- Disconnects the programmable loop current generator.
- Connects the positive potential of the bias voltage to the tip conductor for positive ringing polarity, or to the ring conductor for negative ringing.
- Connects the AC ringing signal with a negative bias potential to the ring conductor for positive ringing polarity, or to the tip conductor for negative ringing.

In 2-wire switched configuration the Series II will automatically disconnect ringing (trip ringing) when it detects 10 mA or more of DC current flow from the bias voltage source. The telephone or DCE generates a path for DC current flow when it makes an on-hook (high DC impedance) to off-hook (low DC impedance) transition to answer the call.

The Series II performs ring trip at the called station by automatically performing the following operations:

- Disconnects ringing generator from tip (pin 5) and ring (pin 4).
- Deactivates interface isolation to connect tip (pin 5) and ring (pin 4) to the 2-wire to 4-wire hybrid circuit. Interface isolation will not be deactivated if the station interface has been explicitly configured for isolation (see Interface Isolation section of manual).
- Connects the programmable loop current generator.

## Forced Signaling

The Series II allows the user to manually send (force) signaling to either station A or station B. Activation of this feature disables all the automatic signaling features of the 2-wire switched configuration independent of hook-status. The selected signaling is forced to the indicated station until a different signal is selected or the feature is disabled. In 2-wire configurations ringing/ringback, primary dial tone, or busy may be forced to either station. In 4-wire configuration ringing/ringback, or busy may be forced to either station. Only one forced signaling selection will be active at a given time.

PARAMETER	DEFAULT	RANGE	COMMAND
Send Signaling	disabled	send ringing to A and ringback to B send ringing to B and ringback to A send primary dial tone to A send primary dial tone to B send busy to A send busy to B disabled	SG, S

**Table 2-38. Forced Signaling Parameter Summary**

Caution should be exercised when using this feature to force ringing. The automatic ring trip function of the Series II is disabled when ringing is forced. This means that the high voltage ringing signal will continue to be applied to tip (pin 5) and ring (pin 4) after the telephone or DCE has gone off-hook (answered). Ringing will continue ("ringing in the ear") until a different type of signaling is forced or manual signaling is disabled.



## 2.11.6. Call Progress Tones and Switching Features

The Series II provides flexible call progress and switching features that can support virtually all U.S. and international signaling formats.

### Primary Dial Tone

Primary (First) dial tone is provided by the Series II when the unit is configured for 2 wire switched operation. It is an audible tone that is supplied to the station interface following an off hook transition. The tone provides an indication to the telephone set or DCE that has dialing priority (see Dial Priority section below) that the Series II is ready to receive dial signals (dial pulses or DTMF).

Primary dial tone is a signal comprised of two single frequency sine waves. The frequency of each sine wave can be controlled. In addition the level and cadence (on/off times) of the composite waveform can be specified. This waveform originates from the near end Central Office of the Series II and does not traverse the impairments channel. As a result the dial tone signal is not subjected to the simulated transmission impairments.

PARAMETER	DEFAULT	RANGE	COMMAND
Frequency 1	350.0 Hz	100.0 to 3400.0 Hz	SG, C0, FA
Frequency 2	440.0 Hz	100.0 to 3400.0 Hz	SG, C0, FB
Level	-10 dBm	0 to -50 dBm	SG, D
On Time 1	0 msec	0 to 60000 msec	SG, C1, RA
Off Time 1	0 msec	0 to 60000 msec	SG, C1, RD
On Time 2	0 msec	0 to 60000 msec	SG, C1, RB
Off Time 2	0 msec	0 to 60000 msec	SG, C1, RE
On Time 3	200 msec	0 to 60000 msec	SG, C1, RC
Off Time 3	0 msec	0 to 60000 msec	SG, C1, RF

**Table 2-39. Primary Dial Tone Parameter Summary**

A single frequency primary dial tone can be generated by specifying frequency 1 and frequency 2 to be the same. In this case the two sine waves are summed together in phase to produce a single frequency tone with a level that is 3 dB higher than the programmed value. Dial tone level is calibrated for a dual tone signal that consists of tones of unequal frequency. Two tones of unequal frequency produce a signal that is 3 dB lower than that generated by two tones of identical frequency and phase.

A continuous tone will be generated whenever all off times of the cadence are zero and there is a non-zero on time (on time 3). A single stage cadence (one non-

zero on time and one non-zero off time) should be specified using on time 3 and off time 3. A two stage cadence (two non-zero on times and two non-zero off times) should be specified using on time 2 and off time 2 for the first stage along with on time 3 and off time 3 for the second stage. A three stage cadence (three non-zero on times and three non-zero off times) should be specified using on time 1 and off time 1 for the first stage, along with on time 2 and off time 2 for the second stage and on time 3 and off time 3 for the third stage.

## Secondary Dial Tone

Secondary dial tone is provided by the Series II when the unit is configured for 2 wire switched operation. It is an audible tone that is generated to the station interface of the originating device when the dialing sequence reaches a predetermined intermediate point of the specified telephone number. The tone provides an indication to the originating telephone set or DCE, that the portion of the telephone number that has been dialed matches that specified for the answer station, and that it may resume with sending dial signals (dial pulses or DTMF) for the next segment of the telephone number.

Secondary dial tone is a signal comprised of two single frequency sine waves. The frequency of each sine wave can be controlled. In addition the level and cadence (on/off times) of the composite waveform can be specified, where the level is the same as that specified for primary dial tone. This waveform originates from the near end Central Office of the Series II and does not transverse the impairments channel. As a result the secondary dial tone signal is not subjected to the simulated transmission impairments.

PARAMETER	DEFAULT	RANGE	COMMAND
Frequency 1	350.0 Hz	100.0 to 3400.0 Hz	SG, C2, FA
Frequency 2	440.0 Hz	100.0 to 3400.0 Hz	SG, C2, FB
Level	-10 dBm	0 to -50 dBm	SG, D
On Time 1	0 msec	0 to 60000 msec	SG, C2, RA
Off Time 1	0 msec	0 to 60000 msec	SG, C2, RD
On Time 2	0 msec	0 to 60000 msec	SG, C2, RB
Off Time 2	0 msec	0 to 60000 msec	SG, C2, RE
On Time 3	2000 msec	0 to 60000 msec	SG, C2, RC
Off Time 3	0 msec	0 to 60000 msec	SG, C2, RF

**Table 2-40. Secondary Dial Tone Parameter Summary**

Secondary dial tone is used in the call setup sequence by specifying a telephone number that includes a "+" (plus sign) at the point where the secondary dial tone is desired. The following example illustrates the use of the plus sign to generate a

secondary dial tone. In this example Station A is the originate station and the telephone number of Station B (answer station) is 555+987.

### **Secondary Dial Tone Example:**

Station A goes off hook and receives the first dial tone after dial tone delay expires.

Station A dials 555 (first dial tone is turned off when 1st digit is dialed).

Station A receives secondary dial tone after network routing delay expires.

Station A dials 987.

Station B receives ringing and Station A receives ringback (audible ringing) after network routing delay expires.

A single frequency secondary dial tone can be generated by specifying frequency 1 and frequency 2 to be the same. In this case the two sine waves are summed together in phase to produce a single frequency tone with a level that is 3 dB higher than the programmed value. Dial tone level is calibrated for a dual tone signal that consists of tones of unequal frequency. Two tones of unequal frequency produce a signal that is 3 dB lower than that generated by two tones of identical frequency and phase.

A continuous tone will be generated whenever all off times of the cadence are zero and there is a non-zero on time (on time 3). A single stage cadence (one non-zero on time and one non-zero off time) should be specified using on time 3 and off time 3. A two stage cadence (two non-zero on times and two non-zero off times) should be specified using on time 2 and off time 2 for the first stage along with on time 3 and off time 3 for the second stage. A three stage cadence (three non-zero on times and three non-zero off times) should be specified using on time 1 and off time 1 for the first stage, along with on time 2 and off time 2 for the second stage and on time 3 and off time 3 for the third stage.

## Busy Tone

Busy tone is provided by the Series II when the unit is configured for 2 wire switched operation. It is an audible tone that is supplied to the station interface of the originating device when the desired answer station is unavailable. The tone provides an indication to the originating telephone set or DCE that the desired answer station is busy (unavailable) because it is currently off hook, a "make busy" condition is active (see Make Busy description in Exchange Configuration section) or the dialed telephone number does not match that specified for the desired answer station (wrong number).

Busy tone is a signal comprised of two single frequency sine waves. The frequency of each sine wave can be controlled. In addition the level and cadence (on/off times) of the composite waveform can be specified, where the level is the same as that specified for transmission channel output. The busy signal originates from the far end Central Office of the Series II at a level of 0 dBm and then transverses the impairments channel. As a result the busy signal is subjected to the simulated transmission impairments that are present in the transmission direction that terminates at the originating station.

PARAMETER	DEFAULT	RANGE	COMMAND
Frequency 1	480.0 Hz	100.0 to 3400.0 Hz	SG, FC
Frequency 2	620.0 Hz	100.0 to 3400.0 Hz	SG, FD
Station A Level	-13.0 dBm	0.0 to -50.0 dBm	IO, T
Station B Level	-18.0 dBm	0.0 to -50.0 dBm	IO, L
On Time 1	500 msec	0 to 60000 msec	SG, BA
Off Time 1	500 msec	0 to 60000 msec	SG, BB

**Table 2-41. Busy Tone Parameter Summary**

Busy tone is encountered by the originating station when the answer station is not available. The following example illustrates a situation in which Station A (originating station) would receive a busy tone. In this example the telephone number of Station B (answer station) is 5559876 and the output level of the B to A transmission channel is -23.5 dBm.

**Busy Tone Example:**

Station A goes off hook and receives the first dial tone after dial tone delay expires.

Station A dials 5449877 (wrong number).

Station A receives busy signal at -23.5 dBm after network routing delay expires.

A single frequency busy tone can be generated by specifying frequency 1 and frequency 2 to be the same. In this case the two sine waves are summed together in phase to produce a single frequency tone with a level that is 3 dB higher than the programmed value. Busy tone level is calibrated for a dual tone signal that consists of tones of unequal frequency. Two tones of unequal frequency produce a signal that is 3 dB lower than that generated by two tones of identical frequency and phase.

A continuous tone will be generated whenever the off time of the cadence is zero and the on time is non-zero.

## Ringback (Audible Ringing)

Ringback is provided by the Series II when the unit is configured for 2 wire switched operation. It is an audible tone that is supplied to the station interface at the completion of a dialing sequence. The tone provides an indication to the originating telephone set or DCE that the call has been routed to the addressed station (answer station) and that an alerting signal (ringing) is being applied to the answer station.

Ringback tone is a signal comprised of two single frequency sine waves. The frequency of each sine wave can be controlled. In addition the level and cadence (on/off times) of the composite waveform can be specified, where the level is the same as that specified for transmission channel output. The ringback signal originates from the far end Central Office of the Series II at a level of 0 dBm and then transverses the impairments channel. As a result the ringback signal is subjected to the simulated transmission impairments that are present in the transmission direction that terminates at the originating station.

PARAMETER	DEFAULT	RANGE	COMMAND
Frequency 1	440.0 Hz	100.0 to 3400.0 Hz	SG, FE
Frequency 2	480.0 Hz	100.0 to 3400.0 Hz	SG, FF
Station A Level	-13.0 dBm	0.0 to -50.0 dBm	IO, T
Station B Level	-18.0 dBm	0.0 to -50.0 dBm	IO, L
On Time 1	0 msec	0 to 60000 msec	SG, C0, RA
Off Time 1	0 msec	0 to 60000 msec	SG, C0, RD
On Time 2	0 msec	0 to 60000 msec	SG, C0, RB
Off Time 2	0 msec	0 to 60000 msec	SG, C0, RE
On Time 3	2000 msec	0 to 60000 msec	SG, C0, RC
Off Time 3	4000 msec	0 to 60000 msec	SG, C0, RF

**Table 2-42. Ringback Parameter Summary**

A single frequency ringback signal can be generated by specifying frequency 1 and frequency 2 to be the same. In this case the two sine waves are summed together in phase to produce a single frequency ringback with a level that is 3 dB higher than the programmed value. Ringback level is calibrated for a dual tone signal that consists of tones of unequal frequency. Two tones of unequal frequency produce a signal that is 3 dB lower than that generated by two tones of identical frequency and phase.

The cadence of ringing (alerting) will be identical to that of ringback. Ringing will be generated to the answer station whenever ringback is present at the originate station. A continuous ringback and ringing will be generated whenever all off

times of the cadence are zero and there is a non-zero on time (on time 3). A single stage cadence (one non-zero on time and one non-zero off time) should be specified using on time 3 and off time 3. A two stage cadence (two non-zero on times and two non-zero off times) should be specified using on time 2 and off time 2 for the first stage along with on time 3 and off time 3 for the second stage. A three stage cadence (three non-zero on times and three non-zero off times) should be specified using on time 1 and off time 1 for the first stage, along with on time 2 and off time 2 for the second stage and on time 3 and off time 3 for the third stage.

### Routing Tone (Call in Progress Tone)

Routing tone is provided by the Series II when the unit is configured for 2 wire switched operation. It is an audible tone that is supplied to the station interface of the originating device once the dial signals (dial pulses or DTMF) for a dialing segment has been received. The tone provides an indication to the originating telephone set or DCE that the network is in the process of routing the connections to complete the call.

Routing tone is a signal comprised of two single frequency sine waves. The frequency of each sine wave can be controlled. In addition the level and cadence (on/off times) of the composite waveform can be specified, where the level is the same as that specified for primary dial tone. This waveform originates from the near end Central Office of the Series II and does not transverse the impairments channel. As a result the routing tone is not subjected to the simulated transmission impairments.

PARAMETER	DEFAULT	RANGE	COMMAND
Frequency 1	440.0 Hz	100.0 to 3400.0 Hz	SG, C3, FA
Frequency 2	440.0 Hz	100.0 to 3400.0 Hz	SG, C3, FB
Level	-10 dBm	0 to -50 dBm	SG, D
On Time 1	0 msec	0 to 60000 msec	SG, C3, RA
Off Time 1	0 msec	0 to 60000 msec	SG, C3, RD
On Time 2	0 msec	0 to 60000 msec	SG, C3, RB
Off Time 2	0 msec	0 to 60000 msec	SG, C3, RE
On Time 3	50 msec	0 to 60000 msec	SG, C3, RC
Off Time 3	50 msec	0 to 60000 msec	SG, C3, RF
Control	Disable	Disable or Enable	SG, E

**Table 2-43. Routing Tone Parameter Summary**

Routing tone is used in the call setup sequence by enabling the tone and by specifying a network routing delay of sufficient duration. The following example illustrates a situation in which Station B (originating station) would receive a routing tone. In this example the network routing delay is set to 6000 msec, routing tone is enabled and the telephone number for Station A is 5550123.



**Routing Tone Example:**

Station B goes off hook and receives the first dial tone after dial tone delay expires.

Station B dials 5550123 (first dial tone is turned off when 1st digit is dialed).

Station B receives routing tone for 6000 msec.(during the routing delay).

Station A receives ringing and Station B receives ringback (audible ringing) after network routing delay expires.

A single frequency routing tone can be generated by specifying frequency 1 and frequency 2 to be the same. In this case the two sine waves are summed together in phase to produce a single frequency tone with a level that is 3 dB higher than the programmed value. Routing tone level is calibrated for a dual tone signal that consists of tones of unequal frequency. Two tones of unequal frequency produce a signal that is 3 dB lower than that generated by two tones of identical frequency and phase.

A continuous tone will be generated whenever all off times of the cadence are zero and there is a non-zero on time (on time 3). A single stage cadence (one non-zero on time and one non-zero off time) should be specified using on time 3 and off time 3. A two stage cadence (two non-zero on times and two non-zero off times) should be specified using on time 2 and off time 2 for the first stage along with on time 3 and off time 3 for the second stage. A three stage cadence (three non-zero on times and three non-zero off times) should be specified using on time 1 and off time 1 for the first stage, along with on time 2 and off time 2 for the second stage and on time 3 and off time 3 for the third stage.

## Telephone Numbers

The Public Switched Telephone Network (PSTN) is emulated by the Series II when the unit is configured for 2 wire switched operation. This emulated PSTN consists of two network (station) interfaces. The network address (telephone number) of each station can be specified. This address is a sequence of numbers that identifies the station set (A or B) to which a call is directed.

The Series II supports a telephone number sequence that can be short as one character or long as fifteen characters. This dial information may be sent to the Series II using dial pulsing or Dual Tone Multi-Frequency (DTMF). Dial digits 0 to 9 are supported for both dial pulsing and DTMF (touch-tone), as well as # (pound) and \* (star) for DTMF only dialing. In addition, a "+" (plus sign) functions as a special character to control the occurrence of secondary dial tone. A telephone number may include a "+" (plus sign) at the point in the dialing sequence where the secondary dial tone is desired (see Secondary Dial Tone section above).

PARAMETER	DEFAULT	RANGE	COMMAND
Station A Number	5550123	1 to 15 characters (0 to 9, #, *, +)	SW, TA
Station B Number	5559876	1 to 15 characters (0 to 9, #, *, +)	SW, TB

**Table 2-44. Telephone Number Parameter Summary**

The Series II automatically senses the type (DTMF or dial pulsing) of signaling that is being used to send dialing information. This sensing is done on the first character of a dialing sequence. The Series II will only recognize (accept) subsequent characters that match the type of the first character.

## Dial Priority

The Central Office emulator module of the Series II receives dialing information (DTMF or dial pulsing) from only one station at a time. The emulator assigns the common DTMF/dial pulse detector to the first station (A or B) that makes an on-hook to off-hook transition, assuming that both stations are on-hook at the start. The station that does not have dial priority will not be allowed to dial. DTMF or dial pulses will be ignored and dial tone will not be interrupted.

## Network Delays

The Public Switched Telephone Network (PSTN) is emulated by the Series II when the unit is configured for 2 wire switched operation. This simulated PSTN emulates the time delays caused by network switching equipment. This includes dial tone delay, routing delay and disconnect delay.

Dial tone delay is defined for the Series II as the time between off-hook to the application of primary dial tone. It does not apply to secondary dial tone. Routing or switching delay is defined as the time between dial completion (last dial character received) and the application of secondary dial tone, ringback/ringing or busy.

Disconnect delay is defined as the time between the station device making an on-hook transition and the recognition of on-hook by the Series II. Upon recognition of on-hook the Series II will disconnect a call or signaling from the station interface.

PARAMETER	DEFAULT	RANGE	COMMAND
Dial Tone Delay	1 msec	1 to 60000 msec	SW, N
Routing Delay	1 msec	1 to 60000 msec	SW, M
Disconnect Delay	255 msec	1 to 255 msec	SW, Q

**Table 2-45. Network Delays Parameter Summary**

The Series II supports dial pulse signaling. Because a break interval is a momentary on-hook condition, caution must be exercised in selecting the disconnect delay. A delay time that is less than the break interval of the dial pulsing device would cause the Series II to interpret the break interval as a disconnect and not as a dial pulse.

### 2.11.7. Dialing Analysis Features

The Series II provides analysis of DTMF (touch-tones) and dial pulse signaling when configured for 2 wire switched configuration. DTMF and dial pulse digits from the station that has dialing priority are decoded, compared against the expected telephone number (programmed station number) and saved for readback.

#### Dial Pulse Make/Break Detection Intervals

Dial pulsing sends dialing information by generating momentary changes in hook status between an off-hook and on-hook condition. The on-hook interval is referred to as the "break" interval and the off-hook as the "make" interval. The number of make/break intervals corresponds to the value of the digit that is being dialed. For example, dialing a "4" creates four make/break intervals. A typical break interval is approximately 60 msec in length, while a make is typically around 40 msec.

The Series II decodes dial pulses by measuring the length of the make/break intervals. The measured interval is then compare against a user programmed qualification window. This window specifies a minimum and a maximum time limit. Make and break intervals that exceed these limits are ignored. The following example illustrates a situation in which the limits are exceeded.

In this example the minimum make qualification time is 25 msec and the maximum is 55 msec. The minimum break qualification time is 45 msec and the maximum is 75 msec. A modem attempts to dial a "5". Four of the break intervals dialed are 60 msec in length but one is 43 msec. In this situation the Series II would interpret the digit as a "4" instead of a "5".

PARAMETER	DEFAULT	RANGE	COMMAND
Minimum Break	45 msec	10 to 90 msec	SG, PA
Maximum Break	75 msec	10 to 90 msec	SG, PB
Minimum Make	25 msec	10 to 90 msec	SG, PC
Maximum Make	55 msec	10 to 90 msec	SG, PD

**Table 2-46. Dial Pulse Make/Break Detection Intervals Parameter Summary**

Dial pulses are typically generated by a telephone or DCE at a rate of 10 pulses per second (pps). This corresponds to a combined break and make period of 100 msec (60 msec + 40 msec). However some devices dial at rates up to 20 pps (1/20 pps = 50 msec). Dial pulses at this rate would require small minima. Selecting a minimum break and make detection interval of 10 msec and a maximum break and make of 90 msec will support most available rates.

## **Readback of Dialed Telephone Numbers**

Dial pulse and DTMF dialing information that is received from the station that has dialing priority are decoded, compared against the expected telephone number (programmed station number) and saved for readback. The maximum quantity of dialed digits that will be saved for readback is equal to the quantity of digits in the called station's telephone number. Digits that are received in excess of this quantity are ignored.

Dialed digits that are received by the Series II when Station A is originating the call can be readback with the SW, ZA command. The Station A readback buffer is cleared upon an on-hook to off-hook transition of the station. Dialed digits that are received by the Series II when Station B is originating the call can be readback with the SW, ZB command. The Station B readback buffer is cleared upon a on-hook to off-hook transition of the station.

This page intentionally left blank.

## 3.0. PROGRAMMER'S GUIDE

---

### 3.1. Overview

The Programmer's Guide section describes the information necessary to communicate with the Series II. This information includes: Definitions of all user commands with definitions of the conventions used to specify these commands, the responses returned by each command, the interface protocols used to communicate with the Series II, and commands which have been upgraded or replaced.

The Programmer's Guide is divided into 4 major sections: Command Layer Protocol, Transmission Layer Protocol, Programming Sequence, and Command descriptions (i.e. TAS Series II Network Emulator Commands For Program Cartridge Version 2.20). The 2 protocol layers (Command and Transmission) are shown below.

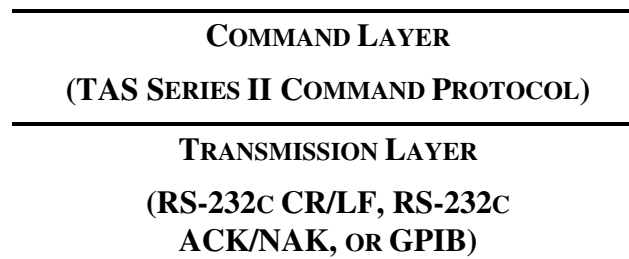

The TAS Series II command layer protocol defines the TAS Series II command language as well as the sequencing of TAS Series II commands and responses. The command language consists of definitions of the commands as well as the syntax and categories of the commands. The definitions of the commands determines the contents of the messages sent to and returned from the Series II, and determines how the state of the parameter values within the Series II can be changed. This protocol remains virtually the same regardless of the Transmission Layer Protocol used to control the simulator. The categories and syntax description of the commands are discussed in the following section on Command Layer Protocol.

The TAS Series II Transmission Layer Protocol is the handshaking and signaling that takes place to send a command to and from the Series II. It is sometimes called the interface bus. Anyone using the Series II must conform to one of the 3 Industry Standard Transmission Layer Protocols: GPIB, RS-232C Carriage Return/Line Feed (CR/LF), and RS-232C Acknowledge/Not Acknowledge (ACK/NAK).

The Programming Sequence section explains the typical TAS recommended order for programming a Series II. This section is of a general nature and should be

used with the details of the Commands in the section entitled TAS Series II Network Emulator Commands For Program Cartridge Version 2.20. For anyone unfamiliar with the Series II it is recommended reading.

The detailed descriptions of the individual commands are defined in the section entitled TAS Series II Network Emulator Commands For Program Cartridge Version 2.20. These commands are how the information is sent over the Command Protocol Layer and each command controls one or more parameters of the Series II.



## 3.2. TAS Series II Command Layer Protocol

The TAS Series II command protocol provides the means for a host computer to control the TAS Series II. The command protocol defines a set of simple, readable, high-level commands for TAS Series II control. For example, the system controller turns on the white noise source at 62.0 dBn by sending the command:

```
/RN, L620, S1/
```

And the TAS Series II responds:

```
/C/
```

to indicate successful execution of the command.

This section describes the command types and command message format (or command syntax) necessary for the Series II to understand the command, and the responses returned from the Series II. The section on special commands is to help the User understand special features particular to the Series II and not part of the Network Simulation.

### 3.2.1. Command Types

The TAS Series II command protocol supports 3 types of command messages: Execute, Report, and Set.

Execute commands are accepted by the Series II, complete an assigned task, and response with a command completed message (*/C/*). Examples of Execute commands are: Trigger commands (*/IMP1,T/GH,T/PH,T/*) which send a single instance of the feature, System self diagnostic command (*/IO,C/*) which calibrates and resets the Series II, and Automatic Gain Control (AGC) commands (*/IO,A1,A0,G1,G0/*) which perform the AGC function and return control to the User.

Report commands are accepted by the Series II, then the correct parameter values are retrieved or measured and returned to the User for review. Report commands are not connected with internal Series II parameter values. Report commands do not contain data parameters, but they can contain identifiers to define a subset of the Series II. Examples of Report commands are: System Administration Report command (*/AD,R/*) which responds with Series II system information, Input/Output Attenuator Readback command (*/IO,IR,RR,LR,TR/*) which responds with the associated attenuator level setting, and System Administration Version command (*/AD,Vvv/*) which uses an identifier to respond with the correct module version number.

Set commands contain parameter values which will be stored within the Series II (internal Series II parameters). These parameter values configure the state of a

Series II feature to create the desired Network configurations. The majority of User commands are Set commands. Examples of Set commands are: Tone Generator frequency and On/Off controls (/TN,F1004,S1/), and Amplitude Jitter level and frequency commands (/AJ,L1234,F600/) which sets the amplitude jitter level and frequency for the network emulation.

If the Series II is unable to complete any command, an error message will be returned to the User regardless of the Command Type.

### 3.2.2. Command Message Format

Figure 3-1 provides an exploded view of a TAS Series II command frame message.

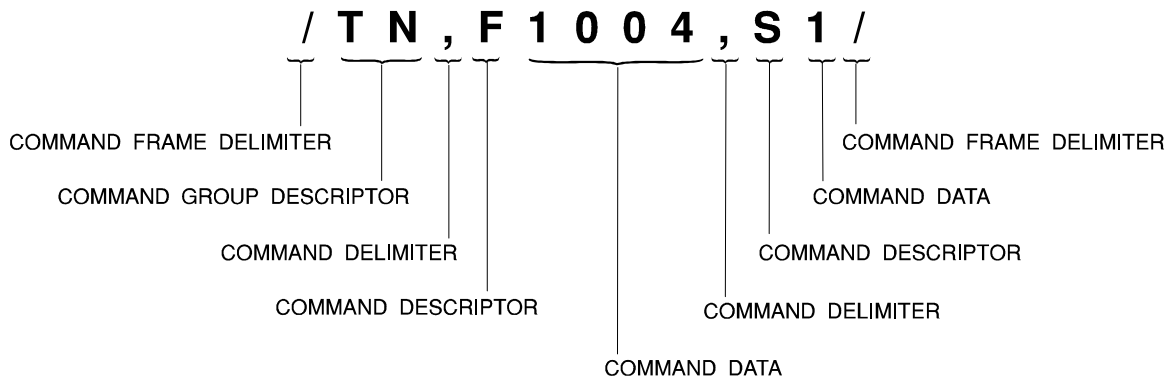

**Figure 3-1. Command Frame Format**

The backslashes (/) in the command message are the Command Frame delimiters. Command Frames may be concatenated, subject to a maximum of 128 characters per message. A command message ends with a carriage return (i.e. ENTER).

The alphanumeric characters after the first Command Frame delimiter are the Command Group descriptors. The Command Group descriptors are usually 2 or 4 alphanumeric characters in length. The commas (,) are Command delimiters and define where one Command or Command Group stops and another command starts. Commands may be concatenated within a Command Group and may appear in any order within a Command Frame.

The TN in Figure 3-1 is the Command Group, and the F and S in Figure 3-1 are Command descriptors. The alphanumeric characters following each Command descriptor constitute the Command parameter value (i.e. data). The number of the alphanumeric characters in the Command parameter field is determined by the format of the Command (see Programming Sequence section).

### 3.2.3. Response Formats

#### Completion Message

The TAS Series II provides a command completed response message to indicate the successful completion of an Execute or Set command message. The syntax of this message is:

/C/

The TAS Series II provides only one such response for each command message, even if the command message consists of concatenated command frames. All Commands must be completed successfully in order for the successful completion command message to be returned to the User. Error response messages have priority over successful completion messages.

#### Report Response Message

The TAS Series II provides a Report response message unique to each Report Command. Since the Series II only returns one message to the User, only the first Report Command will be returned to the User and the remaining Report Commands will be executed but will not return their responses. If a Report Command is concatenated with Execute or Set Commands, the Report Command will return the message to the user and the successful completion message will not be sent to the user. Error response messages have priority over successful completion messages.

#### Error Message

The TAS Series II returns an error message whenever it encounters an error condition while processing a command message. For example:

/TN01, E001/

This message indicates the TAS Series II encountered an error condition while processing the TONE command. Note that the error message contains the command descriptor (TN01) for the command in error. The three digits which follow the E are the error number. See the Section of Error Codes for an explanation of the error values returned.

The TAS Series II executes a command message sequentially. When the TAS Series II encounters an error condition, it ceases processing the command message, and provides the appropriate error message. The TAS Series II executes all Command Groups and Commands up to the point of error. The unit does not execute Commands or Command Groups which are beyond the point of error.

### 3.2.4. Special Commands

The TAS Series II command protocol defines 3 special commands. These messages represent slight departures from the normal rules for processing Series II commands.

#### System Administration Report Command

The first special command is the System Administration Report command: /AD,R/. This command causes the Series II to report software version, power-up diagnostic status, options, and model number. The normal TAS Series II response to this command is:

```
/AD16 , Vvvv , Rrrr , Oooooooooo , Mmmmmm /
```

When this command is executed from the system controller, it is executed like any other Report Command; however, the TAS Series II automatically prepares the system administration response message whenever it is reset. The TAS Series II provides this reset message in response to the next poll (or next inquiry in CRLF protocol). The TAS Series II does not accept new commands until the system controller polls for this message. Information contained in the response indicates the TAS Series II version number, options present, and model number.

#### Software Straps

The second special command is the Software Straps which allows specific features to be selected by the User. There are seven choices which are: IEEE or Bipolar impulse noise, Proprietary or TAS 1010 Compatible Intermodulation Distortion algorithm, TAS 1010 Compatible or Enhanced Gain Delay filters, 2 mA or 6 mA loop current steps, 5 Vrms or 1 Vrms Ring Voltage steps, and central office mode. See /AD,Sjj=ss/ command for further details.

#### Attenuator Readback

The third special command is Attenuator Readback which returns to the user the current level setting of the input or output hardware attenuator (attenuation or gain). This feature allows the user to determine the value of the transmission channel attenuators after an AGC has been completed. See /IO,LR,IR,RR,TR/ commands for further details.

### 3.2.5. Parameter Value Readback

The Series II provides the capability to readback user programmable parameter values. The information that is returned may be dependent upon the System Administration impairment generator selection command (/AD,I/). If i=1 or 3, generator 1 is selected for readback, and if i=2, then generator 2 is selected for readback. Generator 1 is typically configured to provide impairment simulation in the A to B direction, while generator 2 supports the B to A direction.

The following list contains all commands that provide readback capability:

AD - I,S,jj,T,V	LC - Bj,D,E,H,Ij,Lj,M,R,S,V
AJ - F,L,S,W	MC - D,I,S
AP - SA,SB,TA,TB,Xj,Yj,LA,LB,LC,LD	MIC1 - D,I,S
AXE1 - D,L, T, S	MIC2 - D,I,S
AXE2 - D,L,T,S	NL - C,M,Q,X,Y
EC - Lj,Pj,S	PC - B,Cj,D,E,I,M,P,Qj,S
ED - D,Lj,Pj,X,Y	PH - D,I,L,M,R,S
EP - Cj,Qj,M,P,I,O,T,U,B,R,E,S,L	PJ - F,L,S,W
FS - F,M,S	RN - B,L,P,S,W
GD - W,X,Y,Z	SAT1 - D,S
GH - D,I,L,M,R,S	SAT2 - D,S
IM - I,L,M,P,S,W	SF - F,I,L,M,P,Q,S,X,Y
IMP1 - I,L,M,P,S,W	SG-A,Bj,C,D,E,Fj,I,Ji,Kj,L,M,Pj,Q,Rj,S,W,Y
IMP2 - D,I,L,M,P,S	SW - M,N,Q,S,Tj
IO - D,E,F,I,J,L,M,N,R,S,T,V	TN - F,S

#### Readback Command Format

The value of programmable parameters can be retrieved over the RS-232 or IEEE-488 remote control interface of the Series II. The format of the readback command is the same as that for programming the parameter value, except the parameter data is omitted. The following examples illustrate the readback command format for several typical commands.

/AD, I/

The above command returns the selection of the impairments generator, regardless of whether generator 1, generator 2 or both generators are selected for programming or readback.

/EC, LC/

The above command returns the level setting of the station B near end echo attenuator. The C associated with the command parameter L selects the particular echo attenuator.

*/GD, W/*

The above command reads back the identification number for the selected gain filter #2. The value returned is dependent upon the last programming or readback direction selection command (*/AD,I1/* or */AD,I2/* or */AD,I3/*). If I3 is the command parameter sent, then generator 1 is selected for readback.

*/SG, FA/*

The above command reads back the frequency of dial tone frequency 1. The A associated with the command parameter F selects the particular type of tone and whether the frequency is 1 or 2.

### **Readback Response Format**

The readback command response returns the selected parameter information to the user. The following provides possible responses to the four previous readback command examples.

*/AD16, I2/*

Impairments generator 2 is selected for programming or readback.

*/EC30, LC200/*

The station B near end echo attenuator is set to a level of 20.0 dB attenuation.

*/GD17, W13/*

The gain filter #2 is set to "Worst case" CCITT M1020 Gain Characteristic.

*/SG20, FA4800/*

The dial tone frequency 1 is set to 480.0 Hz.

### 3.3. Transmission Layer Protocols

This section describes the 3 Transmission Layer Protocols available to communicate with the TAS Series II: GPIB, RS-232C CR/LF and RS-232C ACK/NAK. These protocols define the control characters and sequence of events which allow a message to be sent to and from the Series II. The Series II user command (See Command Layer Protocol section) is contained within these control characters. All Protocols provide a TAS Series II response for every system controller command to the TAS Series II. The TAS Series II does not process a new command from the system controller until it completes the processing of a pending command.

In order to activate a specific protocol, the Rear Panel Switches must be properly configured followed by the AC Power being turned on. See Section 2, Rear Panel Features for further Rear Panel Switches details.

#### 3.3.1. RS-232C CR/LF Protocol

The TAS Series II Carriage Return/Line Feed (CR/LF) protocol allows simple, dumb terminal control of the Series II. To select the CR/LF protocol, set the dip switches at the rear of the TAS Series II to all ones. The communication format is 7 data bits, odd parity, 1 stop bit, 1200, 2400, 4800, or 9600 bps.

To enter a command at the terminal, simply type the command in response to the ">" prompt, followed by <RETURN> (i.e. "CR", Carriage Return or Enter). The TAS Series II executes the command and sends the response back to the terminal as a series of ASCII characters.

#### Polling for a Response

The TAS Series II automatically provides a response whenever it receives a command from the terminal. It also automatically provides the system administration message whenever it is powered on or reset. In the CR/LF protocol, the terminal or controller does not have to explicitly poll for a TAS Series II response.

#### Sending Commands to the TAS Series II

To send a command to the TAS Series II, simply type the command, followed by <RETURN>.

## Receiving Responses from the TAS Series II

The TAS Series II automatically provides a response for every command. Some commands, such as MEASURE and AGC, take several seconds to complete. The Series II sends the response to such commands back to the terminal after it has completed processing the command.

### 3.3.2. TAS Series II ACK/NAK Protocol

The TAS Series II ACK/NAK protocol supports RS-232C multipoint communication between a system controller and one or more TAS Series II units. The controller initiates all transactions. To communicate with a TAS Series II, the system controller must perform the following steps:

1. Poll the TAS Series II for pending response or system reset message.
2. Send the message, with address, control characters, and block checksum, to the TAS Series II.
3. Poll the TAS Series II for the command response.

The following is an example of a system controller-TAS Series II command transaction.

Controller polls for pending response:

```
[a1] [a0] p <ENQ>
```

TAS Series II responds:

```
[a1] [a0] <EOT>
```

Controller sends command:

```
[a1] [a0] s <ENQ> <SOH> <STX> command <ETX>
[b2] [b1] [b0]
```

TAS Series II responds:

```
[a1] [a0] <ACK>
```

Controller polls for response:

```
[a1] [a0] p <ENQ>
```

TAS Series II responds:

```
[a1] [a0] <SOH> <STX> response <ETX> [b2] [b1] [b0]
```



**NOTE:** Spaces in the previous examples are for clarity only. There are no spaces between command fields. The [ax] and [bx] fields are the address and block checksum fields, respectively. The "<>" denote ASCII control characters. The "p" indicates a poll message, and the "s" indicates a select message. The block check field is the two's complement of the checksum of all characters from the first address character through the <ETX> character. This sum is represented in three ASCII-decimal digits. For example, if the checksum is 201, then the block checksum should be 055 (256 - 201).

### Polling for a Response

When the TAS Series II receives a command from the controller, it executes the command and prepares a response. The controller must poll the TAS Series II to receive this response. The poll sequence is:

[a1] [a0] p <ENQ>

The controller must pad the address field on the left with a space (hex 20). The controller should be prepared to handle one of three possible results.

1. No response.
2. No message:

[a1] [a0] <EOT>

3. Response:

[a1] [a0] <SOH> <STX> response <ETX> [b2] [b1] [b0]

The TAS Series II does not respond to a poll if it is configured illegally, if it detects an error in the poll message, or if it is not turned on. If the system controller does not receive a response from the TAS Series II, it should poll again. The TAS Series II gives a no message response if it has no response pending.

### Sending Commands to the TAS Series II

To send a command to the TAS Series II, the system controller must form a string which consists of the Series II address, the select character "s", the ASCII control characters, the command, and a block checksum, as follows:

[a1] [a0] s <ENQ> <SOH> <STX> command <ETX> [b2] [b1] [b0]

The system controller must be prepared to handle one of three possible results:

1. No response.
2. Negative acknowledge:

[a1] [a0] <NAK>

3. Positive acknowledge:

[a1] [a0] <ACK>

The TAS Series II does not respond to the command if it is not addressed properly, if it is off, or if it detects an error in the command message control characters.

The Series II responds with a negative acknowledgment (NAK) if it detects a transmission error in the command message (bad block sum), or if the command message is too long (greater than 128 characters). In this case, the controller should send the command message again.

The block sum is represented in ASCII-decimal on the control link, and is the two's complement of the module 256 sum of all the characters in the message, up to and including the <ETX> control character.

The TAS Series II returns a positive acknowledgment (ACK) when it detects no message transmission errors.

### **Receiving Responses from the TAS Series II**

The TAS Series II provides a command response when it is polled by the system controller. If the system controller detects a transmission error in the TAS Series II response, it should poll the TAS Series II, send the message again, and poll again for the response.

### 3.3.3. TAS Series II GPIB Protocol

The TAS Series II GPIB protocol supports a bus communication architecture in which the TAS Series II Telephone Network Emulator is one of the devices being controlled. The system controller initiates all transactions. To communicate with the TAS Series II, a GPIB system controller must perform the following steps:

1. Poll the TAS Series II for a pending response or the system reset message.
2. Send the message to the TAS Series II.
3. Poll the TAS Series II for the command response.

The system controller must meet all GPIB electrical and mechanical specifications.

The IEEE 488-1978 standard defines the GPIB interface functions and the subsets of those functions. The TAS Series II implements the subset indicated in Table 3-1.

FUNCTION	DESCRIPTION	SERIES II
SH1	source handshake	full capability
AH1	acceptor handshake	full capability
T6	talker function	basic talker, serial poll unaddress if My Listen Address (MLA) is received
TEO	extended talker	no capability
L4	listener function	basic listener, unaddress if My Talk Address (MTA) is received
LEO	extended listener	no capability
SR1	service request	full capability
RLO	remote-local	no capability Series II is always in remote mode
PPO	parallel poll	no capability
DCO	device clear	no capability
DTO	device trigger	no capability
CO	controller	no capability

**Table 3-1. GPIB Subsets**

The TAS Series II provides a GPIB status byte to indicate its current state. The TAS Series II states are:

1. Idle - 02H.
2. Busy - 01H.
3. Ready To Respond (RTR) - 04H or 44H.

### **Idle**

This state indicates that the TAS Series II does not have a message to send and is ready to accept a command.

### **Busy**

This state indicates that the TAS Series II is currently processing a command. The TAS Series II does not accept a new command until it has finished processing the current command and has provided the response to the controller.

### **Ready To Respond (RTR)**

This state indicates that the TAS Series II currently has a message to send to the controller. The TAS Series II is always **READY TO RESPOND** when power is first applied, when it is reset, or when it has finished processing a command. When the TAS Series II is ready to respond, it activates the service request line (SRQ), and the RTR status = 44H. After the controller conducts the serial poll, SRQ goes inactive, and the RTR status equals 04H. Figure 3-2 shows a flowchart for a typical bus controller sequence.

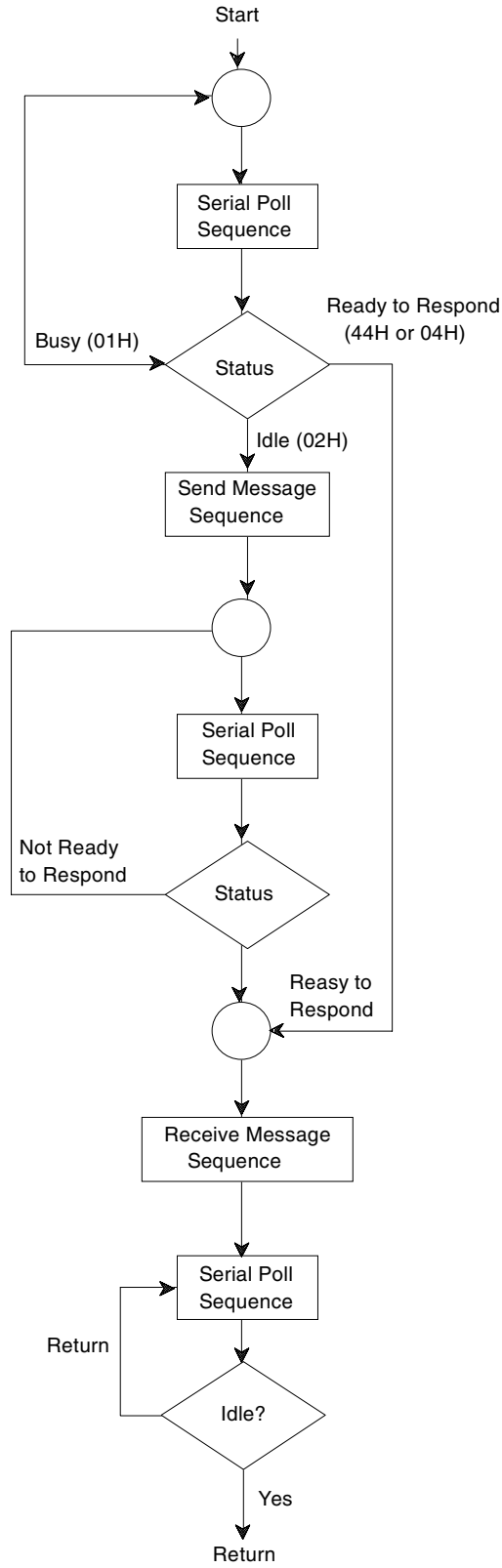

Figure 3-2. GPIB (IEEE-488) Bus Controller Sequence

### **Polling for a Response**

The following list contains typical bus events required to effect a serial poll of the TAS Series II. Your actual bus sequence may be different:

1. ATN active
2. UNT - (UNTalk)
3. UNL - (UNListen)
4. SPE - (Serial Poll Enable)
5. MTA - (TAS Series II My Talk Address)
6. System controller programmed to listen
7. ATN inactive
8. TAS Series II sends status
9. ATN active
10. SPD - (Serial Poll Disable)
11. UNT - (UNTalk)

Always conduct a serial poll before sending a command to the TAS Series II. If the TAS Series II has a pending message to send, it does not accept a new command.

### **Sending Commands to the TAS Series II**

The following list contains typical bus events required to send a command to the TAS Series II. Your actual bus sequence may be different:

1. ATN active
2. UNT - (UNTalk)
3. UNL - (UNListen)
4. MLA - (TAS Series II My Listen Address)
5. System controller programmed to talk
6. ATN inactive
7. System controller sends command to TAS Series II, and asserts EOI with last command character
8. ATN active
9. UNL - (UNListen)

Command strings must not be terminated with <CR> or <CR><LF>. The system controller signals the end of a command string by asserting EOI (end of interrupt) while it sends the last character of the command.

Some commands require several seconds of TAS Series II processing time. While most commands complete in less than 100 msec, commands such as AGC, MEASURE, and CALIBRATE may require up to 50 seconds. The system controller should conduct serial polls until it detects that the TAS Series II status equals RTR.

### **Receiving Responses from the TAS Series II**

The following is a list of typical bus events required to receive a response from the TAS Series II. Your actual bus sequence may be different:

1. ATN active
2. UNT - (UNTalk)
3. UNL - (UNListen)
4. MTA - (TAS Series II My Talk Address)
5. System controller programmed to listen
6. ATN inactive
7. TAS Series II sends data to system controller
8. System controller re-asserts control when EOI goes active
9. ATN active
10. UNT - (UNTalk)

The TAS Series II does not terminate its response message with a <CR> or <CR><LF>. The unit signals the end of a response message by raising EOI while it sends the last character of the response.

### **3.4. Programming Sequence**

The TAS Series II contains two major subsystems: the Central Office (CO) Simulator and the Transmission Channel Simulator. The Central Office Simulator implements telephone network configuration and central office functions, and the Transmission Channel Simulator generates telephone network trunk impairments. A controller should configure each of these subsystems before executing a test. A typical programming sequence is detailed below:

1. Set Network Configuration (4W private, 2W private, 2W autoswitched, or 2W switched).
2. Set CO network simulator switching parameters.
3. Set CO network simulator signaling parameters.
4. Set up Test Channel Configuration.
5. Set transmission channel input/output configuration.
6. Set transmission channel impairment parameters.
7. Execute test.

#### **3.4.1. Transmission Channel Impairments**

The TAS Series II provides programmable channel impairments, such as noise, gain distortion, envelope delay distortion, etc. These impairments are controlled by issuing commands from a control computer to one of the TAS Series II control interfaces (RS-232C or GPIB). The control program must assign a value to each impairment parameter for every impairment function activated or the Series II assigns the default parameter to that value.

The default on/off condition for all impairments is off and therefore the impairments will not be listed here. To turn the impairments on and set their parameter values, see the section on Command definitions entitled TAS Series II Network Emulator Commands For Program Cartridge Version 2.20.



## Transmission Channel Configuration

The IO command controls the transmission channel input/output configuration. The system controller should always configure the transmission channel before using it to ensure that input and output levels are set correctly, and that the transmission channel input source is correctly specified. The TAS Series II control processor module calibrates the transmission channel automatically during initialization, but the IO command provides a means of additional calibration. Table 3-2 gives the power-up defaults for the transmission channel input/output configuration:

COMMAND: IO	
L-180	A→B output level -18.0 dBm
T-130	B→A output level -13.0 dBm
M1	A→B external source
S1	B→A external source
I-100	A→B nominal input level -10.0 dBm
R0	B→A nominal input level 0.0 dBm

**Table 3-2. Transmission Channel Input/Output Defaults**

### 3.4.2. Test Channel Configuration Control

The TAS Series II provides programmable Test Channel Configurations to meet the requirements of different modem testing standards. The selection of the appropriate Test Channel Configuration is done over the control interface by sending the System Administration Test Channel Configuration command to the Series II.

#### System Administration Test Channel Configuration

The /AD,Tt/ command controls the Test Channel Configuration of the impairment modules of the telephone network emulator. The selections (t =) are as follows:

- 0 - EIA/CCITT Test Channel Configuration.
- 1 - ETSI-1, NET 20 Test Channel Configuration 1.
- 2 - ETSI-2, NET 20 Test Channel Configuration 2
- 3 - Analog Bypass Test Channel Configuration

Default is 0 (EIA/CCITT).

### 3.4.3. Basic Central Office Simulator

The Central Office (CO) simulator module simulates network configuration and central office functions and handles the call processing and signaling functions. If the system controller specifies 4-wire private line operation, the CO simulator provides a dedicated, 600 ohm, 4-wire circuit. If the system controller specifies switched operation, the CO simulator provides two switched-network stations with adjustable central office parameters. Once the switched-network parameters are set, the controller does not have to interact with the TAS Series II

#### Line Control

The LC command controls the CO simulator line configuration. The system controller should invoke this command as a first step toward controlling the TAS Series II to ensure proper line setup. The LC command allows you to specify the Network Configuration (2W or 4W), reverse channel attenuation, reverse channel mode, simulation direction, etc. Table 3-3 gives the default line configuration:

COMMAND: LC	
AA0	station A transmit port external access disabled
AB0	station A receive port external access disabled
AC0	station B transmit port external access disabled
AD0	station B receive port external access disabled
BA0	station A internal 604-ohm hybrid balance network
BB0	station B internal 604-ohm hybrid balance network
D0	direction normal
E0	internal reverse channel
IA0	station A not isolated
IB0	station B not isolated
LA1	station A high loop resistance
LB1	station B high loop resistance
M0	4W private line
S0	current source selected
V0	45 volt battery selected
W0	floating battery voltage reference
XA1	station A loopback relay closed (4W private line)
XB1	station B loopback relay closed (4W private line)
YA0	station A program resistor relay open
YB0	station B program resistor relay open

**Table 3-3. Line Control Defaults**

## Switching

The SW command controls network switching parameters, such as telephone numbers and switching delay time. Table 3-4 gives the default switch configuration:

COMMAND: SW	
TA5550123	station A tel. no.
TB5559876	station B tel. no.
M1	1 msec switch delay
N1	1 msec dial tone delay
Q255	255 msec on-hook recognition delay

**Table 3-4. Default Switching Parameters**

## Signaling

The SG command controls central office signaling parameters, and allows the system controller to interrogate line status. Signaling is usually generated automatically during call processing, but the system controller may also force signaling manually. The S subframe selects and sends a signal to the designated station. This command option may be used to determine the ability of the device-under-test to detect signaling. This command option should not be used under normal circumstances, since it disables the signaling associated with automatic call processing.

The Z subframe directs the TAS Series II to report the status of the designated station. For example, the system controller can invoke this command to verify that a station goes off-hook after it receives ringing. Table 3-5 lists the default signaling parameters:

### Command: SG

A85	ring voltage: 85 Vrms
BA10	busy on time: 0.5 sec
BB10	busy off time: 0.5 sec
D-10	Primary and Secondary dial tone and Routing tone level: -10 dBm
E0	disable call routing tone
FC4800	busy freq. 1: 480 Hz
FD6200	busy freq. 2: 620 Hz
FE4400	audible ring freq. 1: 440.0 Hz
FF4800	audible ring freq. 2: 480 Hz
I3	station A & B DC loop current: 18 mA

JA9 station A DC loop Current: 18 mA  
 JB9 station B DC loop Current: 18 mA  
 KA0 station A loop current polarity positive  
 KB0 station B loop current polarity positive  
 L17 ring voltage: 85 Vrms  
 MC Clear station status  
 PA45 min. break interval: 45 msec  
 PB75 max. break interval: 75 msec  
 PC25 min. make interval: 25 msec  
 PD55 max. make interval: 55 msec  
 Q0 Ringing DC Bias: Battery Voltage  
 SG station signaling clear  
 W0 ringing signal polarity positive  
 Y200 ring freq.: 20 Hz

**SG,C0 Primary Dial Tone and Ringing Parameters**

FA3500 primary dial tone freq. 1: 350.0 Hz  
 FB4400 primary dial tone freq. 2: 440.0 Hz  
 RA0 ring on time 1: 0 sec  
 RB0 ring on time 2: 0 sec  
 RC40 ring on time 3: 2 sec  
 RD0 ring off time 1: 0 sec  
 RE0 ring off time 2: 0 sec  
 RF80 ring off time 3: 4 sec

**SG,C1 Primary Dial Tone Parameters**

FA3500 primary dial tone freq. 1: 350.0 Hz  
 FB4400 primary dial tone freq. 2: 440.0 Hz  
 RA0 primary dial tone on time 1: 0 sec  
 RB0 primary dial tone on time 2: 0 sec  
 RC4 primary dial tone on time 3: 200 msec  
 RD0 primary dial tone off time 1: 0 sec  
 RE0 primary dial tone off time 2: 0 sec  
 RF0 primary dial tone off time 3: 0 sec

**SG,C2 Secondary Dial Tone Parameters**

FA3500 secondary dial tone freq. 1: 350.0 Hz  
 FB4400 secondary dial tone freq. 2: 440.0 Hz  
 RA0 secondary dial tone on time 1: 0 sec  
 RB0 secondary dial tone on time 2: 0 sec

RC40	secondary dial tone on time 3: 2 sec
RD0	secondary dial tone off time 1: 0 sec
RE0	secondary dial tone off time 2: 0 sec
RF0	secondary dial tone off time 3: 0 sec
<b>SG,C3</b>	<b>Routing Tone Parameters</b>
FA4400	routing tone freq. 1: 440.0 Hz
FB4400	routing tone freq. 2: 440.0 Hz
RA0	routing tone on time 1: 0 sec
RB0	routing tone on time 2: 0 sec
RC1	routing tone on time 3: 50 msec
RD0	routing tone off time 1: 0 sec
RE0	routing tone off time 2: 0 sec
RF1	routing tone off time 3: 50 msec

**Table 3-5. Default Signaling Parameters**

### 3.5. TAS Series II Commands for Program Cartridge Version 2.20 and Higher

TAS Series II network emulator commands and command responses allow you to completely control network simulator operation. The commands are the same if you control the network simulator by the RS-232C Carriage Return/Line Feed protocol, the RS-232C ACK/NAK protocol, or the GPIB protocol. The commands the network simulator can implement depend on the model and equipped options.

#### 3.5.1. Conventions to Specify Commands

When programming the Series II from the commands listed within this manual, several conventions must be observed:

Commands must start and end with a '/'.

Commas (',') are necessary between command Groups and commands, and between commands.

The characters shown as upper case letters in the command descriptions must be sent to the Series II, but they can be either upper or lower case (i.e. the Series II is now case insensitive). Examples of valid commands:

`/AJ,L20/` or `/aj,l20/`, `/FS,S1,F1004/` or `/fs,s1,f2004/` or `/FS,f502,s1/`, `/lc,bA1,yB0/` or `/LC,BB1,YA0/` or `/LC,Ba1,yb0/`.

The characters shown as lower case letters in the command descriptions must be replaced by alphanumeric characters (i.e. a letter or a number) from the input values specified by the range or set of acceptable parameter values. Examples of valid commands:

`/SG,A1/` or `/SG,A100/`, `/IMP2,L-200/` or `/IMP2,L+50/`, `/GD,W0,X9,Y27,Z32/`.

Characters within the '<' and '>' symbols are optional. The symbols '<' and '>' are not valid input characters to the TAS Series II and are only used to denote optional input values.

The '/' character between '<' and '>' characters defines an either-or situation. The Series II will accept either the character before or after the '/', but not both.

Equal signs ('=') are not acceptable at this time except with the `AD,Sjj=ss` command where the '=' sign is optional.

Decimal points are not accepted at this time.

### 3.5.2. Impairment Command Group Overview

There are different impairment commands designated to control the available features within each Test Channel Configuration. Table 3-6 specifies the commands that are available in each test configuration. Commands not listed in Table 3-6 are not affected by a change in Test Channel Configuration. For details on the Commands themselves, see section 3.6. Command Descriptions in the Operations Manual.

COMMAND	TEST CHANNEL CONFIGURATIONS			
	0	1	2	3
/AD,Tt/ t =	EIA/CCITT	ETSI-1	ETSI-2	Analog Bypass
Aux Echo	AXE1	AXE1	AXE2	---
Echo (Near/Far)	ED,EC	EC	EC	EC
Interruptions	MC, MIC1	MIC1	MIC2	---
Satellite Delay	ED, SAT1	SAT1	SAT2	---
SFI	SF	SF	SF	---
Frequency Shift	FS	FS	---	---
Nonlinear Distortion	NL	NL	NL	---
Phase Jitter	PJ	PJ	---	---
Phase Hits	PH	PH	---	---
Gain Hits	GH	GH	---	---
Amplitude Jitter	AJ	AJ	---	---
Gain/Delay Distortion	GD	GD	---	---
if AD,S01=00 Impulse Noise (IEEE)	IM,IMP1	IM,IMP1	IM,IMP1	---
if AD,S01=01 Impulse Noise (Bipolar)	IMP2	IMP2	IMP2	---

**Table 3-6. Commands versus Test Channel Configurations**

/AD,S01=ss/ selects impulse independent of Test Channel Configuration.

AXE1 is independent from AXE2.

MC,MIC1 is independent from MIC2.

SAT1 (and /ED,Ddddd,Yy/) is independent from SAT2.

### 3.6. Command Descriptions

This section details the definition of the Series II Remote Control Commands. All commands are listed in alphabetic order and are recommended for use when programming new Series II applications. For Series II model 1200L the following command groups are not applicable: AJ, AXE1, AXE2, FS, GD, GH, IMP1, IMP2, MIC1, MIC2, NL, PH, PJ, SAT1, SAT2, SF; as are the following commands within the AD command group: /AD:S01=ss, S02=ss, S03=ss, Tt/.

#### 3.6.1. System Administration

##### Command Format:

*/AD, O, R, Qq, Vvv, Ii, Cc, Sjj=ss, Tt/*

##### Command Group Description:

Controls the selection of the impairment generator to be programmed, Test Channel Configuration, and Software Straps (S Registers) as well as reports model number, software version, power-up diagnostic status, options, and hardware compatibility information.

##### Command Definitions:

**O** - causes the network simulator to report system options as a 32 bit numeric string.

**R** - causes the network simulator to report software version, power-up diagnostics status, options, and model number. Note that this command contains no parameter.

**Qq** - causes the network simulator to query for installed options. The response will be in the form of; 0 (option not installed) and 1 (option installed). The query option selections are as follows;

- 1 = PCM module 1.
- 2 = PCM module 2.
- 3 = CAM option.
- 4 = UCO option.
- 5 = EPAL option.
- 6 = Cellular Audio Processing option.

**Ii** - selects the impairments generator to be programmed. The selections are as follows:

- 1 = selects impairments generator 1 for programming
- 2 = selects impairments generator 2 for programming
- 3 = selects both impairments generators 1 and 2 for programming
- Default is 1 (impairments generator 1)



**Unidirectional** impairment simulator models only support impairment generator 1, which may be configured for the A→B or B→A transmission direction (see /LC,Dd/ command).

**Bidirectional** impairment simulator models support both impairment generators 1 and 2. Impairment generator 1 is dedicated to the A→B direction, and impairment generator 2 is dedicated to the B→A direction.

**Cc** - selects the station to be controlled while in UCO (Universal Central Office) emulation mode (see /AD,S07=01/). The selections are as follows:

- 1 = selects station A for control by UCO commands.
  - 2 = selects station B for control by UCO commands.
  - 3 = selects both station A & B for control by UCO commands.
- Default is 1 (UCO factory default).

**Sjj=ss** - Selects which features are enabled. If a feature is not enabled, it can be updated but will not affect the signal path until enabled.

jj = 01 - selects between enabling the IEEE or Bipolar impulse noise  
 ss = 00 is IEEE impulses (see IMP1 command)  
 ss = 01 is Bipolar impulses (see IMP2 command)

jj = 02 - selects between the enabling the TAS 1010 Compatible or Proprietary IMD algorithms (see NL command)  
 ss = 00 is the TAS 1010 Compatible IMD algorithm  
 ss = 01 is the Proprietary IMD algorithm

jj = 03 - selects between enabling the Enhanced or 1010 Compatible Gain/Delay curves (see GD command)  
 ss = 00 is the Enhanced gain/delay curves  
 ss = 01 is the 1010 Compatible gain/delay curves

jj = 04 - selects the step size of the loop current generator current source  
 ss = 00 is for 6 mA steps (see /SG,I/ command)  
 ss = 01 is for 2 mA steps (see /SG,J/ command)

jj = 05 - selects the ringing generator step size  
 ss = 00 is for 5 Vrms steps (see /SG,L/ command)  
 ss = 01 is for 1 Vrms steps (see /SG,A/ command)

jj = 07 - selects the central office emulation mode  
 ss = 00 is for Basic Central Office emulation  
 ss = 01 is for Universal Central Office emulation (available on units with UCO option)  
 Default is ss = 00 for all settings.

**Tt** - (Test Channel Configuration) Configures the impairment modules of the telephone network emulator for compatibility with the selected standards body. The selections (t) are as follows:

- 0 - EIA/CCITT Test Channel Configuration
  - 1 - ETSI-1, NET 20 Test Channel Configuration 1
  - 2 - ETSI-2, NET 20 Test Channel Configuration 2
  - 3 - Analog Bypass Test Channel Configuration (see sect. 1.3.3. and table 2-3)
- Default is 0 (EIA/CCITT)

See Table 3-6 for the impairment modules that apply for each test channel configuration

**Vvv** - causes the Series II to report the version number of the indicated (vv) module.

- vv = 00 Reserved (fixed response is 10)
- 01 Network Simulator Module (NIM 2A)
- 02 Reserved (fixed response is 10)
- 03 Satellite Delay/Echo Module (1010-2) (fixed response = 20)
- 04 Advanced Gain/Delay Module (1010-3) (fixed response = 20)
- 05 A→B PCM/ADPCM Module
- 06 B→A PCM/ADPCM Module
- 07 A→B Signal Processor (SP3A #1)
- 08 B→A Signal Processor (SP3A #2)
- 09 Extended PCM/ADPCM Module (EPAL)
- 10 Cellular Audio Processing Module (CAP)

**Response Formats:**

```

/AD16,Vvvv,Rrrr,Oooooooooo,Mmmmm/ (R command)
    or
/AD16, Ooo...oo/
    or
/AD16,Vvvv/ (V command)
    or
/AD16,Eeee/
    or
/C/
    
```

**Response Command Definitions:**

**Vvvv** - contains the firmware version number. The version is vvv. (r command)

**Ooooooooo** - contains the options configuration. If the option is present, the corresponding digit is a 1; otherwise the corresponding digit is a 0. (r command)

The options digits, from left to right, are:

- 01 Reserved (fixed response = 0)
- 02 Network Simulator Module (NIM 2A) (fixed response = 1)
- 03 Reserved (fixed response = 0)
- 04 Satellite Delay/Echo Module (fixed response = 1)
- 05 Advanced Gain/Delay Module (fixed response = 1)
- 06 PCM/ADPCM Module # 1 (0= not present; 1= present)
- 07 PCM/ADPCM Module # 2 (0= not present; 1= present)
- 08 Channel Access Module (0= not present; 1= present)

**Ooo...oo** - reports the system options to the network simulator with a 32 bit numeric string. (r command) The options report digits are as follows:

- 01 Reserved (fixed response = 0)
- 02 Network Simulator Module (NIM 2A) (fixed response = 1)
- 03 Reserved (fixed response = 0)
- 04 Satellite Delay/Echo Module (fixed response = 1)
- 05 Advanced Gain/Delay Module (fixed response = 1)
- 06 PCM/ADPCM Links Module #1
- 07 PCM/ADPCM Links Module #2
- 08 Channel Access Module
- 09 Extended PCM/ADPCM Links Module
- 10 Cellular Audio Processing Module
- 11-32 Reserved (fixed response = 0)

**Mmmmmm** - contains the model number of the Series II with which the current software cartridge is compatible. (r command)

**Rrrr** - reports the system power - vp error code. RØØØ indicates no error. (r command)

### 3.6.2. Amplitude Jitter

#### Command Format:

`/AJ, Lllll, Fffff, Ww, Ss/`

#### Command Group Description:

This command controls the amplitude jitter function.

#### Command Definitions:

**Llll** - controls the amplitude jitter level in units of 0.024% (100% modulation/4096). Range is 0 to 4014 (0.0 to 98.0%AM). Default is 0.

**Ffff** - controls the amplitude jitter frequency in 0.1 Hz steps. Range is 0 to 3000 (0.0 Hz to 300.0 Hz). This command is invalid when the amplitude jitter waveform is noise. Default is 600 (60.0 Hz).

**Ww** - controls the amplitude jitter modulation waveform:

- 0 = sine
  - 1 = full-wave rectified sine
  - 2 = half-wave rectified sine
  - 3 = 300 Hz bandlimited noise
- Default is 0 (sine).

**Ss** - controls amplitude jitter on (1) or off (0). Default is 0 (off).

#### Response Formats:

`/C/`  
or  
`/AJ09, Eeee/`

<p><b>NOTE:</b> For units equipped for bidirectional impairment simulation, see <code>/AD,Ii/</code>. Amplitude Jitter is disabled for ETSI-2 Test Channel Configuration, see <code>/AD,Tt/</code> command.</p>
---

### 3.6.3. Audio Processor (CAP) Module Control

#### Command Format:

*/AP, Lp1111, Sds, Tdm, Xms, Yms/*

#### Command Group Description:

This command group controls the TAS Series II CAP module.

<b>NOTE:</b> The <i>/AD,li/</i> command does not effect the <i>/AP/</i> command group.
--

#### Command Definitions:

**Lp1111** - sets the programmable gain control specified by *p* to level specified by *1111*.

'*p*' specifies which gain element to control:

A = A→B compression input gain control (0dB to -40dB)  
{default to -12dB}

B = A→B expansion input gain control (0dB to -40dB)  
{default to -12dB}

C = B→A compression output gain control (+30dB to -10dB)  
{default to +14dB}

D = B→A expansion output gain control (+30dB to -10dB)  
{default to +14dB}

'*1111*' specifies the level control setting:

*1111* = gain to set in increments of .1dB

**Sds** - enables or disables the CAP function for each direction.

'*d*' specifies which direction to control:

A = A→B direction

B = B→A direction

'*s*' specifies the state of the CAP enable:

0 = disable (default)

1 = enable

**Tdm** - selects the test topology for each direction

‘d’ specifies which direction to control:

A = A→B direction

B = B→A direction

‘m’ specifies the test topology:

0 = GT Cellular topology (default)

1 = Tandem topology

2 = reserved for future use

**Xms** - controls the enable/disable state of specific CAP sub-modules (functions) in the A→B direction.

‘m’ specifies which function to control:

0 = Compressor & Expander

1 = Preemphasis & Deviation Limiter

2 = Deemphasis

‘s’ specifies the sub-module status:

0 = disable the specified sub-module

1 = enable the specified sub-module

(default is all sub-modules enabled)

**Yms** - controls the enable/disable state of specific CAP sub-modules (functions) in the for the B→A direction.

‘m’ specifies which sub-module to control:

0 = Compressor & Expander

1 = Preemphasis & Deviation Limiter

2 = Deemphasis

‘s’ specifies the sub-module status:

0 = disable the specified sub-module

1 = enable the specified sub-module

(default is all sub-modules enabled)

**Response Formats:**

/C/ or /AP, Eeee/

### 3.6.4. Auxiliary (Intermediate Talker or Listener) Echo 1 EIA/CCITT and ETSI-1 Test Channel Configuration

#### Command Format:

```
/AXE1, Ddddd, Llll, Tt, Ss/
```

#### Command Group Description:

Controls the auxiliary echo (intermediate talker or listener echo) function for EIA/CCITT and ETSI-1 Test Channel Configurations (see /AD,Tt/).

#### Command Definitions:

**Ddddd** - controls the auxiliary echo time delay in 0.125 msec. steps for the selected station interface. Range of "dddd" is 0 to 7000 (0 to 875.0 msec.). Default is 160 (approx. 20 msec.).

**L<+/->lll** - controls the auxiliary echo level in 0.1 dB steps for the selected station interface. Range of "lll" is 0 to 400 (0 to 40.0 dB attenuation for listener echo or 0 to 40.0 dB below signal level for intermediate talker echo). Default is 200 (20.0 dB).

**Tt** - selects intermediate talker (0) or listener (1) echo (type) for the selected station interface. Default is 0 (intermediate talker echo).

**Ss** - enables (1) or disables (0) auxiliary echo for the selected station interface. Default is 0 (disabled).

#### Response Formats:

```
/C/  
or  
/AXE1, Eeee/
```

**NOTE:** For units equipped for bidirectional impairment simulation see /AD,li/. AXE1 features are disabled for ETSI-2 Test Channel Configuration, see /AD,Tt/ command. For ETSI-2 Test Channel Configuration channel interruptions controls, see AXE2 commands.

### 3.6.5. Auxiliary (Intermediate Talker or Listener) Echo 2 ETSI-2 Test Channel Configuration

#### Command Format:

/AXE2, Ddddd, Llll, Tt, Ss/

#### Command Group Description:

Controls the auxiliary echo (intermediate talker or listener echo) function for ETSI-2 Test Channel Configuration (see /AD,Tt/).

#### Command Definitions:

**Ddddd** - controls the auxiliary echo time delay in 0.125 msec. steps for the selected station interface. Range is 0 to 2320 (0 to 290.0 msec.). Default is 160 (approx. 20 msec.).

**L<+/->lll** - controls the auxiliary echo level in 0.1 dB steps for the selected station interface. Range of "lll" is 0 to 400 (0 to 40.0 dB attenuation for listener echo or 0 to 40.0 dB below signal level for intermediate talker echo). Default is 200 (20.0 dB).

**Tt** - selects intermediate talker (0) or listener (1) echo (type) for the selected station interface. Default is 0 (intermediate talker echo).

**Ss** - enables (1) or disables (0) auxiliary echo for the selected station interface. Default is 0 (disabled).

#### Response Formats:

/C/  
or  
/AXE2, Eeee/

<p><b>NOTE:</b> For units equipped for bidirectional impairment simulation see /AD,li/. AXE2 features are disabled for EIA/CCITT and ETSI-1 Test Channel Configurations, see /AD,Tt/ command. For EIA/CCITT and ETSI-1 Test Channel Configurations channel interruptions controls, see MIC1 commands.</p>
---



### 3.6.6. Echo Control (Near & Far)

#### Command Format:

```
/EC, Lj<+/->lll, Pjp, Ss/
```

#### Command Group Description:

Controls the near and far echo attenuators for all Test Channel Configurations.

#### Command Definitions:

**Lj<+/->lll** - controls one of four echo attenuators. 'j' selects the echo attenuator:

- A - Station A Near End Echo Attenuator
- B - Station A Far End Echo Attenuator
- C - Station B Near End Echo Attenuator
- D - Station B Far End Echo Attenuator

'lll' determines the echo attenuator setting in 0.1 dB steps. Range is -100 to +400 (10.0 dB echo **gain** to 40 dB echo attenuation. Default for 'lll' is 210 (21.0 dB attenuation).

**Pjp** - Controls echo attenuator path polarity. 'j' selects the echo attenuator path:

- A - Station A Near End Echo Attenuator path
- B - Station A Far End Echo Attenuator path
- C - Station B Near End Echo Attenuator path
- D - Station B Far End Echo Attenuator path

p=0 makes the echo path non-inverting. p=1 inverts the echo path signal. Default for 'p' is 0 (non-inverting).

**Ss** - Enables all echo attenuators at the current attenuator settings (s=1) or disables (sets to maximum attenuation) all echo attenuators (s=0). Default is 0 (disabled).

#### Response Formats:

```
/C/  
or  
/EC30, Eeee/
```

### 3.6.7. Extended PCM/ADPCM Module Control

#### Command Format:

```

      /EP, Cjc, Qjq, Mm, Pp, I<->iii,
O<->l1l1, Tttttt, Ut, Br, G, Rd, Ee, Ss, Ll/

```

#### Command Group Description:

This controls the Extended PCM/ADPCM Links simulation module.

For units equipped for bidirectional impairment simulation, see /AD,Ii/.

#### Command Definitions:

European PCM/ADPCM Standard Link refers to the custom ECI ADPCM coding algorithm found on Transatlantic lines. Asian PCM/ADPCM Standard Link refers to the custom OKI ADPCM coding algorithm found on Transpacific lines.

**Cjc** - selects the coding for the specified link. Coding optimizes the dynamic range of the analog data sample. Your choices for coding are A-law and mu-law, which compress approximately 13 bits of dynamic range into 8 bits. Mu-law is the companding characteristic adopted by the U.S. and Japan, while A-law is the companding characteristic recommended by CCITT.

'j' specifies the link:

- 1 = Link 1, European PCM/ADPCM Standard Link
- 2 = Link 2, Asian PCM/ADPCM Standard Link

'c' specifies the coding:

- c = 0 selects no coding (analog bypass)
- c = 1 selects a-law PCM
- c = 2 selects mu-law PCM
- Default is 0 (no coding)

**Qjq** - selects the PCM rate (quantization) for the specified link.

'j' specifies the link:

- j = 1 - Link 1, European PCM/ADPCM Standard Link
- j = 2 - Link 2, Asian PCM/ADPCM Standard Link

'q' selects the rate:

- q = 0 selects 64 kbps
- q = 1 selects 32 kbps
- q = 2 selects 24 kbps (only the Asian Link supports this rate)
- Default is 0 (64 kbps)

**Mm** - configures the position of the Digital Channel with respect to the Analog Channel. You can position the Digital Channel in one of two locations along the signal path. (see /PC,Mm/)

'm' selects the location:

- m = 0, positions the Digital Channel before the Analog Channel
- m = 1, positions the Digital Channel after the Analog Channel
- Default is 1 (Digital Channel after the Analog Channel)

**Pp** - configures the position of the Series II PAL module in the Digital Impairment Channel. You may position the Series IIPAL module before or after the European/Asian PCM/ADPCM Links.

'p' selects the location:

- p = 0, positions the 1200 PAL before the EPAL PCM/ADPCM Links
- p = 1, positions the 1200 PAL after the EPAL PCM/ADPCM Links
- Default is 1 (1200 PAL module after the EPAL PCM/ADPCM Links)

**I<->iii** - sets the Digital Channel Input Gain. The input may be amplified by as much as 23dB or as little as -7dB. iii specifies the input level gain with a resolution of .1dB. i.e. 70(7dB of gain) to -230(23dB of loss) The default is 0dB.

**O<->III** - sets the Digital Channel Output Gain. The output may be amplified by as much as 7dB or attenuated by as much as 23dB. III specifies the output signal level gain with a resolution of .1dB. i.e. 70(7dB of gain) to -230(23dB of loss) The default is 0dB.

**Tttttt** - sets the frame slip interarrival time. ttttt specifies the average time between frame slips (interarrival time of a Poisson process in Pseudo Random mode). The time is specified in increments of .1 seconds ( $1 \leq ttttt \leq 32767$ ). The default frame slip interarrival time is ttttt=600 (60 seconds).

**Ut** - specifies the type of time period between frame slips.

't' specifies the time period type.

- 0 = uniform period
- 1 = pseudo-random period
- Default is 0 (uniform period)

**Br** - specifies the repetition of frame slips in any one direction. A value of 1 indicates frame slips will toggle back and forth (from positive to negative). A value of 15 here (15 is the maximum value) indicates that slips will repeat in one direction for 15 times before switching to the next direction.

'r' specifies the number of repetitive slips. The default value for the buffer size is 1.

**G** - this triggers a single frame slip immediately independent of the switch /EP,Ss/ (G->go!). This command has no parameters.

**Rd** - this command resets the frame slip buffer and sets a direction for the next frame slip. If a connection is active when this command is sent, this command will induce a large frame slip (a slip of multiple frames) while the buffer is either filled or purged.

'd' specifies the direction for the next frame slip:  
0 = negative slips will follow  
1 = positive slips will follow  
Default is 0 (negative frame slips will follow)

**Ee** - defines the frame slip buffer to be either exhaustive (runs until the buffer empties or fills), or cyclic (runs forever).

'e' is defined as follows:  
0 = exhaustive buffer  
1 = cyclic buffer  
Default is 1 (cyclic buffer)

**Ss** - Frame Slip Switch - this turns on or off frame slips.

's' is defined as follows:  
0 = off  
1 = on  
Default is 0 (frame slips off)

**Ll** - specify which link will get the frame slips into its PCM stream

'l' is defined as follows:  
1 = Link 1, European PCM/ADPCM Standard Link  
2 = Link 2, Asian PCM/ADPCM Standard Link  
Default is 1 (European Link)

**Response Formats:**

/C/  
or  
/EP31, Eeee/

### 3.6.8. Frequency Shift

#### Command Format:

`/FS, F<+/->ffff, Mm, Ss/`

#### Command Group Description:

This controls the frequency offset function.

#### Command Definitions:

**F<+/->ffff** - up to four decimal digits and a sign digit control the magnitude of offset. In Mode 0 (M0), the offset is programmed in 0.005 Hz steps with a range of -1999 to 1999 (-9.995 Hz to +9.995 Hz). In Mode 1 (M1), the offset is programmed in 0.1 Hz steps with a range of -1999 to 1999 (-199.9 Hz to +199.9 Hz). Default is 0.

**Mm** - controls the mode:

0 = 0.005 Hz resolution from -9.995 Hz to 9.995 Hz

1 = 0.1 Hz resolution from -199.9 Hz to 199.9 Hz

Default is 0 (0.005 Hz resolution)

**Ss** - one digit controls frequency offset on (1) or off (0). Default is 0.

#### Response Formats:

`/C/`

or

`/FS02, Eeee/`

**NOTE:** For units equipped for bidirectional impairment simulation, see `/AD,li/` command. Frequency Shift is disabled for ETSI-2 Test Channel Configuration, see `/AD,Tt/` command.

### 3.6.9. Gain/Delay

#### Command Format:

/GD, Www, Xxx, Yyy, Zzz, Mm/

#### Command Group Description:

This controls the gain versus frequency, and envelope delay versus frequency functions. The four filters listed below are connected in series, so the overall gain and delay response is the concatenation of the four selected responses. The gain filters are designed to introduce no delay distortion (linear phase), and the delay filters are designed to introduce no gain distortion (all-pass).

**NOTE:** For units equipped for bidirectional impairment simulation, see /AD,I/. Gain and Delay Filters are disabled for ETSI-2 Test Channel Configuration, see /AD,Tt/ command.

#### Command Definitions:

**Www** - controls gain filter #2. ww selects gain versus frequency function, as follows:

- 00 = flat
- 01 = low frequency gain slope characteristic #1
- 02 = low frequency gain slope characteristic #2
- 03 = low frequency gain slope characteristic #3
- 04 = low frequency gain slope characteristic #4
- 05 = low frequency gain slope characteristic #5
- 06 = low frequency gain slope characteristic #6
- 07 = low frequency gain slope characteristic #7
- 08 = SEG 3002 gain characteristic emulation (Seg FA-1445)
- 09 = worst case Bell 3002 (C0) gain characteristic
- 10 = worst case Bell C1 gain characteristic
- 11 = worst case Bell C2 gain characteristic
- 12 = worst case Bell C4 gain characteristic
- 13 = worst case CCITT M1020 gain characteristic
- 14 = worst case CCITT M1025 gain characteristic
- 15 = worst case CCITT M1040 gain characteristic

/AD,S03=00/ for enhanced filters:

- 16 - EIA "A" enhanced standard gain characteristic for modem testing
- 17 - EIA "B" enhanced standard gain characteristic for modem testing
- 18 - EIA "C" enhanced standard gain characteristic for modem testing

/AD,S03=01/ for TAS 1010 compatible filters:

- 16 - EIA "A" standard gain characteristic for modem testing
- 17 - EIA "B" standard gain characteristic for modem testing
- 18 - EIA "C" standard gain characteristic for modem testing
- 19 = high frequency gain slope characteristic #1
- 20 = high frequency gain slope characteristic #2
- 21 = high frequency gain slope characteristic #3
- 22 = high frequency gain slope characteristic #4
- 23 = high frequency gain slope characteristic #5
- 24 = high frequency gain slope characteristic #6
- 25 = high frequency gain slope characteristic #7
- 26 = CCITT cable - 1 gain characteristic
- 27 = CCITT cable - 2 gain characteristic
- 28 = CCITT cable - 3 gain characteristic
- 29 through 32 = reserved
- 33 = CONUS mid data gain characteristic
- 34 = CONUS mid voice gain characteristic
- 35 = CONUS poor data gain characteristic
- 36 = CONUS poor voice gain characteristic
- 37 = European mid data gain characteristic
- 38 = European mid voice gain characteristic
- 39 = European poor voice gain characteristic
- 40 = NSB gain characteristic
- 41 = NTB gain characteristic
- 42 = European poor data gain characteristic
- 43 = Japanese (JPN) link 1 gain characteristic
- 44 = Japanese (JPN) link 2 gain characteristic
- 45 = Japanese (JPN) link 3 gain characteristic
- 46 = Japanese (JPN) link 4 gain characteristic
- 47 = Japanese (JPN) link 5 gain characteristic
- 48 = Japanese (JPN) link 6 gain characteristic
- 49 = Japanese (JPN) link 7 gain characteristic
- 50 = Japanese 4 dB local loop gain characteristic
- 51 = Japanese 8 dB local loop gain characteristic
- 52 = Japanese 12 dB local loop gain characteristic
- 53 = CCITT R28 gain characteristic

54 = French line 1 gain characteristic  
55 = French line 2 gain characteristic  
56 = French line 3 gain characteristic  
57 = French line 4 gain characteristic  
58 = NET 20 Test Channel 1 gain characteristic  
59 = RITT (China) gain characteristic  
60 = TR 50150 ("True Voice") gain characteristic  
61 = ASIA1 gain characteristic  
62 = ASIA 2 gain characteristic  
Default is 00 (flat)

**Xxx** - controls gain filter #1. xx selects gain versus. frequency function, as follows:

00 = flat  
01 = high frequency gain slope characteristic #1  
02 = high frequency gain slope characteristic #2  
03 = high frequency gain slope characteristic #3  
04 = high frequency gain slope characteristic #4  
05 = high frequency gain slope characteristic #5  
06 = high frequency gain slope characteristic #6  
07 = high frequency gain slope characteristic #7  
08 = SEG 3002 gain characteristic emulation. (Seg FA-1445)  
09 = worst case Bell 3002 (C0) gain characteristic  
10 = worst case Bell C1 gain characteristic  
11 = worst case Bell C2 gain characteristic  
12 = worst case Bell C4 gain characteristic  
13 = worst case CCITT M1020 gain characteristic  
14 = worst case CCITT M1025 gain characteristic  
15 = worst case CCITT M1040 gain characteristic

/AD,S03=00/ for enhanced filters:

16 - EIA "A" enhanced standard gain characteristic for modem testing  
17 - EIA "B" enhanced standard gain characteristic for modem testing  
18 - EIA "C" enhanced standard gain characteristic for modem testing

/AD,S03=01/ for TAS 1010 compatible filters:

16 - EIA "A" standard gain characteristic for modem testing  
17 - EIA "B" standard gain characteristic for modem testing  
18 - EIA "C" standard gain characteristic for modem testing  
19 = low frequency gain slope characteristic #1  
20 = low frequency gain slope characteristic #2



21 = low frequency gain slope characteristic #3  
22 = low frequency gain slope characteristic #4  
23 = low frequency gain slope characteristic #5  
24 = low frequency gain slope characteristic #6  
25 = low frequency gain slope characteristic #7  
26 = CCITT cable - 1 gain characteristic  
27 = CCITT cable - 2 gain characteristic  
28 = CCITT cable - 3 gain characteristic  
29 through 32 = reserved  
33 = CONUS mid data gain characteristic  
34 = CONUS mid voice gain characteristic  
35 = CONUS poor data gain characteristic  
36 = CONUS poor voice gain characteristic  
37 = European mid data gain characteristic  
38 = European mid voice gain characteristic  
39 = European poor voice gain characteristic  
40 = NSB gain characteristic  
41 = NTB gain characteristic  
42 = European poor data gain characteristic  
43 = Japanese (JPN) link 1 gain characteristic  
44 = Japanese (JPN) link 2 gain characteristic  
45 = Japanese (JPN) link 3 gain characteristic  
46 = Japanese (JPN) link 4 gain characteristic  
47 = Japanese (JPN) link 5 gain characteristic  
48 = Japanese (JPN) link 6 gain characteristic  
49 = Japanese (JPN) link 7 gain characteristic  
50 = Japanese 4 dB local loop gain characteristic  
51 = Japanese 8 dB local loop gain characteristic  
52 = Japanese 12 dB local loop gain characteristic  
53 = CCITT R28 gain characteristic  
54 = French line 1 gain characteristic  
55 = French line 2 gain characteristic  
56 = French line 3 gain characteristic  
57 = French line 4 gain characteristic  
58 = NET 20 Test Channel 1 gain characteristic  
59 = RITT (China) gain characteristic  
60 = TR 50150 ("True Voice") gain characteristic  
61 = ASIA1 gain characteristic  
62 = ASIA 2 gain characteristic  
Default is 00 (flat)

**Yyy** - controls group delay filter #2. yy selects the group delay versus frequency function as follows:

- 00 = no filter
- 01 = low frequency delay slope characteristic #1
- 02 = low frequency delay slope characteristic #2
- 03 = low frequency delay slope characteristic #3
- 04 = low frequency delay slope characteristic #4
- 05 = low frequency delay slope characteristic #5
- 06 = low frequency delay slope characteristic #6
- 07 = low frequency delay slope characteristic #7
- 08 = SEG 3002 group delay characteristic emulation. (Seg FA-1445)
- 09 = worst case Bell 3002 (C0) group delay characteristic
- 10 = worst case Bell C1 group delay characteristic
- 11 = worst case Bell C2 group delay characteristic
- 12 = worst case Bell C4 group delay characteristic
- 13 = worst case CCITT M1020 group delay characteristic
- 14 = worst case CCITT M1025 group delay characteristic

/AD,S03=00/ for enhanced filters:

- 15 - EIA "1" enhanced standard group delay characteristic for modem testing
- 16 - EIA "2" enhanced standard group delay characteristic for modem testing
- 17 - EIA "3" enhanced standard group delay characteristic for modem testing
- 18 - EIA "4" enhanced standard group delay characteristic for modem testing
- 19 - EIA "5" enhanced standard group delay characteristic for modem testing

/AD,S03=01/ for TAS 1010 compatible filters:

- 15 - EIA "1" standard group delay characteristic for modem testing
- 16 - EIA "2" standard group delay characteristic for modem testing
- 17 - EIA "3" standard group delay characteristic for modem testing
- 18 - EIA "4" standard group delay characteristic for modem testing
- 19 - EIA "5" standard group delay characteristic for modem testing
- 20 = high frequency delay slope characteristic #1
- 21 = high frequency delay slope characteristic #2
- 22 = high frequency delay slope characteristic #3
- 23 = high frequency delay slope characteristic #4
- 24 = high frequency delay slope characteristic #5
- 25 = high frequency delay slope characteristic #6
- 26 = high frequency delay slope characteristic #7
- 27 through 32 = reserved
- 33 = CONUS mid data delay characteristic
- 34 = CONUS mid voice delay characteristic
- 35 = CONUS poor data delay characteristic

36 = CONUS poor voice delay characteristic  
 37 = European mid data delay characteristic  
 38 = European mid voice delay characteristic  
 39 = European poor voice delay characteristic  
 40 = NSB delay characteristic  
 41 = NTB delay characteristic  
 42 = European poor data delay characteristic  
 43 = Japanese (JPN) link 1 delay characteristic  
 44 = Japanese (JPN) link 2 delay characteristic  
 45 = Japanese (JPN) link 3 delay characteristic  
 46 = Japanese (JPN) link 4 delay characteristic  
 47 = Japanese (JPN) link 5 delay characteristic  
 48 = Japanese (JPN) link 6 delay characteristic  
 49 = Japanese (JPN) link 7 delay characteristic  
 50 = CCITT R28 delay characteristic  
 51 = French line 1 delay characteristic  
 52 = French line 2 delay characteristic  
 53 = French line 3 delay characteristic  
 54 = French line 4 delay characteristic  
 55 = NET 20 Test Channel 1 delay characteristic  
 56 = RITT 1 (China) delay characteristic  
 57 = RITT 2 (China) delay characteristic  
 58 = Asia 1 delay characteristic  
 59 = Asia 2 delay characteristic  
 Default is 00 (flat)

**Zzz** - controls group delay filter #1. zz selects group delay versus frequency function, as follows:

00 = no filter  
 01 = high frequency delay slope characteristic #1  
 02 = high frequency delay slope characteristic #2  
 03 = high frequency delay slope characteristic #3  
 04 = high frequency delay slope characteristic #4  
 05 = high frequency delay slope characteristic #5  
 06 = high frequency delay slope characteristic #6  
 07 = high frequency delay slope characteristic #7  
 08 = SEG 3002 group delay characteristic emulation. (Seg FA-1445)  
 09 = worst case Bell 3002 (C0) group delay characteristic  
 10 = worst case Bell C1 group delay characteristic  
 11 = worst case Bell C2 group delay characteristic  
 12 = worst case Bell C4 group delay characteristic

13 = worst case CCITT M1020 group delay characteristic

14 = worst case CCITT M1025 group delay characteristic

/AD,S03=00/ for enhanced filters:

15 - EIA "1" enhanced standard group delay characteristic for modem testing

16 - EIA "2" enhanced standard group delay characteristic for modem testing

17 - EIA "3" enhanced standard group delay characteristic for modem testing

18 - EIA "4" enhanced standard group delay characteristic for modem testing

19 - EIA "5" enhanced standard group delay characteristic for modem testing

/AD,S03=01/ for TAS 1010 compatible filters:

15 - EIA "1" standard group delay characteristic for modem testing

16 - EIA "2" standard group delay characteristic for modem testing

17 - EIA "3" standard group delay characteristic for modem testing

18 - EIA "4" standard group delay characteristic for modem testing

19 - EIA "5" standard group delay characteristic for modem testing

20 = low frequency delay slope characteristic #1

21 = low frequency delay slope characteristic #2

22 = low frequency delay slope characteristic #3

23 = low frequency delay slope characteristic #4

24 = low frequency delay slope characteristic #5

25 = low frequency delay slope characteristic #6

26 = low frequency delay slope characteristic #7

27 through 32 = reserved

33 = CONUS mid data delay characteristic

34 = CONUS mid voice delay characteristic

35 = CONUS poor data delay characteristic

36 = CONUS poor voice delay characteristic

37 = European mid data delay characteristic

38 = European mid voice delay characteristic

39 = European poor voice delay characteristic

40 = NSB delay characteristic

41 = NTB delay characteristic

42 = European poor data delay characteristic

43 = Japanese (JPN) link 1 delay characteristic

44 = Japanese (JPN) link 2 delay characteristic

45 = Japanese (JPN) link 3 delay characteristic

46 = Japanese (JPN) link 4 delay characteristic

47 = Japanese (JPN) link 5 delay characteristic

48 = Japanese (JPN) link 6 delay characteristic

49 = Japanese (JPN) link 7 delay characteristic

50 = CCITT R28 delay characteristic  
51 = French line 1 delay characteristic  
52 = French line 2 delay characteristic  
53 = French line 3 delay characteristic  
54 = French line 4 delay characteristic  
55 = NET 20 Test Channel 1 delay characteristic  
56 = RITT 1 (China) delay characteristic  
57 = RITT 2 (China) delay characteristic  
58 = Asia 1 delay characteristic  
59 = Asia 2 delay characteristic  
Default is 00 (no filter)

**Mm** - has no effect in Series II systems. It was used to control automatic recalibration in 1010 systems equipped with 1010-4 modules (basic gain/delay).

**Response Formats:**

/C/  
or  
/GD17, Eeee/

### 3.6.10. Gain Hits

#### Command Format:

/GH,L<+/->lll,Rrrrr,Dddddd,Iiiii,Mm,[Ss or T]/

#### Command Group Description:

This controls the network emulator gain hits function.

#### Command Definitions:

**L<+/->lll** - controls the gain hit level in units of 0.1 dB. Range is -200 to +60 (-20.0 dB to +6.0 dB). Default is 30 (+3.0 dB).

**Rrrrr** - controls the gain hit risetime in units of 0.1 msec. Range is 2 to 9900 (0.2 msec to 990.0 msec). Default is 2 (0.2 msec)

**Dddddd** - controls the gain hit duration in units of 0.625 msec. Duration (D) must be greater than risetime (R). Range is 3 to 32000 (1.875 msec to 20000 msec). Default is 8 (5.0 msec).

**Iiiii** - controls the interval between periodic gain hits in units of 0.01 sec. Interval must be greater than duration + risetime. Range is 10 to 32000 (0.1 sec to 320.0 sec). Default is 100 (1.0 sec).

**NOTE:** The least significant digit of the programmed setting has no effect on the interval time.

**Mm** - provides pseudorandom (1) or regular (0) gain hit arrival time (trigger) mode. Default is 0 (regular).

**Ss** - controls gain hits on (1) or off (0). Default is 0 (off).

**T** - triggers a single gain hit. Note that this command contains no parameter.

#### Response Formats:

/C/  
or  
/GH07,Eeee/

**NOTE:** For units equipped for bidirectional impairment simulation, see /AD,Ii/. Gain Hits is disabled for ETSI-2 Test Channel Configuration, see /AD,Tt/ command.

### 3.6.11. Impulse Noise (IEEE)

#### Command Format:

```
/IMP1,L1111,Iiiii,Ww,Mm,Pppp,[Ss or T]/
```

#### Command Description:

This controls the IEEE impulse noise function.

#### Command Descriptions:

**L1111** - controls the impulse noise level for IEEE Standard impulses:

Level in units of 0.1 dB

Range is 200 to 1000 (20.0 dB<sub>rn</sub> to 100.0 dB<sub>rn</sub>)

Default is 340 ( 34.0 dB<sub>rn</sub> )

**Iiiii** - controls the interval between impulse hits for IEEE Standard impulses:

Interval is in units of 10 msec

Range is 10 to 32000 (0.1 sec to 320.0 sec)

Default is 100 (1.0 sec)

**Ww** - controls impulse output level correction for various instrument measuring filters:

0 = c-notch

Default is 0 (c-notch)

**Mm** - controls impulse arrival time (trigger) mode:

0 = regular internal trigger

1 = pseudorandom internal trigger

2 = regular external trigger (pause/impulse sequence is started on the falling edge of each external trigger pulse)

3 = single shot external trigger (once armed by the /IMP1,T/, a single pause/impulse sequence is started on the next falling edge of the external trigger pulse). /IMP1,Ss/ has no effect on this mode

Default is 0 (regular)

**Pppp** - controls the pause (time delay from the occurrence of an external trigger to the start of an impulse). Pause is in units of 0.125 msec. Range is 0 to 800 (0.0 to 100.0 msec). Default is 0 (0.0 msec)

**Ss** - controls impulse noise on (1) or off (0). Default is 0 (off).

**T** - generates a single internal impulse trigger or arms a single shot external trigger (see /IMP1,M3/). Note that this command contains no parameter.

**Response Formats:**

/C/  
or  
/IMP1, Eeee/

**NOTE:** For units equipped for bidirectional impairment simulation, see /AD,li/ command. IEEE Impulse Noise commands will be accepted and stored internally at any time, however to enable IEEE impulses the /AD,S01=0/ command must be configured.



### 3.6.12. Impulse Noise (Bipolar)

#### Command Format:

```
/IMP2,L<+/->l111,Iiiii,Ddd,Mm,Pppp,[Ss or T]/
```

#### Command Group Description:

This controls the Bipolar impulse noise function.

#### Command Descriptions:

**L<+/->l111** - controls the bipolar impulse noise level:

Level in units of 0.1 dBm

Range is -500 to +100 (-50.0 dBm to +10.0 dBm)

Default is -250 (-25.0 dBm)

**Iiiii** - controls the interval between impulse hits for bipolar impulses:

Interval in units of 1.0 msec

Range is 1 to 60000 (1 msec to 60000 msec)

Default is 100 (100 msec)

**Ddd** - controls the pulse duration for bipolar pulses in units of 0.125 msec. Range is 1 to 80 (0.125 msec to 10.0 msec). Default is 2 (0.250 msec).

**Mm** - controls impulse arrival time (trigger) mode:

0 = regular internal trigger

1 = pseudorandom internal trigger

2 = regular external trigger (pause/impulse sequence is started on the falling edge of each external trigger pulse)

3 = single shot external trigger (once armed by the /IMP2,T/, a single pause/impulse sequence is started on the next falling edge of the external trigger pulse). /IMP2,Ss/ has no effect on this mode

Default is 0 (regular)

**Pppp** - controls the pause (time delay from the occurrence of an external trigger to the start of an impulse). Pause is in units of 0.125 msec. Range is 0 to 800 (0 to 100 msec). Default is 0 (0 msec)

**Ss** - controls impulse noise on (1) or off (0). Default is 0 (off).

**T** - generates a single internal impulse trigger or arms a single shot external trigger (see /IMP2,M3/). Note that this command contains no parameter.

**Response Formats:**

/C/  
or  
/IMP2, Eeee/

**NOTE:** For units equipped for bidirectional impairment simulation, see /AD,li/ command. Bipolar Impulse Noise commands will be accepted and stored internally at any time, however to enable Bipolar impulses the /AD,S01=1/ command must be configured.

### 3.6.13. Impairment Generator I/O

#### Command Format:

```
/IO,Aa,C,Dd,Ee,Ff,Gg,I-iii,IR,L<->lll,Lr,Mm,Nn,R<->rrr,RR,ss,T-ttt,TR,Vvv,Z/
```

#### Command Group Description:

This controls the input/output configuration for the TAS Series II network simulator impairment generators.

#### Command Definitions:

**Aa** - causes impairment generator 1 to perform an AGC operation. If a=0, the impairment generator performs an INPUT AGC. If a=1, the impairment generator performs an INPUT AGC, followed by an OUTPUT AGC. If no parameter is appended to the A, the network simulator performs an INPUT AGC.

**C** - forces the simulator to perform a self-calibration and diagnosis. This operation takes approximately 50 seconds. All network simulator setup information is lost. The network simulator assumes the default (power-up) parameter settings and resets all signal processing modules. Note that this command contains no parameter.

**Dd** - selects the A→B monitor signal (see /IO,Ee/) if d = 0, or the B→A monitor signal (see /IO,Ff/) if d = 1 as the input to the audio monitor. Default is 0.

**Ee** - controls the signal monitor selection for display of a signal at the scope output port (A→B). It also controls the signal selection for the audio monitor (see /IO,Dd/). Selections for e are defined as follows:

- 0 = Station A Transmit
- 1 = Station B Receive 4 Wire
- 2 = Station B Receive 2 Wire
- Default is 0 (Station A Transmit)

**Ff** - controls the signal monitor selection for display of a signal at the scope output port (B→A). It also controls the signal selection for the audio monitor (see /IO,Dd/). Selections for f are defined as follows:

- 0 = Station B Transmit
- 1 = Station A Receive 4 Wire
- 2 = Station A Receive 2 Wire
- Default is 0 (Station B Transmit)

**Gg** - causes impairment generator 2 to perform an AGC operation. If g=0, the impairment generator performs an INPUT AGC. If g=1, the impairment generator

performs an INPUT AGC, followed by an OUTPUT AGC. If no parameter is appended to the G, the network simulator performs an INPUT AGC.

**I<->iii** - input level control for the A→B transmission channel in units of 0.1 dBm. This command may be used instead of the AGC when the input signal level is known. The range of 'iii' is 0 to -230 (0 to -23.0 dBm). Default is -100 (-10.0 dBm). Since 'iii' is negative (except for a level of 0 dBm), the input level control provides gain to the input transmission channel signal.

**IR** - input level control readback for A→B transmission channel. A response of a negative number indicates GAIN of the transmission channel signal level by the input level control, and a response of a positive number indicates attenuation by the input level control. This command responds with /IO12,IR<+/->rrr/ where +70 (+7.0 dBm) <= 'rrr' <= -230 (-23.0 dBm). If this command is used after an input AGC, the value reported is the input transmission channel signal level (in units of 0.1 dBm) of the A→B channel input signal.

For example: the Series II responds with /IO12,IR-100/, which means the input transmission channel signal receives 10.0 dB of gain from the input level control feature.

The input level control feature adjusts the input signal level to allow optimum processing of the signal and impairments within the Series II.

**L<->III** - analog channel output gain for the A→B transmission channel in units of 0.1 dBm. The range of 'III' is 0 to -500 (0 to -50.0 dBm). Default is -180 (-18.0 dBm). Since 'III' is negative (except for a level of 0 dBm), the analog channel output gain provides attenuation to the output transmission channel signal.

**LR** - analog output level gain readback for A→B transmission channel. A response of a negative number indicates ATTENUATION of the transmission channel signal level by the analog output level gain, and a response of a positive number indicates gain by the output level control. This command responds with /IO12,LR<+/->rrr/ where 0 (0.0 dBm) <= 'rrr' <= -500 (-50.0 dBm). If this command is used after an output AGC, the value reported is the analog output transmission channel signal level (in units of 0.1 dBm) of the A→B analog channel output signal.

For Example: the Series II responds with /IO12,LR-180/, which means the output transmission channel signal receives 18.0 dB of attenuation from the output level control feature.

**Mm** - controls impairment generator 1 signal source. Choices are external (1) and internal (0). When internal is selected, impairment generator 1 input signal is supplied by the internal tone synthesizer. Default is 1 (external source).

**Nn** - controls the rate of impairment generator signal level adjustments for both input and output levels of A→B and B→A channels. 'n' selects the speed:

- 0 - single step (default)
- 1 - ramp

**R<->rrr** - input level control for the B→A transmission channel in units of 0.1 dBm. This command may be used instead of the AGC when the input signal level is known. The range of 'rrr' is 0 to -230 (0 to -23.0 dBm). Default is 0 (0.0 dBm). Since 'rrr' is negative (except for a level of 0 dBm), the input level control provides gain to the input transmission channel signal.

**RR** - input level control readback for B→A transmission channel. A response of a negative number indicates GAIN of the transmission channel signal level by the input level control, and a response of a positive number indicates attenuation by the input level control. This command responds with /IO12,RR<+/->rrr/ where +70 (+7.0 dBm) <= 'rrr' <= -230 (-23.0 dBm). If this command is used after an input AGC, the value reported is the input transmission channel signal level (in units of 0.1 dBm) of the B→A channel input signal.

For example: the Series II responds with /IO12,RR-50/, which means the input transmission channel signal receives 5.0 dB of gain from the input level control feature.

The input level control feature adjusts the input signal level to allow optimum processing of the signal and impairments within the Series II.

**Ss** - controls impairment generator 2 signal source. Choices are external (1) and internal (0). When internal is selected, impairment generator 2 input signal is supplied by the internal tone synthesizer. Default is 1 (external source).

**T<->ttt** - analog channel output gain for the B→A transmission channel in units of 0.1 dBm. The range of 'ttt' is 0 to -500 (0 to -50.0 dBm). Default is -130 (-13.0 dBm). Since 'ttt' is negative (except for a level of 0 dBm), the analog channel output gain provides attenuation to the analog channel output transmission channel signal.

**TR** - analog output level gain readback for B→A transmission channel. A response of a negative number indicates ATTENUATION of the transmission channel signal level by the analog channel output level gain, and a response of a positive number indicates gain by the analog output level gain. This command responds with /IO12,TR<+/->rrr/ where 0 (0.0 dBm) <= 'rrr' <= -500 (-50.0 dBm). If this command is used after an output AGC, the value reported is the analog output transmission channel signal gain (in units of 0.1 dBm) of the B→A analog channel output signal.

Example: the Series II responds with /IO12,TR-130/, which means the output transmission channel signal receives 13.0 dB of attenuation from the analog output level gain feature.

**Vvv** - controls the volume of the audio monitor. vv determines the volume in 16 steps. Range is 0 (off) to 15 (high). Default is 0.

**Z** - causes the network simulator to clear itself, i.e., establish the default (power-up) parameter settings. It maintains all calibration values and resets all signal processing and interface modules.

**Response Formats:**

```

/C/
or
/IO12,IR<+/->rrr/
or
/IO12,LR<+/->rrr/
or
/IO12,RR<+/->rrr/
or
/IO12,TR<+/->rrr/
or
/IO12,Eeee/

```

### 3.6.14. Line Control

#### Command Format:

*/LC, Aja, Bjb, Dd, Ee, Iji, Ljl, Mm, Ss, Vv, Xjx, Yjy/*

#### Command Group Description:

This controls the central office network simulator line configuration parameters.

#### Command Definitions:

**Aja** - controls station A and B external channel access to the transmit and receive ports.

This command is valid only for the Series II units that are equipped with the Channel Access Module Option.

'j' selects the port:

- A - station A transmit port
- B - station A receive port
- C - station B transmit port
- D - station B receive port

'a' controls the external access state of the selected port:

- 0 - external access disable (default)
- 1 - external access enable

**Bjb** - selects the internal or external hybrid balance network when in any 2-wire configuration.

'j' determines the hybrid balance impedance to be controlled:

- A = station A hybrid
- B = station B hybrid

'b' selects:

- 0 = internal 604-ohm impedance (default)
- 1 = externally supplied impedance

If the externally supplied impedance is selected, you must supply a balance network between the appropriate pins on the rear panel terminal strip.

**Dd** - sets reverse (d=1) or normal (d=0) channel mode. If reverse mode is set, the simulator places the attenuator in the A→B path, and places the impairments in the B→A path. Default is 0 (normal).

**Ee** - sets internal (e=0 - i.e. disabled) or external (e=1 - i.e. enabled) reverse channel mode. Default is 0 (internal).

**Iji** - controls the interface isolation for station A or B. 'j' selects the station:

A = station A

B = station B

'i' controls the isolation state of the selected station:

0 = off (i.e. inactive, or station not isolated, tip/ring connected to front/rear panel jacks)

1 = on (i.e. active, or station is isolated, tip/ring not connected to front/rear panel jacks)

Default is 0 (off or inactive).

**Ljl** - controls station A or B feed resistance for voltage source operation (see /LC,Ss/).

'j' selects the station:

A = station A

B = station B

'l' selects the loop resistance:

0 = low resistance (300 Ohms)

1 = high resistance (1400 Ohms)

Default is 1 (high resistance - 1400 Ohms)

**Mm** - selects the network configuration. Selections for 'm' are as follows:

0 = 4-wire private

1 = 2-wire switched

2 = 2-wire private

3 = 2-wire auto-switched

Default is 0 (4-wire private)

**Ss** - selects the internal current source (0) or voltage source (1) to supply loop current for switched mode operation. Default is 0 (current source)

**Vv** - selects the magnitude of the loop current generator battery. Selections are as follows:

0 = 45 volts

1 = 54 volts

Default is 0 (45 volts)



**Xjx** - controls station A or B loopback relay in 4 Wire configuration (Pins 3 and 6 on the modular jack are connected when the loopback relay is closed). 'j' selects the station:

A - station A

B - station B

'x' selects the relay state:

0 - open (active)

1 - closed (inactive) (default)

**Yjy** - controls station A or B program resistor relay (866 Ohms is between pins 7 and 8 on the modular jack when the relay is closed) when in 2-wire configuration.

'j' selects the station:

A - station A

B - station B

'y' selects the relay state:

0 - open (default)

1 - closed (866 Ohms)

**Response Formats:**

/C/

or

/LC23 , Eeee/

### 3.6.15. Channel Interruptions (Micro-Cutoff) 1 EIA/CCITT and ETSI-1 Test Channel Configurations

#### Command Format:

`/MIC1,Ddddd,Iiiii,[Ss or T]/`

#### Command Group Description:

Controls the channel interruptions function for EIA/CCITT and ETSI-1 Test Channel Configurations (see `/AD,Tt/`).

#### Command Definitions:

**Ddddd** - controls interruptions duration in units of 1 msec. Range is 1 to 20000 (1 msec. to 20000 msec.). Default is 10 (10 msec.).

**Iiiii** - controls the interval between periodic interruptions. Interval must be greater than Duration. Range is 10 to 32000 (0.1 sec. to 320.0 sec., 10 msec step size). Default is 100 (1.0 sec.).

**Ss** - controls interruptions "on" (1) or "off" (0). Default is 0 (off).

**T** - triggers a single interruption. Note that this command contains no parameter.

#### Response Formats:

`/C/`  
or  
`/MIC1,Eeee/`

<p><b>NOTE:</b> For units equipped for bidirectional impairment simulation see <code>/AD,Ii/</code>. MIC1 features are disabled for ETSI-2 Test Channel Configuration, see <code>/AD,Tt/</code> command. For ETSI-2 Test Channel Configuration channel interruptions controls, see MIC2 commands.</p>
---

### 3.6.16. Channel Interruptions (Micro-Cutoff) 2 ETSI-2 Test Channel Configuration

#### Command Format:

```
/MIC2,Ddddd,Iiiii,[Ss or T]/
```

#### Command Group Description:

Controls the channel interruptions function for ETSI-2 Test Channel Configuration (see /AD,Tt/).

#### Command Definitions:

**Ddddd** - controls interruptions duration in units of 1 msec. Range is 1 to 6600 (1 msec. to 6600 msec.). Default is 10 (10 msec.).

**Iiiii** - controls the interval between periodic interruptions. Interval must be greater than Duration. Range is 10 to 10600 (0.1 sec. to 106.0 sec., 10 msec step size). Default is 100 (1.0 sec.).

**Ss** - controls interruptions "on" (1) or "off" (0). Default is 0 (off).

**T** - triggers a single interruption. Note that this command contains no parameter.

#### Response Formats:

```
/C/  
or  
/MIC2,Eeee/
```

**NOTE:** For units equipped for bidirectional impairment simulation see /AD,Ii/. MIC2 features are disabled for EIA/CCITT and ETSI-1 Test Channel Configurations, see /AD,Tt/ command. For EIA/CCITT and ETSI-1 Test Channel Configuration channel interruptions controls, see MIC1 commands.

### 3.6.17. Signal Measurements

#### Command Format:

/MM, Rr/

#### Command Group Description:

This initiates a level and frequency measurement on the specified signal.

#### Command Definitions:

When the **R** command is selected without a parameter, the measure point will be selected in the same way as the identical TAS 1010 command. If the Series II is in Normal mode (/LC,D0/), the measurement will be taken at A transmit. If the Series II is in Reverse mode (/LC,D1/), the measurement will be taken at B transmit.

**Rr** - measures the level and frequency at the selected measurement point. The level measurement is true RMS, and is accurate to +/- 0.3 dB at the impairments generator input. The frequency measurement is valid for single frequency signals only, and is accurate to +/- 5 Hz.

The frequency measurement is invalid for signal levels less than -25 dBm.

Selections are defined as follows:

- 0 or no parameter = Station A transmit level and frequency
- 1 = Station B receive 4 wire level and frequency
- 2 = Station B receive 2 wire level and frequency
- 3 = Station B transmit level and frequency
- 4 = Station A receive 4 wire level and frequency
- 5 = Station A receive 2 wire level and frequency

#### Response Formats:

/MM13, L111, Fffff/

or

/MM13, Eeee/

#### Response Command Definitions:

**L<->III** - contains the measured signal input level in units of 0.1 dBm. It contains 999 if the input signal level is greater than +8 dBm, and contains -999 if the input signal level is less than -57 dBm.

**Fffff** - contains the measured signal input frequency in Hz.

### 3.6.18. Nonlinear Distortion (Intermodulation Distortion)

#### Command Format:

/NL, Qqqq, Cccc, Mm, Xx, Yy/

#### Command Group Description:

This controls second and third order nonlinear distortion functions.

#### Command Definitions:

**Qqqq** - controls second order distortion level in 0.1 dB steps. Range is 200 to 600 (20.0 to 60.0 dB below signal, as measured by IEEE standard 4-tone technique). Default is 520 (52.0 dB below signal).

**Cccc** - controls third order distortion level in 0.1 dB steps. Range is 200 to 600 (20.0 to 60.0 dB below signal). Default is 500 (50.0 dB below signal).

**Mm** - controls nonlinear distortion mode; expansive (0) or compressive (1). Default is 0 (expansive)

**Xx** - controls second order distortion on (1) or off (0). Default is 0 (off).

**Yy** - controls third order distortion on (1) or off (0). Default is 0 (off).

#### Response Formats:

/C/  
or  
/NL03, Eeee/

**NOTE:** For units equipped for bidirectional impairment simulation, see /AD,Ii/ command. To switch between the algorithms, see /AD,S02/ command.

### 3.6.19. PCM/ADPCM

#### Command Format:

`/PC, Cjc, Qjq, Ee, Ii, Bb, Pp, Ss, Ddddd, Mm/`

#### Command Group Description:

This controls the PCM/ADPCM Links simulation module. For units equipped for bidirectional impairment simulation, see `/AD,Ii/`.

#### Command Definitions:

**Cjc** - selects the coding for the specified link. Coding optimizes the dynamic range of the analog data sample. Your choices for coding are A-law and mu-law, which compress approximately 13 bits of dynamic range into 8 bits. Mu-law is the companding characteristic adopted by the U.S. and Japan, while A-law is the companding characteristic recommended by CCITT.

'j' specifies the link:

- 1 = Link 1
- 2 = Link 2
- 3 = Link 3
- 4 = Link 4

'c' specifies the coding:

- c = 0 selects no coding (analog bypass)
- c = 1 selects a-law PCM
- c = 2 selects mu-law PCM
- Default is 0 (no coding)

**Qjq** - selects the PCM rate (quantization) for the specified link.

'j' specifies the link:

- j = 1 - Link 1
- j = 2 - Link 2
- j = 3 - Link 3
- j = 4 - Link 4

'q' selects the rate:

- q = 0 selects 64 kbps
- q = 1 selects 16 kbps
- q = 2 selects 24 kbps (CCITT G.723/ANSI T1Y1/87-040)
- q = 3 selects 32 kbps (CCITT G.721/ANSI T1.301-1987)
- q = 4 selects 40 kbps (CCITT G.723/ANSI T1Y1/87-040)
- Default is 3 (32 kbps).

**Pp** - controls the Robbed Bit Signaling data selection which allows you to set the PCM robbed bit signaling data bits for a channel in one of the four links. When a bit pattern is selected, the least significant bit for the channel of every sixth frame is robbed and replaced with the appropriate bit in the pattern. (A frame refers to a T1 frame of 125 microseconds duration.) Since the pattern is four bits long, it repeats itself every 24 frames. The choices are the 16 patterns from 0000 to 1111, which represent bit positions A, B, C, and D. The choice of RBS pattern should be made with the Dddd parameter.

The bits will be robbed as follows:

- A = least significant bit of sixth frame
- B = least significant bit of twelfth frame
- C = least significant bit of eighteenth frame
- D = least significant bit of twenty-fourth frame

Robbed Bit Signaling can be done on a single link. 'p' specifies the link:

- 1 = Link 1
- 2 = Link 2
- 3 = Link 3
- 4 = Link 4
- Default is 1 (Link 1)

**Dddd** - controls the PCM robbed bit signaling data. 'ddd' specifies the A, B, C, and D signaling bits. Your choices are 0000 to 1111. Default is 0000.

**Ss** - disables (s = 0) or enables (s = 1) PCM robbed bit signaling. Default is 0 (disable).

**Ee** - specifies the link for PCM or ADPCM bit error injection. Errors can be injected in any one of the four possible links.

'e' specifies the specific link:

- 1 = Link 1
- 2 = Link 2
- 3 = Link 3
- 4 = Link 4
- Default is 1 (Link 1)

**Ii** - selects PCM or ADPCM bit error injection for the selected link. i = 0 selects PCM and i = 1 selects ADPCM. Default is 0 (PCM).

**Bb** - controls the injected bit error rate.

'b' selects the rate:

0 = No errors

1 = (2E-20)

2 = (2E-17)

3 = (2E-13)

4 = (2E-10)

5 = (2E-7)

6 = (2E-3)

Default is 0 (no errors)

**Mm** - configures the position of the PCM/ADPCM Link (PAL) module. You can position the PAL module either before satellite delay or after the impairment summer.  $m = 0$  positions the PAL module before satellite delay, and  $m = 1$  positions the PAL module after the impairment summer. Default is 1 (PAL module after impairment summer).

**NOTE:** When the EPAL module is present, the /PC,Mm/ command positions the entire digital channel (both PAL and EPAL) the same as the /EP,Mm/ command. For more information on this see /EP,Mm/ and the Features Description section.

**Response Formats:**

/C/

or

/PC25, Eeee/



### 3.6.20. Phase Hits

#### Command Format:

/PH,Lllll,Rrrrr,Dddddd,Iiiii,Mm,[Ss or T]/

#### Command Group Description:

This controls the phase hit function.

#### Command Definitions:

**Lllll** - controls phase hit level in units of .022 degrees (180 degrees/8192). Range is 0 to 8192 (0.0 degrees to 180.0 degrees). Default is 2048 (45.0 degrees).

**Rrrrr** - controls phase hit risetime in units of 0.1 msec. Range is 2 to 9900 (0.2 to 990.0 msec). Default is 2 (0.2 msec).

**Dddddd** - controls phase hit duration in units of 0.625 msec. Duration (D) must be greater than risetime (R). Range is 3 to 32000 (1.875 msec to 20000 msec). Default is 8 (5 msec).

**Iiiii** - controls phase hits interval in units of 0.01 sec. Interval must be greater than duration plus risetime. Range is 10 to 32000 (0.1 sec to 320 sec). Default is 100 (1.0 sec).

**NOTE:** The least significant digit of the programmed setting has no effect on the interval time.

**Mm** - provides pseudorandom (1) or regular (0) phase hit arrival time (trigger) mode. Default is 0 (regular).

**Ss** - controls phase hits on (1) or off (0). Default is 0 (off).

**T** - initiates a single phase hit.

#### Response Formats:

/C/  
or  
/PH06,Eeee/

**NOTE:** For units equipped for bidirectional impairment simulation, see /AD,Ii/. Phase Hits is disabled for ETSI-2 Test Channel Configuration, see /AD,Tt/ command.

### 3.6.21. Phase Jitter

#### Command Format:

`/PJ, Llllll, Fffff, Ww, Ss/`

#### Command Group Description:

This controls the phase jitter function.

#### Command Definitions:

**Lllll** - controls the phase jitter level in units of 0.022 degrees (90 degrees/4096). Range is 0 to 4096 (0 to 90.0 degrees peak-peak). Default is 0.

**Fffff** - controls the phase jitter frequency in 0.1 Hz steps. Range is 0 to 3000 (0.0 Hz to 300.0 Hz). This command is invalid when the phase jitter waveform is noise. Default is 600 (60.0 Hz).

**Ww** - controls the phase jitter modulation waveform:

- 0 = sine
  - 1 = full-wave rectified sine
  - 2 = half-wave rectified sine
  - 3 = 300 Hz bandlimited noise
- Default is 0 (sine).

**Ss** - controls phase jitter on (1) or off (0). Default is 0 (off).

#### Response Formats:

`/C/`  
or  
`/PJ05, Eeee/`

<p><b>NOTE:</b> For units equipped for bidirectional impairment simulation, see <code>/AD,li/</code> command. Phase Jitter is disabled for ETSI-2 Test Channel Configuration, see <code>/AD,Tt/</code> command.</p>
---

### 3.6.22. White Noise

#### Command Format:

/RN, L111, Ww, Bb, Pp, Ss/

#### Command Group Description:

This controls the white noise generator.

#### Command Definitions:

**L111** - controls the white noise output level in units of 0.1 dBrn. Range is 150 to 900 (15.0 to 90.0 dBrn). Default is 320 (32.0 dBrn).

**Ww** - controls white noise output level correction for various instrument measuring filters:

- 0 = c-message
- 1 = 3 kHz Flat
- 2 = 15 kHz Flat
- 3 = NET 20
- 4 = Psophometric
- Default is 0 (c-message)

**Bb** - controls white noise output frequency bandwidth:

- 0 = 5 kHz
- 1 = 4 kHz
- 2 = 20 kHz
- Default is 0 (5 kHz)

**Pp** - controls the period of the pseudorandom noise generator:

- 0 = 20.97 seconds
- 1 = 5.97 hours
- Default is 0 (20.97 seconds)

**Ss** - controls white noise on (1) or off (0). Default is 0 (off).

#### Response Formats:

/C/  
or  
/RN14, Eeee/

**NOTE:** For units equipped for bidirectional impairment simulation, see /AD, Ii/. /RN, Pp/ is not affected by /AD, Ii/, because the pseudorandom period is defined for both directions.

### 3.6.23. Satellite Delay 1 EIA/CCITT and ETSI-1 Test Channel Configurations

**Command Format:**

/SAT1, Dddddd, Ss/

**Command Group Description:**

Controls the channel time delay for EIA/CCITT and ETSI-1 Test Channel Configurations (see /AD,Tt/).

**Command Definitions:**

**Dddddd** - controls the channel time delay in 0.125 msec. steps. Range is 0 to 10239 (0 to 1279.875 msec.). Default is 2500 (approx. 312.5 msec.).

**Ss** - enables delay at the current value (s=1) or disables delay (s=0). Default is 0 (disabled).

**Response Formats:**

/C/  
or  
/SAT1, Eeee/

**NOTE:** For units equipped for bidirectional impairment simulation, see /AD,Ii/ when programming satellite delay. SAT1 Satellite Delay is disabled for ETSI-2 Test Channel Configuration, see /AD,Tt/ command. For ETSI-2 Test Channel Configuration satellite delay controls, see SAT2 commands.

### 3.6.24. Satellite Delay 2 ETSI-2 Test Channel Configuration

**Command Format:**

/SAT2 , Ddddd , Ss /

**Command Group Description:**

Controls the channel time delay for ETSI-2 Test Channel Configurations (see /AD,Tt/).

**Command Definitions:**

**Ddddd** - controls the channel time delay in 0.125 msec. steps. Range is 0 to 3400 (0 to 425.0 msec.) for ETSI-2 Test Channel Configuration (see /AD16,Tt/). Default is 2500 (approx. 312.5 msec.).

**Ss** - enables delay at the current value (s=1) or disables delay (s=0). Default is 0 (disabled).

**Response Formats:**

/C/  
or  
/SAT2 , Eeee /

**NOTE:** For units equipped for bidirectional impairment simulation, see /AD,Ii/ when programming satellite delay. SAT2 Satellite Delay is disabled for EIA/CCITT and ETSI-1 Test Channel Configurations, see /AD,Tt/ command. For EIA/CCITT and ETSI-1 Test Channel Configurations satellite delay controls, see SAT1 commands.

### 3.6.25. Single Frequency Interference (SFI)

#### Command Format:

*/SF, Fffff, Iiiii, Llll, Mm, Pppp, Qq, Ss, Xxxxx, Yyyyy/*

#### Command Group Description:

This controls the single frequency interference function.

#### Command Definitions:

**Fffff** - controls SFI frequency in Hertz. Range is 120 to 3400 (120 Hz to 3400 Hz). Default is 2600 (2600 Hz).

**Iiiii** - controls the frequency increment (step) of the sweep in Hertz. Range is 1 to 100 (1 to 100 Hz). Default is 10(10 Hz).

**Llll** - controls the SFI level in units of 0.1 dB. Range is 0 to 500 (0.0 to 50.0 dB below signal). Default is 100 (10.0 dB below signal).

**Mm** - controls the mode of SFI generator frequency sweep. If SFI is off when a sweep mode command is sent the new mode will only be in effect after SFI is turned on.

m = 0, frequency sweep is disabled. Frequency specified by Fffff is generated

m = 1, single frequency sweep. Begins with smallest frequency value and steps (/SF,Iiiii/) to the largest frequency

m = 2, continuous frequency sweep. Begins with smallest frequency value, and steps (/SF,Iiiii/) to the largest frequency, then steps back down to the smallest frequency value, then repeats

Default is m = 0 (sweep disabled)

**Pppp** - controls the period of the sweep in seconds. Range is 1 to 999 (1 to 999 seconds). Period is the length of time to complete one sweep. Default is 300 (300 seconds).

**Qq** - controls an offset to the frequency specified by q in 1/3 Hertz steps. Range is 0 to 2 (0 to 2/3 Hz). Default is 0 (no offset).

**Ss** - controls SFI generator on (1) or off (0). Default is 0 (off).

**Xxxxx** - controls the limit of the frequency sweep in Hertz. Range is 16 to 3400 Hz. Default is 300 Hz. Note: this should not be set equal to 'Yyyyy' command.

**Yyyyy** - controls the limit of the frequency sweep in Hertz. Range is 16 to 3400 Hz. Default is 3400 Hz. Note: this should not be set equal to 'Xxxxx' command.

Which ever is the lower frequency 'xxxx' or 'yyyy' will be the starting frequency for the frequency sweep mode.

**Response Formats:**

/C/  
or  
/SF11, Eeee/

**NOTE:** For units equipped for bidirectional impairment simulation, see /AD,li/.

### 3.6.26. Network Signaling

#### Command Format:

```
/SG,Aaaa,Bjbbb,Cc,D<->dd,Ee,Fjfffff,  
Iii,Jijj,Kjk,Lll,Mm,Pjpp,Qq,Rjrrr,  
Ss,Ww,Yyyy,Zz/
```

#### Command Group Description:

This controls the network simulator module signaling parameters.

#### Command Definitions:

**Aaaa** - controls the ring level in 1 Vrms steps. Range is 1 to 100 (1 to 100 Vrms). Activated by /AD,S05=01/ command. Default is 85 Vrms.

**Bjbbb** - controls busy cadence.

'j' determines the cadence time to be set:

A = busy on time (default 10)

B = busy off time (default 10)

'bbb' determines cadence time in 50 msec steps. Range is 0 to 1200 (0 msec to 60000 msec).

**Cc** - selects the control mode for signaling frequency (see /SG,Fjffff/) and cadence (see /SG,Rjrrr/) parameters. The following choices for 'c' are:

0 = Primary Parameters (Default)

1 = Set 1 Secondary Parameters (Primary Dial Tone Cadence)

2 = Set 2 Secondary Parameters (Secondary Dial Tone)

3 = Set 3 Secondary Parameters (Routing Tone)

**D-dd** - controls the level of primary dial tone, secondary dial tone and routing tone in units of 1 dBm. Range is 0 to -50 (0 to -50 dBm). Default is -10 dBm.

**Ee** - enables (1) or disables (0) routing tone. Default is 0 (disabled).



**Fjffff** - controls frequencies for signaling tones of the selected parameter set (see /SG,Cc/).

'j' determines the tone to be set:

A = primary dial tone frequency 1 (default 3500) (/SG,C0/ or /SG,C1/) or secondary dial tone frequency 1 (default 3500) (/SG,C2/) or routing tone frequency 1 (default 4400) (/SG,C3/)

B = primary dial tone frequency 2 (default 4400) (/SG,C0/ or /SG,C1/) or secondary dial tone frequency 2 (default 4400) (/SG,C2/) or routing tone frequency 2 (default 4400) (/SG,C3/)

C = busy frequency 1 (default 4800)

D = busy frequency 2 (default 6200)

E = audible ring frequency 1 (default 4400)

F = audible ring frequency 2 (default 4800)

'ffff' determines the tone frequency in units of 0.1 Hz. Range is 1000 to 34000 (100.0 to 3400.0 Hz).

**Iii** - controls the DC loop current selection in 6 mA steps. Range is 3 to 15 (18 to 90 mA). ii=0 along with /LC,M1/ connects station A to station B and disables all automatic signaling (selects 2 wire private line). Enabled by /AD,S04=00/ command. Default is 3 (18 mA).

**Jijj** - controls the DC loop current selection in 2 mA steps. 'i' selects the station:

A - station A

B - station B

'jj' selects the loop current. Range is 5 to 63 (10 to 126 mA in 2 mA steps). Enabled by /AD,S04=01/ command. Default is 9 (18 mA).

**Kjk** - controls station A or B loop current polarity. 'j' selects the station:

A - station A

B - station B

'k' selects the loop current polarity:

0 - positive (Tip to Ring)

1 - Negative (Tip to Ring)

Default is 0 (positive)

**Lll** - controls the ring level in 5 Vrms steps. Range is 1 to 20 (5 to 100 Vrms). Default is 17 (85 Vrms).

**Mm** - changes status of selected station to busy. 'm' is one of the following:

- A = make station A busy
- B = make station B busy
- C = clear (default)

**Pjpp** - controls dial pulse make break intervals.

'j' determines the interval to be set:

- A = minimum break time (default 45)
- B = maximum break time (default 75)
- C = minimum make time (default 25)
- D = maximum make time (default 55).

'pp' determines the time length of the interval in 1 msec steps. Range is 10 to 90 (10 msec to 90 msec).

Dial pulse digits that do not meet the specified break/make intervals are not recognized.

**Qq** - selects the DC Ringing Bias for ringing. Selections for 'q' are as follows:

- 0 - Vbattery (see /LC,Vv/ command). (default)
- 1 - Vbattery/2 + 12 Volts (see /LC,Vv/ command)
- 2 - Vbattery/2 (see /LC,Vv/ command)
- 3 - 12 volts

**Rjrrr** - controls on/off cadence of the selected parameter set (see /SG,Cc/).

'j' determines the cadence time to be set:

- A = ringing/ring back on time 1 (default 0) (/SG,C0/) or primary dial tone on time 1 (default 0) (/SG,C1/) or secondary dial tone on time 1 (default 0) (/SG,C2/) or routing tone on time 1 (default 0) (/SG,C3/)
- B = ringing/ring back on time 2 (default 0) (/SG,C0/) or primary dial tone on time 2 (default 0) (/SG,C1/) or secondary dial tone on time 2 (default 0) (/SG,C2/) or routing tone on time 2 (default 0) (/SG,C3/)
- C = ringing/ring back on time 3 (default 40) (/SG,C0/) or primary dial tone on time 3 (default 4) (/SG,C1/) or secondary dial tone on time 3 (default 40) (/SG,C2/) or routing tone on time 3 (default 1) (/SG,C3/)
- D = ringing/ring back off time 1 (default 0) (/SG,C0/) or primary dial tone off time 1 (default 0) (/SG,C1/) or secondary dial tone off time 1 (default 0) (/SG,C2/) or routing tone off time 1 (default 0) (/SG,C3/)
- E - ringing/ring back off time 2 (default 0) (/SG,C0/) or primary dial tone off time 2 (default 0) (/SG,C1/) or secondary dial tone off time 2 (default 0) (/SG,C2/) or routing tone off time 2 (default 0) (/SG,C3/)
- F - ringing/ring back off time 3 (default 80) (/SG,C0/) or primary dial tone off time 3 (default 0) (/SG,C1/) or secondary dial tone off time 3 (default 0) (/SG,C2/) or routing tone off time 3 (default 1) (/SG,C3/)

'rrr' determines cadence time in 50 msec steps. Range is 0 to 1200 (0 msec to 60000 msec)

**Ss** - selects and sends a signal to either station. Choices for s are A to G:

s =    A = send ringing to station A  
        B = send ringing to station B  
        C = send primary dial tone to station A  
        D = send primary dial tone to station B  
        E = send busy to station A  
        F = send busy to station B  
        G = clear all. (default)

**Ww** - selects the polarity of the ringing signal. Selections for w are as follows:

w = 0 - positive (default)  
 w = 1 - negative

**Yyyy** - controls the ring frequency in units of 0.1 Hz. Range is 140 to 1200 (14.0 to 120.0 Hz). Default is 200 (20.0 Hz).

**Zz** - initiates a report of the line status. A causes the simulator to report the status of station A. B causes the network simulator to report the status of station B. The line status is valid only in the switched line mode.

#### **Response Formats:**

/C/  
 or  
 /SG20, Eeee/  
 or  
 /SG20, Zzzzzzzzz/ (status command only)

#### **Response Command Definitions (Status Command Only):**

**Zzzzzzzzz** - contains station status. The status digits from left to right, are:

1. Audible ringing on (1)
2. Ringing on (1)
3. Busy on (1)
4. Dial tone on (1)
5. Off hook (1)
6. Connected(1)
7. Awaiting DTMF(1)
8. Awaiting dial pulses(1)

### 3.6.27. Switching

#### Command Format:

/SW, Tjtttttttttttttttttt, Mmmmmm, Nnnnnn, Qqqq, Zz/

#### Command Group Description:

This controls the network simulator switching parameters.

#### Command Definitions:

**Tjtttttttttttttt** - sets the telephone number for station A or B.

'j' determines which telephone number is set:

A = station A

B = station B

'tttttttttttt' contains the telephone number (up to 15 decimal digits). Default telephone number for station A is 5550123. Default telephone number for station B is 5559876. Digits supported are 0 through 9, \*, #, and + (plus sign). The plus sign functions as a second dial tone request.

**Mmmmmm** - controls the switching delay, i.e., the time between the end of the dialing sequence and the connection of the call, and is measured in 1 msec steps. Range is 1 to 60000 (1 to 60000 msec). Default is 1.

**Nnnnnn** - controls the dial tone delay, i.e., the time between station off-hook to dial tone, and is measured in 1 msec steps. Range is 1 to 60000 (1 to 60000 msec). Default is 1.

**Qqqq** - controls the on-hook recognition disconnect delay, i.e., the time from station on-hook to recognition of on-hook status at the line control unit. This time is specified in 1 msec steps. Range is 1 to 255 (1 msec to 255 msec). Default is 255.

**Zz** - reads back the Station Telephone number for station A or B. 'z' determines which telephone number is to be read back:

A - station A

B - station B

**Response Formats:**

```
          /C/  
          or  
/SW21,ZAzzzzzzzzzzzzzzzzzz/ for station A  
          or  
/SW21,ZBzzzzzzzzzzzzzzzzzz/ for station B  
          or  
          /SW21,Eeee/
```

### 3.6.28. Tone Generator

**Command Format:**

`/TN, Fffff, Ss/`

**Command Group Description:**

Controls the general-purpose tone generator. For units equipped for bidirectional impairment simulation, see `/AD,li/` command.

**Command Definitions:**

**Fffff** - controls tone frequency in Hertz. Range is 200 to 3,400 (200 Hz to 3,400 Hz). Default is 1,004.

**Ss** - controls tone generator on (1) or off (0). Default is 0.

**Response Formats:**

`/C/`  
or  
`/TN01, Eeee/`

### 3.7. Superseded Command Descriptions

This section describes commands which may be discontinued in the future and those that are currently discontinued. These commands are not recommended for new applications. Where applicable the replacement commands are given to allow existing scripts to be updated. If there are questions about command availability, please contact Customer Service.

#### 3.7.1. Auxiliary (Intermediate or Listener) Echo

The AE command is discontinued. The replacement commands are AXE1 for the EIA/CCITT and ETSI-1 Test Channel Configurations and AXE2 for ETSI-2 Test Channel Configuration.

##### Command Format:

`/AE, Ddddd, Llll, Tt, Ss/`

##### Command Group Description:

Controls the auxiliary echo (intermediate talker or listener echo) function. For units equipped for bidirectional impairment simulation see `/AD,li/`.

##### Command Definitions:

**Ddddd** - controls the auxiliary echo time delay in 0.125 msec. steps for the selected station interface. Range of "dddd" is 0 to 7000 (0 to 875.0 msec.) for EIA/CCITT and ETSI-1 Test Channel Configurations (see `/AD,Tt/` command). Range is 0 to 2320 (0 to 290.0 msec.) for ETSI-2 Test Channel Configuration. Default is 160 (approx. 20 msec.).

**L<+/->lll** - controls the auxiliary echo level in 0.1 dB steps for the selected station interface. Range of "lll" is 0 to 400 (0 to 40.0 dB attenuation for listener echo or 0 to 40.0 dB below signal level for intermediate talker echo). Default is 200 (20.0 dB).

**Tt** - selects intermediate talker (0) or listener (1) echo (type) for the selected station interface. Default is 0 (intermediate talker echo).

**Ss** - enables (1) or disables (0) auxiliary echo for the selected station interface. Default is 0 (disabled).

##### Response Formats:

`/C/`  
or  
`/AE28, Eeee/`

### 3.7.2. Satellite Delay/Echo

This command is equivalent to EC and SAT1 commands. It is highly recommended that EC and SAT1 be used instead of ED. Support for the ED command may be discontinued in the future and is only available in EIA/CCITT Test Channel Configuration. /ED,Ddddd, Yy/ commands will alter the database parameters for the associated SAT1 and EC commands, and the associated EC and SAT1 commands will alter the database parameters for the ED commands.

#### Command Format:

/ED, Ddddd, Lj<+/->lll, Pjp, Aa, Xx, Yy/

#### Command Group Description:

This controls the channel time delay and the near/far echo attenuators. Equivalent commands are SAT1 and EC. SAT1 and EC commands will alter the database parameters for the associated ED commands, and /ED,Lj<+/->lll,Pjp,Xx/ commands will alter the database parameters for the associated EC and SAT1 commands.

#### Command Definitions:

**Ddddd** - controls the channel time delay in 0.125 msec steps. Range is 0 to 10239 (0 to 1279.875 msec). Default is 5230 (approx. 653 msec).

**Lj<+/->lll** - controls one of four echo attenuators.

'j' selects the echo attenuator:

- A - Station A Near End Echo Attenuator
- B - Station A Far End Echo Attenuator
- C - Station B Near End Echo Attenuator
- D - Station B Far End Echo Attenuator

'lll' determines the echo attenuator setting in 0.1 dB steps. Range is -100 to +400 (10.0 dB echo gain to 40 dB echo attenuation. Default for lll is 210 (21.0 dB attenuation).

**Pjp** - controls echo attenuator path polarity. j selects the echo attenuator path:

- A - Station A Near End Echo Attenuator path
- B - Station A Far End Echo Attenuator path
- C - Station B Near End Echo Attenuator path
- D - Station B Far End Echo Attenuator path

p=0 makes the echo path noninverting. p=1 inverts the echo path signal. Default for p is 0 (noninverting).



**Aa** - has no effect in Series II systems. It was used to enable the delay/echo module (a=1) or disable the delay/echo module (a=0) in the TAS 1010. Default is 1 (enabled).

**Xx** - enables all echo attenuators at the current attenuator settings (x=1) or disables (sets to maximum attenuation) all echo attenuators (x=0). Default is 0 (disabled).

**Yy** - enables delay at the current value (y=1) or disables delay (y=0). Default is 0 (disabled).

**Response Formats:**

/C/  
or  
/ED24 , Eeee/

**NOTE:** For units equipped for bidirectional impairment simulation and when programming satellite delay (using /ED,Ddddd,Yy/), see /AD,Ii/. The ED Command is disabled for ETSI-1 and ETSI-2 Test Channel Configurations, see /AD,Tt/ command.

### 3.7.3. Impulse Noise

This command is replaced with IMP1 and IMP2 commands in the following manner:

The IEEE impulse features for the IM command will be discontinued in the future but is still available in the EIA/CCITT and ETSI-1 Test Channel Configurations. The new command IMP1 currently replaces the IEEE impulse command features and is recommended for future use.

Support for the Bipolar impulse features for the IM command is discontinued in this release, and is replaced by the IMP2 command. Several step size values for the Bipolar impulse features have been changed.

The /IM,C/ command is no longer available, and has been replaced with the /AD,S01/ command.

#### Command Format:

```
/IM10, Lllll, Iiiii, Ddd, Ww, Mm, Pppp, Cc, [Ss or T] /
```

#### Command Group Description:

This controls the impulse noise function.

#### Command Descriptions:

**Lllll** controls the impulse noise level.

For IEEE standard impulse (see /IM10,C0/), the following information applies:

Level in units of 0.1 dB

Range is 200 to 1000 (20.0 dB<sub>rn</sub> to 100.0 dB<sub>rn</sub>)

Default is 340 ( 34.0 dB<sub>rn</sub> )

For bipolar pulse (see /IM10,C1/), the following information applies:

Level in units of 10 mV<sub>peak</sub>

Range is 2 to 480 (20 mV<sub>peak</sub> to 4800 mV<sub>peak</sub>)

Default is 340 ( 3400 mV<sub>peak</sub>)

**Iiiii** controls the interval between impulse hits.

For IEEE Standard impulse (see /IM10,C0/), the following information applies:

Range is 10 to 32000 (0.1 sec to 320.0 sec)

Default is 100 (1.0 sec)

For bipolar pulse (see /IM10,C1/), the following information applies:

Range is 1 to 60000 (1 msec to 60000 msec)

Default is 100 (100 msec).

**Ddd** controls the pulse duration for bipolar pulses (see /IM10,C1/) in units of 0.125 msec. Range is 1 to 80 (0.125 msec to 10 msec). Default is 2 (0.250 msec).

**Ww** controls impulse output level correction for various instrument measuring filters:

0 = c-notch

1 = (reserved)

Default is 0 (c-notch)

**Mm** controls impulse arrival time (trigger) mode:

0 = regular internal trigger

1 = pseudorandom internal trigger

2 = regular external trigger (pause/impulse sequence is started on the falling edge of each external trigger pulse)

3 = single shot external trigger (once armed by the /IM10,T/, a single pause/impulse sequence is started on the next falling edge of the external trigger pulse). /IM10,Ss/ has no effect on this mode

Default is 0 (regular)

**Pppp** controls the pause (time delay from the occurrence of an external trigger to the start of an impulse). Pause is in units of 0.125 msec. Range is 0 to 800 (0 to 100 msec). Default is 0 (0 msec)

**Cc** controls impulse type:

0 = IEEE Standard. Note that level (L) and interval (I) must be in the allowed range for proper operation (see /IM10,Llll/ and /IM10,Iiiii/)

1 = Bipolar Pulse. Note that level (L) and interval (I) must be in the allowed range for proper operation (see /IM10,Llll/ and /IM10,Iiiii/)

Default is 0 (IEEE Standard)

**Ss** controls impulse noise on (1) or off (0). Default is 0 (off).

**T** generates a single internal impulse trigger or arms a single shot external trigger (see /IM10,M3/). Note that this command contains no parameter.

### Response Formats:

/C/  
or  
/IM10, Eeee/

### 3.7.4. Impairment Generator I/O

This command is replaced with the /IO,Ee/ commands. It is highly recommended that /IO,Jjj/ no longer be used, and that all /IO,Jjj/ commands be replaced with /IO,Ee/ command. Support for the /IO,Jjj/ command has been discontinued.

#### Command Format:

/IO, Jjj/

#### Command Group Description:

This controls the input/output configuration for the TAS Series II network simulator impairment generators.

#### Command Definitions:

**Jjj** - controls the signal monitor selection for display of a signal at the scope output port (A→B). Selections are defined as follows:

jj	Signal Selection
0	station a transmit signal
1	station b receive 4 wire
2	station b receive 4 wire
3	station b receive 4 wire
4	station b receive 4 wire
5	station b receive 4 wire
6	station b receive 4 wire
7	station b receive 4 wire
8	station b receive 4 wire
9	station b receive 4 wire
10	station b receive 4 wire
11	station b receive 4 wire
12	station b receive 4 wire
13	station b receive 4 wire
14	station b receive 4 wire
15	station b receive 4 wire

Default is 0 (station a transmit signal)

**NOTE:** Due to differences in the hardware implementation between the 1010 and Series II, selections for J1 to J15 are identical. This represents the best approximation to the 1010's functionality that the Series II can achieve.

#### Response Formats:

/C/  
or  
/IO12, Eeee/

### 3.7.5. Line Control

The reverse channel attenuation controls (LC,H and LC,R commands) have been replaced with B→A input (IO,R command) and output (IO,T command) attenuator level controls, and with the A→B input (IO,I command) and output (IO,L command) attenuator level controls.

**Command Format:**

/LC, Hhhh, Rr/

**Command Group Description:**

This controls the central office network simulator line configuration parameters.

**Command Definitions:**

**Hhhh** - controls reverse channel attenuation in 0.1 dBm steps. Range is 0 to 500 (0 to 50.0 dBm). Default is 130 (13.0 dBm).

**NOTE:** This command should not be used for units equipped for bidirectional impairment simulation.

**Rr** - sets the reverse channel (impairment generator 2) off (infinite attenuation) (1), or on (0). Default is 0 (on).

**Response Formats:**

/C/  
or  
/LC23, Eeee/

### 3.7.6. Channel Interruptions

This command is equivalent to MIC1. It is highly recommended that MIC1 be used instead of MC. Support for the MC command will be discontinued in the future. MC commands will alter the database parameters for the associated MIC1 commands, and MIC1 commands will alter the database parameters for the associated MC commands.

#### Command Format:

```
/MC,Ddddd,Iiiii,[Ss or T]/
```

#### Command Group Description:

This controls the network simulator channel interruption function. For units equipped for bidirectional impairment simulation, see /AD,Ii/.

#### Command Definitions:

**Ddddd** - controls the cutoff duration in units of 1 msec. Range is 1 to 20000 (1 msec to 20000 msec). Default is 10 (10 msec).

**Iiiii** - controls the interval between periodic cutoffs. Interval must be greater than duration. Range is 10 to 32000 (0.1 sec to 320.0 sec). Default is 100 (1.0 sec).

**Ss** - controls cutoff on (1) or off (0). Default is 0 (off).

**T** - triggers a single cutoff. Note that this command contains no parameter.

#### Response Formats:

```
/C/  
or  
/MC26,Eeee/
```

### 3.7.7. Switching

This command is replaced by the LC,M3 command. It is recommended that the SW,Ss command no longer be used since support for the SW,Ss command will be discontinued in the future. SW,Ss and LC,M3 commands will alter the same hardware within the Series II, so extreme care should be taken if both of these commands are used.

**Command Format:**

/SW, Ss/

**Command Group Description:**

This controls the network simulator switching parameters.

**Command Definitions:**

**Ss** - activates (1) or deactivates (0) autoswitch mode. While the autoswitch mode is active, stations A and B are connected whenever they are both off-hook. No dialing sequence is required. Default is 0 (deactivated).

**Response Formats:**

/C/  
or  
/SW21, Eeee/

This page intentionally left blank.



## 4.0. TAS SERIES II ERROR CODES

---

<b>Error Code</b>	<b>Description</b>
001	Parameter value error
002	Command syntax error
003-004	Reserved
005	A→B Signaling Generator calibration failure
006	A→B Transmission Channel Output Circuit calibration failure
007	A→B SFI Generator (SP3A #1) calibration failure
008	A→B Noise Filter #1 (5 kHz) calibration failure
009	A→B Input AGC failure (input signal level not between -23.0 dBm to + 7.0 dBm)
010-012	Reserved
013	Central office Module A (NIM 2A) not present
014	Reserved
015	A→B Impairments Generator (SP3A #1) not present
016	Reserved
017	A→B Output AGC failure (can't compensate for channel rolloff)
018	A→B Output AGC failure (output level below capture range)
019	A→B PCM/ADPCM Module (SP3C #1) not present
020-025	Reserved
026	A→B Impulse Noise Generator (SP3A #1) calibration failure
027	Reserved
028	A→B Noise Filter #2 (4 kHz) calibration failure

<b>Error Code</b>	<b>Description</b>
029-037	Reserved
038	A→B Noise Filter #3 (20 kHz) calibration failure
039-040	Reserved
041	A→B Impairments Generator (SP3A #1) bad response
042	A→B Impairments Generator (SP3A #1) did not accept data
043	A→B Impairments Generator (SP3A #1) no response
044-060	Reserved
061	Central Office Module (NIM 2A) bad response
062	Central Office Module (NIM 2A) did not accept data
063	Central Office Module (NIM 2A) no response
064-070	Reserved
071	Channel Access Module (SP3B) bad response
072	Channel Access Module (SP3B) did not accept data
073	Channel Access Module (SP3B) no response
074	Reserved
075	A→B Signal Generator level failure
076	A→B Input Circuit level failure
077	A→B Impairments Generator (SP3A #1) level failure
078	A→B Transmission Channel Output Circuit level failure
079	A→B Summer Circuit level failure
080-084	Reserved
085	Station B 4 Wire Receive level failure
086	Station B 2 Wire Receive level failure

<b>Error Code</b>	<b>Description</b>
087	A→B Dial Tone level failure
088	Reserved
089	A→B PCM/ADPCM Module (SP3C #1) level failure
090	Reserved
091	A→B PCM/ADPCM Module (SP3C #1) bad response
092	A→B PCM/ADPCM Module (SP3C #1) did not accept data
093	A→B PCM/ADPCM Module (SP3C #1) no response
094	Reserved
095	Extended PCM/ADPCM (EPAL) bad response
096	Extended PCM/ADPCM (EPAL) did not accept data
097	Extended PCM/ADPCM (EPAL) no response
098	Reserved
099	Cellular Audio Processing Module (CAP) bad response
100	Cellular Audio Processing Module (CAP) did not accept data
101	Cellular Audio Processing Module (CAP) no response
102-104	Reserved
105	B→A Signaling Generator calibration failure
106	B→A Transmission Channel Output Circuit calibration failure
107	B→A SFI Generator (SP3A #2) calibration failure
108	B→A Noise Filter #1 (5 kHz) calibration failure
109	B→A Input AGC failure (input signal level not between -23.0 dBm to + 7.0 dBm)
110-112	Reserved
113	Central Office Module B (NIM 2B) not present

<b>Error Code</b>	<b>Description</b>
114	Reserved
115	B→A Impairments Generator (SP3A #2) not present
116	Reserved
117	B→A Output AGC failure (can't compensate for channel rolloff)
118	B→A Output AGC failure (output level below capture range)
119	B→A PCM/ADPCM Module (SP3C #2) not present
120-125	Reserved
126	B→A Impulse Noise Generator (SP3A #2) calibration failure
127	Reserved
128	B→A Noise Filter #2 (4 kHz) calibration failure
129-137	Reserved
138	B→A Noise Filter #3 (20 kHz) calibration failure
139-140	Reserved
141	B→A Impairments Generator (SP3A #2) bad response
142	B→A Impairments Generator (SP3A #2) did not accept data
143	B→A Impairments Generator (SP3A #2) no response
144-174	Reserved
175	B→A Signal Generator level failure
176	B→A Input Circuit level failure
177	B→A Impairments Generator (SP3A #2) level failure
178	B→A Transmission Channel Output Circuit level failure
179	B→A Summer Circuit level failure

<b>Error Code</b>	<b>Description</b>
180-184	Reserved
185	Station A 4 Wire Receive level failure
186	Station A 2 Wire Receive level failure
187	B→A Dial Tone level failure
188	B→A External 2 Wire Interface level failure
189	B→A PCM/ADPCM Module (SP3C #2) level failure
190	Reserved
191	B→A PCM/ADPCM Module (SP3C #2) bad response
192	B→A PCM/ADPCM Module (SP3C #2) did not accept data
193	B→A PCM/ADPCM Module (SP3C #2) no response
194	Invalid command for selected Central Office Emulation Mode
195-999	Reserved

This page intentionally left blank.

## 5.0. TECHNICAL SPECIFICATIONS

---

### 5.1. General

#### Power Requirements

Voltage 115/230 VAC (selectable) +10%, -13%

Frequency 48 to 63 Hz

Dissipation 200 watts maximum

#### Operating Environment

Temperature 0 to 50 degrees C (32 to 122 degrees F)

Humidity 10% to 90%, noncondensing

#### Dimensions and Weight

Height 8.75 inches

Width 16.88 inches

Depth 16.70 inches

Weight 34 pounds

## 5.2. Signal Measurement

### Level Measurement

Range	+8.0 dBm to -56.0 dBm
Resolution	0.1 dB
Accuracy	+/- 0.4 dBm
Measurement Points	Station A transmit Station A 4-wire receive Station A 2-wire receive Station B transmit Station B 4-wire receive Station B 2-wire receive

### Frequency Measurement

Signal Range	200 Hz to 3,200 Hz
Signal Resolution	1 Hz
Signal Accuracy	0.75%
Signal Level	≥ to -25 dBm



### 5.3. Impairments Generator I/O

#### Input Level

Range +7.0 dBm to -23.0 dBm

#### Output Level (1 kHz Tone)

Range 0.0 dBm to -50.0 dBm

Resolution 0.1 dB

Accuracy  
 +/- 0.2 dB @ 0 dBm  
 +/- 0.3 dB @ -40.0 dBm  
 +/- 0.7 dB @ -50.0 dBm

#### Residual Characteristics

Idle Channel Noise < 10 dBmC (-80 dBm) (All impairments off, output level = -20 dBm, stations A and B terminated in 600 ohms)

Residual Phase Jitter < 0.2 degrees

Residual Amplitude Jitter < 0.2 percent

Residual Propagation Delay Between Station A and B (1800 Hz)  
*Series II 1200 Model*  
 12.9 msec +/- 0.2 msec (EIA/CCITT Configuration)  
 15.8 msec +/- 0.2 msec (ETSI-1 Configuration)  
 1.7 msec +/- 0.2 mes (ETSI-2 Configuration)  
 < 0.05 msec (Analog Bypass Test Channel Configuration)  
*Series II 1200L Model*  
 < 0.05 msec

Residual 2nd Order Harmonic Distortion < -70.0 dBm (2 wire mode)  
 (Input =-7.0 dBm at 800 Hz, Output=-10.0 dBm)

Residual 3rd Order Harmonic Distortion < -70.0 dBm (2 wire mode)  
 (Input =-7.0 dBm at 800 Hz, Output=-10.0 dBm)

Channel Separation (Crosstalk in 4-wire mode) > 80 dB

Residual Frequency Shift < 0.005 Hz

**Internal Tone Generator**

Frequency Range	200 Hz to 3,400 Hz
Frequency Resolution	1 Hz
Frequency Accuracy	+/- 0.02 Hz +/- 0.01% of setting
Level Accuracy	(All impairments off, 0.0 dBm channel output level) +/- 0.3 dB @ 1000 Hz
Total Distortion	< -40 dB

## 5.4. Transmission Impairments

### Test Channel Configurations

Selections	EIA/CCITT ETSI-1 (NET 20 (ETS 300 114) Test Channel 1) ETSI-2 (NET 20 (ETS 300 114)Test Channels 2 & 3)
------------	---

### Single Frequency (Tone) Interference

Frequency Range	16 Hz to 3,400 Hz
Frequency Resolution	1/3 Hz
Frequency Accuracy	+/- 0.02 Hz +/- 0.01% of setting
Output Modes	Single Tone Single Sweep Continuos Sweep
Sweep Increment Range	1 Hz to 100 Hz
Sweep Increment Resolution	1 Hz
Sweep Increment Accuracy	0.02 Hz
Sweep Period	1 sec to 999 sec
Sweep Period Resolution	1 sec
Sweep Period Accuracy	+/- 0.05% of setting
Total Distortion	< -50 dB (300 Hz to 3400 Hz)
Relative Level	0.0 to -50.0 dB
Level Resolution	0.1 dB
Level Accuracy	Relative to Channel Output (freq=2600 Hz) +/-0.2 dB
Maximum Absolute Level (2 Wire Port)	0.0 dBm (100 to 3400 Hz) -16.0 dBm (< 100 Hz)

**White Noise**

Generator Type	pseudorandom
Period Choices	20.97 seconds or 5.97 hours
Crest Factor	approx. 4.7
Bandwidth Choices	4 kHz, 5 kHz (ETS 300 114), or 20 kHz
Level Calibration	C-Message, 3.0 kHz Flat, 15 kHz Flat, NET 20 (ETS 300 114), or Psophometric
Level Range	15.0 dBrn to 90.0 dBrn (-75.0 dBm to 0.0 dBm)
Level Resolution	0.1 dB
Level Accuracy	+/- 0.5 dB (20 dBrn to 90 dBrn (-70.0 dBm to 0.0 dBm) with C-Message calibration and a channel output level = -20 dBm)

**Intermodulation Distortion**

Mode	Expansive or Compressive
<i>Second Order Intermodulation Distortion</i>	
Range	20 to 60 dB below signal
Resolution	0.1 dB
Accuracy	0.5 dB (at 40 dB below signal)

*Third Order Intermodulation Distortion*

Range	20 dB to 60 dB below signal
Resolution	0.1 dB
Accuracy	0.5 dB (at 40 dB below signal)

**Frequency Shift**

Offset Choices	-9.995 to 9.995 Hz (mode 0) -199.9 to 199.9 Hz (mode 1)
Resolution	0.005 Hz (mode 0) 0.1 Hz (mode 1)
Accuracy	+/- 0.004 Hz +/- 0.01% of setting (mode 0) +/- 0.02 Hz +/- 0.01% of setting (mode 1)

**Amplitude Jitter**

Level Range	0.0 to 98.0%
Level Resolution	0.1%
Level Accuracy	+/- 0.5% of setting (Freq. = 60.0 Hz)
Frequency Range	0.0 to 300.0 Hz
Frequency Resolution	0.1 Hz
Frequency Accuracy	+/-0.02 Hz +/- 0.01% of setting
Waveforms	sine half-wave-rectified, sine full-wave-rectified, or 0 to 300 Hz band-limited noise

**Phase Jitter**

Level Range	0.0 to 90.0 degrees p-p
Level Resolution	0.1%
Level Accuracy	+/- 0.3 degrees (Freq. = 60.0 Hz)
Frequency Range	0.0 to 300.0 Hz
Frequency Resolution	0.1 Hz
Frequency Accuracy	+/- 0.02 Hz +/- 0.01% of setting

Waveforms	sine half-wave-rectified, sine full-wave-rectified, or 0 to 300 Hz band-limited noise
-----------	---

**Gain Hits**

Level Range	-20.0 to +6.0 dB
Level Resolution	0.1 dB
Level Accuracy	+/- 0.05 dB
Rise/Fall Time Range	0.2 to 990 msec
Rise/Fall Time Resolution	0.1 msec
Rise/Fall Time Accuracy	+/-0.05 msec (up to 1 msec) +/-2% of setting (> 1 msec)
Duration Range	1.875 to 20000 msec
Duration Resolution	0.625 msec
Duration Accuracy	+/- 0.05% of setting
Interval Range	0.1 to 320.0 sec
Interval Resolution	0.01 sec
Interval Accuracy	+/- 0.05% of setting
Trigger Modes	Uniform, Pseudorandom, or Single

**Phase Hits**

Level Range	0.0 to 180.0 degrees
Level Resolution	0.1 degrees
Level Accuracy	+/- 0.3 degrees
Rise/Fall Time Range	0.2 to 990 msec
Rise/Fall Time Resolution	0.1 msec

Rise/Fall Time Accuracy	+/-0.05 msec (up to 1 msec) +/-2% of setting (> 1 msec)
Duration Range	1.875 to 20000 msec
Duration Resolution	0.625 msec
Duration Accuracy	+/- 0.05% of setting
Interval Range	0.1 to 320.0 sec
Interval Resolution	0.01 sec
Interval Accuracy	+/- 0.05% of setting
Trigger Modes	Uniform, Pseudorandom, Single

**Impulse Noise**

Impulse Choices	IEEE Standard or Bipolar Pulse
Level Range	20.0 to 100 dBm (-70.0 to +10.0 dBm) (IEEE Standard) -50.0 to +10.0 dBm (Bipolar Pulse)
Level Resolution	0.1 dB (IEEE Standard) 0.1 dBm (Bipolar Pulse)
Level Accuracy	+/- 0.5 dB (IEEE Standard at 60 dBm (-30 dBm)) +/- 0.5 dB (Bipolar Pulse)
Interval Range	0.1 to 320.0 sec (IEEE Standard) 1 to 60000 msec (Bipolar Pulse)
Interval Resolution	0.01 sec (IEEE Standard) 1 msec (Bipolar Pulse)
Interval Accuracy	+/- 0.05% of setting
Duration Range	0.125 to 10 msec (Bipolar Pulse)
Duration Resolution	0.125 msec (Bipolar Pulse)
Duration Accuracy	+/- 0.05% of setting (Bipolar Pulse)
Rise/Fall Time	0.05 msec maximum (Bipolar Pulse)

Trigger Choices	Internal periodic, internal pseudorandom, internal single-shot, external continuous, or external single-shot
External Trigger Input	Schmitt trigger TTL with falling edge or active low Low level input current = - 0.4 mA max, High level input current = 20 mA max, Maximum rate = 190 Hz (bipolar), 75 Hz (IEEE)
External Trigger to Impulse Delay	Programmable from 0 to 100 msec in 0.125 msec steps (accuracy is 0.3 msec +/- .05% of setting)
External Sync Output	Open collector TTL with negative edge trigger (440 nsec typical pulse width) Low level output current = 24 mA max, High level output current = 0.1 mA max Typical sync to impulse delay = 0.25 msec + trigger to impulse delay
Calibration	C-Notched (IEEE Impulse) or Unweighted (Bipolar Pulse)
<b>Channel Interruptions</b>	
Maximum Output Signal Level	-60 dBm
Duration Range	1 to 20000 msec
Duration Resolution	0.1 msec
Duration Accuracy	+/- 0.05% of setting
Interval Range	0.1 to 320.0 sec
Interval Resolution	0.01 sec
Interval Accuracy	+/- 0.05% of setting
Rise/Fall Time	0.2 msec maximum
Trigger Modes	Uniform, Single



### Gain/Group Delay Distortion

Gain Filters	2 Independent
Group Delay Filters	2 Independent
Filter Type	Digital
Gain/Group Delay Combinations	Over 1 million

### Gain Response Characteristics

Flat  
 7 Adjustable High Band Responses  
 7 Adjustable Low Band Responses  
 3002 (Two types)  
 Bell C1, C2, C4  
 CCITT M1020, M1025, M1040  
 EIA A, B, C  
 DOD CONUS MD, MV, PD, PV  
 DOD EUROPEAN MD, MV, PD, PV  
 DOD NSB, NTB  
 JAPANESE 1-7  
 JAPANESE 4dB, 8dB, 12dB Loops  
 CCITT R.28  
 FRENCH 1-4  
 NET 20 (ETS 300 114) Line 1, Line 2  
 RITT  
 TR 50150  
 ASIA Line 1 and Line 2

### Group Delay Response Characteristics

Flat  
 7 Adjustable High Band Responses  
 7 Adjustable Low band Responses  
 3002 (Two types)  
 Bell C1, C2, C4  
 CCITT M1020, M1025  
 EIA 1-5  
 DOD CONUS MD, MV, PD, PV  
 DOD EUROPEAN MD, MV, PD, PV  
 DOD NSB, NTB  
 JAPANESE 1-7  
 CCITT R.28  
 FRENCH 1-4  
 NET 20 (ETS 300 114) Line 1, Line 2

	RITT Line 1 and Line 2 Asia Line 1 and Line 2
Transmission Time Delay of Any Gain Filters	2.12 msec
Transmission Time Delay of Group Delay Filters	Worst case Bell 3002 characteristic = 0.89 msec Worst case Bell C1 characteristic = 0.88 msec Worst case Bell C2 characteristic = 0.92 msec Worst case Bell C4 characteristic = 1.61 msec  SEG FA-1445 characteristic emulation = 1.53 msec  Worst case CCITT M1020 characteristic = 0.92 msec Worst case CCITT M1025 characteristic = 0.81 msec
AD,S03=0:	EIA 1 characteristic = 2.57 msec EIA 2 characteristic = 1.47 msec EIA 3 characteristic = 1.19 msec EIA 4 characteristic = 0.52 msec EIA 5 characteristic = 1.21 msec
AD,S03=1:	EIA 1 characteristic = 2.64 msec EIA 2 characteristic = 1.54 msec EIA 3 characteristic = 1.33 msec EIA 4 characteristic = 0.76 msec EIA 5 characteristic = 1.23 msec  CONUS Mid Data characteristic = 2.08 msec CONUS Mid Voice characteristic = 1.22 msec CONUS Poor Data characteristic = 2.08 msec CONUS Poor Voice characteristic = 0.74 msec  European Mid Data characteristic = 2.15 msec European Poor Data characteristic = 2.15 msec European Mid Voice characteristic = 1.58 msec European Poor Voice characteristic = 1.22 msec NSB characteristic = 0.70 msec NTB characteristic = 0.71 msec JPN 1 link characteristic = 1.88 msec JPN 2 link characteristic = 1.42 msec JPN 3 link characteristic = 1.43 msec JPN 4 link characteristic = 1.31 msec JPN 5 link characteristic = 1.48 msec

JPN 6 link characteristic = 1.25 msec  
 JPN 7 link characteristic = 0.91 msec  
 R 28 characteristic = 1.39 msec  
 Low frequency characteristic #1 = 2.29 msec  
 Low frequency characteristic #2 = 1.96 msec  
 Low frequency characteristic #3 = 1.81 msec  
 Low frequency characteristic #4 = 1.77 msec  
 Low frequency characteristic #5 = 1.60 msec  
 Low frequency characteristic #6 = 1.47 msec  
 Low frequency characteristic #7 = 1.31 msec

High frequency characteristic #1 = 2.10 sec  
 High frequency characteristic #2 = 1.97 sec  
 High frequency characteristic #3 = 1.87 msec  
 High frequency characteristic #4 = 1.71 msec  
 High frequency characteristic #5 = 1.53 msec  
 High frequency characteristic #6 = 1.63 msec  
 High frequency characteristic #7 = 1.64 msec

French line 1 characteristic = 2.64 msec  
 French line 2 characteristic = 2.51 msec  
 French line 3 characteristic = 1.67 msec  
 French line 4 characteristic = 1.73 msec

NET 20 Test Channel 1 characteristic = 0.30 msec

**Satellite Delay**

Range 0 to 1279.875 msec  
 (relative to background delay)

Resolution 125  $\mu$ sec

Accuracy +/- 0.01%

**Echo Attenuators (Near A, Far A, Near B, Far B)**

Level -10.0 to +40.0 dB

Resolution 0.1 dB

Accuracy +/- 0.2 dB @ -10.0 dB  
 +/- 0.3 dB @ -40.0 dBm

Residual Near Echo Delay < 0.2 msec

**Auxiliary Echo**

Type	Listener, Intermediate Talker
Attenuation	0.0 to 40.0 dB
Attenuation Resolution	0.1 dB
Attenuation Accuracy	+/- 0.2 dB @ -10.0 dB +/- 0.3 dB @ -40.0 dBm
Delay Range	0 to 875.0 msec (Configurations 0 and 1) 0 to 290.0 msec (Configuration 2)
Delay Resolution	125 $\mu$ sec
Delay Accuracy	+/- 0.01%
Residual Delay	5.0 msec +/- 0.1 msec (Configurations 0 and 1) 1.6 msec +/- 0.1 msec (Configuration 2)

**5.5. PCM/ADPCM Module (Option)**

Number of Links Simulated	0-4
Sampling Rate	8.0 kHz
PCM Coding for Each Link	None (analog bypass), mu-law, or A-law
Link Rates	64 kbps PCM 40 kbps ADPCM (CCITT G.723, same as ANSI T1Y1/87-040) 32 kbps ADPCM (CCITT G.721, same as ANSI T1.301-1987) 24 kbps ADPCM (CCITT G.723, same as ANSI T1Y1/87-040) 16 kbps ADPCM
PCM Robbed Bit Signaling	Least significant bit at every sixth frame (8 bits per frame) 16 patterns from 0000 to 1111
Random Error Injection Rates	Off, 2E-20, 2E-17, 2E-13, 2E-10, 2E-7, or 2E-3
Random Error Distribution	Poisson
Gain/Delay Characteristics	See figures 5-95 to 5-102

## 5.6. Extended PCM/ADPCM Module (Option)

Number of Links Simulated	0-4 (0-2 in each direction)
Sampling Rate	8.0 kHz
PCM Coding for Each Link	None (analog bypass), mu-law, or A-law
Link Rates	64 kbps PCM 32 kbps ADPCM (ECI and OKI custom ADPCM) 24 kbps ADPCM (OKI custom ADPCM)
Frame Slips	Positive or Negative, up to 15 consecutive (in one direction), exhaustive (only in one direction) or cyclic buffer triggerable
Random Error Distribution	Poisson or Regular (non-random)

## 5.7. Cellular Audio Processor (CAP) Module Option

Cellular to PSTN Audio Performance:	Meets requirements of EIA/IS-19-B, EIA/IS-20A, EIA/TIA-553, and EIA/TIA/IS-55 cellular standards
PSTN to Cellular Audio Performance:	Meets requirements of EIA/IS-19-B, EIA/IS-20A, EIA/TIA-553, and EIA/TIA/IS-55 cellular standards
Test Topology:	GT Cellular or Tandem
Cellular to PSTN Characteristics (GT Cellular Topology):	De-emphasis Expansion
PSTN to Cellular Characteristics (GT Cellular Topology):	Compression De-emphasis Limiter Post-Limiter Filter
Cellular to PSTN Characteristics (Tandem Topology):	Compression De-emphasis Limiter Post-Limiter Filter De-emphasis Expansion
PSTN to Cellular Characteristics (Tandem Topology):	Compression De-emphasis Limiter Post-Limiter Filter De-emphasis Expansion
Compressor Reference Level:	-27 dBm nominal
Expander Reference Level:	-27 dBm nominal

## 5.8. Basic Central Office Emulation

### General

Operating Modes	2-wire switched (loop start), 2-wire auto-switched (loop start), 2-wire private-line, or 4-wire private-line
Nominal Input Impedance	600 ohms +/- 30 ohms
Nominal Output Impedance	600 ohms +/- 30 ohms
Internal Hybrid Balance Impedance	604 ohms +/- 6 ohms
Transhybrid Loss	40 dB minimum (300 Hz to 3500 Hz) (2-wire = Balance Impedance)

### Constant Current Feed Generator (Switched Line Modes)

Off Hook Detection Current	7 mA +/- 1.5 mA Threshold
Current Source Range	10 to 126 mA (Station A and B independently controlled)
Current Source Resolution	2 mA
Current Source Accuracy	+/- 2.0 mA
Current Source Maximum	1800 ohms @ 20 mA
Allowable Off Hook	900 ohms @ 40 mA
Tip to Ring	600 ohms @ 60 mA
DC Resistance	400 ohms @ 80 mA 300 ohms @ 100 mA 225 ohms @ 120 mA
On Hook Tip to Ring (45 Volt Battery)	46 V typical
On Hook Tip to Ring (54 Volt Battery)	51 V typical



**Constant Voltage Feed Generator (Switched Line Modes)**

Voltage Source Choices	45 V or 54 V
Voltage Source Accuracy	+/- 2.0 V
Loop Resistance Choices	Low or High (Voltage Source)
On Hook Tip to Ring	43.5 V typical (45 Volt Battery)
On Hook Tip to Ring	52 V typical (54 Volt Battery)

**Ringling Generator**

Level Range (Open Circuit)	1 to 100 Vrms (Superimposed upon DC Bias Voltage)
Level Resolution	1 Volts
Level Accuracy	+/- 5.0%
AC Source Impedance	2100 ohms typical
Frequency Range	14.0 to 120.0 Hz
Frequency Resolution	0.1 Hz
Frequency Accuracy	+/- 0.02 Hz +/- 0.1%
Cadence	Up to 3 on/off stages
On Time Range	0 to 60,000 msec
On Time Resolution	50 msec
On Time Accuracy	+/- 0.05%
Off Time Range	0 to 60,000 msec
Off Time Resolution	50 msec
Off Time Accuracy	+/- 0.05%
DC Bias (45 Volt Battery)	45 V
DC Bias	54 V

(54 Volt Battery)

DC Source Impedance 1360 ohms typical

Ring Trip DC Current Detection Threshold 5 mA +/- 1.5 mA

**Signaling Tones**

Supported Tones Primary Dial Tone  
Secondary Dial Tone  
Call in Progress Tone  
Busy  
Ringback

Tone Delay Range 1 to 60,000 or 1 to 60,000 msec  
(Relative to Central Office Setup Delay)

Tone Delay Resolution 1.0 msec

Tone Delay Accuracy +/- 0.05%

Tone Cadence 3 on/off stages

On Time Range 0 to 60,000 or 0 to 60,000 msec

On Time Resolution 50 msec

On Time Accuracy +/- 0.05%

Off Time Range 0 to 60,000 or 0 to 60,000 msec

Off Time Resolution 50 msec

Off Time Accuracy +/- 0.05%

Level Range 0 to -50.0 dBm

Level Resolution 0.1 dB

Level Accuracy +/- 0.5 dB (300 - 3000 Hz)

Frequency Range 100.0 to 3400.0 Hz

Frequency Resolution 0.1 Hz

Frequency Accuracy +/- 0.02 Hz +/- 0.1%

**Touch Tone Detection Limits**

Input Level Range 0.0 to -25.0 dBm

Max. Invalid Tone Duration 20.0 msec

Min. Interdigit Pause 40.0 msec

Max. Acceptable Dropout 20.0 msec

**Dial Pulse Detection Limits**

Interval Range (Make and Break) 10 to 90 msec

Interval Resolution 1 msec

Interval Accuracy +/- 5 msec (at 24 mA loop current)

Min. Interdigit Pause 300.0 msec

**Telephone Number**

Station A 1 to 15 digits

Station B 1 to 15 digits

**Switching Delay**

Range 1 to 60,000 msec

Resolution 1.0 msec

Accuracy +/- 0.05% +/- 1.0 msec

**Dial Tone Delay**

Range 1 to 60,000 msec

Resolution 1.0 msec

Accuracy +/- 0.05% +/- 1.0 msec

**On Hook Delay**

Range 1 to 255 msec

Resolution 1.0 msec

Accuracy +/- 1.0 msec

### **Station Set Interfaces**

(Type RJ45S jacks located on front and rear panels)

Pin Assignments: 4W configuration	Pin 1: Transmit Signal (R1 - Input to Emulator) Pin 2: Transmit Signal (T1 - Input to Emulator) Pin 3: TEK5 Loopback Mode Indicator Pin 4: No Connect Pin 5: No Connect Pin 6: TEK6 Loopback Mode Indicator Pin 7: Receive Signal (T - Output from Emulator) Pin 8: Receive Signal (R - Output from Emulator)
--------------------------------------	--

Pin Assignments: 2W configuration	Pin 1: No Connect Pin 2: No Connect Pin 3: No Connect Pin 4: Ring Pin 5: Tip Pin 6: No Connect Pin 7: Program Resistor (866 ohms) Pin 8: Program Resistor (866 ohms)
--------------------------------------	---

### **External B Expansion A Path Interface (2-Wire Modes Only)**

Pin T1: Path Input (Tip)  
Pin R1: Path Input (Ring)  
Pin T2: Path Output (Tip)  
Pin R2: Path Output (Ring)  
Pin GND: Reserved

### **Hybrid Balance Network Interface (2-Wire Modes Only)**

Pin A1: Node 1 of Station A Network  
Pin A2: Node 2 of Station A Network  
Pin B1: Node 1 of Station B Network  
Pin B2: Node 2 of Station B Network

## 5.9. Remote Control Interfaces

### Standard Interfaces

Control Ports (GPIB) RS-232C (DTE) and IEEE-488

Auxiliary Port RS-232C (DCE)

### Serial Control Port

Bit Rates 1200, 2400, 4800, or 9600 bps

Mode asynchronous

Word Length 7 bits

Parity odd

Stop Bits 1

### RS-232C (DTE) Control Port Pin Assignments

<b>Pin</b>	<b>Function</b>
1 GND	Protective ground
2 TxD	Transmit data output
3 RxD	Receive data input
4 RTS	Request-to-send output
5 CTS	Clear-to-send input
6 DSR	Data set ready input (not checked)
7 GND	Signal ground
20 DTR	Data terminal ready output (active)

**RS-232C (DCE) Auxiliary Port Pin Assignments**

<b>Pin</b>	<b>Function</b>
1 GND	Protective ground
2 TxD	Transmit data input
3 RxD	Receive data output
4 RTS	Request-to-send input
5 CTS	Clear-to-send output
6 DSR	Data set ready output (not checked)
7 GND	Signal ground
20 DTR	Data terminal ready input (active)

**GPIB Control Port Pin Assignments**

<b>Pin</b>	<b>Function</b>
1	DIO1
2	DIO2
3	DIO3
4	DIO4
5	EOI
6	DAV
7	NRFD
8	NDAC
9	IFC
10	SRQ
11	ATN
12	FRAME GND
13	DIO5
14	DIO6
15	DIO7
16	DIO8
17	REN
18	SIGNAL GND
19	SIGNAL GND
20	SIGNAL GND
21	SIGNAL GND
22	SIGNAL GND
23	SIGNAL GND
24	SIGNAL GND

### 5.10. Frequency Response Characteristics

Gain/Delay response curves (Figure 5-1 through Figure 5-117) for the Series II unit are on the following pages.

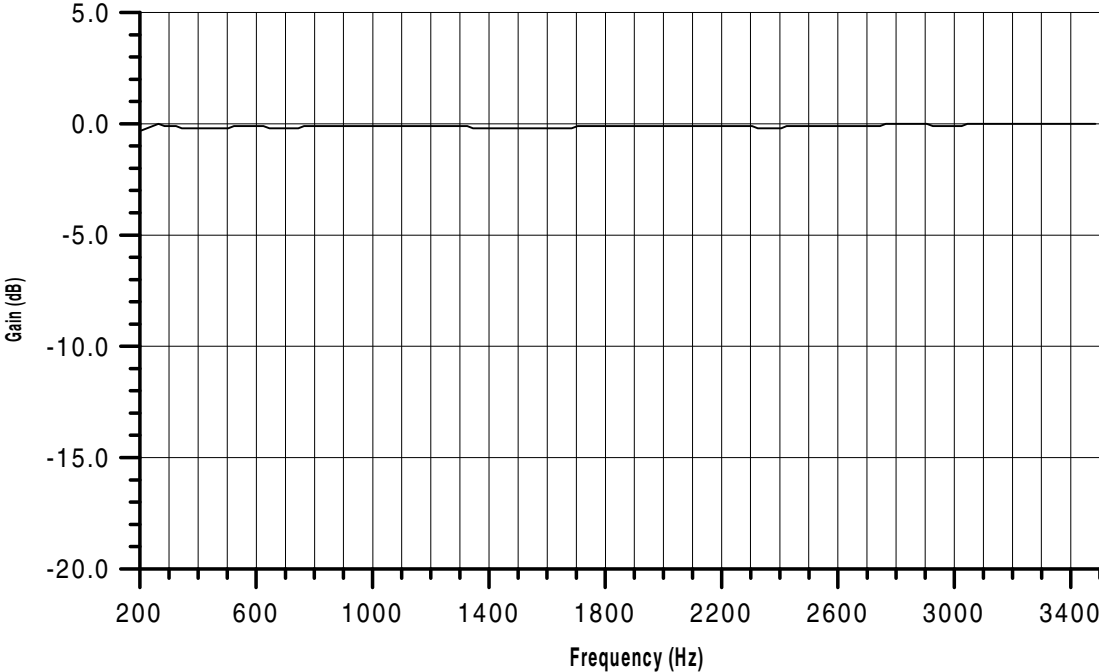

**Figure 5-1. TAS "Enhanced" Flat Gain Response**

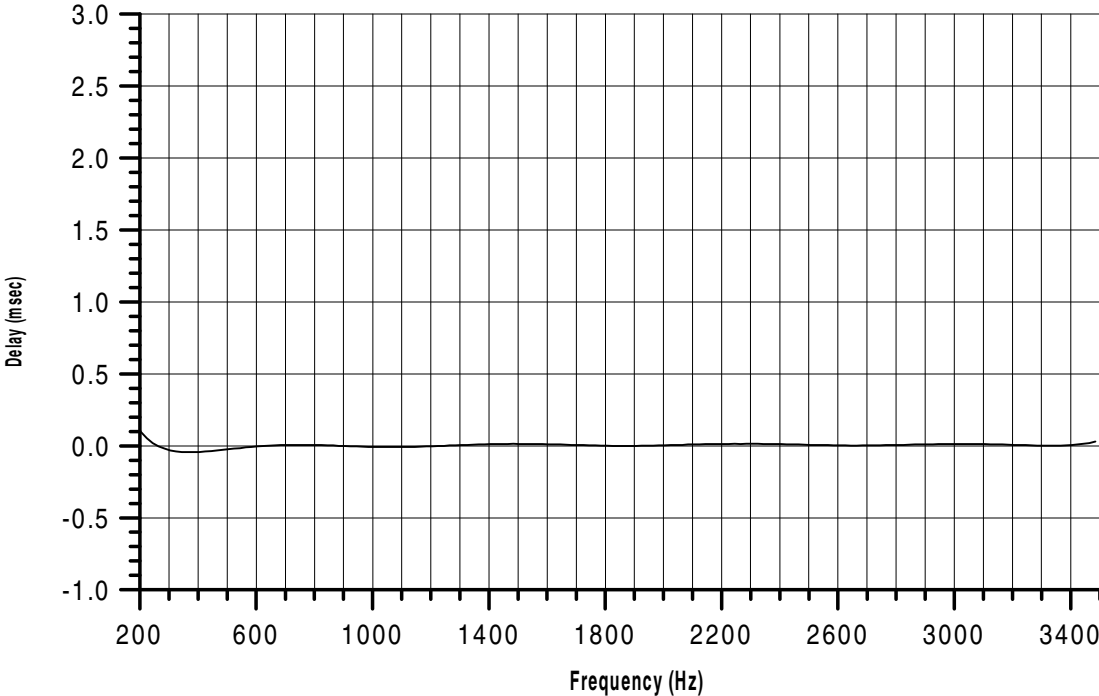

**Figure 5-2. TAS "Enhanced" Flat Delay Response**

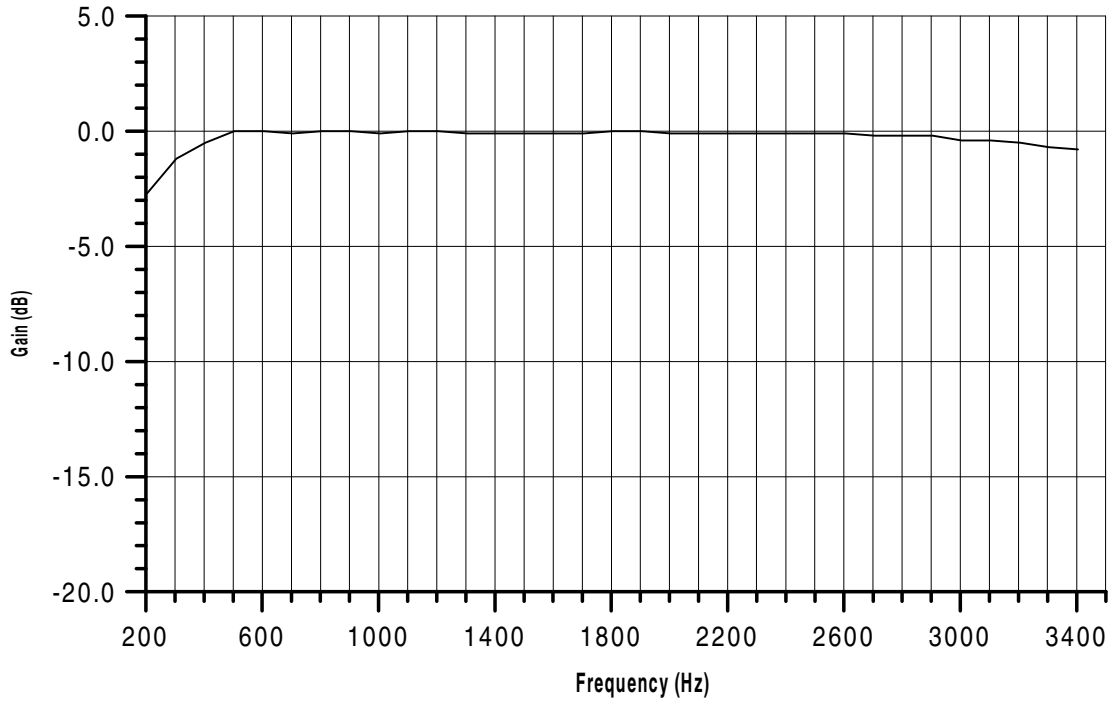

Figure 5-3. TAS "1010 Compatible" Flat Gain Response

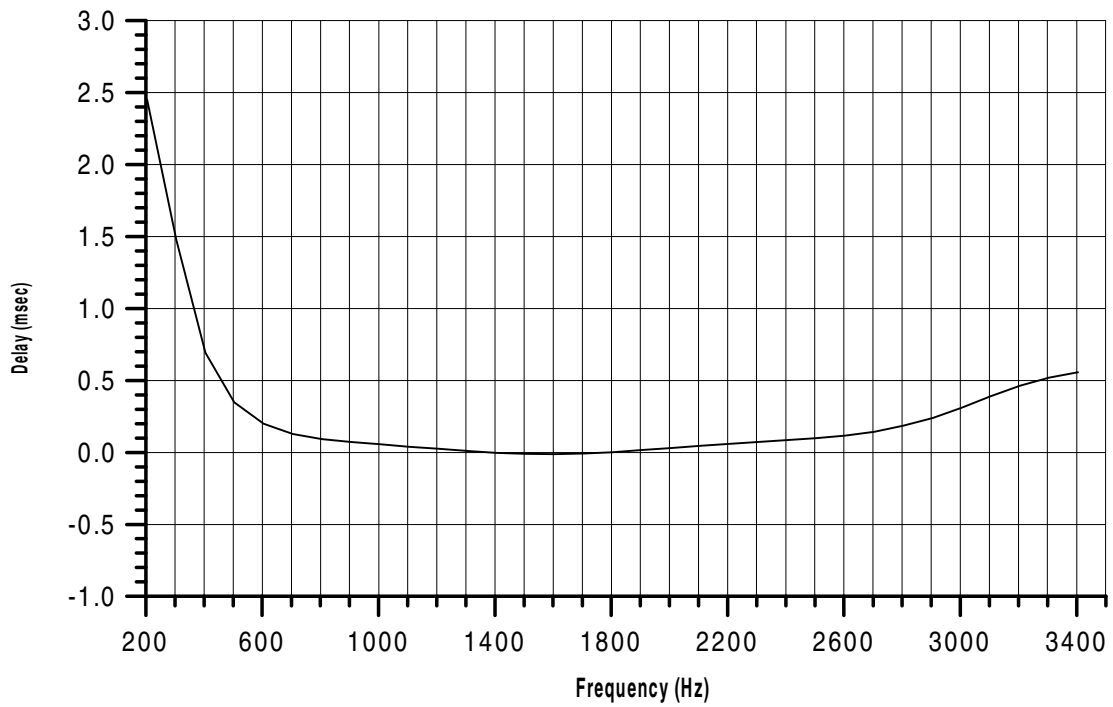

Figure 5-4. TAS "1010 Compatible" Flat Delay Response



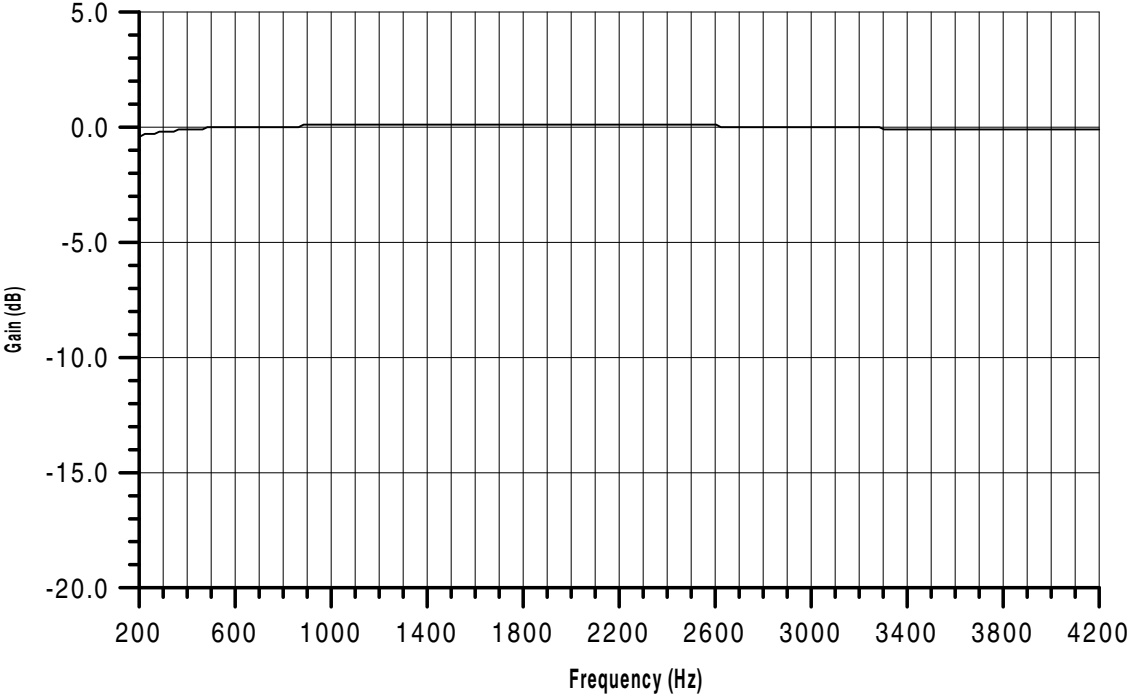

Figure 5-5. TAS Flat Gain (NET 20 Line 2) Response

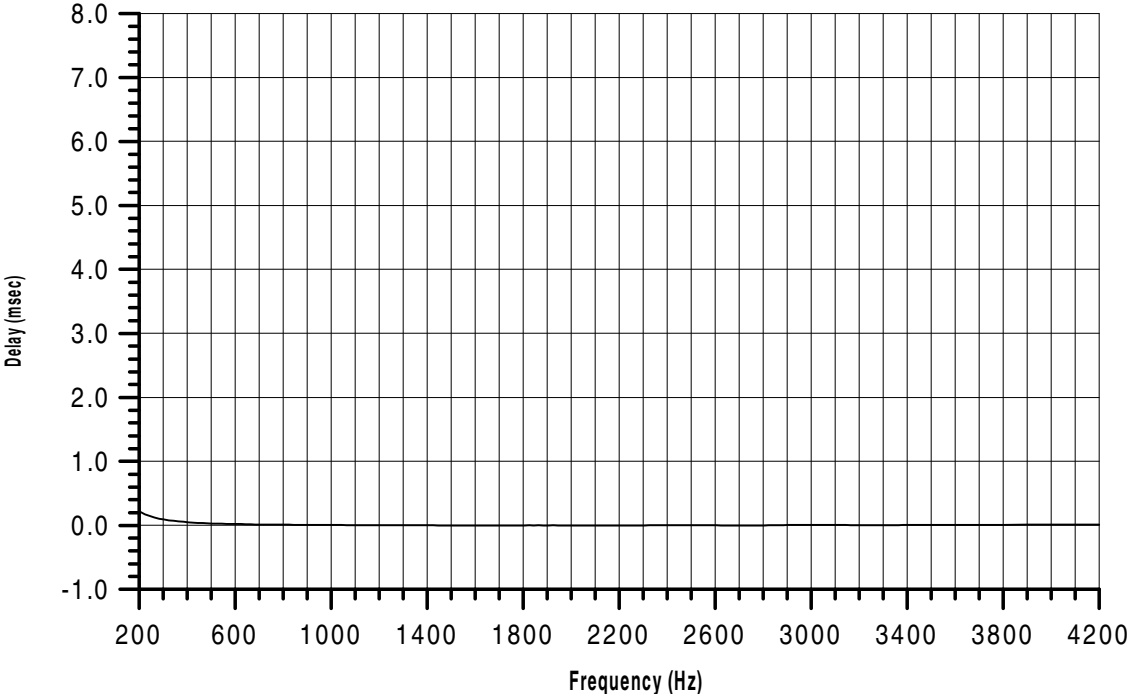

Figure 5-6. TAS Flat Delay (NET 20 Line 2) Response

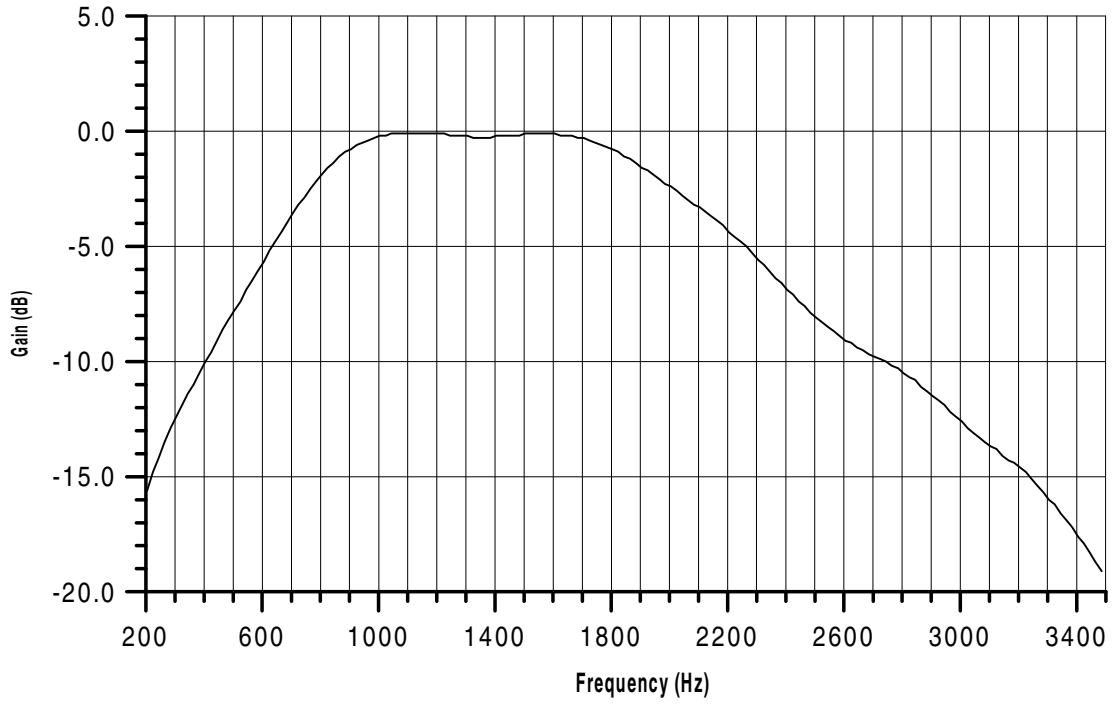

Figure 5-7. TAS Worst Case Bell 3002 Gain

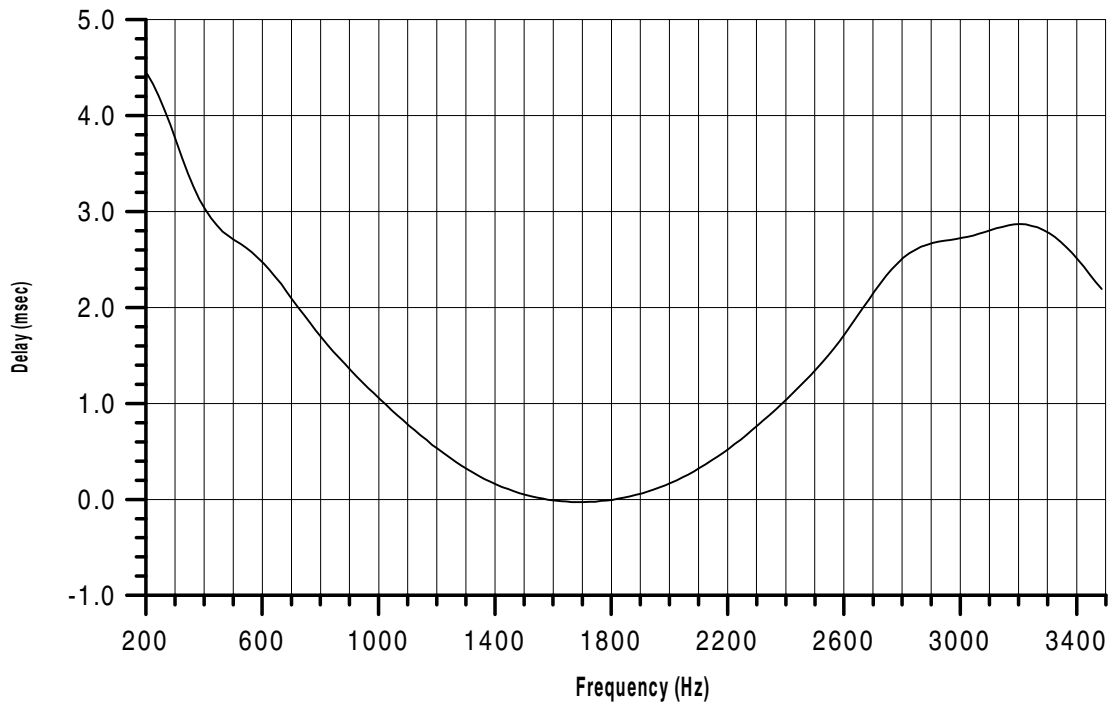

Figure 5-8. TAS Worst Case Bell 3002 Delay

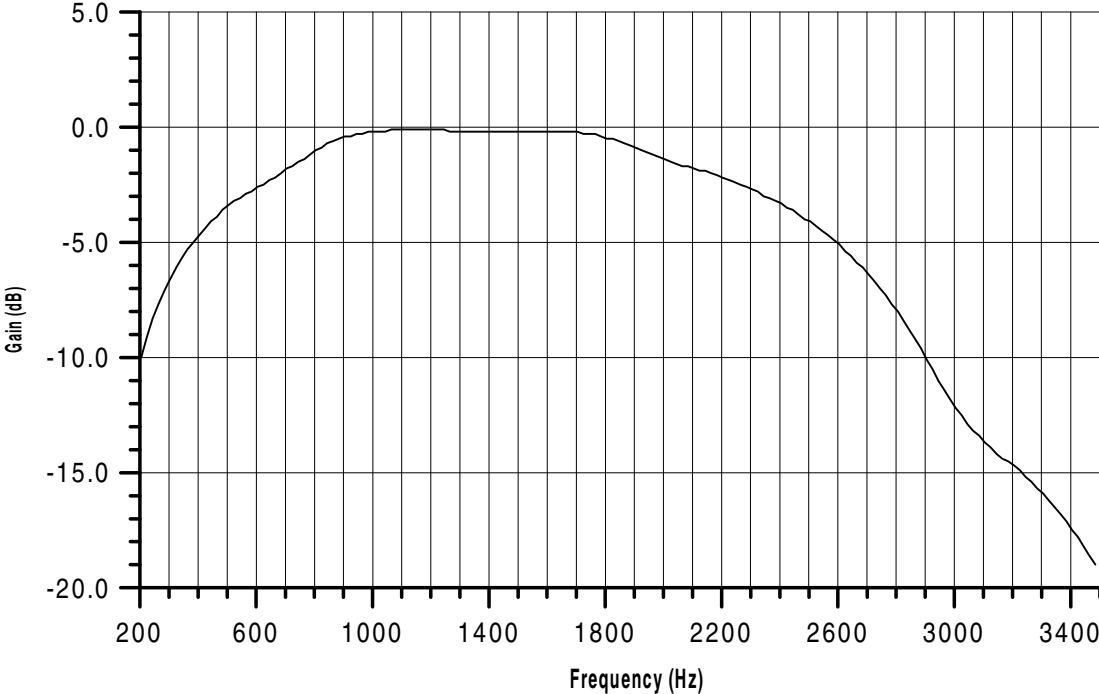

Figure 5-9. TAS Worst Case Bell C1 Gain

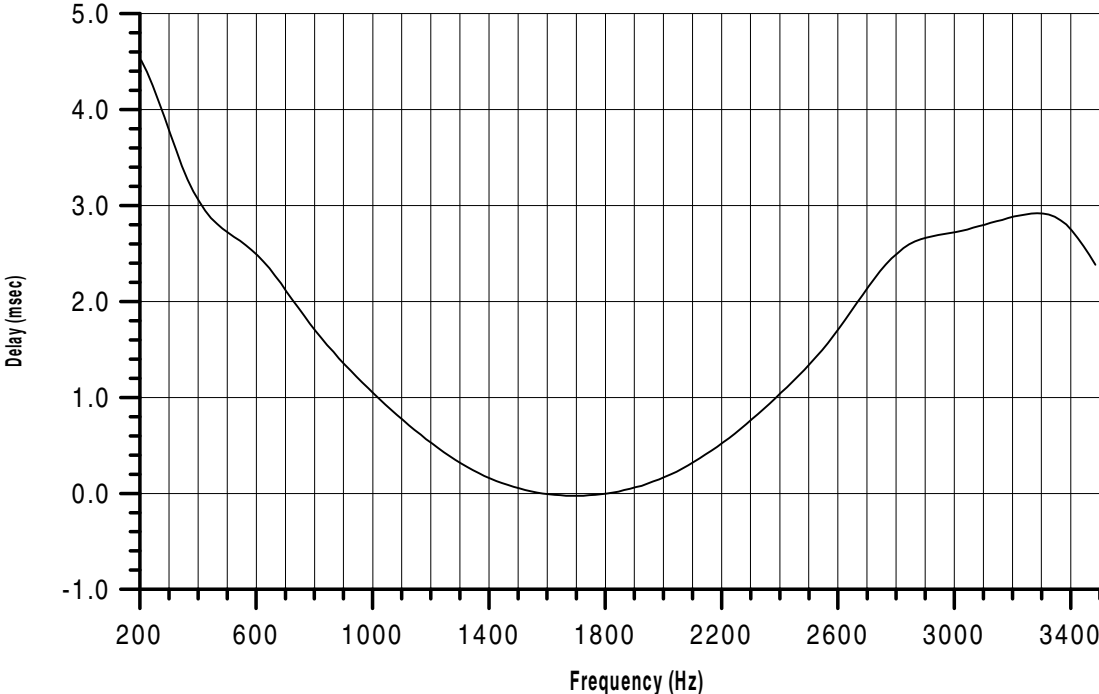

Figure 5-10. TAS Worst Case Bell C1 Delay

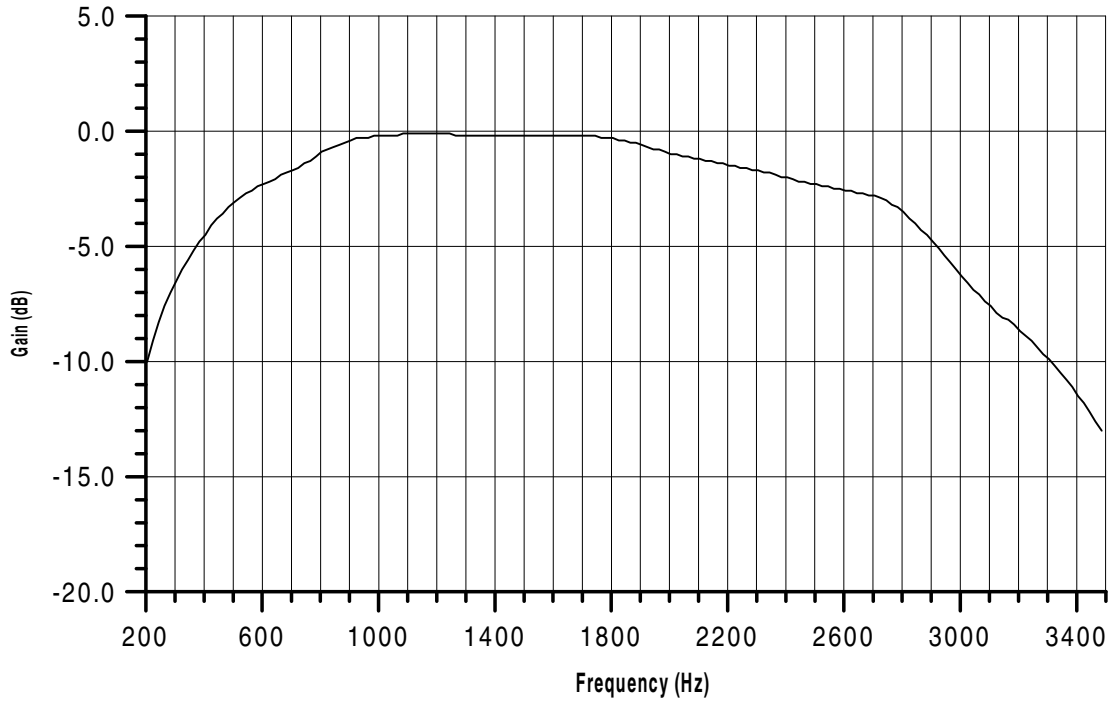

Figure 5-11. TAS Worst Case Bell C2 Gain

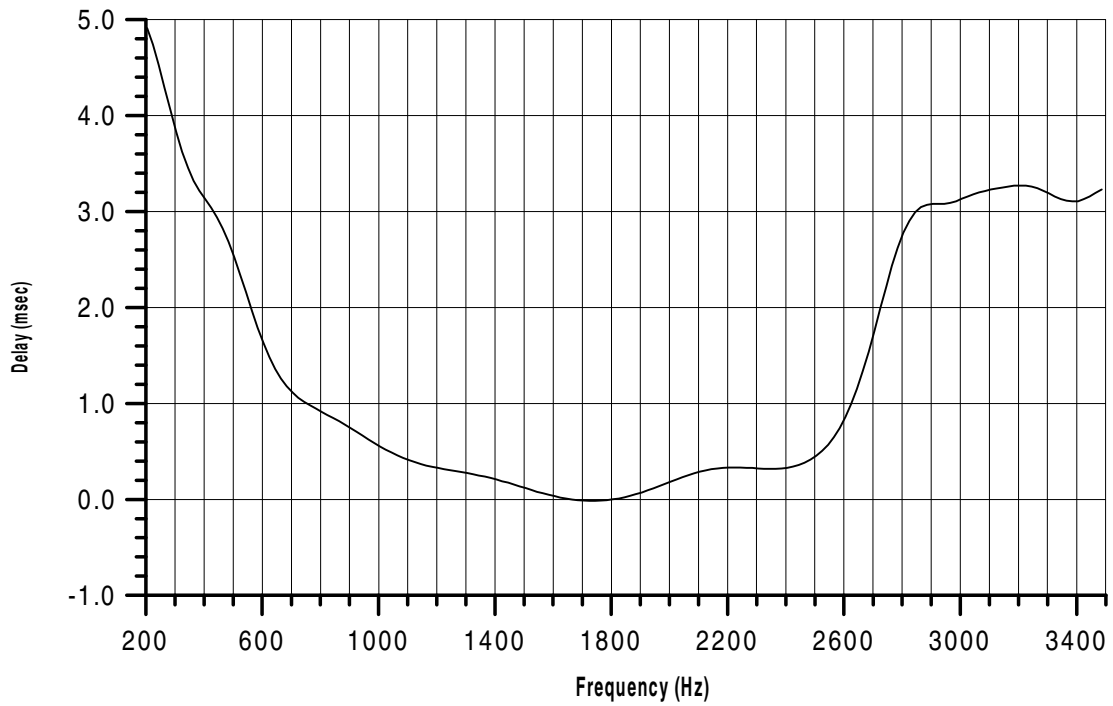

Figure 5-12. TAS Worst Case Bell C2 Delay

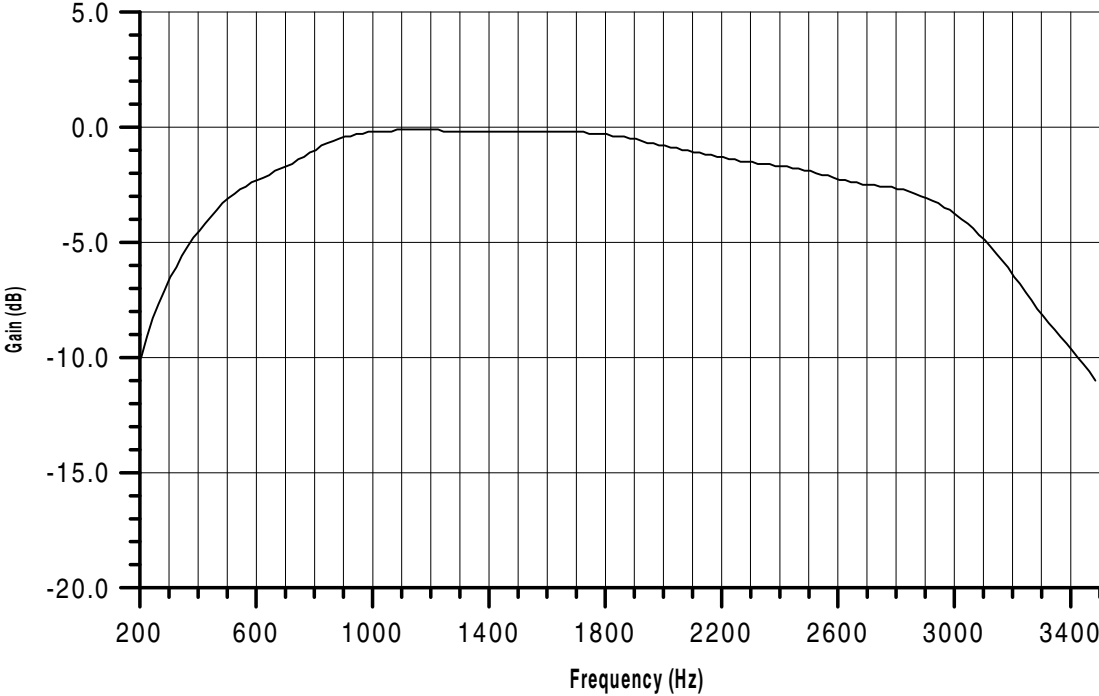

Figure 5-13. TAS Worst Case Bell C4 Gain

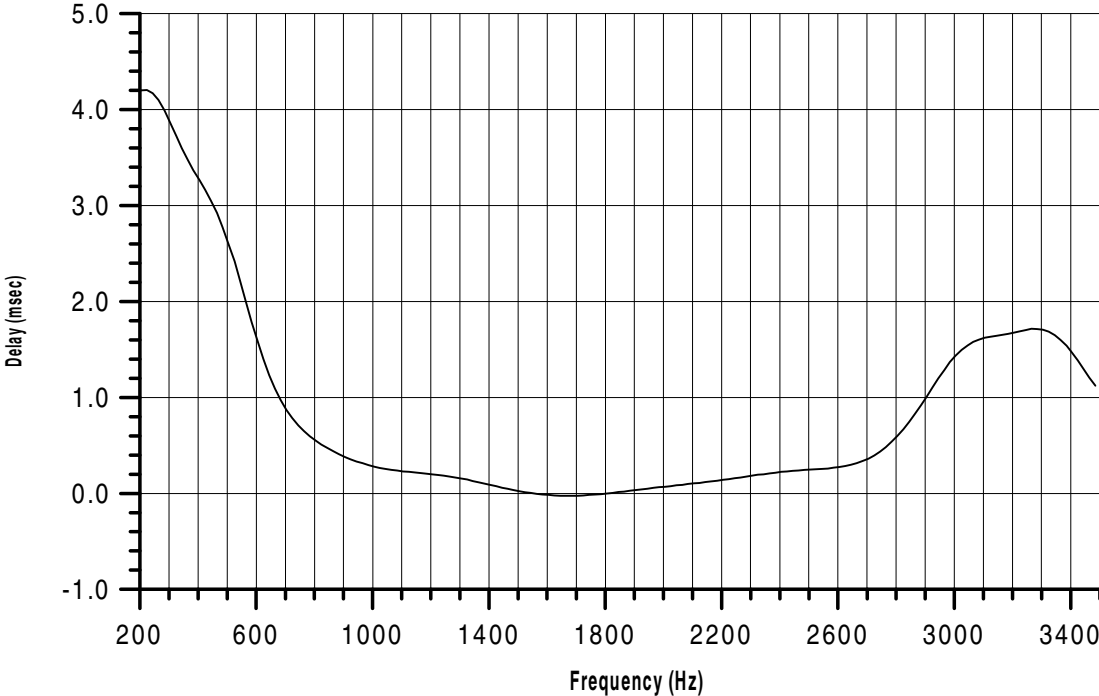

Figure 5-14. TAS Worst Case Bell C4 Delay

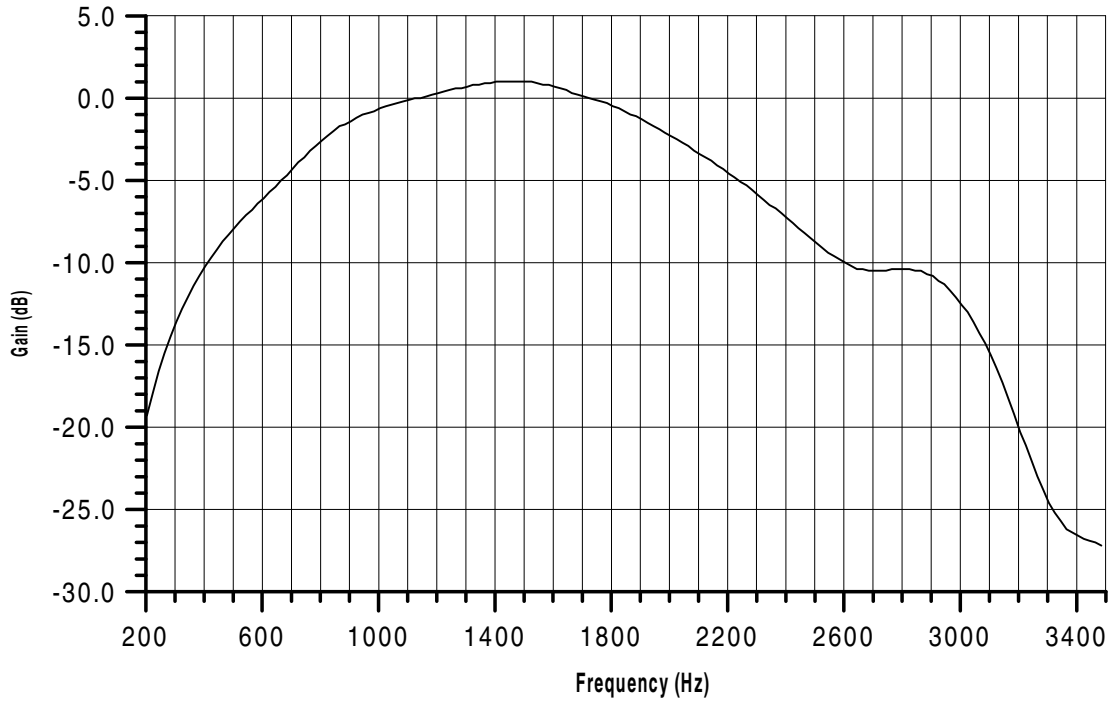

Figure 5-15. TAS Seg FA-1445 Emulation Gain

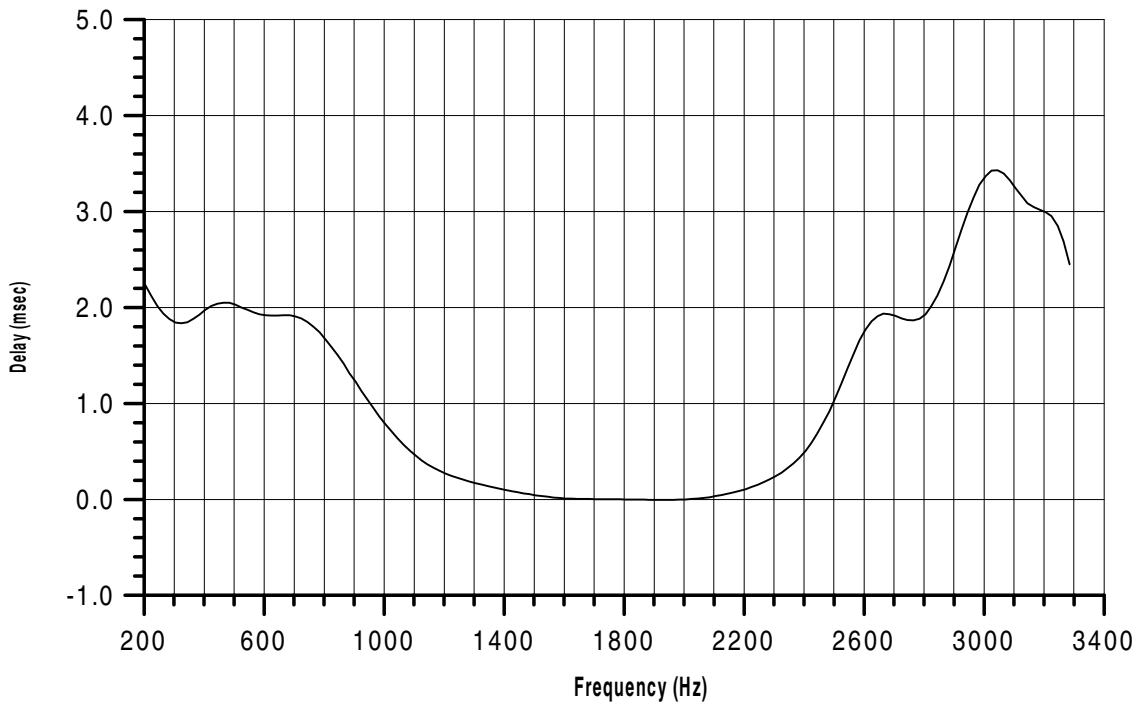

Figure 5-16. TAS Seg FA-1445 Emulation Delay

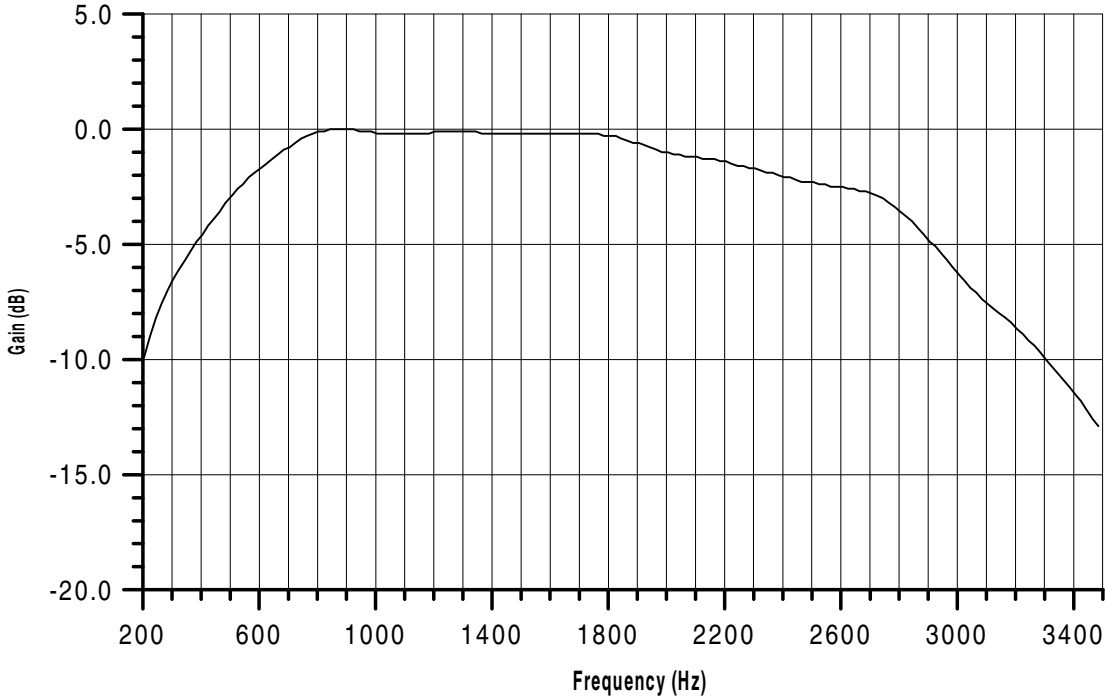

Figure 5-17. TAS Worst Case CCITT M1020 Gain

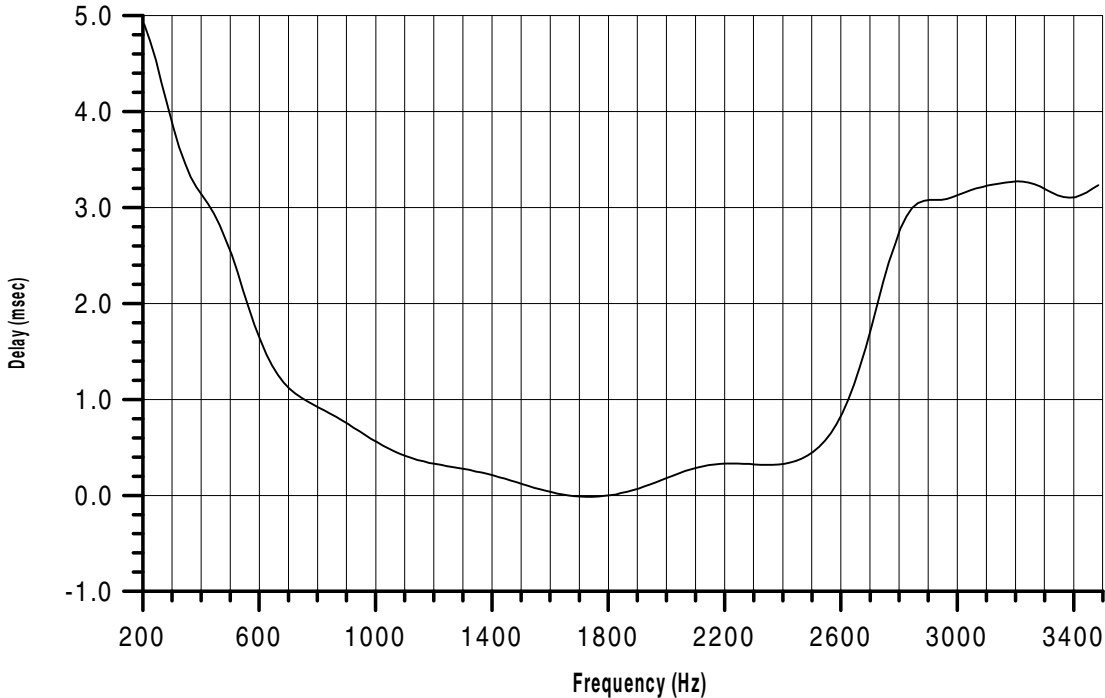

Figure 5-18. TAS Worst Case CCITT M1020 Delay

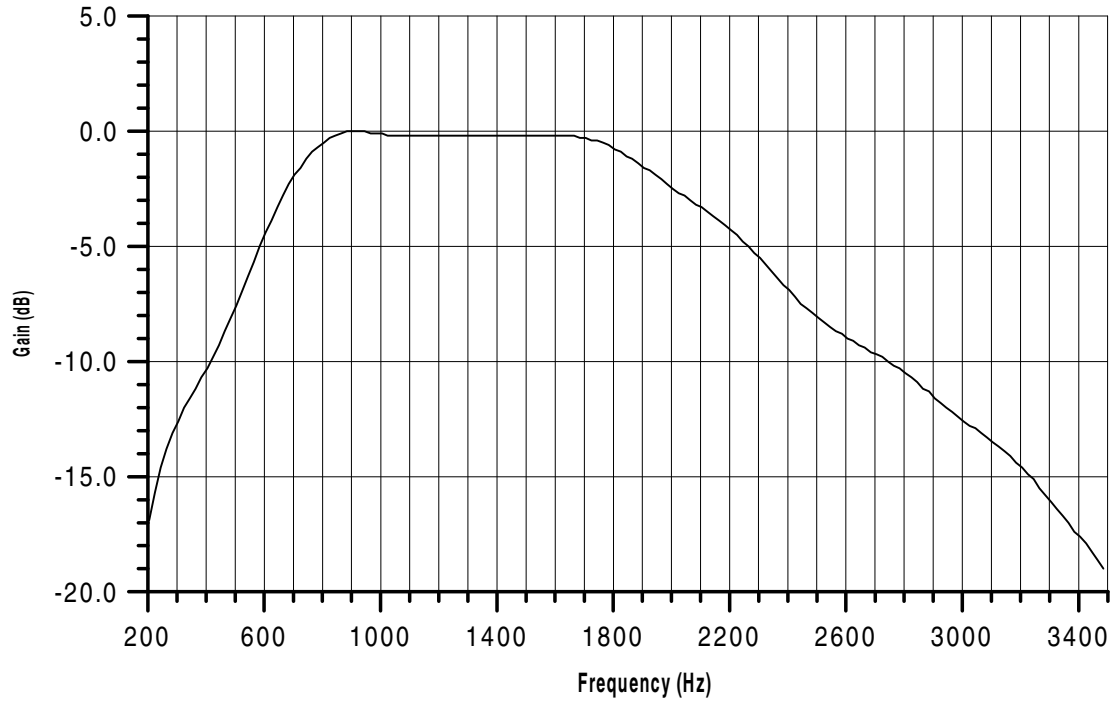

Figure 5-19. TAS Worst Case CCITT M1025 Gain

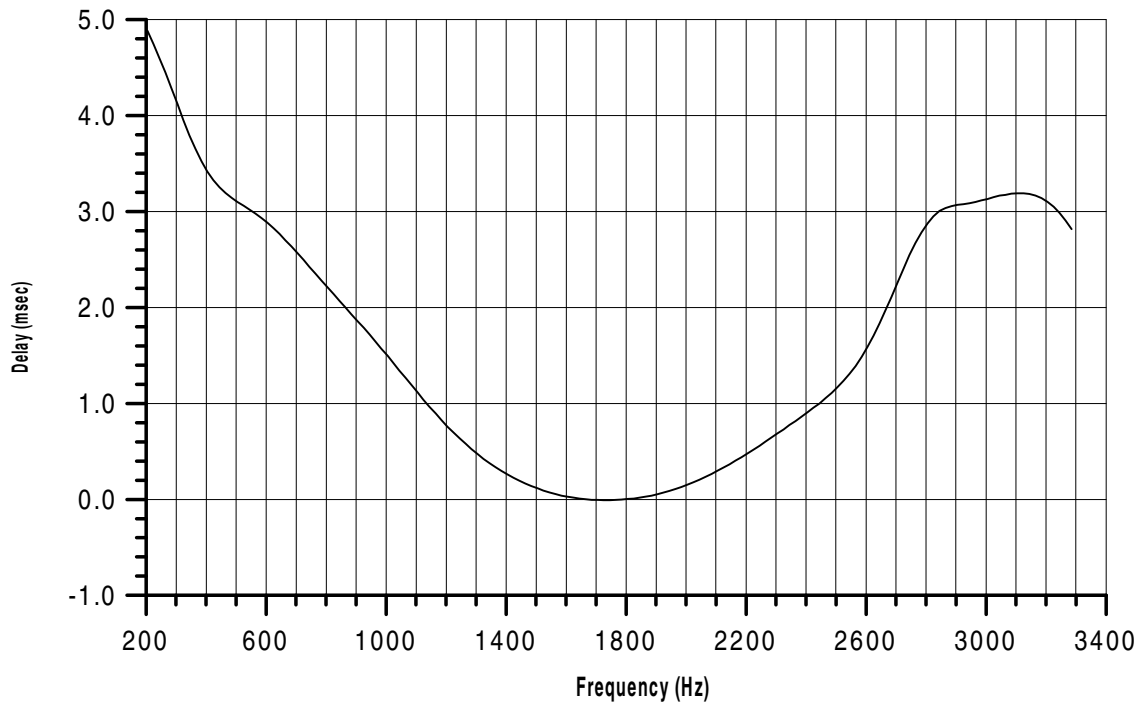

Figure 5-20. TAS Worst Case CCITT M1025 Delay



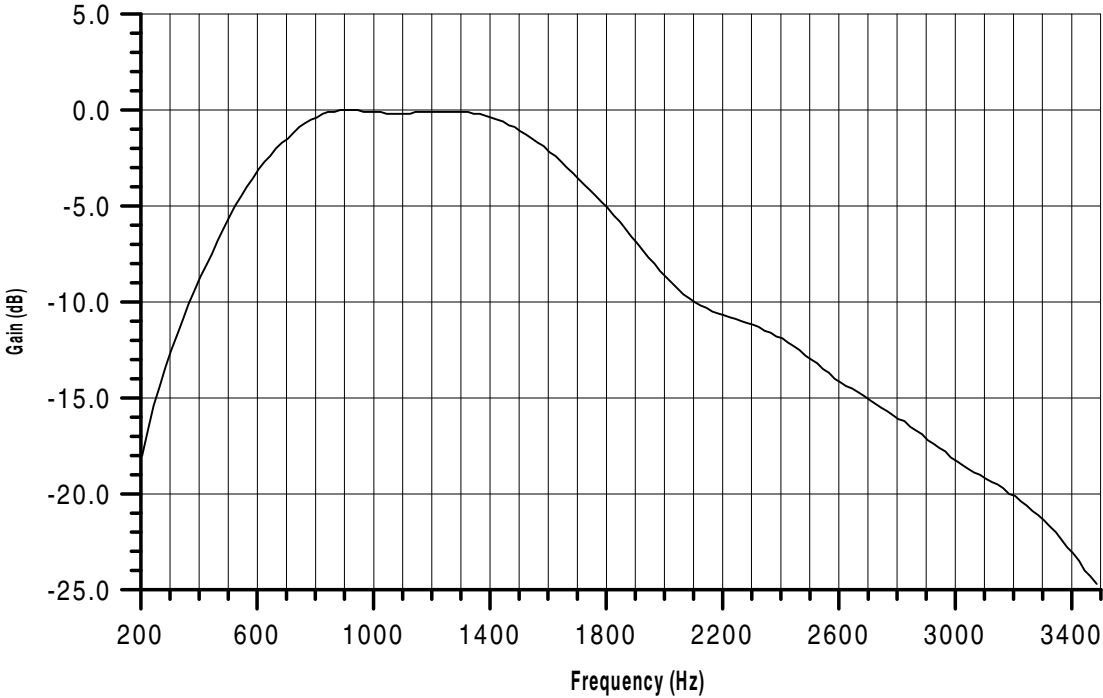

Figure 5-21. TAS Worst Case CCITT M1040 Gain

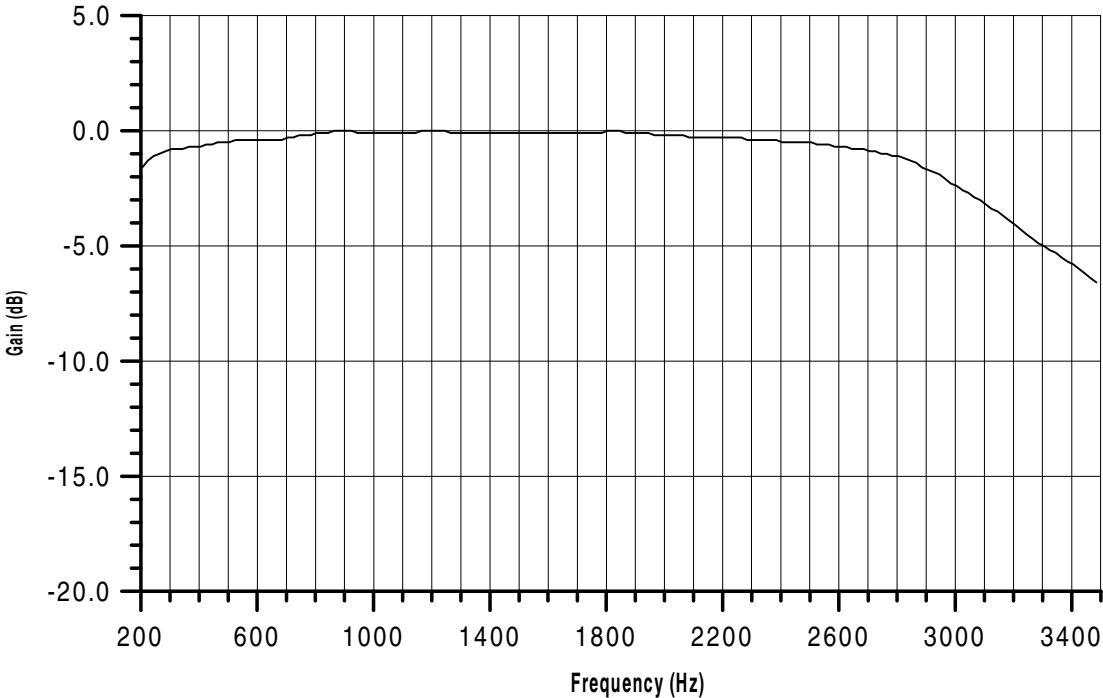
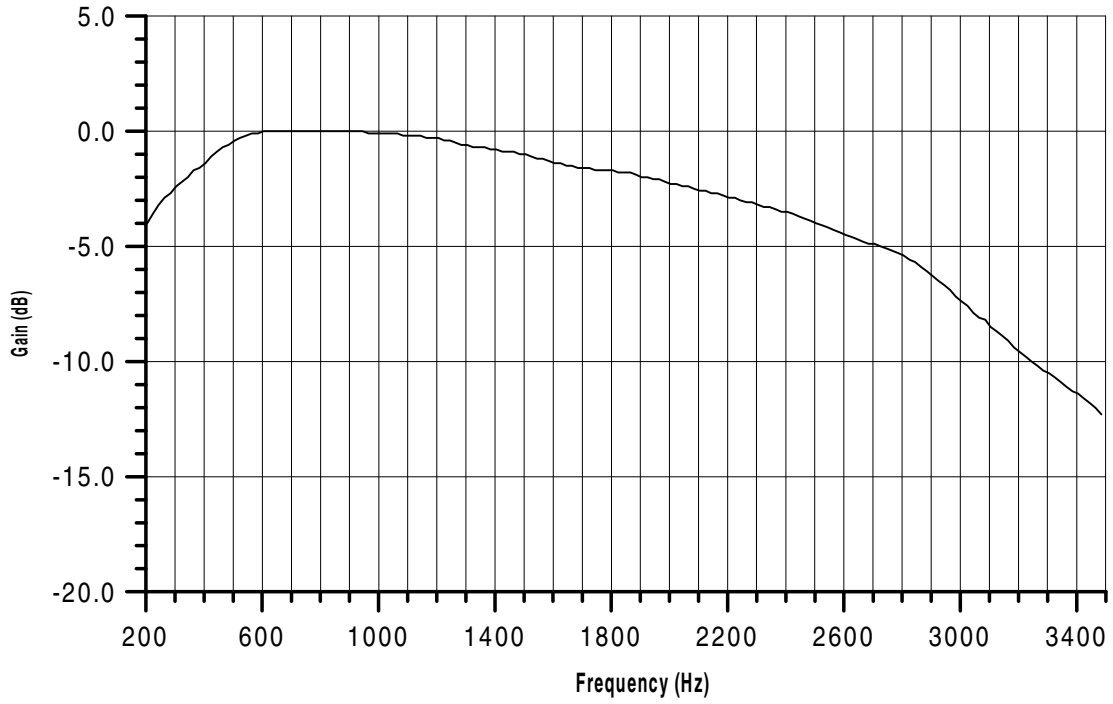
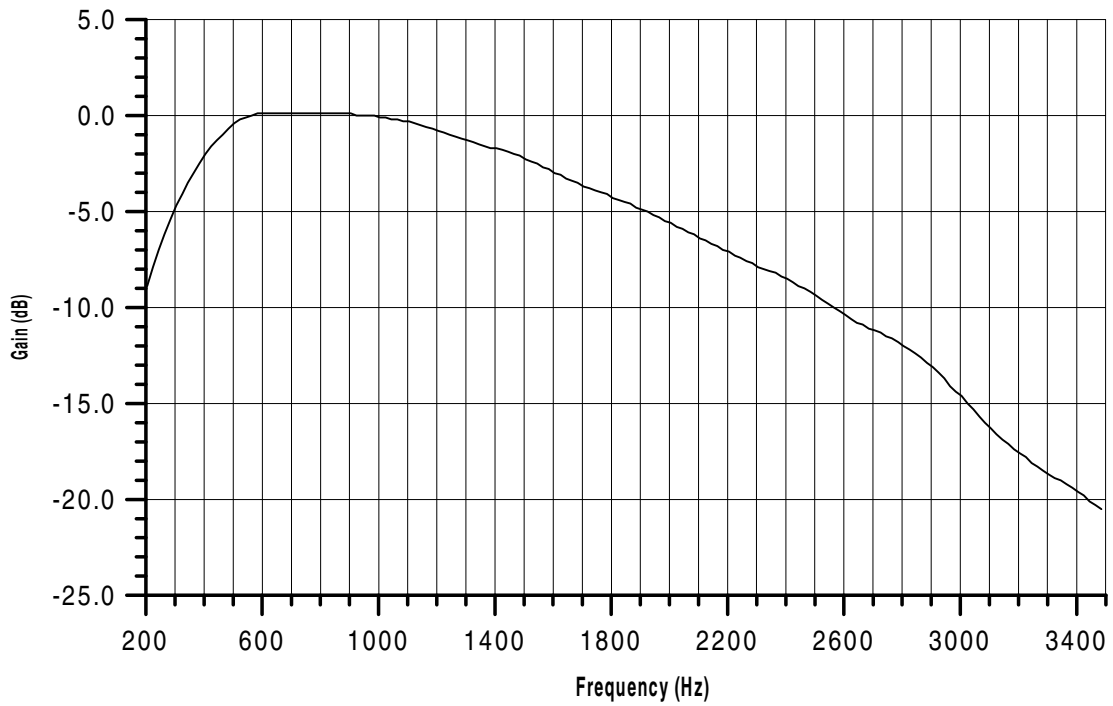

Figure 5-22. TAS "Enhanced" EIA A Gain Characteristics



**Figure 5-23. TAS "Enhanced" EIA B Gain Characteristics**



**Figure 5-24. TAS "Enhanced" EIA C Gain Characteristic**

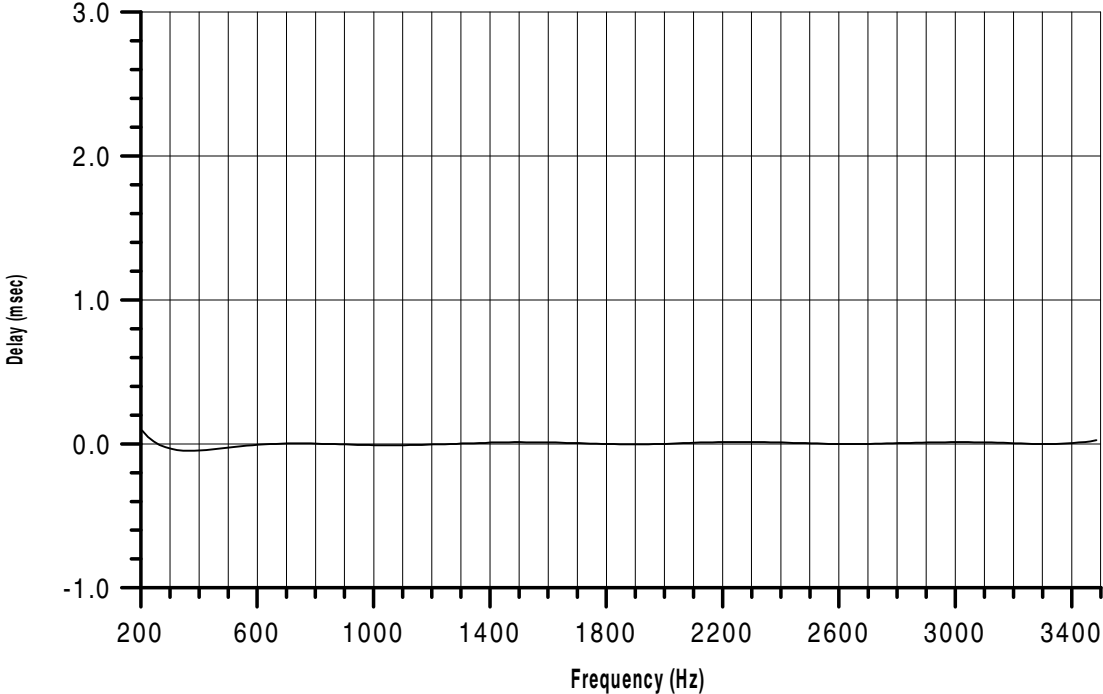

Figure 5-25. TAS "Enhanced" EIA 1 Delay Characteristic

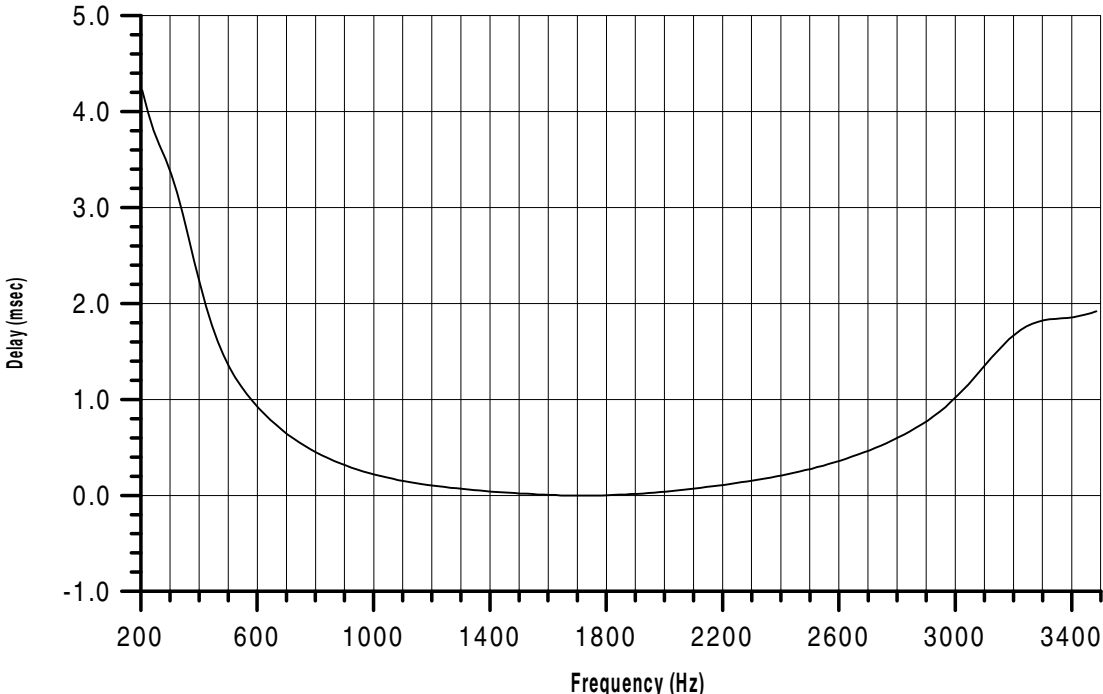

Figure 5-26. TAS "Enhanced" EIA 2 Delay Characteristic

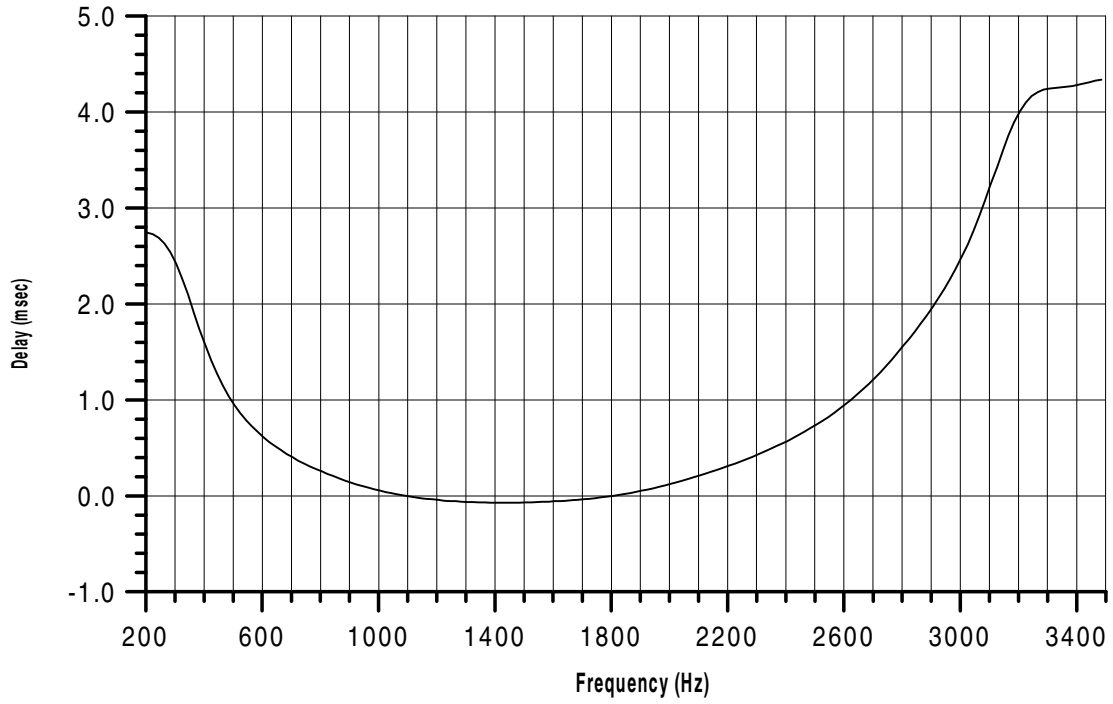

Figure 5-27. TAS "Enhanced" EIA 3 Delay Characteristic

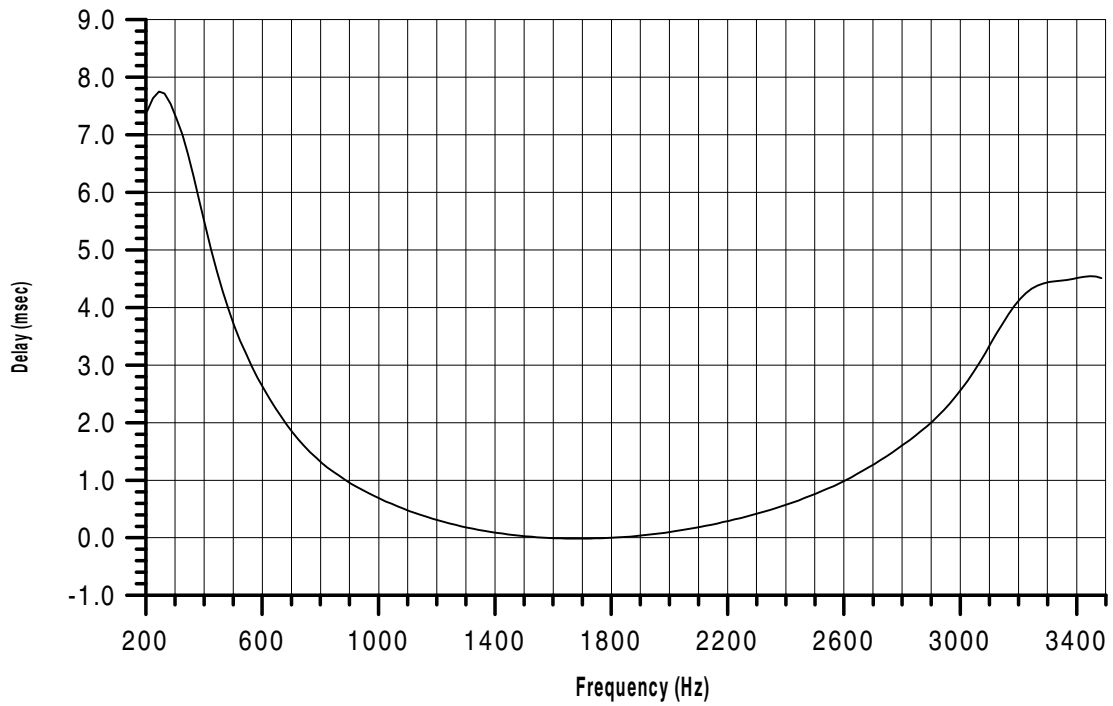

Figure 5-28. TAS "Enhanced" EIA 4 Delay Characteristic

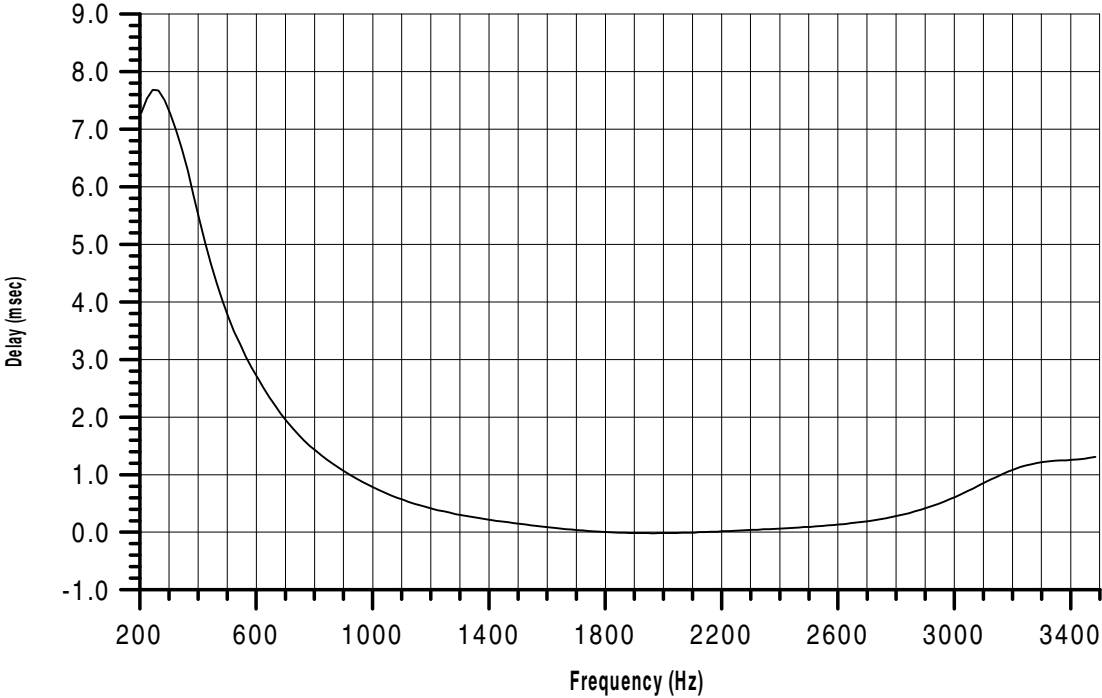

Figure 5-29. TAS Enhanced” EIA 5 Delay Characteristic

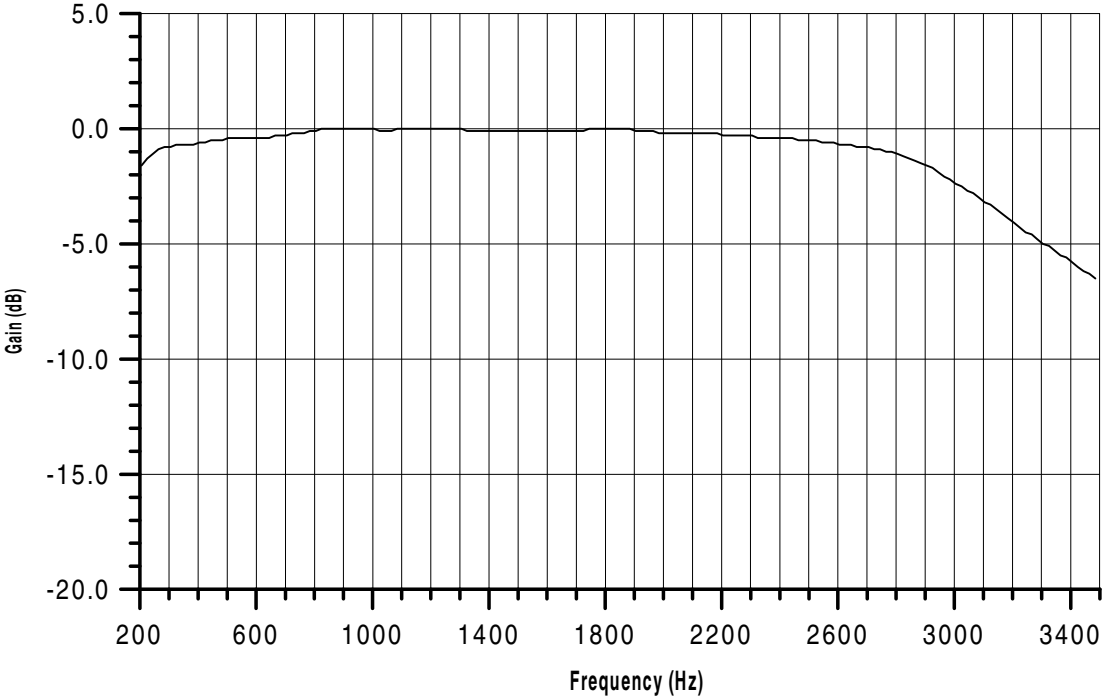
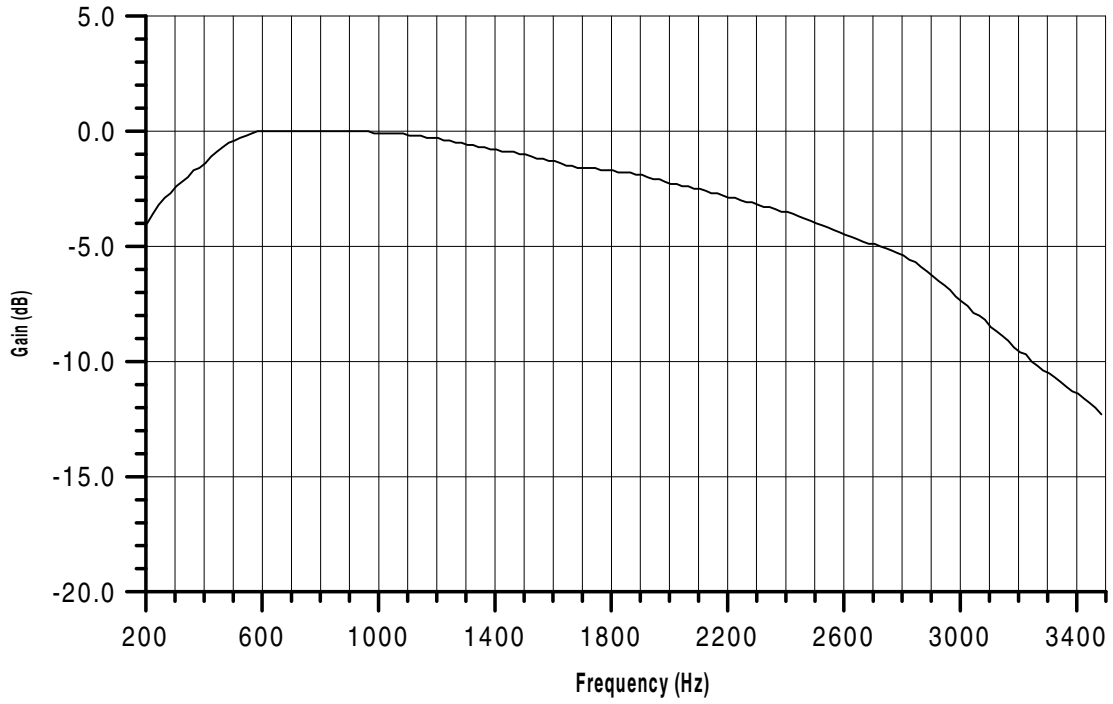
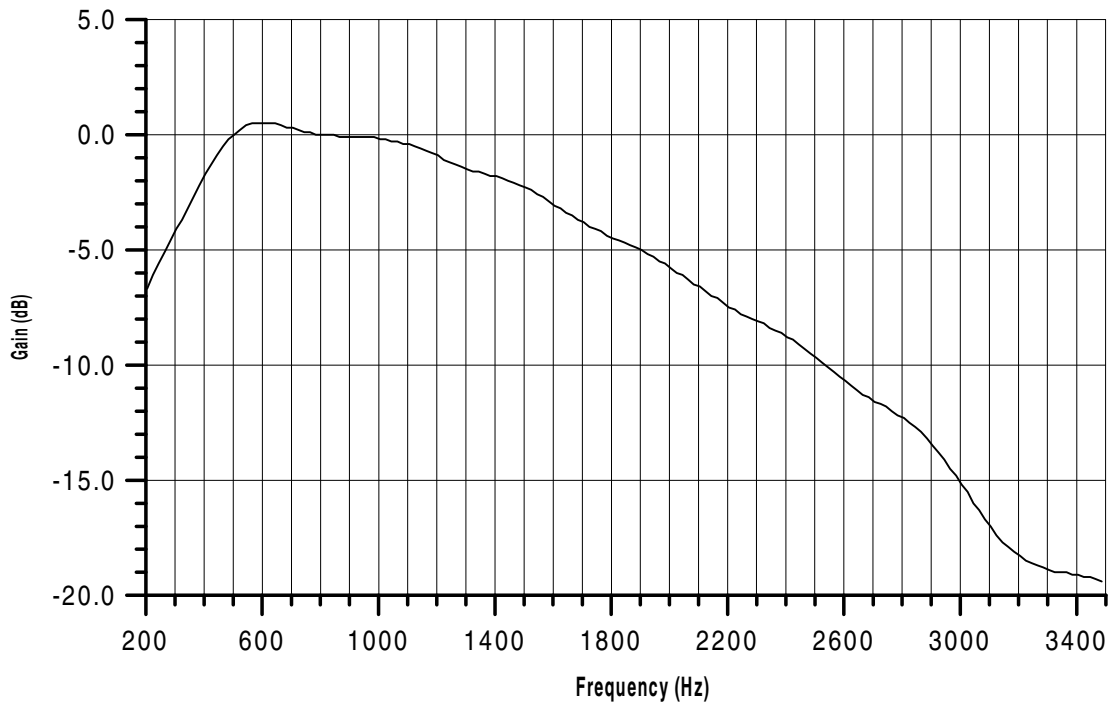

Figure 5-30. TAS “1010” Compatible” EIA A Gain Characteristics



**Figure 5-31. TAS "1010 Compatible" EIA B Gain Characteristics**



**Figure 5-32. TAS "1010 Compatible" EIA C Gain Characteristics**

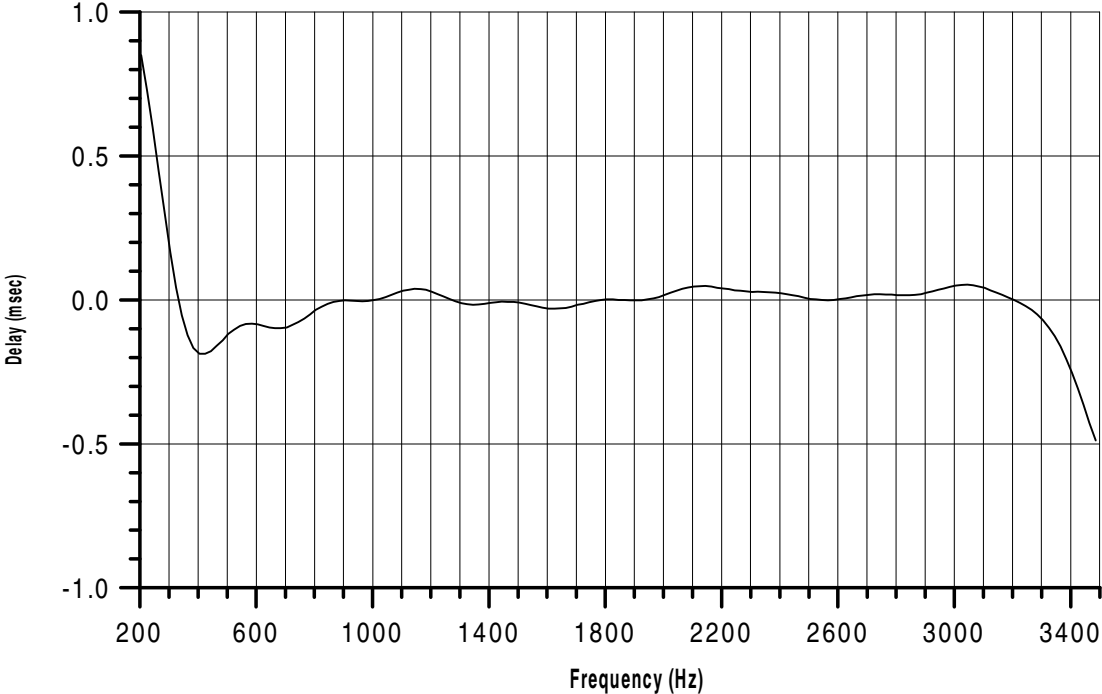

Figure 5-33. TAS “1010” Compatible” EIA 1 Delay Characteristic

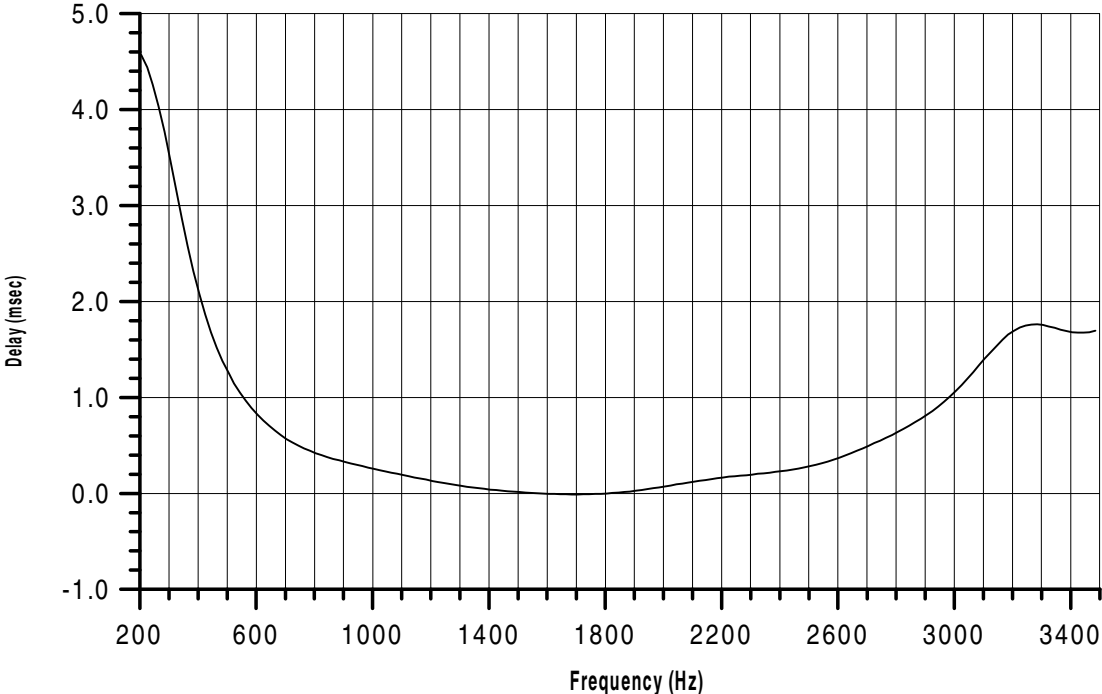

Figure 5-34. TAS “1010” Compatible” EIA 2 Delay Characteristic

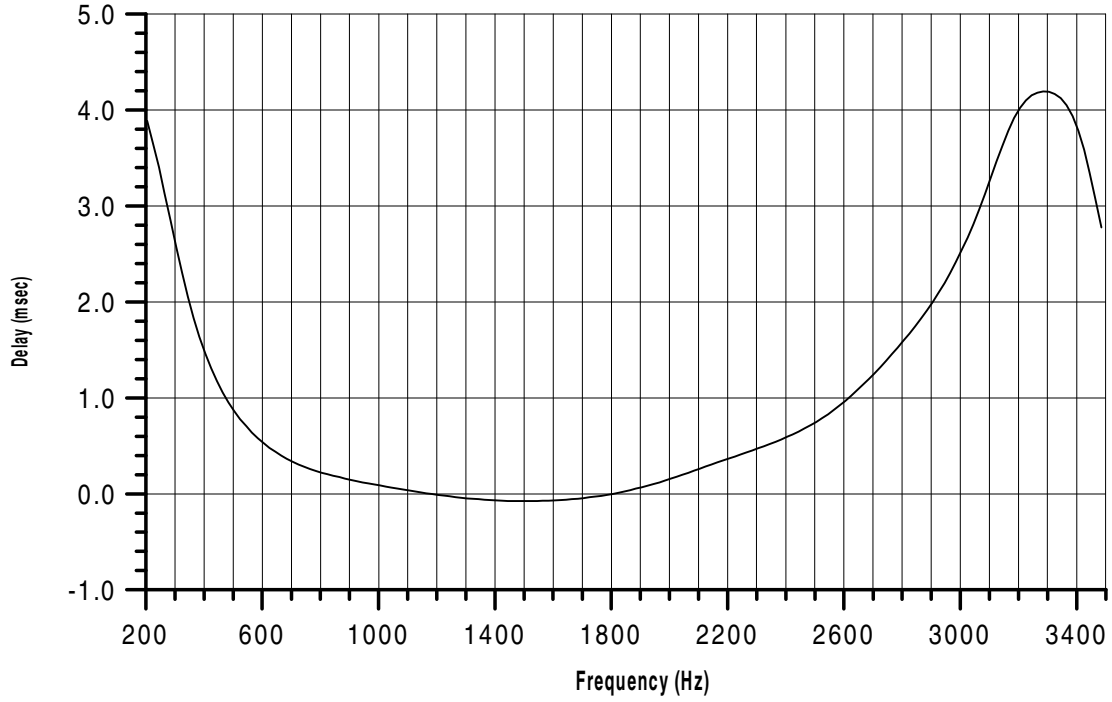

Figure 5-35. TAS "1010" Compatible" EIA 3 Delay Characteristic

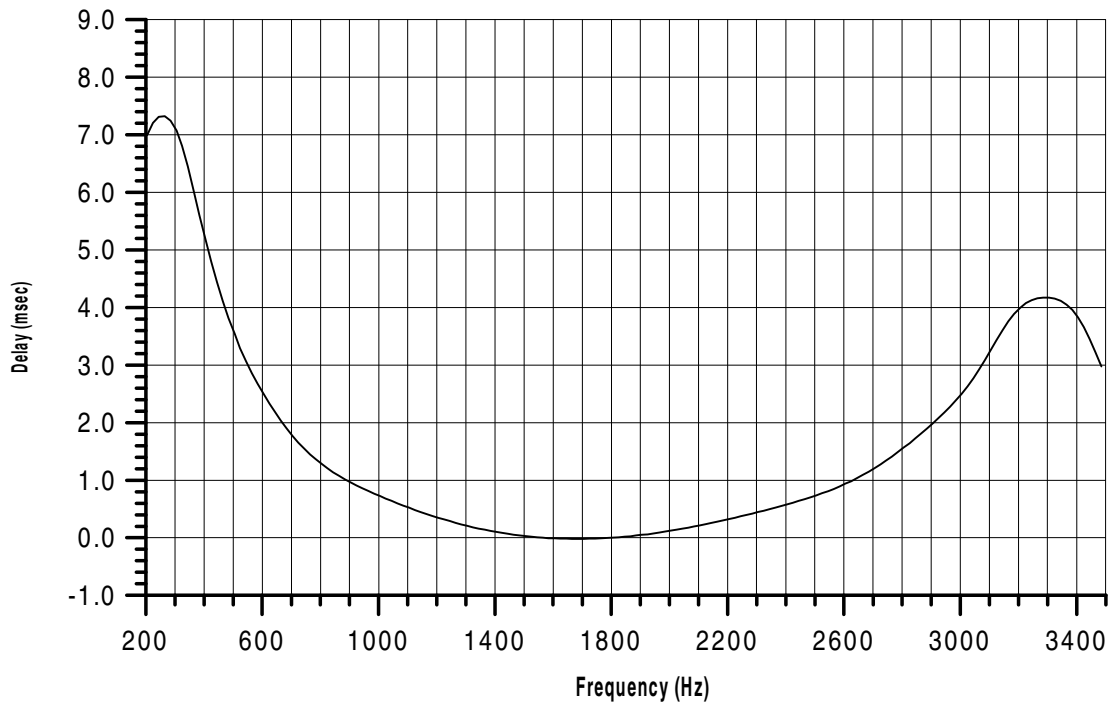

Figure 5-36. TAS "1010" Compatible" EIA 4 Delay Characteristic



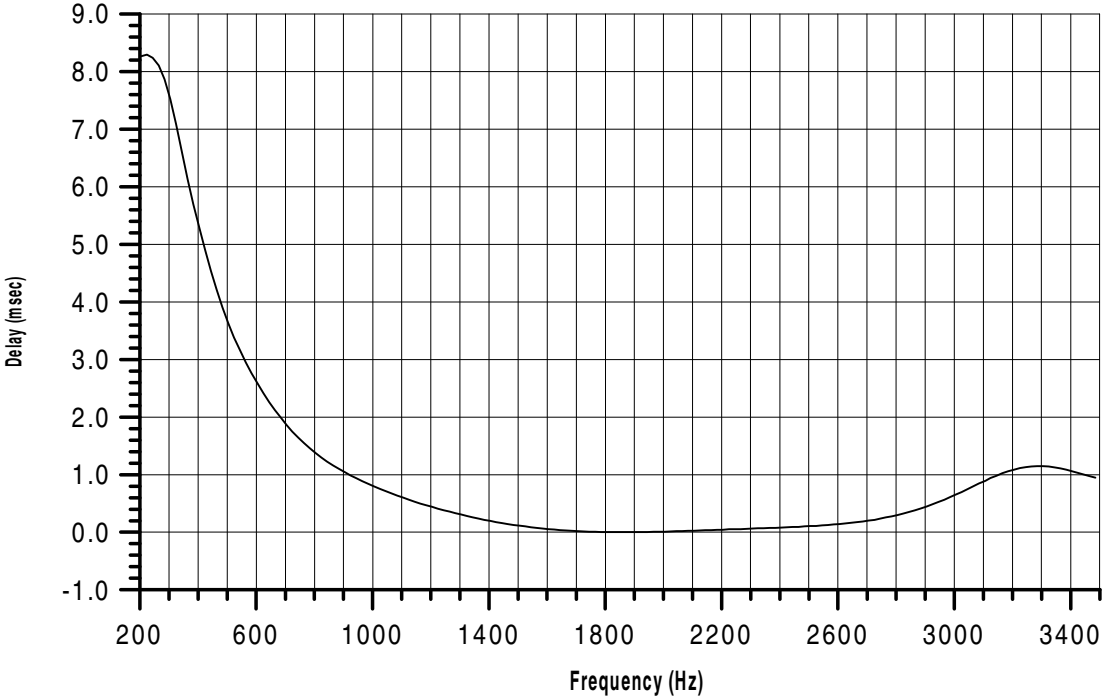

Figure 5-37. TAS "1010" Compatible" EIA 5 Delay Characteristic

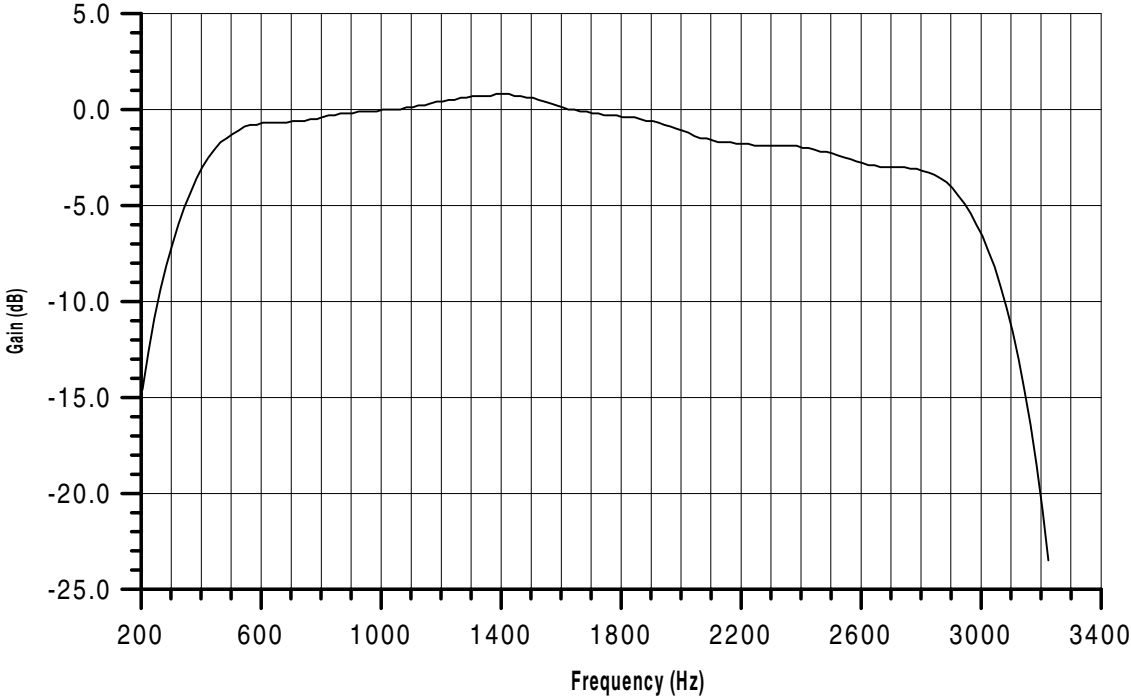

Figure 5-38. TAS CONUS Mid Data Gain

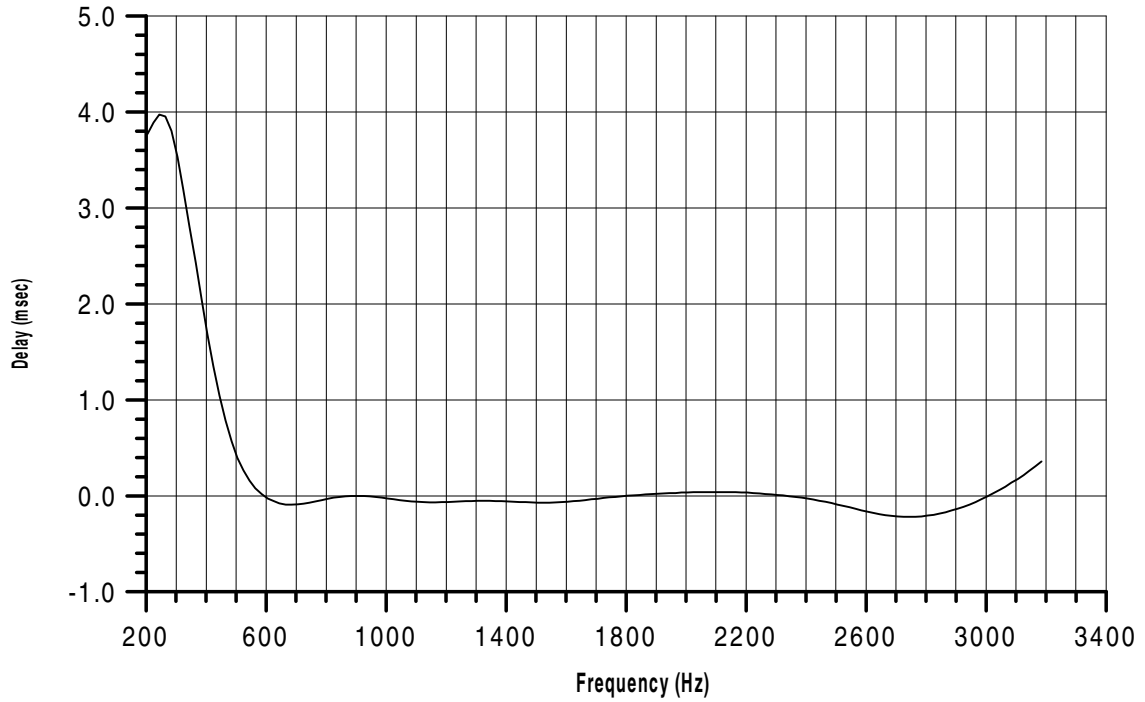

Figure 5-39. TAS CONUS Mid Data Delay

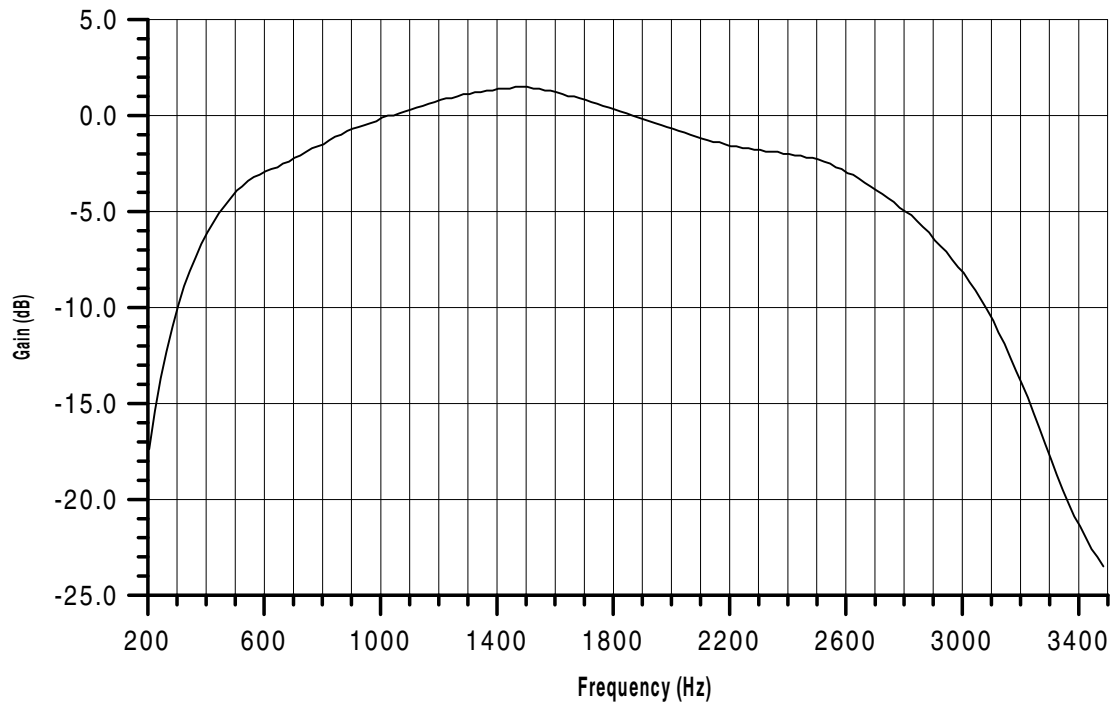

Figure 5-40. TAS CONUS Mid Voice Gain

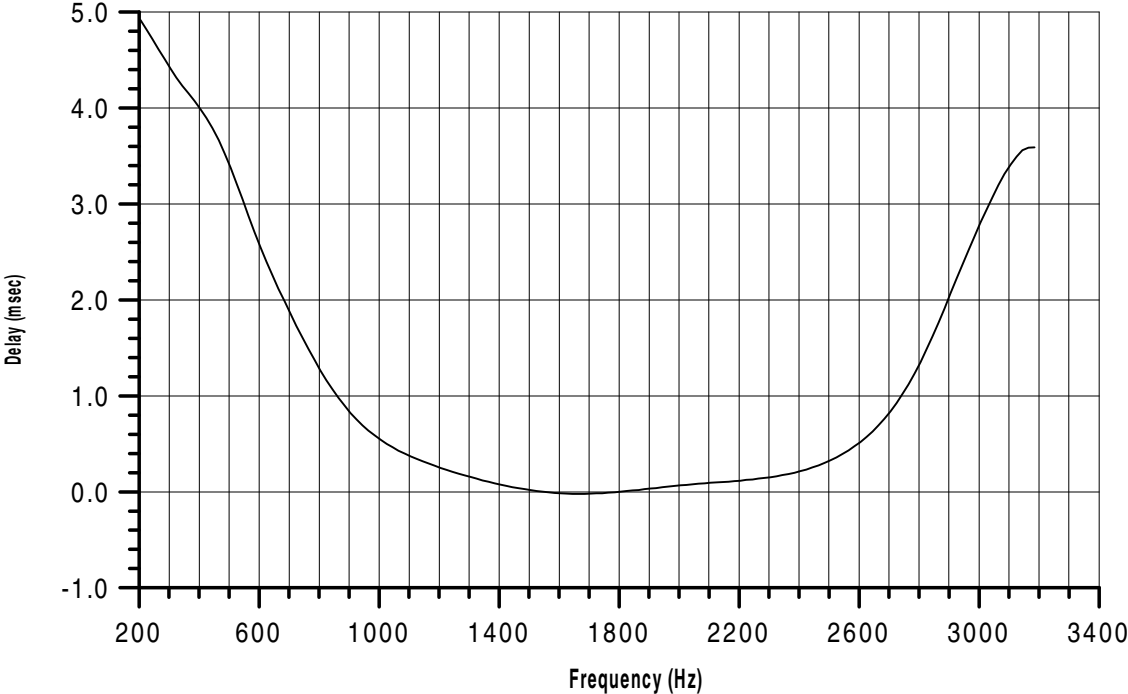

Figure 5-41. TAS CONUS Mid Voice Delay

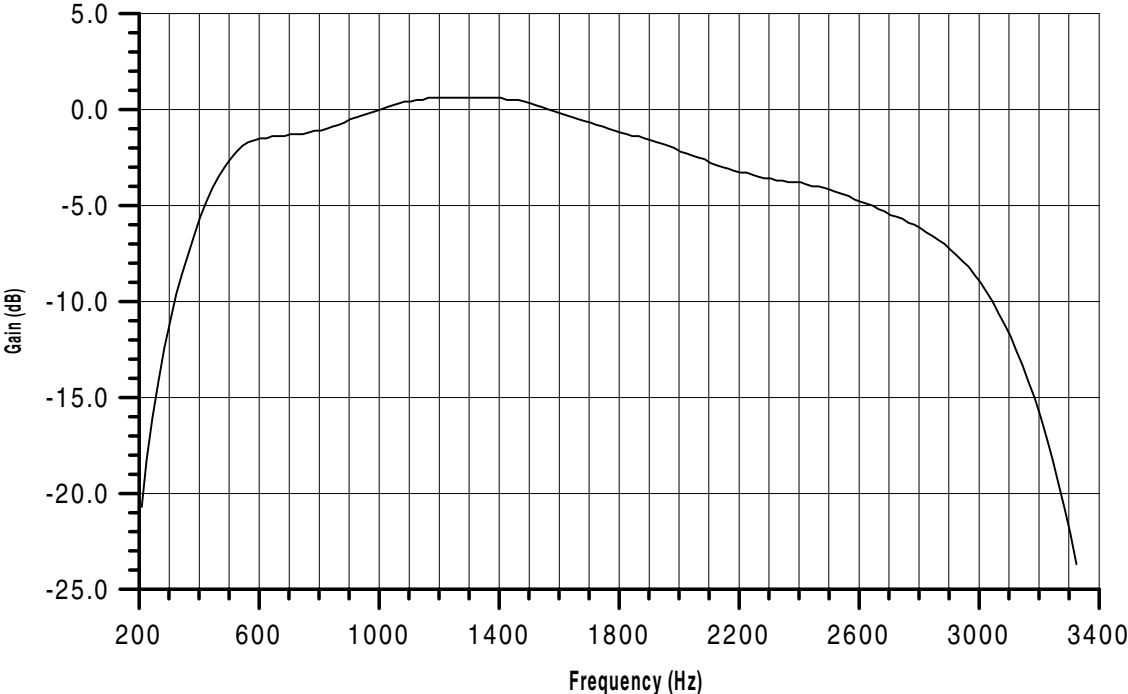

Figure 5-42. TAS CONUS Poor Data Gain

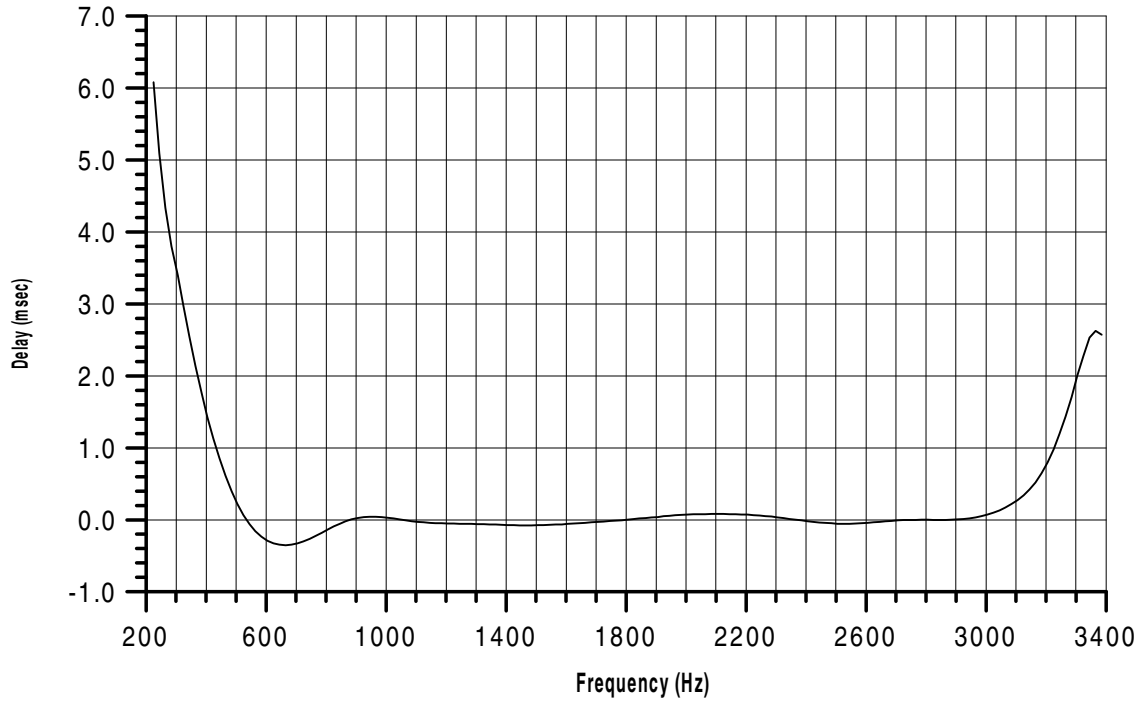

Figure 5-43. TAS CONUS Poor Data Delay

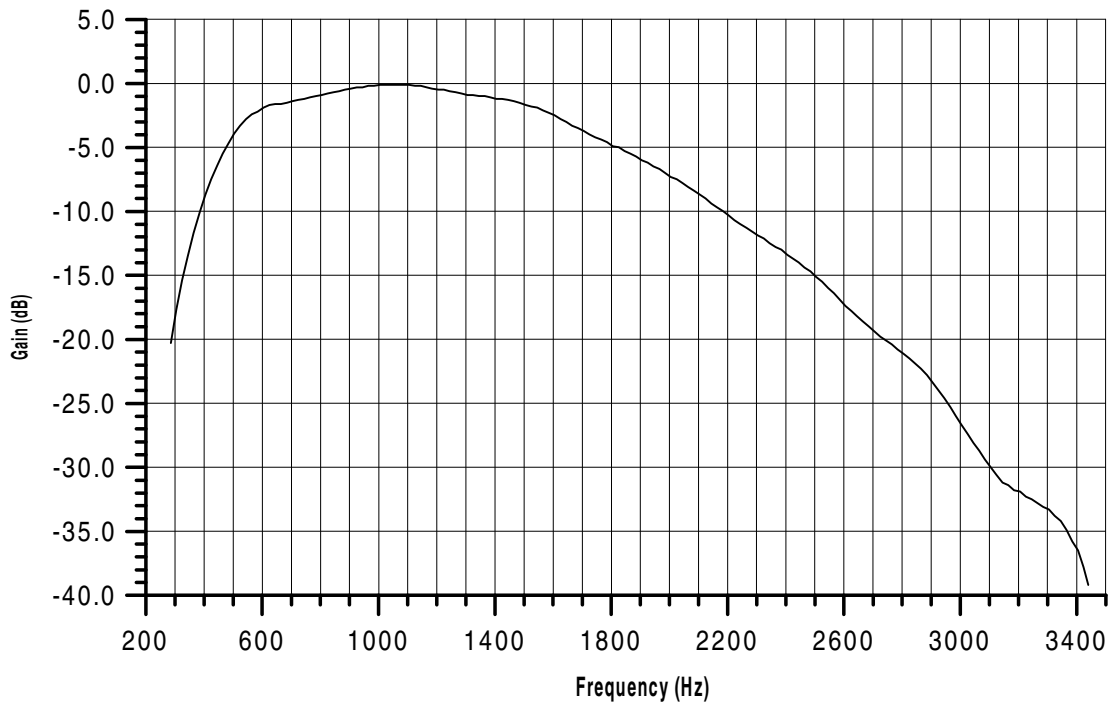

Figure 5-44. TAS CONUS Poor Voice Gain

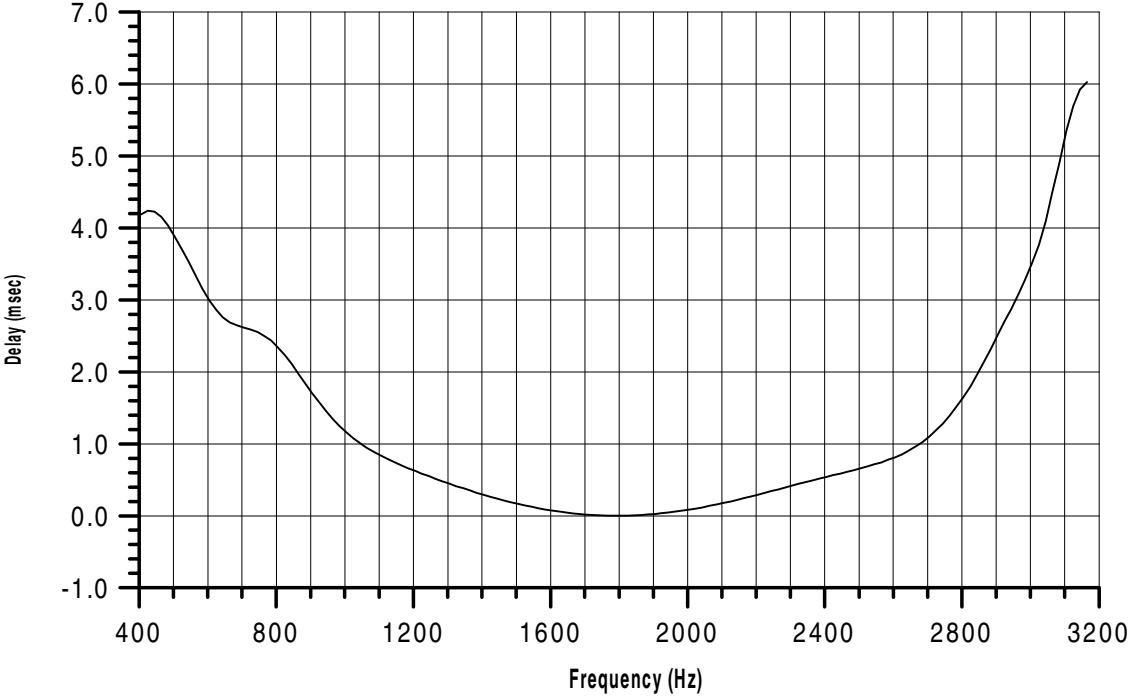

Figure 5-45. TAS CONUS Poor Voice Delay

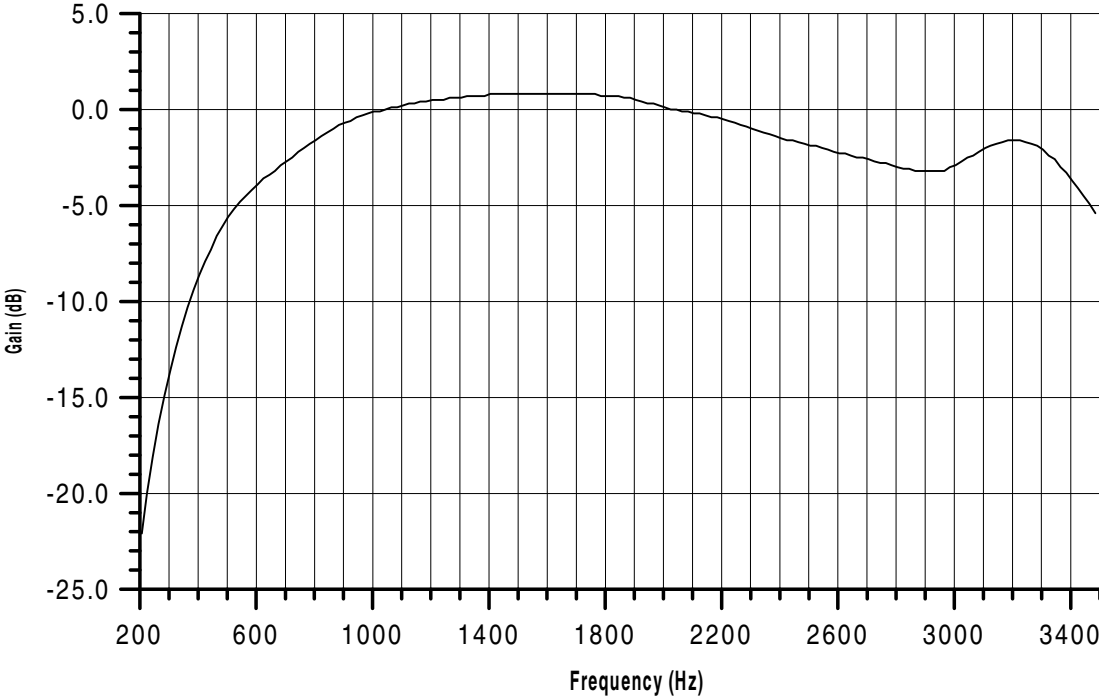

Figure 5-46. TAS European Mid Data Gain

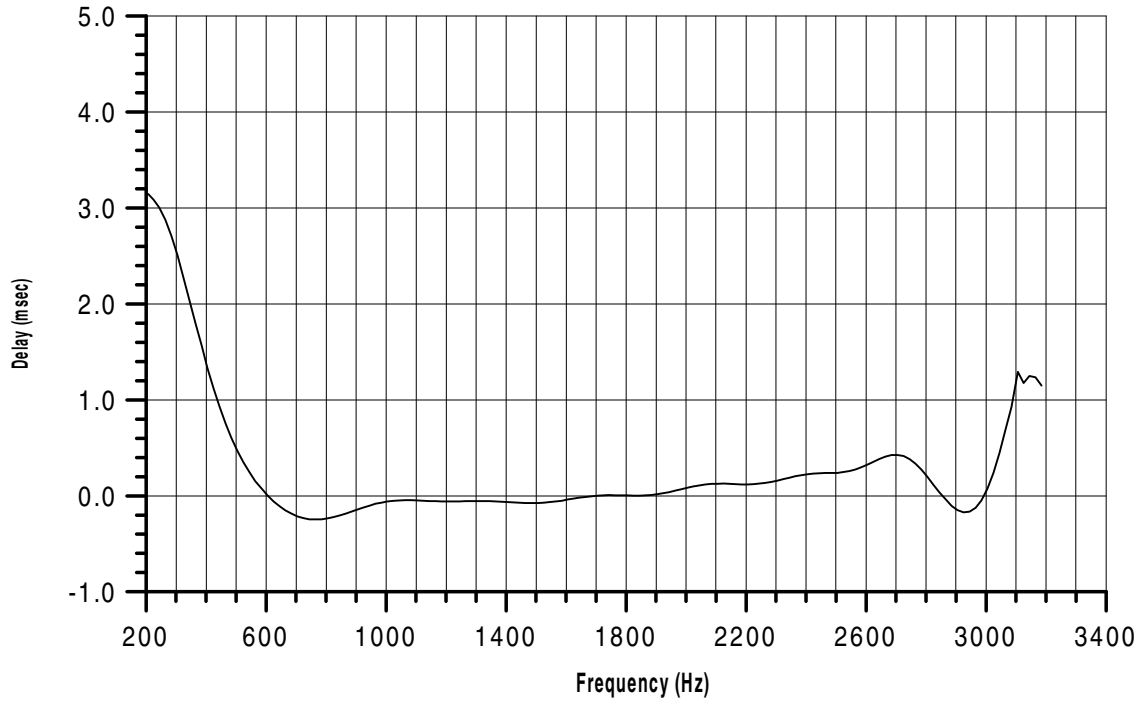

Figure 5-47. TAS European Mid Data Delay

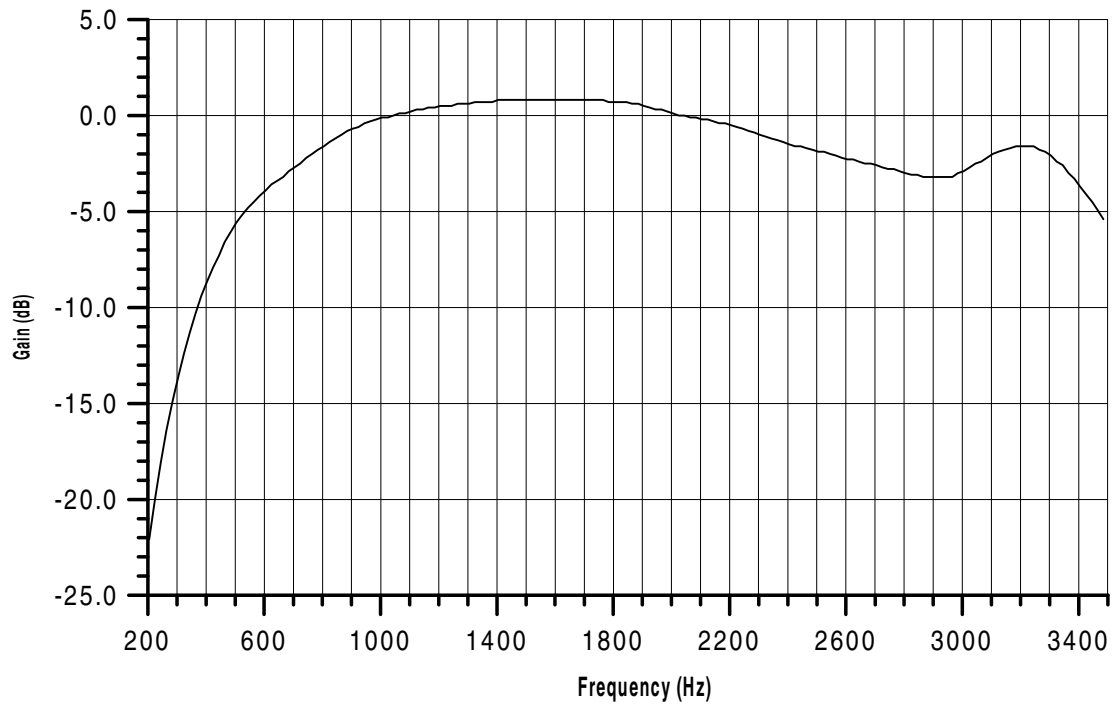

Figure 5-48. TAS European Poor Data Gain

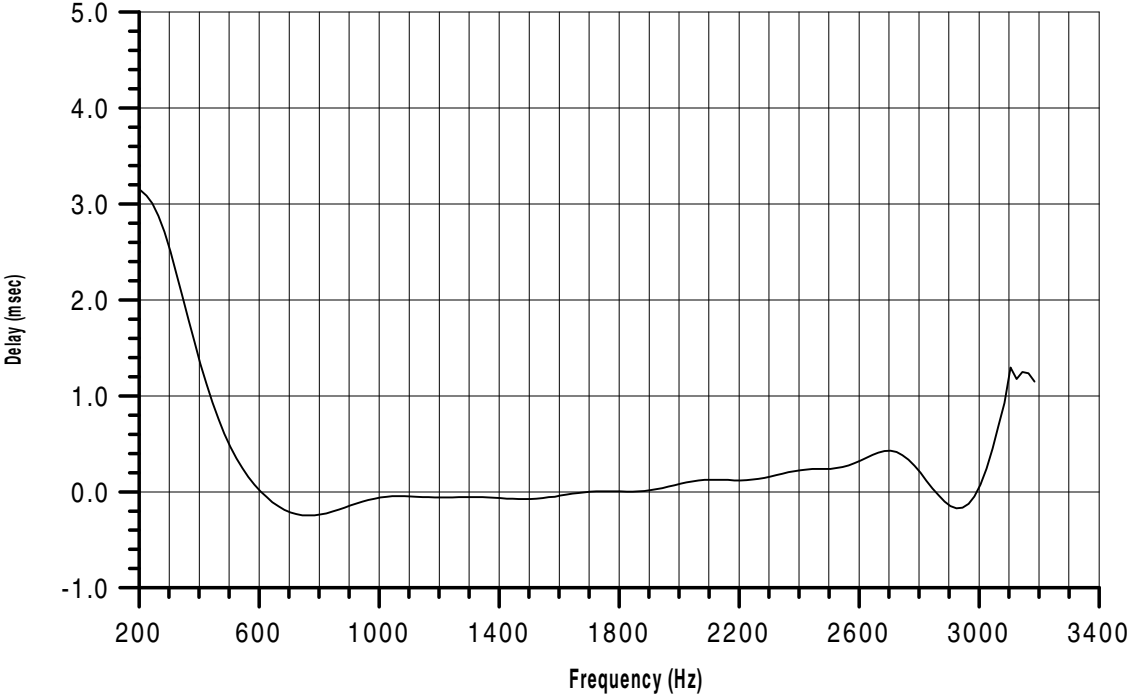

Figure 5-49. TAS European Poor Data Delay

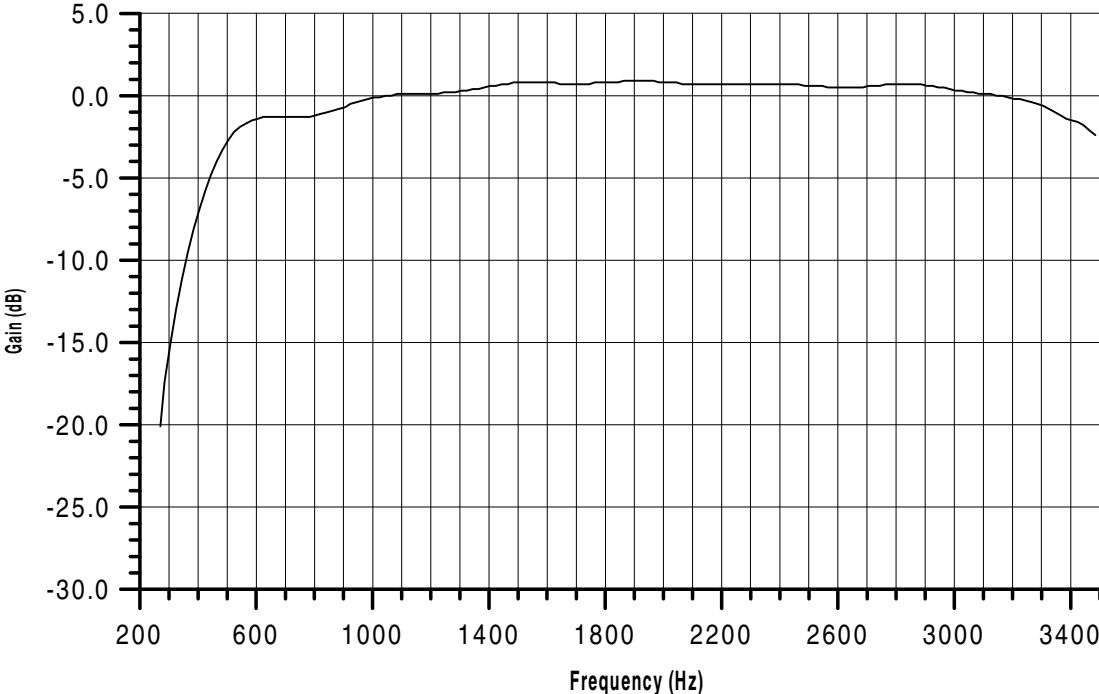

Figure 5-50. TAS European Mid Voice Gain

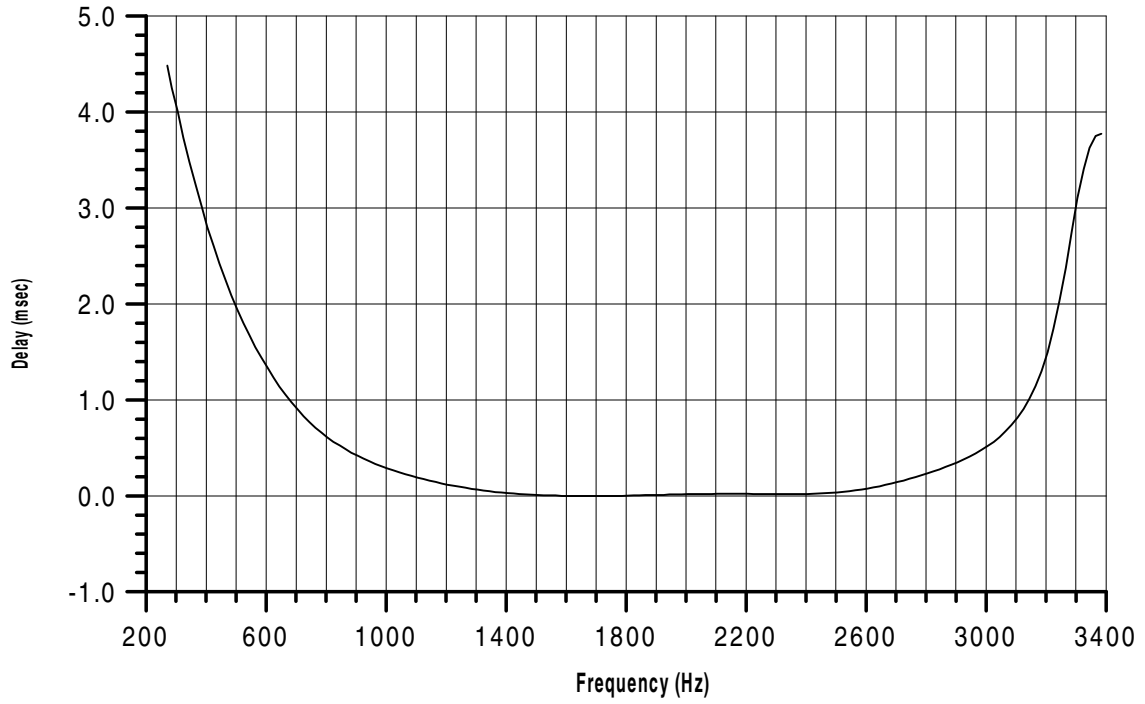

Figure 5-51. TAS European Mid Voice Delay

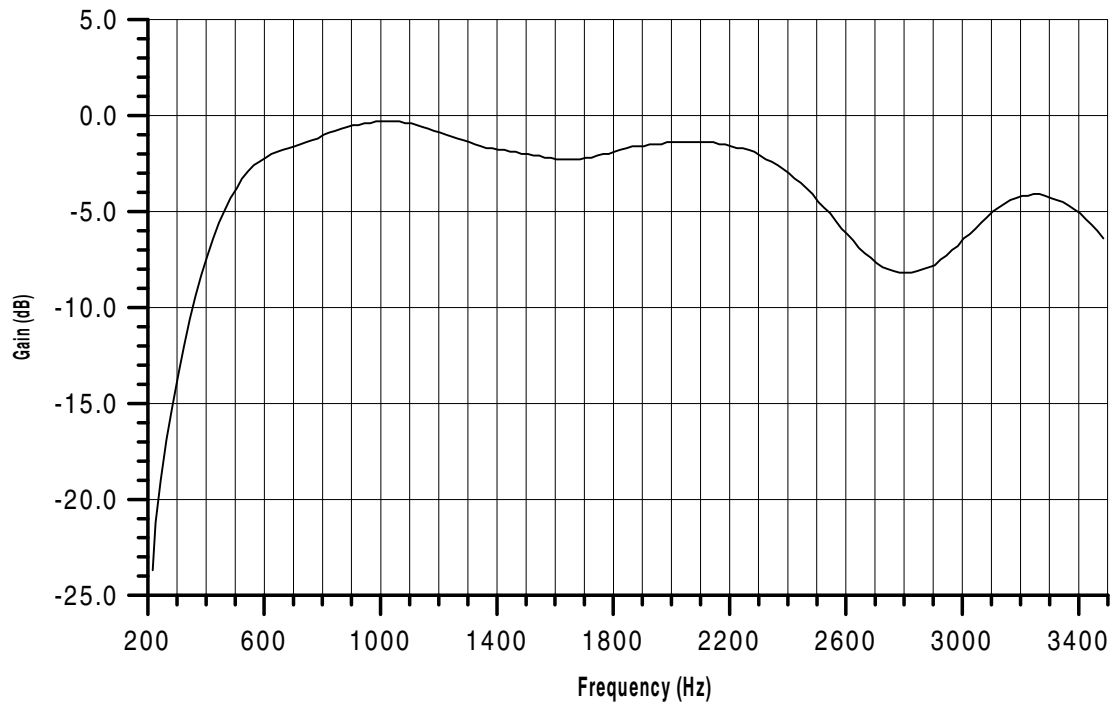

Figure 5-52. TAS European Poor Voice Gain



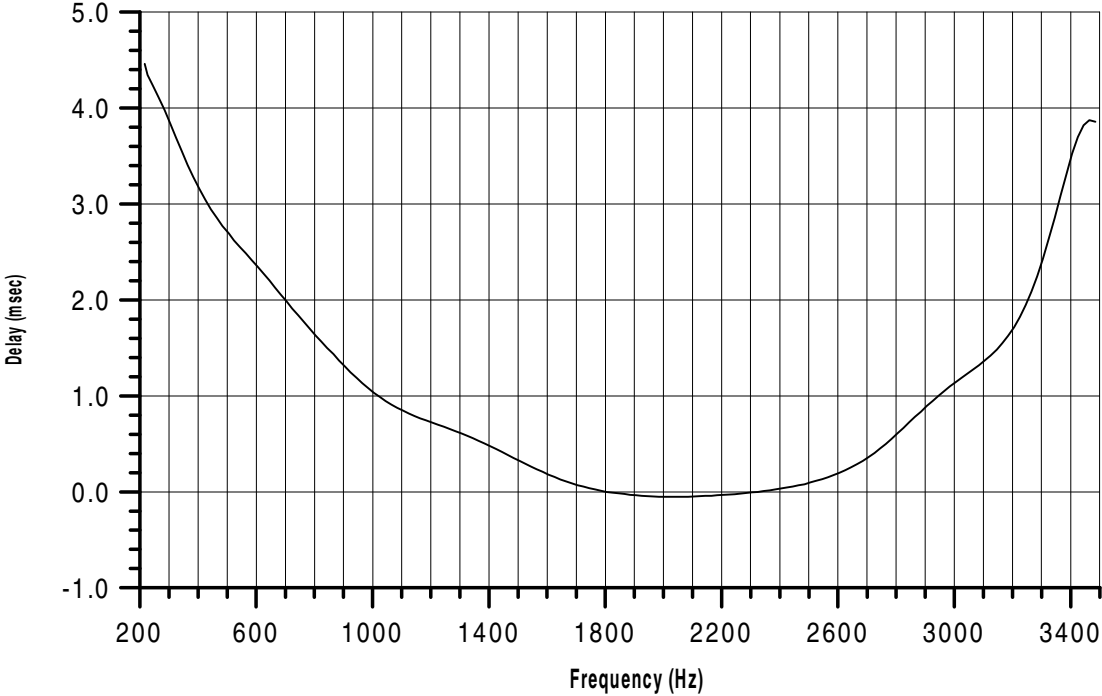

Figure 5-53. TAS European Poor Voice Delay

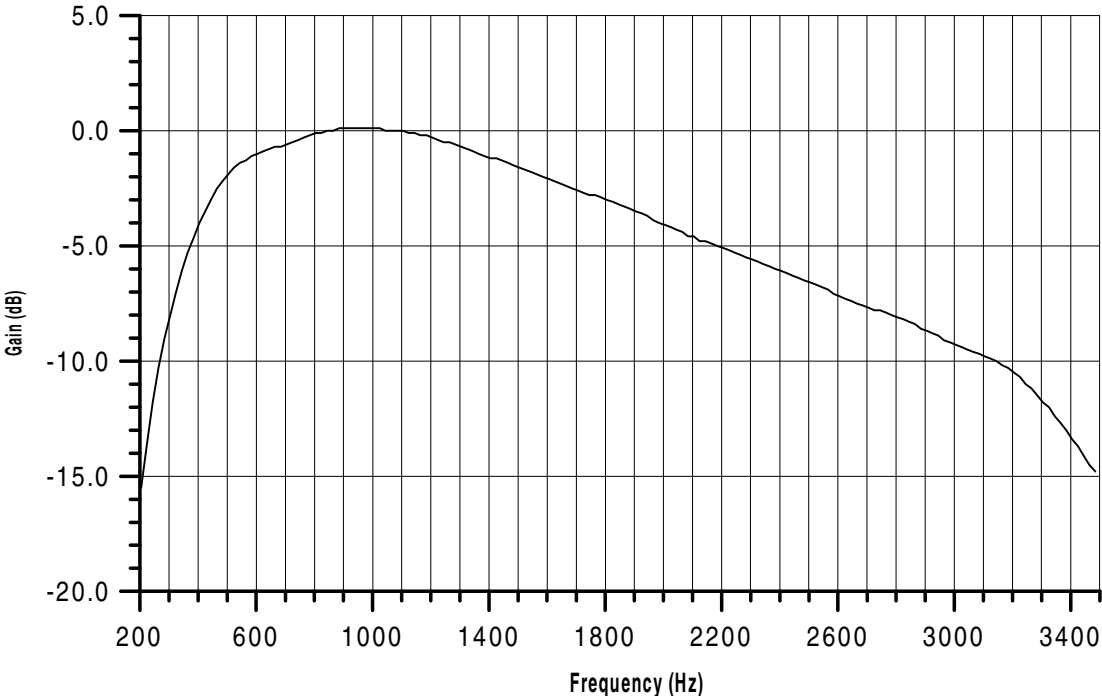

Figure 5-54. TAS NSB Gain

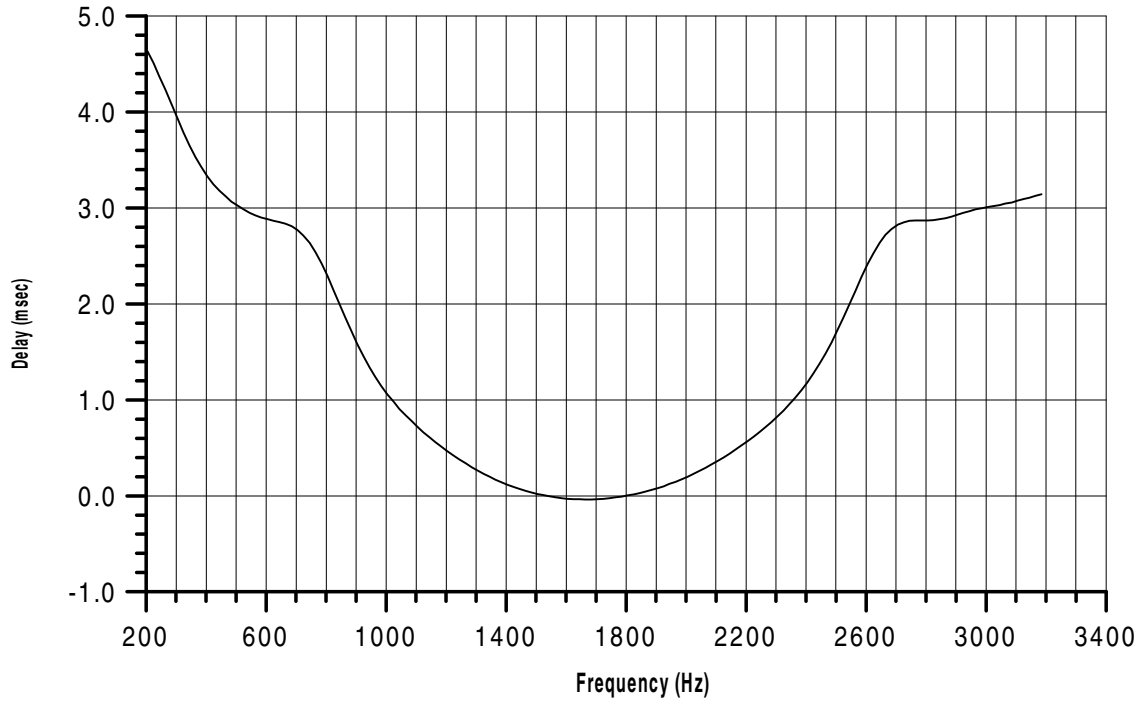

Figure 5-55. TAS NSB Delay

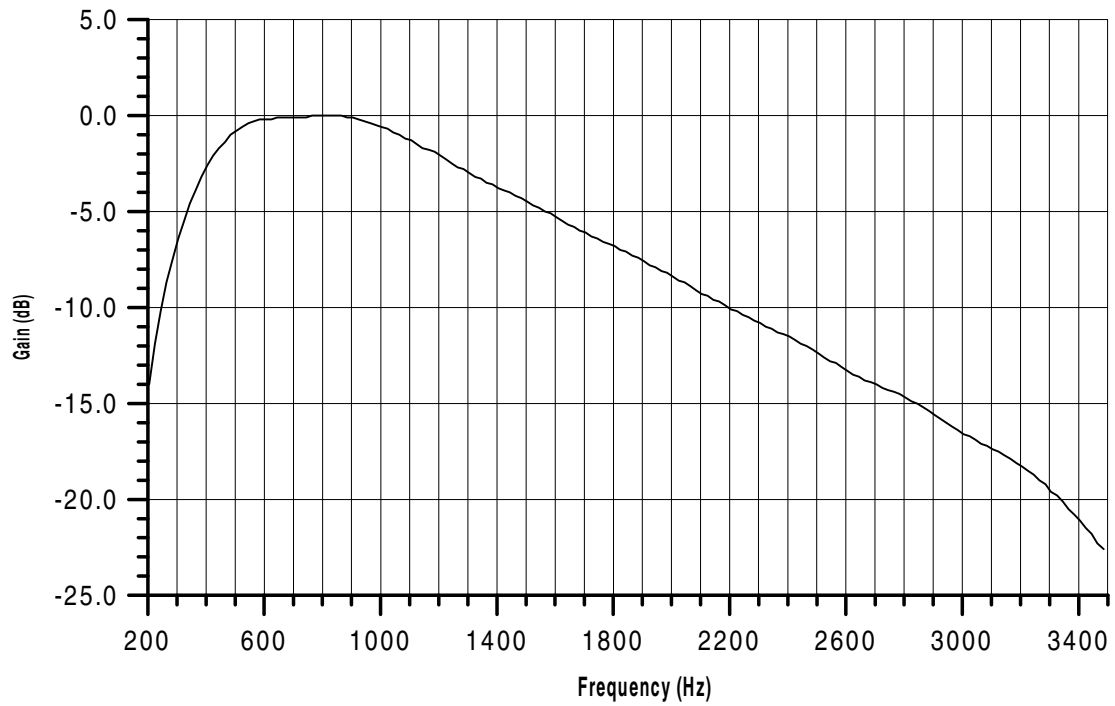

Figure 5-56. TAS NTB Gain

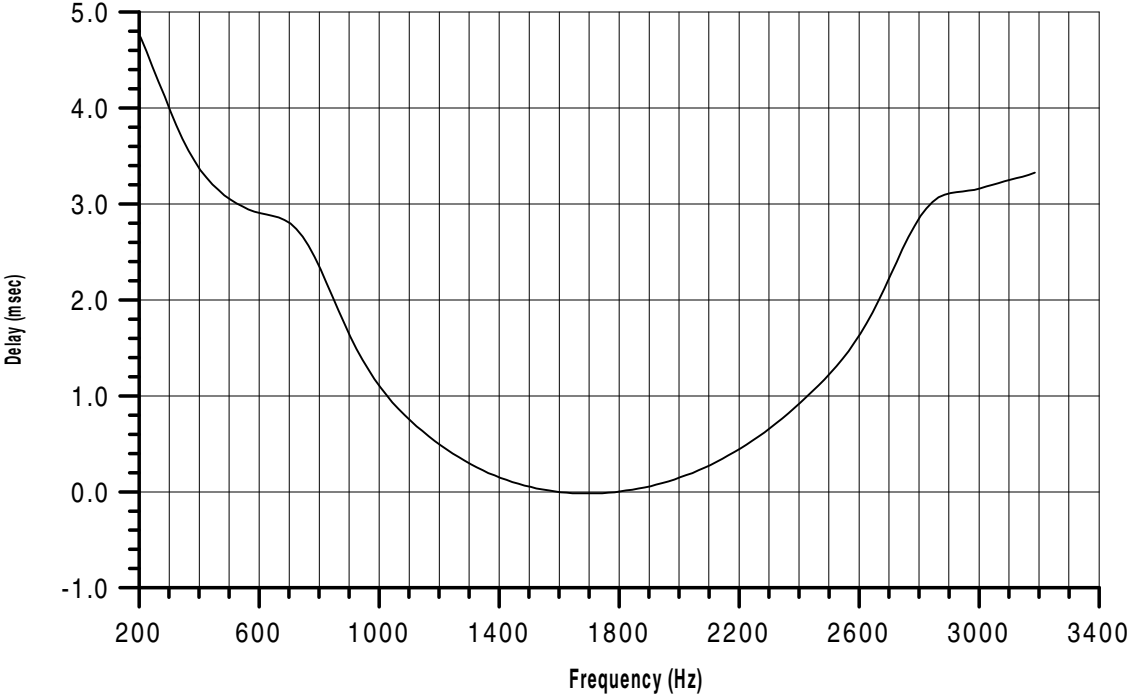

Figure 5-57. TAS NTB Delay

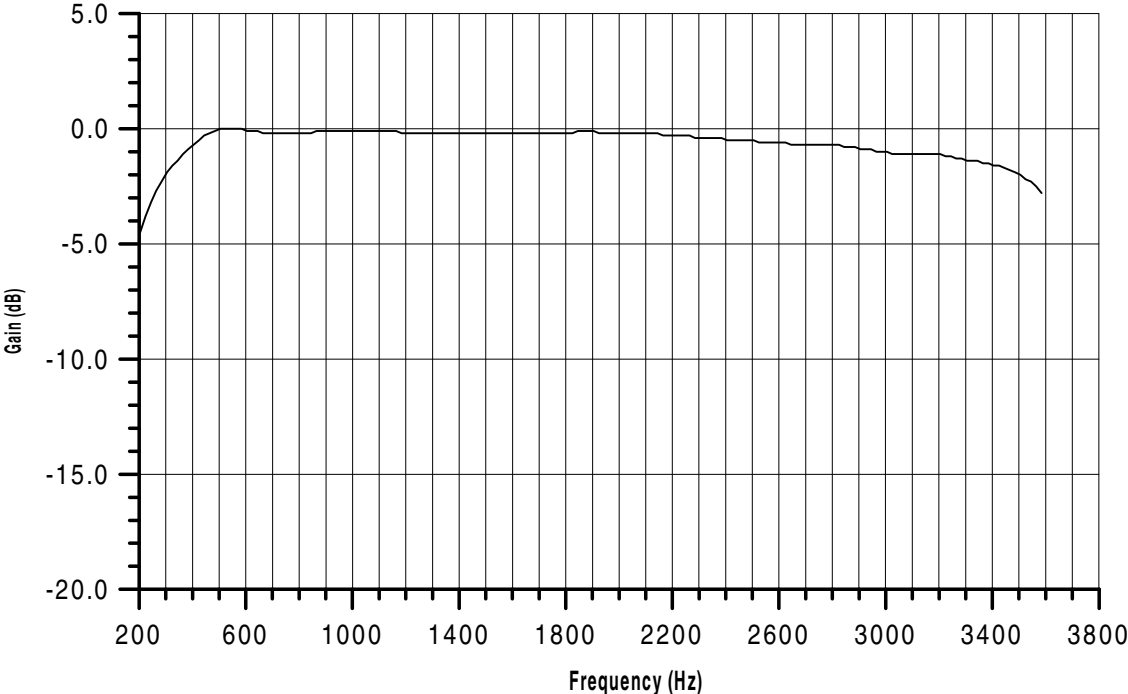

Figure 5-58. TAS JPN 1 Gain

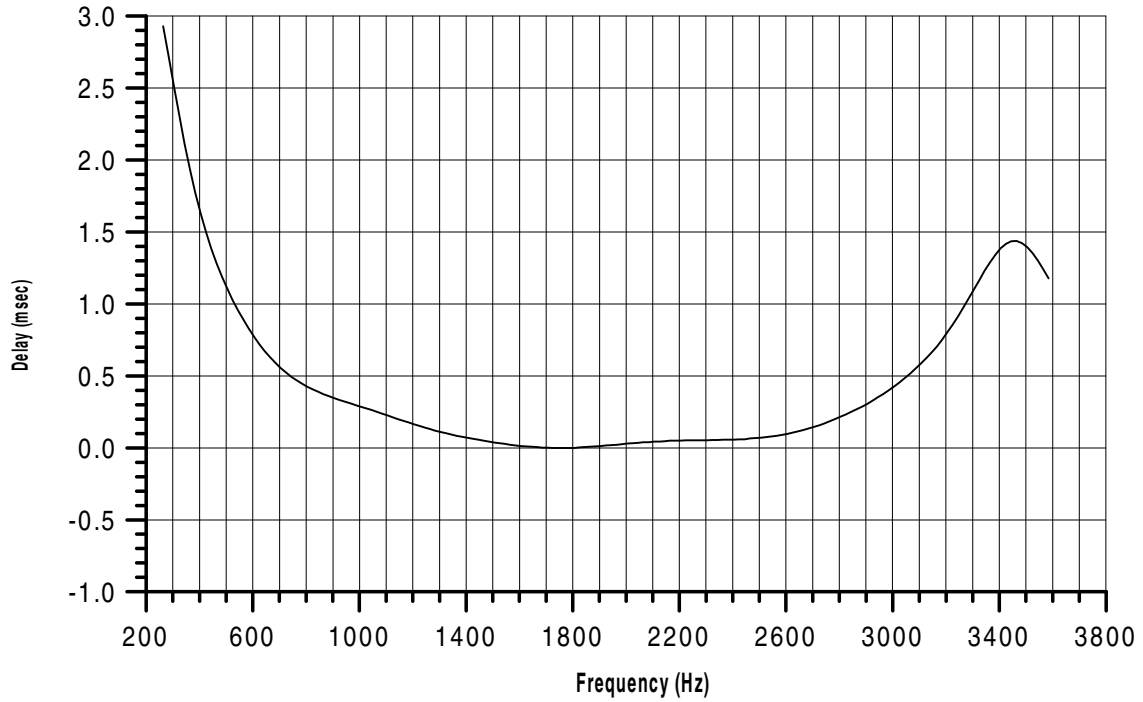

Figure 5-59. TAS JPN 1 Delay

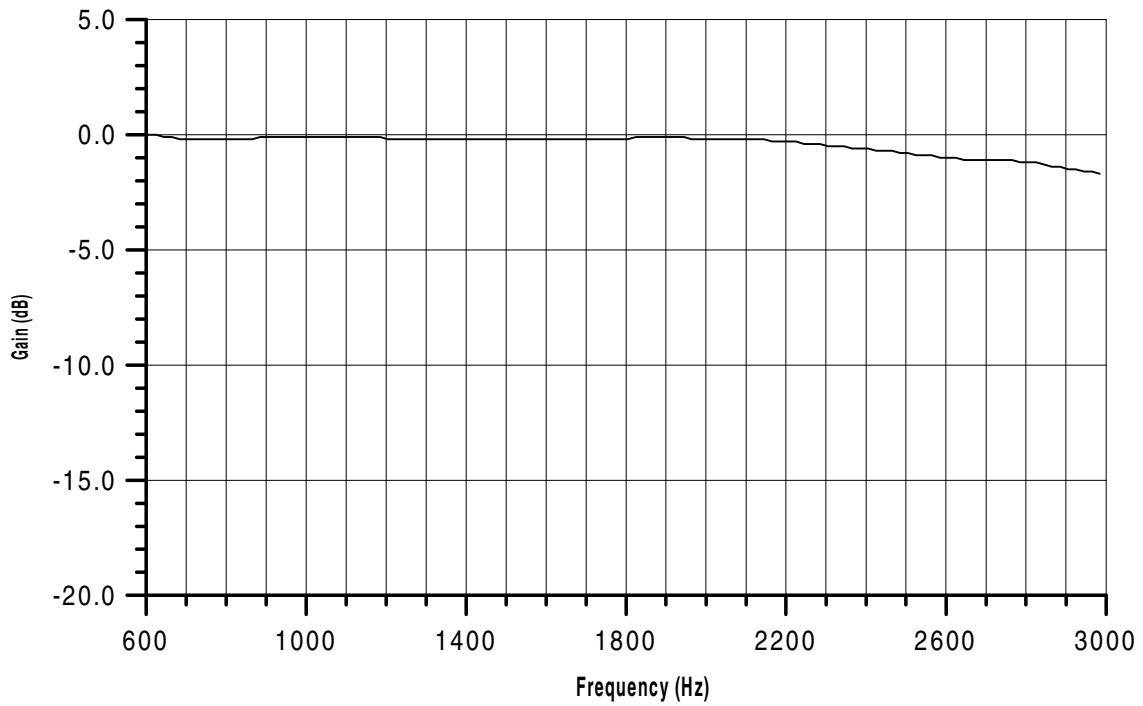

Figure 5-60. TAS JPN 2 Gain

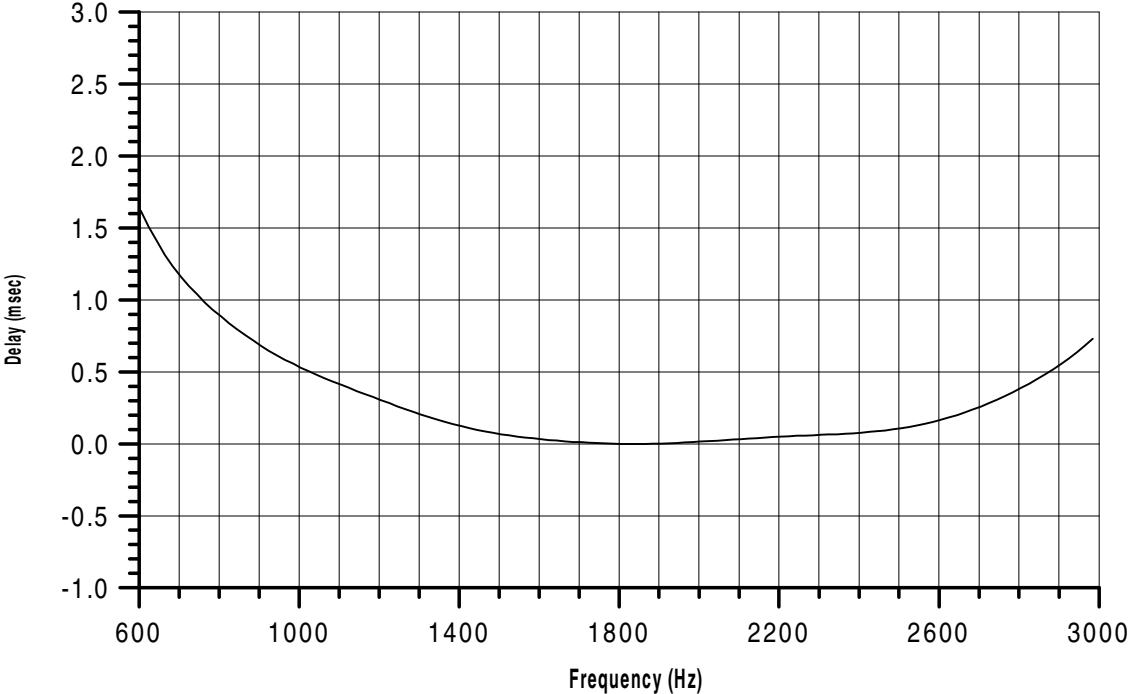

Figure 5-61. TAS JPN 2 Delay

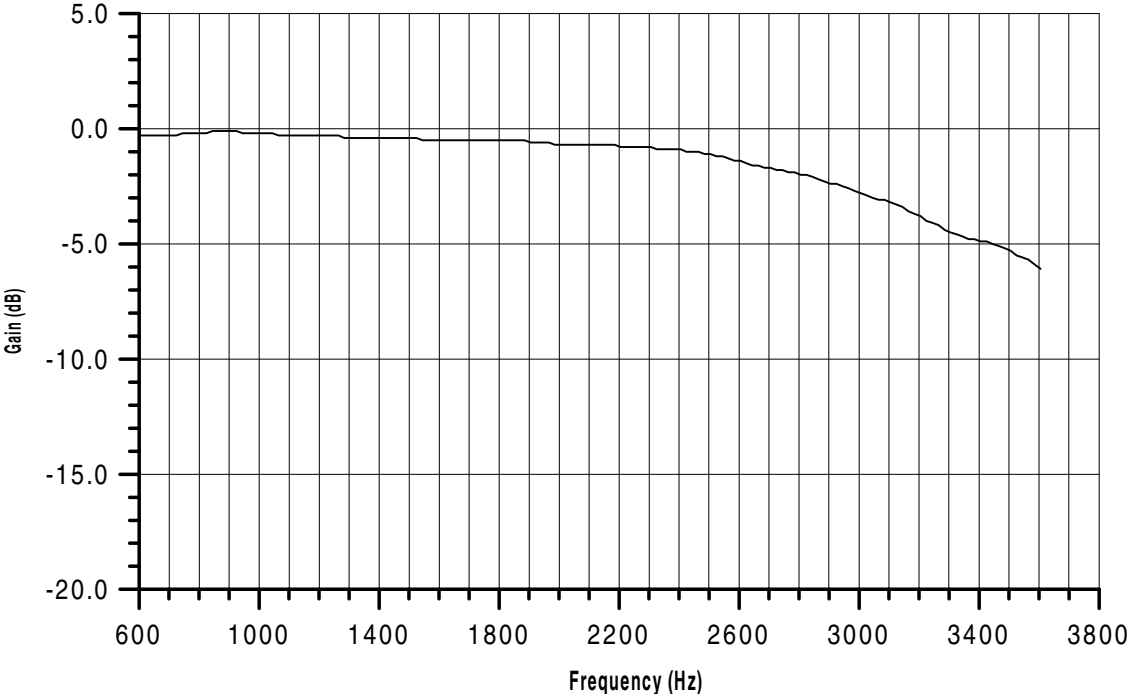

Figure 5-62. TAS JPN 3 Gain

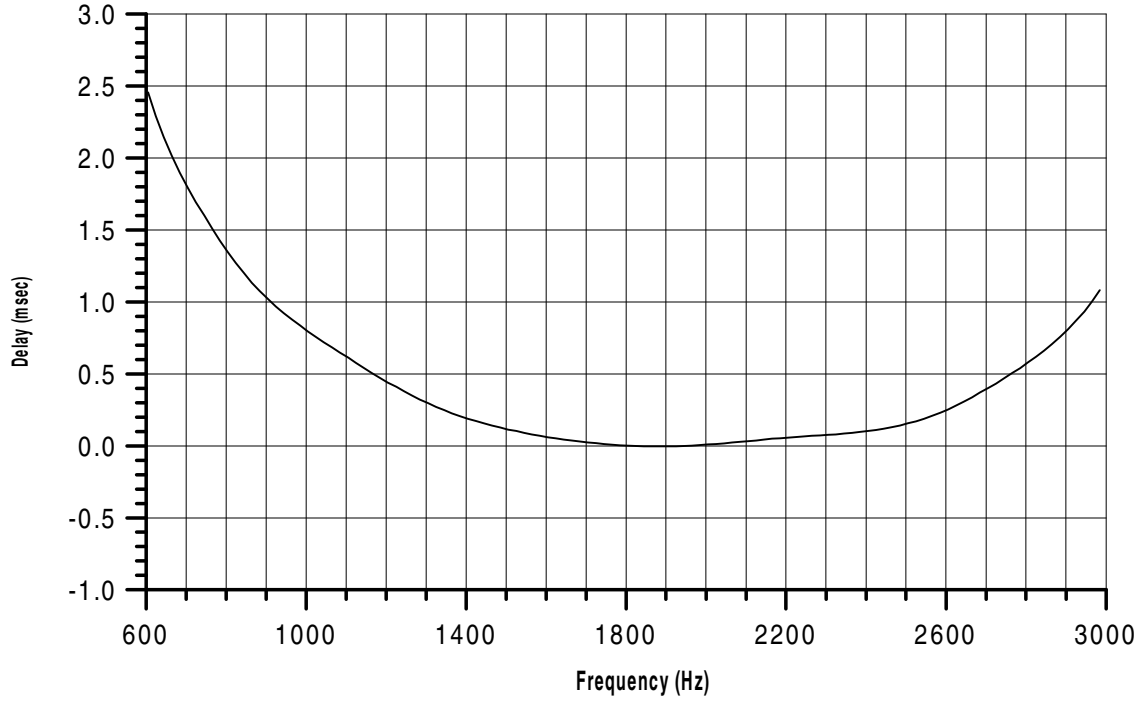

Figure 5-63. TAS JPN 3 Delay

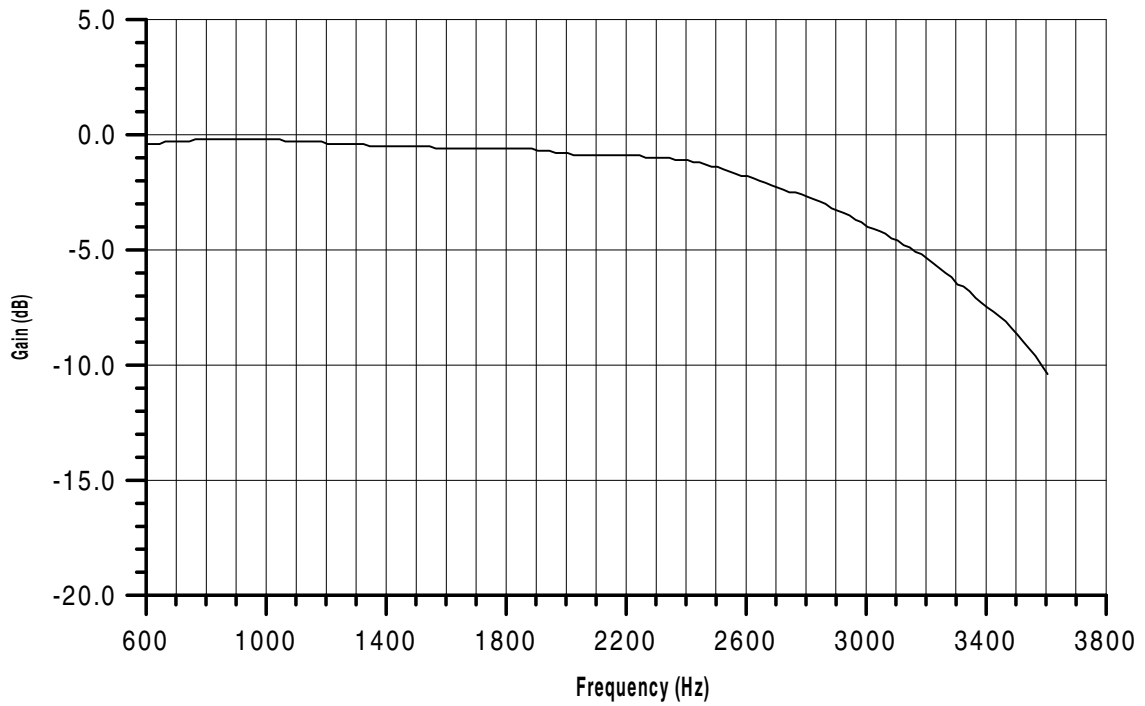

Figure 5-64. TAS JPN 4 Gain

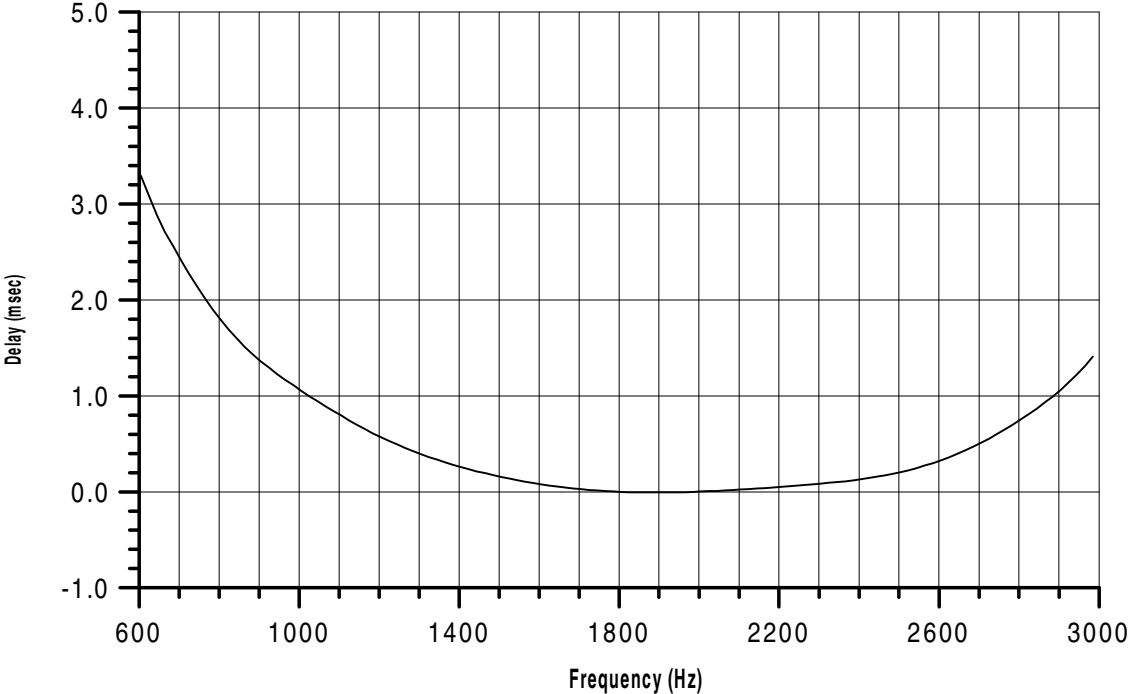

Figure 5-65 TAS JPN 4 Delay

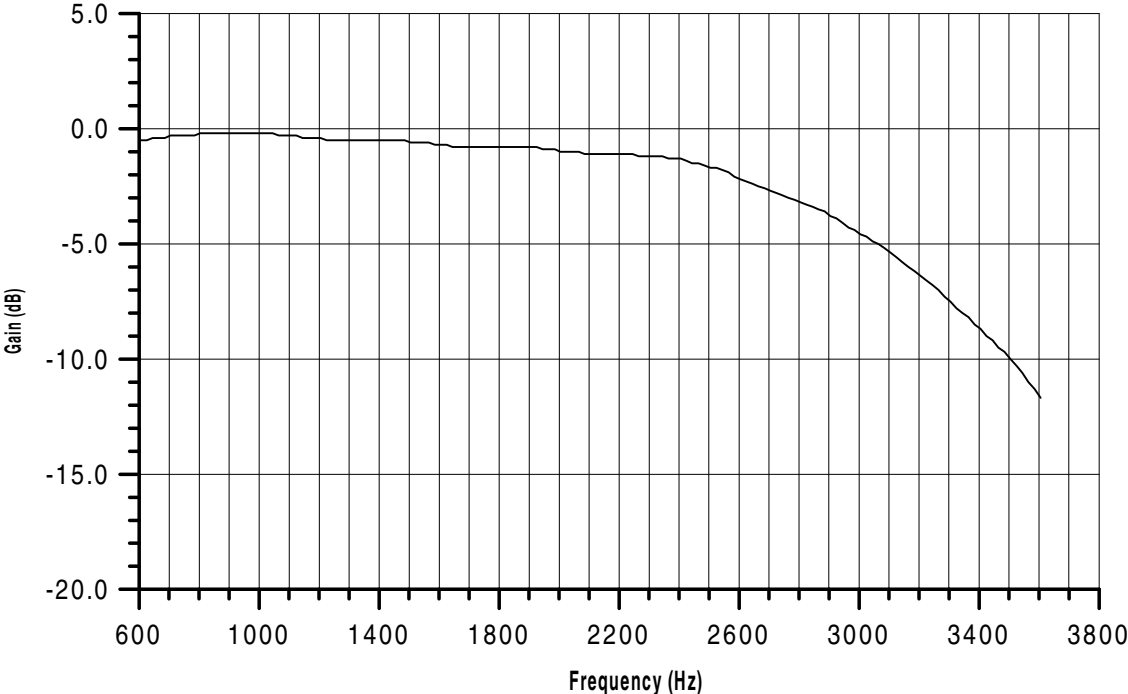

Figure 5-66 TAS JPN 5 Gain

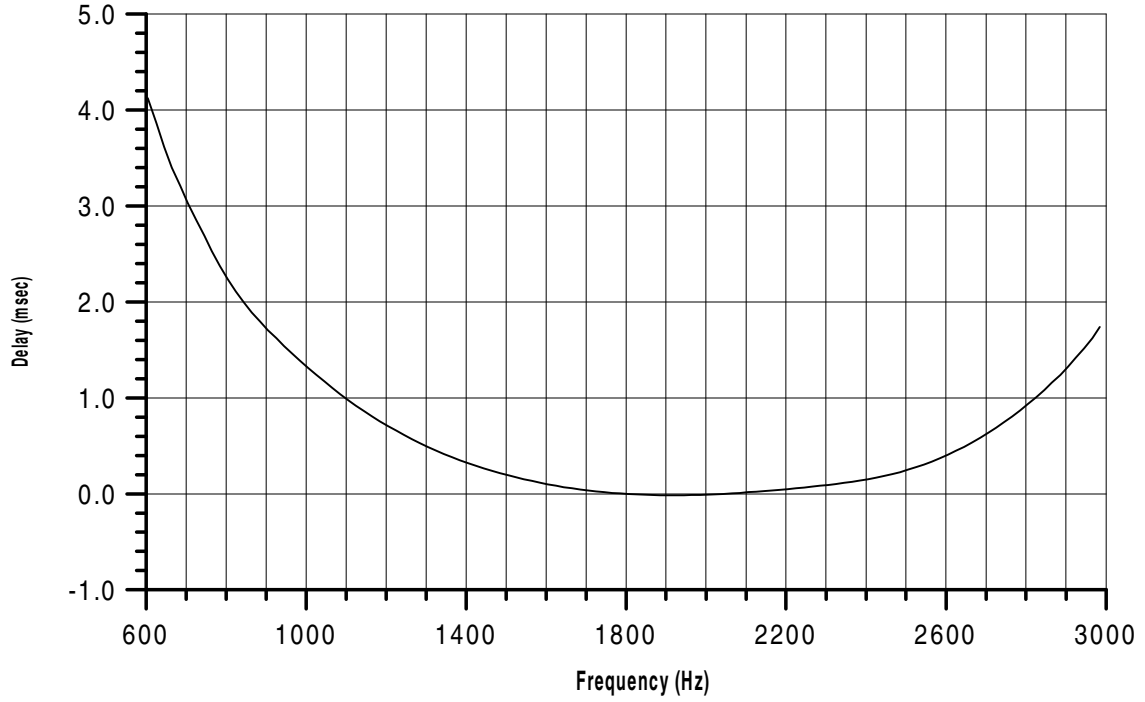

Figure 5-67. TAS JPN 5 Delay

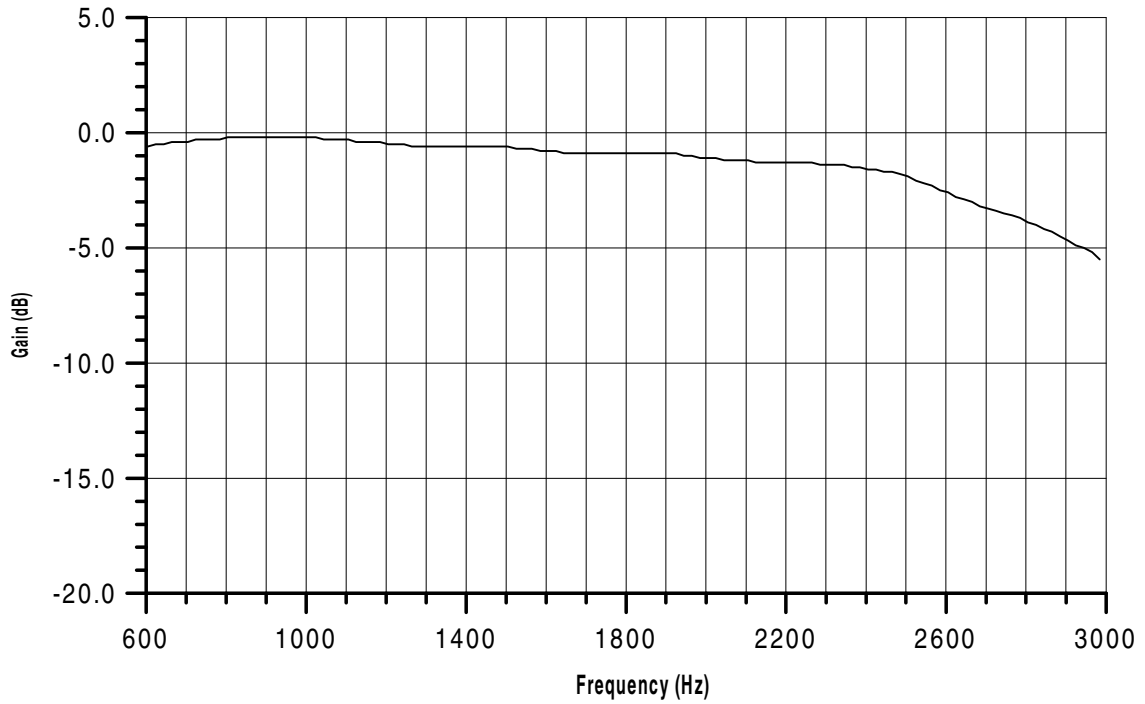

Figure 5-68 TAS JPN 6 Gain



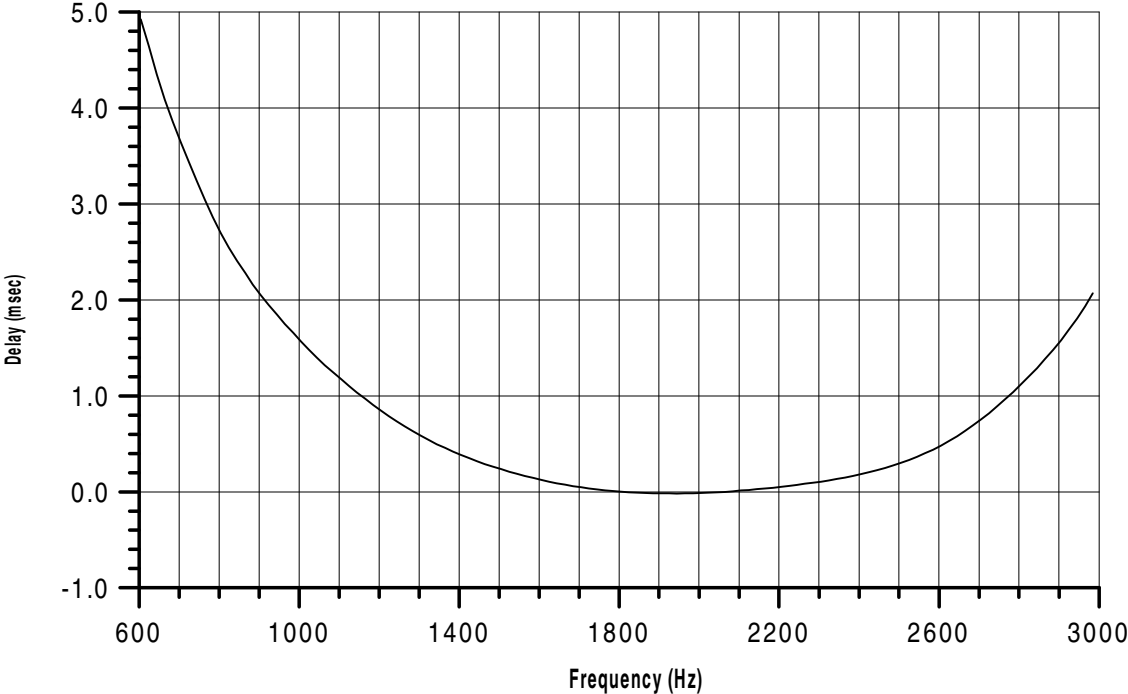

Figure 5-69. TAS JPN 6 Delay

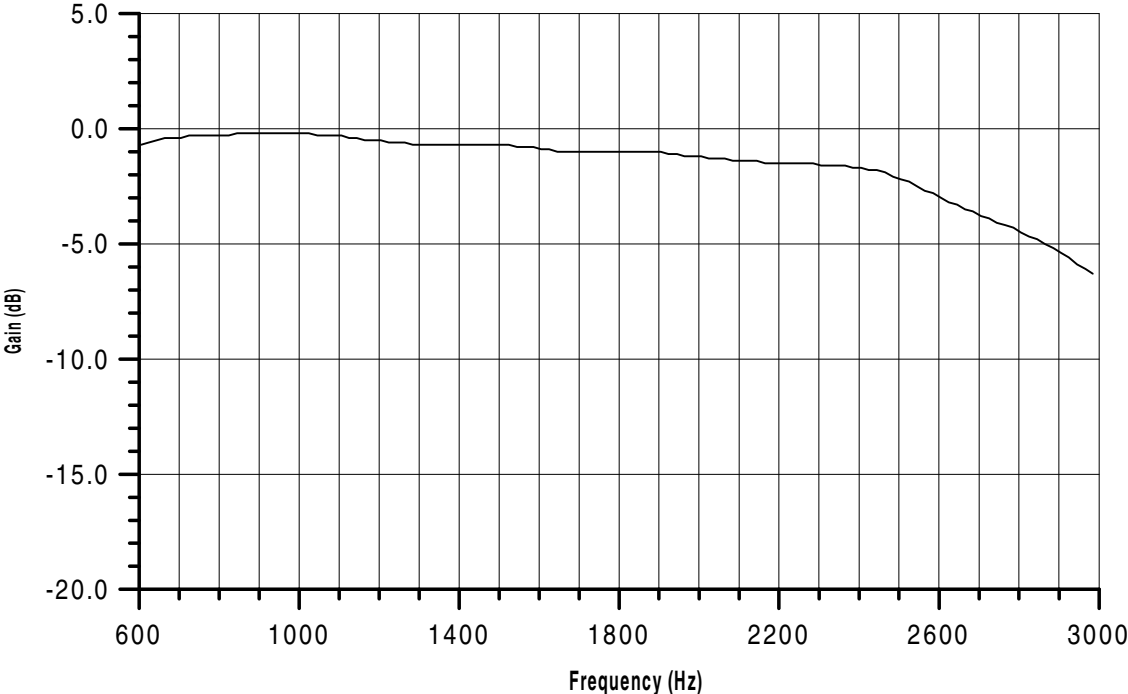

Figure 5-70. TAS JPN 7 Gain

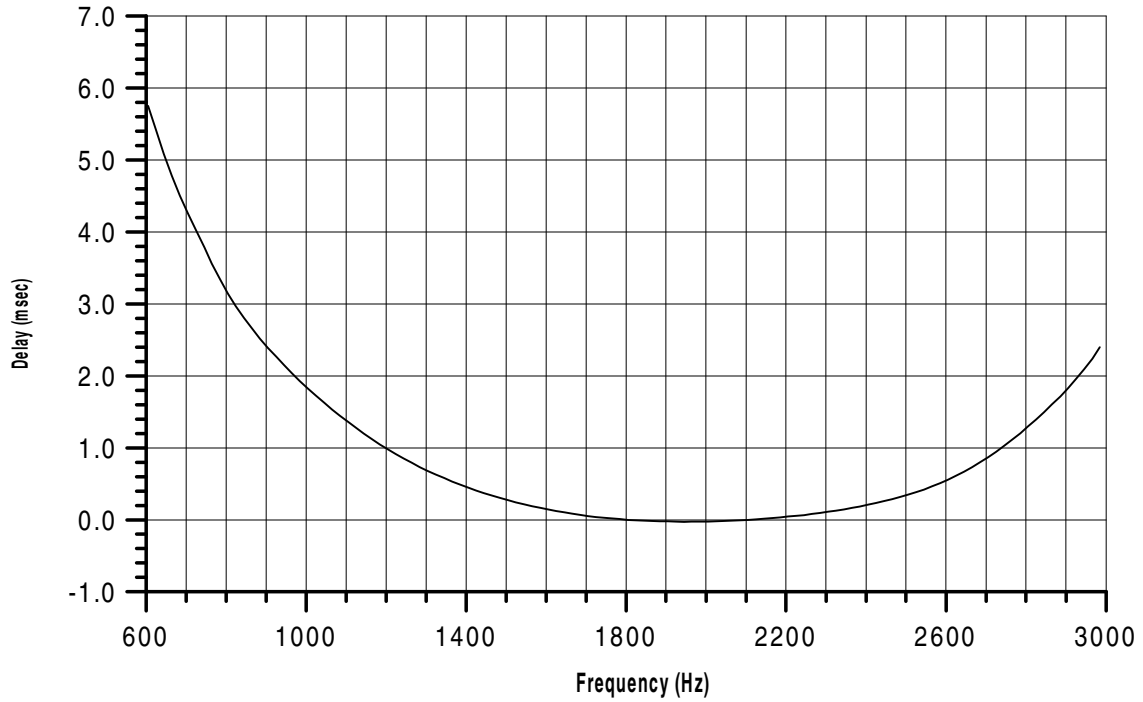

Figure 5-71. TAS JPN 7 Delay

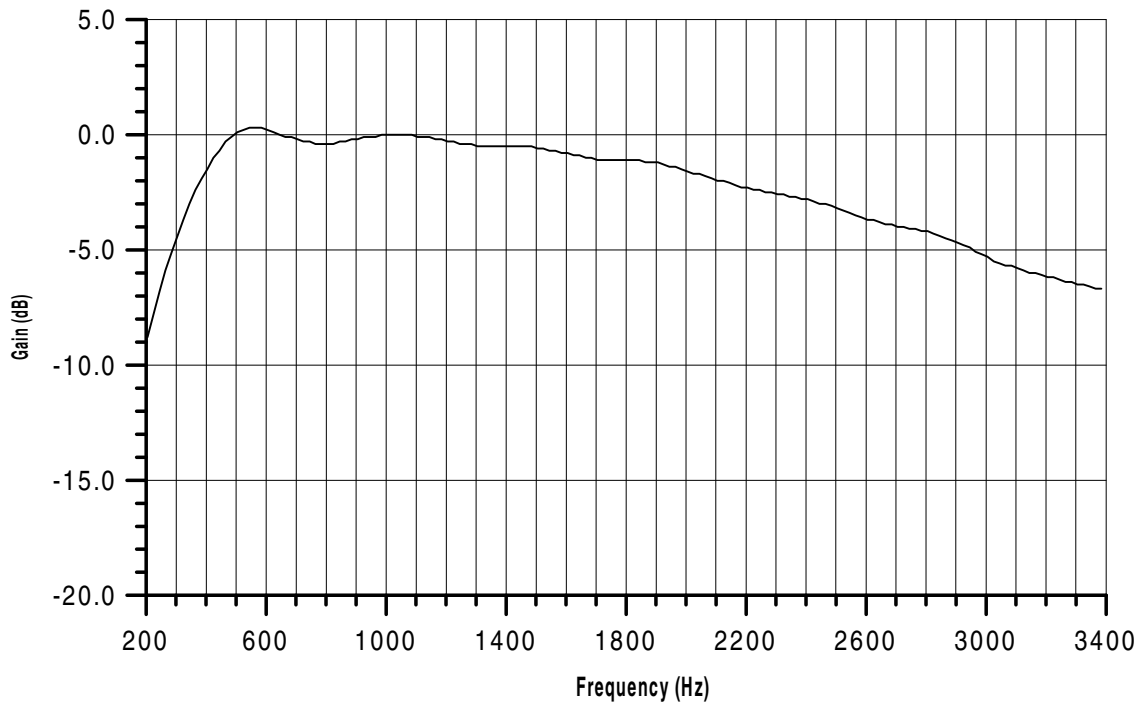

Figure 5-72. TAS CCITT R28 Gain

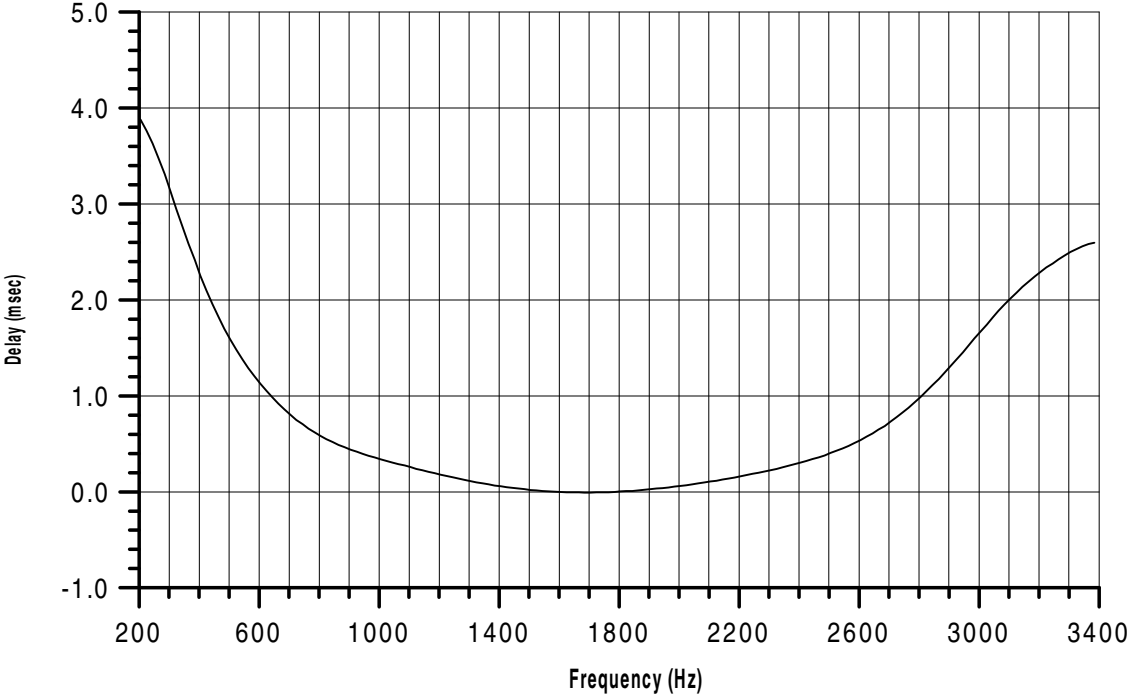

Figure 5-73 TAS CCITT R28 Delay

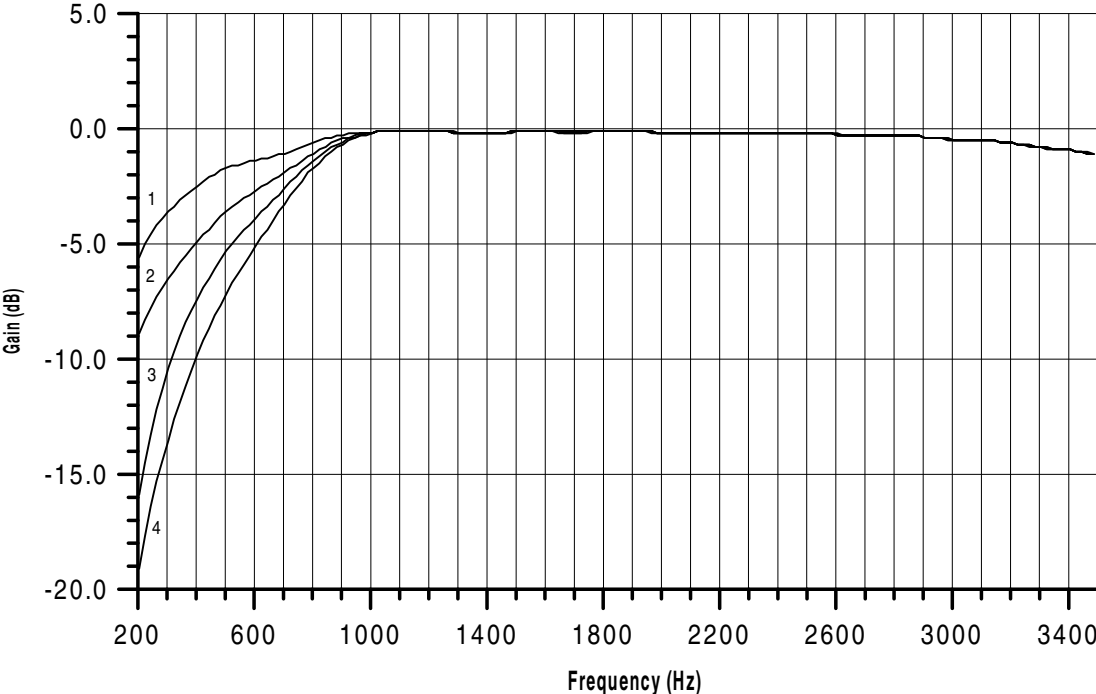

Figure 5-74. TAS LF Gain Curves 1-4

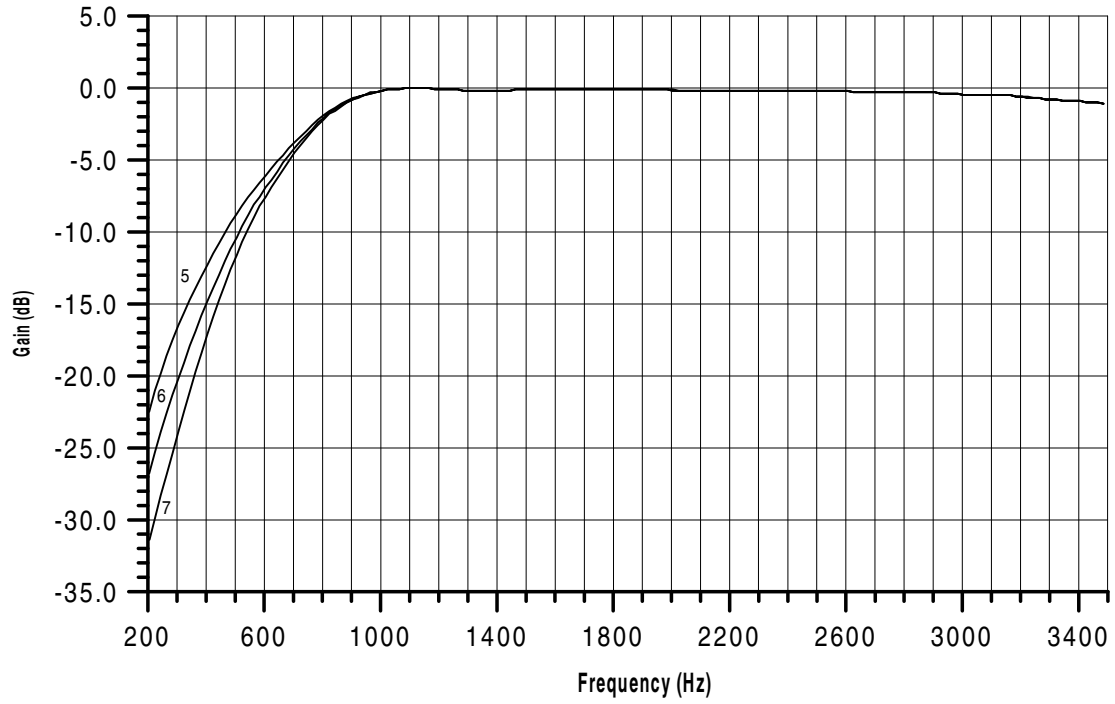

Figure 5-75. TAS LF Gain Curves 5-7

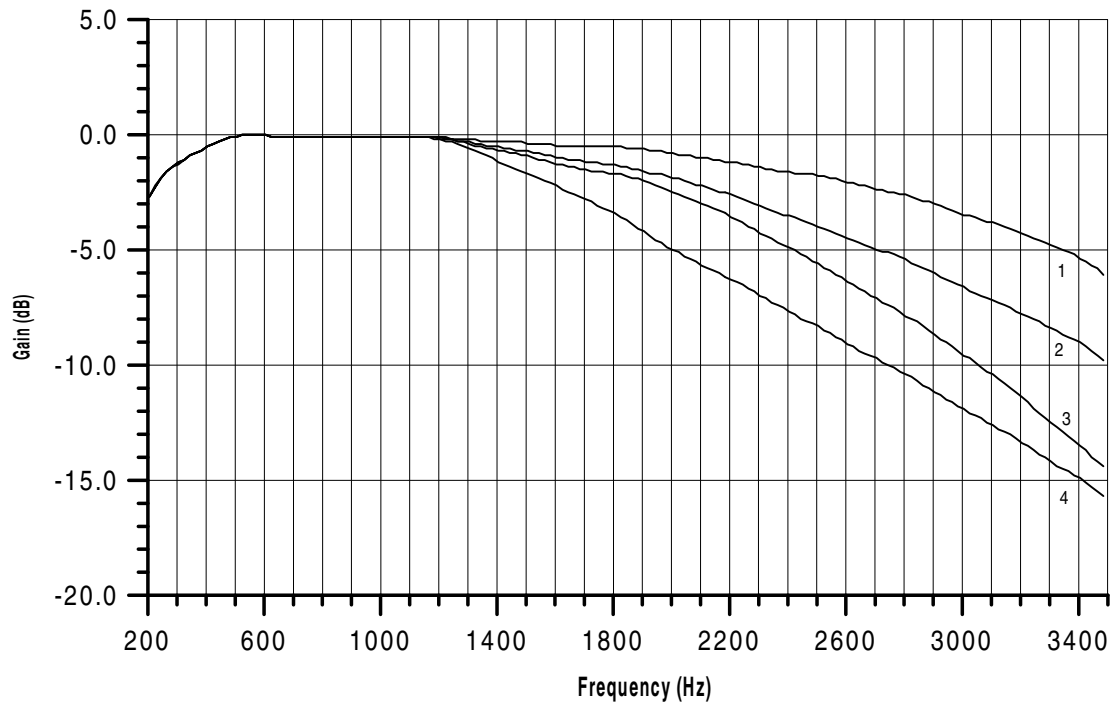

Figure 5-76. TAS HF Gain Curves 1-4

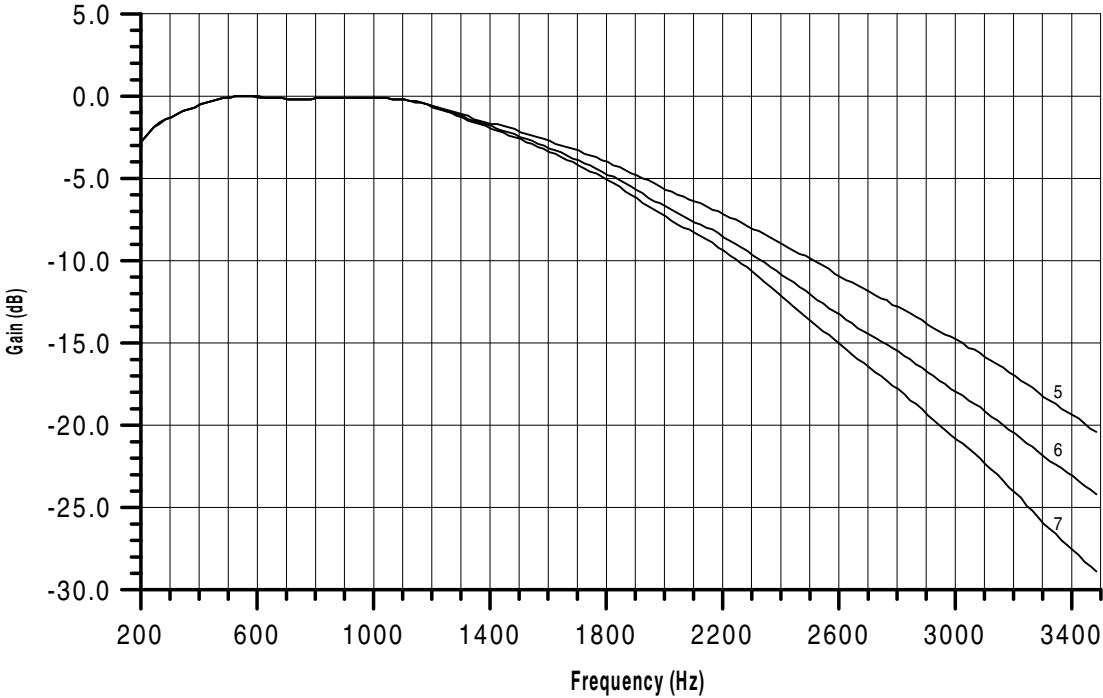

Figure 5-77. TAS HF Gain Curves 5-7

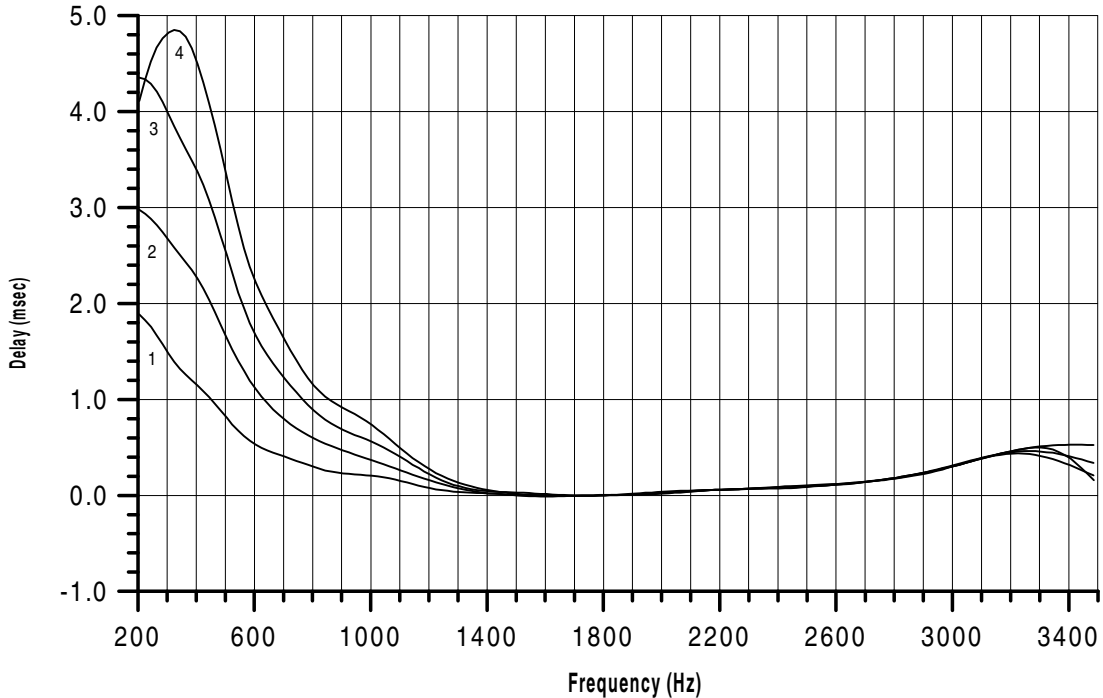

Figure 5-78. TAS LF Delay Curves 1-4

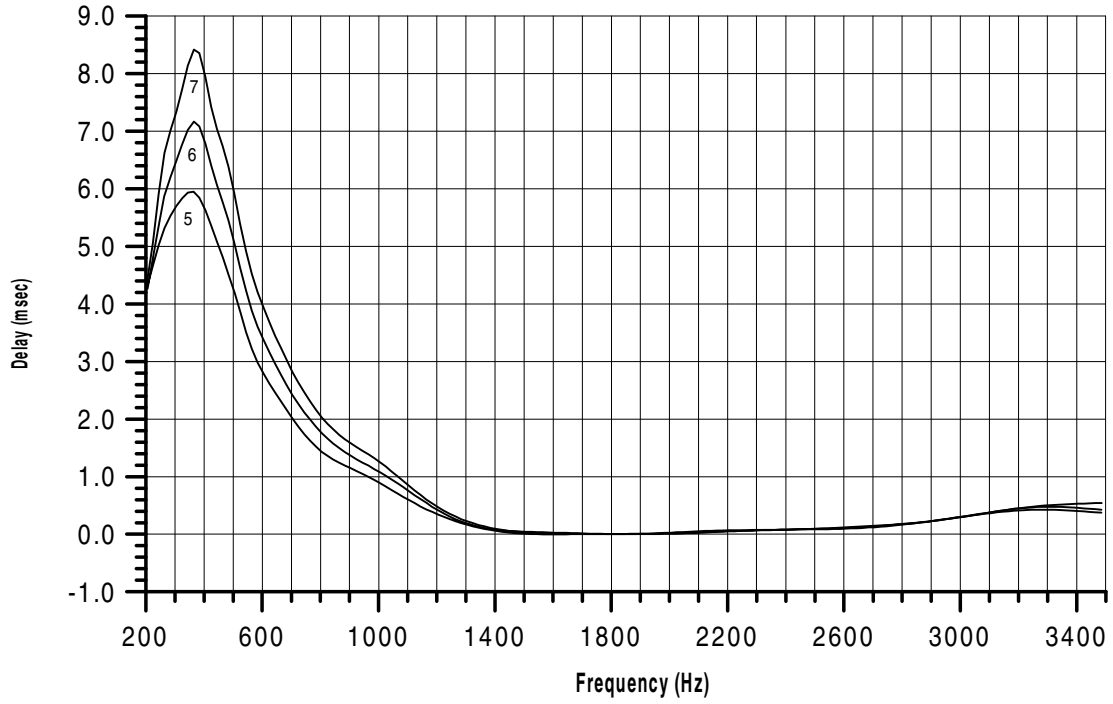

Figure 5-79. TAS LF Delay Curves 5-7

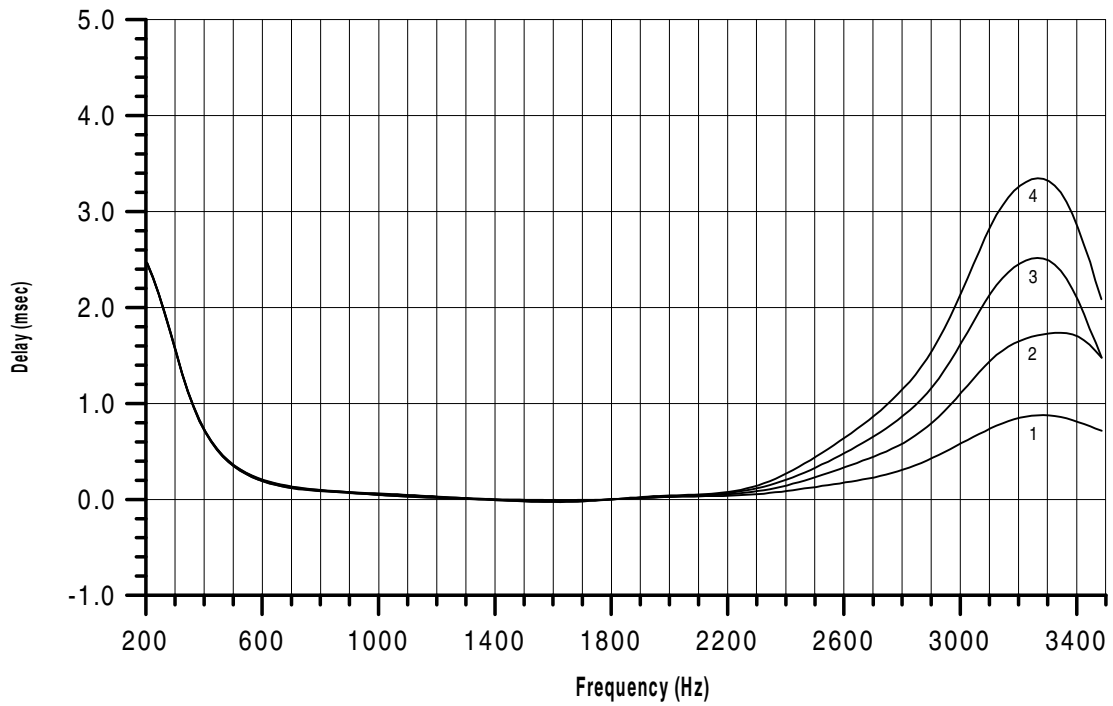

Figure 5-80. TAS HF Delay Curves 1-4

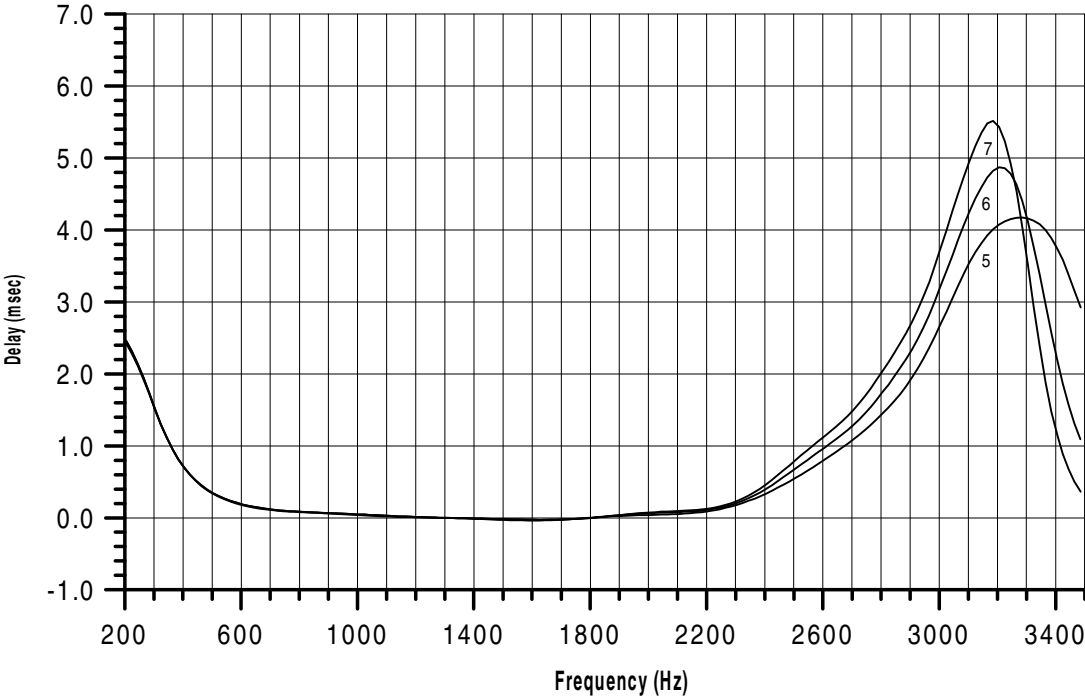

Figure 5-81. TAS HF Delay Curves 5-7

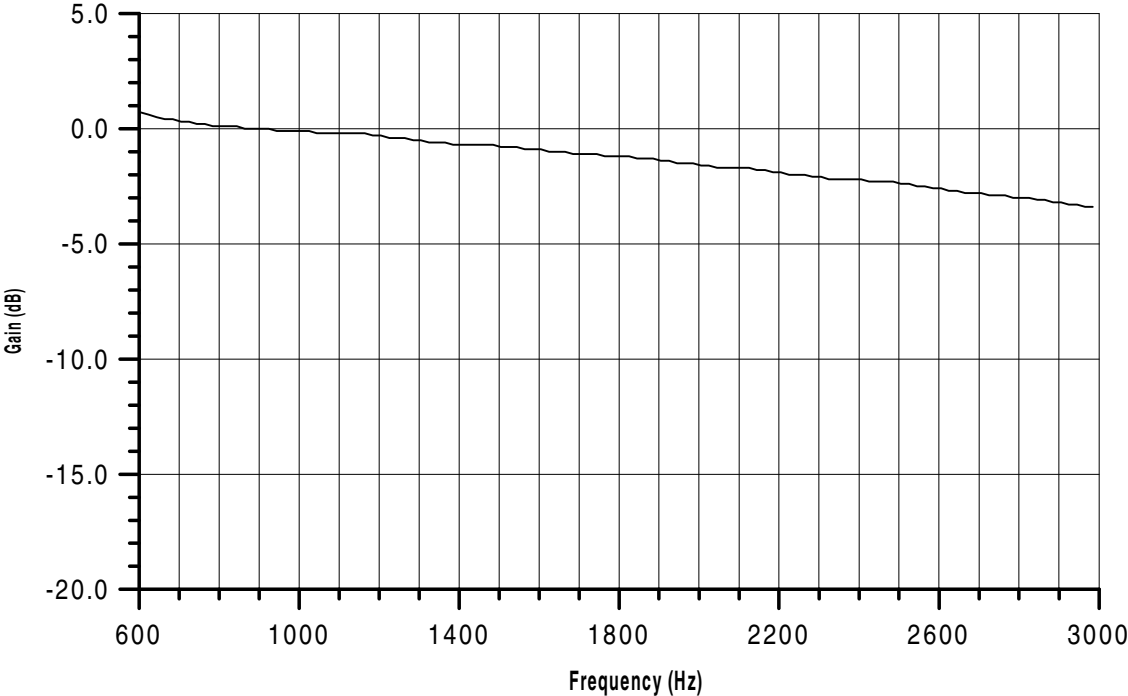

Figure 5-82. TAS JPN LP\_4 dB Gain

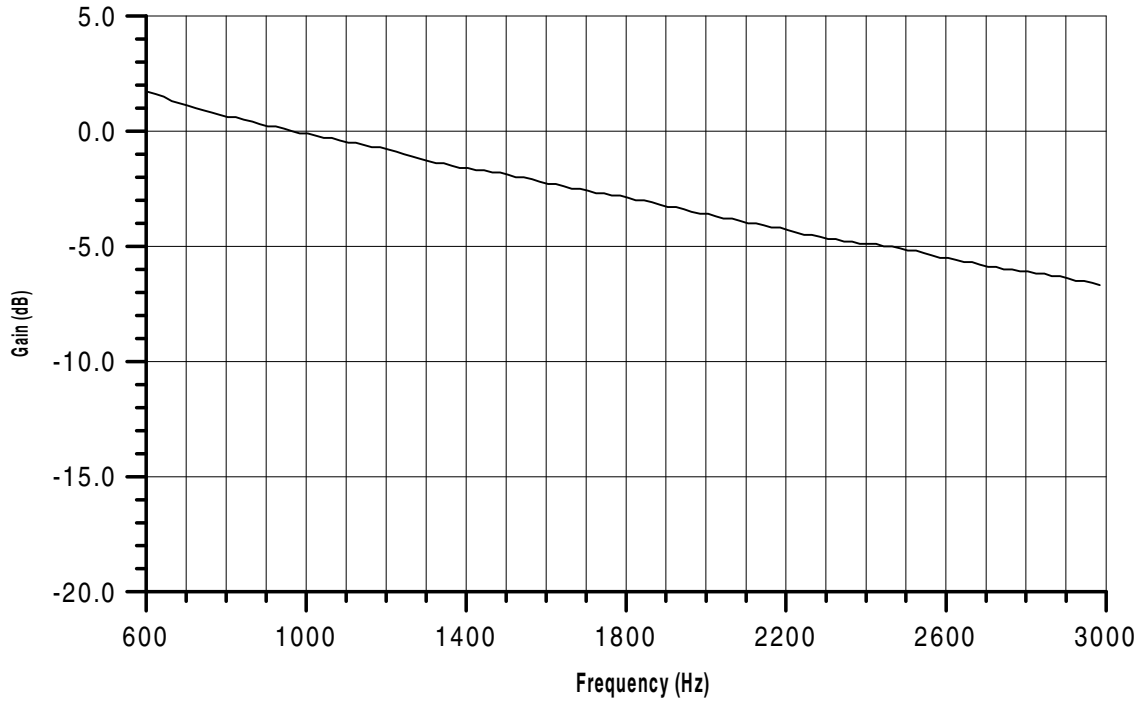

Figure 5-83. TAS JPN LP\_8 dB Gain

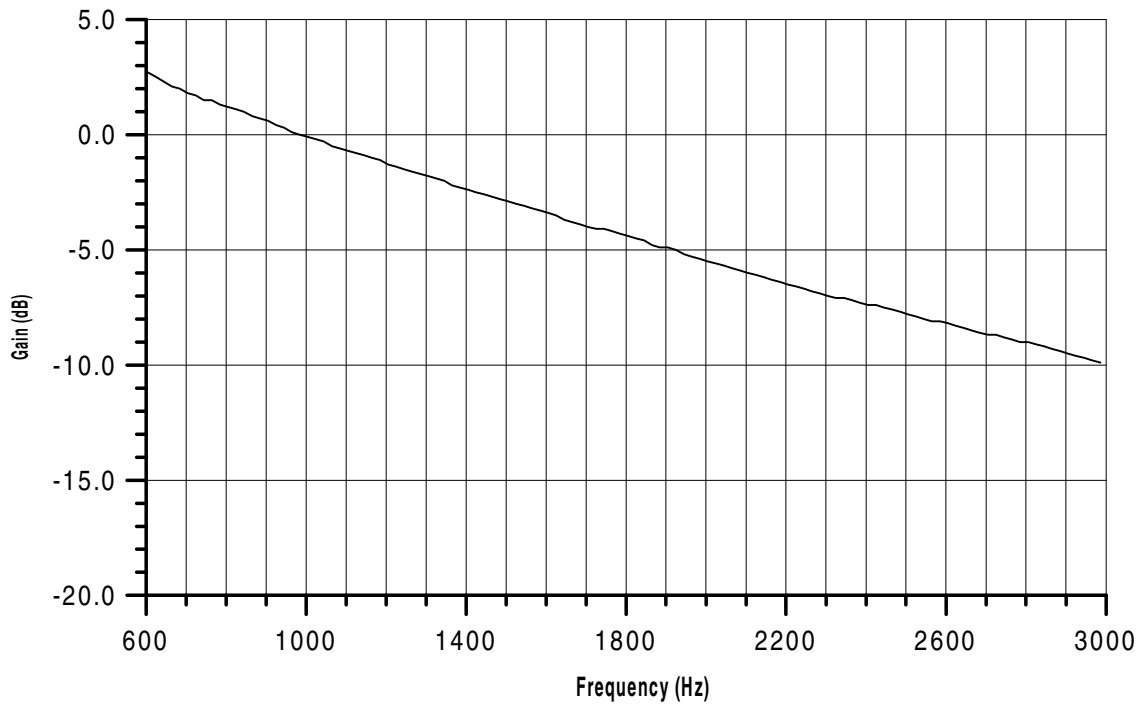

Figure 5-84. TAS JPN LP\_12 dB Gain



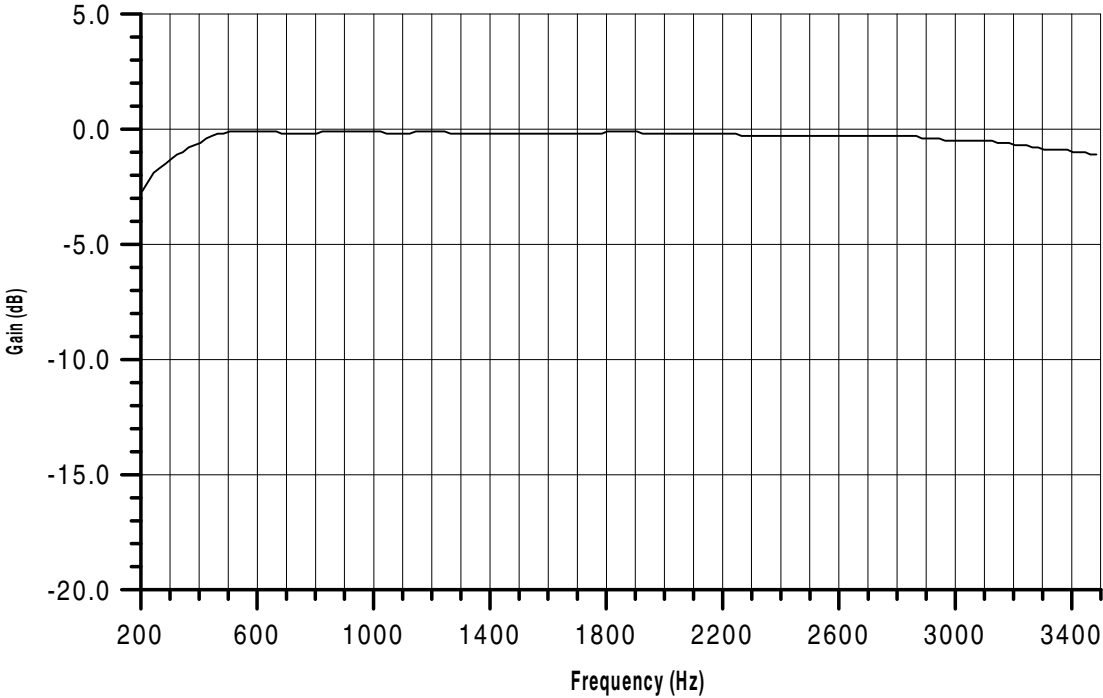

Figure 5-85. TAS French Line 1 Gain

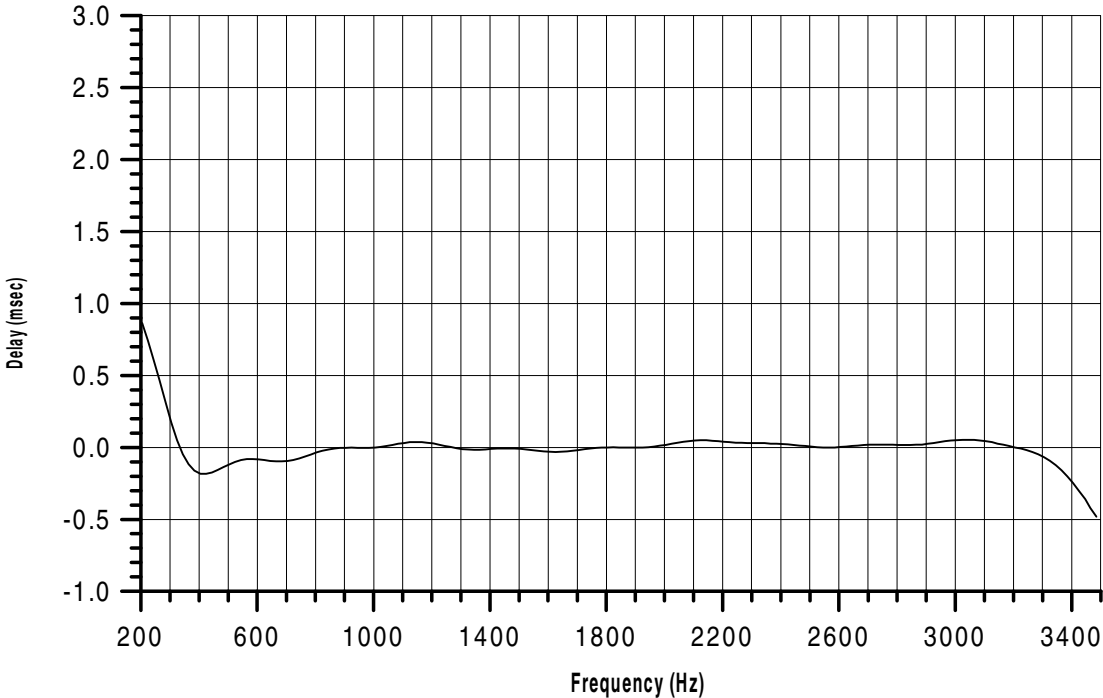

Figure 5-86. TAS French Line 1 Delay

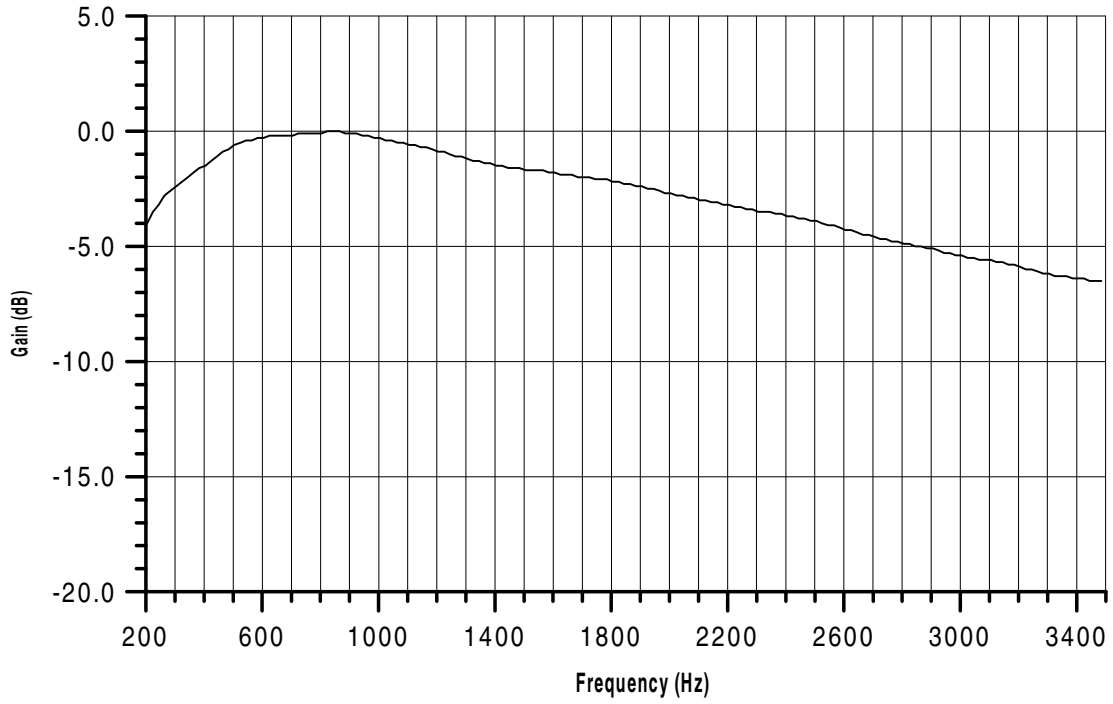

Figure 5-87. TAS French Line 2 Gain

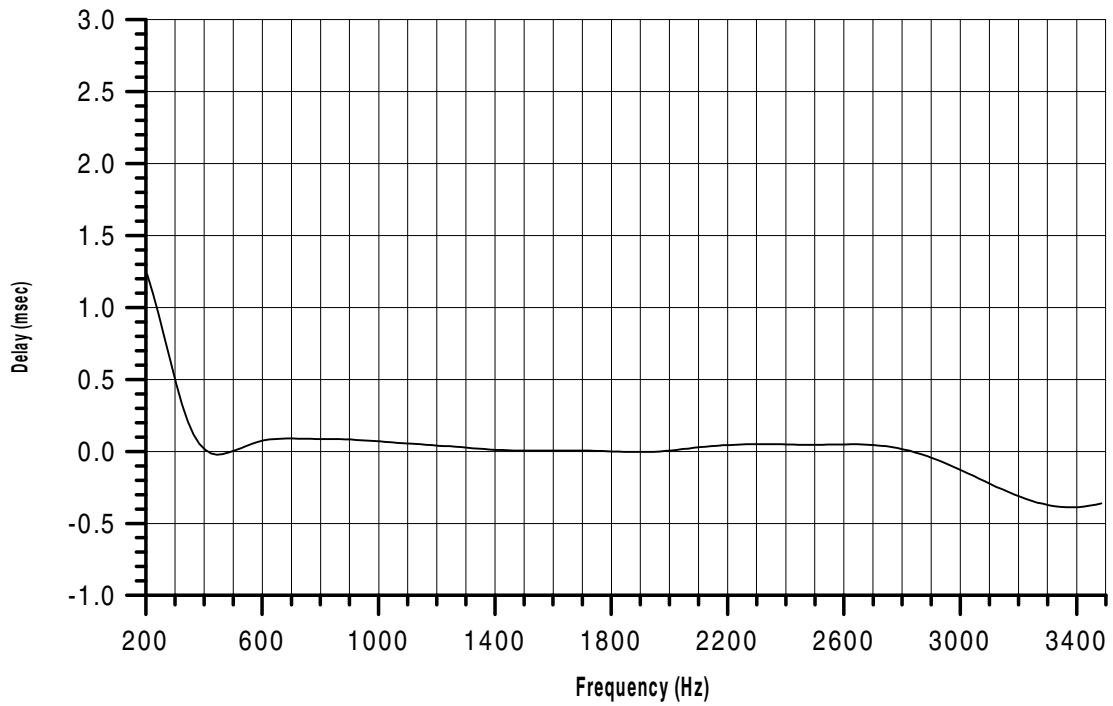

Figure 5-88. TAS French Line 2 Delay

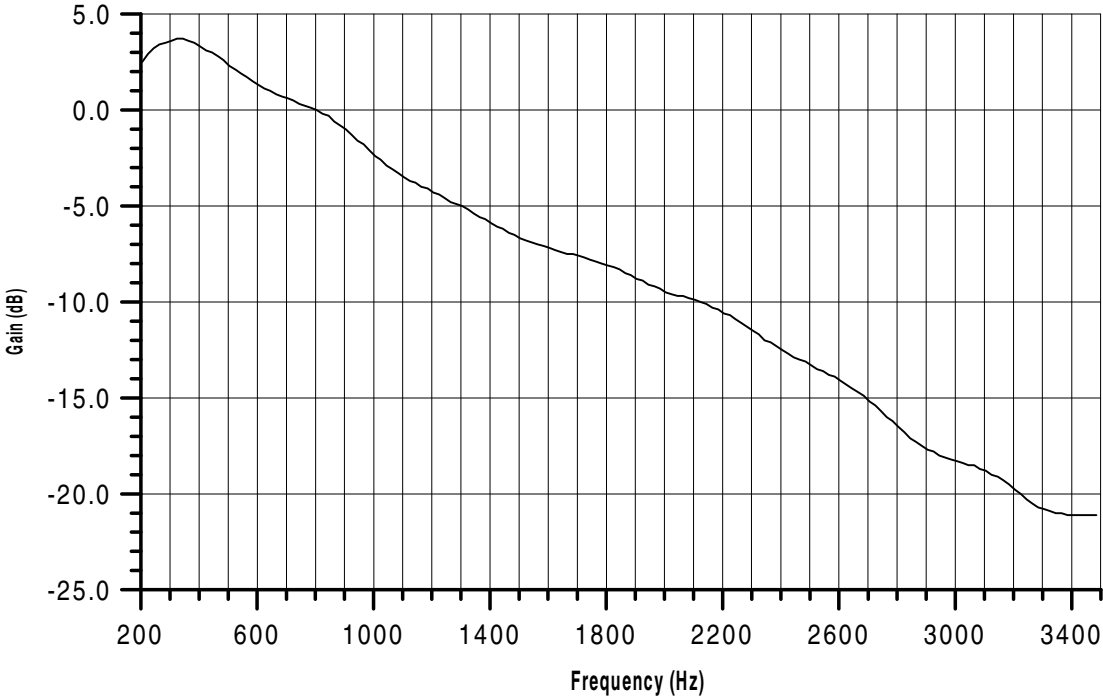

Figure 5-89. TAS French Line 3 Gain

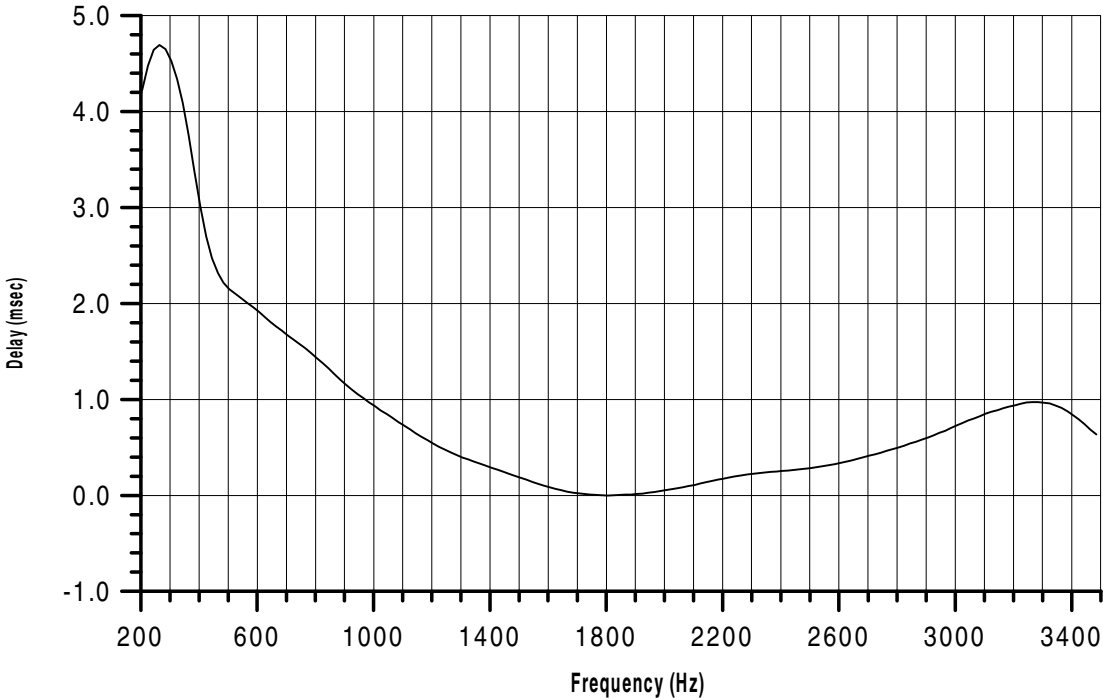

Figure 5-90. TAS French Line 3 Delay

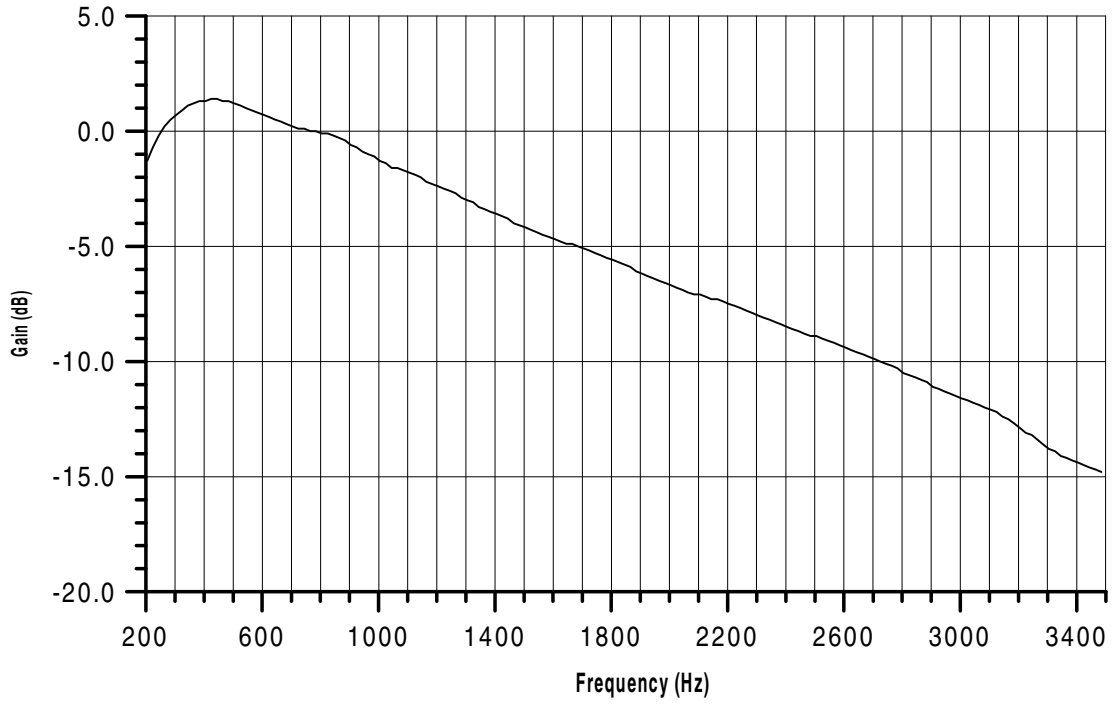

Figure 5-91. TAS French Line 4 Gain

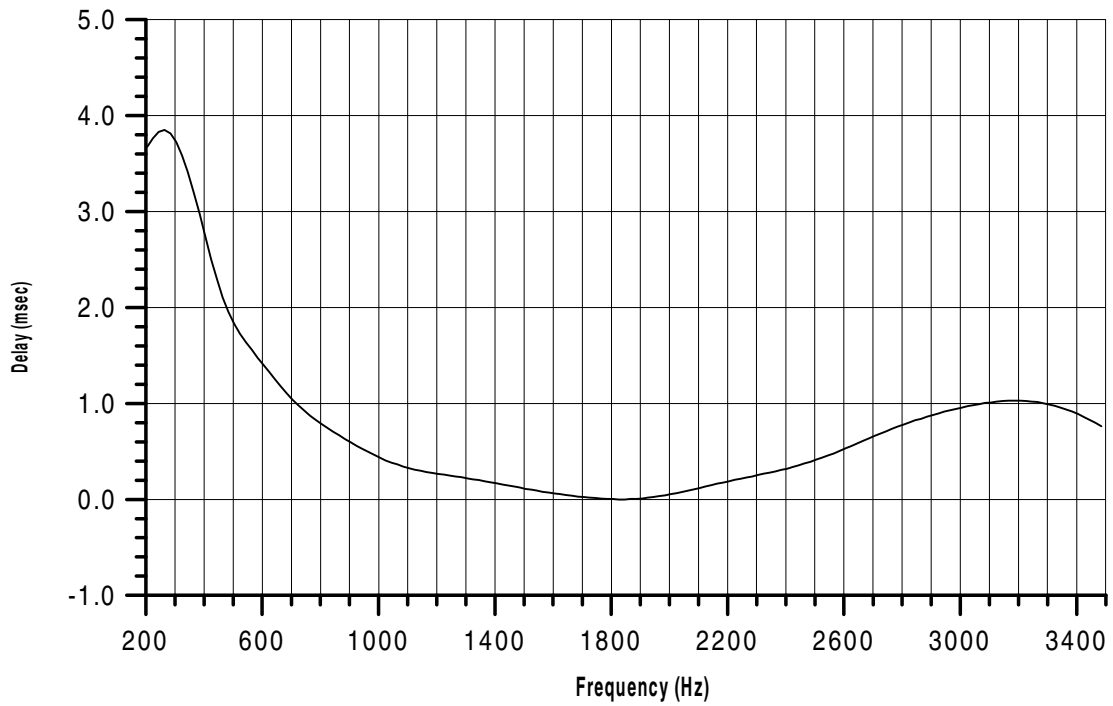

Figure 5-92. TAS French Line 4 Delay

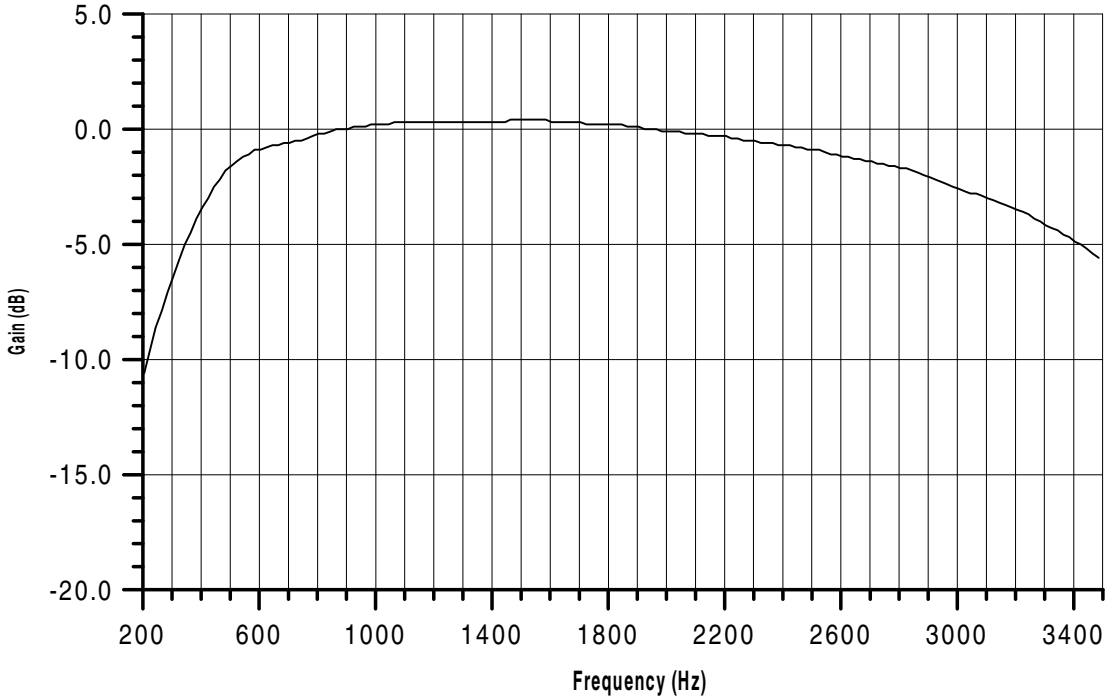

Figure 5-93. TAS NET 20 Line 1 Gain

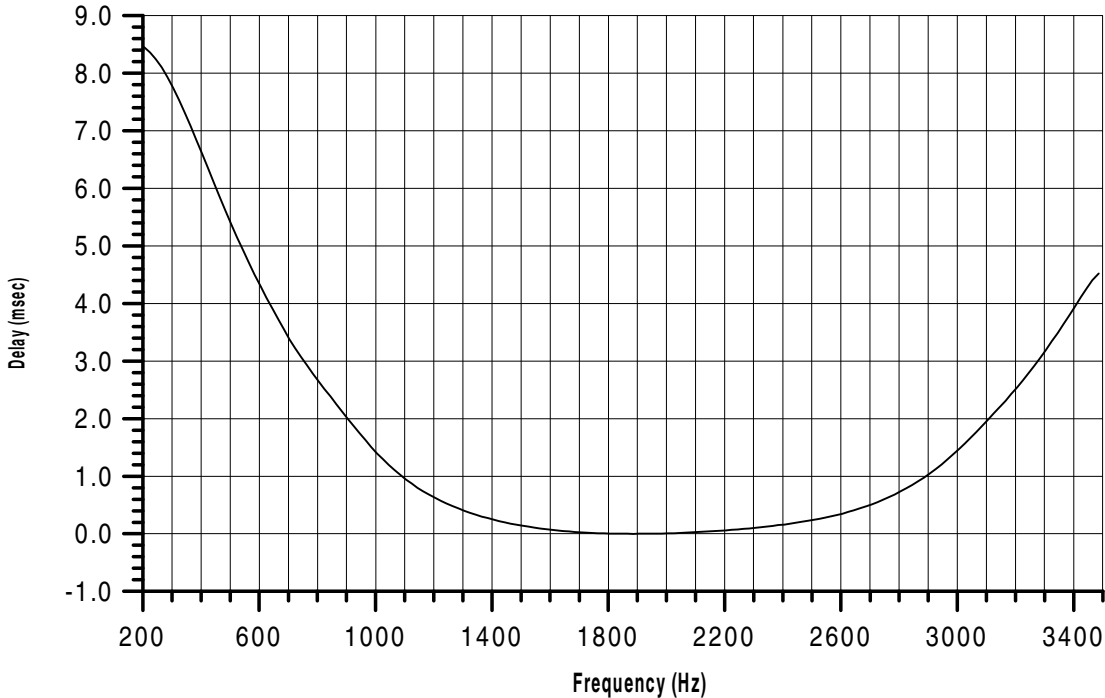

Figure 5-94. TAS NET 20 Line Delay

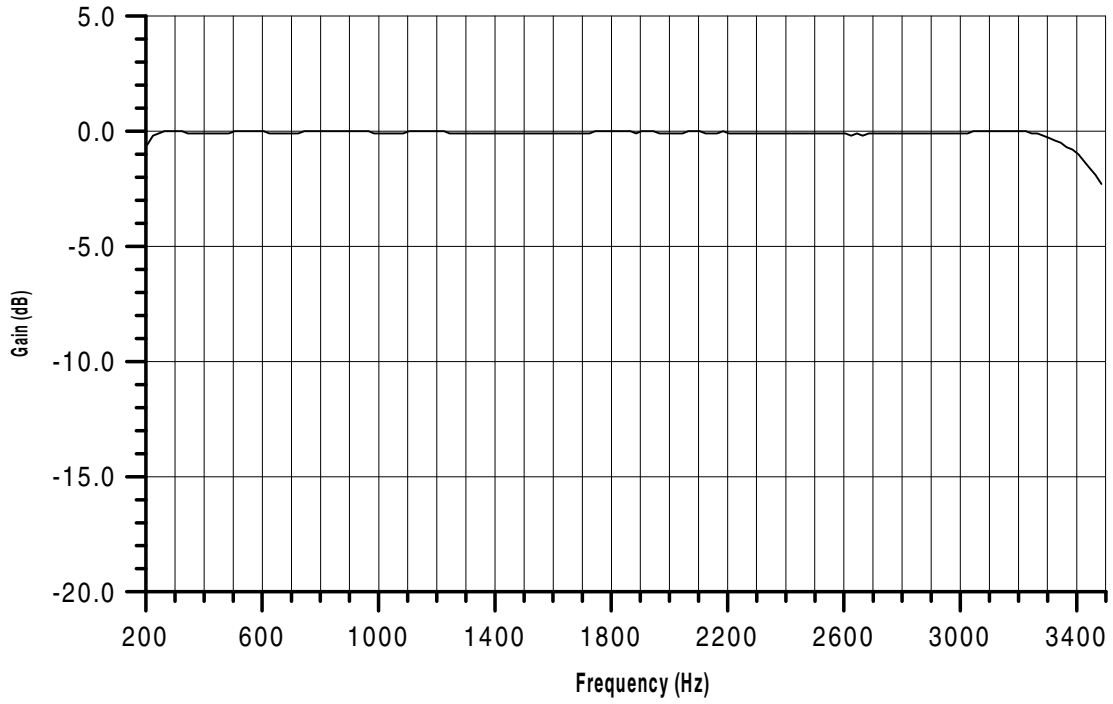

Figure 5-95. Gain Response of 1 TAS PCM/ADPCM Link

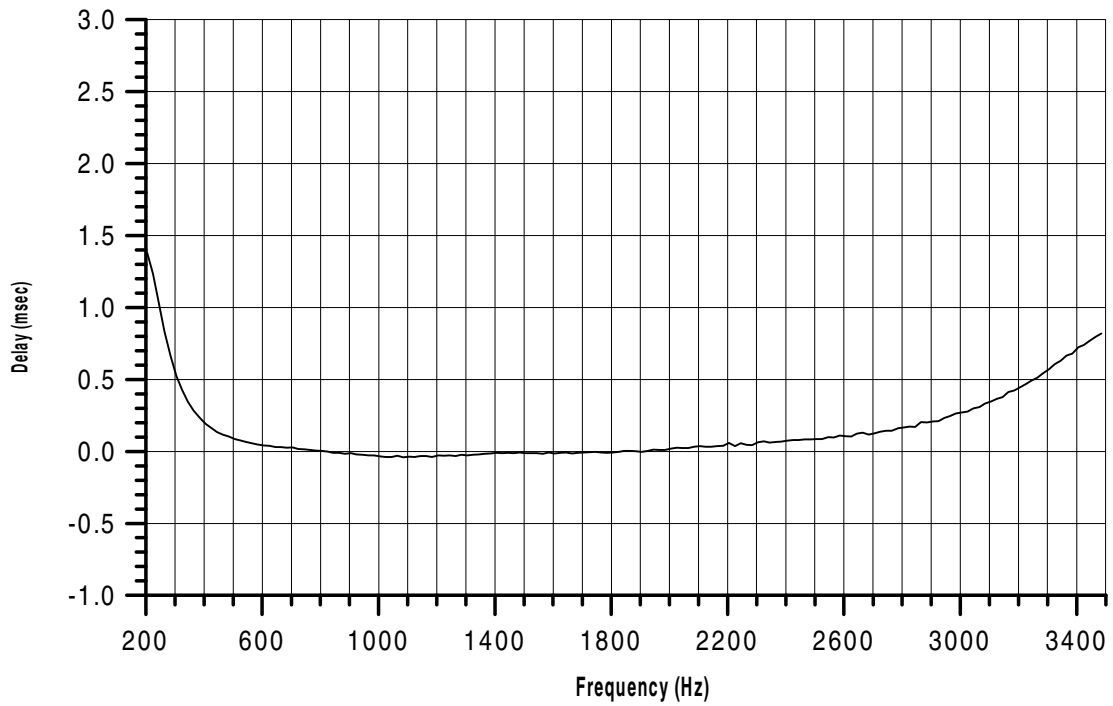

Figure 5-96. Delay Response of 1 TAS PCM/ADPCM Link

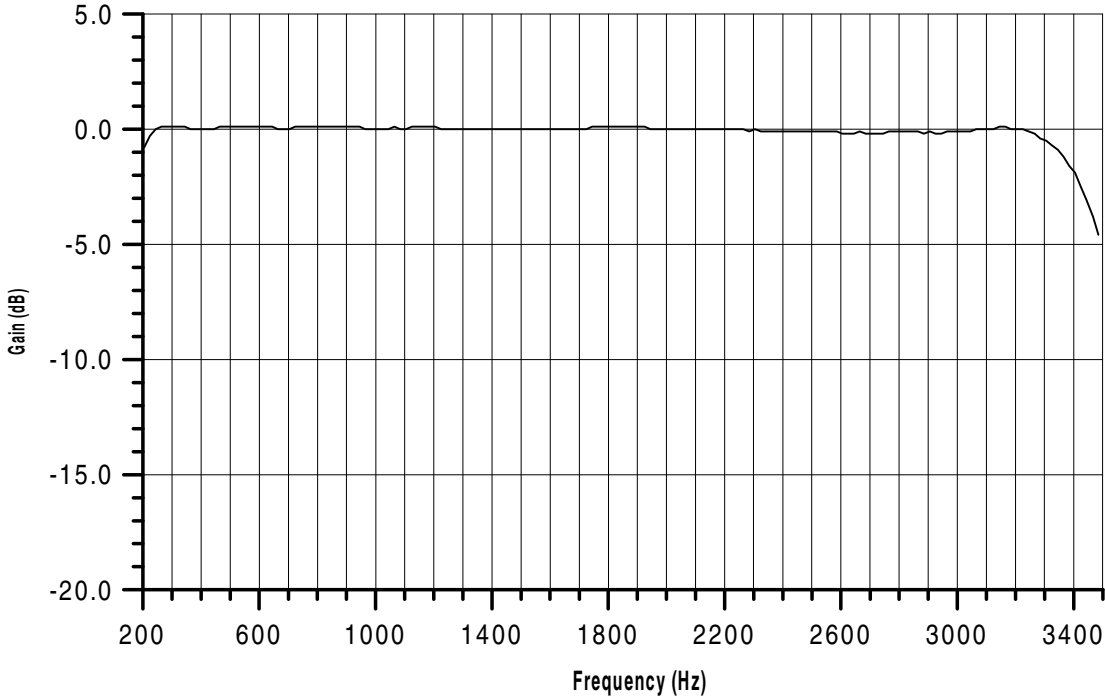

Figure 5-97. Gain Response of 2 TAS PCM/ADPCM Tandem Links

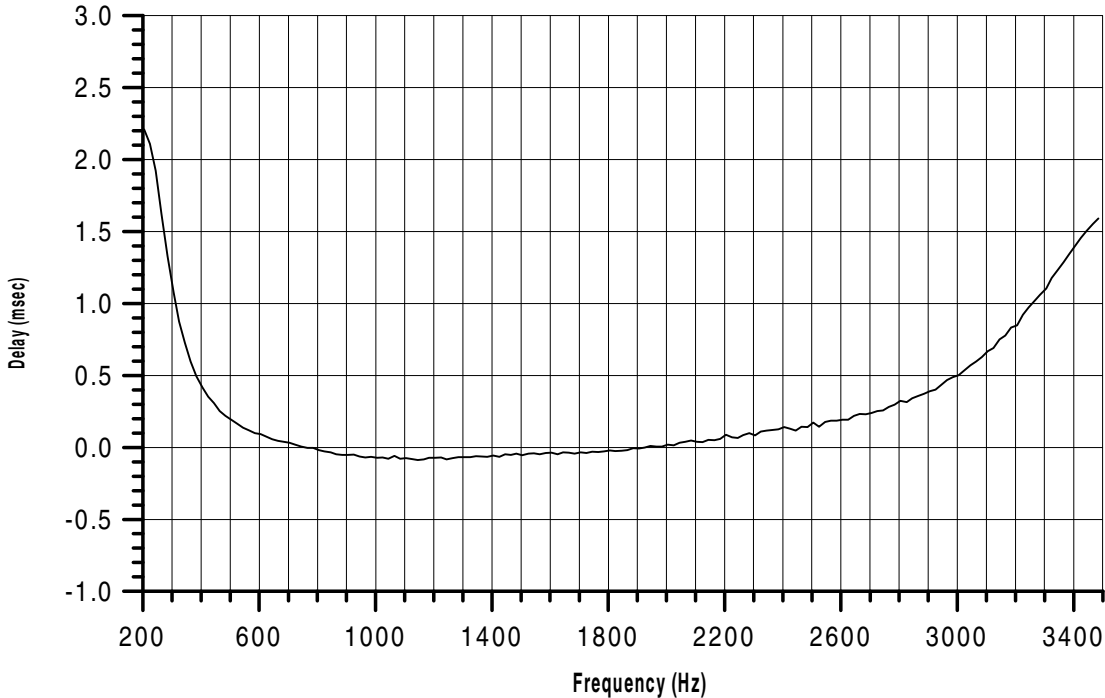

Figure 5-98. Delay Response of 2 TAS PCM/ADPCM Tandem Links

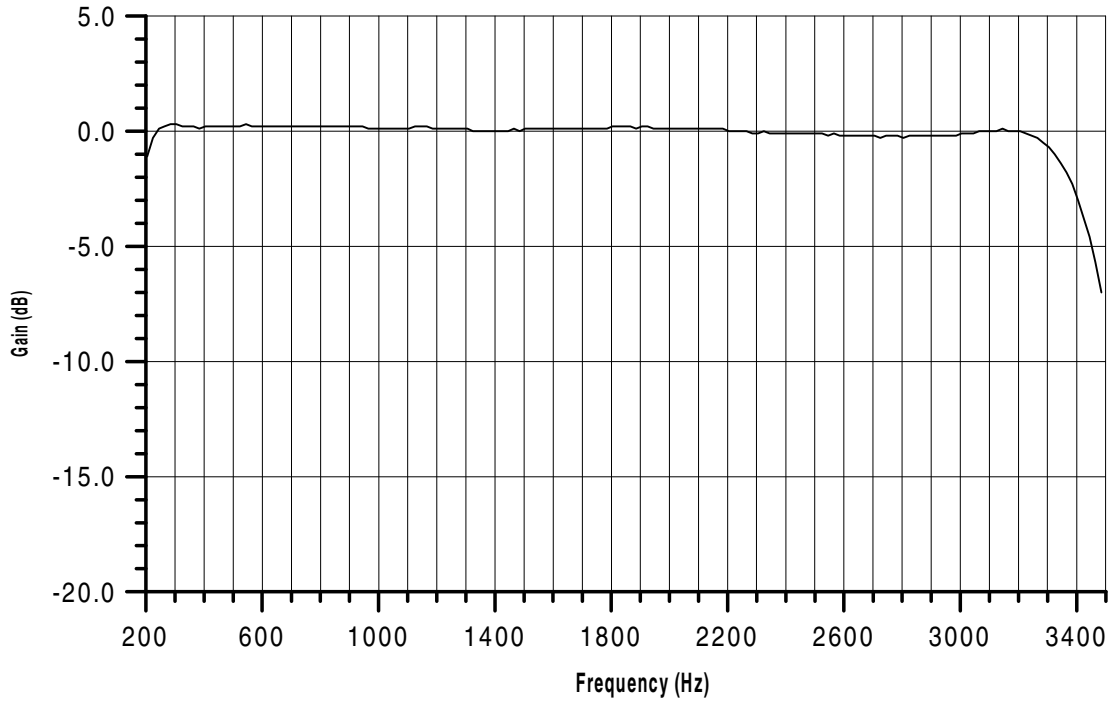

Figure 5-99. Gain Response of 3 TAS PCM/ADPCM Tandem Links

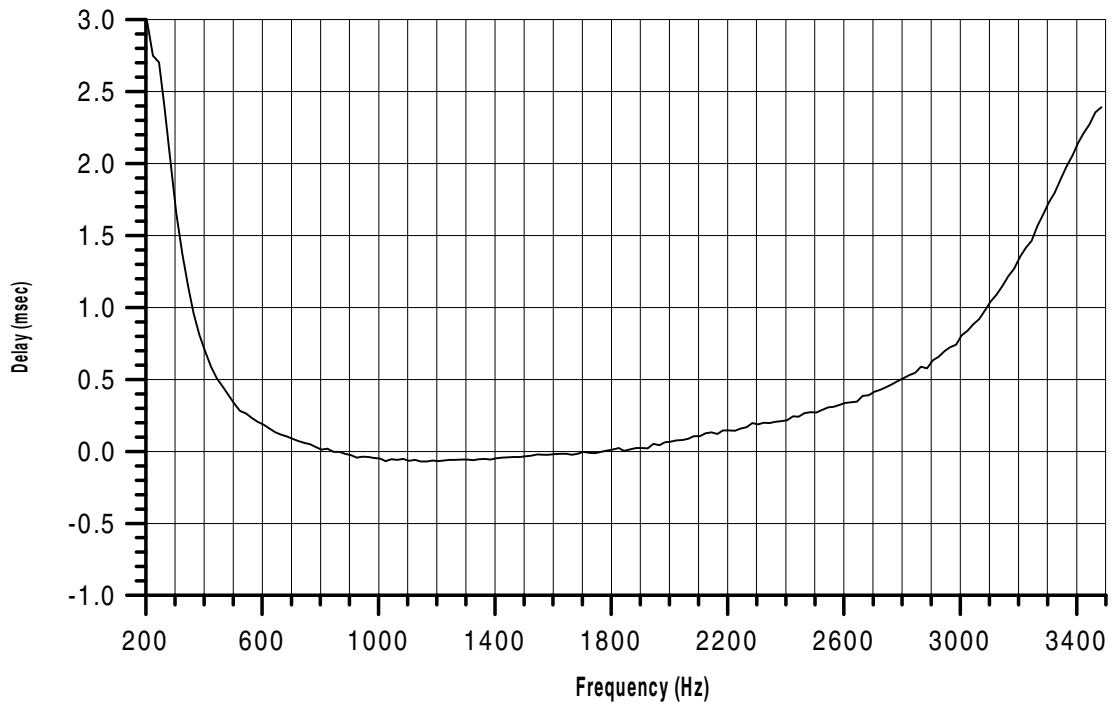

Figure 5-100. Delay Response of 3 TAS PCM/ADPCM Tandem Links



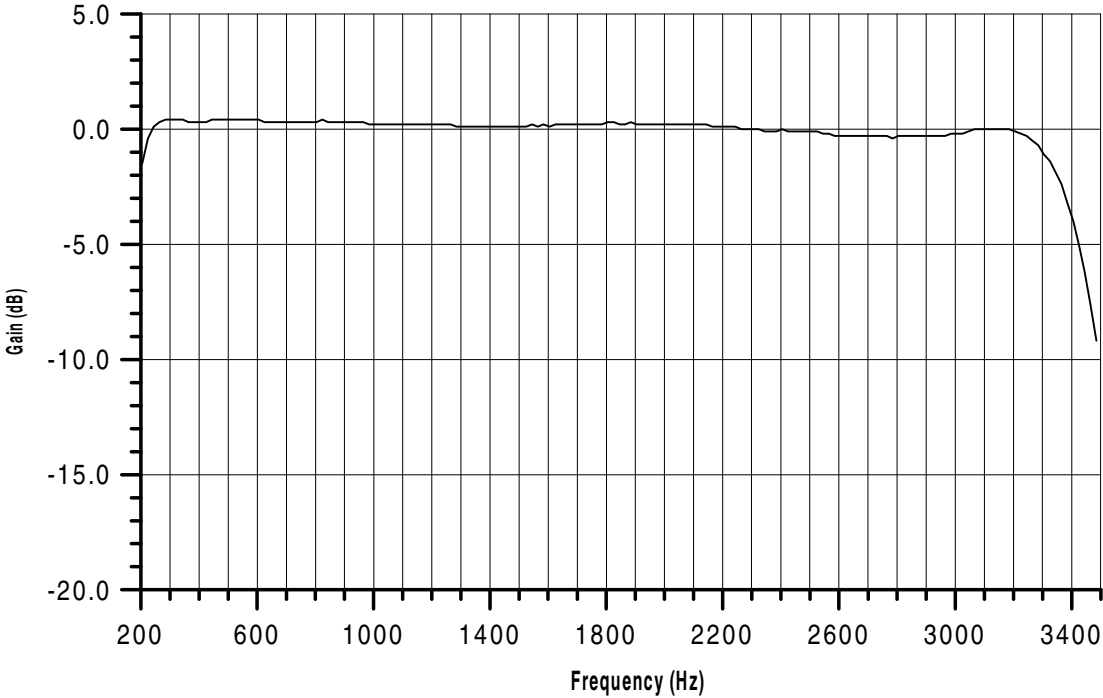

Figure 101. Gain Response of 4 TAS PCM/ADPCM Tandem Links

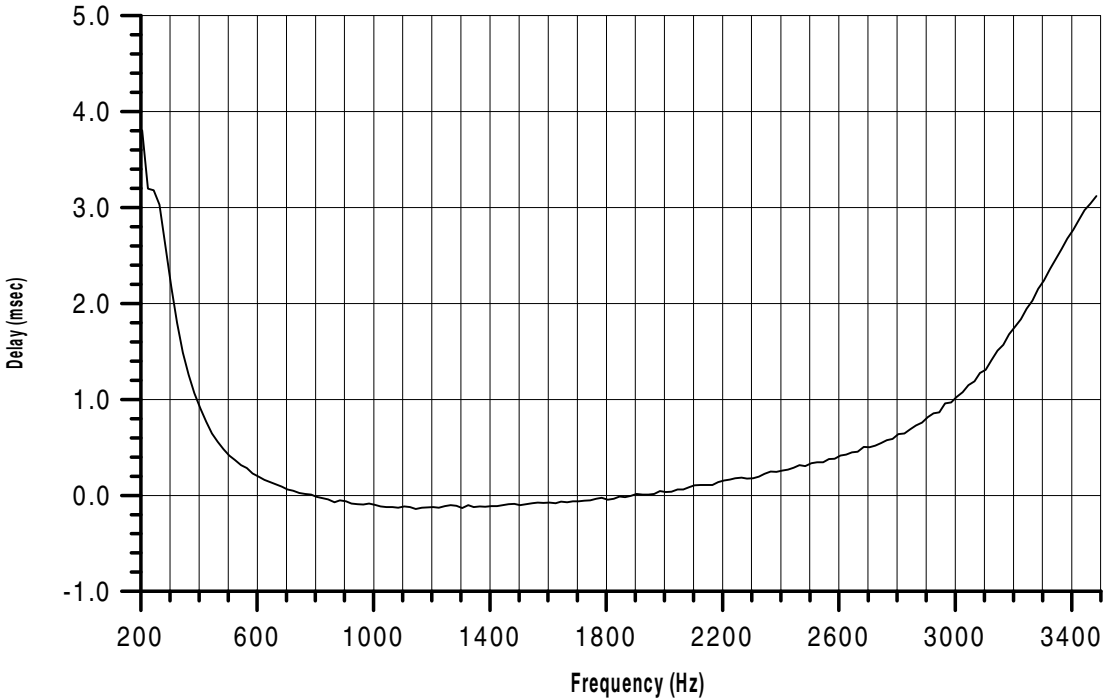

Figure 102. Delay Response of 4 TAS PCM/ADPCM Tandem Links

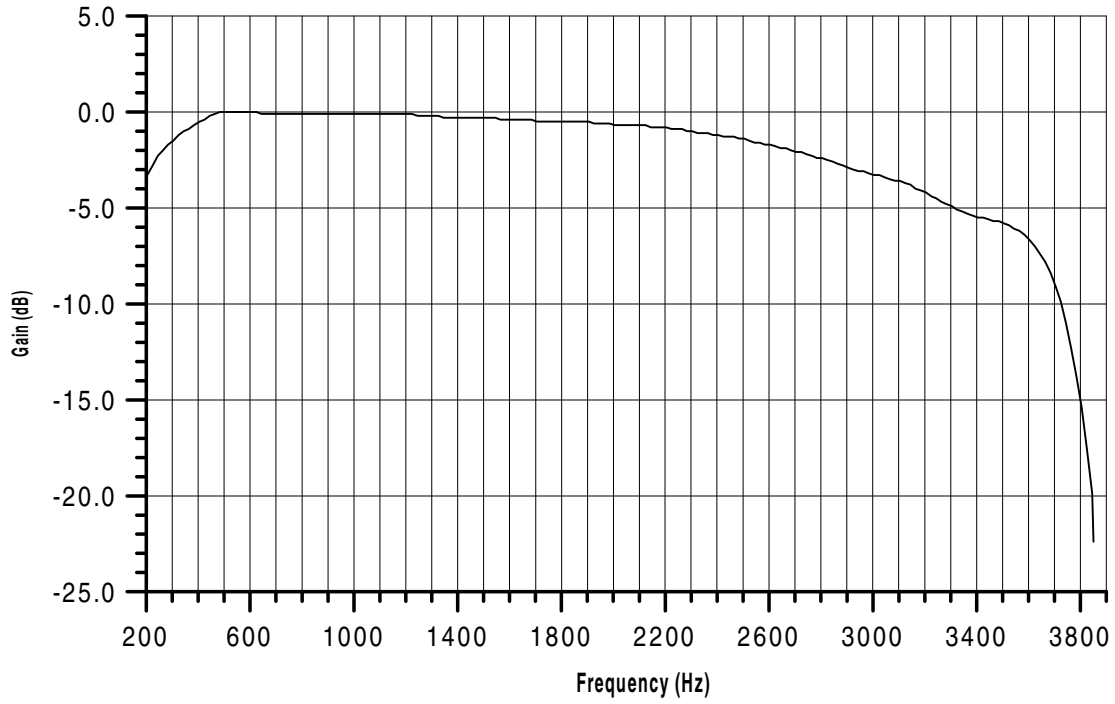

Figure 5-103. TAS Cable-1 Gain

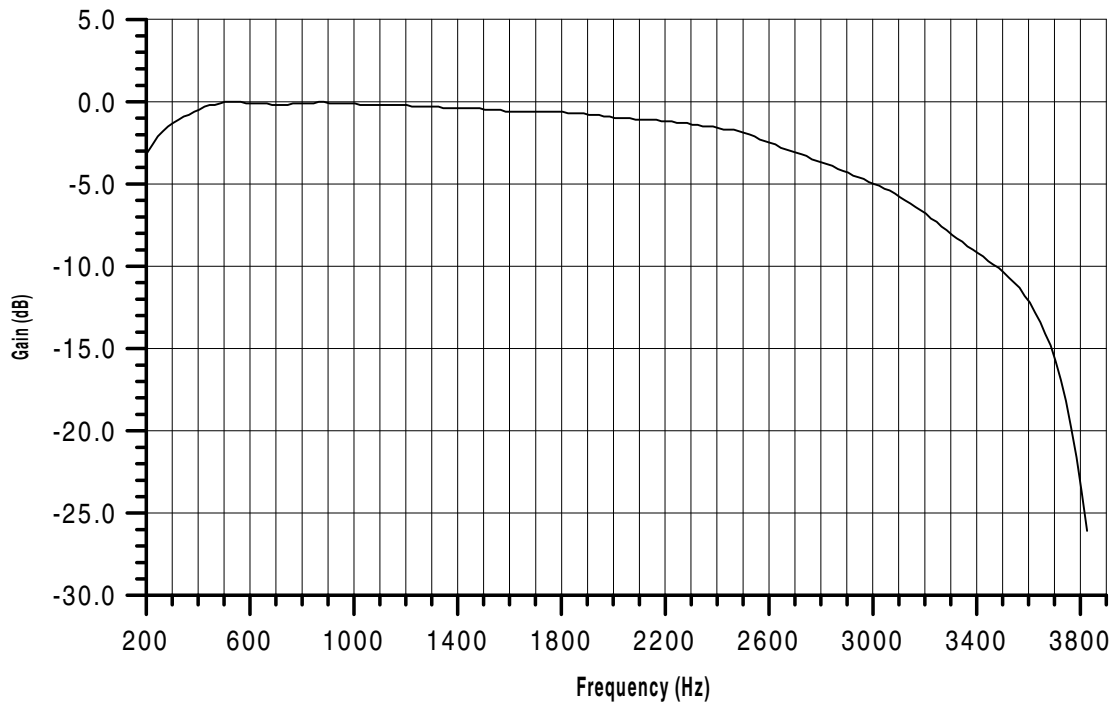

Figure 5-104. TAS Cable-2 Gain

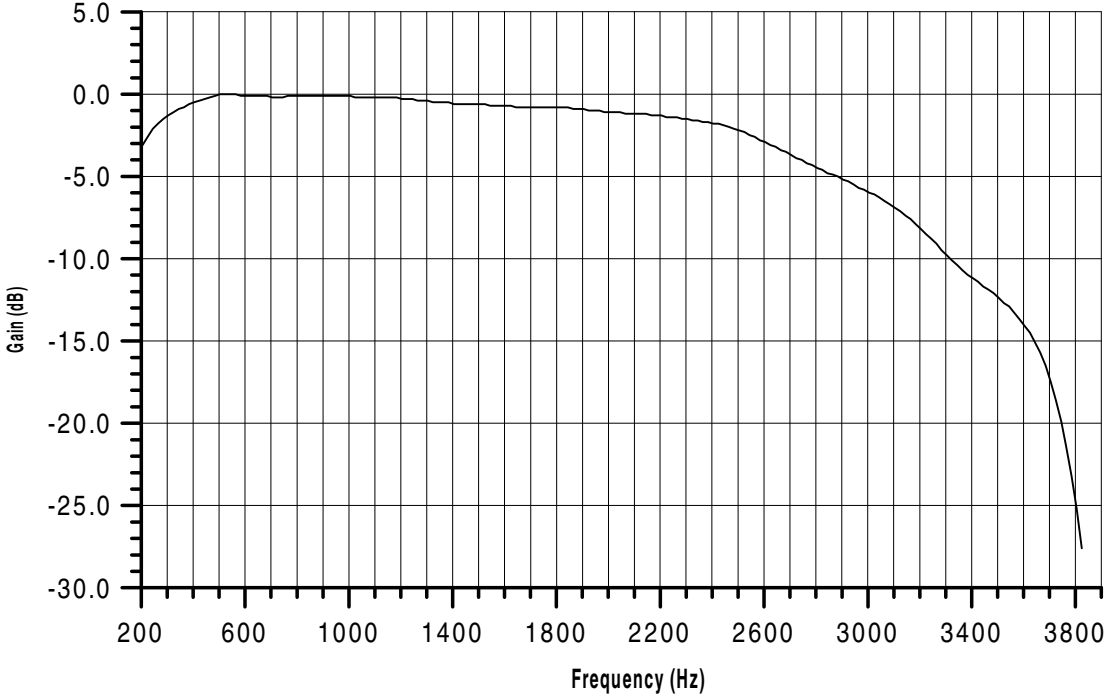

Figure 5-105. TAS Cable-3 Gain

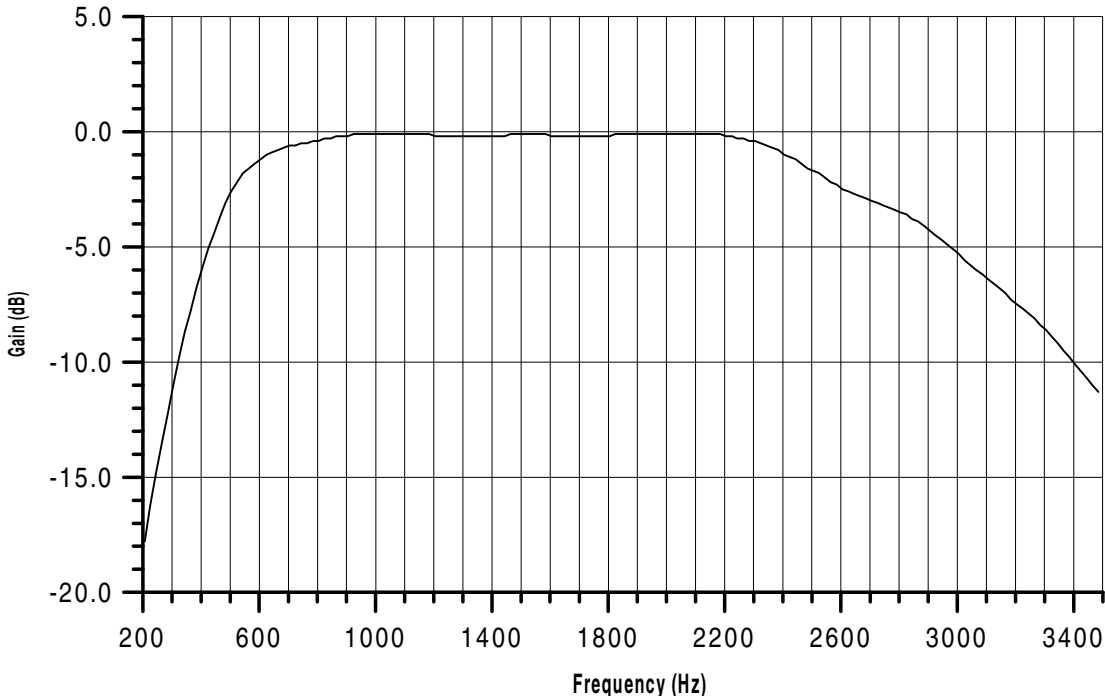
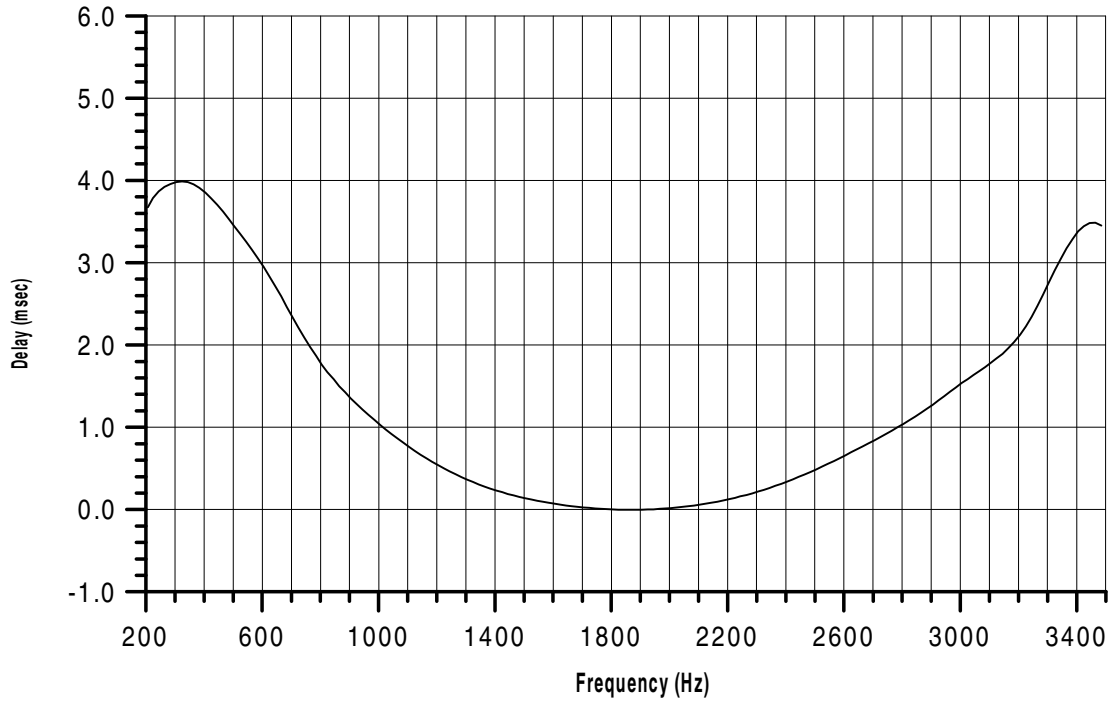
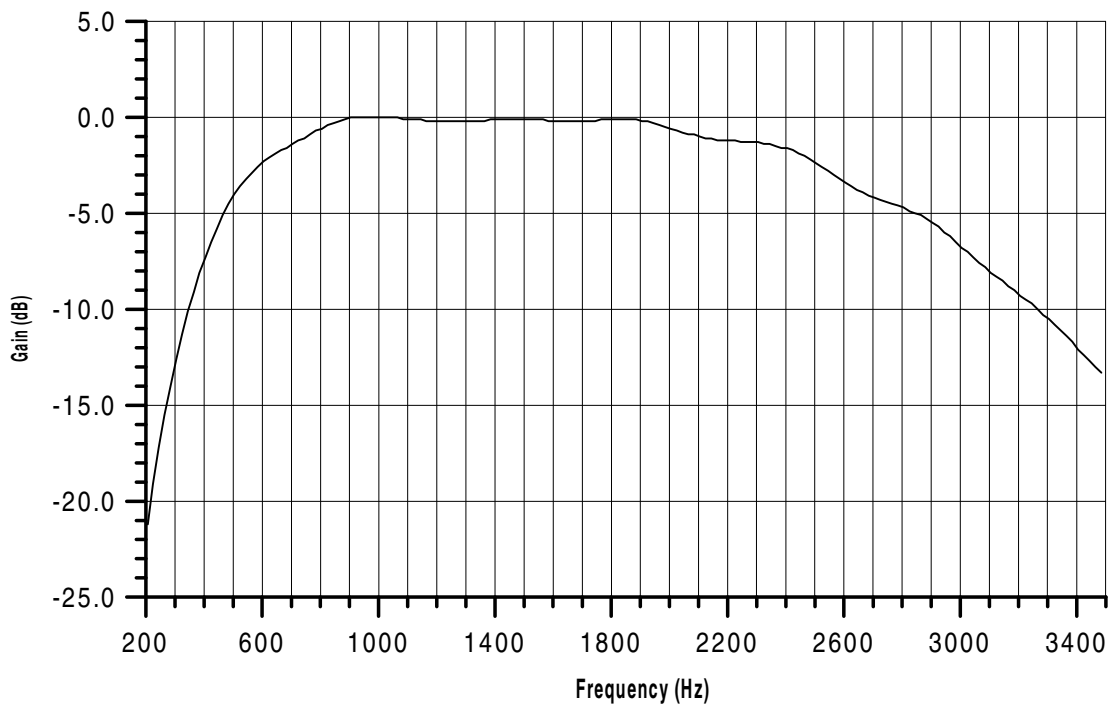

Figure 5-106. Asian 1 Gain



**Figure 5-107. Asian 1 Delay**



**Figure 5-108. Asian 2 Gain**

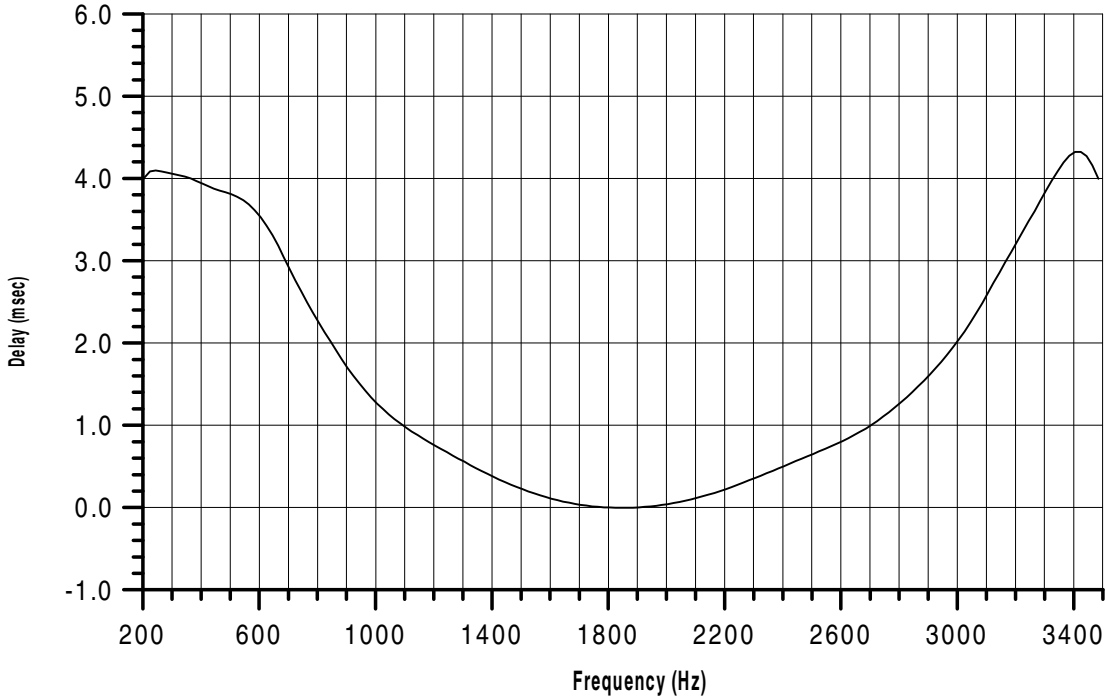

Figure 5-109. Asian 2 Delay

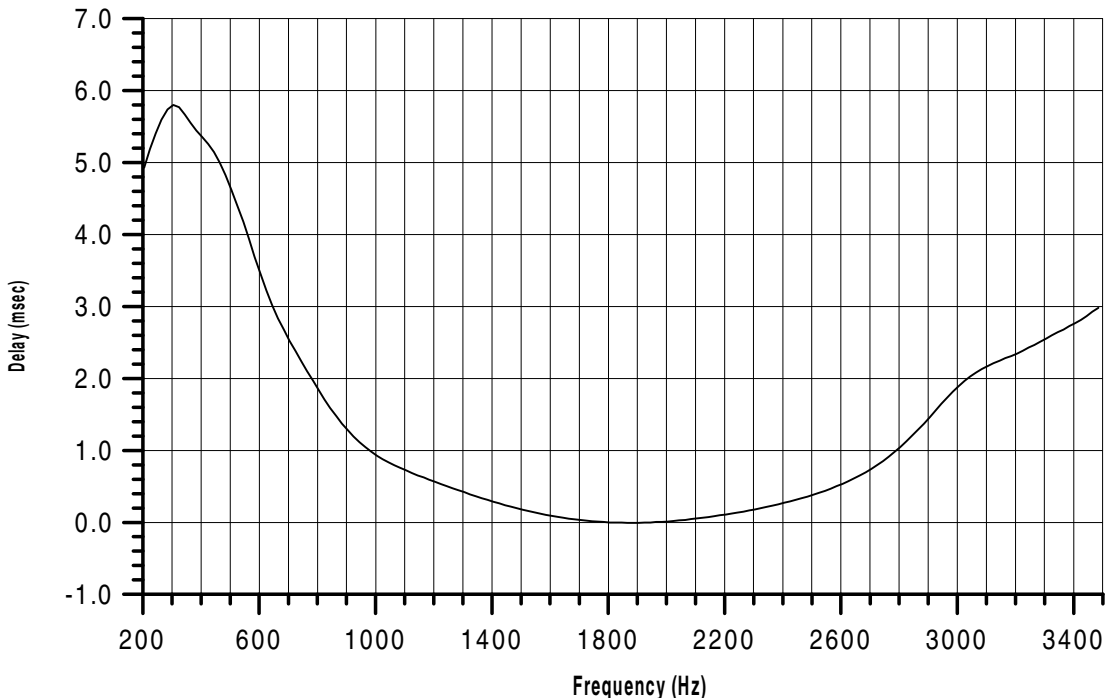

Figure 5-110. Ritt 1 Delay

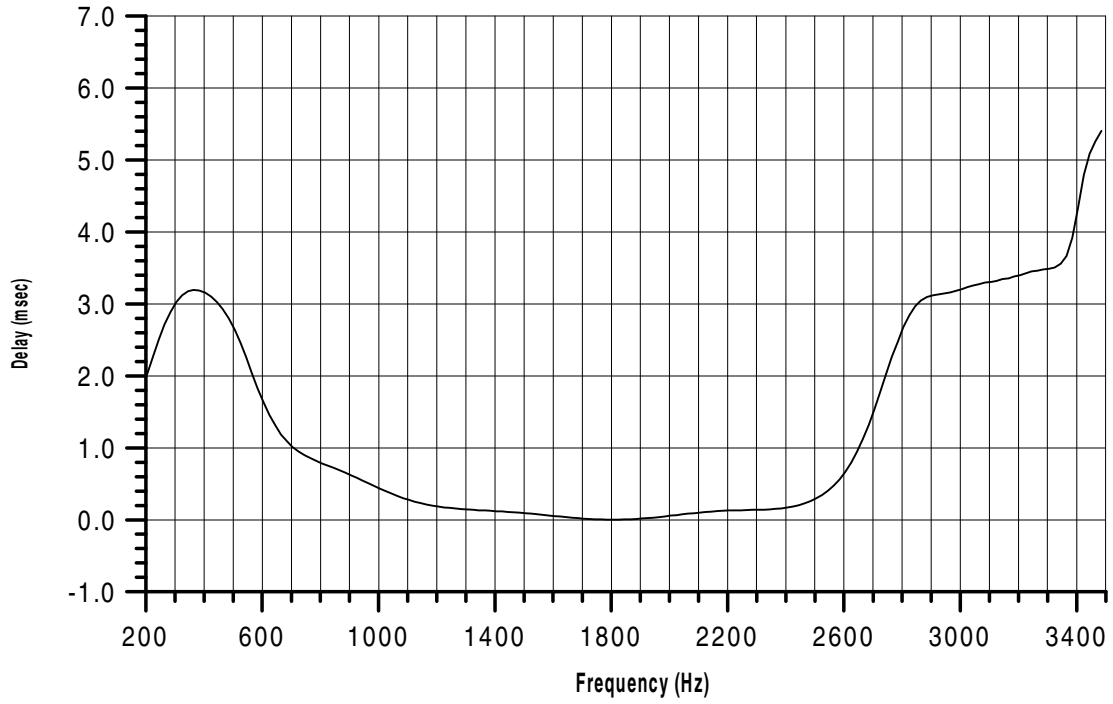

Figure 5-111. Ritt 2 Delay

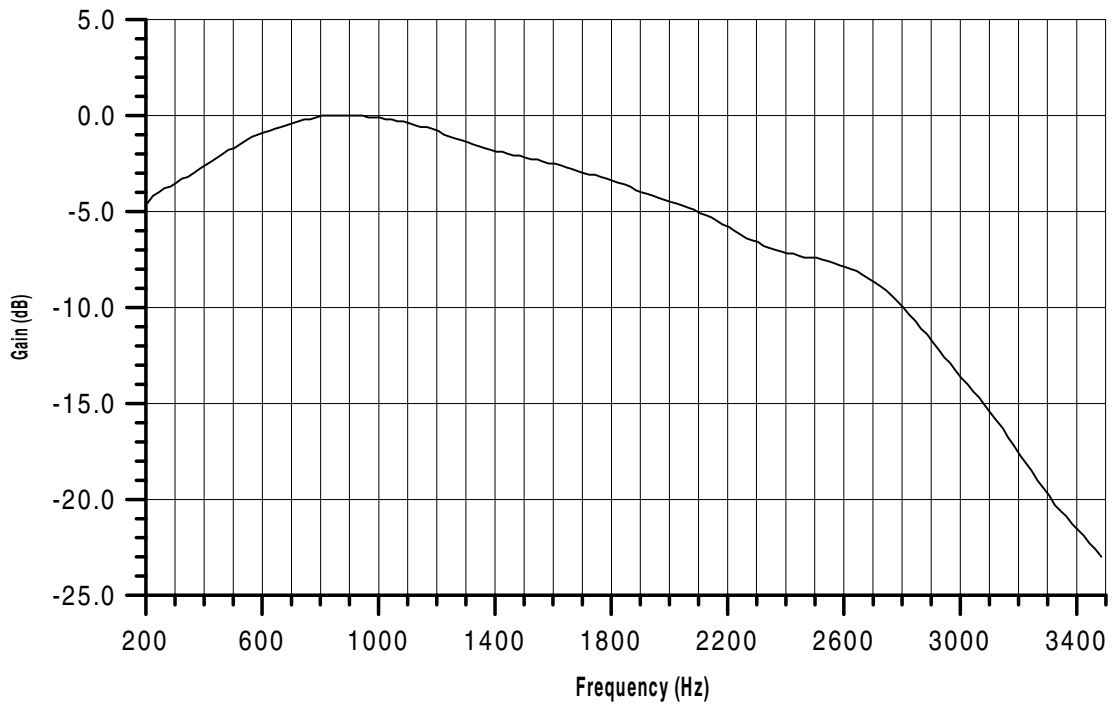

Figure 5-112. Ritt Gain

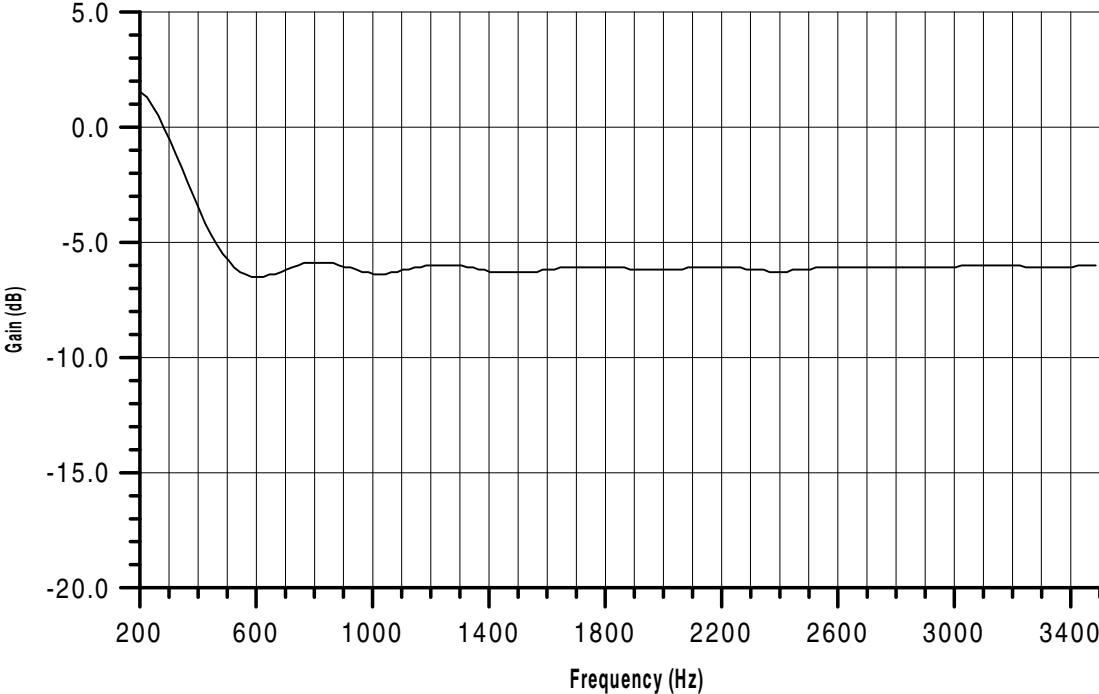

Figure 5-113. TAS Emulation of ATT 50150 Gain

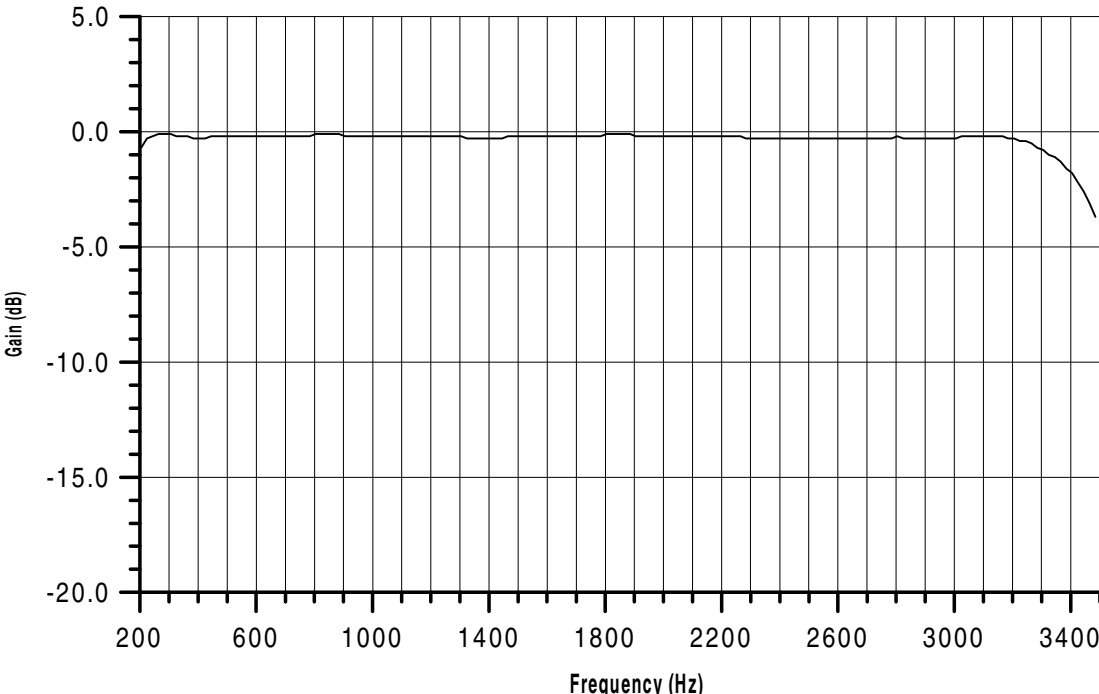

Figure 5-114. TAS Gain Response of 1 PCM/ECI ADPCM Link

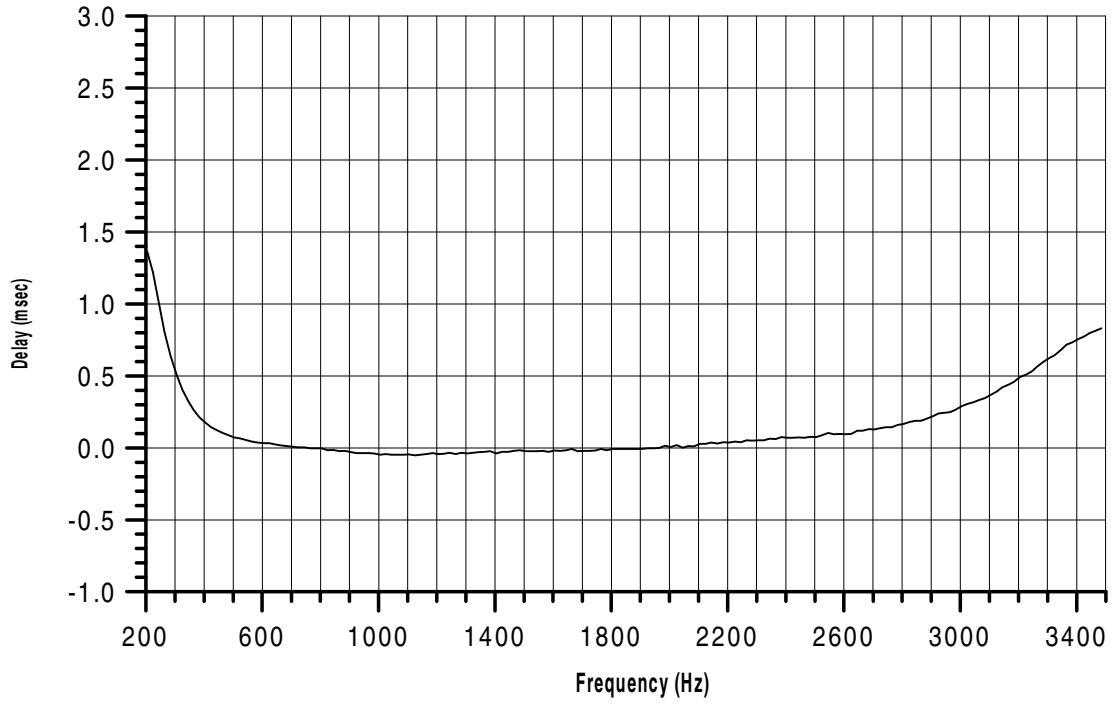

Figure 5-115. TAS Delay Response of 1 PCM/ECI ADPCM Link

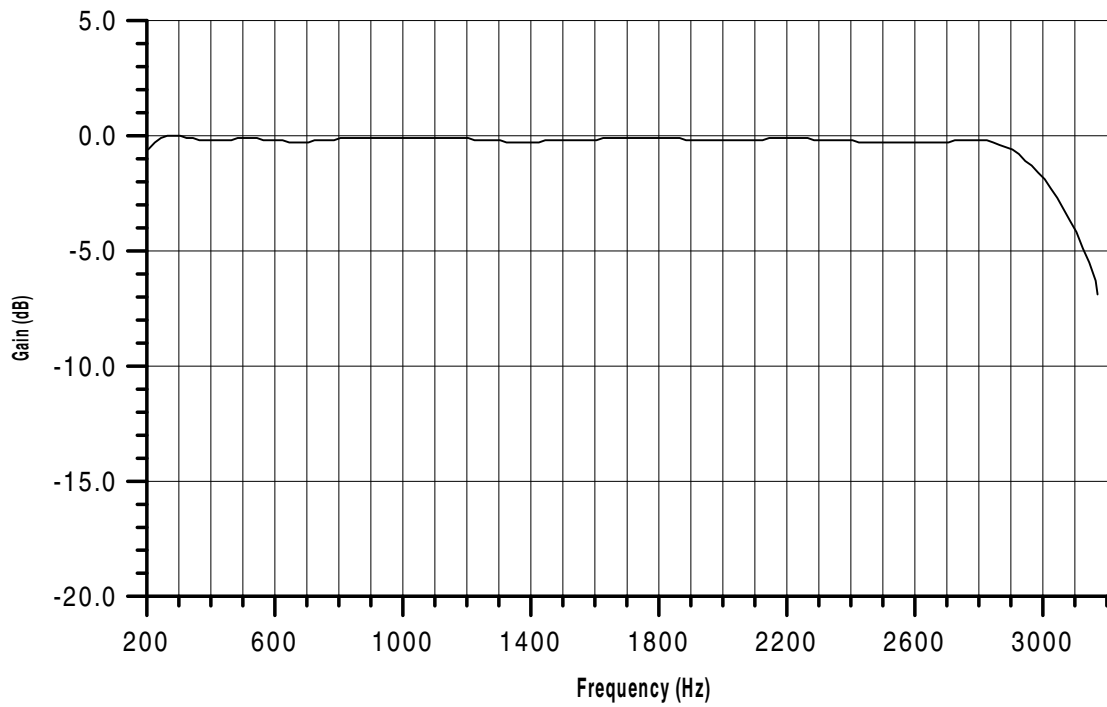

Figure 5-116. TAS Gain Response of 1 PCM/OKI ADPCM Link



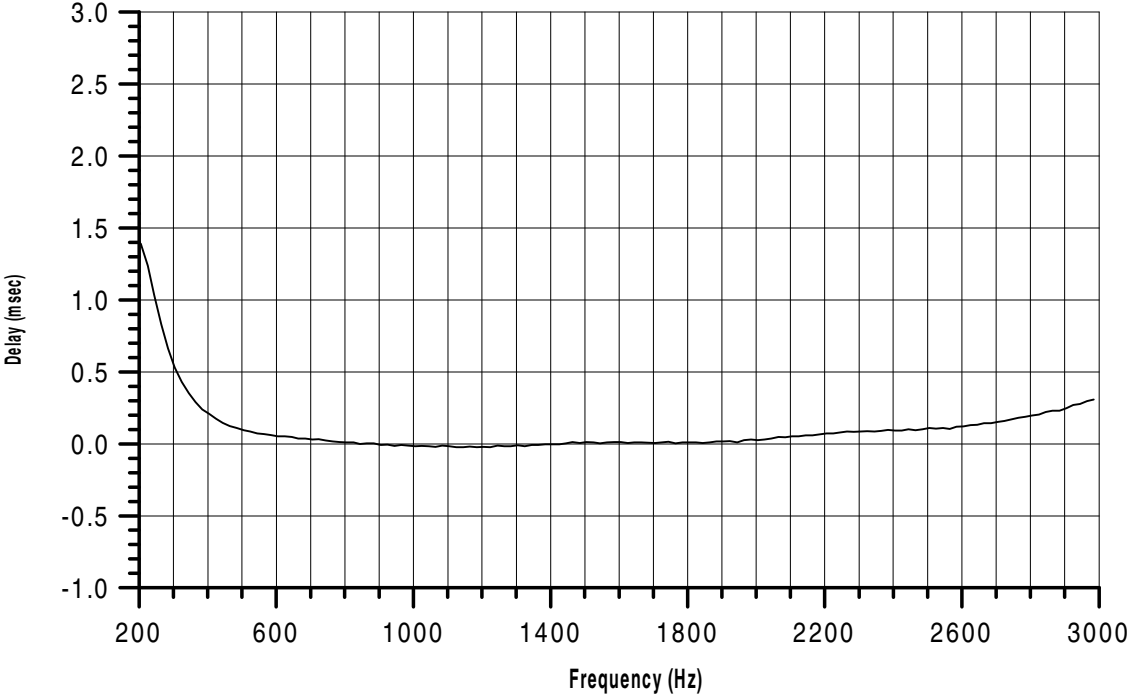

Figure 5-117. TAS Delay Response of 1 PCM/OKI ADPCM Link

This page intentionally left blank.