

ML12136
Rev. -

FIREBERD™ 6000

USER'S GUIDE

JANUARY 1992

COPY <u>10</u> OF _____
ASSIGNED TO: _____

©Telecommunications Techniques Corporation

TELECOMMUNICATIONS TECHNIQUES CORPORATION
20410 Observation Drive
Germantown, MD 20876 USA
Tel: (800) 638-2049 or (301) 353-1550 (MD) Fax: (301) 353-0731

PREFACE

The *FIREBERD 6000 User's Guide* is designed for all users of the FIREBERD 6000 Communications Analyzer. It serves to describe how the instrument is set up in a variety of applications and interfaces, including:

- RS-232-C/V.24 (built in)
- V.35 (Model 40202)
- RS-449/V.10, V.11 (Model 40200)
- RS-449/530/MIL (Model 41400)
- DDS Local Loop (Model 41131)
- DDS DS0A/B (Model 30678)
- DS1/T1/D4/ESF/SLC-96 (Model 40540)
- T1/FT1 (Model 41440)
- DS3 (Model 41945)
- CCITT G.703 64 kb/s (Model 30608)
- CCITT G.704 2048 kb/s (Model 30609)
- CCITT Fractional 2048 kb/s (Model 41800)

This document won't tell you everything about the FIREBERD 6000; the instrument's features and capabilities are fully described in the *FIREBERD 6000 Reference Manual*. But if you require quick access to step-by-step set-up procedures, you'll find the *FIREBERD 6000 User's Guide* a handy tool.

Welcome to the *FIREBERD 6000 User's Guide*. All of us at TTC hope it makes your job easier.



TABLE OF CONTENTS

SECTION	PAGE
1.0 FIREBERD 6000 SET-UPS	1-1
1.1 SECTION SUMMARY	1-1
1.2 RS-232-C/V.24 TESTING	1-1
1.3 V.35/306 DATA INTERFACE MODULE	1-5
1.4 RS-449 DATA INTERFACE MODULE	1-7
1.5 RS-449/530/MIL DATA INTERFACE MODULE	1-9
1.6 SYNCHRONOUS/ASYNCHRONOUS TEST RESULTS	1-14
1.7 NOTES ON SYNCHRONOUS AND ASYNCHRONOUS TESTING	1-16
1.8 DDS DS0A/B DATA INTERFACE MODULE	1-17
1.9 DDS LOCAL LOOP DATA INTERFACE MODULE	1-24
1.10 DDS DS0A/DS0B AND DDS LOCAL LOOP TEST RESULTS	1-29
1.11 NOTES ON DDS TESTING	1-31
1.12 T1/FT1 INTERFACE MODULE	1-32
1.13 DS1/T1/D4/ESF/SLC-96 INTERFACE MODULE	1-38
1.14 DS3 INTERFACE MODULE	1-45
1.15 T-CARRIER TEST RESULTS	1-50
1.16 NOTES ON T-CARRIER TESTING	1-51
1.17 2Mb/s/Nx64k INTERFACE MODULE	1-53
1.18 2Mbps/Nx64k TEST RESULTS	1-57
1.19 NOTES ON G.704 2048 kb/s TESTING	1-59
2.0 CONFIGURING THE FIREBERD 6000 FOR PRINTER OPERATION	2-1
2.1 SECTION SUMMARY	2-1
2.2 CONFIGURING THE FIREBERD WITH THE PR-40A PRINTER	2-1
2.3 CONFIGURING THE FIREBERD WITH THE PR-2000 PRINTER	2-3
APPENDIX A AUXILIARY FNCTIONS	A-1
APPENDIX B ANALYSIS RESULTS AND MESSAGES	B-1
APPENDIX C CHOOSING A TIMED OR CONTINUOUS TEST	C-1
APPENDIX D SAMPLE PRINT EVENTS SOFTKEY SEQUENCE BY INTERFACE	D-1
FIGURES	
1-1 RS-232 Menu Tree	1-2
1-2 RS-449/530/MIL Menu Tree (Type 118114)	1-10
1-3 RS-449/530/MIL Menu Tree (Type EIA-530)	1-10
1-4 RS-449/530/MIL Menu Tree (Type RS-449)	1-11

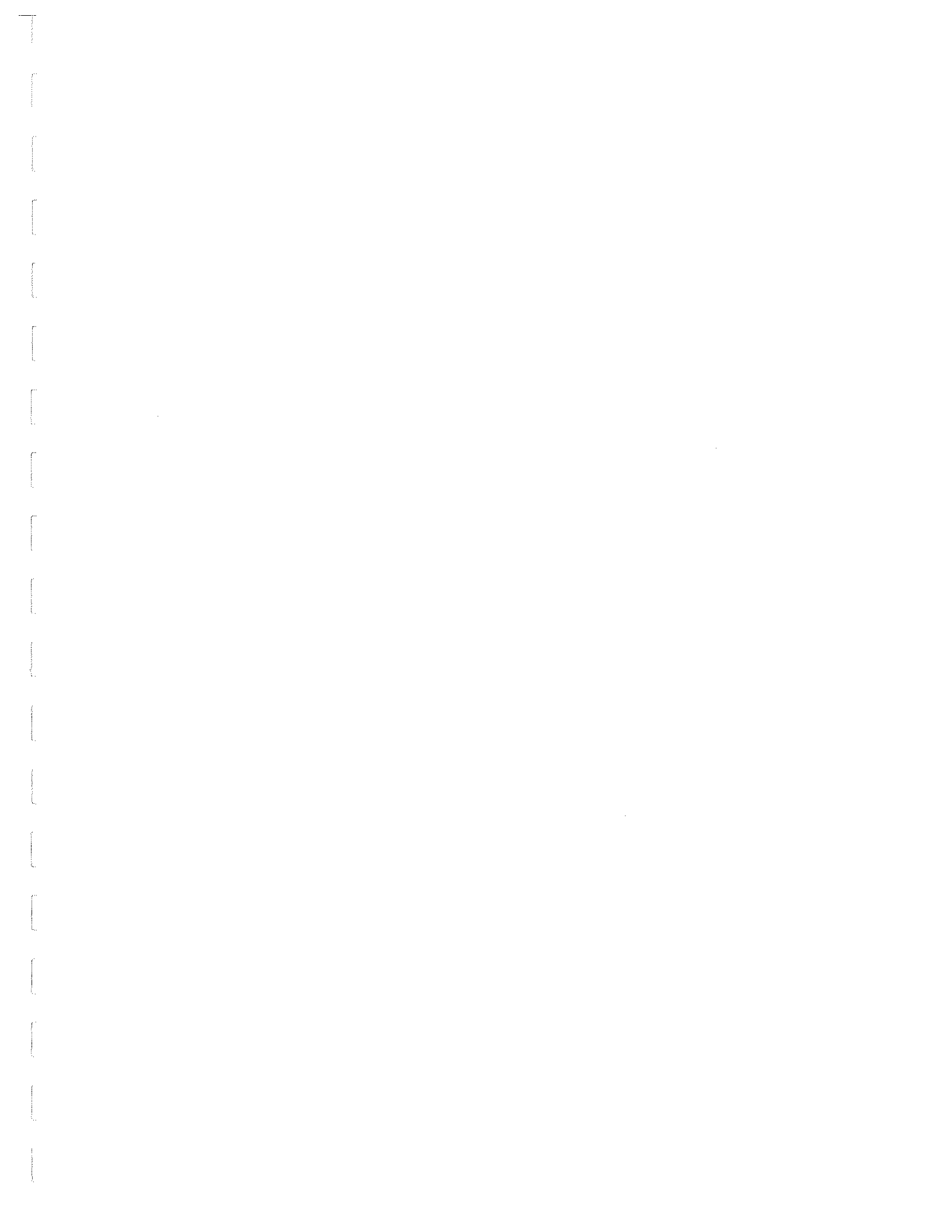


TABLE OF CONTENTS (Continued)

FIGURE	PAGE
1-5 RS-449/530/MIL Menu Tree (Type 188C)	1-11
1-6 DS0A/DS0B Menu Tree	1-18
1-7 Straightaway Test Configuration	1-22
1-8 DDS Local Loop Menu Tree	1-25
1-9 Network Loopback Test	1-25
1-10 Channel Loopback Test	1-28
1-11 T1/FT1 Menu Tree	1-33
1-12 End-To-End Fractional T1 Testing	1-33
1-13 Installing and Troubleshooting Customer Premise Equipment	1-35
1-14 DS1/T1/D4/ESF/SLC-96 Interface Module Menu Tree	1-38
1-15 Remote Loopback Test	1-39
1-16 End-to-End Testing of a Near-End and Far-End CSU	1-41
1-17 In-Service Monitoring	1-43
1-18 DS3 Interface Module Menu Tree	1-46
1-19 2Mbps-Nx64kbps Interface Module Menu Tree	1-54

TABLES

1-1 RS-232 Synchronous Test Set-Up	1-2
1-2 RS-232 Asynchronous Test Set-Up	1-3
1-3 V.35 Synchronous Test Set-Up	1-6
1-4 RS-449 Synchronous Test Set-Up	1-8
1-5 EIA-530 Synchronous Test Set-Up	1-12
1-6 MIL-STD-188C Asynchronous Test Set-Up	1-13
1-7 Synchronous Test Results	1-15
1-8 Asynchronous Test Results	1-15
1-9 Far-End OCU Loopback Test Set-Up	1-19
1-10 Far-End DSU Loopback Test Set-Up of Multipoint Circuits	1-20
1-11 Straightaway Test Set-Up	1-22
1-12 Network Loopback Test Set-Up (Primary Channel)	1-26
1-13 Channel Loopback Test Set-Up (Without Secondary Channel)	1-28
1-14 DDS DS0A/B Test Results	1-30
1-15 DDS Local Loop Test Results	1-30
1-16 End-To-End Fractional T1 Test Set-Up	1-34
1-17 CPE Test Set-Up (FIREBERD #1)	1-36
1-18 CPE Test Set-Up (FIREBERD #2)	1-36
1-19 T1 Loopback Test Set-Up	1-39
1-20 End-to-End T1 Test Set-Up	1-41
1-21 In-Service Monitoring Set-Up	1-43
1-22 DS3 In-Service Monitoring Set-Up Procedure	1-46
1-23 DS3 Far-End Loopback Test Set-Up	1-47

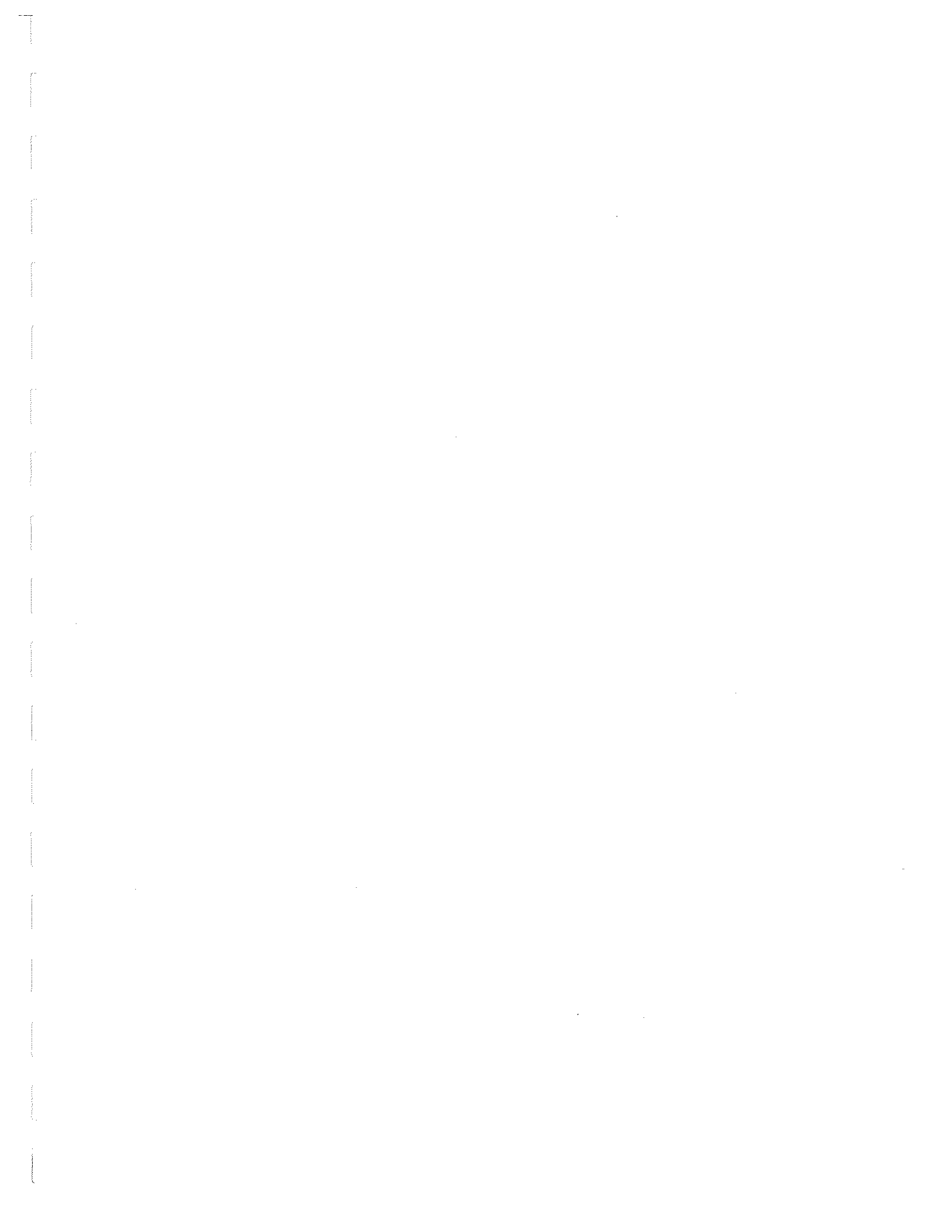
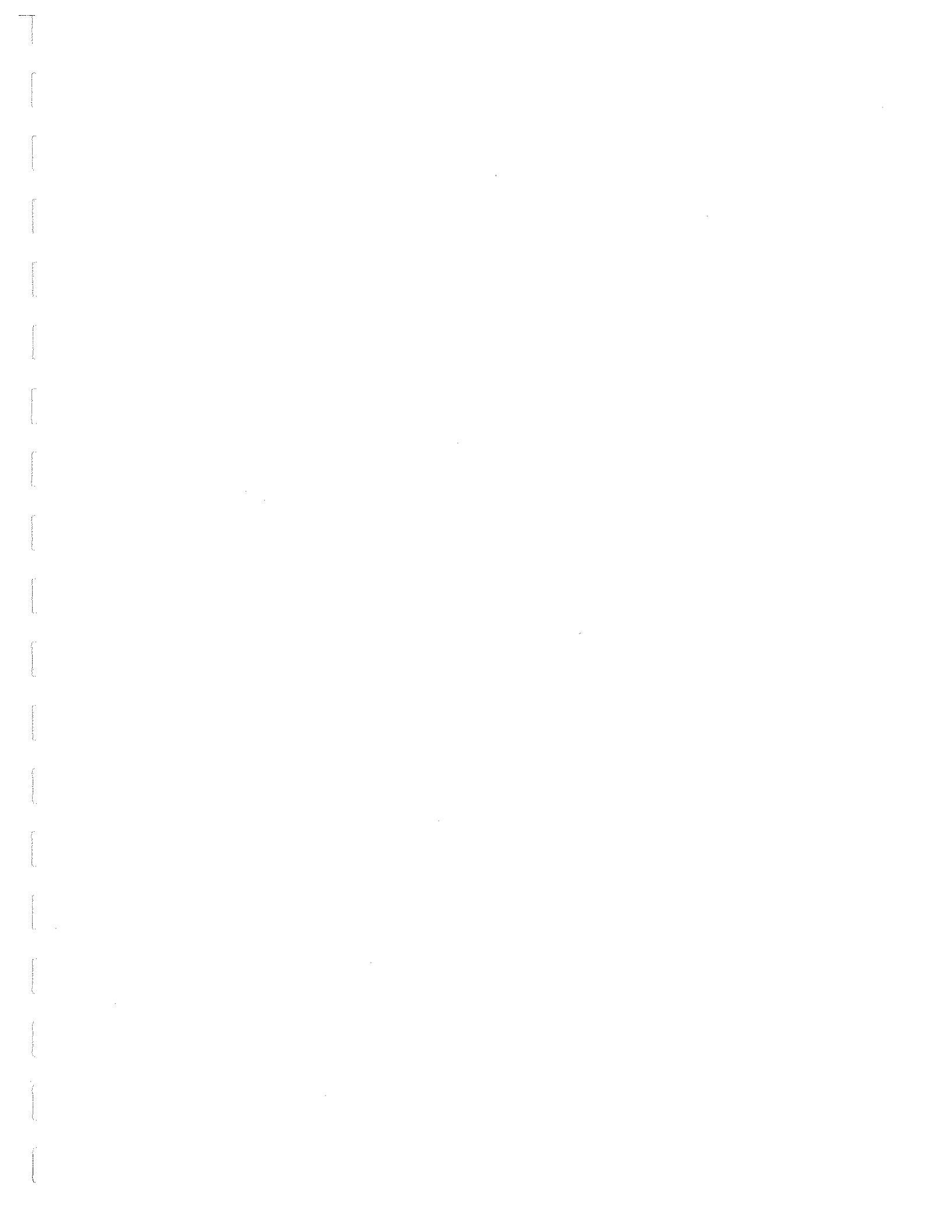
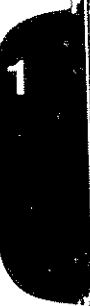


TABLE OF CONTENTS (Continued)

TABLE	PAGE
1-24 Point-To-Point Test Set-Up	1-49
1-25 DS1 Test Results	1-50
1-26 DS3 Test Results	1-51
1-27 2Mbps/Nx64 Out-of-Service Test Set-Up	1-54
1-28 2Mbps/Nx64 In-Service Test Set-Up	1-56
1-29 2Mbps/Nx64k Out-of-Service Test Results	1-57
1-30 2Mbps/Nx64k In-Service Test Results	1-58
2-1 Configuring the FIREBERD 6000 With The PR-40A Printer	2-1
2-2 Configuring the FIREBERD 6000 With The PR-2000 Printer	2-3
A-1 Status-Select Auxiliary Functions	A-1
A-2 Non-Status-Select Auxiliary Functions	A-3



SECTION 1 FIREBERD 6000 SET-UPS



1.1 SECTION SUMMARY

This section describes how the FIREBERD 6000 Communications Analyzer is set up in a variety of common test scenarios. Step-by-step instructions are provided for synchronous, asynchronous, DDS, DS0A/B, DS1/T1, and G.703 applications.

1.2 RS-232-C/V.24 TESTING

The RS-232-C/V.24 Data Interface is a built-in feature of the FIREBERD 6000. The interface meets EIA RS-232-C, CCITT V.24 and V.28, and ISO 2110-1980 standards.

PATTERNS:	All.
GEN CLK SOURCE:	SYNTH, INTF, and BNC.
DATA RATES:	Asynchronous — to 20 kb/s.
TIMING MODES:	Synchronous, asynchronous, and recovered.
FRONT PANEL CONTROL?	Yes.
CABLES/CONNECTORS:	RS-232 6' male-to-male and RS-232 10' male-to-male.

1.2.1 Basic RS-232 Synchronous Test Set-Up

Table 1-1 describes how the FIREBERD 6000 can be set up to perform an synchronous test using the instrument's built-in RS-232 Data Interface.



FIREBERD 6000 User's Guide

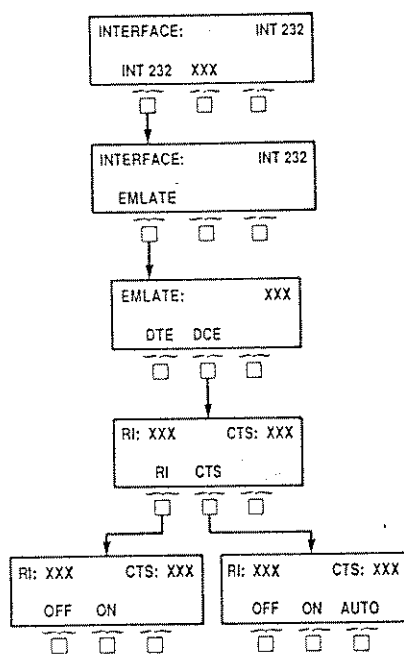


Figure 1-1
RS-232 Menu Tree

Table 1-1
RS-232 Synchronous Test Set-Up

Step	Activity
1.	Press the POWER switch to apply power to the FIREBERD 6000. NOTE: If the FIREBERD 6000 is in Self-Loop mode after power-up, disengage the SELF LOOP switch.
2.	Set the DATA switch to the 63, 511, or 2047 position, as appropriate for your test.
3.	Set the GEN CLK switch to the INTF position.
4.	Set the TIMING MODE switch to the SYNC position.
5.	Using the MENU switch: <ol style="list-style-type: none"> a. Configure the RS-232 Data Interface using INTF SETUP. Select these softkeys: <ol style="list-style-type: none"> 1. INT 232 to select the built-in RS-232 Data Interface.



Table 1-1
RS-232 Synchronous Test Set-Up (Continued)

Step	Activity
5. (cont.)	2. EMLATE to access the emulation menu. 3. DTE or DCE to select DTE or DCE emulation, as appropriate. b. Configure the FIREBERD for a TIMED or CONTINUOUS test using the TEST INTERVAL switch (see Appendix C). c. If hard-copy test results are desired, set the print event criteria using PRINT EVENT, then enable the printer control block (located to the left of the POWER switch) by setting the OFF/ON switch to the ON position. (See Appendix D for a sample print event set-up for a synchronous RS-232 test.)
6.	Illuminate the RTS and DTR switches located above the POWER switch to set both signaling leads HIGH.
7.	Using the appropriate cables, connect the FIREBERD 6000 to the equipment under test.
8.	Check that the SYNC LED (upper right corner of the unit) is illuminated.
	RESULT: The FIREBERD has achieved pattern synchronization and is gathering test results. (Section 1.6 lists all synchronous test results.)

1.2.2 Basic RS-232 Asynchronous Test Set-Up

Table 1-2 describes how the FIREBERD 6000 can be set up to perform an asynchronous test using an RS-232 Data Interface. Note that asynchronous testing can also be performed using the V.35 and RS-449 Data Interface Modules.

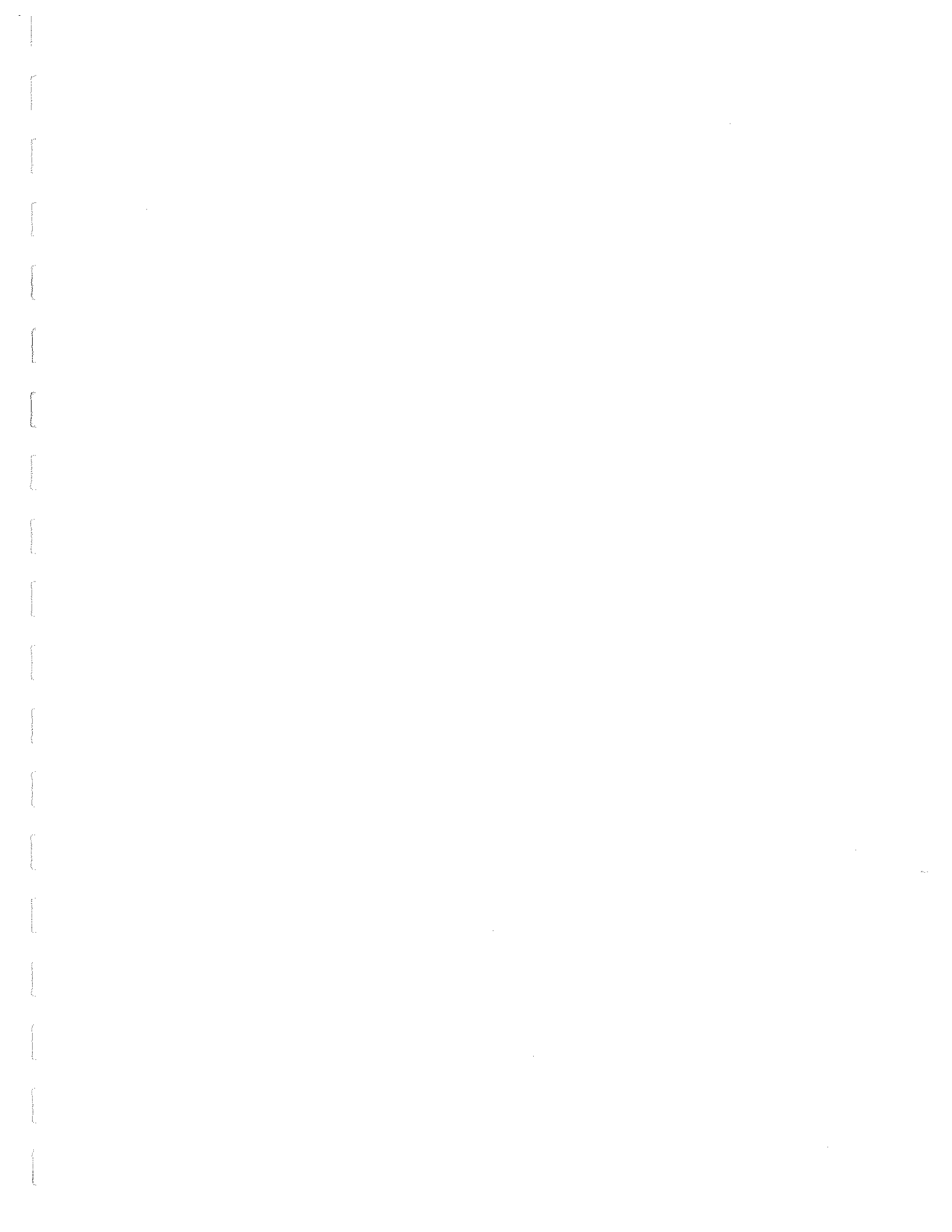
Table 1-2
RS-232 Asynchronous Test Set-Up

Step	Activity
1.	Press the POWER switch to apply power to the FIREBERD 6000. NOTE: If the FIREBERD 6000 is in Self-Loop mode after power-up disengage the SELF LOOP switch.
2.	Select a test data pattern using the DATA switch. NOTE: The recommended pattern for asynchronous testing is FOX.
3.	Set the GEN CLK switch to the SYNTH position.
4.	Set the TIMING MODE switch to the ASYNC position.

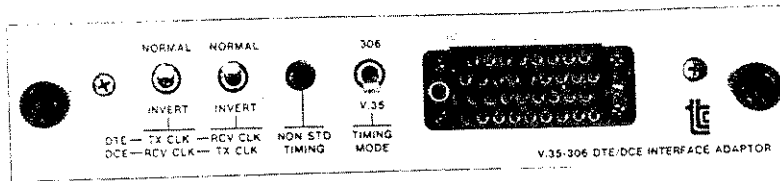


Table 1-2
RS-232 Asynchronous Test Set-Up (Continued)

Step	Activity
5.	<p>Using the MENU switch:</p> <ul style="list-style-type: none"> a. Set the synthesizer frequency to the desired baud rate using SYNTH FREQ and the appropriate softkey. Use the keypad to specify any baud rate not offered in the softkey menu. b. Configure the RS-232 Data Interface using INTF SETUP. Select these softkeys: <ul style="list-style-type: none"> 1. INT 232 to select the built-in RS-232 Data Interface. 2. EMLATE to access the emulation menu. 3. DTE or DCE to select DTE or DCE emulation, as appropriate. c. Select the desired asynchronous character format using CHAR FORMAT. <p>Sample Character Format Set-Up:</p> <ul style="list-style-type: none"> 1. DATA to access the data bit menu. 2. 7 to select seven data bit format. 3. PARITY to access the parity menu. 4. Δ EVEN to select EVEN parity. 5. STOP to access stop bit menu. 6. Δ 1 to select one stop bit. d. Configure the FIREBERD for a TIMED or CONTINUOUS test using the TEST INTERVAL switch (see Appendix C). e. If hard-copy test results are desired, set the print event criteria using PRINT EVENT, then enable the printer control block (located to the left of the POWER switch) by setting the OFF/ON switch to the ON position. (See Appendix D for a sample print event set-up for an RS-232 asynchronous test.)
6.	Illuminate the RTS and DTR switches located above the POWER switch to set both signaling leads HIGH.
7.	Using the appropriate cables, connect the FIREBERD 6000 to the equipment under test.
8.	Check that the SYNC LED (upper right corner of the unit) is illuminated.
<p>RESULT: The FIREBERD is gathering test results. (Section 1.6 lists all asynchronous test results.)</p>	
<p>Legend: Δ = Press the UP ARROW key MORE = Press the MORE key</p>	



1.3 V.35/306 DATA INTERFACE MODULE



The V.35/306 Data Interface Module meets CCITT V.35 Recommendations and Bell System Technical Reference PUB 41304 (306-type wideband data set) specifications. The module also meets PUB 41450 (DDS Data Service Unit) specifications.

- PATTERNS: All.
- GEN CLK SOURCE: SYNTH, BNC, and INTF.
- DATA RATES: Asynchronous: to 20 kb/s.
Synchronous: to 10 Mb/s.
Recovered: to 520 kb/s.
- TIMING MODES: Synchronous and asynchronous standard. Recovered timing is available with the Clock Recovery Option.
- FRONT PANEL CONTROL? No. Interface only.
- CABLES/CONNECTORS: V.35 34-pin male-to-male connectors (6' and 10').

Since the V.35 Data Interface Module is set up exclusively through its switches, no menu tree is shown.

1.3.1 Basic Synchronous Test Using the V.35 Data Interface Module

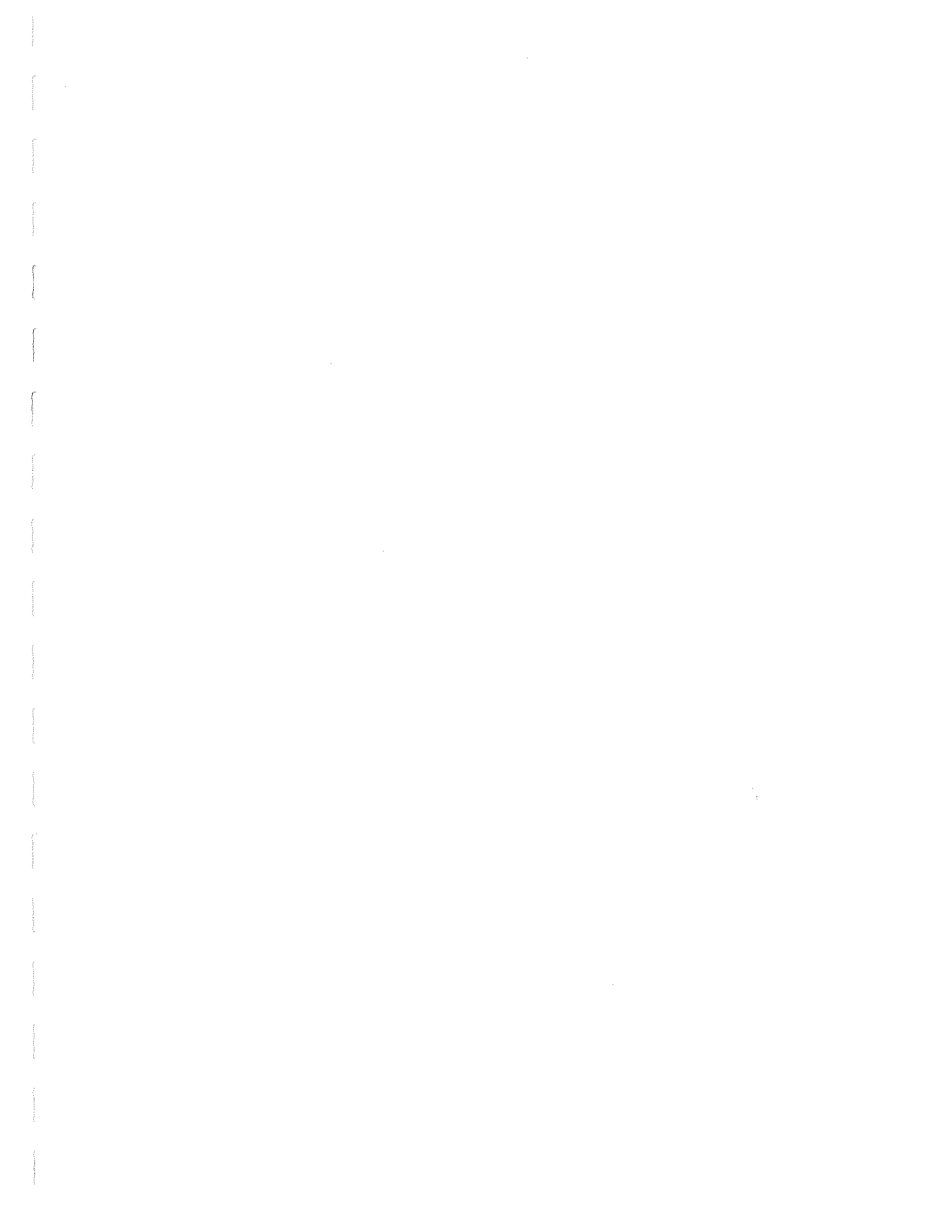
Table 1-3 describes how the FIREBERD 6000 can be set up to perform a basic synchronous test using the V.35 Data Interface Module.

IMPORTANT: If your test fails to run, Section 1.7 offers additional information about asynchronous testing.

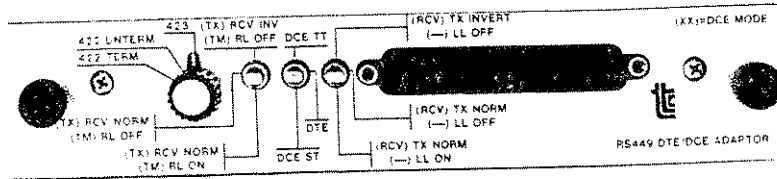


Table 1-3
V.35 Synchronous Test Set-Up

Step	Activity
1.	With the power to the FIREBERD turned off, insert the V.35 Data Interface Module in the designated rear-panel slot.
2.	Press the POWER switch to apply power to the FIREBERD 6000.
	NOTE: If the FIREBERD 6000 is in Self-Loop mode after power-up, disengage the SELF LOOP switch.
3.	Select a test data pattern using the DATA switch.
4.	Set the GEN CLK switch to the INTF position.
5.	Set the TIMING MODE switch to the SYNC position.
6.	Using the MENU switch:
	a. The V.35 Data Interface Module is not controllable via the FIREBERD's front panel. <i>Select</i> V.35 testing using INTF SETUP. <i>Configure</i> the V.35 Data Interface Module using the switches on the interface as follows:
	Standard Set-Ups:
	1. TRANSMIT CLOCK INVERT switch to NORMAL.
	2. RECEIVE CLOCK INVERT switch NORMAL.
	3. TIMING SWITCH switch to 306.
	b. Configure the FIREBERD for a TIMED or CONTINUOUS test using the TEST INTERVAL switch (see Appendix C).
	c. If hard-copy test results are desired, set the print event criteria using PRINT EVENT, then enable the printer control block (located to the left of the POWER switch) by setting the OFF/ON switch to the ON position. (See Appendix D for a sample print event set-up for a V.35 synchronous test.)
7.	Illuminate the RTS and DTR switches located above the POWER switch to set both signaling leads HIGH.
8.	Using the appropriate cables, connect the FIREBERD 6000 to the equipment under test.
9.	Check that the SYNC LED (upper right corner of the unit) is illuminated.
	RESULT: The FIREBERD has achieved pattern synchronization and is gathering test results. (Section 1.6 lists all synchronous test results.)



1.4 RS-449 DATA INTERFACE MODULE



The RS-449 Data Interface Module meets RS-449 standards and CCITT V.10/V.11 Recommendations. The interface offers three modes of operation: RS-423 (unbalanced), RS-422 (balanced) terminated, and RS-422 (balanced) unterminated.

PATTERNS:	All.
GEN CLK SOURCE:	SYNTH, INTF, and BNC.
DATA RATES:	Asynchronous: to 20 kb/s. Synchronous: to 130 kb/s for RS-423/V.10 drivers/receivers to 520 kb/s for RS-422/V.11.
TIMING MODES:	Synchronous and asynchronous standard. Recovered timing is available with the Clock Recovery Option.
FRONT PANEL CONTROL?	No. Interface only.
CABLES/CONNECTORS:	RS-449 37-pin D male-to-male connectors (6' and 10'). RS-449 DTE 37-pin D to X.21 DTE 15-pin D (6').

Since the RS-449 Data Interface Module is set up exclusively through its switches, no menu tree is shown.

1.4.1 Basic Synchronous Test Using the RS-449 Data Interface Module

Table 1-4 describes how the FIREBERD 6000 can be set up to perform a basic synchronous test using the RS-449 Data Interface.

IMPORTANT: If your test fails to run, Section 1.7 offers additional information about synchronous testing.

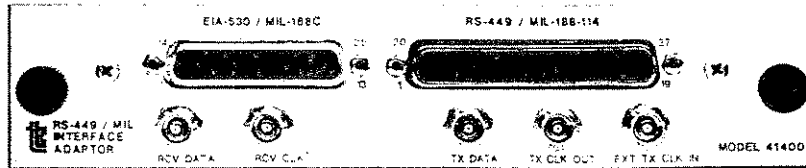
1
2
3
4
5
6
7
8
9
10
11
12
13
14
15
16
17
18
19
20
21
22
23
24
25
26
27
28
29
30
31
32
33
34
35
36
37
38
39
40
41
42
43
44
45
46
47
48
49
50
51
52
53
54
55
56
57
58
59
60
61
62
63
64
65
66
67
68
69
70
71
72
73
74
75
76
77
78
79
80
81
82
83
84
85
86
87
88
89
90
91
92
93
94
95
96
97
98
99
100

Table 1-4
RS-449 Synchronous Test Set-Up

Step	Activity
1.	With the power to the FIREBERD turned off, insert the RS-449 Data Interface Module in the designated rear-panel slot.
2.	Press the POWER switch to apply power to the FIREBERD 6000.
	NOTE: If the FIREBERD 6000 is in Self-Loop mode after power-up, disengage the SELF LOOP switch.
3.	Select a test data pattern using the DATA switch.
4.	Set the GEN CLK switch to the INTF position.
5.	Set the TIMING MODE switch to the SYNC position.
6.	Using the MENU switch:
	a. The RS-449 Data Interface Module is not controllable via the FIREBERD's front panel. <i>Select</i> RS-449 testing using INTF SETUP. <i>Configure</i> the RS-449 Data Interface Module using the switches on the interface as follows:
	Standard Set-Ups:
	1. 422 TERM/422 UNTERM/423 switch to 422 TERM.
	2. TRANSMIT CLOCK INVERT switch to RCV NORM/RL OFF.
	3. DCE TT/DTE/DCE ST switch to DTE.
	4. RECEIVE CLOCK INVERT switch to TX NORM/LL OFF.
	b. Configure the FIREBERD for a TIMED or CONTINUOUS test using the TEST INTERVAL switch (see Appendix C).
	c. If hard-copy test results are desired, set the print event criteria using PRINT EVENT, then enable the printer control block (located to the left of the POWER switch) by setting the OFF/ON switch to the ON position. (See Appendix D for a sample print event set-up for an RS-449 synchronous test.)
7.	Illuminate the RTS and DTR switches located above the POWER switch to set both signaling leads HIGH.
8.	Using the appropriate cables, connect the FIREBERD 6000 to the equipment under test.
9.	Check that the SYNC LED (upper right corner of the unit) is illuminated.
	RESULT: The FIREBERD has achieved pattern synchronization and is gathering test results. (Section 1.6 lists all synchronous test results.)



1.5 RS-449/530/MIL DATA INTERFACE MODULE



The RS-449/530/MIL Data Interface Module meets CCITT Recommendations for V.10 and V.11, EIA RS-422-A, EIA RS-423-A, EIA RS-449, EIA RS-530, ISO 4902, MIL-STD-188-114, MIL-STD-188-100, and MIL-STD-188C. It enables the testing and analysis of RS-449, MIL-188-114, EIA-530, and MIL-188C circuits and equipment. A 25-pin, D-type connector is used for testing EIA-530 and MIL-188C; a 37-pin, D-type connector is used for testing RS-449 and MIL-188-114.

PATTERNS:	All
GEN CLK SOURCE:	SYNTH, INTF, and BNC
DATA RATES:	<p>MIL-188C:</p> <p>Synchronous: to 64 kb/s</p> <p>Asynchronous: to 20 kb/s</p> <p>Recovered: to 64 kb/s</p> <p>EIA-530, MIL-188-114, RS-449 Balanced:</p> <p>Synchronous: to 15 Mb/s</p> <p>Asynchronous: to 20 kb/s</p> <p>Recovered: to 520 kb/s</p> <p>EIA-530, MIL-188-114, RS-449 Unbalanced:</p> <p>Synchronous: to 128 kb/s</p> <p>Asynchronous: to 20 kb/s</p> <p>Recovered: to 128 kb/s</p>
TIMING MODES:	Synchronous, asynchronous, and recovered. (Clock Recovery Option required for recovered timing.)
FRONT PANEL CONTROL?	Yes
CABLES/CONNECTORS:	<p>RS-449 DTE 37-pin D to X.21 DTE 15-pin D (6')</p> <p>RS-232/EIA-530/V.24 male-to-male connector (10')</p> <p>RS-449/530/MIL-188 37-pin D-type male-to-male (10')</p> <p>MIL-188 37-pin D-type male to 25-pin D-type male (6')</p> <p>MIL-188 37-pin D-type male to 25-pin D-type female (6')</p>



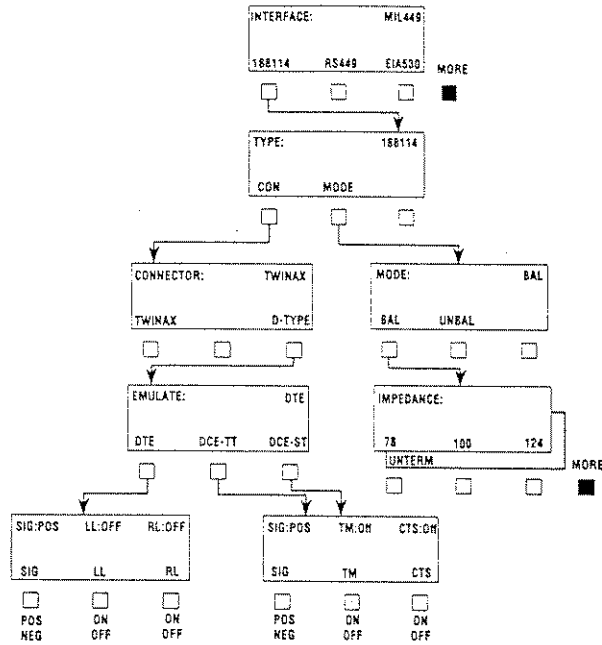


Figure 1-2
RS-449/530/MIL Menu Tree (Type 118114)

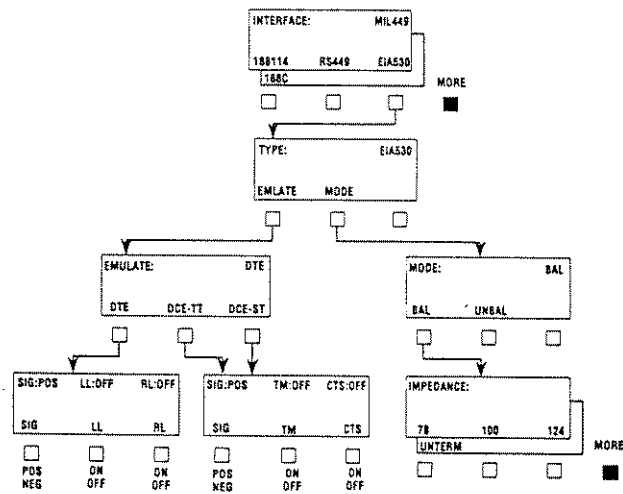
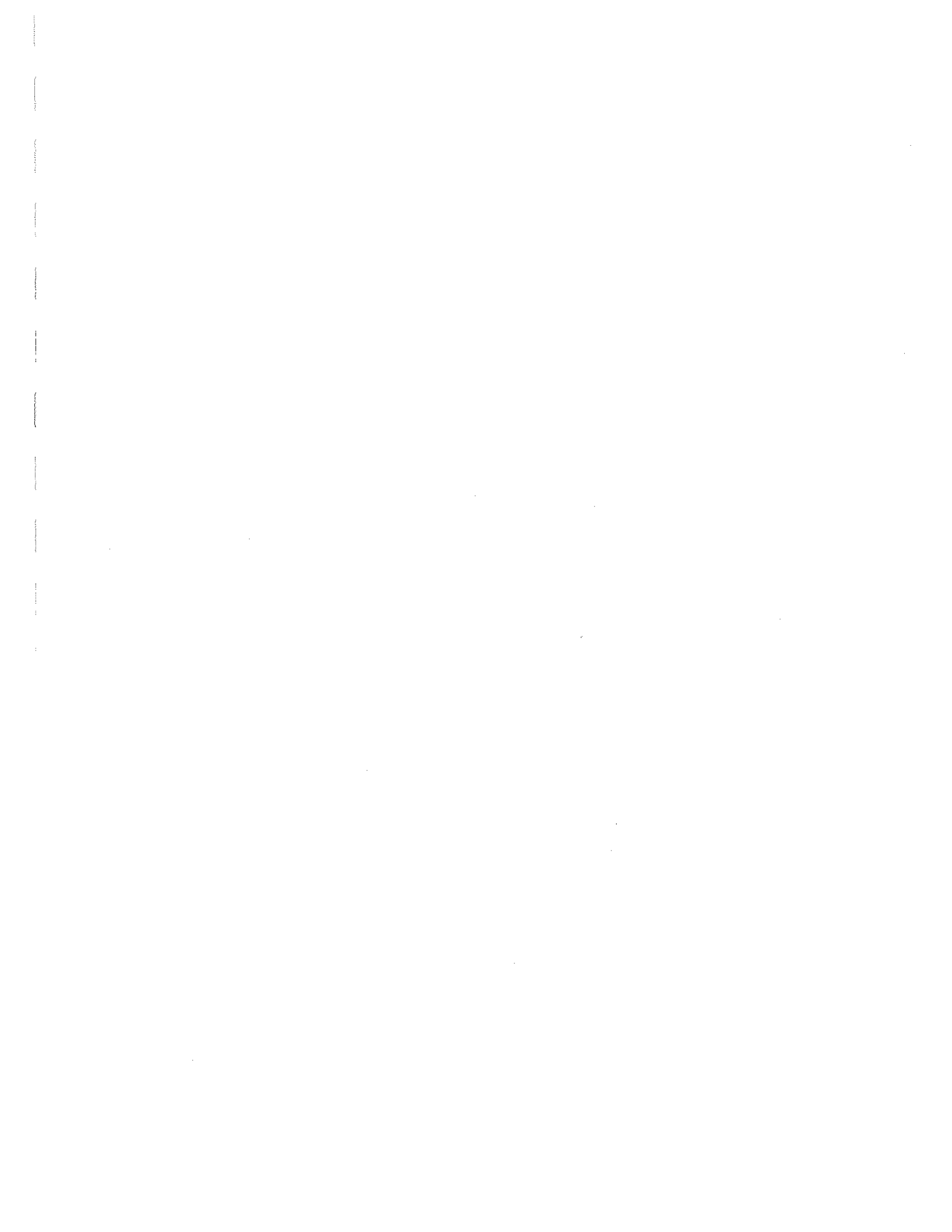


Figure 1-3
RS-449/530/MIL Menu Tree (Type EIA-530)



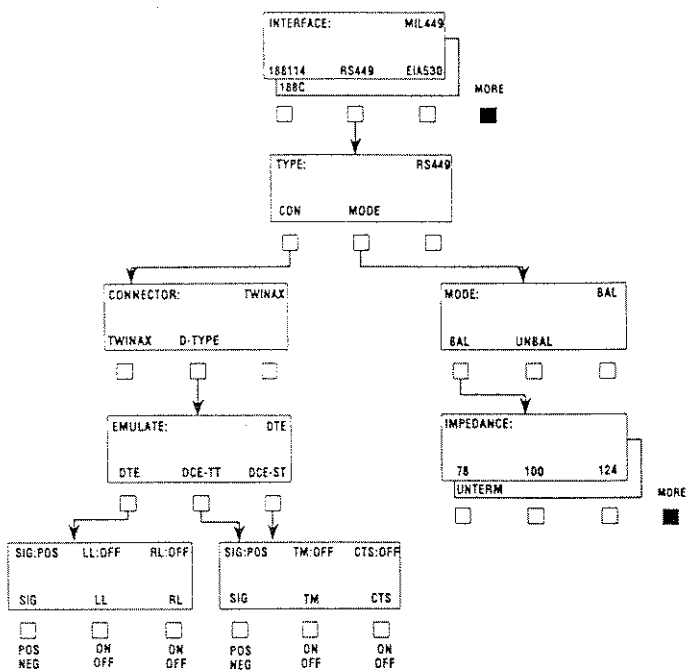


Figure 1-4
RS-449/530/MIL Menu Tree (Type RS-449)

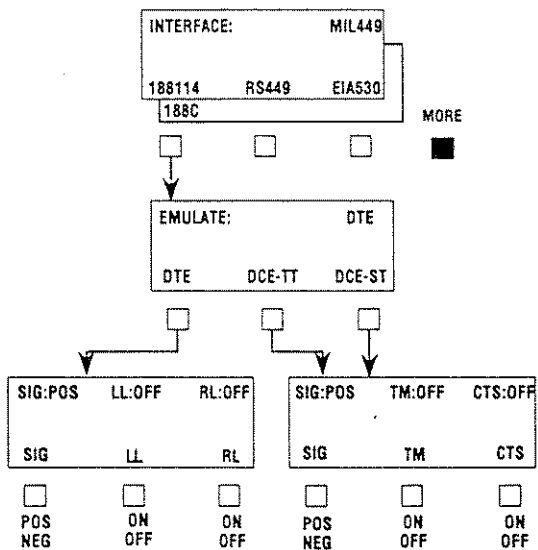


Figure 1-5
RS-449/530/MIL Menu Tree (Type 188C)

1
2
3
4
5
6
7
8
9
10
11
12
13
14
15
16
17
18
19
20
21
22
23
24
25
26
27
28
29
30
31
32
33
34
35
36
37
38
39
40
41
42
43
44
45
46
47
48
49
50
51
52
53
54
55
56
57
58
59
60
61
62
63
64
65
66
67
68
69
70
71
72
73
74
75
76
77
78
79
80
81
82
83
84
85
86
87
88
89
90
91
92
93
94
95
96
97
98
99
100

1.5.1 EIA-530 Synchronous Test Set-Up

Table 1-5 describes how the FIREBERD 6000 can be set up to perform a basic synchronous test using the RS-449/530/MIL Data Interface Module.

IMPORTANT: If your test fails to run, Section 1.7 offers additional information about synchronous testing.

Table 1-5
EIA-530 Synchronous Test Set-Up

Step	Activity
1.	With the power to the FIREBERD turned off, insert the RS-449/530/MIL Data Interface Module in the designated rear-panel slot.
2.	Press the POWER switch to apply power to the FIREBERD 6000. NOTE: If the FIREBERD 6000 is in Self-Loop mode after power-up, disengage the SELF LOOP switch.
3.	Set the DATA switch to the 511 or 2047 position when transmitting data to a near-end or far-end modem, or the 2047 or 2 ¹⁵ -1 position when testing a 64 kb/s substrate channel.
4.	Set the GEN CLK switch to the INTF position.
5.	Set the TIMING MODE switch to the SYNC position.
6.	Using the MENU switch: a. Configure the RS-449/530/MIL Data Interface Module using INTF SETUP. Select these softkeys: Standard Set-Ups: 1. MIL449 to select the RS-449/530/MIL Data Interface Module. 2. EIA530 to select the interface-type. 3. EMULATE to select DTE or DCE emulation, as appropriate. 4. SIGNALING to POSITIVE. 5. LL (Local Loop) and RL (Remote Loopback) ON or OFF based on test requirements. 6. Δ MODE to select the mode menu. 7. BAL for balanced mode. 8. IMPEDANCE as required (78, 100, 124, or UNTERM). b. Configure the FIREBERD for a TIMED or CONTINUOUS test using the TEST INTERVAL switch (see Appendix C). c. If hard-copy test results are desired, set the print event criteria using PRINT EVENT, then enable the printer control block (located to the left of the POWER switch) by setting the OFF/ON switch to the ON position.
Legend: Δ = Press the UP ARROW key MORE = Press the MORE key	



Table 1-5
EIA-530 Synchronous Test Set-Up (Continued)

Step	Activity
7.	Illuminate the RTS and DTR switches located above the POWER switch to set both signaling leads HIGH.
8.	Using the appropriate cables, connect the FIREBERD 6000 to the equipment under test.
9.	Check that the SYNC LED (upper right corner of the unit) is illuminated.
	RESULT: The FIREBERD has achieved pattern synchronization and is gathering test results. (Section 1.6 lists all synchronous test results.)

1.5.2 MIL-STD-188C Asynchronous Test Set-Up (DTE Emulation)

Table 1-6 describes how the FIREBERD 6000 can be set up to perform an asynchronous test of MIL-STD-188C circuits and equipment using the RS-449/530/MIL Data Interface Module. These procedures assume DTE emulation.

IMPORTANT: If your test fails to run, Section 1.7 offers additional information about asynchronous testing.

Table 1-6
MIL-STD-188C Asynchronous Test Set-Up

Step	Activity
1.	With the power to the FIREBERD turned off, insert the RS-449/530/MIL Data Interface Module in the designated rear-panel slot.
2.	Press the POWER switch to apply power to the FIREBERD 6000. NOTE: If the FIREBERD 6000 is in Self-Loop mode after power-up, the SELF LOOP switch.
3.	Set the DATA switch to the FOX position. NOTE: This pattern is recommended rather than required.
4.	Set the GEN CLK switch to the SYNTH position.
5.	Set the TIMING MODE switch to the ASYNC position.
6.	Set the MENU switch to the SYNTH FREQ position. Set the synthesizer frequency to the desired rate.

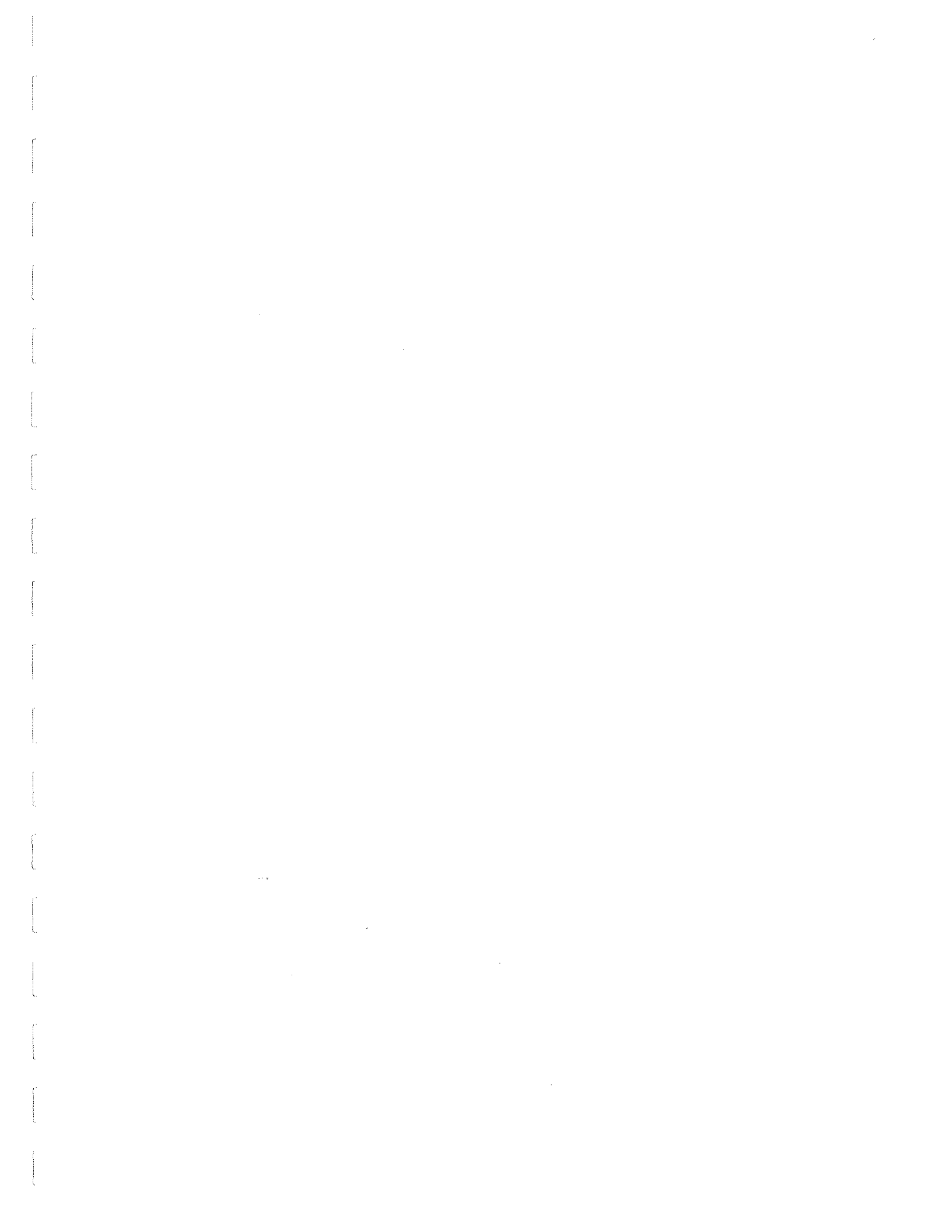


Table 1-6
MIL-STD-188C Asynchronous Test Set-Up (Continued)

Step	Activity
7.	<p>Using the MENU switch:</p> <p>a. Configure the RS-449/530/MIL Data Interface Module using INTF SETUP. Select these softkeys:</p> <p>Standard Set-Ups:</p> <ol style="list-style-type: none"> 1. MIL449 to select the RS-449/530/MIL Data Interface Module. 2. MORE 188C to select the MIL-188C interface-type. 3. DTE, DCE-TT, or DCE-ST emulation, as appropriate. 4. SIGNALing to POSitive. 5. LL (Local Loop) and RL (Remote Loopback) ON or OFF based on test requirements. 6. Δ MODE to select the MODE menu. 7. BAL for balanced mode. 8. IMPEDANCE as required (78, 100, 124, or UNTERM). <p>b. Set data, parity, and stop bits using CHAR FORMAT.</p> <p>c. Configure the FIREBERD for a TIMED or CONTINUOUS test using the TEST INTERVAL switch (see Appendix C).</p> <p>d. If hard-copy test results are desired, set the print event criteria using PRINT EVENT, then enable the printer control block (located to the left of the POWER switch) by setting the OFF/ON switch to the ON position.</p> <p>8. Using the appropriate cables, connect the FIREBERD 6000 to the equipment under test.</p> <p>9. Illuminate the RTS and DTR switches located above the POWER switch to set both signaling leads HIGH.</p> <p>10. If performing a loopback test, establish a loop by performing the procedures which are appropriate for your DCE.</p> <p>11. Check that the SYNC LED (upper right corner of the unit) is illuminated.</p> <p>RESULT: The FIREBERD has achieved pattern synchronization and is gathering test results. (Section 1.6 lists all synchronous test results.)</p>
<p>Legend: Δ = Press the UP ARROW key MORE = Press the MORE key</p>	

1.6 SYNCHRONOUS/ASYNCHRONOUS TEST RESULTS

Tables 1-7 and 1-8 list the synchronous and asynchronous test results that are available when using the RS-232, V.35, RS-449, and RS-449/MIL Data Interface Modules. These results can be collected via printer or can be viewed at the ANALYSIS display windows.

Appendix B offers a glossary of all test results offered by the FIREBERD 6000.

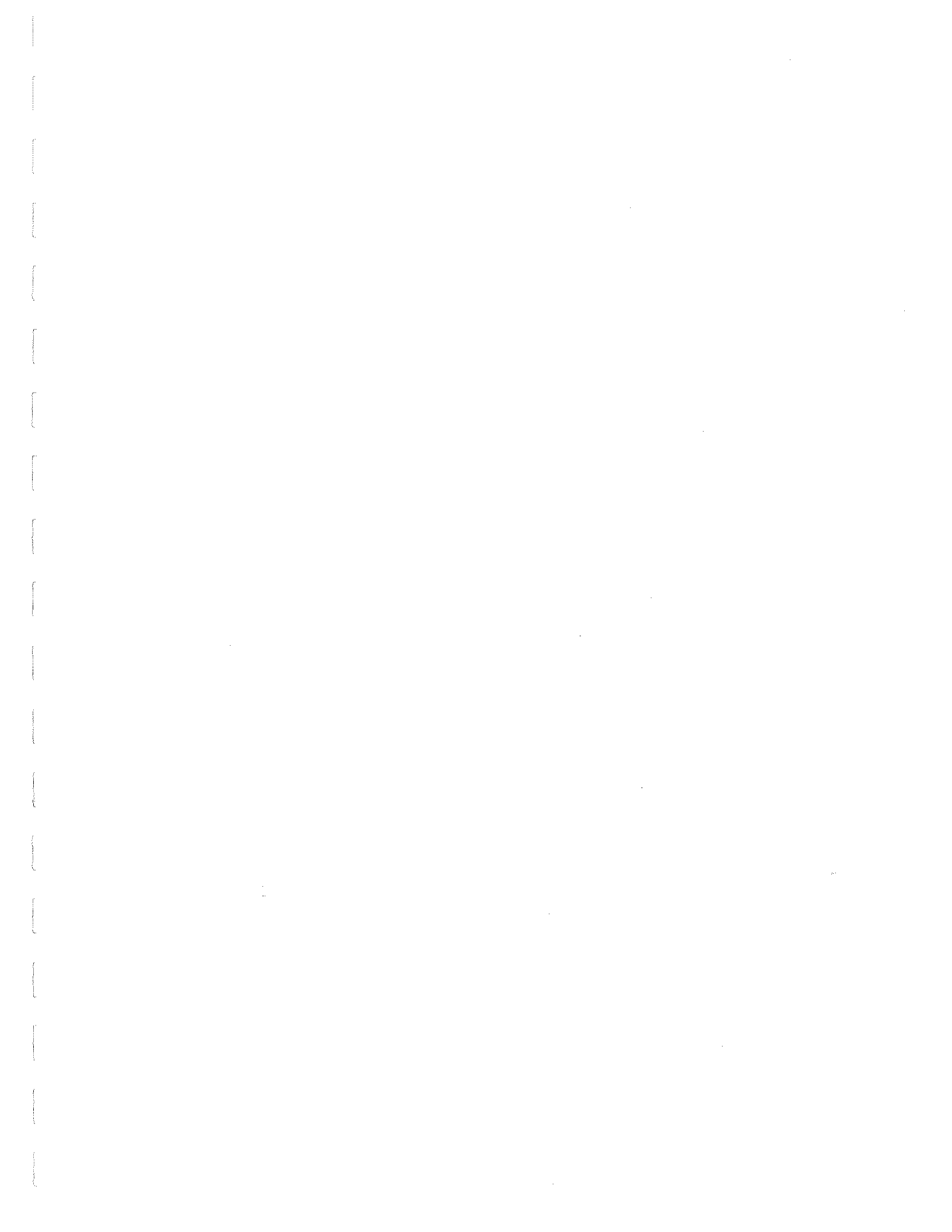


Table 1-7
Synchronous Test Results

Category	Switch			
ERROR	BER PAT SLIP	BLOCKS BIT ERRS	BLK ERRS AVG BER	AVG BLER
PERFORMANCE	DEG MIN UNA SEC BER-SES	%DEG MIN AVL SEC GERR SEC	SES %AVL SEC G EFS	%SES ERR-SES G %EFS
TIME	ERR EAS %PAT SEC	EA SEC ELAP SEC	E F EAS TIME	PATL SEC DATE
SIGNAL	DELAY	GEN FREQ	RCV FREQ	
T-CARRIER	Not applicable.			
ALARM	PAT LOSS PWR LOSS	DAT LOSS	CLK LOSS	C-D CHA

Table 1-8
Asynchronous Test Results

Category	Results			
ERROR	BIT ERRS BLK ERRS	AVG BER AVG BLER	BER CHAR ERR	BLOCKS
PERFORMANCE	DEG MIN UNA SEC BER-SES	%DEG MIN AVL SEC GERR SEC	SES %AVL SEC G EFS	%SES ERR-SES G %EFS
TIME	ERR EAS %PAT SEC	E A SEC ELAP SEC	E F EAS TIME	PATL SEC DATE
SIGNAL	DELAY	GEN FREQ		
T-CARRIER	Not applicable.			
ALARM	PAT LOSS	DAT LOSS	PWR LOSS	



1.7 NOTES ON SYNCHRONOUS AND ASYNCHRONOUS TESTING

If your test fails to run after completing the set-up procedures for your synchronous or asynchronous test, the sections that follow may lead you to the solution. Note that only the most likely potential problem areas are addressed; if your test still fails to run after exploring these problem areas, call TTC's toll-free number (1-800-638-2049) for technical assistance.

1.7.1 Flow Control

Data pattern transmission can be inhibited when the out-of-band flow control setting on the FIREBERD 6000 conflicts with the requirements of your specific application.

Out-of-band flow control is specified using Auxiliary Function 08. If your test does not require the implementation of out-of-band flow control, make sure Auxiliary Function 08 is turned OFF. If your test requires out-of-band flow control, turn Auxiliary Function 08 ON and identify the signals that enable data transmission.

1.7.2 Non-Availability of the Selected Timing Source

If the GEN CLK switch is illuminated when set to the INTF position, it means that the selected timing source is not available. Check your cables to ensure that they are properly connected. If, after checking your cables, the switch is still illuminated, do the following:

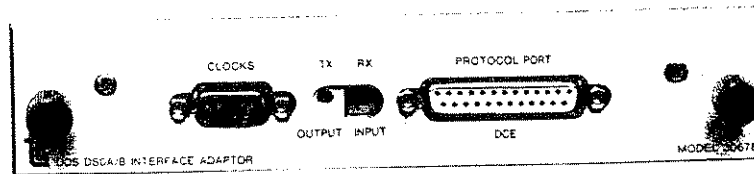
1. Reset the GEN CLK switch to the SYNTH position.
2. Using the MENU switch, set the synthesizer frequency to the desired rate using SYNTH FREQ and the appropriate softkey.

1.7.3 Setting Auxiliary Functions

Sometimes the setting of one of the auxiliary functions may not be appropriate for your specific test. Use Auxiliary Function 99 to reset all of your auxiliary functions to their default states.

CAUTION: THE USE OF THIS FUNCTION RESETS ALL AUXILIARY FUNCTIONS VALUES.

1.8 DDS DS0A/B DATA INTERFACE MODULE

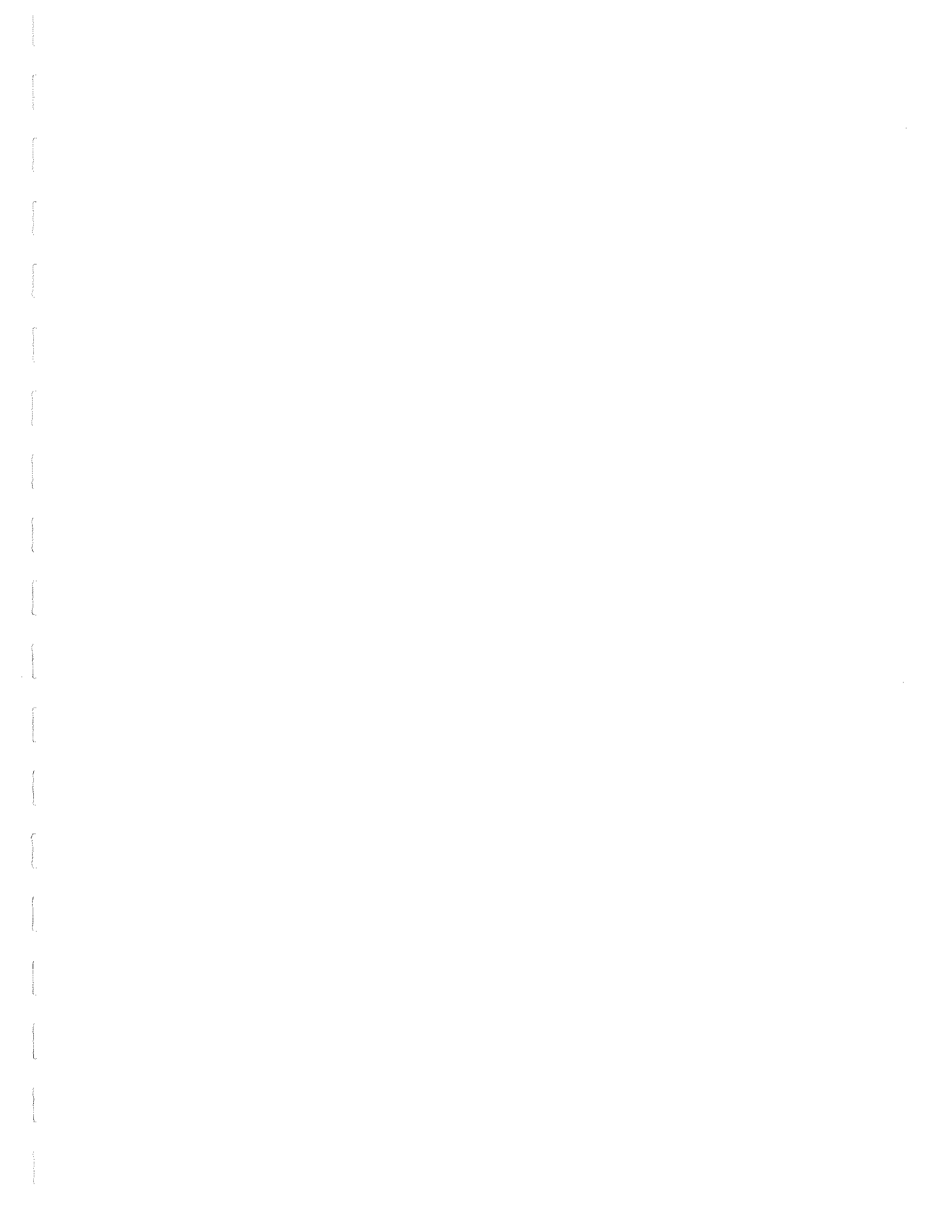


The DDS DS0A/B Data Interface Module meets Bell System Specifications for DDS testing, analyzing DS0A or DS0B circuits transmitting at 2.4, 4.8, 9.6, 19.2, or 56 kb/s as well as 64 kb/s clear channel. It provides alternating and latching loopbacks and controls MJUs for multipoint network testing.

Using the DDS DS0A/B Data Interface Module, the FIREBERD 6000 can isolate DDS circuit problems occurring at (or between) various DDS network components (e.g., DSUs, CSUs, OCUs, DS0-DPs, MJUs, SRDMs, etc.). Error analysis can be performed via straightaway tests, and latching or alternating loopback tests.

NOTE: An 8 kHz byte clock and a 64 kHz bit clock are required for all DDS testing. Both are normally obtained from the DDS channel bank, and are typically accessed using an A-5 connector or 9-pin D connector; the DDS DS0A/B Interface accepts the 9-pin D connector.

PATTERNS:	All except FOX. Byte encoder included.
GEN CLK SOURCE:	INTF only.
DATA RATES:	2.4, 4.8, 9.6, 19.2, 56, and 64 kb/s, and respective secondary channels.
TIMING MODES:	SYNC only. (Switch is disabled.)
FRONT PANEL CONTROL?	Yes.
CABLES/CONNECTORS:	DS0 clock cable (10') 9-pin D to 9-pin office D male OIU (10') adaptor Transmit and receive bantam jacks



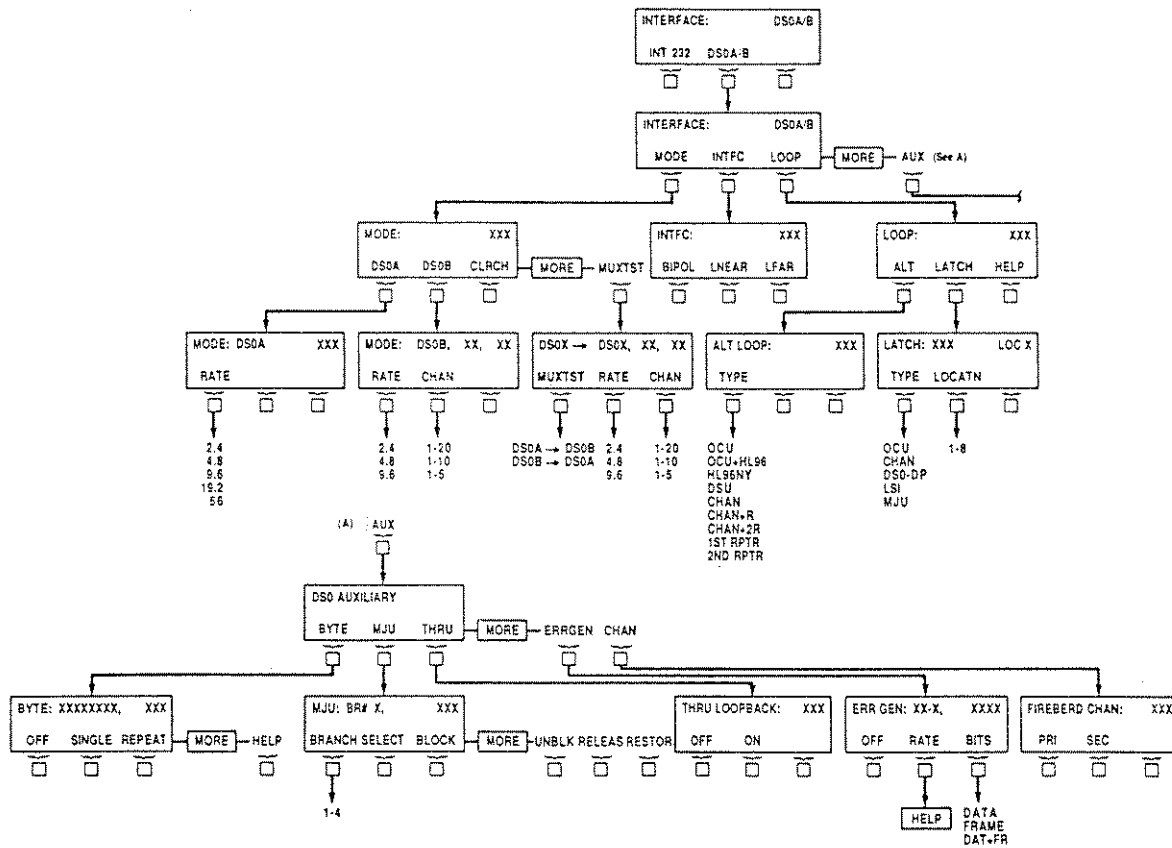


Figure 1-6
DS0A/DS0B Menu Tree

1.8.1 Far-End OCU Loopback Test Set-Up

Table 1-9 describes how the FIREBERD 6000 can be set up to perform a far-end OCU loopback test using the DDS DS0A/B Data Interface Module.

IMPORTANT: If your test fails to run, Section 1.11 offers additional information about DDS testing.



Table 1-9
Far-End OCU Loopback Test Set-Up

Step	Activity
1.	With the power to the FIREBERD turned off, insert the DS0A/DS0B Data Interface Module in the designated rear-panel slot.
2.	Press the POWER switch to apply power to the FIREBERD 6000. NOTE: If the FIREBERD 6000 is in Self-Loop mode after power-up, disengage the SELF LOOP switch.
3.	Select a test data pattern using the DATA switch. SUGGESTION: The recommended patterns for this test are 63, 511, or 2047.
4.	Set the GEN CLK switch to the INTF position.
5.	Using the MENU switch: a. Configure the DDS DS0A/B Data Interface Module using INTF SETUP. Select these softkeys: <ol style="list-style-type: none"> 1. Δ DS0A/B to select the DS0A/B Data Interface. 2. MODE to select the data format. 3. DS0A to select the DS0A format. 4. RATE to select the desired data rate. 5. Δ Δ INTFC to access the data coding. 6. BIPOLAR to select bipolar data coding. 7. Δ LOOP to access the loop selections. 8. LATCH to select latching loops. 9. TYPE to select OCU loopbacks. 10. LOCATN to select location 1. b. Configure the FIREBERD for a TIMED or CONTINUOUS test using the TEST INTERVAL switch (see Appendix C). c. If hard-copy test results are desired, set the print event criteria using PRINT EVENT, then enable the printer control block (located to the left of the POWER switch) by setting the OFF/ON switch to the ON position. (See Appendix D for a sample DDS print event.)
6.	Using the appropriate cables, connect the FIREBERD 6000 to the DS0-DP, and to the bit and byte clocks.
7.	Once the FIREBERD is properly configured and cabled, initiate a loop code sequence by pressing the LOOP UP switch. PRESS LOOP DOWN AT THE CONCLUSION OF THE TEST TO RESTORE THE CIRCUIT TO NORMAL OPERATION.
Legend: Δ = Press the UP ARROW key MORE = Press the MORE key	



Table 1-9
Far-End OCU Loopback Test Set-Up (Continued)

Step	Activity
8.	<p>Check that the SYNC LED (upper right corner of the unit) is illuminated.</p> <p>RESULT: The FIREBERD has achieved pattern synchronization and is gathering test results. (Section 1.10 lists all DDS test results.)</p>

1.8.2 Far-End DSU Loopback Test Set-Up of Multipoint Circuits

Table 1-10 describes how the FIREBERD 6000 can be set up to perform a far-end DSU loopback test of multipoint circuits using the DDS DS0A/B Data Interface Module.

IMPORTANT: If your test fails to run, Section 1.11 offers additional information about DDS testing.

Table 1-10
Far-End DSU Loopback Test Set-Up of Multipoint Circuits

Step	Activity
1.	<p>With the power to the FIREBERD turned off, insert the DS0A/DS0B Data Interface Module in the designated rear-panel slot.</p>
2.	<p>Press the POWER switch to apply power to the FIREBERD 6000.</p> <p>NOTE: If the FIREBERD 6000 is in Self-Loop mode after power-up, disengage the SELF LOOP switch.</p>
3.	<p>Select a test data pattern using the DATA switch.</p> <p>SUGGESTION: The recommended patterns for this test are 63, 511, or 2047.</p>
4.	<p>Set the GEN CLK switch to the INTF position.</p>
5.	<p>Using the MENU switch:</p> <ol style="list-style-type: none"> a. Configure the DDS DS0A/B Data Interface Module using INTF SETUP. Select these softkeys: <ol style="list-style-type: none"> 1. DS0A/B to select the DS0A/B Data Interface. 2. MODE to select the data format. 3. DS0A to select the DS0A format. 4. RATE to select the desired data rate.

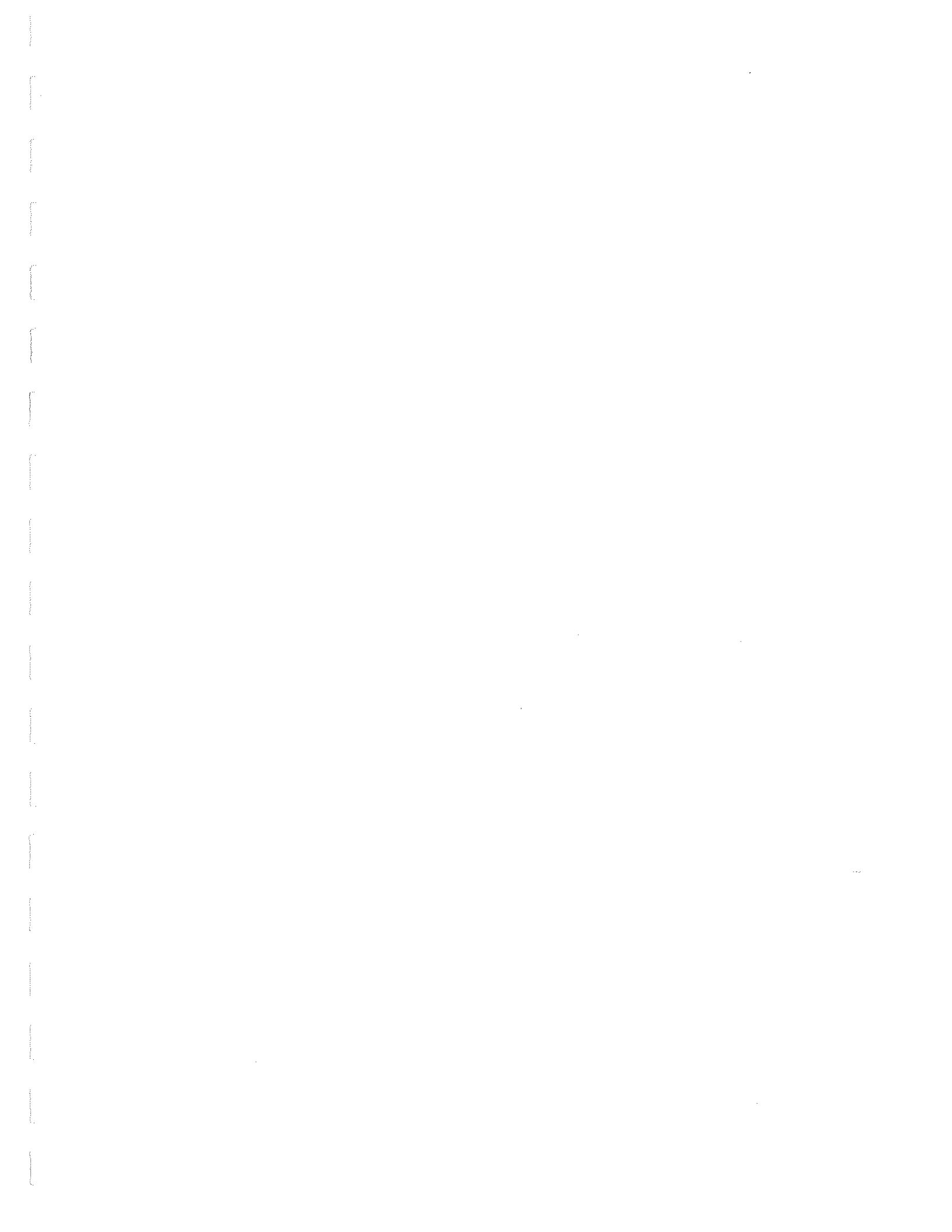


Table 1-10
Far-End DSU Loopback Test Set-Up of Multipoint Circuits (Continued)

Step	Activity
5. (Cont.)	<p>5. Δ Δ INTFC to access the data coding.</p> <p>6. LFAR to select far-end loop.</p> <p>7. Δ LOOP to access the loop selections.</p> <p>8. ALT to select alternating loop codes.</p> <p>9. TYPE to select DSU loopbacks.</p> <p>10. Δ Δ MORE AUX. MJU to access MJU controls.</p> <p>11. BRANCH to identify the desired branch (1-4) for the DSU loopback.</p> <p>12. SELECT to select the branch specified.</p> <p>b. Configure the FIREBERD for a TIMED or CONTINUOUS test using the TEST INTERVAL switch (see Appendix C).</p> <p>c. If hard-copy test results are desired, set the print event criteria using PRINT EVENT, then enable the printer control block (located to the left of the POWER switch) by setting the OFF/ON switch to the ON position. (See Appendix D for a sample DDS print event.)</p> <p>6. Using the appropriate cables, connect the FIREBERD 6000 to the DS0-DP, and to the bit and byte clocks.</p> <p>7. Once the FIREBERD is properly configured and cabled, initiate a loop code sequence by pressing the LOOP UP switch. PRESS LOOP DOWN AT THE CONCLUSION OF THE TEST TO RESTORE THE CIRCUIT TO NORMAL OPERATION.</p> <p>8. Check that the SYNC LED (upper right corner of the unit) is illuminated.</p> <p>RESULT: The FIREBERD has achieved pattern synchronization and is gathering test results. (Section 1.10 lists all DDS test results.)</p>
<p>Legend: Δ = Press the UP ARROW key MORE = Press the MORE key</p>	

1.8.3 Basic Straightaway Test

A DSOA/DS0B straightaway test requires two FIREBERDs. For example, Figure 1-7 shows a FIREBERD 6000 equipped with a DDS DSOA/DS0B Data Interface Module and a second FIREBERD with its built-in RS-232 interface. By performing a straightaway test on the primary or secondary channel between the channel bank and DSU, you can evaluate the performance of the OCU, the local loop, and the CSU/DSU.



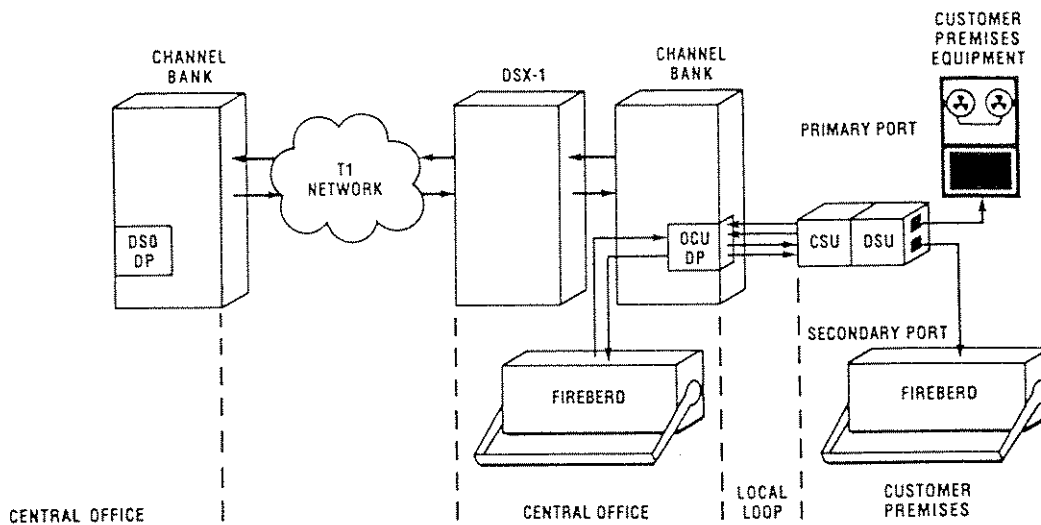


Figure 1-7
Straightaway Test Configuration

Table 1-11 describes how the FIREBERD 6000 can be set up to perform a straightaway test using the DS0A/DS0B Data Interface Module. (See Section 1.2.1 for information about configuring the internal RS-232 Data Interface.)

IMPORTANT: If your test fails to run, Section 1.11 offers additional information about DDS testing.

Table 1-11
Straightaway Test Set-Up

Step	Activity
1.	With the power to the FIREBERD turned off, insert the DS0A/DS0B Data Interface Module in the designated rear-panel slot.
2.	Press the POWER switch to apply power to the FIREBERD 6000. NOTE: If the FIREBERD 6000 is in Self-Loop mode after power-up, disengage the SELF LOOP switch.
3.	Select a test data pattern using the DATA switch. SUGGESTION: The recommended patterns for this test are 511 or 2047.
4.	Set the GEN CLK switch to the INTF position.

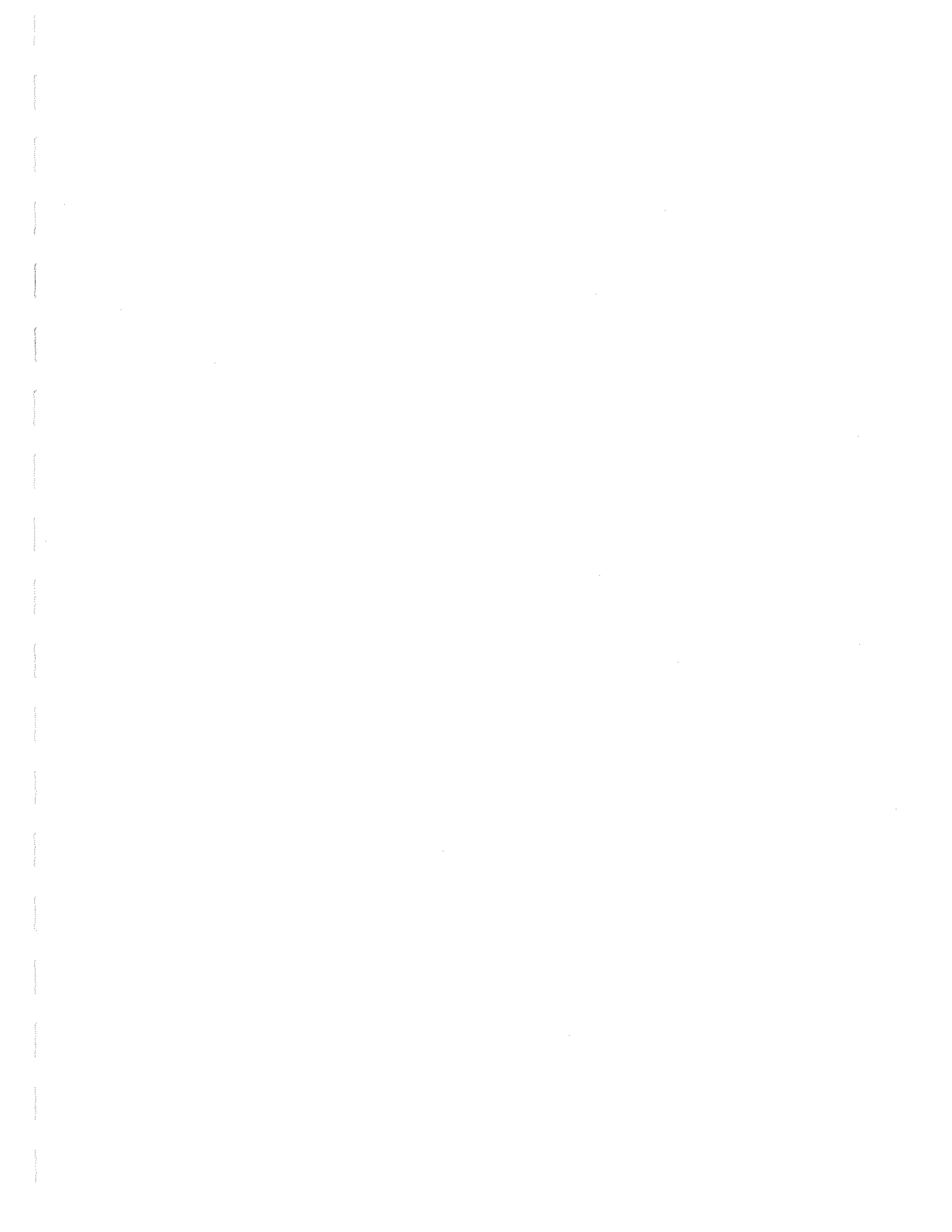
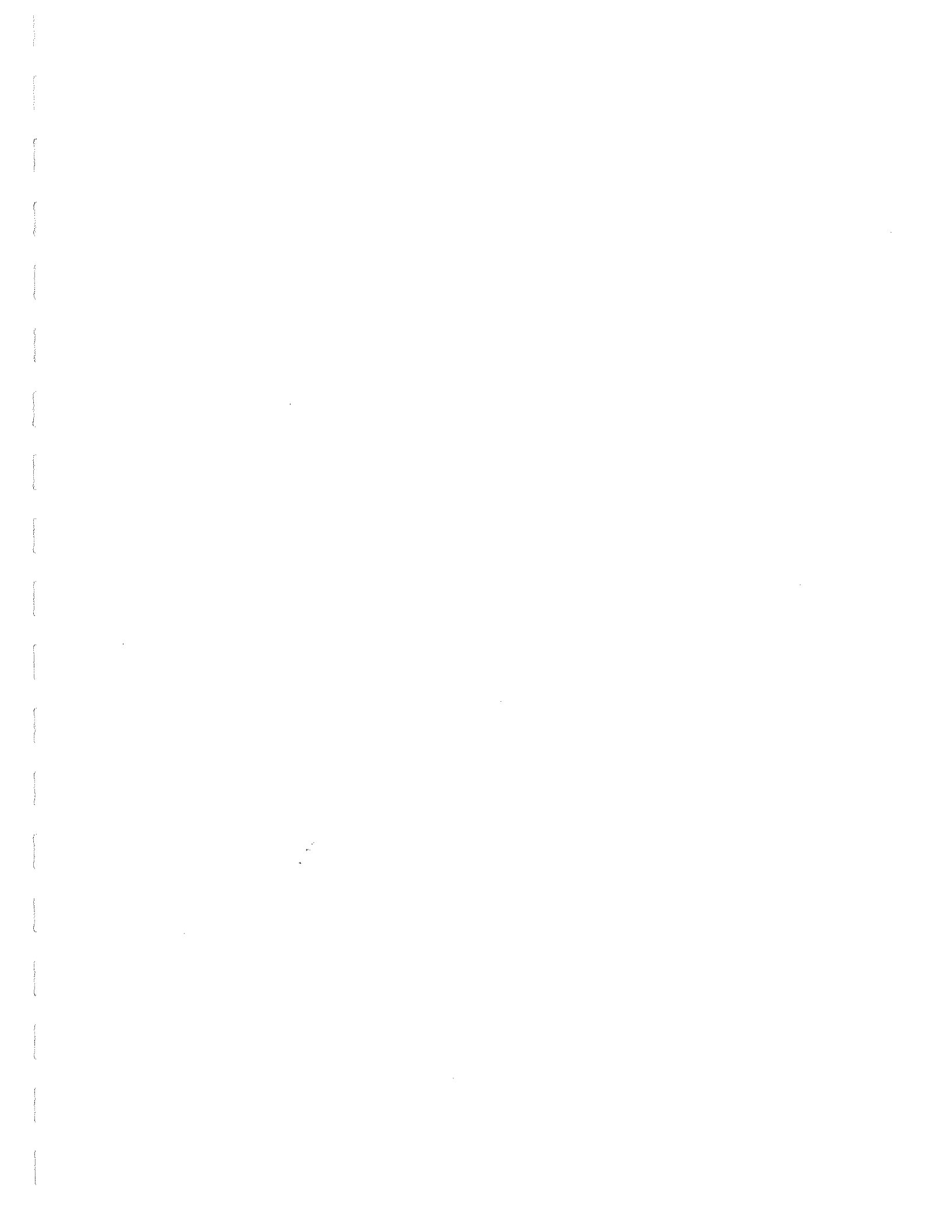
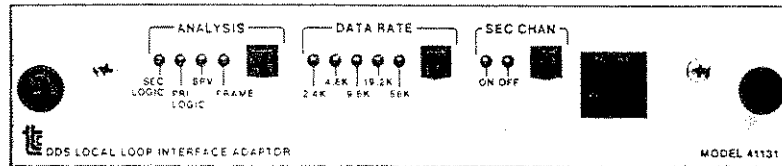


Table 1-11
Straightaway Test Set-Up (Continued)

Step	Activity
5.	<p>Using the MENU switch:</p> <p>a. Configure the DDS DS0A/B Data Interface Module using INTF SETUP. Select these softkeys:</p> <ol style="list-style-type: none"> 1. DS0A/B to select the DS0A/B Interface. 2. MODE to select the data format. 3. DS0A to select the DS0A format. 4. RATE to select the desired data rate. 5. Δ Δ INTFC to access the data coding. 6. BIPOL, LNEAR. or LFAR, as required. 7. Δ MORE AUX to select the interface auxiliary function menu. 8. MORE CHAN to select the primary or secondary channel function. 9. PRI or SEC to select primary or secondary channel testing, as appropriate. <p>b. Configure the FIREBERD for a TIMED or CONTINUOUS test using the TEST INTERVAL switch (see Appendix C).</p> <p>c. If hard-copy test results are desired, set the print event criteria using PRINT EVENT, then enable the printer control block (located to the left of the POWER switch) by setting the OFF/ON switch to the ON position. (See Appendix D for a sample DDS print event.)</p>
6.	<p>Using the appropriate cables, connect the FIREBERD 6000 with the DS0A/B Data Interface Module to the OCU, and to the bit and byte clocks. Connect the second FIREBERD to the primary or secondary channel port on the CPE side of the DSU.</p>
7.	<p>Check that the SYNC LED (upper right corner of the unit) is illuminated.</p>
<p>RESULT: The FIREBERD has achieved pattern synchronization and is gathering test results. (Section 1.10 lists all DDS test results.)</p>	
<p>Legend: Δ = Press the UP ARROW key MORE = Press the MORE key</p>	



1.9 DDS LOCAL LOOP DATA INTERFACE MODULE



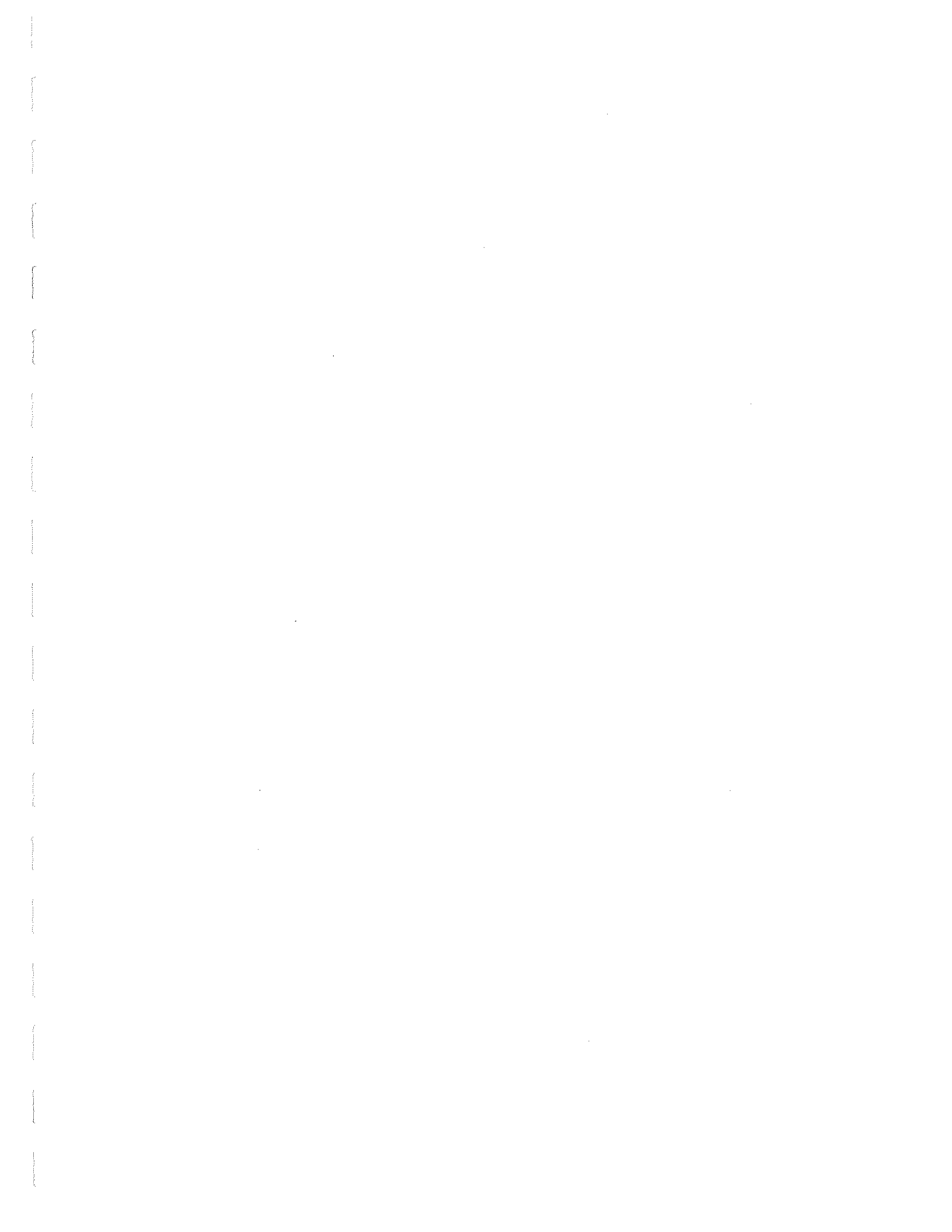
The DDS Local Loop Data Interface gives the FIREBERD 6000 the ability to test and analyze the four-wire DDS local loop from either the customer premises or the central office. Straightaway, channel loopback, or network loopback tests are all possible. The interface complies with Bellcore TA-TSY-000055, TA-TSY-000077, TA-TSY-000083, TR-NPL-000157, AT&T PUB 62120, 62310, CB126, and CB141.

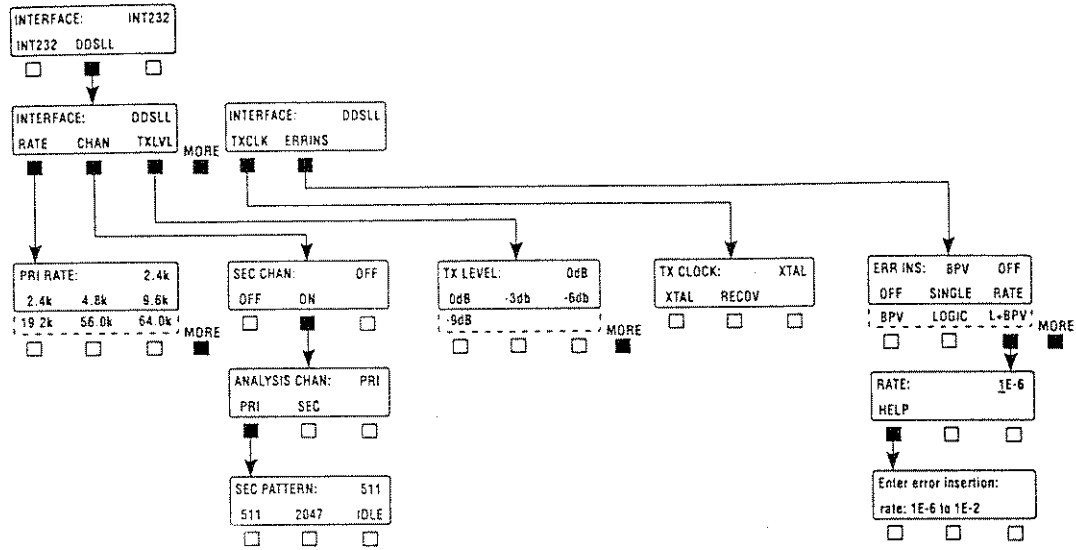
PATTERNS:	All except FOX*, USER1*, USER2*, and USER3*.
GEN CLK SOURCE:	INTERNAL, INTERFACE, and BNC.
DATA RATES:	2.4, 4.8, 9.6, 19.2, 56, and 64 kb/s.
TIMING MODES:	INTF only. (Switch is disabled.)
FRONT PANEL CONTROL?	Yes.
CABLES/CONNECTORS:	RJ45 to RJ45 cable (14') RJ45 cable to four alligator clips (10')

*Valid pattern when the Synchronous User Patterns Option (4006) is installed.

1.9.1 Network Loopback Test Set-Up (Primary Channel)

Figure 1-9 shows a FIREBERD 6000 equipped with a DDS Local Loop Data Interface Module at the customer premises. A manual (i.e., hard) loopback at the OCU sends the transmitted data back to the FIREBERD for analysis. Once the loopback is established, the FIREBERD can test the network from the customer side (or DROP side) of the OCU to the location of the loopback.





NOTE: If PRI RATE is set to 64.0k, the CHAN (Secondary Channel) selection is not available.

Figure 1-8
DDS Local Loop Menu Tree

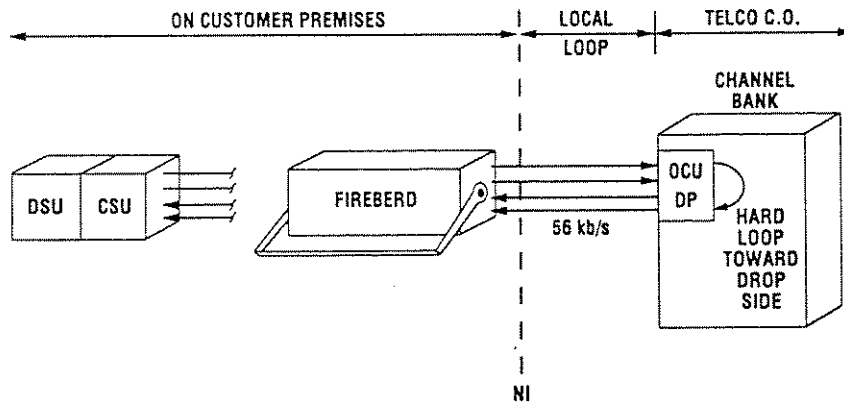


Figure 1-9
Network Loopback Test

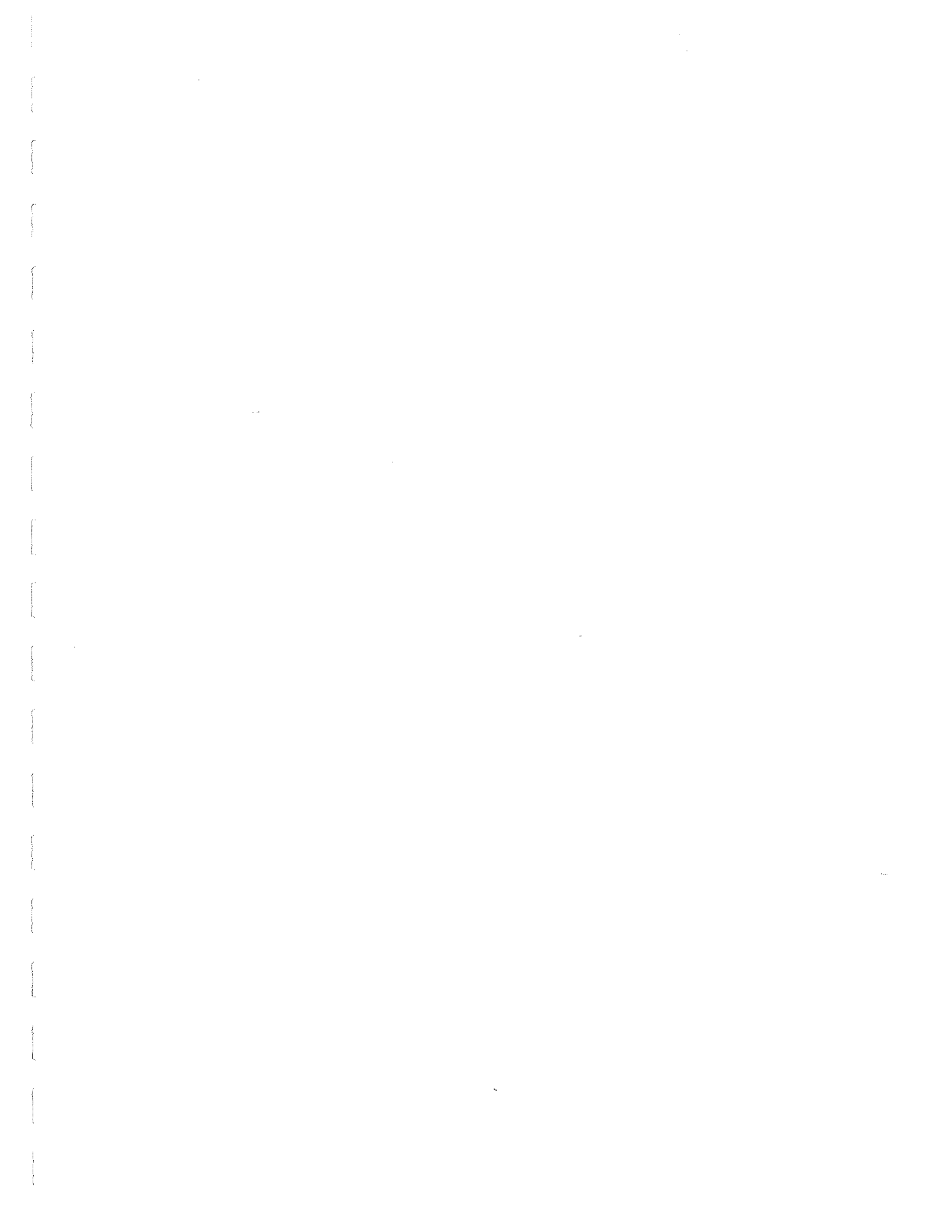


Table 1-12 describes how a FIREBERD 6000 equipped with a DDS Local Loop Data Interface Module can be set up to test a primary channel using network loopbacks. Note that these procedures assume the presence of a secondary channel, and that a hard loopback has been established; since the DDS Local Loop Data Interface Module does not establish loopbacks, all network loopbacks must be established from within the DDS network.

IMPORTANT: If your test fails to run, Section 1.11 offers additional information about DDS testing.

Table 1-12
Network Loopback Test Set-Up (Primary Channel)

Step	Activity
1.	With the power to the FIREBERD turned off, insert the DDS Local Loop Data Interface Module in the designated rear-panel slot.
2.	Press the POWER switch to apply power to the FIREBERD 6000. NOTE: If the FIREBERD 6000 is in Self-Loop mode after power-up, disengage the SELF LOOP switch.
3.	Select a test data pattern using the DATA switch. SUGGESTION: The recommended patterns for this test are 511 or 2047. NOTE: When using the DDS Local Loop Data Interface Module, the GEN CLK switch is automatically set to the INTF position. Additionally, the TIMING MODE switch is disabled; therefore, no setting is required.
4.	Using the MENU switch: a. Configure the DDS Local Loop Data Interface Module using INTF SETUP. Select these softkeys: 1. DDSLL to access the DDS Local Loop Data Interface Module. 2. RATE to access the data rate menu. 3. MORE 56.0K to test the 56 kb/s circuit shown in Figure 1-9, or any pattern that is appropriate for your test. 4. Δ CHAN to enter the channel selection menu. 5. ON to indicate the presence of a secondary channel. 6. PRI to select primary channel analysis. 7. 511, 2047, or IDLE as secondary pattern selection. (Primary pattern is selected via DATA switch.) 8. $\Delta \Delta \Delta$ TX LEVEL to access the transmit level menu. 9. Δ MORE 0 dB to add no additional loss to the transmit level. 10. TXCLK to access the timing source menu. 11. RECOV to recover timing from the DDS network. 12. Δ ERRINS to select the error insert menu. 13. OFF to turn off error insertion.
Legend: Δ = Press the UP ARROW key MORE = Press the MORE key	



Table 1-12
Network Loopback Test Set-Up (Primary Channel) (Continued)

Step	Activity
4. (Cont.)	b. Configure the FIREBERD for a TIMED or CONTINUOUS test using the TEST INTERVAL switch (see Appendix C). c. If hard-copy test results are desired, set the print event criteria using PRINT EVENT, then enable the printer control block (located to the left of the POWER switch) by setting the OFF/ON switch to the ON position. (See Appendix D for a sample DDS print event.)
5.	Using the appropriate cables, connect the FIREBERD 6000 to the equipment under test.
6.	Check that the SYNC LED (upper right corner of the unit) is illuminated.
	RESULT: The FIREBERD has achieved pattern synchronization and is gathering test results. (Section 1.10 lists all DDS test results.)

1.9.2 Channel Loopback Test Set-Up (Without Secondary Channel)

Figure 1-10 shows a FIREBERD 6000 with a DDS Local Loop Data Interface Module connected to the local loop. Another instrument at the serving test center sends a channel loopback in the direction of the FIREBERD. The FIREBERD recognizes and responds to the channel loopback by placing itself in a loop towards the network. The serving test center performs the bit error test; the FIREBERD can provide level, current, and frame analysis in-service.

When performing a channel loopback test, always do the following:

1. Configure the FIREBERD as described in Table 1-13.
2. Connect to the local loop. If the FIREBERD is in Self-Loop mode after power-up, disengage the SELF LOOP switch.
3. Issue a channel loopback from the instrument in the serving test center.

RESULT: The FIREBERD 6000 establishes a channel loopback; the presence of the channel loopback is indicated by the illumination of the ALM1 indicator. Additionally, the message DDS LOCAL LOOP CSU LOOPBACK momentarily appears in the results display.



1

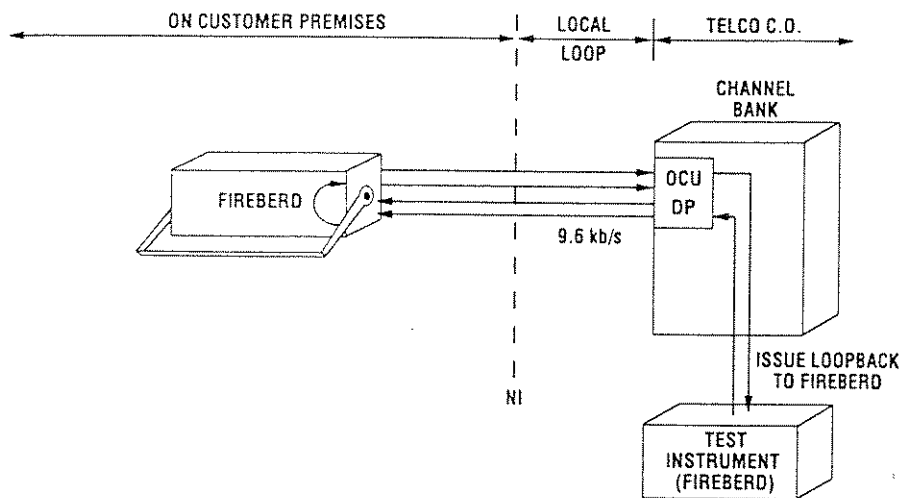


Figure 1-10
Channel Loopback Test

Table 1-13 describes how a FIREBERD 6000 equipped with DDS Local Loop Data Interface Module can be set up to perform a channel loopback test. Note that these procedures assume that a secondary channel is *not* present.

IMPORTANT: If your test fails to run, Section 1.11 offers additional information about DDS testing.

Table 1-13
Channel Loopback Test Set-Up (Without Secondary Channel)

Step	Activity
1.	With the power to the FIREBERD turned off, insert the DDS Local Loop Data Interface Module in the designated rear-panel slot.
2.	Press the POWER switch to apply power to the FIREBERD 6000. NOTE: If the FIREBERD 6000 is in Self-Loop mode after power-up, disengage the SELF LOOP switch.
3.	Select a test data pattern using the DATA switch. SUGGESTION: The recommended patterns for this test are 511 or 2047.

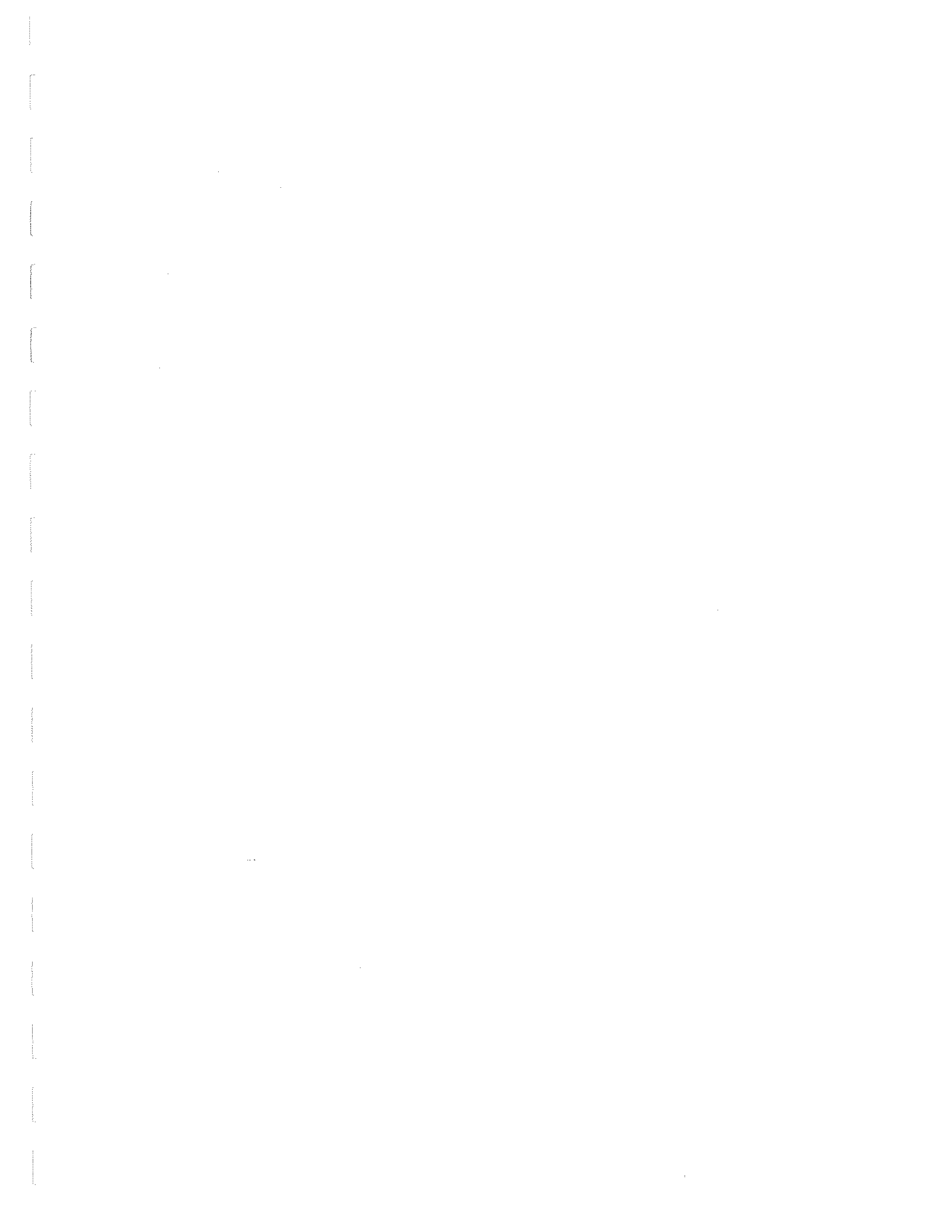


Table 1-13
Channel Loopback Test Set-Up (Without Secondary Channel) (Continued)

Step	Activity
4.	<p>NOTE: When using the DDS Local Loop Data Interface Module, the GEN CLK switch is automatically set to the INTF position. Additionally, the TIMING MODE switch is disabled; therefore, no setting is required.</p> <p>Using the MENU switch:</p> <ul style="list-style-type: none"> a. Configure the DDS Local Loop Data Interface Module using INTF SETUP. Select these softkeys: <ul style="list-style-type: none"> 1. DDSLL to access the DDS Local Loop Data Interface Module. 2. RATE to access the data rate menu. 3. 9.6K to test the 9.6 kb/s circuit shown in Figure 1-10. 4. Δ CHAN to enter the channel selection menu. 5. OFF to indicate that secondary channel is not present. 6. Δ TX LEVEL to access the transmit level menu. 7. 0 dB to add no additional loss to the transmit level. 8. Δ MORE TXCLK to access the timing source menu. 9. RECOV to recover timing from the DDS network. 10. Δ ERRINS to select the error insert menu. 11. OFF to turn off error insertion. b. Configure the FIREBERD for a TIMED or CONTINUOUS test using the TEST INTERVAL switch (see Appendix C). c. If hard-copy test results are desired, set the print event criteria using PRINT EVENT, then enable the printer control block (located to the left of the POWER switch) by setting the OFF/ON switch to the ON position. (See Appendix D for a sample DDS print event.) <p>5. Using the appropriate cables, connect the FIREBERD 6000 to the equipment under test.</p> <p>6. Check that the SYNC LED (upper right corner of the unit) is illuminated.</p> <p>RESULT: The FIREBERD has achieved pattern synchronization and is gathering test results. (Section 1.10 lists all DDS test results.)</p>
<p>Legend: Δ = Press the UP ARROW key MORE = Press the MORE key</p>	

1.10 DDS DS0A/DS0B AND DDS LOCAL LOOP TEST RESULTS

Tables 1-14 and 1-15 show the test results that are available with the DS0A/DS0B and Local Loop Data Interface Modules, respectively. These results can be collected via printer or can be viewed at the ANALYSIS display window at the conclusion of any test.

1
2
3
4
5
6
7
8
9
10
11
12
13
14
15
16
17
18
19
20
21
22
23
24
25

Appendix B offers a glossary of all test results offered by the FIREBERD 6000.

Table 1-14
DDS DS0A/B Test Results

Category	Results			
ERROR	BER PAT SLIP	BLOCKS BIT ERRS	BLK ERRS AVG BER	AVG BLER
PERFORMANCE	DEG MIN UNA SEC BER-SES	%DEG MIN AVL SEC GER SEC	SES %AVL SEC G EFS	%SES ERR-SES G %EFS
TIME	ERR EAS %PAT SEC	E A SEC ELAP SEC	E F EAS TIME	PATL SEC DATE
SIGNAL	RCV FREQ	GEN FREQ	RCV BYTE	RCV CODE
T-CARRIER*	FRA ERR	FE RATE	AVG FERR	FRA LOSS
ALARM	PATLOSS	DAT LOSS	CLK LOSS	PWR LOSS

*Applicable only when receiving DS0B or DS0A at 19.2 kb/s.

Table 1-15
DDS Local Loop Test Results

Category	Results			
ERROR	BER PAT SLIP	BLOCKS BIT ERRS	BLK ERRS AVG BER	AVG BLER
PERFORMANCE	DEG MIN %AVL SEC	%DEG MIN G %EFS	UNA SEC	AVL SEC
TIME	ELAP SEC	TIME	DATE	PATL SEC
SIGNAL	R LVL V	R LVL dB	DAT RATE	SIMPX CUR
T-CARRIER	BPV AVG FER	AVG BPVR	BPV Rate	FRA ERR
ALARM	PAT LOSS	PWR LOSS	SIG LOSS	

1.11 NOTES ON DDS TESTING

If your test fails to run after completing the set-up procedures for your DDS application, the sections that follow may lead you to the solution. Note that only the most likely potential problem areas are addressed; if your test still fails after exploring these problem areas, call TTC's toll-free number (1-800-638-2049) for technical assistance.

1.11.1 Non-Availability of the Selected Timing Source

If either the GEN CLK switch or the NO CLK LED is illuminated, the FIREBERD 6000 cannot receive the clock from the selected timing source. In such instances, check your cables to ensure that the bit and byte clocks are properly connected.

1.11.2 Setting Auxiliary Functions

Sometimes the setting of one of the auxiliary functions may not be appropriate for your specific test. Use Auxiliary Function 99 to reset all of your auxiliary functions to their default states.

CAUTION:

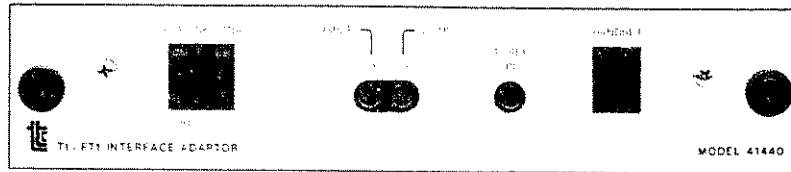
THE USE OF THIS FUNCTION RESETS ALL AUXILIARY FUNCTIONS VALUES.

1.11.3 Latching Loopbacks

Latching loopbacks have only recently been introduced into the Digital Data System. Many circuits do not respond to latching loop codes. When this condition occurs, use alternating loop codes.

1
2
3
4
5
6
7
8
9
10
11
12
13
14
15
16
17
18
19
20
21
22
23
24
25
26
27
28
29
30
31
32
33
34
35
36
37
38
39
40
41
42
43
44
45
46
47
48
49
50
51
52
53
54
55
56
57
58
59
60
61
62
63
64
65
66
67
68
69
70
71
72
73
74
75
76
77
78
79
80
81
82
83
84
85
86
87
88
89
90
91
92
93
94
95
96
97
98
99
100

1.12 T1/FT1 INTERFACE MODULE



The T1/FT1 Interface Module complies with AT&T Publications 41541, 62411, 54016, 54019, and 54019A for T1, ESF, and Fractional T1. It provides the ability to test T1, Fractional T1, voice, or the ESF data link. Other modes of operation include test loopback (TLB), line loopback (LLB), and RS-232 receive/transmit.

PATTERNS:	All except FOX*, USER1*, USER2*, and USER3*.
GEN CLK SOURCE:	INTRNL, INTF, and BNC.
DATA RATES:	1.544 Mb/s, 1.536 Mb/s, 64 kb/s, and 56 kb/s.
TIMING MODES:	Recovered only.
FRONT PANEL CONTROL?	Yes.
CABLES/CONNECTORS:	WECO plug to bantam plug (10') Bantam plug to bantam plug (10') Bantam plug to alligator clips (7') Dual bantam plugs to 15-pin D-type male connector (10') RJ45 to RS-232 cable (16') RJ48C to bantam plugs (10') TJ45S to bantam plugs (10')

*Valid pattern when the Synchronous User Patterns Option (4006) is installed.

1.12.1 End-To-End Fractional T1 Testing

Figure 1-12 shows two FIREBERD 6000s, each equipped with a T1/FT1 Interface Module. Using these two FIREBERDs, it is possible to evaluate the performance of a Fractional T1 circuit end-to-end. Both sides of the circuit are tested with a pattern that is transmitted from both ends of the span.

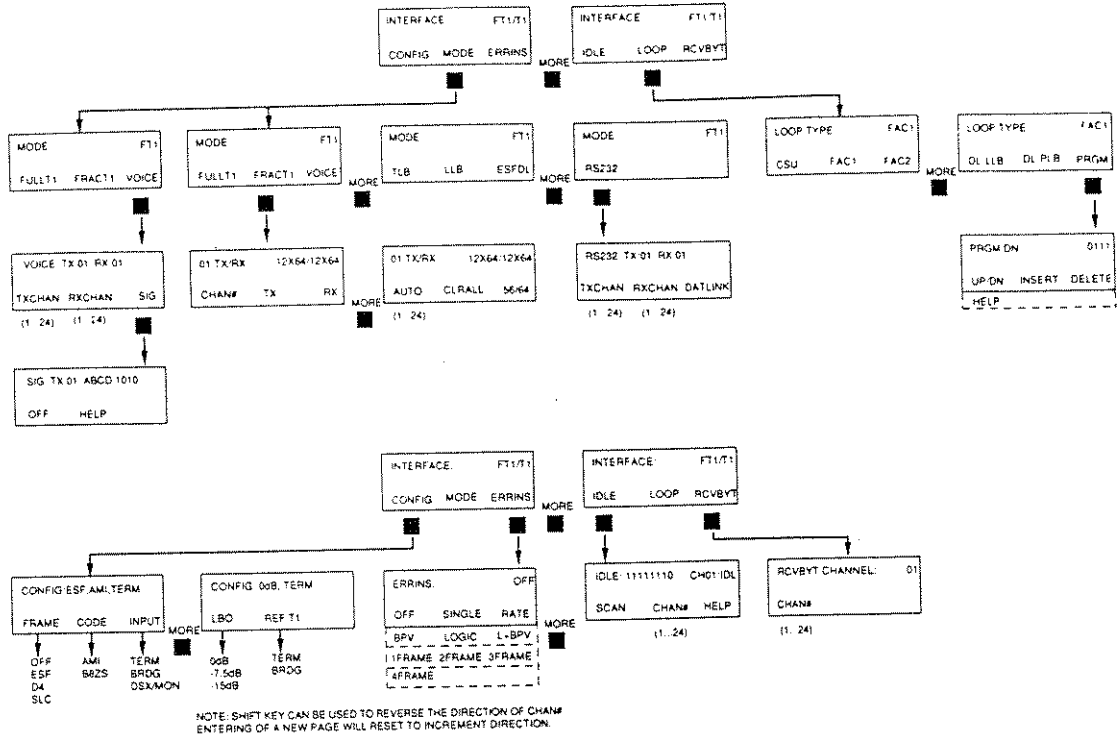


Figure 1-11
T1/FT1 Menu Tree

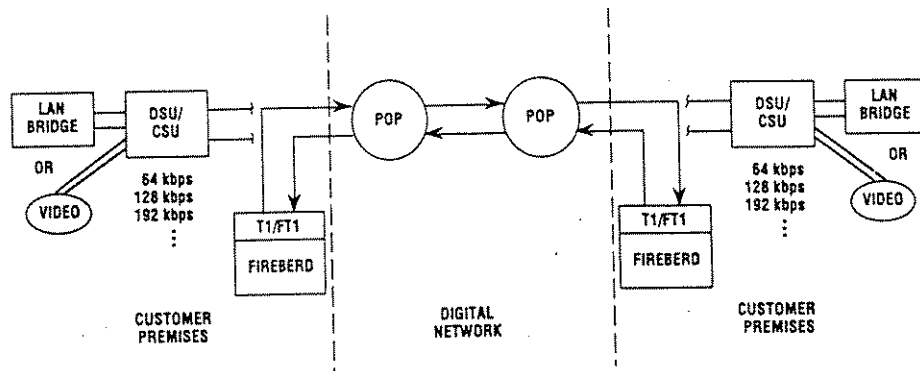
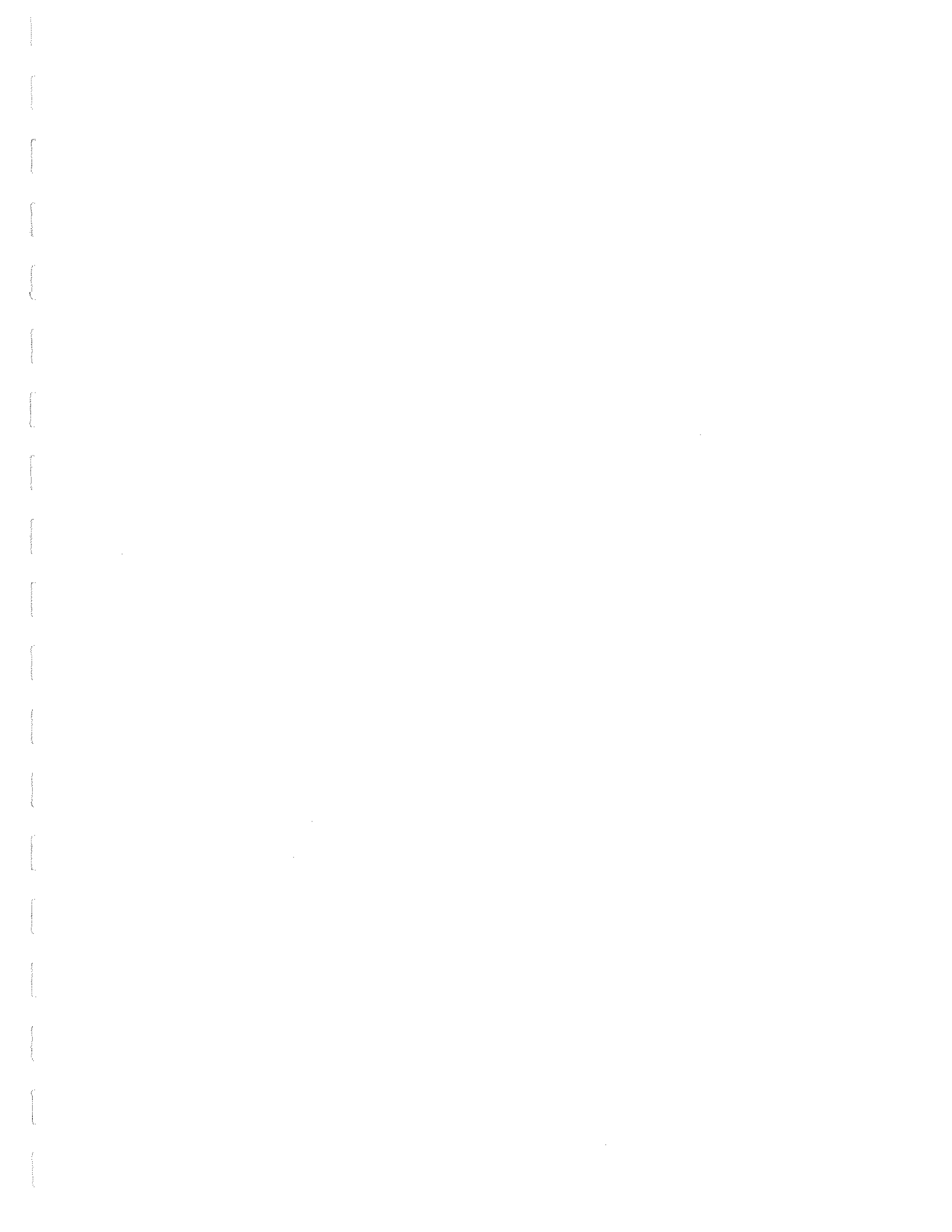


Figure 1-12
End-To-End Fractional T1 Testing



FIREBERD 6000 User's Guide

Table 1-16 describes how the FIREBERD 6000 can be set up to perform an end-to-end Fractional T1 test using the T1/FT1 Interface Module. For purposes of example, these procedures verify the performance of a 384 (6 x 64 kbps) Fractional T1 circuit where channels 1-6 are used for data transmission.

IMPORTANT: If your test fails to run, Section 1.16 offers additional information about T-Carrier testing.

**Table 1-16
End-To-End Fractional T1 Test Set-Up**

Step	Activity
1.	With the power to the FIREBERD 6000 turned off, insert the T1/FT1 Interface Module in the rear-panel interface slot.
2.	Press the POWER switch to apply power to the FIREBERD 6000.
	NOTE: If the FIREBERD 6000 is in Self-Loop mode after power-up, disengage the SELF LOOP switch.
3.	Select a test data pattern using the DATA switch. (Suggestion: QRSS.)
4.	Set the GEN CLK switch to the INTF position.
5.	<p>Using the MENU switch:</p> <p>a. Configure the T1/FT1 Interface using INTF SETUP by selecting these sotkeys:</p> <ol style="list-style-type: none"> 1. T1/FT1 to select the T1/FT1 Interface Module. 2. CONFIG to access the configuration menu. 3. FRAME to select framing. (Example: ESF.) 4. CODE to select coding. (Example: B8ZS.) 5. INPUT to TERM. 6. Δ MODE to access the MODE menu. 7. FRACT1 for Fractional T1 testing. 8. Select T1 channels 1-6 using the CHAN# UP or CHAN# DOWN softkey. Press the TX/RX softkey to designate each channel as an active transmit and receive channel (Example: CH01: TX/RX). 9. MORE Select the Nx64 channel data rate using the 56/64 softkey. 10. Δ Δ ERRINS to access the error insert menu. 11. OFF to turn the error insert off. 12. Δ MORE IDLE to select the idle code. Select the idle code using the > and < keys and the 1 and 0 keys on the keypad. Press the ENTER key to save the changes. Common idle codes: 0111 1111 or 1111 1111. <p>b. Configure the FIREBERD for a TIMED or CONTINUOUS test using the TEST INTERVAL switch (see Appendix C).</p>
<p>Legend: Δ = Press the UP ARROW key MORE = Press the MORE key</p>	

Table 1-16
End-To-End Fractional T1 Test Set-Up (Continued)

Step	Activity
5. (Cont.)	c. If hard-copy test results are desired, set the print event criteria using PRINT EVENT, then enable the printer control block (located to the left of the POWER switch) by setting the OFF/ON switch to the ON position. (See Appendix D for a sample print event set-up for a T1 test.)
6.	Using the appropriate cables, connect the FIREBERD 6000 to the equipment under test.
7.	Check that the SYNC LED (upper right corner of the unit) is illuminated.
RESULT: The FIREBERD is gathering test results. (Section 1.15 lists all T-Carrier test results.)	

1.12.2 Installing and Troubleshooting Customer Premise Equipment

Figure 1-13 shows two FIREBERD 6000s accessing both the DTE and T1 network sides of the Fractional T1 DSU/CSU. FIREBERD #1 is equipped with a V.35 Data Interface Module; FIREBERD #2 is equipped with a T1/FT1 Interface Module. By accessing both sides of the Customer Premise Equipment (CPE), the FIREBERD can test for proper T1 timing and signaling using slips, level, frequency, and jitter measurements, and perform bit error analysis on the designated bandwidth.

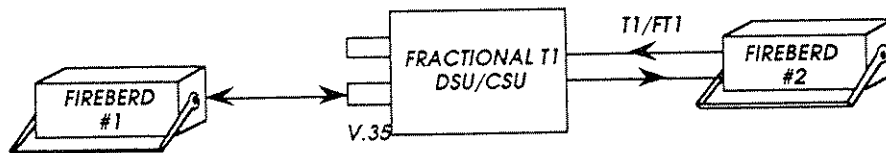


Figure 1-13
Installing and Troubleshooting Customer Premise Equipment

Tables 1-17 and 1-18 describe how each FIREBERD 6000 can be set up to test CPE equipment; Table 1-17 describes the set-up procedures for FIREBERD #1, and Table 1-18 describes the set-up procedures for FIREBERD #2. For purposes of example, these procedures assume the testing of a Fractional T1 DSU/CSU as stand-alone equipment, and that 256 kb/s (4 x 64 kb/s) bit error analysis is performed on four non-contiguous channels.

IMPORTANT: If your test fails to run, Section 1.16 offers additional information about T-Carrier testing.

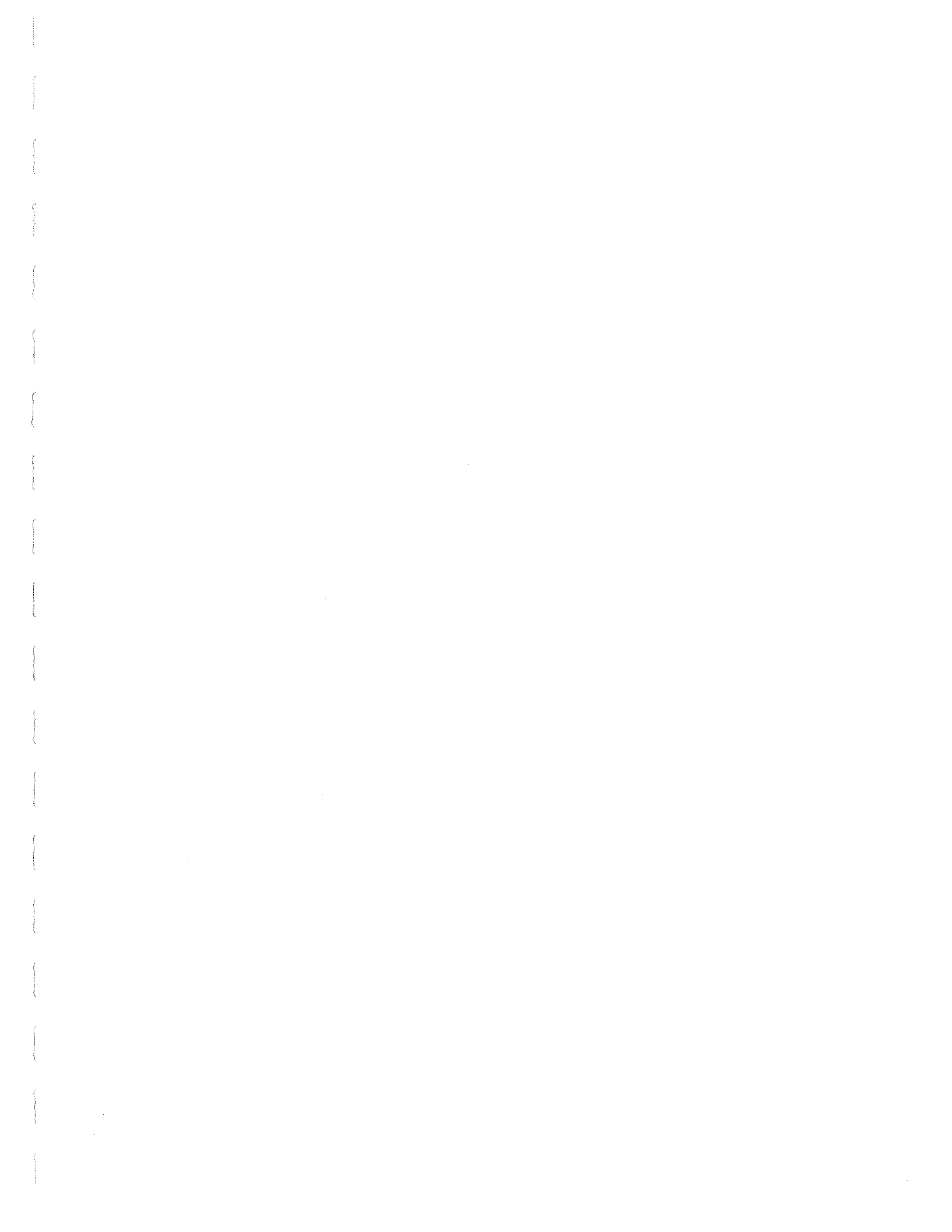


Table 1-17
CPE Test Set-Up (FIREBERD #1)

Step	Activity
1.	With the power to the FIREBERD 6000 turned off, insert the V.35 Data Interface Module in the rear-panel interface slot.
2.	Press the POWER switch to apply power to the FIREBERD 6000. NOTE: If the FIREBERD 6000 is in Self-Loop mode after power-up, disengage the SELF LOOP switch.
3.	Select a test data pattern using the DATA switch.
4.	Set the GEN CLK switch to the INTF position to receive the clock from the DCE.
5.	Since the V.35 Data Interface is not controllable via the FIREBERD 6000 front panel, configure the interface using the switches on the interface as follows: <ul style="list-style-type: none"> a. TRANSMIT CLOCK INVERT switch to NORMAL b. RECEIVE CLOCK INVERT switch to NORMAL c. TIMING MODE switch to 306
6.	Illuminate the RTS and DTR switches located just above the POWER switch to set both signaling leads HIGH.
7.	Set the MENU switch to SYNTH FREQ and set the synthesizer frequency to 256 kbps.

Table 1-18
CPE Test Set-Up (FIREBERD #2)

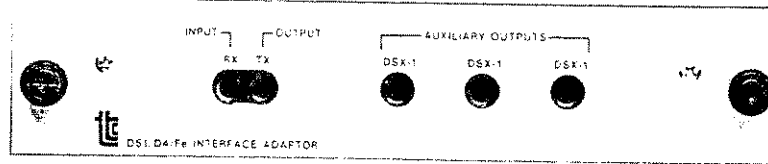
Step	Activity
1.	With the power to the FIREBERD 6000 turned off, insert the T1/FT1 Interface Module in the rear-panel interface slot.
2.	Press the POWER switch to apply power to the FIREBERD 6000. NOTE: If the FIREBERD 6000 is in Self-Loop mode after power-up, disengage the SELF LOOP switch.
3.	Select a test data pattern using the DATA switch. (Example: QRSS).
4.	Set the GEN CLK switch to the INTF position to obtain the transmit clock from the DCE.
5.	Using the MENU switch: <ul style="list-style-type: none"> a. Configure the T1/FT1 Interface Module using INTF SETUP. Make these softkey selections.



Table 1-18
CPE Test Set-Up (FIREBERD #2) (Continued)

Step	Activity
1.	T1/FT1 to select the T1/FT1 Interface Module.
2.	CONFIG to access the configuration menu.
3.	FRAME to select framing (Example: ESF).
4.	CODE to select coding (Example: AMI).
5.	INPUT as required (TERM, BRIDGE, or DSXMON).
6. Δ	MODE to access the MODE menu.
7.	FRACT1 for Fractional T1 testing.
8.	Scroll through the channels using the CHAN# softkey. Press the RX and TX softkeys to select channels 1, 3, 5, and 7.
9. MORE	Select the Nx64 channel data rate using the 56/64 softkey.
10. Δ Δ	ERRINS to access the error insert menu.
11.	OFF to turn off error insertion.
12. Δ MORE	IDLE to set the idle code. Select the idle code using the > and < keys and the 1 and 0 keys on the keypad. Press the ENTER key to save the changes. Common idle codes: 0111 1111 or 1111 1111.
<p>Legend: Δ = Press the UP ARROW key MORE = Press the MORE key</p>	

1.13 DS1/T1/D4/ESF/SLC-96 INTERFACE MODULE



The DS1/T1/D4/ESF/SLC-96 Interface Module meets Bell T1 (DS1) and CCITT 1.544 Mb/s recommendations. The interface also meets AT&T Publication 54016 specifications for extended superframe. In addition to its transmit/receive pair, the interface includes three auxiliary outputs that are capable of providing multiple DS1 signals.

- PATTERNS: All except FOX.
- GEN CLK SOURCE: SYNTH, INTF, and BNC.
- DATA RATES: 1.544 Mb/s.
- TIMING MODES: Recovered only. (Switch is disabled.)
- FRONT PANEL CONTROL? Yes.
- CABLES/CONNECTORS: WECO plug to bantam plug (10')
Bantam plug to bantam plug (10')
Bantam plug to alligator clips (7')

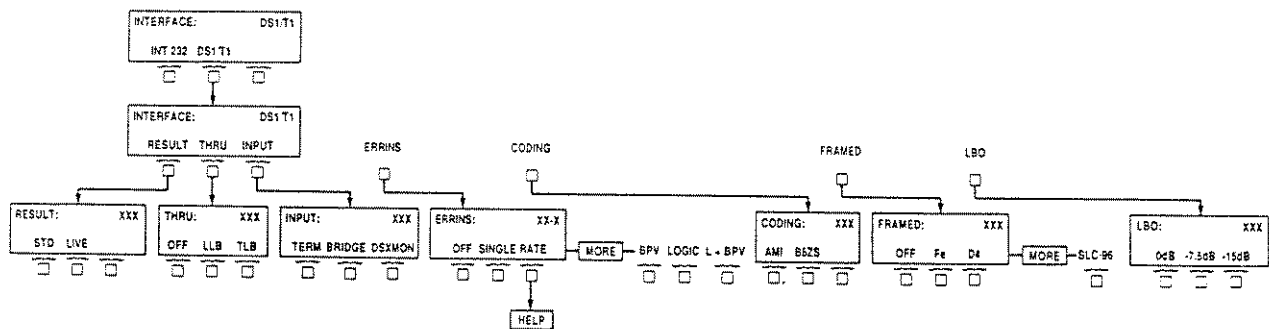
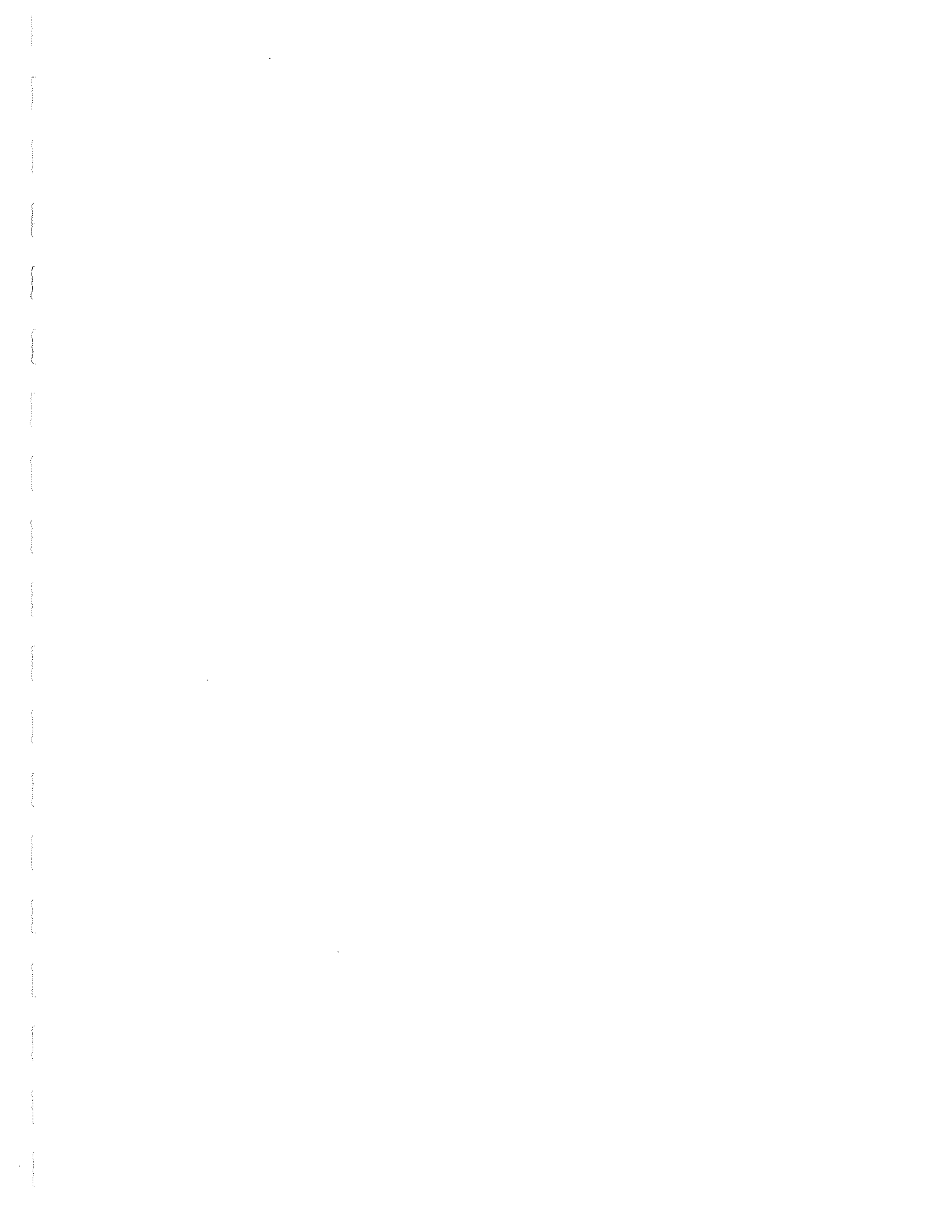


Figure 1-14
DS1/T1/D4/ESF/SLC-96 Interface Module Menu Tree



1.13.1 Remote Loopback Testing

Figure 1-15 depicts a FIREBERD 6000 equipped with a DS1/T1/D4/ESF/SLC-96 Interface Module. The instrument terminates the near end of the T1 network and transmits data to, and receives data from, the far-end CSU. When equipped with this interface, the FIREBERD sends a loop-up code to the far-end CSU; the far-end CSU goes into loopback toward the T1 network and the FIREBERD 6000. By analyzing the received data for errors, the FIREBERD analyzes the performance of the network up to and including the far-end CSU.

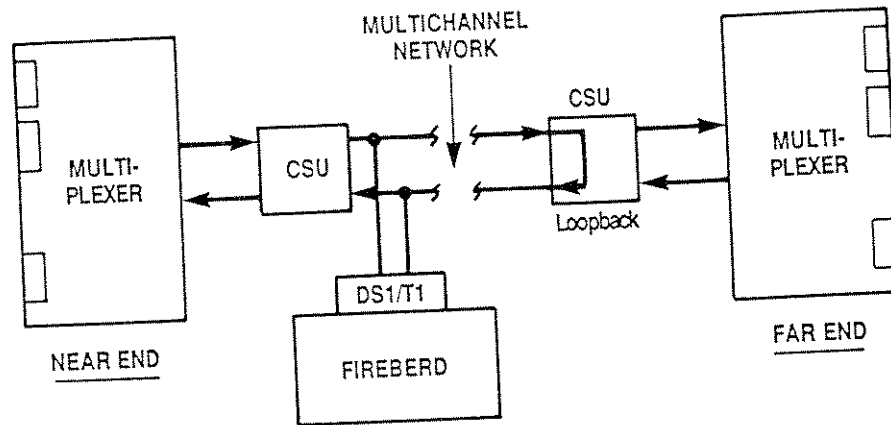


Figure 1-15 Remote Loopback Test

Table 1-19 describes how the FIREBERD 6000 can be set up to perform this T1 loopback test. Please note that these procedures assume D4 framing and AMI coding.

IMPORTANT: If your test fails to run, Section 1.16 offers additional information about T-Carrier testing.

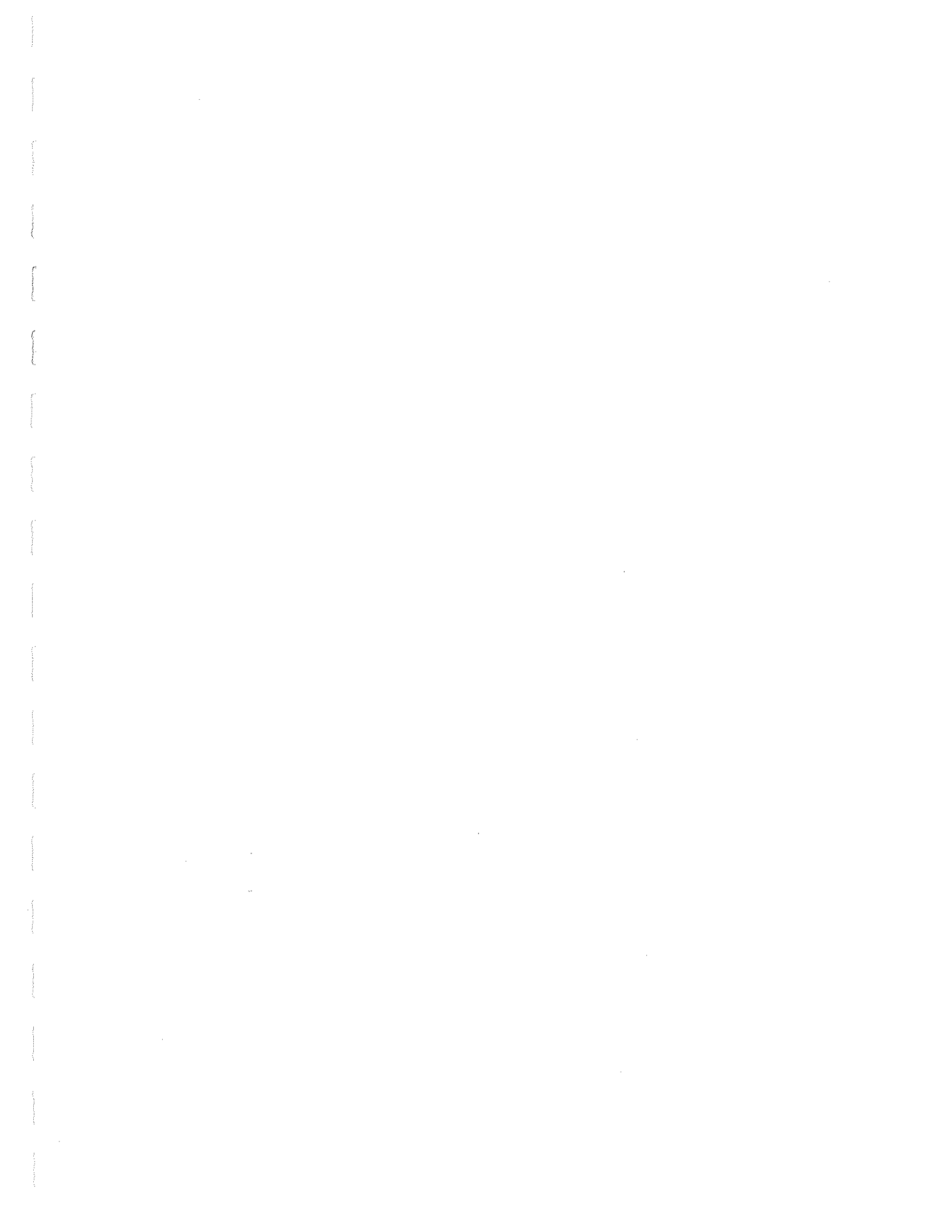
Table 1-19 T1 Loopback Test Set-Up

Step	Activity
1.	With the power to the FIREBERD 6000 turned off, insert the DS1/T1/D4/ESF/SLC-96 Interface Module in the rear-panel interface slot.
2.	Press the POWER switch to apply power to the FIREBERD 6000.
NOTE: If the FIREBERD 6000 is in Self-Loop mode after power-up, disengage the SELF LOOP switch.	



Table 1-19
T1 Loopback Test Set-Up (Continued)

Step	Activity
3.	Select a test data pattern using the DATA switch. (Example: QRSS.)
4.	Set the GEN CLK switch to the SYNTH position to obtain timing from the FIREBERD's internal synthesizer.
5.	<p>Using the MENU switch:</p> <ul style="list-style-type: none"> a. Configure the T1/FT1 Interface Module using INTF SETUP. Make these softkey selections. <ul style="list-style-type: none"> 1. DS1/T1 to select the DS1/T1/D4/ESF/SLC-96 Interface Module. 2. RESULT to access the RESULT menu. 3. STD to select standard test results. 4. Δ THRU to access the THRU menu. 5. OFF to select standard interface operation. 6. Δ INPUT to access the INPUT menu. 7. TERM to select the 100-ohm line terminator. 8. Δ MORE ERRINS to access the error insert menu. 9. OFF to turn off error insertion. 10. Δ CODING to access the CODING menu. 11. AMI to select AMI coding. 12. Δ FRAMED to access the FRAMED menu. 13. D4 to select D4 framing. 14. Δ MORE LBO to select the LBO menu. 15. 0dB to select no line buildout. b. Configure the FIREBERD for a TIMED or CONTINUOUS test using the TEST INTERVAL switch (see Appendix C). c. If hard-copy test results are desired, set the print event criteria using PRINT EVENT, then enable the printer control block (located to the left of the POWER switch) by setting the OFF/ON switch to the ON position. (See Appendix D for a sample print event set-up for a T1 test.)
6.	Using the appropriate cables, connect the FIREBERD 6000 to the equipment under test.
7.	<p>Press the LOOP UP switch (located above the POWER switch) to send a loop code to the far-end CSU.</p> <p>RESULT: The message LOOP CODE TRANSMISSION SUCCESSFUL appears in the MENU display. Press the LOOP DOWN switch to return to normal operation at the conclusion of the test.</p>
8.	<p>Check that the SYNC LED located at the upper right corner of the FIREBERD 6000 is illuminated.</p> <p>RESULT: The FIREBERD has achieved pattern synchronization and is gathering test results. (Section 1.15 lists all T-Carrier test results.)</p>
<p>Legend: Δ = Press the UP ARROW key MORE = Press the MORE key</p>	



1.13.2 End-to-End Testing

Figure 1-16 depicts two FIREBERD 6000, each equipped with a DS1/T1/D4/ESF/SLC-96 Interface Module. FIREBERD #1 connects to the 1.544 Mb/s near-end CSU; FIREBERD #2 connects to the far-end CSU. The instruments simultaneously generate test data and analyze the received data for errors in both directions.

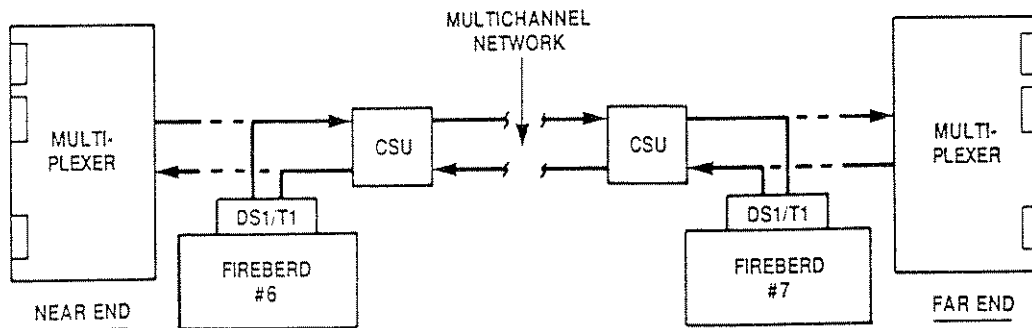


Figure 1-16
End-to-End Testing of a Near-End and Far-End CSU

Table 1-20 describes how the FIREBERD 6000 can be set up to perform an end-to-end T1 test. Please note that these procedures assume D4 framing and AMI coding.

IMPORTANT: If your test fails to run, Section 1.16 offers additional information about T-Carrier testing.

Table 1-20
End-to-End T1 Test Set-Up

Step	Activity
1.	With the power to the FIREBERD 6000 turned off, insert the DS1/T1/D4/ESF/SLC-96 Interface Module in the rear-panel interface slot.
2.	Press the POWER switch to apply power to the FIREBERD 6000. NOTE: If the FIREBERD 6000 is in Self-Loop mode after power-up, disengage the SELF LOOP switch.

1
2
3
4
5
6
7
8
9
10
11
12
13
14
15
16
17
18
19
20

Table 1-20
End-to-End T1 Test Set-Up (Continued)

Step	Activity
3.	Select a test data pattern using the DATA switch. (Example: QRSS.)
4.	Set the GEN CLK switch to the INTF position to select the network as a timing source. NOTE: Unless there is a source of network timing in the circuit (e.g., a DACS), only one FIREBERD 6000 can use the network as a timing source; as such, the GEN CLK switch on the second FIREBERD should be set to SYNTH.
5.	Using the MENU switch: a. Configure the TI/FTI Interface Module using INTF SETUP. Make these softkey selections. <ol style="list-style-type: none"> 1. DSI/T1 to select the DSI/T1/D4/ESF/SLC-96 Interface Module. 2. RESULT to access the RESULT menu. 3. STD to select standard test results. 4. Δ THRU to access the THRU menu. 5. OFF to select standard interface operation. 6. Δ INPUT to access the INPUT menu. 7. TERM to select the 100-ohm line terminator. 8. Δ MORE ERRINS to access the error insert menu. 9. OFF to turn off error insertion. 10. Δ CODING to access the CODING menu. 11. AMI to select AMI coding. 12. Δ FRAMED to access the FRAMED menu. 13. D4 to select D4 framing. 14. Δ MORE LBO to select the LBO menu. 15. 0dB to select no line buildout. b. Configure the FIREBERD for a TIMED or CONTINUOUS test using the TEST INTERVAL switch (see Appendix C). c. If hard-copy test results are desired, set the print event criteria using PRINT EVENT, then enable the printer control block (located to the left of the POWER switch) by setting the OFF/ON switch to the ON position. (See Appendix D for a sample print event set-up for a T1 test.)
6.	Using the appropriate cables, connect the FIREBERD 6000 to the equipment under test.
7.	Check that the SYNC LED located at the upper right corner of the FIREBERD 6000 is illuminated. RESULT: The FIREBERD has achieved pattern synchronization and is gathering test results. (Section 1.15 lists all T-Carrier test results.)
Legend: Δ = Press the UP ARROW key MORE = Press the MORE key	

1.13.3 In-Service Monitoring

Figure 1-17 depicts one-half of a typical multi-office inter/intra-LATA T1 circuit. In-service monitoring can be performed at locations 1-5.

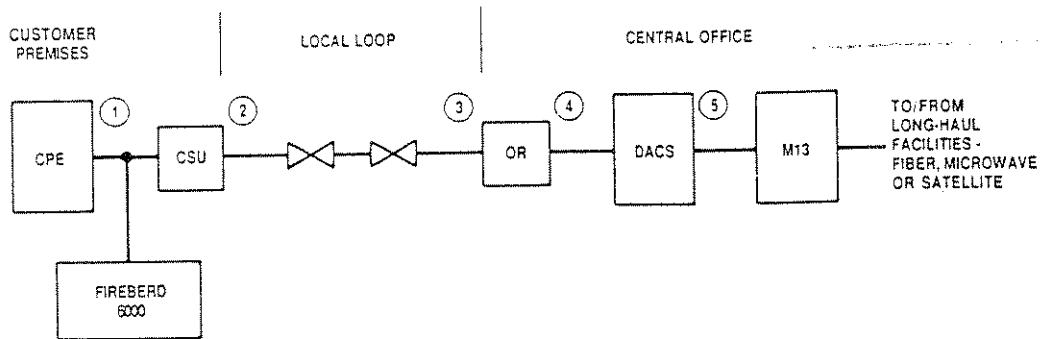


Figure 1-17
In-Service Monitoring

Table 1-21 shows how the FIREBERD 6000 can be set up for in-service monitoring. Please note that these procedures assume D4 framing and that the circuit is being monitored at a DSX patch bay.

IMPORTANT: If your test fails to run, Section 1.16 offers additional information about T-Carrier testing.

Table 1-21
In-Service Monitoring Set-Up

Step	Activity
1.	With the power to the FIREBERD 6000 turned off, insert the DS1/T1/D4/ESF/SLC-96 Interface Module in the rear-panel interface slot.
2.	Press the POWER switch to apply power to the FIREBERD 6000. NOTE: If the FIREBERD 6000 is in Self-Loop mode after power-up, disengage the SELF LOOP switch.
3.	Using the MENU switch: a. Configure the T1/FT1 Interface Module using INTF SETUP. Make these softkey selections.

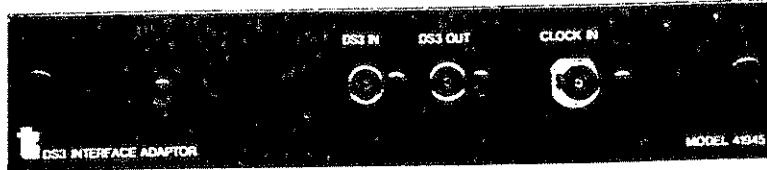


Table 1-21
In-Service Monitoring Set-Up

Step	Activity
3. (Cont.)	<ol style="list-style-type: none"> 1. DS1/T1 to select the DS1/T1/D4/ESF/SLC-96 Interface Module. 2. RESULT to access the RESULT menu. 3. LIVE to select standard test results. 4. Δ INPUT to access the INPUT menu. 5. DSXMON to receive signals from the DSX monitor. 6. Δ MORE ERRINS to access the error insert menu. 7. OFF to turn off error insertion. 8. Δ FRAMED to access the FRAMED menu. 9. D4 to select D4 framing. <p>b. Configure the FIREBERD for a TIMED or CONTINUOUS test using the TEST INTERVAL switch (see Appendix C).</p> <p>c. If hard-copy test results are desired, set the print event criteria using PRINT EVENT, then enable the printer control block (located to the left of the POWER switch) by setting the OFF/ON switch to the ON position. (See Appendix D for a sample print event set-up for a T1 test.)</p>
4.	Using the appropriate cables, connect the FIREBERD 6000's receiver to the DSX-MON jack at the DSX patch bay.
5.	Check that the SYNC LED located at the upper right corner of the FIREBERD 6000 is illuminated.
<p>RESULT: The FIREBERD is monitoring live data. (Section 1.15 lists all T-Carrier test results.)</p>	
<p>Legend: Δ = Press the UP ARROW key MORE = Press the MORE key</p>	

1
2
3
4
5
6
7
8
9
10
11
12
13
14
15
16
17
18
19
20
21
22
23
24
25
26
27
28
29
30
31
32
33
34
35
36
37
38
39
40
41
42
43
44
45
46
47
48
49
50
51
52
53
54
55
56
57
58
59
60
61
62
63
64
65
66
67
68
69
70
71
72
73
74
75
76
77
78
79
80
81
82
83
84
85
86
87
88
89
90
91
92
93
94
95
96
97
98
99
100

1.14 DS3 INTERFACE MODULE



The DS3 Data Interface Module meets ANSI Specification T1.102 Bell Publication CB119, and CCITT 44.736 Mbps Recommendations (applicable sections of G.703).

PATTERNS:	Fixed: 1111, 1100, 1010, 3-to-24 bit programmable Pseudorandom: 2 ¹⁵ -1, 2 ²⁰ -1, 2 ²³ -1
GEN CLK SOURCE:	INTF, SYNTH, and BNC.
DATA RATES:	44.736 Mb/s.
TIMING MODES:	SYNC only. (Switch is disabled.)
FRONT PANEL CONTROL?	Yes.
CABLES/CONNECTORS:	440A to BNC adaptor plug 358 to BNC adaptor plug 440A to 440A cable (10') 440A to 440A cable (1') 440A to 358 adaptor cable (10')

1.14.1 In-Service Monitoring at a DSX-3 Patch Bay

To perform in-service monitoring at a DSX-3 Patch Bay, follow the procedures described in Table 1-22.

1
2
3
4
5
6
7
8
9
10
11
12
13
14
15
16
17
18
19
20
21
22
23
24
25

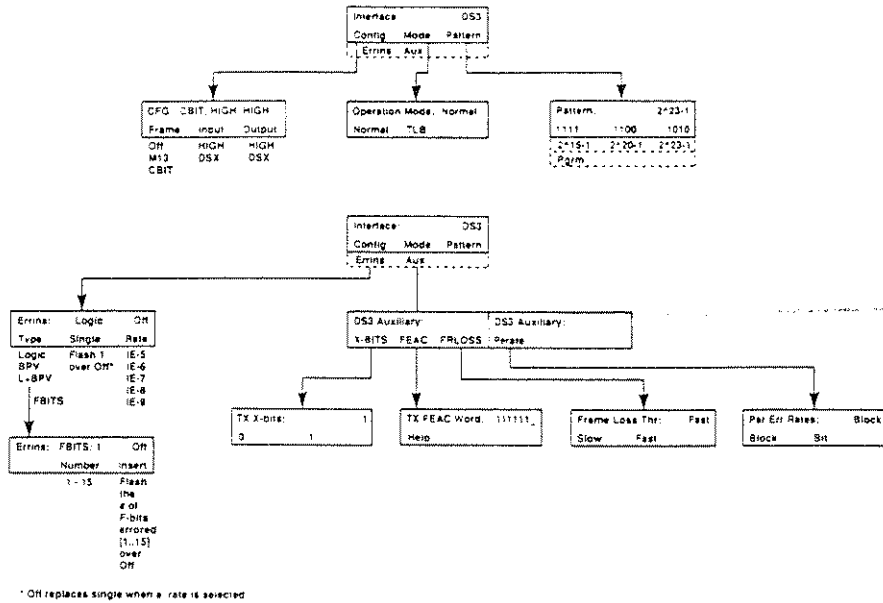


Figure 1-18
DS3 Interface Module Menu Tree

Table 1-22
DS3 In-Service Monitoring Set-Up Procedure

Step	Activity
1.	With the power to the FIREBERD 6000 turned off, insert the DS3 Interface Module in the rear-panel interface slot.
2.	Press the POWER switch to apply power to the FIREBERD 6000. NOTE: If the FIREBERD 6000 is in Self-Loop mode after power-up, press the SELF LOOP switch to extinguish the LED inside the switch.
3.	Using the MENU switch: a. Configure the DS3 Interface Module using INTF SETUP. Make these selections using the softkeys underneath the MENU display: 1. DS3 to select the DS3 Interface Module. 2. CONFIG to access the configuration menu. 3. FRAME to select framing (OFF, M13, or CBIT). 4. INPUT to select DSX input gain and equalization.
Legend: Δ = Press the UP ARROW key MORE = Press the MORE key	

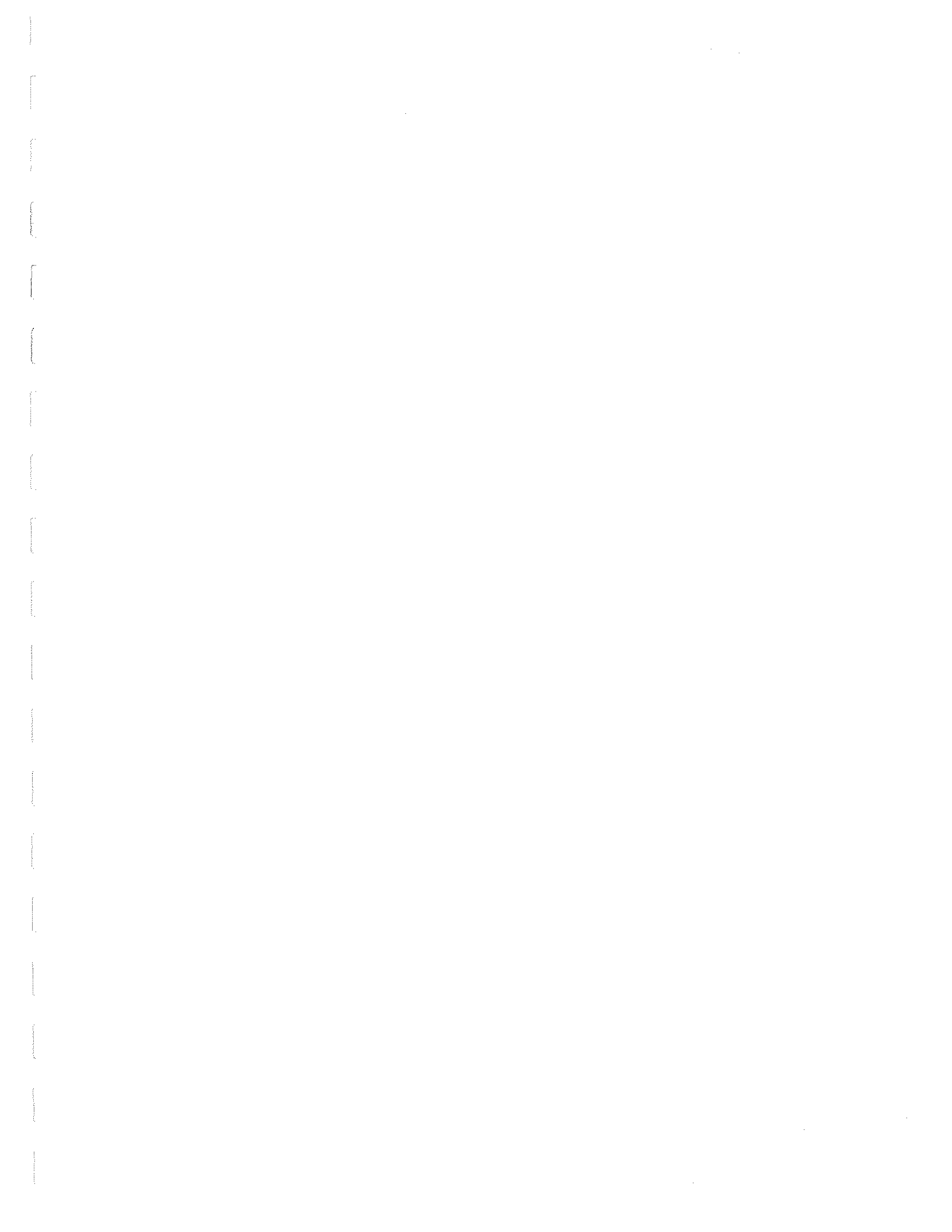


Table 1-22
DS3 In-Service Monitoring Set-Up Procedure (Continued)

Step	Activity
3. (Cont.)	5. Δ MODE to enter the mode menu. 6. NORMAL to select normal mode of operation. b. Configure the FIREBERD for a TIMED or CONTINUOUS test using the TEST INTERVAL switch (see Appendix C). c. If hard-copy test results are desired, set the print event criteria using PRINT EVENT, then enable the printer control block (located to the left of the POWER switch) by setting the OFF/ON switch to the ON position.
4.	Connect a cable from the DS3 IN jack on the DS3 Interface Module to the MONITOR jack on the DSX patch bay.
5.	Press the FIREBERD's RESTART switch to clear all results counters.
6.	Verify that the FRM SYNC LED (below the SYNC LOST LED on the FIREBERD's front panel) is illuminated.
	RESULT: The FIREBERD is monitoring live data. (Section 1.15 lists all T-Carrier test results.)

1.14.2 DS3 Far-End Loopback Test

To set up the FIREBERD for a far-end loopback test, follow the procedures described in Table 1-23.

Table 1-23
DS3 Far-End Loopback Test Set-Up

Step	Activity
1.	With the power to the FIREBERD 6000 turned off, insert the DS3 Interface Module in the rear-panel interface slot.
2.	Press the POWER switch to apply power to the FIREBERD 6000. NOTE: If the FIREBERD 6000 is in Self-Loop mode after power-up, press the SELF LOOP switch to extinguish the LED inside the switch.
3.	Set the GEN CLK switch to the SYNTH position to derive the transmit clock from the interface's internal crystal.
4.	Using the MENU switch: a. Configure the DS3 Interface Module using INTF SETUP. Make these selections using the softkeys underneath the MENU display:



Table 1-23
DS3 Far-End Loopback Test Set-Up (Continued)

Step	Activity
4. (Cont.)	<ol style="list-style-type: none"> 1. DS3 to select the DS3 Interface Module. 2. CONFIG to access the configuration menu. 3. FRAME to select framing (OFF, M13, or CBIT). 4. INPUT to select DSX input gain and equalization. 5. OUTPUT to select DSX output termination. 6. Δ MODE to enter the mode menu. 7. NORMAL to select normal mode of operation. 8. Δ PATTRN to enter the pattern menu. 9. 2^23-1 to select the 2^23-1 pattern. 10. Δ MORE ALX to enter the auxiliary menu. 11. FEAC to select the Far-End Alarm Control menu. 12. Enter the two six-bit FEAC loop codes to establish far-end loopback. <p>b. Configure the FIREBERD for a TIMED or CONTINUOUS test using the TEST INTERVAL switch (see Appendix C).</p> <p>c. If hard-copy test results are desired, set the print event criteria using PRINT EVENT, then enable the printer control block (located to the left of the POWER switch) by setting the OFF/ON switch to the ON position.</p> <ol style="list-style-type: none"> 5. Connect a cable from the DS3 IN jack on the DS3 Interface Module to the IN jack on the DSX-3 patch bay. Connect another cable from the DS3 OUT jack on the Module to the OUT jack on the DSX-3 patch bay. 6. Set the left half of the ANALYSIS RESULTS switch to the BIT ERR position (in the ERROR category); set the right half of the ANALYSIS RESULTS switch to the RCV FREQ position (in the signal category). 7. Check frame and pattern synchronization by verifying that the FRM SYNC and SYNC LEDs on the FIREBERD's front panel are illuminated, and by reading the pattern slips result in the ERROR category. 8. Press the FIREBERD's RESTART switch to clear all results counters. <p>RESULT: The FIREBERD is gathering test results. (Section 1.15 lists all T-Carrier test results.)</p>
<p>Legend: Δ = Press the UP ARROW key MORE = Press the MORE key</p>	

1.14.3 DS3 Point-To-Point Testing

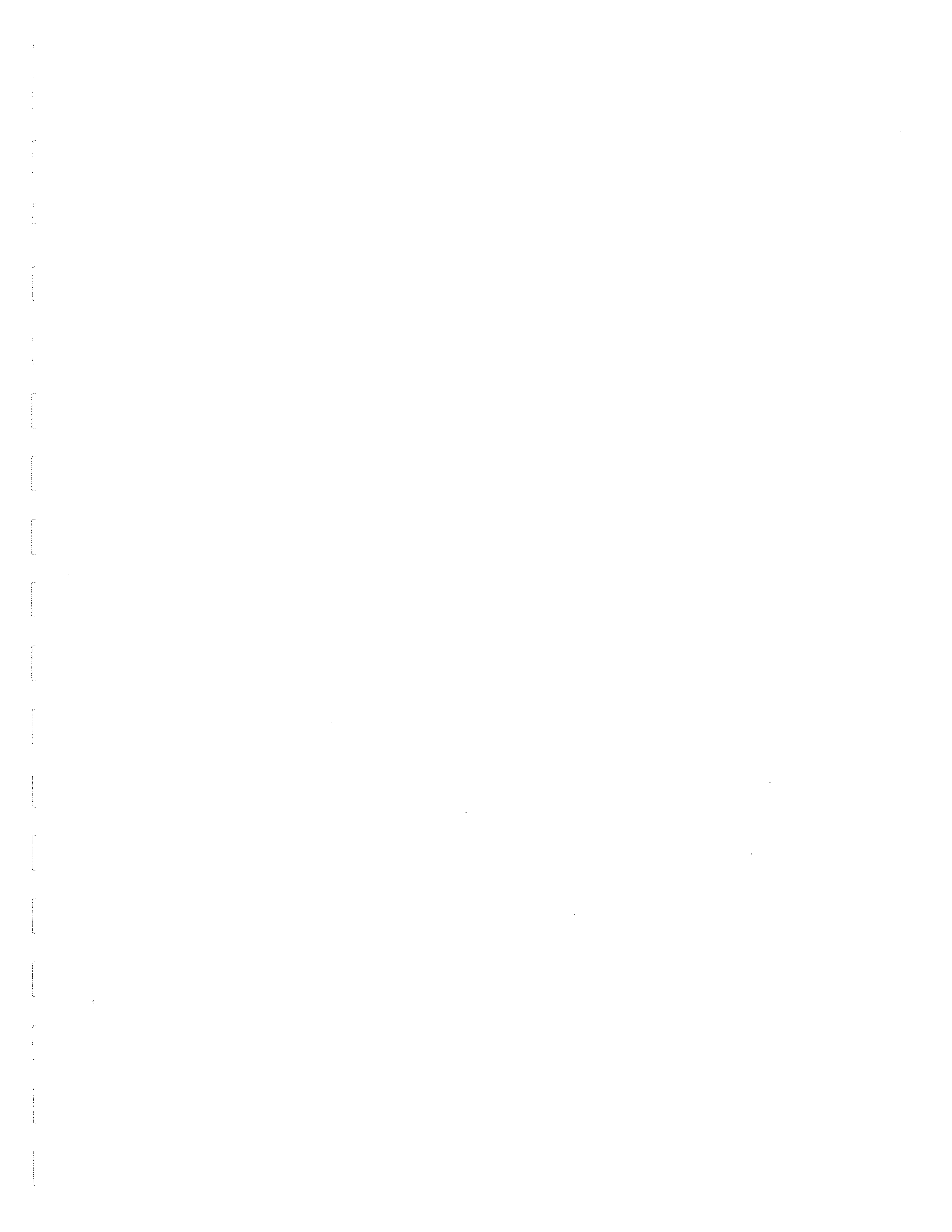
To set up two FIREBERDs for a point-to-point loopback test, follow the procedures described in Table 1-24.

IMPORTANT: These procedures apply to both instruments, *except when setting the GEN CLK switch (see Step 3).*

Table 1-24
Point-To-Point Test Set-Up

Step	Activity
1.	With the power to the FIREBERD 6000 turned off, insert the DS3 Interface Module in the rear-panel interface slot.
2.	Press the POWER switch to apply power to the FIREBERD 6000. NOTE: If the FIREBERD 6000 is in Self-Loop mode after power-up, press the SELF LOOP switch to extinguish the LED inside the switch.
3.	At the near-end DSX-3, set the GEN CLK switch to the INTF position to recover timing from the DS3 network. At the far-end DSX-3, set the GEN CLK switch to the SYNTH position to derive timing from the FIREBERD's internal synthesizer.
4.	Using the MENU switch: a. Configure the DS3 Interface Module using INTFSETUP. Make these selections using the softkeys underneath the MENU display: <ol style="list-style-type: none"> 1. DS3 to select the DS3 Interface Module. 2. CONFIG to access the configuration menu. 3. FRAME to select framing (OFF, M13, or CBIT). 4. INPUT to select DSX input gain and equalization. 5. OUTPUT to select DSX output termination. 6. Δ MODE to enter the mode menu. 7. NORMAL to select normal mode of operation. 8. Δ PATTRN to enter the pattern menu. 9. MORE 2^23-1 to select the 2^23-1 pattern. b. Configure the FIREBERD for a TIMED or CONTINUOUS test using the TEST INTERVAL switch (see Appendix C). c. If hard-copy test results are desired, set the print event criteria using PRINT EVENT, then enable the printer control block (located to the left of the POWER switch) by setting the OFF/ON switch to the ON position.
5.	Connect a cable from the DS3 IN jack on the DS3 Interface Module to the OUT jack on the DSX-3 patch bay. Connect another cable from the DS3 OUT jack on the Module to the IN jack on the DSX-3 patch bay.
6.	Set the left half of the ANALYSIS RESULTS switch to the BIT ERR position (in the ERROR category); set the right half of the ANALYSIS RESULTS switch to the RCV FREQ position (in the signal category).
7.	Check frame and pattern synchronization by verifying that the FRM SYNC and SYNC LEDs on the FIREBERD's front panel are illuminated, and by reading the pattern slips result in the ERROR category.
8.	Press the FIREBERD's RESTART switch to clear all results counters.
<p>Legend: Δ = Press the UP ARROW key MORE = Press the MORE key</p>	





1.15 T-CARRIER TEST RESULTS

1.15.1 DS1 Test Results

Table 1-25 lists the test results that are available when performing T1 testing. Note that some of these results are interface-specific (i.e., apply only to either the DS1/T1 or the DS1/T1/D4/ESF/SLC-96 Interface Module), and that only a subset of these results are available when monitoring in-service.

Table 1-25
DS1 Test Results

Category	Results			
ERROR	AVG BER	BER	BIT ERRS	PAT SLIP
PERFORMANCE	ERR SEC	EFS	%EFS	DEG MIN
	%DEG MIN	SES	%SES	UNA SEC
	AVL SEC	%AVL SEC	SYNL SEC	%SYN SEC
TIME	%PAT SEC	DATE	EA SEC	EF EAS
	ELAP SEC	ERR EAS	PATL SEC	TIME
SIGNAL	%MASK	+LVL V	-LVL V	+LVL dB
	-LVL dB	+WNR	PP WNR	-WNR
	1SEC JTR	15m WNR	24 WNR	B8ZS DETECTED
	DELAY	GEN FREQ	JTR HITS	LVL dBm
	MAX JTR	PPLVL V	RCV BYTE	
T-CARRIER	%VF EAS	AVG BPVR	AVG CRC	AVG FER
	BIT SLIP	BPVs	BPV Rate	CRC ERR
	CRC E Rt	FE Rate	FRA ERR	FRA LOSS
	MAX ZERO	RCV BOM	Rx ABCD	VF EAS
ALARM	1s DEN S	AIS SEC	PAT LOSS	PWR LOSS
	SIG LOSS	XS0 SEC	YEL SEC	

1.15.2 DS3 Test Results

Table 1-26 lists the test results that are available when performing DS3 testing. Note that only a subset of these results are available when monitoring in-service.



Table 1-26
DS3 Test Results

Category	Results			
ERROR	AVG BER	BIT ERRS	BER	PAT SLIP
PERFORMANCE	FEBS A CPE S B	FEBS B CPE S C	FEBS C	CPE S A
TIME	DATE %EF EAS ELAP SEC	ERR EAS SIGL SEC TIME	E A SEC PATL SEC	EF EAS %PAT SEC
SIGNAL	GEN FREQ	RCV FREQ		
T-CARRIER	BPVs BPV %EFS FRA LOSS RX X1:X2 FEBE	AVG BPVR FRA ERR PAR ERR CPAR ERR AVG FEBE	BPV Rate AVG FER AVG PER AVG CPER FEBE Rt	BPV SEC FE RATE PAR E Rt CPE Rt RCV FEAC
ALARMS	PWR LOSS FEOOF	PAT LOSS	SIG LOSS	NEOFF S

1.16 NOTES ON T-CARRIER TESTING

If your test fails to run after completing the set-up procedures for your T-Carrier test, the sections that follow may lead you to the solution. Note that only the most likely potential problem areas are addressed; if your test still fails after exploring these problem areas, call TTC's toll-free number (1-800-638-2049) for technical assistance.

1.16.1 Incorrect Line Build Out

Selecting the correct line build-out value is determined by the distance between your FIREBERD and the nearest line or office repeater. If line build out is set incorrectly, your FIREBERD may signal a yellow alarm condition before your test begins.

To ensure correct setting, check the line build-out value for the CSU that you are testing. If the setting differs from that specified for your test, change the line build out as appropriate for your interface.



1.16.2 Non-Availability of the Selected T1 Timing Source

If the GEN CLK switch is illuminated, and set to the INTF position, be sure that a source of network timing exists for your specific T1 application: the switch illuminates when the FIREBERD cannot receive the clock from the selected timing source.

If the GEN CLK switch is illuminated, do the following:

1. Check cables to make sure they are connected correctly.
2. If the GEN CLK switch is still illuminated, make sure that a network timing source exists for your application.
3. If a network timing source does not exist, use the FIREBERD 6000's frequency synthesizer as the timing source, as follows:
 - a. Set the GEN CLK switch to the SYNTH position.
 - b. Using the MENU switch, set the synthesizer frequency to 1544 using SYNTH FREQ and the appropriate softkeys.

SUGGESTION: Check the GEN FREQ measurement (under the SIGNAL analysis category) to ensure that your current generator clock frequency is 1.544 Mb/s. This confirms the presence and accuracy of a network clock source.

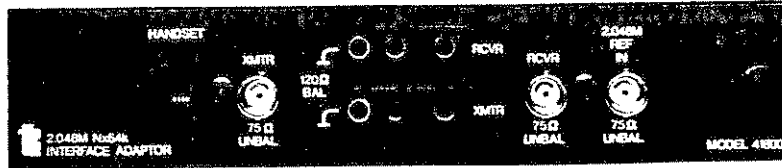
1.16.3 Setting Auxiliary Functions

Sometimes the setting of one of the auxiliary functions may not be appropriate for your specific test. Use Auxiliary Function 99 to reset all of your auxiliary functions to their default states.

CAUTION:

THE USE OF THIS FUNCTION RESETS ALL AUXILIARY FUNCTIONS VALUES.

1.17 2MB/S/NX64K INTERFACE MODULE



The 2Mb/s/Nx64 Interface Module meets CCITT "Blue Book" specifications G.703, G.704, G.732, G.821, G.823, and O.171.

PATTERNS:	All.
GEN CLK SOURCE:	SYNTH. BNC. INTF (Receiver), and INTF (2.084M Reference).
DATA RATES:	56/64 kbps. N x 56/64 kbps (N = 1, ..., 31), 2.048 Mbps framed or unframed.
TIMING MODES:	SYNC only. (Switch is disabled.)
FRONT PANEL CONTROL?	Yes.
CABLES/CONNECTORS:	BNC to BNC cable (2.0 m) Siemens 3-pin connector to Siemens 3-pin connector Siemens 3-pin connector to Bantam Plug cable (2.0 m) BNC (75Ω Unbalanced) connector to Siemens 3-pin connector (120Ω Balanced) adaptor (2.0 m)

1.17.1 Out-of-Service Nx64kbps Testing

Table 1-27 describes how the FIREBERD 6000 can be set up to perform an Nx64kbps out-of-service test using the 2.048M/Nx64k Interface Module. This setup can be used to test any combination of the thirty-one 64Kbps timeslots that comprise the 2 Mbps circuit.



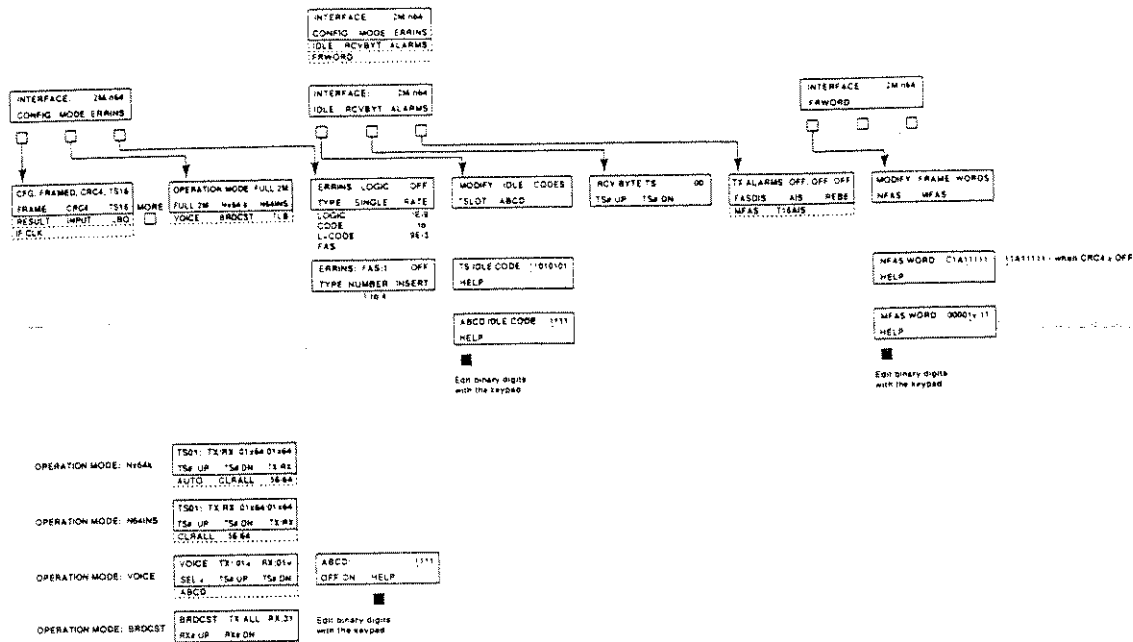


Figure 1-19
2 Mbps-Nx64 kbps Interface Module Menu Tree

Table 1-27
2Mbps/Nx64 Out-of-Service Test Set-Up

Step	Activity
1.	With the power to the FIREBERD 6000 turned off, insert the 2Mbps/Nx64k Interface Module in the rear-panel interface slot.
2.	Press the POWER switch to apply power to the FIREBERD 6000. NOTE: If the FIREBERD 6000 is in Self-Loop mode after power-up, press the SELF LOOP switch to extinguish the LED inside the switch.
3.	Set the GEN CLK switch to the INTF position to derive the transmit clock from the network. (If the network does not provide a clock signal to the customer's equipment, set the GEN CLK switch to SYNTH. If a local external TTL clock is desired, set the GEN CLK switch to BNC.)
4.	Set the DATA switch to 2 ¹⁵ -1.
5.	Using the MENU switch, configure the 2Mbps/Nx64k Interface Module using the INTF SETUP option in the MENU section. Make these selections by pressing the MENU softkeys underneath their display.

1
2
3
4
5
6
7
8
9
10
11
12
13
14
15
16
17
18
19
20
21
22
23
24
25
26
27
28
29
30
31
32
33
34
35
36
37
38
39
40
41
42
43
44
45
46
47
48
49
50
51
52
53
54
55
56
57
58
59
60
61
62
63
64
65
66
67
68
69
70
71
72
73
74
75
76
77
78
79
80
81
82
83
84
85
86
87
88
89
90
91
92
93
94
95
96
97
98
99
100

Table 1-27
2Mbps/Nx64 Out-of-Service Test Set-Up (Continued)

Step	Activity
<p>5. (Cont.)</p>	<p>a. 2M/n64 to select the 2Mbps/Nx64k Interface Module.</p> <p>b. CONFIG to access the configuration menu.</p> <ol style="list-style-type: none"> 1. Set FRAME to FRAMED, and select the appropriate multiframing as it applies to the network being tested - both CRC4 and TS16 may be toggled on and off. 2. MORE Set RESULT to STANDARD. 3. Set INPUT to TERM. 4. Set LBO to 0dB. 5. MORE Set IF CLK is set to RCVR. (If the 2Mbps/Nx64k Interface uses its 2 Mbps Reference input for the Transmit Clock Source, then IF CLK should be set to REF.) <p>c. Δ MODE to access mode settings.</p> <ol style="list-style-type: none"> 1. MODE is set to Nx64k. 2. Select the desired number of active timeslots— timeslots which are provisioned to carry data. Timeslots may be scrolled through using the TS# UP and TS# DN Menu softkeys. Timeslots may be set to transmit (TX), receive (RX), or both: press the TX/RX Menu softkey repeatedly to toggle through the four possible transmit/receive settings for each timeslot. <p>d. $\Delta \Delta$ Set ERRINS to OFF if no stress-testing is to be performed.</p> <p>e. Δ MORE IDLE is used to modify the idle codes. Ordinarily the defaults built into the 2Mbps/Nx64k Interface Module are appropriate, and do not need to be changed. To change the idle codes to match those used by your network, do the following:</p> <ol style="list-style-type: none"> 1. Select the IDLE softkey. 2. Select the TSLOT or ABCD Idle Codes, as appropriate. 3. Key in the appropriate binary digits using the 1 and 0 keys on the MENU keypad. 4. Press the ENTER key on the MENU keypad. <p>6. Set the ANALYSIS MODE switch to the CONTINUOUS position.</p> <p>7. Connect the 2 Mbps IN jack on the Network Termination Unit (NTU) to the Transmit (TX) jack on the 2Mbps/Nx64k Interface Module. Connect the OUT jack on the NTU to the Receiver (RX) jack on the 2Mbps/Nx64k Interface Module.</p> <p>8. Press the FIREBERD's RESTART switch to clear all results counters.</p> <p>9. Verify that the FRM SYNC LED (below the SYNC LOST LED on the FIREBERD's front panel) is illuminated.</p>
<p>Legend: Δ = Press the UP ARROW key MORE = Press the MORE key</p>	

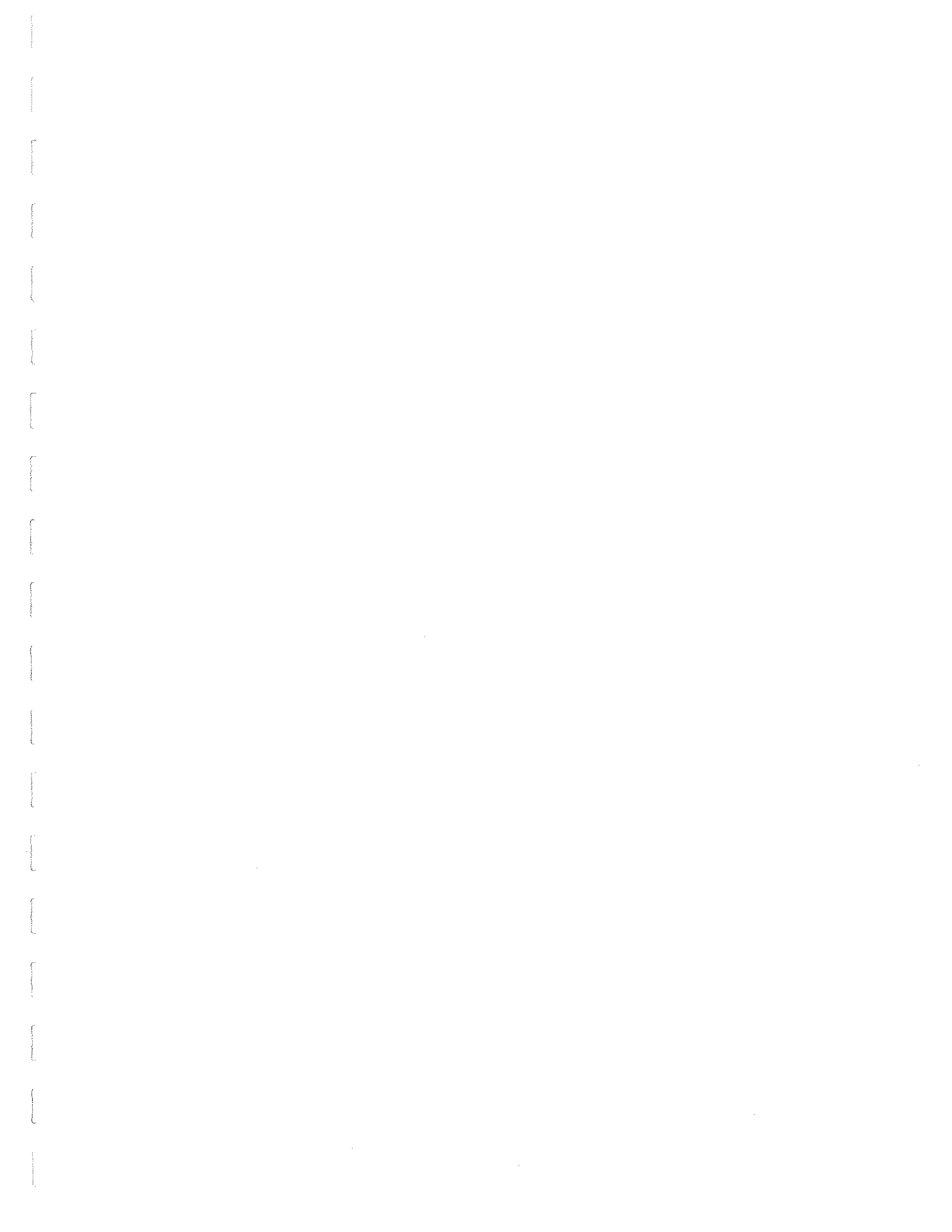


Table 1-27
2Mbps/Nx64 Out-of-Service Test Set-Up (Continued)

Step	Activity
10.	Verify that the SYNC LED (above the SYNC LOST LED on the FIREBERD's front panel) is illuminated; this ensures pattern synchronization.

1.17.2 Basic In-Service Live Data Monitoring

Table 1-28 describes how the FIREBERD 6000 can be set up to perform in-service monitoring a 2 Mbps circuit using a 2.048M/Nx64k Interface Module.

Table 1-28
2Mbps/Nx64 In-Service Test Set-Up

Step	Activity
1.	With the power to the FIREBERD 6000 turned off, insert the 2Mbps/Nx64k Interface Module in the rear-panel interface slot.
2.	Press the POWER switch to apply power to the FIREBERD 6000. NOTE: If the FIREBERD 6000 is in Self-Loop mode after power-up, press the SELF LOOP switch to extinguish the LED inside the switch.
3.	Using the MENU switch, configure the 2Mbps/Nx64k Interface Module using the INTF SETUP option in the MENU section. Make these selections by pressing the MENU softkeys underneath their display. <ul style="list-style-type: none"> a. 2M/n64 to select the 2Mbps/Nx64k Interface Module. b. CONFIG to access the configuration menu. <ul style="list-style-type: none"> 1. ... Set FRAME to FRAMED or UNFRAMED, as appropriate for your network. If FRAME is selected, select multiframing as it applies to the network under test. 2. MORE Set RESULT to LIVE. 3. Set INPUT to MON (for a resistively isolated monitor jack).
4.	Press the ENTER key on the MENU keypad.
5.	Set the ANALYSIS MODE switch to the CONTINUOUS position.
<p>Legend: Δ = Press the UP ARROW key MORE = Press the MORE key</p>	



Table 1-28
2Mbps/Nx64 In-Service Test Set-Up (Continued)

Step	Activity
6.	Press the FIREBERD's RESTART switch to clear all results counters.
7.	Verify that the FRM SYNC LED (below the SYNC LOST LED on the FIREBERD's front panel) is illuminated.

1.18 2 MBPS/NX64K TEST RESULTS

1.18.1 Out-of-Service Test Results

Table 1-29 below lists all the test results available on the 2Mbps/Nx64k Interface Module during out-of-service testing.

Table 1-29
2Mbps/Nx64k Out-of-Service Test Results

Category	Results			
ERROR	AVG BER PAT SLIP (63, 511, 2047, 215-1, 220-1, 223-1, QRSS patterns only)	BIT ERRS	BER	
PERFORMANCE	UNA SEC BER-SES DEG MIN	AVL SEC GERR SEC %DEG MIN	%AVL SEC G EFS SES	ERR-SES G %EFS %SES
TIME	DATE ELAP SEC	ERR EAS PATL SEC	E A SEC %PAT SEC	EF EAS TIME
SIGNAL	DELAY +LVL dB PP WNDR	GEN FREQ -LVL dB 15m WNDR	RCV FREQ +WNDR 24h WNDR	RCV BYTE -WNDR
T-CARRIER	FAS ERR AVG MFAS REBE RT	AVG FAS MFS E Rt AVG CRC	FAS E Rt REBE CRC E Rt	MFAS ERR AVG REBE FRA LOSS

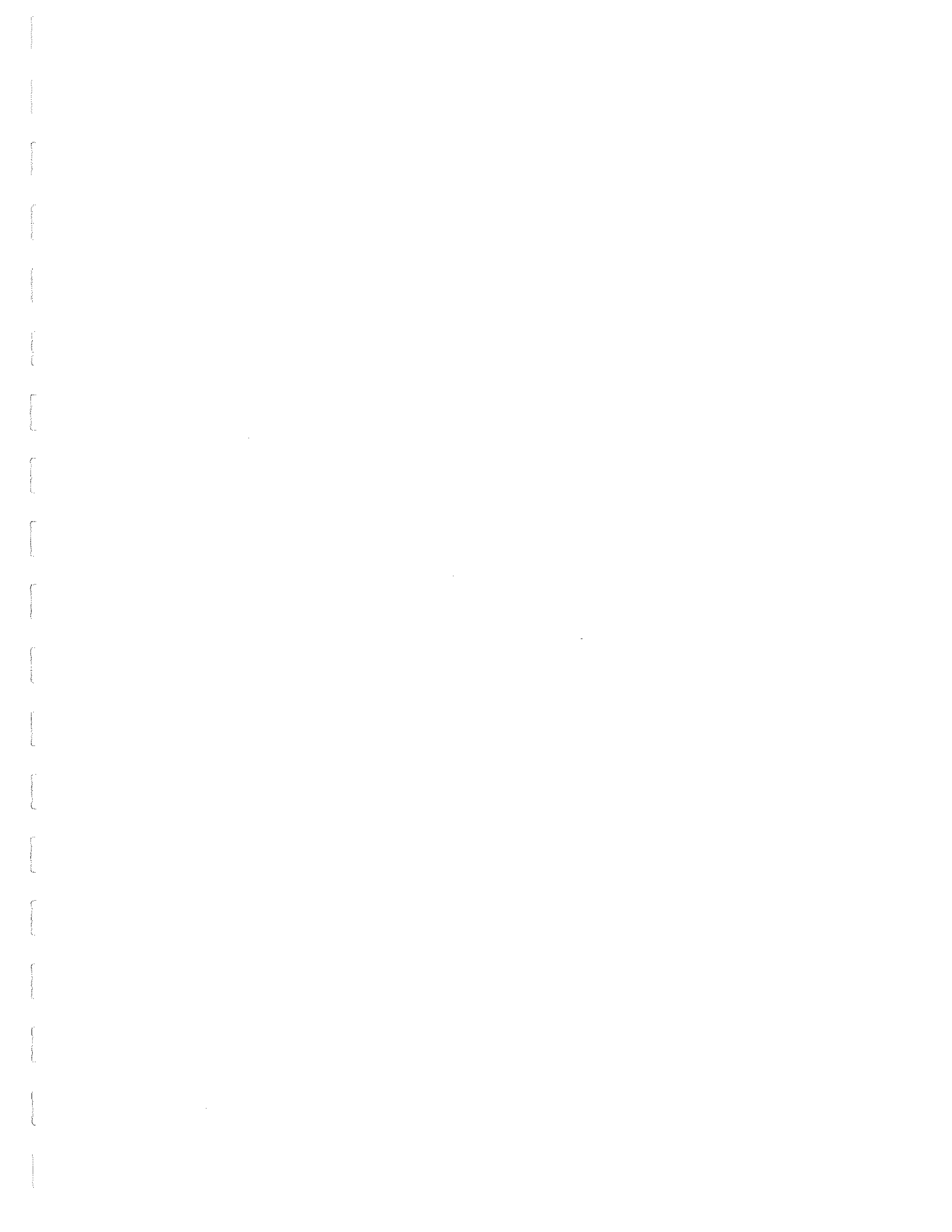


Table 1-29
2Mbps/Nx64k Out-of-Service Test Results (Continued)

Category	Results			
T-CARRIER	RCV FAS CODE ERR	RCV NFAS AVG CER	RCV MFAS CER	BIT SLIP CRC ERR
ALARMS	MFAS SEC AIS SEC FAS SEC	PWR LOSS T16-AIS S	PAT LOSS	SIG LOSS

1.18.2 In-Service Test Results

Table 1-30 below lists the test results available on the 2Mbps/Nx64k Interface Module during in-service testing.

Table 1-30
2Mbps/Nx64k In-Service Test Results

Category	Results			
ERROR	No error results returned			
PERFORMANCE	UNA SEC G VFS %DEG MIN	AVLSEC %SVS	%AVL SEC G %VFS	SVS DEG MIN
TIME	DATE ELAP SEC	E A SEC TIME	SIGL SEC	% ACT SEC
SIGNAL	PP WNDR +LVL dB 15m WNDR	GEN FREQ -LVL dB 24h WNDR	RCV FREQ +WNDR	RCV BYTE -WNDR

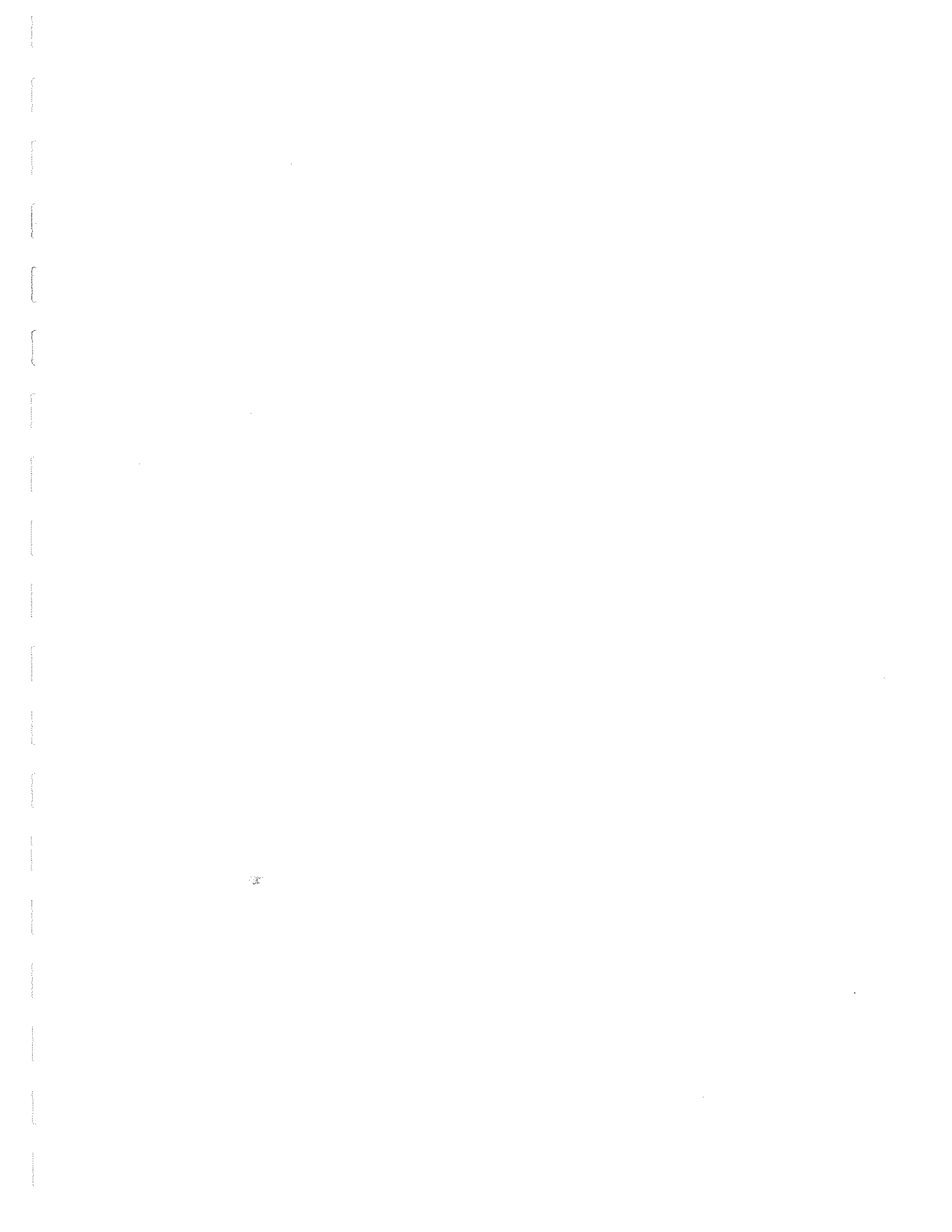


Table 1-30
2Mbps/Nx64k In-Service Test Results (Continued)

Category	Results			
T-CARRIER	VF EAS	%VF EAS	FRA LOSS	FAS ERROR
	AVG FAS	FAS E R t	RCV FAS	RCV NFAS
	BIT SLIP	CODE ERR	AVG CER	CER
	MFAS ERR	RCV MFAS	CRC ERROR	REBES
	MFM E R t	AVG MFAS	CRC E R t	AVG CRC
	REBE RT	AVG REBE		
ALARMS	PWR LOSS	SIG LOSS	AIS SEC	
		FAS SEC	MFAS S	T16AIS S

1.19 NOTES ON G.704 2048 KB/S TESTING

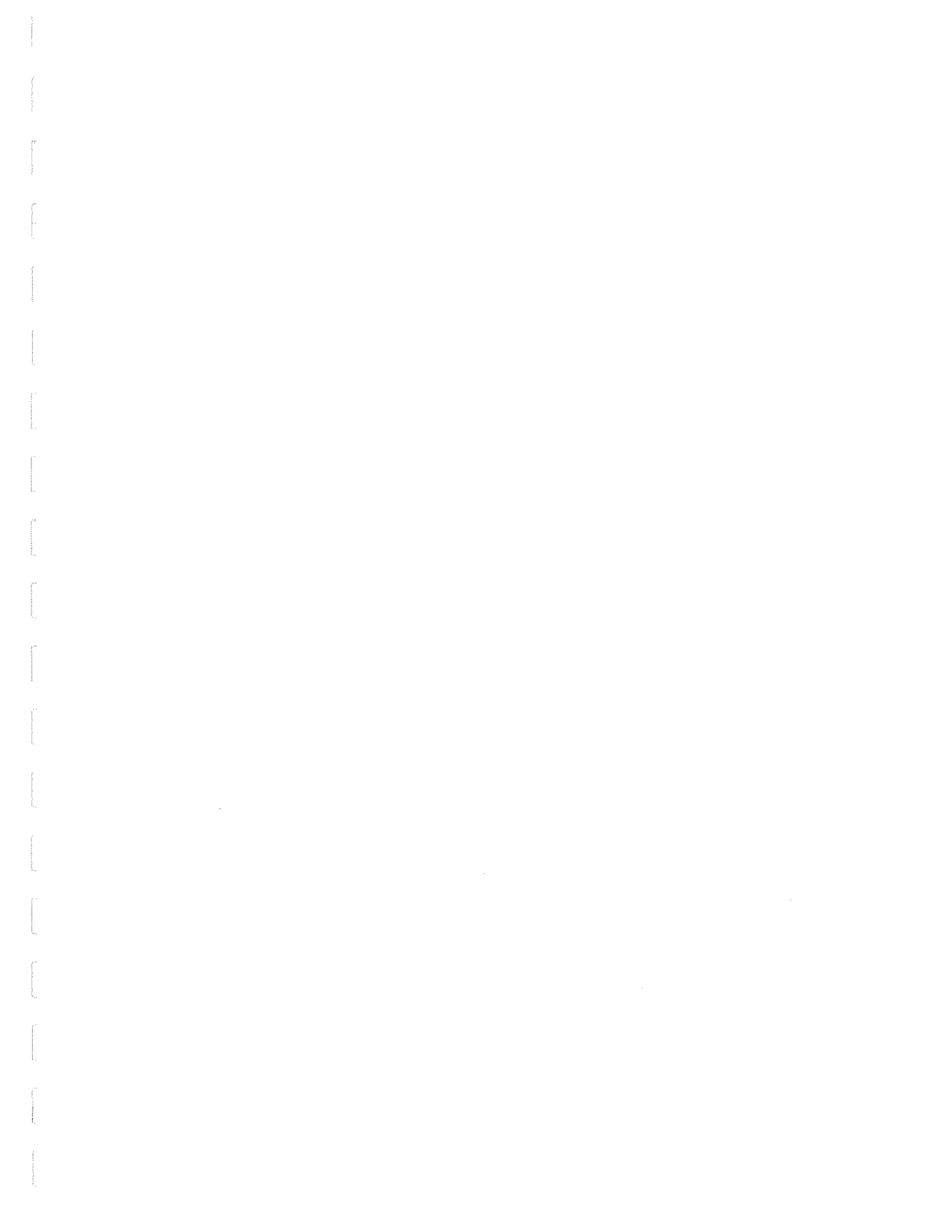
If your test fails to run after completing the set-up procedures for your G.703 or G.704 test, the sections that follow may lead you to the solution. Note that only the most likely potential problem areas are addressed; if your test still fails after exploring these problem areas, call TTC's toll-free number (1-800-638-2049) for technical assistance.

1.19.1 Non-Availability of the Selected Timing Source

If the GEN CLK switch is illuminated, and set to the INTF position, be sure that a source of network timing exists for your specific application: the switch illuminates when the FIREBERD cannot receive the clock from the selected timing source.

If the GEN CLK switch is illuminated, do the following:

1. Check cables to make sure they are connected correctly.
2. If the GEN CLK switch is still illuminated, make sure that a network timing source exists for your application.
3. If a network timing source does not exist, use the FIREBERD 6000's frequency synthesizer as the timing source, as follows:
 - a. Set the GEN CLK switch to the SYNTH position.
 - b. Using the MENU switch, set the synthesizer frequency to 2048 using SYNTH FREQ and the appropriate softkeys.



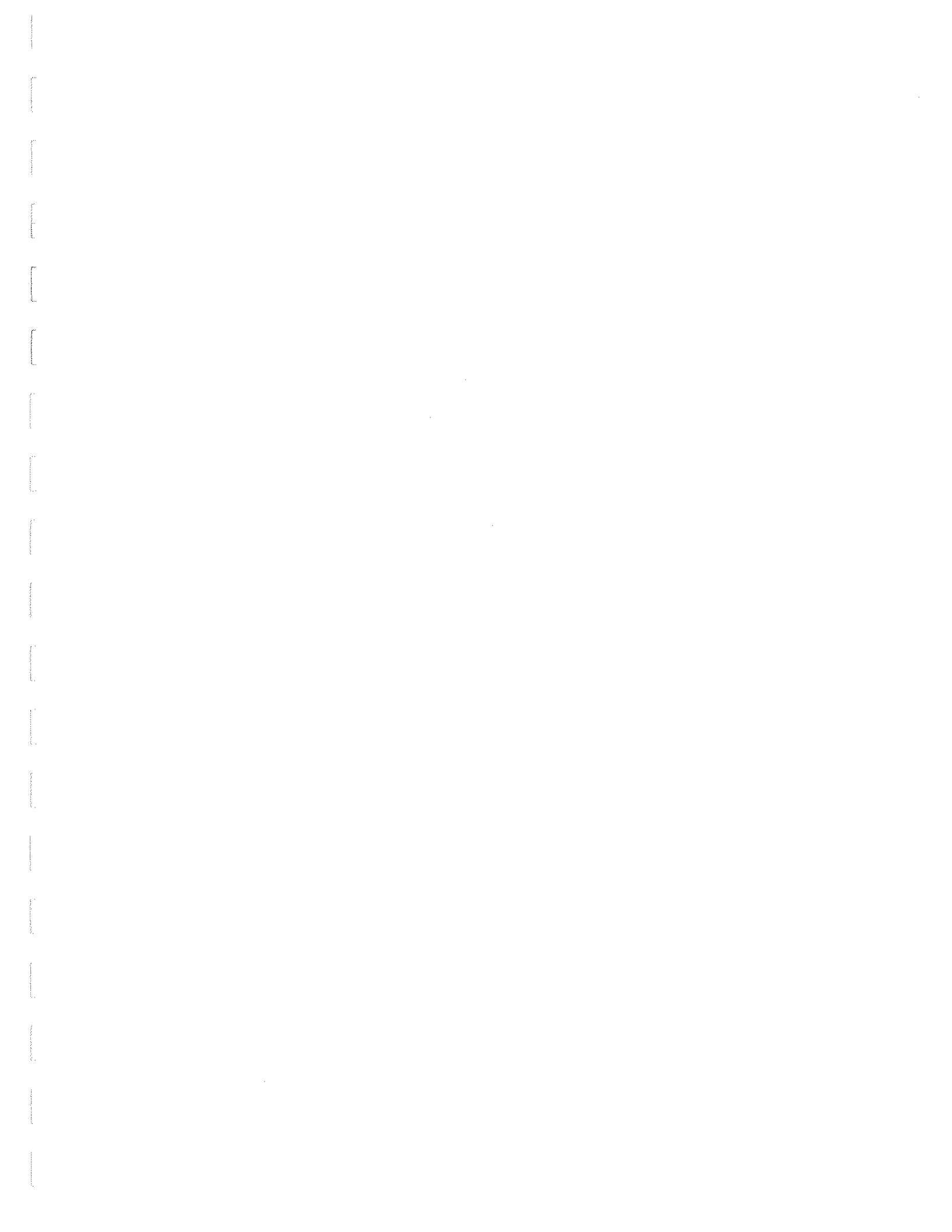
SUGGESTION: Check the GEN FREQ measurement (under the SIGNAL analysis category) to ensure that your current generator clock frequency is 2.048 Mbps. This confirms the presence and accuracy of a network clock source.

1.19.2 Setting Auxiliary Functions

Sometimes the setting of one of the auxiliary functions may not be appropriate for your specific test. Use Auxiliary Function 99 to reset all of your auxiliary functions to their default states.

CAUTION:

THE USE OF THIS FUNCTION RESETS ALL AUXILIARY FUNCTIONS VALUES.



SECTION 2 CONFIGURING THE FIREBERD 6000 FOR PRINTER OPERATION

2.1 SECTION SUMMARY

This section describes how the FIREBERD 6000 Communications Analyzer can be configured with both the PR-40A and PR-2000 printers.

The PR-40A is a thermal printer that provides 40-column printouts, as well as bit-mapped histograms and jitter graphs. Although any serial printer can be used, the PR-40A is highly recommended for its ease of use and its compatibility with the FIREBERD 6000.

The PR-2000 is a miniature alphanumeric printer that uses non-impact thermal printing for low cost display and instrumentation applications. The PR-2000 features 20-column printing in self-contained, rack-mountable casing, including complete control and interface electronics with AC power supply.

2.2 CONFIGURING THE FIREBERD WITH THE PR-40A PRINTER

The table immediately following shows how the FIREBERD 6000 can be configured to operate with the PR-40 printer.

Table 2-1
Configuring the FIREBERD 6000 With The PR-40A Printer

Step	Activity
1.	Using the MENU switch, select the AUXILIARY function.
2.	Using the MENU keypad, type the number 38 and press the ENTER key. RESULT: The softkey labels BAUD, DATA, and PARITY are displayed.
3.	Press the BAUD softkey. RESULT: Several baud rates appear in the MENU display.
4.	MORE Press the 2400 softkey to select the 2400 baud rate.
5.	Δ Press the DATA softkey. RESULT: The DATA menu selections appear in the MENU display.
Legend: Δ = Press the UP ARROW key MORE = Press the MORE key	



Table 2-1
Configuring the FIREBERD 6000 With The PR-40A Printer (Continued)

Step	Activity
6.	Press the 8 softkey to select 8 data bits.
7.	<p>MORE Press the PARITY softkey.</p> <p>RESULT: The PARITY menu selections appear in the display.</p>
8.	Press the NONE softkey to select no parity.
9.	<p>Δ Δ Using the MENU keypad, type the number 37 and press the ENTER key.</p> <p>RESULT: The COLUMN, TERM, and MODE softkeys appear in the display.</p>
10.	<p>Press the TERM softkey.</p> <p>RESULT: The TERM menu selections appear in the display.</p>
11.	Press the CR LF softkey to terminate a line on a carriage return/line feed pair.
12.	<p>Δ Press the MODE softkey.</p> <p>RESULT: The selections associated with the MODE menu appear in the display.</p>
13.	Press the FAST softkey for standard PR-40A operation and press the ENTER key.
14.	<p>Δ Press the COLUMN softkey.</p> <p>RESULT: Several column widths appear in the in the display.</p>
15.	Press the 40 softkey to select the 40-character column width.
16.	<p>Press the OFF/ON switch of the PRINTER control block of the FIREBERD 6000.</p> <p>RESULT: The green LED within the ON/OFF switch is illuminated.</p>
<p>Legend: Δ = Press the UP ARROW key MORE = Press the MORE key</p>	

The FIREBERD 6000 is now configured for operation with the PR-40A. Pressing the CONTROLS switch of the PRINTER control block generates a printout of the current switch settings.

2.3 CONFIGURING THE FIREBERD WITH THE PR-2000 PRINTER

The table immediately following shows how the FIREBERD 6000 can be configured to operate with the PR-2000 printer.

Table 2-2
Configuring the FIREBERD 6000 With The PR-2000 Printer

Step	Activity
1.	Using the MENU switch, select the AUXILIARY function.
2.	Using the MENU keypad, type the number 38 and press the ENTER key. RESULT: The softkey labels BAUD, DATA, and PARITY are displayed.
3.	Press the BAUD softkey. RESULT: Several baud rates appear in the MENU display.
4.	MORE Press the 2400 softkey to select the 2400 baud rate.
5.	Δ Press the DATA softkey. RESULT: The DATA menu selections appear in the MENU display.
6.	Press the 7 softkey to select 7 data bits.
7.	MORE Press the PARITY softkey. RESULT: The PARITY menu selections appear in the display.
8.	Press the EVEN softkey to select even parity.
9.	Δ Δ Using the MENU keypad, type the number 37 and press the ENTER key. RESULT: The COLUMN, TERM, and MODE softkeys appear in the display.
10.	Press the TERM softkey. RESULT: The TERM menu selections appear in the display.
11.	Press the CRLF softkey to terminate a line on a carriage return/ line feed pair.
12.	Δ Press the MODE softkey. RESULT: The selections associated with the MODE menu appear in the display.
Legend: Δ = Press the UP ARROW key MORE = Press the MORE key	



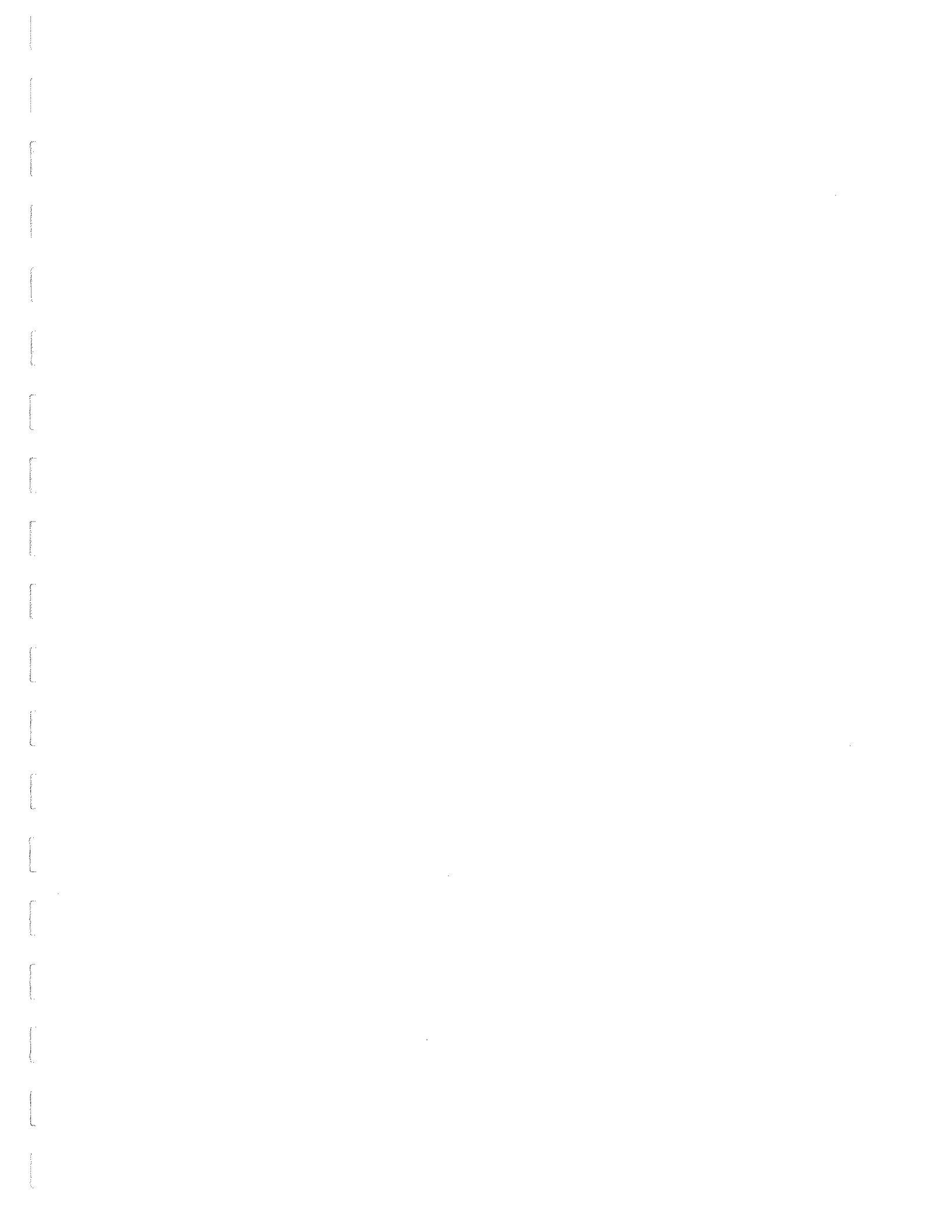
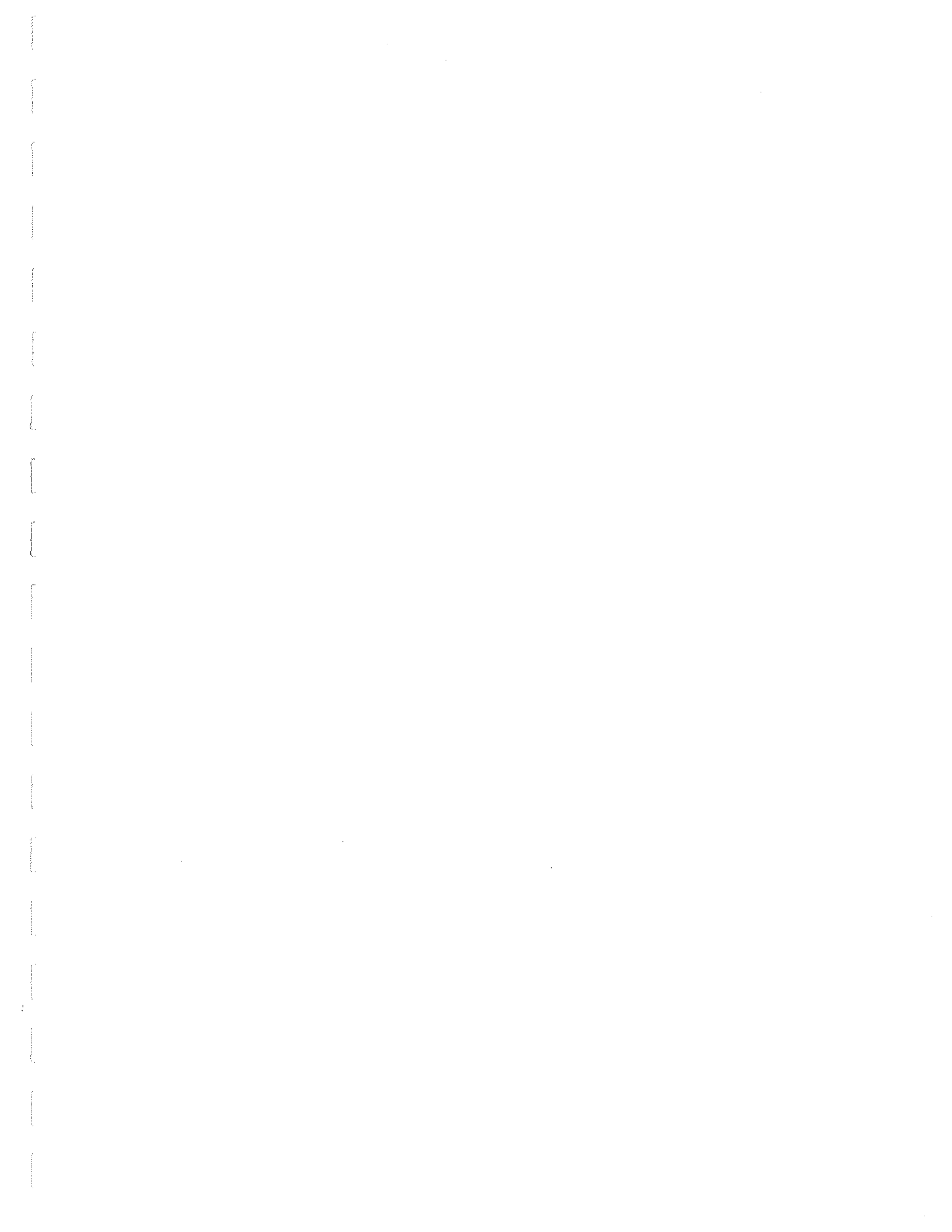


Table 2-2
Configuring the FIREBERD 6000 With The PR-2000 Printer (Continued)

Step	Activity
13.	Press the SLOW softkey for standard PR-2000 operation and press the ENTER key.
14.	Δ Press the COLUMN softkey. RESULT: Several column widths appear in the in the display.
15.	Press the 20 softkey to select the 20-character column width.
16.	Press the OFF/ON switch of the PRINTER control block of the FIREBERD 6000. RESULT: The green LED within the ON/OFF switch is illuminated.
Legend: Δ = Press the UP ARROW key MORE = Press the MORE key	

The FIREBERD 6000 is now configured for operation with the PR-2000. Pressing the CONTROLS switch of the PRINTER control block generates a printout of the current switch settings.



APPENDIX A AUXILIARY FUNCTIONS

Table A-1
Status-Select Auxiliary Functions

Function	Number	Name	Description
Generator Clock Polarity	01	GEN CLK POL	NORMAL - Generates clock data phasing per interface standard. INVERT - Clock data phasing is the inverse of the interface standard.
Receiver Clock Polarity	02	RCVR CLK POL	AUTO - Receiver clock data phasing is automatically detected, corrected, and maintained while error analysis is in progress. NORMAL - Clock data phasing is per interface standard. INVERT - Clock data phasing is the inverse of the interface standard.
Receiver Action On Synchronization Loss	03	ACT SYN LOSS	CLEAR - Clears all results counters and restarts test when synchronization is reacquired. HALT - Freezes all results for duration of synchronization loss. Test continues when synchronization is reacquired. CONT - Continue to accumulate error analysis results while the receiver attempts to resynchronize. (Valid in SYNC and RECOVD timing modes only.)
Single Transmit	04	SINGLE TRANS	OFF - Transmits data continuously. ON - Transmits only one pattern or message each time the RESTART switch is pressed. This auxiliary function is disabled in self-loop mode, and disabled when Long User Patterns are selected.
Generator Data Inverter	06	GEN DATA INV	OFF - Transmitted data not inverted. ON - Transmitted data inverted.
Receiver Clock Select (DCE only)	07	RCVR CLK SEL	AUTO - ST (a DCE output) is automatically selected if TT (a DCE input) is not present in the interface.

A

Vertical text on the left margin, possibly a page number or header.

Table A-1
Status-Select Auxiliary Functions (Continued)

Function	Number	Name	Description
Receiver Clock Select (Continued)	07	RCVR CLK SEL	TT - TT selected. ST - ST selected.
Out-of-Band Flow Control	08	OUT-BAND FLOW	OFF - Data transmission occurs regardless of signaling lead status. ON - Data transmission is conditioned upon the receipt of one or more of the following signaling leads: TR (DTR), DM (DSR), RS (RTS), CS (CTS), and RR (RLSD). CS is the default. This auxiliary function is disabled in self-loop mode.
In-Band Flow Control	09	IN-BAND FLOW	OFF - FIREBERD does not respond to XON and XOFF characters in the data received. (Asynchronous transmission is not affected.) ON - FIREBERD scans the incoming data for XON and XOFF characters and responds accordingly. XOFF halts the transmission of data and XON resumes the transmission of data. The XON defaults to 11H. The XOFF default is 13H. This auxiliary function applies to asynchronous USER and FOX messages only.
Sync Loss Threshold	10	SYNC LOSS THR	Thresholds for SYNC and RECOVD timing modes are: LOW - Declare sync loss when 100 bit errors are counted in less than 1000 bits. MED - Declare sync loss when 250 bit errors are counted in less than 1000 bits. HIGH - Declare sync loss when 20,000 bit errors are counted in less than 100,000 bits. The settings for ASYNC timing mode are: LOW and MED - Declare sync loss when 30 character errors are counted in less than 60 received characters. HIGH - Declare sync loss when 20,000 bit errors are counted in less than 100,000 bits.

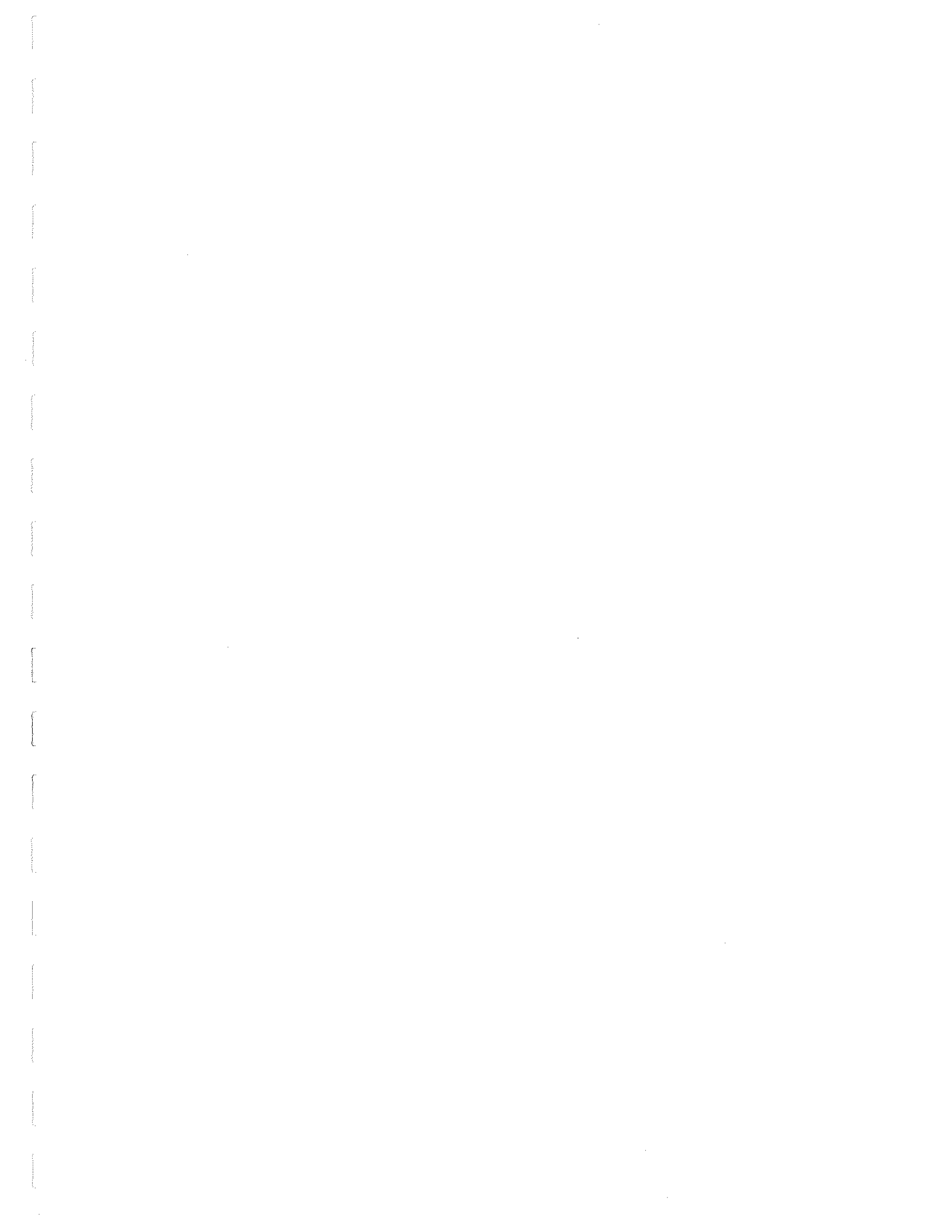


Table A-2
Non-Status-Select Auxiliary Functions

Function	Number	Name	Description
I/O Driver Select	11	IO DRIVER SEL	<p>SELECT - Sets the FIREBERD for both printing and remote control in any combination of the following:</p> <p>Remote Control: 232, 488, None.</p> <p>Printing: 232, 488, Remote, None.</p>
Block Length	30	BLK LEN	Select the block length. The allowable range is 100 - 1,000,000 bits.
Signal Delay	31	DELAY	<p>Set up the FIREBERD for signal delay timing. The start timing and stop timing signals and edges are selected with this function.</p> <p>NOTE: The start and stop parameters that reference signaling leads are only valid for interfaces that use these signals.</p>
Program Common Frequencies	32	COMMON FREQUENCIES	Program the most commonly used frequencies as softkey settings for the SYNTH FREQ function of the MENU switch.
Programmable Pattern	33	PRGM PATTERN	<p>Program and edit a 3- to 24-bit data pattern, to be used when the DATA switch is set to the PRGM position. The order of data bits transmitted is left-to-right on the display. When this auxiliary function is selected, the pattern editor is in "exchange" mode. This means that any binary digits entered overwrite the digit at the cursor. Use the INSERT softkey to toggle in/out of insert mode. In insert mode, digits are inserted at the cursor without overwriting any others. Digits may be entered at the end of the pattern in either mode. The DELETE softkey deletes the digit at the cursor. The > and < keys on the MENU keypad are used to position the cursor. The ENTER key is used to save and implement all changes made to the pattern. The Δ key causes the FIREBERD to return to the unedited version of the pattern.</p>
Site Identification	34	SITE ID	Identify a site when the FIREBERD is used in a specific network. The site ID is entered by positioning the cursor under each "digit" (using the > and < keys on the MENU keypad) and using the UP or DOWN softkeys to select the desired ASCII character.
Results Print	35	RESULTS PRINT	Determine the content of a results printout. STD selects the standard printout. The LONG print includes all applicable results. The CUSTOM print allows each result to be included (ON) or excluded (OFF). Note that each result is included

A

Vertical text on the left margin, possibly a page number or header.

Table A-2
Non-Status-Select Auxiliary Functions (Continued)

Function	Number	Name	Description
Results Print (Continued)	35	RESULTS PRINT	in the printout only as long as it is applicable to the operating mode in use at the time of the printout.
Status Print Selection	36	STATUS PRINT	Enable (ON) or disable (OFF) the printing of individual status messages. When enabled, the status message is printed each time the status changes (if the printer is enabled, the LED is illuminated in the OFF/ON switch in the PRINTER block); when disabled, the LED in the ON/OFF switch is extinguished and the status message is not printed.
Printout Format	37	PRNT FRMT	Specify the printout format, as follows: COLUMN - choose 20-, 40-, or 80-column printouts. TERM - choose carriage return-linefeed (CRLF), carriage return (CR), linefeed (LF), or no (NONE) line termination. MODE - choose SLOW (maximum 20 characters per second) or FAST print speed (full baud rate).
RS-232 Print/ Controller Interface	38	RS-232	Configure the RS-232 printer/remote controller interface. The display for this function appears as: 232: bbbb.d.pppp where bbbb is the baud rate: 110, 300, 600, 1200, 2400, 4800, 9600. d is the number of data bits: 7,8. pppp is the parity: ODD, EVEN, NONE.
IEEE-488 Address	39	IEEE-488	View the current address of the IEEE-488 Printer/Remote control interface, as follows: 488: ADDR: 20 where 20 is the address of the controller (range: 0 - 31). Note that the controller is only addressable when auxiliary function 11 (I/O Driver Select) is used to specify IEEE-488 remote control; when IEEE-488 is specified for a printer, the message TALK appears in the display in lieu of an address.
Software Version	40	SOFTWARE VERSION	Display the current software version and the date the software was revised.

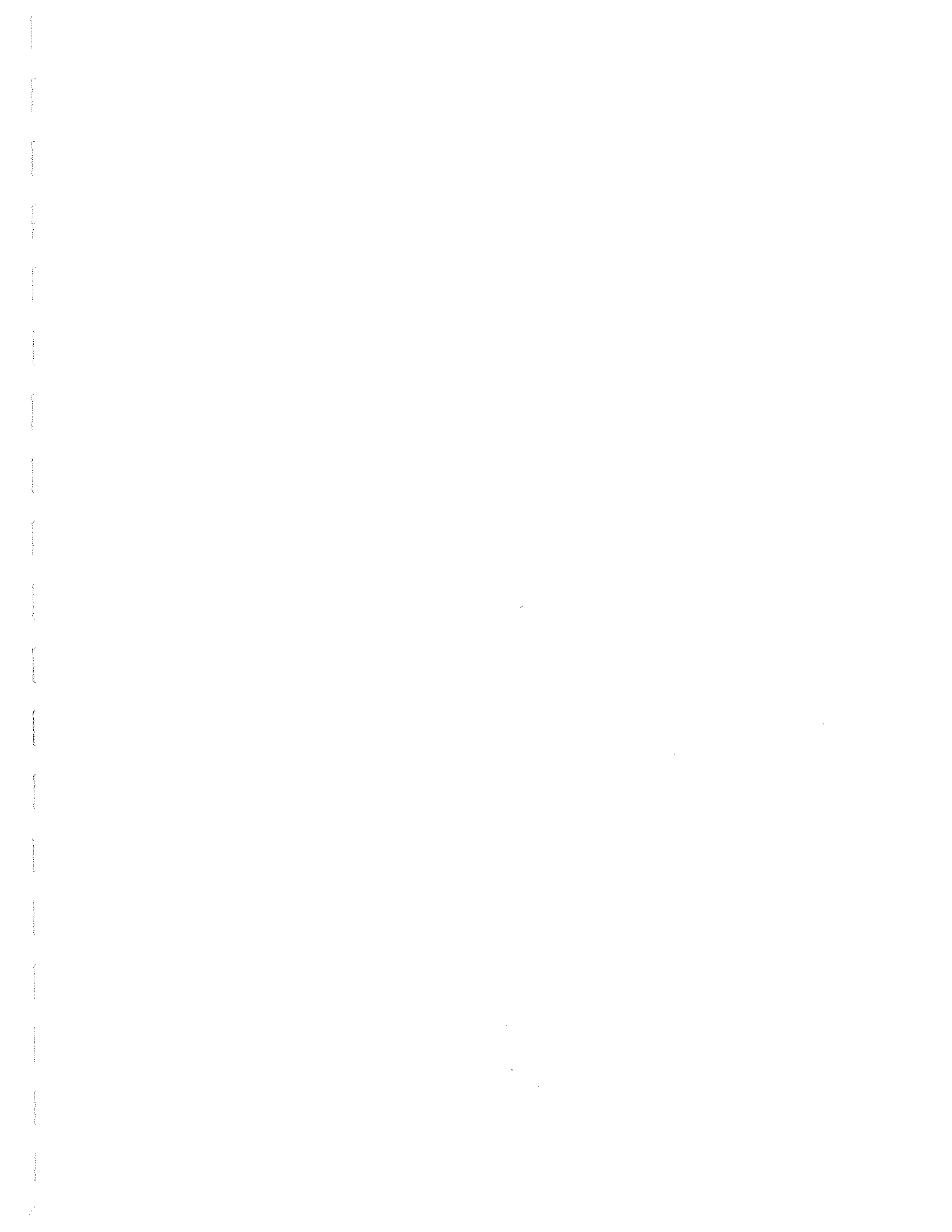


Table A-2
Non-Status-Select Auxiliary Functions (Continued)

Function	Number	Name	Description
User Message Selection	41	USER PATTERN	<p>Select from a series of patterns that are in addition to those available through the DATA switch: 1-7, 3-IN-24, T1-1 to T1-6, T1-mW, 1020 Hz, and DDS-1 to DDS-6.</p> <p>Long User Patterns (LUPs)</p> <p>Auxiliary function 41 can also be used to enter or edit up to three patterns of up to 2048 characters each. Any of these patterns may be used when the DATA switch is set to the USER position. Characters are entered in hexadecimal format (0-9 and A-F) from the MENU keypad; the > and < keys are used to position the cursor. In the hexadecimal format, 2 digits are required to define a character; thus, the cursor is 2 digits wide.</p> <p>The INSERT softkey is used to insert characters without overwriting the existing ones. When not inserting, the characters entered overwrite the characters at the cursor. Characters may be added at the end of the user message in either case.</p> <p>The DELETE softkey deletes the character at the cursor.</p> <p>The display for this function is:</p> <pre>xxxxxxxxxxxxx*yyyy</pre> <p>where xx is the user message and yyyy is the numerical position of the byte underlined by the cursor.</p> <p>After creating a message or editing an existing one, press the ENTER key to save and implement it.</p>
Recall Pre-Sync Loss Results	42	PRE SYNC LOSS	<p>Transfer the test results recorded from 2 to 4 seconds before a synchronization or power loss to the results display buffer. In such instances, an automatic display hold is performed, and test results are automatically sent to a printer, if one is enabled. If no sync or power loss has occurred since the test started, the message Pre sync/power loss results not available is displayed.</p>
Clear Non-Volatile RAM Settings	43	CLEAR NOV RAM	<p>Clear the FIREBERD 6000 of its current settings for stored programs, patterns, and user messages. When selected, all settings are returned to their factory-set values. The user must verify this operation before it is actually performed.</p>



Table A-2
Non-Status-Select Auxiliary Functions (Continued)

Function	Number	Name	Description
Histogram Setup	44	HISTOGRAM	Select the results to be graphed and the scale to be used for histogram plots.
User Message Synchronization Threshold	45	USR SYN THR	Select the number of unerrored bytes within the user message that must be received before pattern synchronization is established. PATL specifies that the entire pattern length must be received unerrored to declare pattern synchronization. The BYTE selection is used to specify a variable number of unerrored bytes (between 10 to 2048 bytes) that must be received to declare pattern synchronization. This function only affects synchronous user messages.
Asynchronous Data Timeout	46	ASYNC TIMEOUT	Select the action taken when no data is received in asynchronous timing mode. ON forces a synchronization loss after 10 seconds have passed without receiving data; OFF does not force a sync loss under identical conditions.
Time/Date Set	60	TIME/DATE	Set the FIREBERD time and date calendar. The display shows: HH:MM:00 DD/MM/YY When changing either the data or time, position the cursor under the field to be changed and enter the correct number from the keypad. All or part of the time/date may be modified. The hours are in 24-hour format and range from 00 to 24. Setting the minutes automatically sets the seconds to 00. The ENTER key implements the setting.
Clear Status	99	CLEAR FUNC IN USE	Reset the status-select auxiliary functions (1 to 10) to their factory-set (i.e., default) states. When selected, the AUX FUNC IN USE panel label is no longer illuminated.

1. Introduction

2. Background

3. Methodology

4. Results

5. Discussion

6. Conclusion

7. References

8. Appendix

9. Glossary

10. Index

11. Bibliography

12. Acknowledgments

13. Author Biographies

14. Contact Information

15. Declaration of Interest

16. Funding Sources

17. Data Availability

18. Ethics Approval

19. Supplementary Materials

APPENDIX B ANALYSIS RESULTS AND MESSAGES

B.1 ANALYSIS RESULTS

ERROR Category

Average Bit Error Rate (AVG BER) - The ratio of the number of bit errors counted to the number of data bits examined since the beginning of the test.

Bit Errors (BIT ERRS) - The number of errored data bits counted since the beginning of the test.

Bit Error Rate (BER) - The ratio of the number of bit errors counted over the last test interval to the number of data bits examined in the last test interval.

Blocks (BLOCKS) - The number of complete blocks received since the beginning of the test. The length of a block is set through Auxiliary Function 30.

Block Errors (BLK ERRS) - The number of complete blocks received since the beginning of the test that contain one or more bit errors.

Average Block Error Rate (AVG BLER) - The ratio of the number of block errors counted to the number of blocks examined since the beginning of the test.

Character Errors (CHAR ERR) - In asynchronous testing, the number of characters received since the beginning of the test that contain one or more data errors.

Pattern Slips (PAT SLIP) - The number of occurrences since the beginning of the test where data bits have been added to or deleted from the received pattern.

PERFORMANCE Category

G.821 Errored Seconds (GERR SEC) - The number of available seconds in which at least one bit error occurred.

G.821 Error-Free Seconds (G EFS) - The number of available seconds in which no bit errors occurred.

G.821 % Error-Free Seconds (G %EFS) - The ratio of the number of available seconds in which no errors were detected to the total number of available seconds, expressed as a percentage.

B

1
2
3
4
5
6
7
8
9
10
11
12
13
14
15
16
17
18
19
20
21
22
23
24
25
26
27
28
29
30
31
32
33
34
35
36
37
38
39
40
41
42
43
44
45
46
47
48
49
50
51
52
53
54
55
56
57
58
59
60
61
62
63
64
65
66
67
68
69
70
71
72
73
74
75
76
77
78
79
80
81
82
83
84
85
86
87
88
89
90
91
92
93
94
95
96
97
98
99
100

FIREBERD 6000 User's Guide

Degraded Minutes (DEG MIN) - The number of blocks of 60 non-severely-errored available seconds in which the average BER was worse than 10^{-6} . Note that CCITT Recommendation G.821 eases this requirement at 64 kHz: when the average BER over 60 seconds is 64 kHz, and four bit errors are counted, the minute is not considered to be degraded.

% Degraded Minutes (%DEG MIN) - The ratio of the number of degraded minutes to the number of minutes derived from available, non-severely errored seconds, expressed as a percentage.

Severely Errored Seconds (SES) - The number of available seconds during which the BER is higher than 10^{-3} .

% Severely Errored Seconds (%SES) - The ratio of the number of severely errored seconds to the number of available seconds, expressed as a percentage.

G.821 Violation-Free Seconds (G VFS) - The number of available seconds in which BPVs were not detected.

G.821 % Violation-Free Seconds (G %VFS) - The ratio of the number of available seconds in which BPVs were not detected to the total number of available seconds, expressed as a percentage.

Unavailable Seconds (UNA SEC) - The number of seconds judged unavailable by CCITT criteria.

Available Seconds (AVL SEC) - The number of seconds judged available by CCITT criteria.

% Available Seconds (%AVL SEC) - The ratio of the number of available seconds to the number of test seconds since initial pattern synchronization, expressed as a percentage.

Severely Violated Seconds (SVS) - The number of available seconds during which the BPV rate was higher than 10^{-3} .

% Severely Violated Seconds (%SVS) - The ratio of the number of severely violated seconds to the number of available seconds, expressed as a percentage.

Bit Errors Minus Severely Errored Seconds (ERR-SES) - The total number of bit errors, excluding the errors that occurred during severely errored seconds.

Bit Error Rate Minus Severely Errored Seconds (BER-SES) - The bit error rate, excluding the errors that occurred during severely errored seconds.

TIME Category

Pattern Sync Loss Seconds (PATL SEC) - The number of seconds during which the receiver was not in continuous pattern synchronization.

% Pattern Sync Seconds (%PAT SEC) - The ratio of the number of seconds in which pattern synchronization was achieved with no synchronization losses to the total number of seconds since initial pattern synchronization, expressed as a percentage.



