

50-12741-01
Rev. C

**T-BERD 107A
T-CARRIER ANALYZER
REFERENCE MANUAL**

DECEMBER 1994

©1993 TELECOMMUNICATIONS TECHNIQUES CORPORATION®
20440 Observation Drive
Germantown, Maryland 20876
(800) 638-2040 OR (301) 531-1330 (MD) • FAX (301) 638-0751
WWW Address: <http://www.ttc.com>

BRIDGTAP is a trademark and MULTIPAT
is a registered trademark of
Telecommunications Techniques Corporation (TTC),
A Dynatech Company.

SLC is a registered trademark of
AT&T Technologies, Inc.

Specs., terms, and conditions are subject to change
without notice.



TABLE OF CONTENTS

| SECTION | PAGE |
|--|------|
| GENERAL INFORMATION | |
| 1.1 INTRODUCTION | 1-1 |
| 1.2 INSTRUMENT OVERVIEW | 1-1 |
| 1.3 STANDARD FEATURES | 1-2 |
| 1.4 OPTIONS | 1-4 |
| 1.5 ACCESSORIES | 1-5 |
| 1.6 CABLES | 1-7 |
| 1.7 ORDERING INFORMATION | 1-8 |
| INSTRUMENT CHECKOUT AND MAINTENANCE | |
| 2.1 UNPACKING AND INITIAL INSPECTION | 2-1 |
| 2.2 EQUIPMENT INCLUDED | 2-1 |
| 2.3 WARNINGS AND CAUTIONS | 2-2 |
| 2.4 POWER REQUIREMENTS | 2-2 |
| 2.5 INSTRUMENT SELF-TEST/CHECKOUT | 2-5 |
| 2.6 MAINTENANCE | 2-19 |
| 2.7 BATTERY REPLACEMENT | 2-20 |
| 2.8 WARRANTY | 2-22 |
| 2.9 EQUIPMENT RETURN INSTRUCTIONS | 2-24 |
| INSTRUMENT DESCRIPTION | |
| 3.1 OVERVIEW | 3-1 |
| 3.2 MAINFRAME — TEST SETUP | 3-3 |
| 3.3 MAINFRAME — TEST CONNECTIONS | 3-17 |
| 3.4 MAINFRAME — TEST RESULTS | 3-21 |
| 3.5 MAINFRAME — TROUBLESHOOTING CONTROLS | 3-29 |
| 3.6 MAINFRAME — PRINTER CONTROL | 3-34 |



| SECTION | PAGE |
|--|------|
| 3.7 SLC DATALINK DECODE OPTION — INTRODUCTION | 3-35 |
| 3.8 SLC DATALINK DECODE OPTION — TEST SETUP | 3-35 |
| 3.9 SLC DATALINK DECODE OPTION — TEST RESULTS | 3-36 |
| 3.10 ADVANCED STRESS PATTERNS OPTION — INTRODUCTION | 3-39 |
| 3.11 ADVANCED STRESS PATTERNS OPTION — TEST SETUP | 3-39 |
| 3.12 ENHANCED ESF OPTION — INTRODUCTION | 3-43 |
| 3.13 ENHANCED ESF OPTION — TEST SETUP | 3-43 |
| 3.14 ENHANCED ESF OPTION — TEST RESULTS | 3-45 |
| 3.15 ENHANCED ESF OPTION — PRINTER CONTROL | 3-51 |
| 3.16 SMART LOOPBACK/COMMAND CODES OPTION — INTRODUCTION | 3-53 |
| 3.17 SMART LOOPBACK/COMMAND CODES OPTION — TEST SETUP | 3-53 |
| 3.18 SMART LOOPBACK/COMMAND CODES OPTION — TROUBLESHOOTING | 3-54 |
| 3.19 FRACTIONAL T1 OPTION — INTRODUCTION | 3-55 |
| 3.20 FRACTIONAL T1 OPTION — TEST SETUP | 3-55 |
| 3.21 FRACTIONAL T1 OPTION — TROUBLESHOOTING | 3-58 |

SECTION  TABLE OF CONTENTS

| SECTION | PAGE |
|--------------------------------------|------|
| AUXILIARY FUNCTIONS | |
| 4.1 INTRODUCTION | 4-1 |
| 4.2 AUXILIARY FUNCTIONS | 4-3 |
| TEST RESULTS | |
| 5.1 TEST RESULTS | 5-1 |
| 5.2 SUMMARY CATEGORY | 5-4 |
| 5.3 ERRORS CATEGORY | 5-12 |
| 5.4 SIGNAL CATEGORY | 5-15 |
| 5.5 TIME CATEGORY | 5-19 |
| 5.6 DATALINK CATEGORY | 5-20 |
| PRINTER OPERATION | |
| 6.1 COMPATIBLE PRINTERS | 6-1 |
| 6.2 PRINTER OPERATION | 6-1 |
| 6.3 CONNECTING THE PRINTER | 6-4 |
| 6.4 GENERATING A PRINTOUT | 6-5 |
| 6.5 TYPES OF PRINTOUTS | 6-7 |
| SPECIFICATIONS | |
| 7.1 INTRODUCTION | 7-1 |
| 7.2 GENERAL SPECIFICATIONS | 7-1 |
| 7.3 INPUT SPECIFICATIONS | 7-2 |
| 7.4 OUTPUT SPECIFICATIONS | 7-3 |
| 7.5 MEASUREMENTS | 7-4 |
| 7.6 CONNECTORS | 7-8 |
| 7.7 ALARM CRITERIA | 7-8 |
| 7.8 PATTERN SPECIFICATIONS | 7-10 |
| 7.9 LOOP CODES | 7-12 |
| 7.10 GROUNDING | 7-13 |
| 7.11 BATTERY | 7-14 |
| APPENDICES | |
| A FACTORY DEFAULT SETTINGS | A-1 |
| B CHANNEL TIME SLOT ASSIGNMENTS | B-1 |
| C STRESS PATTERNS | C-1 |
| D INTELLIGENT NETWORK EQUIPMENT ... | D-1 |



| SECTION | PAGE |
|---|------|
| FIGURES | |
| 2-1 T-BERD 107A TOP PANEL | 2-3 |
| 3-1 T-BERD 107A FRONT PANEL | 3-2 |
| 3-2 FRONT-PANEL DISPLAY AND SETUP SWITCHES | 3-4 |
| 3-3 TOP PANEL TEST CONNECTIONS | 3-17 |
| 3-4 TEST CONNECTIONS RELATED SWITCHES | 3-18 |
| 3-5 TEST RESULTS SWITCHES AND INDICATORS | 3-21 |
| 3-6 TROUBLESHOOTING CONTROLS AND INDICATORS | 3-30 |
| 6-1 RESULTS PRINTOUT | 6-8 |
| 6-2 SIMULATED BRIDGTAP RESULTS PRINTOUT | 6-10 |
| 6-3 SIMULATED MULTIPATTERN RESULTS PRINTOUT | 6-11 |
| 6-4 SMART NIU RESULTS PRINTOUT | 6-13 |
| 6-5 OVERFLOW RESULTS PRINTOUT | 6-14 |
| 6-6 CONTROLS PRINTOUT | 6-16 |
| TABLES | |
| 3-1 BRIDGTAP PATTERNS | 3-12 |
| 3-2 MULTIPAT PATTERNS | 3-13 |
| 4-1 T-BERD 107A AUXILIARY FUNCTIONS | 4-2 |
| 5-1 SIGNAL LEVEL TEST LOCATIONS | 5-14 |
| 6-1 PRINTER INTERFACE PARAMETERS | 6-3 |
| 7-1 PRINTER CONNECTOR PIN CONFIGURATION | 7-7 |
| A-1 FACTORY DEFAULT SETTINGS | A-1 |
| B-1 CHANNEL TIME SLOT ASSIGNMENTS | B-1 |
| D-1 INTELLIGENT NETWORK EQUIPMENT LOOP CODES | D-1 |
| D-2 INTELLIGENT NETWORK EQUIPMENT SELECTIONS | D-2 |

**SECTION
GENERAL
INFORMATION** **1**

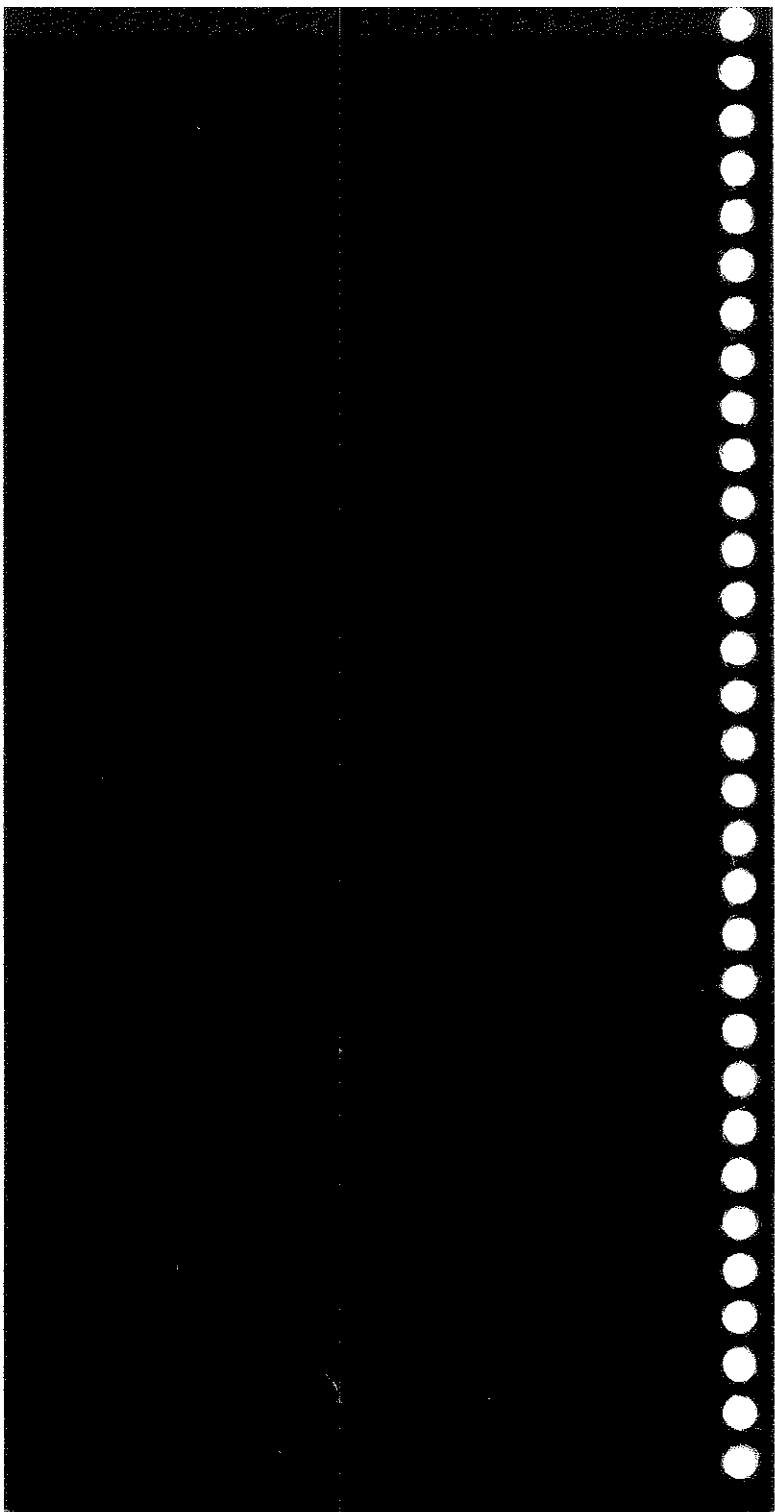



GENERAL INFORMATION

1.1 INTRODUCTION

This manual provides information about the physical features, functional operation, and specifications of the Telecommunications Techniques Corporation (TTC) T-BERD 107A T-Carrier Analyzer.

In addition to this manual, a *T-BERD 107A User's Guide* provides information on setting up and operating the T-BERD 107A in a number of in-service and out-of-service applications.

1.2 INSTRUMENT OVERVIEW

The T-BERD 107A is a full-featured, hand-held T1 test set designed for outside plant testing. It can be used during circuit installation, acceptance testing, and fault isolation. The T-BERD 107A can monitor a T1 circuit without interrupting service, generate and receive test patterns during out-of-service circuit testing, and emulate a network device, such as a Network Interface Unit (NIU) or Channel Service Unit (CSU). In addition, the T-BERD 107A detects and isolates problems related to customer premises equipment (e.g., NIU) and detects problems originating from the T1 span.



1.3 STANDARD FEATURES

D1D, D4, ESF, and SLC-96™ framing patterns offer compatibility with a variety of framing formats. An unframed mode is also available for applications where framing is not required.

Automated BRIDGTAP™ pattern sequence detects bridge taps on a T1 span by automatically generating 21 test patterns and monitoring the returned signal for errors.

Automated MULTIPAT™ pattern sequence generates five standard test patterns with variable durations that eliminate the need to perform separate tests with each pattern.

Logic error, bipolar violation, and frame error (CRC error if ESF framing) analysis are performed simultaneously with the associated error rate and errored seconds measurements.

Complete signal analysis includes signal level, timing slips, received clock frequency, and simplex current measurements.

In-band and ESF out-of-band loopback codes enable the instrument to loopback or emulate devices that accept either in-band or out-of-band loop codes.

Bit-Patterned Message (BPM) recognition enables the T-BERD 107A to identify and display BPMs from the ESF datalink in accordance with ANSI T1.403. In addition, the T-BERD 107A can generate BPMs.



Channel drop feature displays user-selected DS0 channel signaling bits, data bits, and VF frequency/level measurements. In addition, the selected DS0 channel is dropped to the internal speaker and the VF OUT jack for analysis by an external TIMS test set.

SUMMARY category displays either *ALLRESULTS OK* or any out-of-specification or non-zero results, eliminating the need to search through long lists of test results.

AUTO mode lets the T-BERD 107A configure itself to the proper framing, coding, and pattern. No setup is required when monitoring live circuits.

Logic error and bipolar violation (BPV) insertion enables the T-BERD 107A to simulate span and equipment errors.

Line Build-Out selections add troubleshooting capability to uncover marginal problems such as cable crosstalk and bridge taps.

Rechargeable battery and AC power adapter provide operating flexibility to meet different testing needs. The lead-acid battery provides four hours of continuous cord-free operation and can be recharged from the T-BERD 107A AC power adapter.

VF OUT jack enables the T-BERD 107A to drop a voice frequency signal from one channel to an external test set for analysis.

RS-232 interface connector enables the T-BERD 107A to print test results and test setup for various tests.



1.4 OPTIONS

SLC Datalink Decode Option (107A-1)

SLC-96 datalink major, minor, and power/miscellaneous alarms are decoded and reported on the front panel.

SLC-96 alarm seconds and alarm field size are calculated and reported on the front panel.

Advanced Stress Patterns Option (107A-2)

Fixed long patterns stress the timing and recovery circuitry of line repeaters.

Enhanced ESF Option (107A-3)

Monitors and reports on the received ESF datalink ANSI T1.403 Performance Report Message (PRM).

Adds PRM results to the DATALINK and SUMMARY categories.

Generates and transmits PRMs on the T1 signal.

Adds a SMARTNIU mode that enables the T-BERD 107A to query, retrieve, store, and clear T1 circuit statistics obtained by the performance monitor feature of the Westell NIU/Performance Monitor.

*Smart Loopback/Command Codes Option
(107A-4)*

Adds intelligent repeater loop codes that enable the T-BERD 107A to control intelligent network equipment, such as office repeaters, line repeaters, and maintenance switches.

Adds HDSL loop codes that enable the T-BERD 107A to control PAIRGAIN or equivalent HDSL circuit repeaters.

Fractional T1 Option (107A-5)

Fractional T1 (FT1) modes provide contiguous and noncontiguous, 56KxN and 64KxN, fractional T1 testing capabilities in D4, D1D, and ESF framing formats.

Adds three FT1 patterns (63, 511, and 2047) for testing DDS and fractional T1 circuits.

Adds VF tones (404 Hz, 1004 Hz, and 2804 Hz at user-selectable output level; 2713 Hz at 0.0 dBm) that can be transmitted on a user-selected DS0 channel.

1.5 ACCESSORIES

**T-BERD T1 Repeater Extender
(Model #41157)**

The T-BERD T1 Repeater Extender is a handheld circuit card extender that provides test access to T1 signals at span repeater housings. It is designed to



work in conjunction with a T-BERD T-Carrier Analyzer to perform out-of-service testing or monitoring of T1 signals along repeatered spans. The T-BERD T1 Repeater Extender enables the user to monitor T1 signals at repeater inputs and outputs without disrupting the span current loop. It also helps to sectionalize span lines by performing signal loopbacks at the repeater and by terminating repeater outputs. For more information, see the *T-BERD T1 Repeater Extender Operating Manual*.

T-BERD Repeater Power Supply (Model #41084)

The T-BERD Repeater Power Supply enables outside plant technicians to power-up a T1 circuit from the distribution frame in the central office to the customer site for testing the completion of the span. The T-BERD Repeater Power Supply delivers a constant current source of 60 mA, 100 mA, or 140 mA. The output voltage varies up to 260 VDC, depending on the number of repeaters powered, span length, and cable gauge. For more information, see the *T-BERD Repeater Power Supply Operating Manual*.

PR-40A Thermal Printer

The PR-40A is a thermal, 40-column/80-column, graphics printer. This printer connects to the AUXILIARY PORT (RS-232 printer interface) connector.



Replacement Battery

A replacement lead-acid battery can be ordered for the T-BERD 107A. Battery replacement instructions are provided in Section 2.7 Battery Replacement.

1.6 CABLES

The following cables provide an interconnection between the T-BERD 107A, other test sets, and the network.

| Model | Description |
|-----------|---|
| 10559 | WECO 310 plug to bantam plug (10') |
| 10599 | WECO 310 plug to bantam plug (4') |
| 10615 | Bantam plug to bantam plug (10') |
| 10648 | Bantam plug to alligator clips (10') |
| 11-008690 | T-BERD 107A AC power adapter |
| 30758 | Printer cable — 8-pin DIN to 25-pin D |
| 30840 | Dual bantam plug to mini test clips |
| 41649 | Dual bantam plug to 15-pin D (T-BERD Repeater Power Supply adapter cable) |

1.7 ORDERING INFORMATION

Contact TTC Customer Service Department at (800) 638-2049 for information on ordering options or accessories.





**SECTION
INSTRUMENT
&
CHECKOUT &
MAINTENANCE **2****

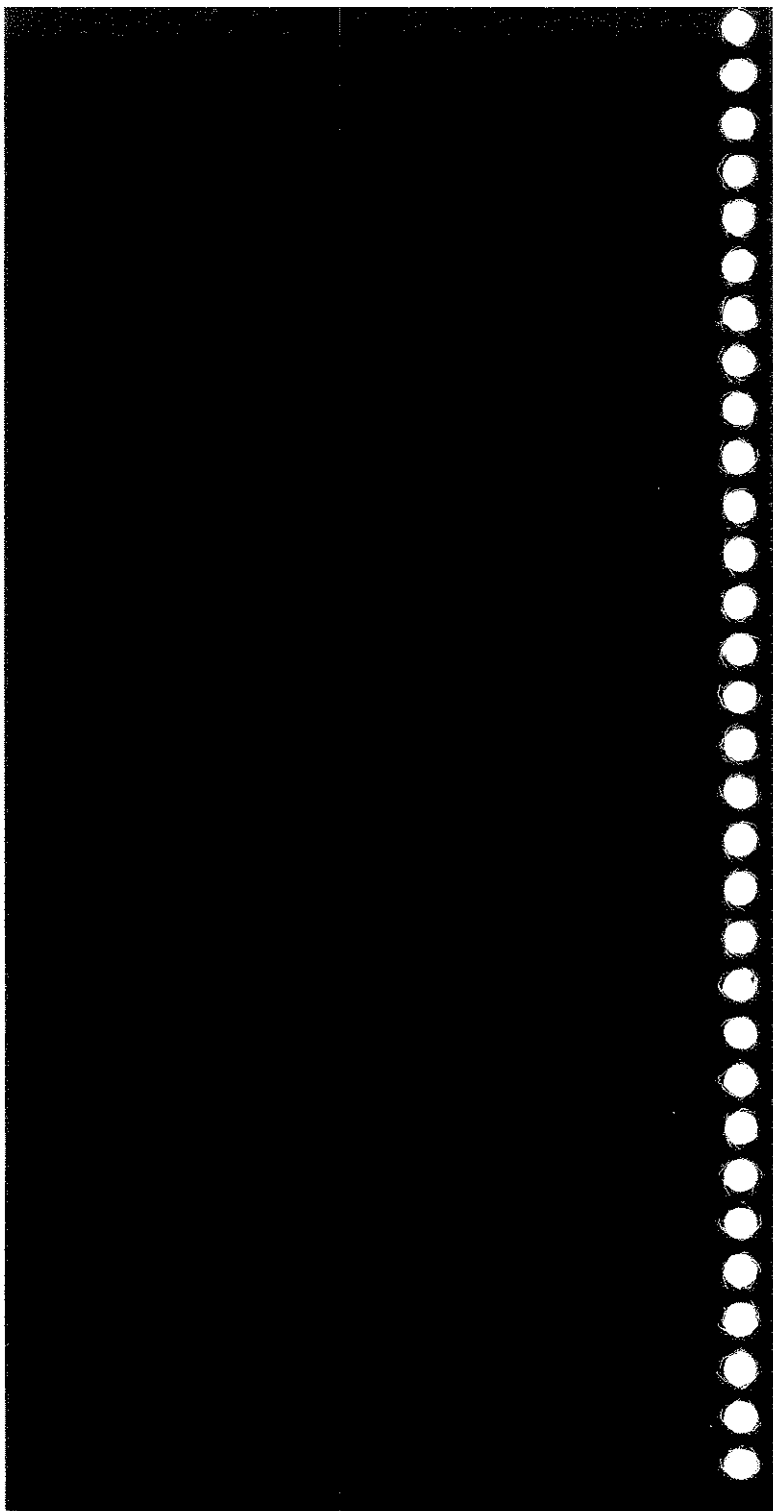



INSTRUMENT CHECKOUT AND MAINTENANCE

2.1 UNPACKING AND INITIAL INSPECTION

The T-BERD 107A shipping container should be inspected for damage when it is received. If the shipping container or shipping material is damaged, it should be kept until the contents of the shipment have been checked for completeness and the instrument has been checked mechanically and electrically. Procedures for checking the electrical performance of the instrument are given in Section 2.5 Instrument Self-Test/Checkout. If the contents are incomplete, or if the T-BERD 107A does not pass the Instrument Self-Test/Checkout, notify TTC at (800) 638-2049. If the shipping container is damaged, notify the carrier as well as TTC, and keep the shipping container and materials for the carrier's inspection.

2.2 EQUIPMENT INCLUDED

The following equipment should be present when the T-BERD 107A shipment is received and unpacked.

- * T-BERD 107A T-Carrier Analyzer
- * T-BERD 107A AC power adapter
- * Printer cable (8-pin DIN to 25-pin D)
- * Reference manual and user's guide
- * Carrying case



Check the purchase order against the option label(s) on the back panel of the T-BERD 107A to verify that the option(s) ordered are installed.

2.3 WARNINGS AND CAUTIONS

KEEP AWAY FROM LIVE VOLTAGES

Do not remove the instrument from the chassis while power is applied to the unit.

DO NOT OPERATE IN AN AMBIENT TEMPERATURE ABOVE 122°F (50°C)

Operating this unit in temperatures above 122°F (50°C) can cause damage to the unit.

2.4 POWER REQUIREMENTS

The T-BERD 107A can be powered from an external AC power supply (115 VAC) or an internal rechargeable battery. The AC ADAPTER connector is located on the top panel of the T-BERD 107A. The battery is located inside the lid panel of the T-BERD 107A. Complete AC power specifications are provided in Section 7 Specifications.

AC ADAPTER Connector — The T-BERD 107A AC power adapter plugs into this jack to provide line voltage to the unit (see Figure 2-1). If an AC power supply is connected, it automatically overrides the battery and supplies the T-BERD 107A with AC power.

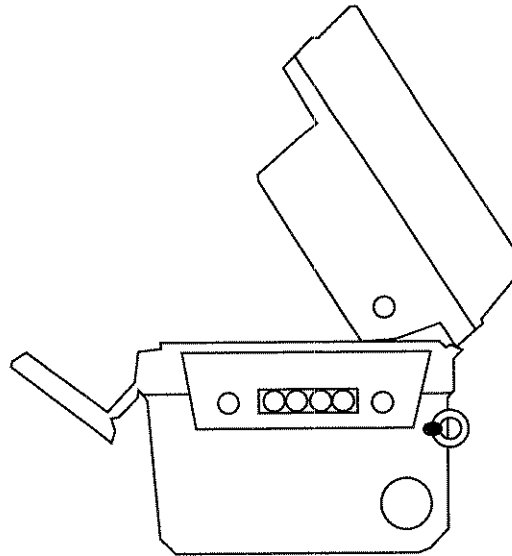

Figure 2-1
T-BERD 107A Top Panel

T-BERD 107A AC Power Adapter — The T-BERD 107A is equipped with an AC power adapter. The T-BERD 107A AC power adapter must be plugged into an approved two-contact electrical outlet.

POWER Switch — This switch is located on the lid panel and controls the power to the instrument. It is a two-position pushbutton switch; the down position turns on the T-BERD 107A, while the up position turns off the instrument.



AUTO POWER OFF Switch — This switch is located on the lid panel and cuts off the power to the instrument whenever the lid is shut. It is a spring-loaded pushbutton switch that remains extended when the lid is open. Whenever the lid is shut the **AUTO POWER OFF** switch is pressed in by contact with the front panel and turns off the T-BERD 107A. If the lid is opened after the T-BERD 107A was turned off by the **AUTO POWER OFF** switch, the T-BERD 107A turns on again.

The **AUTO POWER OFF** switch has a built-in delay of two seconds to prevent turning off the T-BERD 107A by accidental contact with the switch. This switch conserves battery power in case the lid is shut with the **POWER** switch still in the ON position.

Charging LED — This red LED is located on the top panel adjacent to the AC ADAPTER connector. The Charging LED illuminates anytime AC power is applied and the battery is charging.

Low Battery LED — This red LED is located on the front panel with the Alarms LEDs. The Low Batt LED illuminates approximately 15 minutes before the battery is completely drained of power. The battery is recharged anytime AC power is applied.



2.5 INSTRUMENT SELF-TEST/ CHECKOUT

Perform the following checkout procedure to verify the operation of the T-BERD 107A. Perform the option checkout procedure(s) for each installed option and skip the option checkout procedure(s) for the option(s) not installed.

Instrument Checkout Basic Setup

1. **Open the T-BERD 107A cover**
Release the latch on the right side of the instrument and open the cover to its full extension.
2. **Connect AC power to the T-BERD 107A**
Insert the T-BERD 107A AC power adapter into the AC ADAPTER connector on the top panel of the T-BERD 107A and plug the other end of the cable into an AC power source.
3. **POWER switch**
Press this switch on the lid panel to apply power to the T-BERD 107A. When the instrument is powered up, an automatic self-test is initiated that performs the following functions.
 - ⊗ Momentarily illuminates all LEDs.
 - ⊗ Illuminates the Charging LED.



- * The nonvolatile random access memory (NOVRAM) is checked and the front-panel switches are restored to the previous settings selected before the last power-down. If any changes are found, the factory default settings are reloaded and the message *NOVRAM LOST RELOAD NOVRAM* is displayed. The factory default settings are listed in Appendix A. The T-BERD 107A remains fully functional even though the switch settings may not be saved during the power cycle. While the instrument may be used, contact the TTC Customer Service Department at (800) 638-2049.

- * If it becomes necessary to restore all switch settings to the factory defaults, press and hold the **RESTART** switch, then turn the power on. Hold the **RESTART** switch down until the message *SYSTEM RESET* appears in the display. All the LEDs illuminate and the message *RELOAD NOVRAM* is displayed.

- * The T-BERD 107A RAM and EPROM are also checked during the self-test. If any error is found, the message *RAM FAILURE* or *ROM FAILURE* appears. In such instances, contact the TTC Customer Service Department at (800) 638-2049. There are no user-serviceable parts within the T-BERD 107A.



- The T-BERD 107A conducts a dynamic calibration of various measurement functions. During dynamic calibration, the message *CALIBRATING...* is displayed. If there is a problem, the message *CALIB ERROR* is displayed. In such instances, contact the TTC Customer Service Department at (800) 638-2049.

4. **Configure the T-BERD 107A switches**

| | |
|-----------------|--------------------|
| MODE | T1 (T1 unframed) |
| PATTERN | ALL ONES |
| CATEGORY | SUMMARY |
| RCVD | INTERNAL (LED OFF) |
| RX INPUT | TERM |
| LBO | 0 |

5. **Connect the TX jack to the RX jack**

Use a bantam plug to bantam plug cable to connect the TX jack to the RX jack.

6. **Signal verification**

Verify that the T1 Pulses and Pattern Sync LEDs illuminate.

NOTE: If the Low Battery LED is illuminated or illuminates at any time during this procedure, continue the instrument checkout. When the instrument checkout is complete, turn off the T-BERD 107A, but leave the T-BERD 107A AC power adapter attached to recharge the battery. Recharge the battery for a minimum of eight hours before operating the T-BERD 107A from the battery.



Mainframe Instrument Checkout

7. CATEGORY and RESULTS switches

Select the SIGNAL category RX LEVEL result in the RESULTS display. The value for this result should be $0 \text{ dBdsx} \pm 0.5 \text{ dB}$.

| | | |
|------|----------|------------|
| MODE | T1 | RX LEVEL |
| PATY | ALL ONES | +0.0 dBdsx |
| CATG | SIGNAL | 6.0 Vp-p |

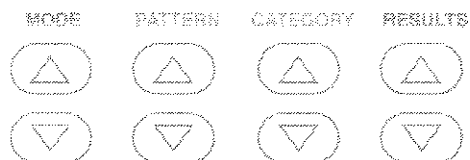

8. LBO switch

Select -7.5 and confirm that the RXLEVEL result changes to $-7.5 \text{ dBdsx} \pm 1.5 \text{ dB}$.

9. LBO switch

Select -15 and confirm that the RX LEVEL result changes to $-15 \text{ dBdsx} \pm 2.0 \text{ dB}$.

10. LBO switch

Select -22.5 and confirm that the RXLEVEL result changes to $-22.5 \text{ dBdsx} \pm 3.0 \text{ dB}$.

11. RESULTS switch

Select the RXFREQ result in the RESULTS display (SIGNAL category). Confirm that the value for this result is within the range of 1,543,999 to 1,544,001 Hz.



| | | |
|------|----------|------------|
| MODE | T1 | RX FREQ Hz |
| PATT | ALL ONES | |
| CATG | SIGNAL | 1544000 |

| MODE | PATTERN | CATEGORY | RESULTS |
|------|---------|----------|---------|
| | | | |
| | | | |

12. **Configure the T-BERD 107A switches**

| | |
|----------|-----------|
| MODE | T1 D4 |
| PATTERN | 1:7 |
| CATEGORY | SIGNAL |
| RESULTS | DATA BITS |

13. **Signal verification**

Verify that the T1 Pulses, Frame Sync, and Pattern Sync LEDs illuminate.

14. **Verify channel selection capability**

Press the **PATTERN** switch and verify the channel changes. Then press the **RESULTS** switch to select another test result.

| | | |
|------|--------|-----------|
| MODE | T1 D4 | DATA BITS |
| PATT | CH 01 | |
| CATG | SIGNAL | 01000000 |

| MODE | PATTERN | CATEGORY | RESULTS |
|------|---------|----------|---------|
| | | | |
| | | | |



15. **PATTERN switch**
Select the ALL ONES pattern. Verify that the Pattern Sync LED illuminates.
16. **Press the RESTART switch to restart the test**
17. **CATEGORY switch**
Select the SUMMARY category. The message *ALL RESULTS OK* should appear in the RESULTS display.

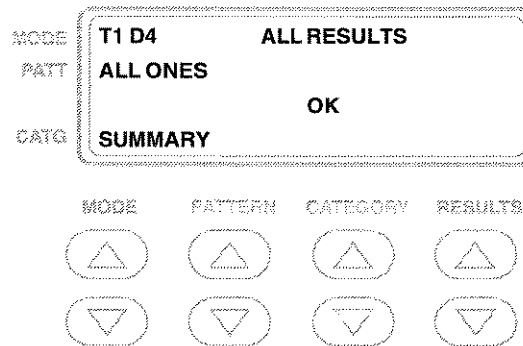

18. **CATEGORY switch**
Select the ERRORS category.
19. **ERR INS and RESULTS switches**
Press the **ERR INS** switch several times. After each activation of the **ERR INS** switch, check the BITERRORS and VIOLATIONS results and verify that each result increments by one each time the switch is pressed.



| | | | |
|------|----------|------------|--|
| MODE | T1 D4 | BIT ERRORS | |
| PATT | ALL ONES | 1 | |
| CATG | ERRORS | | |

| MODE | PATTERN | CATEGORY | RESULTS |
|------|---------|----------|---------|
| ▲ | ▲ | ▲ | ▲ |
| ▼ | ▼ | ▼ | ▼ |

| | | | |
|------|----------|------------|--|
| MODE | T1 D4 | VIOLATIONS | |
| PATT | ALL ONES | 1 | |
| CATG | ERRORS | | |

| MODE | PATTERN | CATEGORY | RESULTS |
|------|---------|----------|---------|
| ▲ | ▲ | ▲ | ▲ |
| ▼ | ▼ | ▼ | ▼ |

26. POWER switch

Press to turn the T-BERD 107A off. Leave the T-BERD 107A AC power adapter connected to the instrument and recharge the battery for a minimum of eight hours before operating the test set from the battery. A fully charged battery will typically provide four hours of continuous operation.



2.5.1 SLC Datalink Decode Option (107A-1) Installation Verification

If the SLC Datalink Decode Option is installed, perform the following procedure to verify its operation.

1. **Test setup**

Prepare the T-BERD 107A for testing in accordance with the *Instrument Checkout Basic Setup* procedure.

2. **MODE switch**

Verify that the SLC-M1 and SLC-M2 modes are available.

3. **CATEGORY switch**

Select the DATALINK category. Verify that the SLC datalink test results can be displayed.

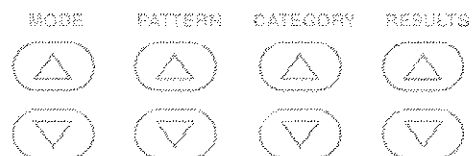
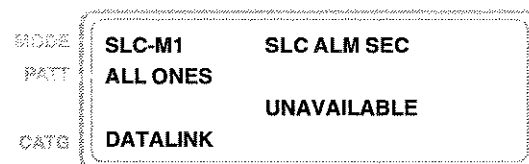

4. **POWER switch**

Press to turn the T-BERD 107A off.



2.5.2 Installation Verification for Options

Advanced Stress Patterns Option (107A-2)

If the Advanced Stress Patterns Option is installed, perform the following procedure to verify its operation.

1. Test setup

Prepare the T-BERD 107A for testing in accordance with the *Instrument Checkout Basic Setup* procedure.

2. PATTERN switch

Select the T1 DALY pattern.

3. Signal verification

Verify that the Pattern Sync LED illuminates.

4. Repeat for other patterns

Repeat Steps 2 and 3 for the T1-2/96, T1-3/54, T1-4/120, T1-5/53, 55 OCTET, and MIN/MAX patterns.

5. POWER switch

Press to turn the T-BERD 107A off.



Enhanced ESF Option (107A-3)

If the Enhanced ESF Option is installed, perform the following procedure to verify its operation.

1. **Test setup**

Prepare the T-BERD 107A for testing in accordance with the *Instrument Checkout Basic Setup* procedure.

2. **AUX and PATTERN switch**

Press the **AUX** switch to activate the auxiliary functions. Press the **PATTERN** switch to select the AUX DATALINK function.

3. **CATEGORY switch**

Press either the up or down arrow to select PRM TRAN.

4. **RESULTS switch**

Press either the up or down arrow to set PRM TRAN to EMUL CARR.

5. **AUX switch**

Press the **AUX** switch to return to the operating mode.

6. **CATEGORY and RESULTS switches**

Select the DATALINK category. Verify the ESF datalink far-end PRM results are available.



| | | |
|------|----------|------------|
| MODE | SELFST | FAR FRM ES |
| PATT | ALL ONES | |
| CATG | DATALINK | 0 |

| MODE | PATTERN | CATEGORY | RESULTS |
|------|---------|----------|---------|
| ▲ | ▲ | ▲ | ▲ |
| ▼ | ▼ | ▼ | ▼ |

7. **MODE switch**

Press the **MODE** switch to verify the SMARTNIU mode is available.

8. **PATTERN switch**

Press the **PATTERN** switch to verify the RESULTS and SETUP functions are available.

| | | | |
|------|----------|-------|-------|
| MODE | SMARTNIU | CLOCK | CLEAR |
| PATT | SETUP | ▲ | ▲ |
| CATG | | ▼ | ▼ |

| MODE | PATTERN | CATEGORY | RESULTS |
|------|---------|----------|---------|
| ▲ | ▲ | ▲ | ▲ |
| ▼ | ▼ | ▼ | ▼ |

9. **POWER switch**

Press to turn the T-BERD 107A off.

Smart Loopback/Command Codes Option (107A-4)

If the Smart Loopback/Command Codes Option is installed, perform the following procedure to verify its operation.

1. **Test setup**
Prepare the T-BERD 107A for testing in accordance with the *Instrument Checkout Basic Setup* procedure.
2. **AUX and PATTERN switch**
Press the **AUX** switch to activate the auxiliary functions. Press the **PATTERN** switch to verify the AUX SMARTNET function is available.
3. **CATEGORY and RESULTS switches**
Press the **CATEGORY** switch to select ILR (intelligent line repeaters). Press the **RESULTS** switch to select an intelligent line repeater manufacturer and model (e.g., TELTREND 7239 LD). Refer to Section 4.2 Auxiliary Functions for additional information on available intelligent repeaters.

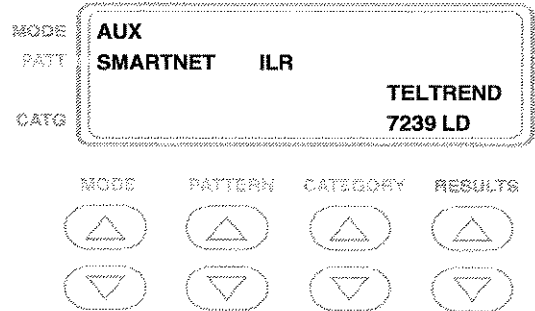



4. **LOOP CODES switch**

Select the PROG position (PROG LED illuminated).

5. **PATTERN, CATEGORY, and RESULTS switches**

Press the **PATTERN** switch to select the AUXLOOPCODE (PROG) function. Press the **CATEGORY** switch to verify the intelligent office and line repeater (IOR and ILR) selections and addresses are available with two digits for the ILR address. Press the **RESULTS** switch to verify the address can be programmed. Refer to Section 4.2 Auxiliary Functions for additional information on allowable address ranges for various intelligent repeaters.

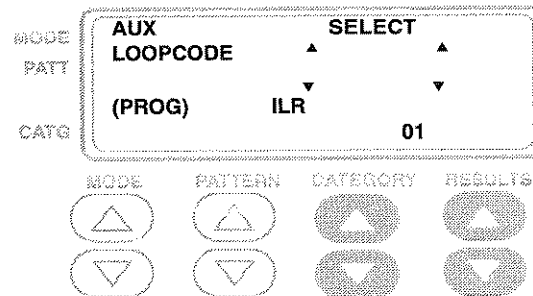

6. **AUX switch**

Press the **AUX** switch to exit the auxiliary functions.

7. **POWER switch**

Press to turn the T-BERD 107A off.



Fractional T1 (FT1) Option (107A-5)

If the Fractional T1 (FT1) Option is installed, perform the following procedure to verify its operation.

1. **Test setup**
Prepare the T-BERD 107A for testing in accordance with the *Instrument Checkout Basic Setup* procedure.
2. **MODE switch**
Verify the FT1 D4, FT1 D1D, and FT1 ESF modes are available.
3. **PATTERN switch**
Press the **PATTERN** switch to verify the 63, 511, and 2047 patterns, as well as one of the tones (404 Hz, 1004 Hz, 2804 Hz, or 2713 Hz) are available.
4. **AUX and PATTERN switch**
Press the **AUX** switch to activate the auxiliary functions. Press the **PATTERN** switch to verify the AUX FT1 CHAN, AUX FT1 IDLE, AUX FT1 RATE, and AUX VF TONE functions are available.

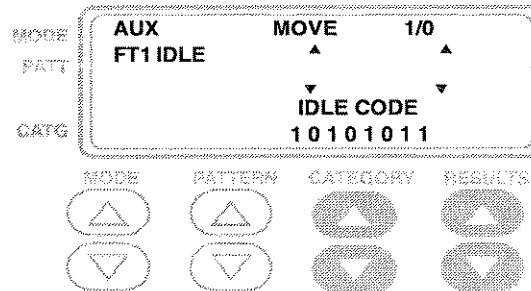

**5. POWER switch**

Press to turn the T-BERD 107A off.

2.6 MAINTENANCE

If the T-BERD 107A fails to operate and no front panel indicators are illuminated:

- * Check the T-BERD 107A AC power adapter to ensure that it is securely connected to the T-BERD 107A.
- * Make sure that the power supply is uninterrupted by plugging another electrical device into the electrical outlet used by the T-BERD 107A.
- * If AC power is not connected to the T-BERD 107A, connect the T-BERD 107A AC power adapter to the ADAPTER connector and a compatible AC power supply and charge the battery for a minimum of 15 minutes.

If the T-BERD 107A fails to operate after the T-BERD 107A AC power adapter and power supply are found to be in proper working order, contact the TTC Customer Service Department at (800) 638-2049. If front-panel indicators are illuminated, but the instrument does not operate properly:

- * Use the Instrument Self-Test/Checkout procedure in Section 2.5 to localize the problem.



- * Note those areas in which the Instrument Self-Test/Checkout procedure fails, then contact TTC for assistance.

2.7 BATTERY REPLACEMENT

The rechargeable lead-acid battery is located in the lid panel. The battery can be replaced in accordance with the following procedure. To order a replacement battery contact TTC Customer Service Department at (800) 638-2049.

1. **Turn off the unit and remove AC power**
Press the **POWER** switch to turn off the T-BERD 107A and remove the T-BERD 107A AC power adapter from the AC ADAPTER connector.
2. **Disconnect all cables**
Disconnect all cables from the connectors on the top panel of the T-BERD 107A.
3. **Remove the screws on the lid panel**
Using a Phillips-head screwdriver, remove and retain the six screws from the lid panel.
4. **Separate the lid panel from the case**
Remove the lid panel to expose the battery.

**5. Remove the old battery**

Lift the battery out of the spring-steel brackets and disconnect the battery connector clip by prying up on the left side of the clip. Set the old battery aside for proper disposal.

NOTE. Once the old battery is disconnected, the new battery must be installed and connected within ten minutes to avoid losing NOVRAM. If the battery replacement takes longer than ten minutes, the NOVRAM memory is lost (including print buffers) and the T-BERD 107A will start up with the default settings for all parameters.

6. Install the new battery

Fasten the connecting clip onto the new battery. Place the new battery between the spring-steel brackets and slide the battery up so that the top right corner rests against the L-shaped frame.

7. Replace the lid panel

Replace the lid panel over the battery and install the six screws removed in Step 3.

8. Connect AC power

Connect AC power to the T-BERD 107A and charge the replacement battery for eight hours.



2.8 WARRANTY

2.8.1 Warranty Policy

All equipment manufactured by TTC is warranted against defects in material and workmanship. This warranty applies only to the original purchaser and is non-transferable unless express written authorization of the warranty transfer is granted by TTC. No other warranty is expressed or implied. TTC is not liable for consequential damages.

Liability under this warranty extends only to the replacement value of the equipment. The warranty is void under the following conditions.

- * Equipment has been altered or repaired without specific authorization from TTC.
- * Equipment is installed or operated other than in accordance with instructions contained in TTC literature and operating manuals.

2.8.2 In-Warranty Service

Equipment in warranty must be returned to the factory with shipping prepaid. The equipment should be packed and shipped in accordance with instructions in Section 2.9 Equipment Return Instructions. Before returning any equipment, the customer must obtain a Return Authorization (RA) number by contacting the TTC Repair Department. The RA number should then appear on all paperwork and be clearly marked on the outside of the shipping container.



After the equipment is repaired by TTC, it will be tested to applicable specifications, burned-in for at least 24 hours, retested, and returned to the customer with shipping prepaid. A brief description of the work performed and the materials used will be provided on the Equipment Repair Report furnished with the returned equipment.

2.8.3 Out-of-Warranty Service

The procedure for repairing out-of-warranty equipment is the same as that used for equipment still in warranty. However, there is a minimum charge applied to each request for out-of-warranty service. The minimum charge guarantees the customer an estimate of the repair costs and is used as credit against actual materials and labor costs should the equipment be repaired. Contact the TTC Repair Department for specific information on the minimum out-of-warranty repair charge.

The customer will be billed for parts plus standard labor rates in effect at the time of the repair. The customer will also be required to furnish a purchase order number before repair work can be started, and a hard copy of the purchase order must be received by TTC before the repaired equipment may be shipped to the customer. A description of the labor and materials used will be provided in the Equipment Repair Report.

Once an out-of-warranty repair is made, the repaired part or component is warranted for 90 days. This warranty applies only to the part or component that was repaired; other parts or components are not covered under the 90-day repair warranty.



2.9 EQUIPMENT RETURN INSTRUCTIONS

To all equipment returned for repair, the customer should attach a tag that includes the following information.

- Owner's name and address.
- A list of the equipment being returned and the applicable serial number(s).
- A detailed description of the problem or service requested.
- The name and telephone number of the person to contact regarding questions about the repair.
- The Return Authorization (RA) number.

It is recommended that all switches be left in the positions they were in when the problem occurred. This is requested so that the TTC repair group can analyze the switch positions along with a detailed description of the problem or of the service requested.

If possible, the customer should return the equipment using the original shipping container and material. If the original container is not available, the unit should be carefully packed so that it will not be damaged in transit; when needed, appropriate packing materials can be obtained by contacting TTC's Repair Department. TTC is not liable for any damage that may occur during shipping. The customer should clearly mark the TTC-issued RA number on the outside of the package and ship it prepaid and insured to TTC.

**SECTION
INSTRUMENT
DESCRIPTION** **3**

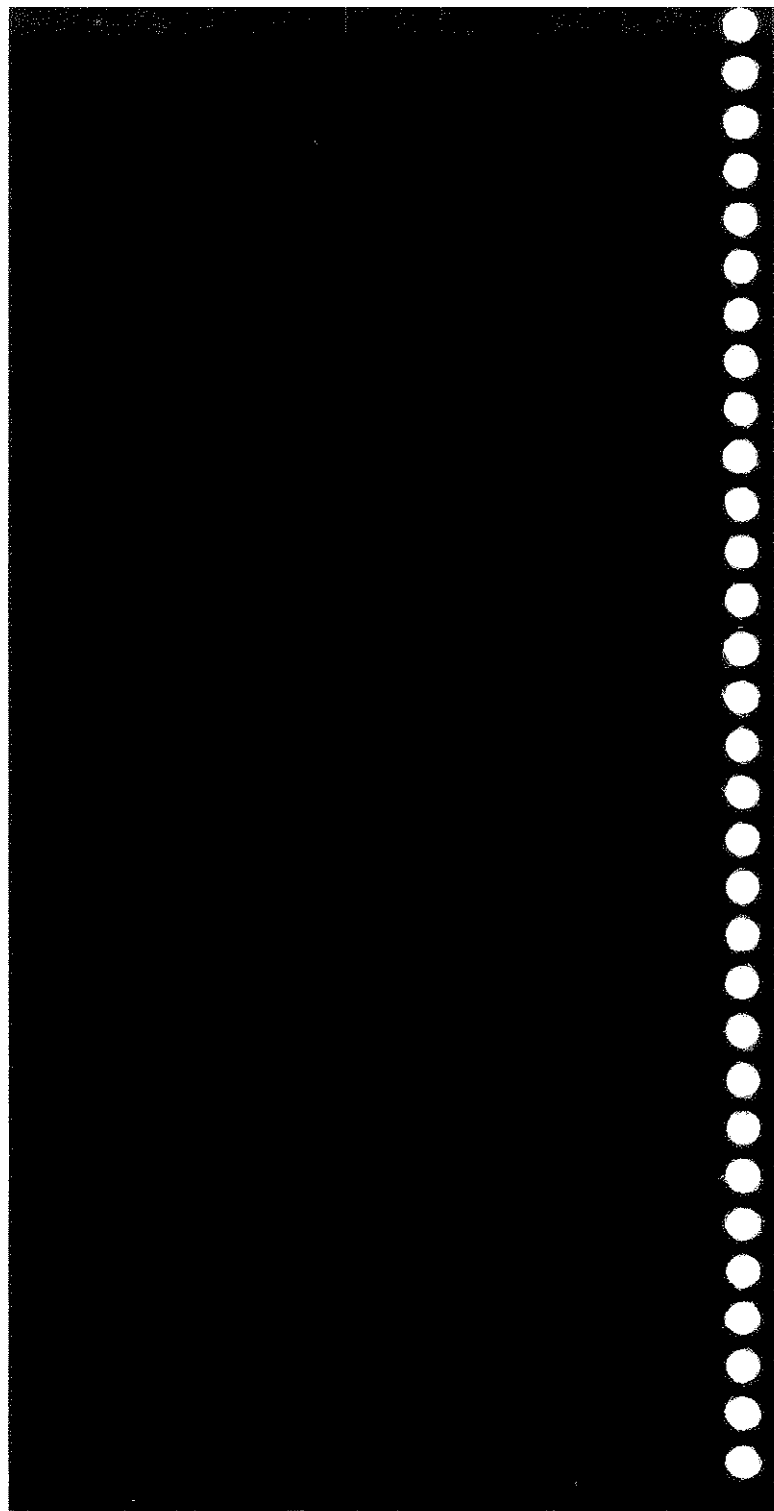



INSTRUMENT DESCRIPTION

3.1 OVERVIEW

This section may be used as a reference during testing and as a guide to understanding the functions of the T-BERD 107A (see Figure 3-1). The controls, indicators, and connectors of the mainframe and of each of the options are discussed in detail in the following order.

- * Mainframe
- * SLC Datalink Decode Option (107A-1)
- * Advanced Stress Patterns Option (107A-2)
- * Enhanced ESF Option (107A-3)
- * Smart Loopback/Command Codes Option (107A-4)
- * Fractional T1 (FT1) Option (107A-5)

The switches, indicators, and connectors are presented in the following functional areas:

Test Setup — Describes the front panel controls used to configure the instrument for the T1 circuit being tested.

Test Connections — Discusses the T1 circuit connectors, associated switches, and displays used to access the T1 circuit at central office equipment, span repeater housings, and at customer premises equipment.

Test Results — Presents the controls and indicators used to start and run a test, and describes how to view, collect, and analyze the test results.

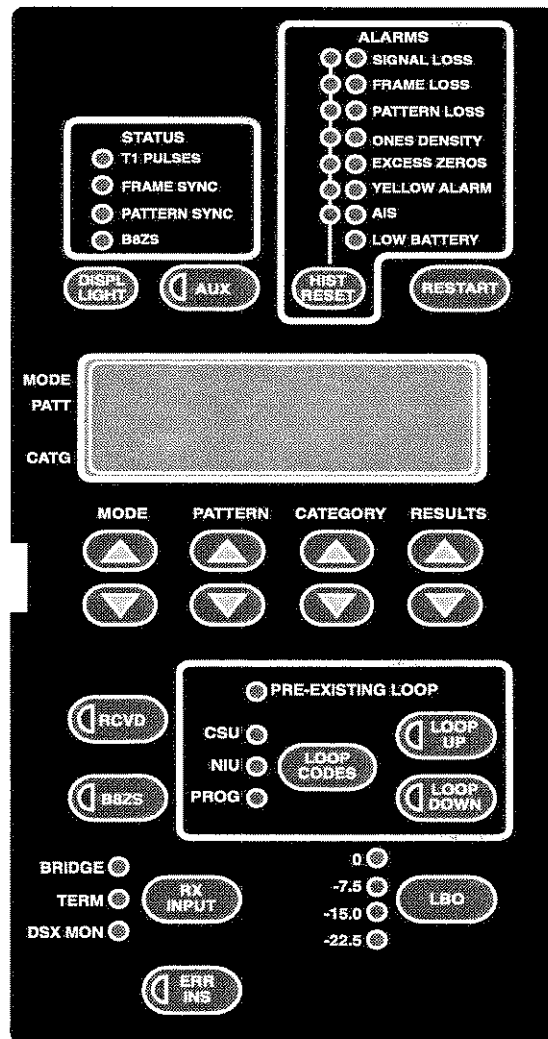

Figure 3-1
T-BERD 107A Front Panel



Troubleshooting Controls — Describes the controls used to troubleshoot and test the circuit.

Printer Control — Explains how to generate printouts manually or automatically.

NOTE: Throughout this section, a circled number appears after each switch, indicator, and connector. These numbers match the callout numbers in the applicable figure.

3.2 MAINFRAME — TEST SETUP

The following controls and indicators (see Figure 3-2) are described in the order that you would normally use them to set up the T-BERD 107A to test a circuit from a DS1 access point:

- Help panel
- Front-panel display ①
- **MODE** switch ②
- **PATTERN** switch ③
- **B8ZS** switch ④
- **RCVD** switch ⑤
- **AUX** switch ⑥

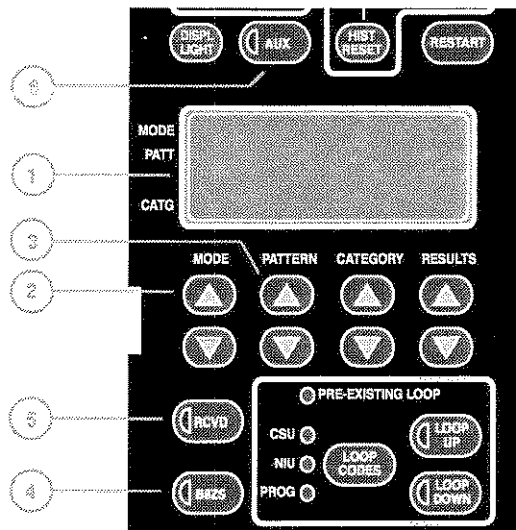

Figure 3-2
Front-Panel Display and Setup Switches

Help Panel

The T-BERD 107A features a help panel in the lid of the instrument. It provides a quick reference of:

- Test setup for sending loop codes
- Test setup for dropping a channel
- Available results, grouped by category

Front-Panel Display

Operating modes, test results, test patterns, and auxiliary functions appear in the two window, four-line, Liquid Crystal Display (LCD).



The first window contains the current operating mode, the test pattern, and the test results category. The labels on the left of the front panel display are abbreviations for the contents of the adjacent display. Pressing the **MODE** switch changes the operating mode and the MODE display (labeled MODE). Pressing the **PATTERN** switch changes the test pattern and the PATTERN display (labeled PATT). Pressing the **CATEGORY** switch changes the test results category and the CATEGORY display (labeled CATG).

The second window (RESULTS display) contains test results, auxiliary function parameters, or operating mode status messages. The **RESULTS** switch controls the RESULTS display.

Both windows of the display are used when an auxiliary function is activated.

MODE Switch ②

This switch selects the transmitted framing format (e.g., T1 D4 or T1 ESF) and configures the receiver for the selected framing format. It also configures the T-BERD 107A for Test and Line Loopback modes to emulate a CSU or repeater loopback. The **MODE** switch can place the instrument in a self-test mode to verify instrument operation or in an auto-configure mode which allows the instrument to automatically configure itself to the received data pattern and framing format.



Pressing the **MODE** switch (up arrow or down arrow) scrolls the mode selections in the display. Releasing the **MODE** switch on a displayed mode selects that mode.

NOTE: Changing the **MODE** switch position clears all test results and causes a test restart.

The following operating modes are listed in factory default order.

SELF TST — Configures the T-BERD 107A in a self-test loopback mode which loops the transmit output to the receive input. The data is transmitted with ESF framing. The **RCVD** switch is automatically set to internal timing. When leaving self test mode, the **RCVD** switch reverts to its previous timing position. Any test pattern can be selected.

AUTO — Automatic configure mode enables the T-BERD 107A to automatically configure itself to the received framing format when monitoring live data. When monitoring test patterns for an end-to-end test, the **AUTO** mode configures the T-BERD 107A to the received framing format and pattern.

While attempting to identify the received signal's framing and pattern, the T-BERD 107A displays *AUTO* in the **MODE** display and *scanning* in the **PATTERN** display. When auto-configuration is successful, both the received framing mode and pattern (if the signal is



recognized as a pattern) are displayed in lower-case letters in the MODE and PATTERN displays. When the received signal is not recognized as a pattern, the word *live* appears in the PATTERN display, and the instrument performs as in T1 TLB mode.

T1 — T1 unframed mode configures the T-BERD 107A to transmit and receive unframed T1 data for testing unframed T1 circuits or T1 circuits with proprietary framing formats.

T1 D4 — T1 D4 superframe mode configures the T-BERD 107A to transmit and receive D4 framed T1 data for testing D4 framed circuits. The T1 D4 mode is compatible with all superframe framing formats including: D1D, D2, and D3. While T1 D4 mode framing is compatible with T1 D1D framing for most test applications, the channel time slot assignments are different (see Appendix B).

T1 ESF — T1 extended superframe mode configures the T-BERD 107A to transmit and receive ESF framed T1 data for testing ESF framed circuits.

T1 SLC — T1 subscriber loop carrier mode configures the T-BERD 107A to transmit and receive SLC framed T1 data when testing SLC-96 framed circuits. The instrument ignores the SLC datalink (F) bits in the received signal. The SLC datalink bits are set to all zeros in the transmitted test pattern.



T1 D1D — T1 D1D superframe mode configures the T-BERD 107A to transmit and receive D1D framed T1 data for testing D1D framed circuits.

T1 TLB — T1 test loopback mode configures the T-BERD 107A to echo the received data and framing. This mode allows the T-BERD 107A to emulate a CSU in loopback. The T-BERD 107A configures itself to the received framing (or unframed) mode. If the received data pattern matches the selected test pattern (i.e., QRSS), pattern synchronization is declared; Pattern Sync LED illuminates. BPVs *are removed* from the received signal. However, BPVs, logic errors, and B8ZS line code *can be* inserted into the retransmitted data stream using the **ERR INS** switch and the **B8ZS** switch, respectively. To obtain logic error test results, the T-BERD 107A test pattern must be set to the received test pattern.

In the T1 TLB mode, the **LOOP CODES**, **LOOP UP**, and **LOOP DOWN** switches are disabled, and the **RCVD** switch automatically defaults to recovered timing (LED illuminated).

T1 LLB — T1 line loopback mode configures the T-BERD 107A in a T1 Line Loopback (LLB) mode in which all received data and framing is echoed by the transmitter. This mode allows the T-BERD 107A to emulate a repeater. The T-BERD 107A configures itself to the received framing (or unframed) mode. If the received data pattern matches the selected test pattern (i.e., QRSS), pattern synchronization is declared; Pattern Sync LED illuminates. BPVs *are not removed* from the received signal. The



ERR INS and **B8ZS** switches are disabled in this mode. To obtain logic error test results, the T-BERD 107A test pattern must match the received test pattern.

In the T1 LLB mode, the **LOOP CODES**, **LOOP UP**, and **LOOP DOWN** switches are disabled, and the **RCVD** switch automatically defaults to recovered timing (LED illuminated).

AUTO LLB — Automatically responds to a received loop-up code. AUTO LLB is not selectable by the **MODE** switch. The AUX AUTORESP function must be set to AUTO RESPONSE for the T-BERD 107A to respond to a received loop code. The T-BERD 107A will only respond to a loop code that matches the loop code type selected in the AUX CSU LOOP function, AUX NIU LOOP function, or AUX PROG LOOP function and by the **LOOP CODES** switch. In AUTO LLB mode, the T-BERD 107A functions the same as the T1 LLB operating mode.

AUTO LLB mode is enabled after receiving either five seconds of an in-band loop-up code or 250 ms of an ESF out-of-band loop-up code. If the T-BERD 107A is set to T1 LLB or T1 TLB mode, it will not respond to the received loop codes. The AUTO LLB mode is exited by receiving an in-band or an ESF out-of-band loop-down code, or by powering down the instrument. When the loopback is disabled, the instrument returns to the previously selected operating mode.



PATTERN Switch

This switch selects the transmitted test pattern and configures the receiver for the selected test pattern. Press either the up arrow or down arrow to scroll through the available selections. Release the switch when the desired selection appears in the PATTERN display. Changing the **PATTERN** switch position clears all test results and causes a test restart.

When the DATA BITS or VFRESULTS test results are displayed for a user-selected DS0 channel, the **PATTERN** switch is used to change the channel.

The following test patterns are available:

ALL ONES — ALL ONES is a fixed test pattern of AMI pulses (marks) and is generally used to stress span repeater current regulator circuits. It can be used as an Alarm Indication Signal (AIS) in unframed circuits, or a keep alive signal, idle code, or red alarm in other circuits.

1:1 — 1:1 is a fixed test pattern of alternating AMI ones (marks) and zeros (spaces). 1:1 is generally used to perform a minimum level stress test on clock recovery circuits.

1:7 — 1:7 is a fixed test pattern of F0100 0000. The pattern is aligned with the framing (F) bits as indicated. 1:7 is generally used to stress the minimum ones density requirement for AMI-encoded T1 circuits.

2 IN 8 — 2 IN 8 is a fixed test pattern of F0100 0010. The pattern is aligned with the framing (F) bits as indicated. 2 IN 8 is generally used to stress the minimum ones density for B8ZS-encoded T1 circuits.



3IN24 — 3 IN 24 is a fixed test pattern of F0100 0100 0000 0000 0000 0100... The pattern is aligned with the framing (F) bits as indicated. 3 IN 24 provides the minimum ones density and the maximum excess zeros (15) requirements to stress T1 circuits. When the pattern is framed, it violates the minimum ones density requirements.

T1-QRSS — T1-QRSS is a modified $2^{20}-1$ pseudo random pattern which allows a maximum of 14 sequential zeros and 20 sequential ones. The Quasi-Random Signal Source (QRSS) pattern simulates live data for T1 applications.

BRIDGTAP — The BRIDGTAP pattern determines if bridge taps are connected to a T1 span by sequentially testing the span with 21 test patterns that have a variety of ones and zeros densities. The T-BERD 107A monitors the received test pattern for bit errors, BPVs, and frame errors. If signal errors are not detected, the span does not have a bridge tap connected to it. However, if signal errors are detected, the span may have one or more bridge taps connected to it and further sectionalization is required.

When BRIDGTAP is selected, the 21 test patterns are transmitted continuously in the order shown in Table 3-1. As the patterns are transmitted, the word BRIDGTAP alternates with the name of the test pattern being transmitted. The test patterns are identified in the PATTERN display in lowercase characters (e.g., ALLONES = *all ones*). One complete BRIDGTAP pattern sequence takes approximately 10 minutes and 30 seconds to transmit.



Table 3-1
BRIDGTAP Patterns

| Pattern Name | Bit Pattern (F = Framing bit) |
|--------------|--|
| ALLONES | F 1111 |
| 1:1 | F 1010 |
| 1:3 | F 0100 |
| 1:5 | F 0100 00 |
| 1:6 | F 0100 000 |
| 1:7 | F 0100 0000 |
| 2:8 | F 1100 0000 00 |
| 2:9 | F 1100 0000 000 |
| 2:10 | F 1100 0000 0000 |
| 2:11 | F 1100 0000 0000 0 |
| 2:12 | F 1100 0000 0000 00 |
| 2:13 | F 1100 0000 0000 000 |
| 2:14 | F 1100 0000 0000 0000 |
| 3 IN 18 | F 1101 0000 0000 0000 00 |
| 3 IN 19 | F 1100 1000 0000 0000 000 |
| 3 IN 20 | F 1100 0100 0000 0000 0000 |
| 3 IN 21 | F 0100 0100 0000 0000 0000 1 |
| 3 IN 22 | F 0100 0100 0000 0000 0000 10 |
| 3 IN 23 | F 0100 0100 0000 0000 0000 100 |
| 3 IN 24 | F 0100 0100 0000 0000 0000 0100 |
| QRSS | 2 ²⁰ -1 pseudo random pattern with 14-zero suppression |

The BRIDGTAP pattern is designed to operate with AMI coding to test a span for bridge taps. Using B8ZS coding redistributes the test pattern energy making it less effective in detecting bridge taps.



MULTIPAT — The MULTIPAT pattern consists of five commonly used test patterns that allow the T-BERD 107A to test a T1 span without having to select each test pattern individually. The T-BERD 107A monitors the received test patterns for bit errors, BPVs, and frame errors.

When MULTIPAT is selected, the five test patterns are transmitted for a user-determined duration in the order that they appear in Table 3-2. An auxiliary function is used to individually set the duration for each test pattern (see Section 4 Auxiliary Functions for more information). As the patterns are transmitted, the word MULTIPAT alternates with the name of the test pattern being transmitted. The test patterns are identified in the PATTERN display in lower-case letters (e.g., ALL ONES = *all ones*).

Table 3-2
MULTIPAT Patterns

| Pattern Name | Bit Pattern (F = Framing bit) |
|--------------|---|
| ALL ONES | F 1111 |
| 1:7 | F 0100 0000 |
| 2 IN 8 | F 0100 0010 |
| 3 IN 24 | F 0100 0100 0000 0000 0000 0100 |
| T1-QRSS | $2^{20}-1$ pseudorandom pattern with 14-zero suppression |



USER1, USER2, USER3— USER1, USER2, and USER3 provide the ability to transmit a user-programmable 3- to 24-bit pattern. This allows the T-BERD 107A to transmit specific bit patterns to test circuit sensitivity to a particular pattern. The pattern is entered in binary form through the AUX USER1, AUX USER2, and AUX USER3 functions. The pattern is transmitted starting from left to right.

ALL ZERO— The ALL ZERO pattern allows the T-BERD 107A to test T1 circuits for B8ZS clear channel capability. The pattern can be transmitted framed or unframed, and should always be transmitted with B8ZS coding selected.

When using the ALL ZERO pattern and B8ZS coding, the T-BERD 107A can test a circuit for spans that are not configured for or are incompatible with B8ZS encoded data by monitoring the received signal for the normal B8ZS sequence, 000V 10V1 (where V is a bipolar violation). However, if the T-BERD 107A receives the B8ZS sequence in an alternate mark inversion (AMI) format (0001 1011) instead of all zeros (0000 0000) after decoding, the T-BERD 107A reports the sequence as an error and displays the message *NOT B8ZS COMPATIBLE* in the SUMMARY category. The failure of the network to maintain the B8ZS sequence in the



received ALL ZERO pattern can occur at a multiplexer or DCS with an improperly set coding option; the coding option would be set for AMI instead of B8ZS.

B8ZS Switch

This LED switch determines whether the T-BERD 107A transmits data with AMI coding or B8ZS coding. The LED within the switch illuminates when B8ZS coding is selected and is extinguished when AMI coding is selected.

The **B8ZS** switch affects the transmitter and the Excess Zeros LED operation; B8ZS decoding is performed automatically on the receiver. The B8ZS status LED illuminates when zero substitution codes are detected in the received data. The Excess Zeros LED illuminates when there are 16 or more consecutive zeros in the AMI position or when there are 8 or more consecutive zeros in the B8ZS position.

The message *B8ZS DETECTED* is displayed in the SUMMARY category when B8ZS coding is detected and the **B8ZS** switch is set to the AMI position. When the **B8ZS** switch is set to the B8ZS position, the selected pattern is ALL ZERO, and the instrument receives the sequence 0001 1011, the message *NOT B8ZS COMPATIBLE* is displayed. This message indicates that a non-B8ZS compatible piece of equipment regenerated the transmitted signal.

**RCVD Switch** ⑤

This LED switch sets the transmit timing source to either recovered or internal. The LED within the switch illuminates when recovered timing is selected and is extinguished when internal timing is selected. If recovered timing is selected but there is no signal, the switch LED will blink and internal timing is automatically provided until a signal is received.

In internal timing, the transmit data is generated with a fixed internal crystal oscillator. In recovered timing, the transmit timing source is taken from the clock recovered from the received data. In T1 LLB, T1 TLB, or AUTO LLB modes, the T-BERD 107A is automatically set to recovered timing.

AUX Switch ⑥

This LED switch allows access to the auxiliary functions, which configure parameters that are less frequently used and do not have dedicated switches. The LED within the switch illuminates when the auxiliary functions are available in the display. The auxiliary functions require use of the entire display and corresponding switches.

When the **AUX** switch is activated, *AUX* appears in the MODE display and an auxiliary function's name appears in the PATTERN display. The **PATTERN** switch selects the auxiliary function to be modified. The **CATEGORY** and **RESULTS** switches change parameter settings for many of the auxiliary functions. Refer to Section 4 Auxiliary Functions, for more information.



3.3 MAINFRAME—TEST CONNECTIONS

The following connections and switches are used to connect the T-BERD 107A to the circuit being tested. Figure 3-3 illustrates the switches associated with connecting the T-BERD 107A to a circuit. Figure 3-3 illustrates the T-BERD 107A top panel test connections.

- **RX INPUT** switch 7
- **LBO** switch 8
- **RX** jack 9
- **TX** jack 10
- **REF** jack 11
- **VF OUT** jack 12

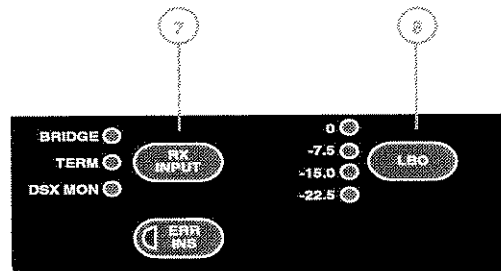

Figure 3-3
Test Connections Related Switches

3.3.1 Test Connection Related Switches

Prior to connecting to the T1 circuit, the T-BERD 107A must be configured to match the type and location of the T1 circuit. The following switches should be set prior to connecting to the T1 circuit (see Figure 3-4).

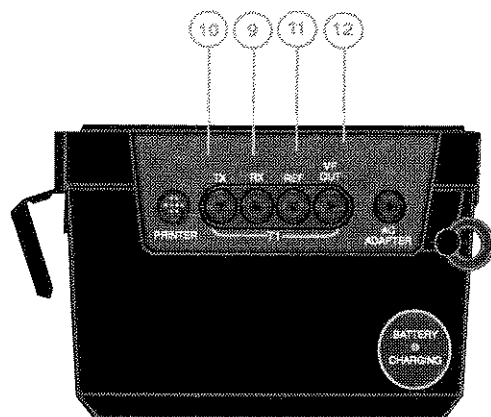

Figure 3-4
Top Panel Test Connections

RX INPUT Switch (7)

This three-position switch selects the input impedance and signal conditioning for the RX jack. A configurable input impedance allows the T-BERD 107A to accommodate signals attenuated by cable loss or resistive circuits. Changing the **RX INPUT** switch position causes a test restart.

BRIDGE— Provides an input impedance greater than $1000\ \Omega$ for bridging lines that are already terminated. The BRIDGE setting provides compensation for cable losses of up to 35 dB. This is useful for bridging across repeater cable pair input and outputs.



TERM— Provides a nominal input impedance of 100 Ω. The TERM setting provides compensation for cable losses of up to 35 dB for T1 lines. This is useful for terminating a circuit with the T-BERD 107A.

DSX-MON — Provides a nominal 100 Ω of input impedance and compensates for resistive loss. The DSX-MON setting is useful for monitoring T1 lines at DSX monitor points which are resistor-isolated.

LBO Switch

This four-position switch provides four different Line Build-Outs (LBO). The LBO values are 0, -7.5, -15, and -22.5 dB and are indicated by the illumination of the appropriate LED. The selected cable loss affects the transmit signal only.

If transmitting directly into the span at the Network Interface Unit (NIU), select the appropriate LBO setting to avoid sending too strong a signal into the first repeater. The LBO value plus the receive level (dBdsx measurement) should range between -15 and -22.5 dB. For example, if the receive level is -10 dBdsx, the LBO should be set to -7.5 dB (-10 + -7.5 = -17.5 dB). If replacing an NIU, the LBO should be set to the same level as the replaced NIU.



3.3.2 Test Connections

The following top panel jacks are used at central office or customer premises test locations (DSX-1 patch panel, distribution frame, NIU, or CSU) to connect to the T1 circuit under test. These jacks can also be used with the T-BERD T1 Repeater Extender to access the T1 circuit at span repeaters.

RX Jack

This bantam jack receives the input signal. Use the **RX INPUT** switch to set the line termination for the connection.

TX Jack

This bantam jack connects the T-BERD 107A transmit output to the circuit under test. Use the **LBO** switch to set the output level. This connector also provides the simplex current path to the RX jack.

REF Jack

This bantam jack provides a connection for a T1 reference clock input for use in timing slips measurements. This jack provides a nominal 1000 Ω termination and accepts resistively attenuated signals over the range +6 to -24 dBdsx.

VF OUT Jack

This 600 Ω bantam jack provides a DS0 or VF signal output to an external TIMS or analog test set for in-depth analysis.



3.4 MAINFRAME — TEST RESULTS

Once the T-BERD 107A is configured and connected to the circuit, use the following switches and indicators to initiate the test and collect the test results. Figure 3-5 illustrates the switches and indicators required to verify the results.

- **RESTART** switch (13)
- **DISPL LIGHT** switch (14)
- **CATEGORY** switch (15)
- **RESULTS** switch (16)
- Status LEDs (17)
- Alarm LEDs (18)
- **HIST RESET** switch (19)
- **SUMMARY** category messages

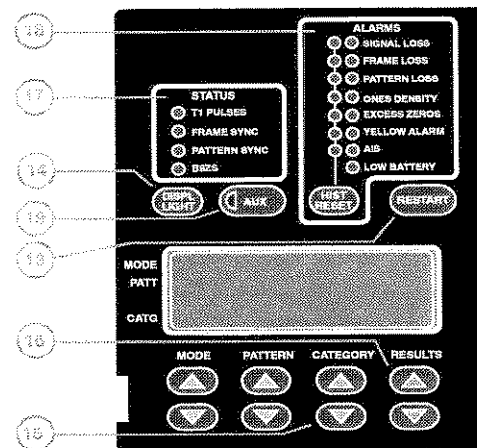

Figure 3-5
Test Results Switches and Indicators

**RESTART Switch** 13

This switch causes a test restart that affects all functions related to the test in progress, such as test results, Status LEDs, and History LEDs. Pressing and holding this switch during power-up clears non-volatile RAM (NOVRAM). Clearing NOVRAM sets all the parameters to their factory default settings as listed in Appendix A.

DISPL LIGHT Switch 14

This switch illuminates the front-panel display for better visibility in low light conditions. When pressed once, the display illuminates for 30 seconds. When pressed twice within 30 seconds, the display illuminates and remains illuminated until the switch is pressed a third time.

CATEGORY Switch 15

This switch selects the test results category. Similar test results are grouped under a category. The categories are SUMMARY, ERRORS, SIGNAL, and TIME. The DATALINK category is available when the SLC Datalink Decode Option is installed. The **CATEGORY** switch consists of up-arrow and down-arrow switches, which scroll through the categories in either direction. The test results categories are discussed in detail in Section 5 Test Results.

RESULTS Switch 

This switch selects the test result displayed within the selected category. The **RESULTS** switch consists of up-arrow and down-arrow switches, which allow the operator to scroll through and display the test results within the selected category. The test results are discussed in detail in Section 5 Test Results.

Collecting Test Results

During a test, the available test results and signal measurements are continuously updated. The test results are divided into four categories. The first and most commonly used category is the SUMMARY category. During the initial test setup procedure, the SUMMARY category displays key non-zero or out-of-specification results. Refer to Section 5 Test Results for more information on the test results. The available categories and results include:

SUMMARY Category

| | |
|-------------|--------------------------------------|
| BITERRORS | Bit Errors |
| VIOLATIONS | Bipolar Violations (BPVs) |
| FRMERRORS | Frame Errors |
| CRCERRORS | Cyclic Redundancy Check (CRC) Errors |
| RXFREQ, Hz | Receive Frequency in Hz |
| TIMING SLIP | Timing Slips |



AIS—Illuminates when 2048 consecutive ones are detected in an unframed format.

Low Battery—Illuminates approximately 15 minutes before the battery is completely drained of power. The battery is recharged as necessary anytime AC power is applied. For a full charge, recharge the battery for approximately eight hours with the instrument turned off. Refer to Section 2.7 Battery Replacement for additional information.

HIST RESET Switch

Pressing this switch clears all History LEDs. Note that this switch does not restart a test, nor does it affect any of the current LEDs or accumulated test results. The **RESTART** switch also clears the illuminated History LEDs.

SUMMARY Category Messages

The SUMMARY category provides a convenient way to monitor specific results and measurements without having to search through the other categories. The SUMMARY category also provides a number of messages indicating whether the results are in or out of specification.

The SUMMARY category is selected by pressing the **CATEGORY** switch. When the category is selected, the name appears in the CATEGORY display.



During initial acquisition of the received signal, the SUMMARY category should be displayed. The following messages can appear during signal acquisition:

ALL RESULTS OK — Message appears when all summary results are error-free or meet specification boundaries.

ALL RESULTS UNAVAILABLE — Message appears at a test restart when the instrument has not synchronized with the received signal.

When an error is detected, the appropriate test result appears in the RESULTS display. Refer to Section 5 Test Results for more information on the results that appear in the SUMMARY category.

3.5 MAINFRAME — TROUBLESHOOTING CONTROLS

During T1 circuit testing, it is often necessary to determine the location of problems identified through testing. This often involves gathering additional information by sectionalizing the T1 span to isolate the problem. Figure 3-6 illustrates the following troubleshooting controls and indicators that are used to help sectionalize the T1 circuit.

- * LOOP CODES switch (20)
- * LOOP UP switch (21)
- * LOOP DOWN switch (22)
- * Pre-Existing Loop LED (23)
- * ERR INS switch (24)

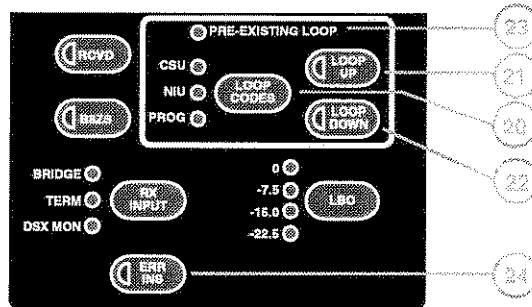

Figure 3-6 Troubleshooting Controls and Indicators

LOOP CODES Switch (20)

This switch selects the type of loop code transmitted and responded to by the T-BERD 107A: CSU, NIU, or PROG. The T-BERD 107A can transmit loop-up and loop-down codes (**LOOP UP** and **LOOP DOWN** switches) to devices that can respond to in-band loop codes or out-of-band (ESF datalink) loop codes. These loop codes enable the T-BERD 107A to establish an out-of-service loopback anywhere along the span. Loop codes can be sent framed or unframed.

The following auxiliary functions are used in conjunction with the **LOOP CODES** switch to determine the loop codes that are transmitted and responded to by the T-BERD 107A (see Section 4 Auxiliary Functions):

AUX PGM LPUP — Programs the programmable loop-up code.

AUX PGM LPDN — Programs the programmable loop-down code.



AUX AUTORESP—Determines if the T-BERD 107A responds to the selected loop code and establishes a loopback.

AUX LOOPCODE — Determines what CSU loop code is transmitted or responded to when the **LOOP CODES** switch is set to CSU, NIU, and PROG.

LOOP UP Switch

This LED switch controls the transmission of the loop-up code. The LED within the **LOOP UP** switch illuminates for the duration of loop code transmission. The switch is disabled in T1 TLB and T1 LLB modes.

To verify the looping of the circuit, observe the Status LEDs for indications of synchronization to the transmitted signal, insert a single error in the transmitted signal, and observe the received signal. If the inserted error does not appear on the received signal, the circuit failed to loop up properly.

When the **LOOP UP** switch is pressed, the following occurs:

- The loop code is continuously transmitted until an appropriate response is detected at the T-BERD 107A receiver, a pre-existing loop is detected, a pre-determined time-out interval of three seconds (out-of-band payload only) is exceeded, any major switch is pressed, or the **LOOP UP** switch is pressed again.



- If an in-band loop code is selected, the transmitted loop code overwrites the selected data pattern and *LOOP UP* appears in the PATTERN display. If an ESF out-of-band loop code is selected, the loop code is transmitted in the datalink and does not overwrite the test pattern.
- The switch LED illuminates while transmitting the loop code.

LOOP DOWN Switch

This LED switch controls the transmission of the loop-down code. The LED within the **LOOP DOWN** switch illuminates for the duration of loop-code transmission. The switch is disabled in T1 TLB and T1 LLB modes.

When the **LOOP DOWN** switch is pressed, the following occurs:

- The loop code is continuously transmitted until an appropriate response is detected at the T-BERD 107A receiver, a pre-determined time-out interval (three seconds for out-of-band payload, 250 milliseconds for out-of-band line) is exceeded, any major switch is pressed, or the **LOOP DOWN** switch is pressed again.
- If an in-band loop code is selected, the transmitted loop code overwrites the selected data pattern and *LOOP DN* appears in the PATTERN display. If an ESF out-of-band loop code is selected, the loop code is transmitted in the datalink and does not overwrite the test pattern.
- The switch LED illuminates while transmitting the loop code.



Pre-Existing Loop LED

This red LED illuminates when a pre-existing loop is detected. The Pre-Existing Loop LED illuminates and remains illuminated for five seconds during an in-band loop-up attempt when an in-band loop-up code is detected within one and a half seconds from the start of loop-up code transmission. When a pre-existing loop is detected, the transmission of the in-band loop-up code is immediately halted, and the **LOOP UP** switch LED is extinguished.

ERR INS Switch

This switch inserts a single logic error and a single BPV into the transmitted data stream each time it is pressed. When performing out-of-service tests, use the **ERR INS** switch to ensure continuity of the system.

Logic errors and BPVs can be inserted in all transmitted signals, except when T1 LLB mode is selected. Logic errors and BPVs are inserted without regard to B8ZS coding sequences. This may cause the same error multiplication (one inserted error causing multiple errors) that occurs on a repeatered span. Errors are randomly inserted on data bits (99.48% probability) and frame bits (0.52% probability). If the inserted error overwrites a data bit while in T1 ESF, it will cause a CRC error.



3.6 MAINFRAME — PRINTER CONTROL

The T-BERD 107A can generate a printout manually or automatically. The printouts provide a hard copy of the test results and the instrument configuration. The print function is controlled through the following auxiliary functions (see Section 4 Auxiliary Functions):

AUX PRINT — Selects the type of printout (results or controls) and initiates the printout.

AUX BUF CLR — Clears the print buffer of all stored printouts.

AUX PRI INTV — Determines the time interval between automatic results printouts during a timed test.

AUX PRI EVNT — Selects the type of event that automatically generates a results printout.

The following connector is used to generate printouts.

PRINTER Connector

This female, 8-pin DIN-type connector serves as the RS-232 printer interface connector. It is configured with DCE pinouts to connect the T-BERD 107A to the PR-40A or compatible printer. The connector interface is configured with the following auxiliary functions (see Section 4 Auxiliary Functions):

AUX PRNTPORT — Sets the interface parameters. BAUDRATE selections are 300, 1200, 2400, 4800, and 9600. PARITY selections are NONE, ODD, and EVEN. TERM 232 selections are CR (Carriage return) and CRLF (Carriage Return-Linefeed).



SLC DATALINK DECODE OPTION

Introduction

Test Setup

Test Results

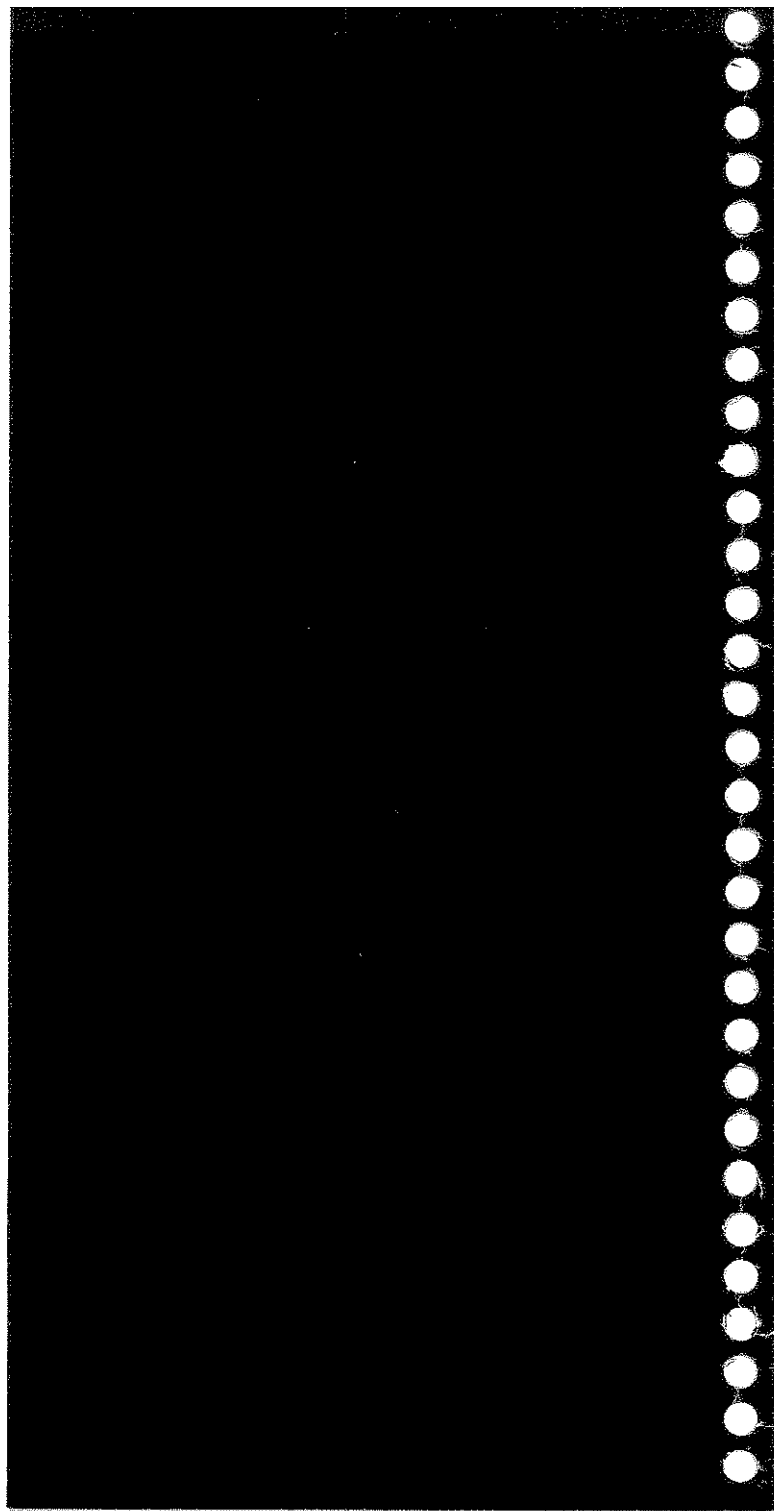



3.7 SLC DATALINK DECODE OPTION — INTRODUCTION

The SLC Datalink Decode Option (107A-1) provides the T-BERD 107A with the ability to monitor and report on the SLC Mode 1 and SLC Mode 2 datalink. This option adds the DATALINK category with two SLC datalink alarm results. In addition, this option enables the T-BERD 107A to display and store SLC datalink alarm and maintenance messages.

NOTE: Unless indicated, the capabilities of the mainframe are applicable to the SLC Datalink Decode Option.

3.8 SLC DATALINK DECODE OPTION — TEST SETUP

MODE Switch

The following modes are added to the operating mode selections in place of the standard T1 SLC mode.

SLC-M1 — SLC-Mode 1 mode configures the T-BERD 107A to monitor the SLC-Mode 1 datalink on SLC-96 circuits.

SLC-M2 — SLC-Mode 2 mode configures the T-BERD 107A to monitor the SLC-Mode 2 datalink on SLC-96 circuits.



3.9 SLC DATALINK DECODE OPTION — TEST RESULTS

CATEGORY Switch

In addition to the four standard mainframe categories, the following category is added to the switch selections.

DATALINK — The DATALINK category includes the SLC Alarm Seconds and Alarm Field Size test results that are taken from the SLC datalink signal.

Collecting Test Results

With the SLC Datalink Decode Option installed, the test results are divided into five categories. The test results in each selected category are displayed by pressing the **RESULTS** switch. Following are the additional category and results.

SUMMARY Category

| Current Alarm Messages | Definition |
|------------------------|---|
| MAJOR ALARM SHELF x | Major Alarm and a Shelf x Alarm (x = A, B, C, or D) |
| MAJOR ALARM NO SHELF | Major Alarm Without a Shelf Alarm |
| ALARM SHELF x | Alarm Shelf x Without a Major Alarm (x = A, B, C, or D) |
| FE LOOP SHELF x | Far-End Loop on Shelf x (x = A, B, C, or D) |
| FE LOOP PROTECT | Far-End Loop on Protection Line |
| SHELF x ON PROT | Shelf x on Protection Line (x = A, B, C, or D) |
| MINOR ALARM | Minor Alarm |
| PWR/MISC ALARM | Power/Miscellaneous Alarm |
| MAINT HOOK/SEIZE | On-Hook/Seize Maintenance Message |
| MAINT PROCEED | Proceed Maintenance Message |
| MAINT TEST ALARM | Test Alarm Maintenance Message |
| DATALINK SYNC LOSS | Datalink Synchronization |
| NO DATALINK SYNC | No Datalink Synchronization |



DATALINK Category

| | |
|-------------------------------|---|
| Test Result | Definition |
| SLCALMSEC | SLC Alarm Seconds |
| ALMFIELD | SLC Alarm Field Size |
| History Alarm Messages | Definition |
| MAJOR ALARM SHELF x | Major Alarm and a Shelf x Alarm (x = A, B, C, or D) |
| MAJOR ALARM NO SHELF | Major Alarm Without a Shelf Alarm |
| ALARM SHELF x | Alarm Shelf x Without a Major Alarm (x = A, B, C, or D) |
| FELoop SHELF x | Far-End Loop on Shelf x (x = A, B, C, or D) |
| FELoop PROTECT | Far-End Loop on Protection Line |
| SHELF x ON PROT | Shelf x on Protection Line (x = A, B, C, or D) |
| MINOR ALARM | Minor Alarm |
| PWR/MISC ALARM | Power/Miscellaneous Alarm |
| MAINT HOOK/SEIZE | On-Hook/Seize Maintenance Message |
| MAINT PROCEED | Proceed Maintenance Message |
| MAINT TEST ALARM | Test Alarm Maintenance Message |





**ADVANCED STRESS PATTERNS
OPTION**

Introduction

Test Setup

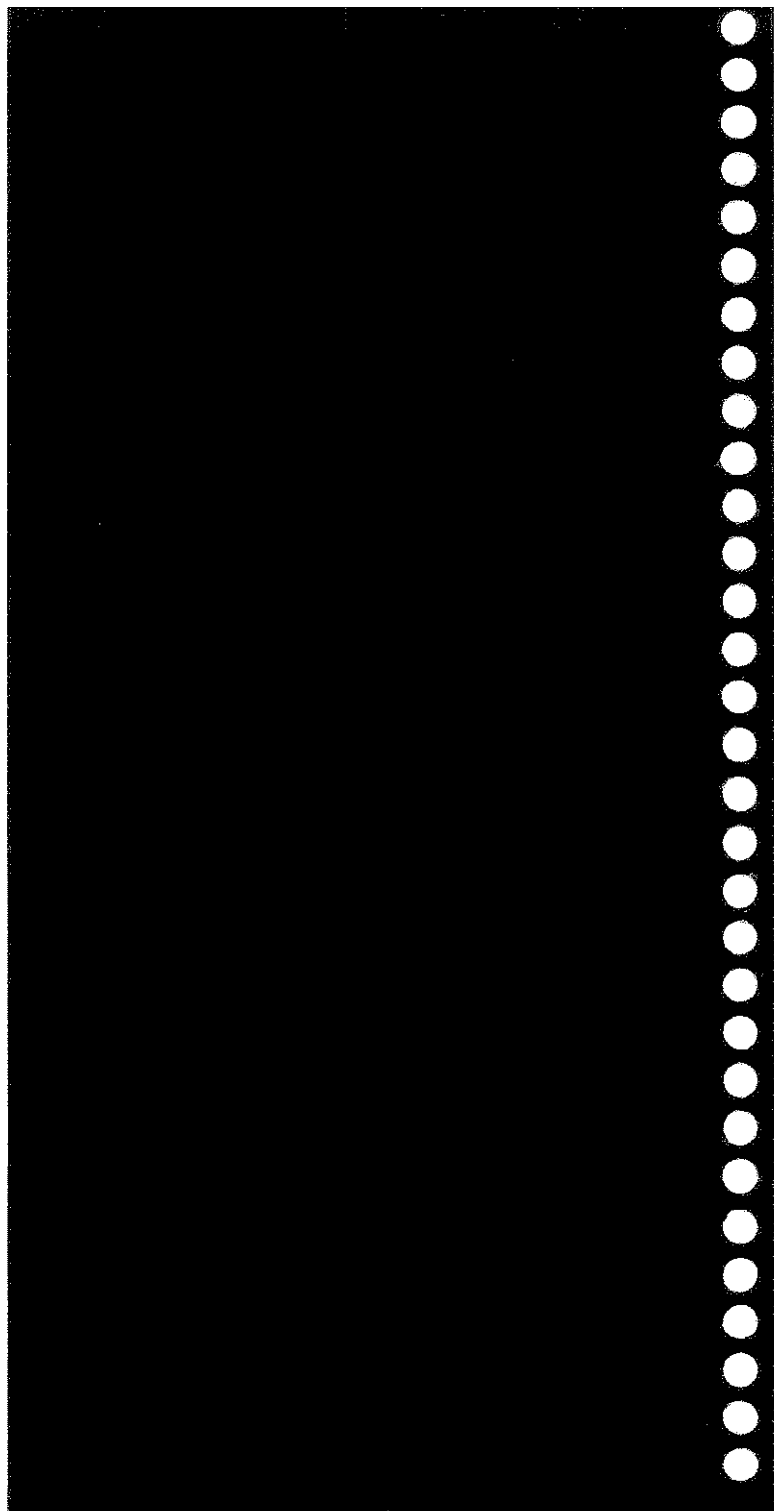



3.10 ADVANCED STRESS PATTERNS OPTION — INTRODUCTION

The Advanced Stress Patterns Option (107A-2) adds seven T1 stress patterns to the T-BERD 107A. The seven T1 stress patterns are designed to stress test the timing recovery circuits and span-line repeater ALBO circuitry.

NOTE: Unless indicated, the capabilities of the mainframe are applicable to the Advanced Stress Patterns Option.

3.11 ADVANCED STRESS PATTERNS OPTION — TEST SETUP

PATTERN Switch

In addition to the standard mainframe test patterns, the Advanced Stress Patterns Option adds the following T1 stress patterns. Unless otherwise indicated, these patterns can be transmitted framed or unframed. See Appendix C for the bit and hexadecimal patterns.

T1 DALY — This 55-octet pattern has one byte different than the 55 OCTET pattern. This change enables the pattern to meet ones density and maximum zeros criteria.

T1-2/96 — This 96-octet pattern can be used to detect faulty M12 cards in DS3 equipment. The pattern consists of a long series of high ones



density octets followed by quick changes from average ones density to low ones density octets. When the pattern is frame aligned, it provides a SUmaximum of 15 zeros and meets the ones density criteria. This pattern causes false frame synchronization on D4-type framed circuits.

T1-3/54 — This 54-octet pattern can be used to stress test repeater pre-amplification, equalization, and automatic line build-out (ALBO) circuitry. The pattern consists of rapid transitions from low ones density to high ones density octets. When the pattern is frame aligned, it exceeds the maximum zeros criteria and should only be transmitted over the repeatered span and not the network.

T1-4/120 — This 120-octet pattern can be used to stress test equalization circuits between T1 multiplexers. This pattern is similar to the T1-2/96 pattern and consists of rapid changes from high ones density to minimum ones density octets. When the pattern is frame aligned, it contains a maximum of seven zeros and meets the ones density criteria.

T1-5/53 — This 53-octet pattern can be used to stress test repeater equalization circuits and automatic line build-out (ALBO) circuitry. The pattern consists of rapid transitions from high ones density octets to low ones density octets. When the pattern is frame aligned, it does not exceed the maximum zeros criteria, but it does exceed the $8(n+1)$ ones density criteria. The pattern should only be transmitted over the repeatered span and not the network.



55 OCTET — This 55-octet pattern can be used to stress test repeater timing recovery and ALBO circuitry. The pattern consists of rapid transitions from high ones density octets to low ones density octets. When the pattern is frame aligned, it violates the maximum zeros and ones density criteria. The pattern should only be transmitted over the repeatered span and not the network.

MIN/MAX — This 72-octet minimum/maximum density pattern can be used to stress test repeater pre-amplification, equalization, and ALBO circuitry. The pattern consists of rapid transitions from low ones density to high ones density octets. When the pattern is frame aligned, it meets the maximum zeros and ones density criteria.





ENHANCED ESF OPTION

Introduction

Test Setup

Test Results

Printer Control

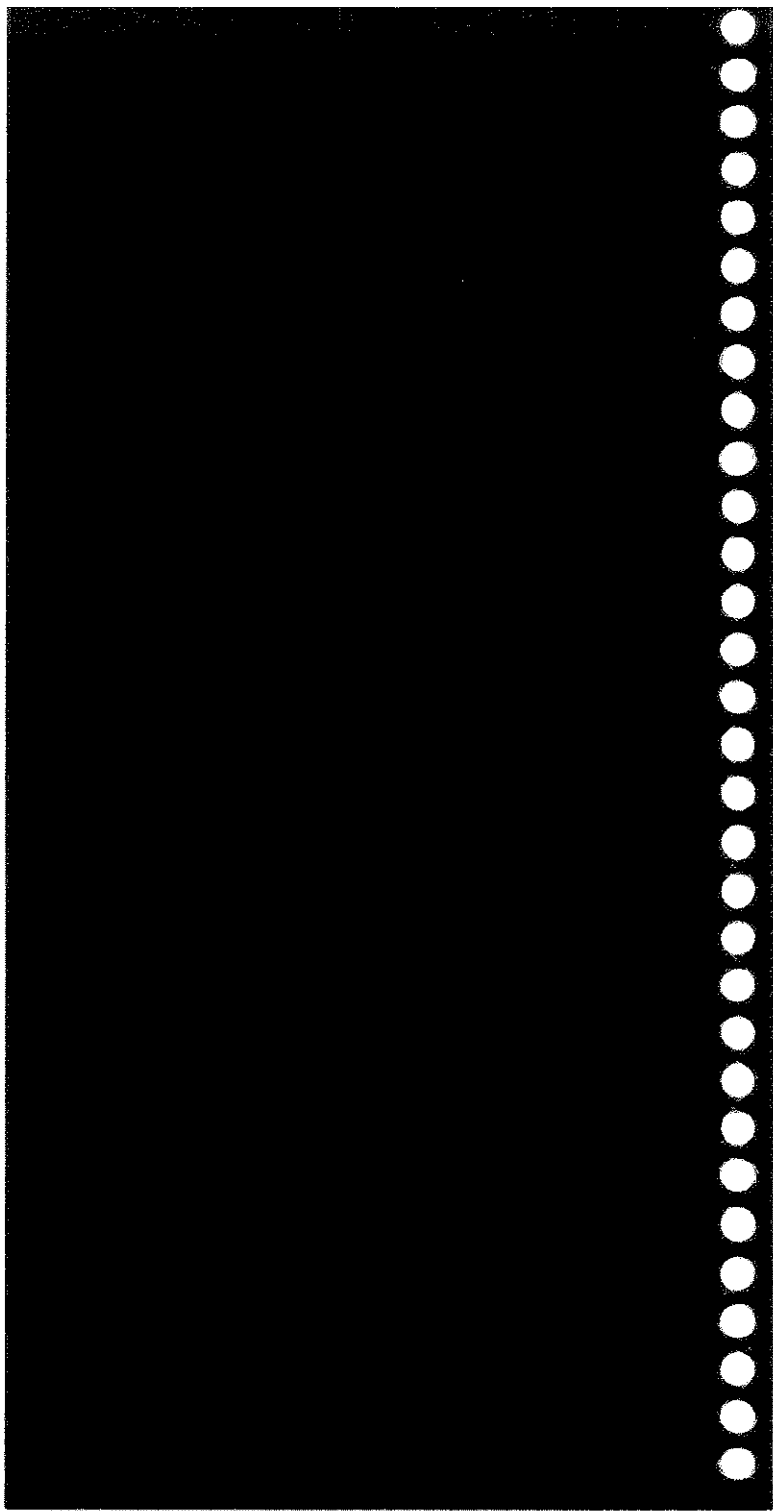



3.12 ENHANCED ESF OPTION — INTRODUCTION

The Enhanced ESF Option (107A-3) provides the comprehensive and advanced test capabilities required for installing and maintaining ANSI T1.403 ESF circuits. This option provides monitor and emulation capabilities of the one-second broadcast of Performance Report Message (PRM), per the ANSI T1.403 specification.

The Enhanced ESF Option also adds the SMARTNIU operating mode, which provides access to the T1 span performance statistics recorded by the Westell 3114-40, -50, or -90 NIU/Performance Monitor. This operating mode also supports the Clear Results and Set Clock features of the NIU/Performance Monitor.

NOTE: Unless indicated, the capabilities of the mainframe are applicable to the Enhanced ESF Option.

3.13 ENHANCED ESF OPTION — TEST SETUP

MODE Switch

In addition to the standard mainframe operating modes, the following modes are added to the switch selections:

SMARTNIU — Smart NIU/Performance Monitor mode configures the T-BERD 107A to query the Performance Monitor portion of the Westell



combined NIU/Performance Monitor equipment for the T1 span statistics it recorded. When this mode is enabled, all unrelated functions are disabled, framing is set to T1 ESF, and the transmitted pattern is set to 1:1. The SMARTNIU mode enables three functions; Query, Clear Results, and Set Clock.

PATTERN Switch

When the SMARTNIU mode is enabled, the following switch selections are available:

RESULTS — The RESULTS position activates the Query function of the SMARTNIU mode, which queries, retrieves, and stores the performance monitor statistics. When RESULTS is selected, the **RCVD**, **LOOP CODES**, **LOOP UP**, **LOOP DOWN**, and **ERR INS** switches are disabled. One complete set of performance monitor statistics can be stored at a time, so previously stored statistics are cleared from the T-BERD 107A by the next query.

SETUP — The SETUP position allows the T-BERD 107A to either clear the recorded statistics from the NIU/Performance Monitor or set the NIU/Performance Monitor time and date to match the T-BERD 107A's time and date. The Clear Results function is performed after the results are retrieved using the CLEAR NIU selection. The Set Clock function is performed using the SET CLOCK position.



Auxiliary Functions

The following auxiliary function controls the setup and operation of the Enhanced ESF Option (see Section 4 Auxiliary Functions):

AUX DATALINK — When the Enhanced ESF Option is installed, this auxiliary function is used to select the PRM transmit emulation mode and to determine whether or not the T-BERD 107A will display PRMs, as well as to determine whether or not the T-BERD 107A will display BPMs and to program eight-bit BPM commands.

3.14 ENHANCED ESF OPTION — TEST RESULTS

RESTART Switch

When the T-BERD 107A is in the SMARTNIU mode, regardless of whether the SETUP window or RESULTS window is displayed, pressing the **RESTART** switch activates the Query function and retrieves the T1 span performance statistics from the NIU/Performance Monitor. The T-BERD 107A displays the PIR result for both directions (AZ and ZA) and periodically flashes the following message.

QUERY IN PROGRESS/### OF nnn RECEIVED — indicates the Query function is continuing and has retrieved a portion of the total messages stored in the NIU/Performance Monitor, where ### is the number of messages retrieved and *nnn* is the number of total messages stored in the NIU/Performance Monitor.



When the Query function stops, the T-BERD 107A displays the PIR result for both directions (AZ and ZA) and periodically flashes one of the following messages to indicate the results:

QUERY COMPLETE/ALL DATA OK—indicates Query function is complete with no errors reported.

QUERY COMPLETE/ERRORS DETECTED—indicates Query function is complete with one or more errors reported.

QUERY FAILURE/NO DATA AVAILABLE—indicates the Query function failed with no data retrieved. Query failure was caused by loss of signal, loss of frame, excessive re-transmission of a message, timeout of a response to a query message, or loss of power.

QUERY FAILURE/PARTIAL DATA OK—indicates the Query function failed with some messages retrieved. The retrieved data reported no errors. Query failure was caused by loss of signal, loss of frame, excessive re-transmission of a message, timeout of a response to a query message, or loss of power.

QUERY FAILURE/ERRORS DETECTED—indicates the Query function failed with some messages retrieved. The retrieved data included error messages. Query failure was caused by loss of signal, loss of frame, excessive re-transmission of a message, timeout of a response to a query message, or loss of power.



CATEGORY Switch

When the T-BERD 107A is in the SMARTNIU mode with the SETUP position selected, pressing the **CATEGORY** switch activates the Set Clock function. The message *SET CLOCK IN PROGRESS* is displayed for approximately ten seconds. When the Set Clock function stops, the T-BERD 107A displays one of the following messages to indicate the results.

SET CLOCK FAILED — indicates the Set Clock function failed to set the time and date to match the T-BERD 107A's time and date. This could be the result of poor connections. Check the T1 circuit connections and try again.

CLOCK SET — indicates the Set Clock function has set the NIU/Performance Monitor time and date to match the T-BERD 107A's time and date.

RESULTS Switch

When the T-BERD 107A is in the SMARTNIU mode with the SETUP position selected, pressing the **RESULTS** switch activates the Clear Results function of the NIU/Performance Monitor. The message *CLEAR NIU IN PROGRESS* is displayed for approximately ten seconds. When the Clear Results function stops, the T-BERD 107A displays one of the following messages to indicate the results.

CLEAR NIU FAILED — indicates the Clear Results function failed to clear the NIU/Performance Monitor of all messages. This could be the result of poor connections. Check the T1 circuit connections and try again.

NIU CLEARED — indicates all results are cleared from the NIU/Performance Monitor.

Collecting Test Results

When in the T1 ESF or FT1 ESF modes, the ESF datalink far-end PRM results enable the T-BERD 107A to monitor and report on the status of the ESF datalink PRM as described in the ANSI T1.403-1989 standard. The far-end PRM results appear in the DATALINK and SUMMARY categories and include:

| | |
|--------------|--|
| PRM TIME | Received Performance Report Time |
| FAR FRM ES | Far-End Frame Error Seconds |
| FAR FRM SES | Far-End Severely Errored Framing Seconds |
| FAR BPV SEC | Far-End BPV Seconds |
| FAR SLP SEC | Far-End Controlled Slip Seconds |
| FAR PRM SEC | Far-End Performance Report Seconds |
| FAR CRC ERR | Far-End CRC Error Events |
| FCRC 1 | Far-End CRC Bin 1 |
| FCRC 2-5 | Far-End CRC 2 to 5 Bin (Bin 2) |
| FCRC 6-10 | Far-End CRC 6 to 10 Bin (Bin 3) |
| FCRC 11-100 | Far-End CRC 11 to 100 Bin (Bin 4) |
| FCRC 101-319 | Far-End CRC 101 to 319 Bin (Bin 5) |
| FCRC >319 | Far-End CRC 319 to 333 Bin (Bin 6) |
| PAY SRC | Far-End Payload Source/Loopback |



The far-end PRM results are available when the ESF operating mode is selected and the AUX DATALINK function PRMRCVR is ON. The far-end PRM results are also available in the AUTO LLB and T1 LLB modes.

In the SMARTNIU mode, the NIU/Performance Monitor stored statistics can be retrieved, but they can not be displayed in the RESULTS display. Only the Performance Indication Ratios are displayed as percentage values representing the overall performance of the circuit in each direction.

| MODE | SMARTNIU | PIR | |
|------|----------|-----|----|
| PATT | RESULTS | AZ | ZA |
| | | 100 | 94 |
| CATS | | <91 | 97 |

| MODE | PATTERN | CATEGORY | RESULTS |
|------|---------|----------|---------|
| | | | |
| | | | |

The retrieved data is only available as a Smart NIU Results printout. The T1 circuit is monitored in both directions, and the results are stored as either AZ (CO to NIU) or ZA (Customer to NIU). The statistics are recorded and identified as follows:

CVL — Line Coding Violations is a count of bipolar violations that are not part of a B8ZS sequence.

ESL — Line Errored Seconds is a count of seconds in which at least one CVL has occurred.



SESL — Line Severely Errored Seconds is a count of seconds in which 1544 or more CVLs have occurred (corresponds to a bit error rate of $10E-3$).

UASL — Line Unavailable Seconds is a count of seconds that a line was unavailable. A line is unavailable when ten or more consecutive SESLs occur.

CVP — Path Coding Violation is a count of CRC-6 errors or frame errors.

ESP — Path Errored Seconds is a count of seconds in which at least one CVP has occurred.

SESP — Path Severely Errored Seconds is a count of seconds in which 330 or more CVPs or eight or more frame errors have occurred.

UASP — Path Unavailable Seconds is a count of seconds that a line was unavailable. A line is unavailable when ten or more consecutive SESPs occur.

PDVS — Pulse Density Violation Seconds is a count of seconds in which 16 consecutive zeros have occurred (8 consecutive zeros for B8ZS encoding).

B8ZS — B8ZS Violation Seconds is a count of seconds in which a B8ZS code is detected on a non-B8ZS circuit. This parameter is not valid on B8ZS circuits.



MSEC — Monitored Seconds is a count of seconds in which valid performance information is recorded.

STAT — Status Register is an eight-bit register with the following bits: Bit 1 - Loopback Request, Bit 2 - Data Incomplete Indicator, Bit 3 - Loss of Signal Indicator, Bit 5 - Loss of Power, Bit 6 - Alarm Indication Signal (AIS), Bit 7 - Yellow Alarm, and Bit 8 - Out-of-Frame.

PIR — Performance Indication Ratio is a percentage providing a “quick glance” indication of the performance of the span. The closer the number is to one-hundred, the better the performance.

3.15 ENHANCED ESF OPTION — PRINTER CONTROL

PRINT Switch

When in SMARTNIU mode, press the **PRINT** switch RESULTS position to generate a SMART NIU results printout. The printout lists the statistics retrieved from the NIU/Performance Monitor at the end of a standard results printout. A complete SMART NIU results printout will list recorded results for the current hour (CURRENT HOUR), each of the previous 23 hours (HISTORY HOUR 01 through HISTORY HOUR 23), the current day (CURRENT DAY), and the previous week (HISTORY DAY 01 through HISTORY DAY 07) in the format that follows.



SMART NIU RESULTS DATA COLLECTED

AT:

13:1408-27-93

Key for STAT res.

1 = Looped Back
 2 = Data Incomplet
 3 = Loss of Signal
 4 = Unused
 5 = Power Loss
 6 = AIS
 7 = Yellow Alarm
 8 = Out of Frame

AZ-PIR EFS: 100% AZ-PIR STAT:

<=91%

ZA-PIR EFS: 100% ZA-PIR STAT:

<=91%

CURRENT HOUR 13:00 08-27-93

AZ-CVL : 1372261 AZ-ESL : 14

AZ-SESL: 0 AZ-UASL: 0

AZ-CVP : 1372261 AZ-ESP : 14

AZ-SESP: 0 AZ-UASP: 0

AZ-PDVS: 0 AZ-B8ZS: 0

AZ-MSEC: 0 AZ-STAT: 21

ZA-CVL : 358367 ZA-ESL : 3518

ZA-SESL: NA ZA-UASL: NA

ZA-CVP : 356959 ZA-ESP : 0

ZA-SESP: NA ZA-UASP: NA

ZA-PDVS: NA ZA-B8ZS: NA

ZA-MSEC: NA ZA-STAT: NA

HISTORY HOUR 01 12:00 08-27-93

AZ-CVL : 0 AZ-ESL : 08

.

.

.



3.16 SMART LOOPBACK/COMMAND CODES OPTIONS — INTRODUCTION

The Intelligent Network Support Option (107A-4) enables the T-BERD 107A to loop up and loop down intelligent T1 repeaters.

3.17 SMART LOOPBACK/COMMAND CODES OPTIONS — TEST SETUP

AUX Switch

The Intelligent Network Support Option adds the AUX SMARTNET function, which allows you to select specific intelligent repeater types by manufacturer and model. It also adds a number of intelligent network equipment loop codes to the selections of the AUX LOOPCODE function. For more information, refer to Section 4.2 Auxiliary Functions.

The following auxiliary functions are affected by or have an affect on the Intelligent Network Support Option (see Section 4).

AUX LOOPCODE — When intelligent network equipment is selected in the AUX SMARTNET function, the loop code type and address (if applicable) are selected from the AUX LOOPCODE function.

**3.18 SMART LOOPBACK/COMMAND
CODES OPTIONS
—TROUBLESHOOTING**

LOOP CODES Switch

In the PROG position, this switch enables you to send user-programmable loop codes to loop up or loop down intelligent repeaters. The loop code is determined by the AUX LOOPCODE and AUX SMARTNET functions. For more information, refer to Section 4.2 Auxiliary Functions.



3.19 FRACTIONAL T1 (FT1) OPTION — INTRODUCTION

The Fractional T1 (FT1) Option (107A-5) provides fractional T1 modes for contiguous and noncontiguous, 56KxN and 64KxN, FT1 testing capabilities in D4, and ESF framing formats.

It also provides three FT1 stress patterns (63, 511, and 2047) for testing DDS and fractional T1 circuits. The FT1 Option replaces the 1000 Hz pattern with four VF tones for insertion on single DS0 channels within the DS1 signal.

NOTE: Unless indicated, the capabilities of the mainframe are applicable to the FT1 Option.

3.20 FRACTIONAL T1 (FT1) OPTION — TEST SETUP

MODE Switch

In addition to the mainframe operating modes, the following FT1 operating modes are also available:

FT1 D4 — D4 Superframe Fractional T1 mode configures the T-BERD 107A to transmit and receive D4 framed FT1 data. The FT1 D4 mode is compatible with the D4 superframe format.

FT1 ESF — Extended Superframe Fractional T1 mode configures the T-BERD 107A to transmit and receive ESF framed FT1 data.



Auxiliary Functions

In addition to the standard mainframe auxiliary functions, the following auxiliary functions are added to the T-BERD 107A (see Section 4).

AUX FT1 CHAN — The Fractional T1 Channel Bandwidth auxiliary function selects the FT1 channel bandwidth being tested in FT1 circuits.

AUX FT1 RATE — The Fractional T1 Channel Rate auxiliary function sets the FT1 channel rate.

AUX FT1 IDLE — The Fractional T1 Idle Code auxiliary function sets the FT1 idle code.

AUX VF TONE — The Voice Frequency Tone Selection auxiliary function selects the VF frequency and level of the transmitted VF tone. The VF tone is transmitted on only a single channel, which is the channel selected in the AUX VF CHAN function.

The following auxiliary functions are affected by or have an affect on the FT1 Option (see Section 4).

AUX AUTORESP — When operating in the FT1 modes and AUTORESPONSE is enabled, the T-BERD 107A does not respond to in-band loop codes. However, the T-BERD 107A does respond to ESF out-of-band loop codes when configured for FT1 ESF operation. The AUTORESPONSE mode establishes a full bandwidth loopback and bit error rate test.



AUX LOOPCODE — When FT1 modes are selected, the T-BERD 107A sends in-band loop codes within the selected FT1 channel bandwidth. However, the T-BERD 107A does not respond to FT1 in-band loop codes. Out-of-band loop codes are not affected by the FT1 Option.

PATTERN Switch

When an FT1 mode is enabled, the following stress patterns are available:

63 — A 63-bit (2^6-1) pseudorandom pattern that generates a maximum of five sequential zeros and six sequential ones.

511 — A 511-bit (2^9-1) pseudorandom pattern that generates a maximum of eight sequential zeros and nine sequential ones. This pattern is generally used to test DDS and other circuits operating below 9.6 kb/s.

2047 — A 2047-bit ($2^{11}-1$) pseudorandom pattern that generates a maximum of ten sequential zeros and eleven sequential ones. This pattern is generally used to test DDS and other circuits operating between 9.6 and 56 kb/s.

<tone> — The tone frequency selected in the AUX VF TONE function is displayed as a pattern selection. The selection is either 404 Hz, 1004 Hz, 2713 Hz, or 2804 Hz.



When an FT1 mode is enabled, the following stress patterns are affected:

VF Tones — VF tones should not be used when the 56KxN data rate is selected.

BRIDGTAP and MULTIPAT — The BRIDGTAP and MULTIPAT patterns are designed for full T1 bandwidth performance. These patterns should not be used for FT1 testing.

3.21 FRACTIONAL T1 (FT1) OPTION — TROUBLESHOOTING

LOOP UP and LOOP DOWN Switches

When testing FT1 circuits, the T-BERD 107A in-band loop codes are transmitted within the selected FT1 channel bandwidth or in the ESF datalink.

**SECTION
AUXILIARY
FUNCTIONS 4**

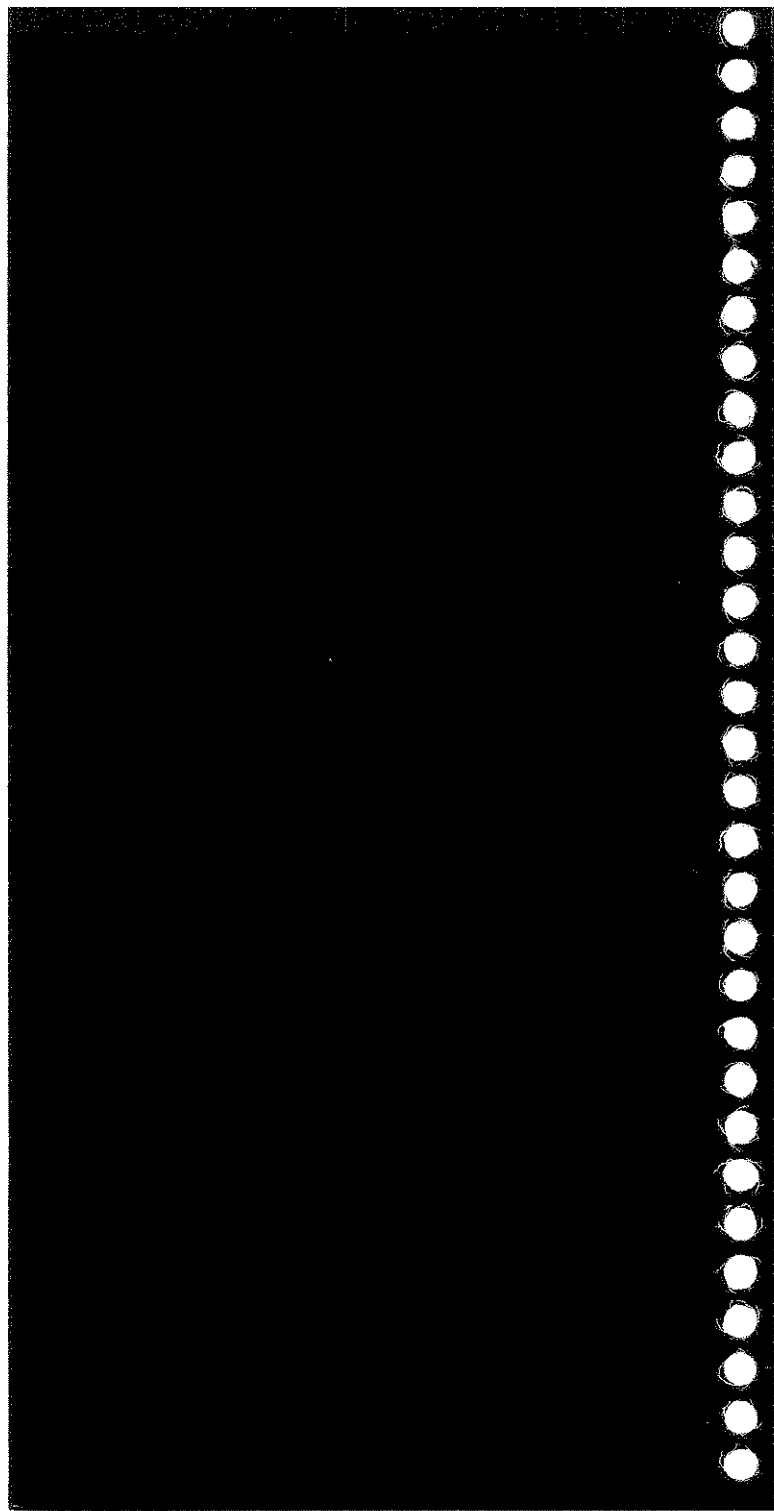



AUXILIARY FUNCTIONS

4.1 INTRODUCTION

Auxiliary functions allow access to parameters that are less frequently used and do not have dedicated switches. When the **AUX** switch is pressed, the LED within the switch illuminates and the character display changes as follows:

- *AUX* appears in the MODE display.
- The last selected auxiliary function appears in the PATTERN display. If this is the first use of the auxiliary functions since a NOVRAM reset or the initial power up of the instrument, *USER1* is displayed.
- The auxiliary function's parameters appear in the RESULTS display.

Once the auxiliary functions are disabled, all the displays return to the previous values.

Table 4-1 lists the available auxiliary functions. The auxiliary functions are described in factory-default order.



Table 4-1
T-BERD 107A Auxiliary Functions

| Auxiliary Function | Description |
|--------------------|---|
| AUX USER1 | User 1 Programmable Test Pattern |
| AUX USER2 | User 2 Programmable Test Pattern |
| AUX USER3 | User 3 Programmable Test Pattern |
| AUX MULTIPAT | MULTIPAT Pattern Selection and Duration |
| AUX DENSITY | Ones Density Alarm Control |
| AUX AUTORESP | Automatic Loop Code Response |
| AUX PGMLPUP | Programmable Loop-Up Code |
| AUX PGMLPDN | Programmable Loop-Down Code |
| AUX LOOPCODE | Loop Code Select |
| AUX SMARTNET | Intelligent Network Equipment Select* |
| AUX DATALINK | ESF Datalink Features Select |
| AUX VFTONE | Voice Frequency Tone** |
| AUX VFCHAN | VF Channel Selection |
| AUX VOLUME | Volume |
| AUX TIME TST | Timed Test |
| AUX TEST LEN | Test Length |
| AUX PRINT | Print |
| AUX BUF CLR | Buffer Clear |
| AUX PRI EVNT | Print Event |
| AUX PRI INTV | Print Interval |

Table 4-1 (Continued)
T-BERO 107A Auxiliary Functions

| Auxiliary Function | Description |
|--------------------|-----------------------------------|
| AUXPRNTPORT | Printer Interface Setup |
| AUXCLOCK | Time and Date |
| AUXFT1 IDLE | Fractional T1 Idle Channel Code** |
| AUXFT1 RATE | Fractional T1 Rate Select** |
| AUXFT1 CHAN | Fractional T1 Channel Select** |

* SmartLoopback/CommandCodes Option required.
** Fractional T1 Option required.

4.2 AUXILIARY FUNCTIONS

AUX USER1, USER2, and USER3 — Programmable Test Patterns

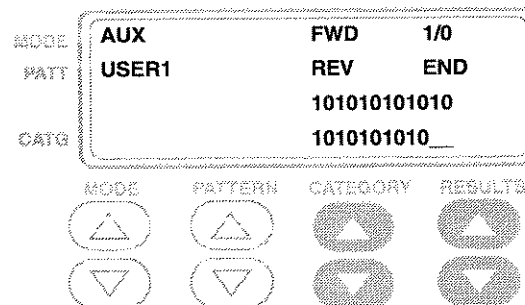



The AUX USER1, AUX USER2, and AUX USER3 functions allow three user-defined 3- to 24-bit patterns to be programmed. These patterns are transmitted when USER1, USER2, or USER3 is selected with the **PATTERN** switch. Each pattern is transmitted from left to right as it is displayed. The factory default settings are 010100100 for the AUX USER1 function, 001101110 for the AUX USER2 function, and 110001110 for the AUX USER3 function.

Use the following procedure to change the pattern setting.

1. **AUX and PATTERN switch**

Press the **AUX** switch to activate the auxiliary functions. Press the **PATTERN** switch to select the AUX USER1 function, AUX USER2 function, or AUX USER3 function.

2. **CATEGORY switch**

Press the up or down arrow to move the cursor (blinking bit) to the bit to be toggled. The up arrow moves the cursor forward (FWD) from left to right. The down arrow moves the cursor in the reverse (REV) direction from right to left.

3. **RESULTS switch**

Press the up arrow to toggle the selected bit (blinking digit) between "1" and "0".

4. **CATEGORY and RESULTS switches**

Repeat Steps 2 and 3 until the desired bit pattern is complete. Move to the last bit of the pattern.



5. RESULTS switch

Press the down arrow to END the pattern at the current bit (blinking digit). Any bits displayed to the right of this bit are deleted.

6. AUX switch

Press the **AUX** switch to return to the operating mode (**AUX** switch LED extinguished).

AUX MULTIPAT — MULTIPAT Pattern Selection and Duration

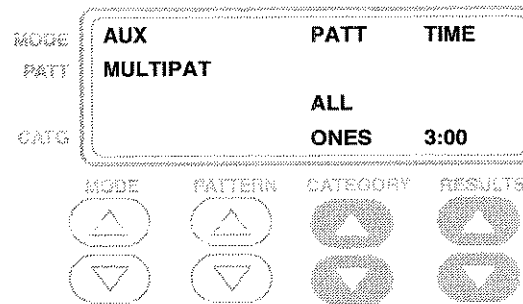

The AUX MULTIPAT function controls the duration of each test pattern of the MULTIPAT test pattern sequence. The test patterns are transmitted when the **PATTERN** switch is set to MULTIPAT.

PATTERN — Press the **CATEGORY** switch to select each of the test patterns: ALL ONES, 1:7, 2 IN 8, 3 IN 24, and T1-QRSS.



TIME — Press the **RESULTS** switch to set the duration of the selected test pattern. The setting 0:00 turns the selected pattern off. For the range 0:00 to 1:00, the duration is set in 15 second steps. For the range of 1:00 to 15:00, the duration is set in one minute steps.

Use the following procedure to change MULTIPAT test pattern duration.

1. **AUX and PATTERN switch**
Press the **AUX** switch to activate the auxiliary functions. Press the **PATTERN** switch to select the AUX MULTIPAT function.
2. **CATEGORY switch**
Press to select ALL ONES, 1:7, 2 IN 8, 3 IN 24, or T1-QRSS.
3. **RESULTS switch**
Press to set the duration of the selected pattern.
4. **AUX switch**
Press the **AUX** switch to return to the operating mode (**AUX** switch LED extinguished).



AUX DENSITY—Ones Density Alarm Control

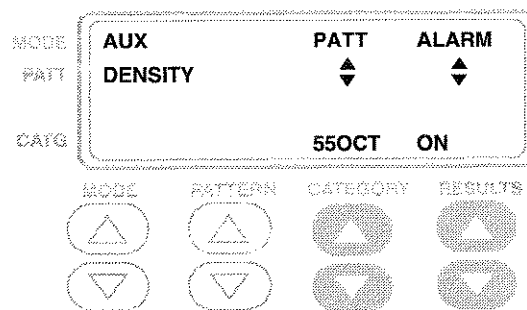

The **AUX DENSITY** function controls the operation of the current and history Ones Density alarm LEDs for the 55 OCTET and 3 in 24 patterns in the framed modes on the T-BERD 107A. When the **AUX DENSITY** function for a pattern is set to ON, the current and history Ones Density LEDs for that pattern function normally. When the **AUX DENSITY** function for a pattern is set to OFF, the current and history Ones Density LEDs for that pattern are suppressed once pattern synchronization is obtained. The current and history Ones Density LEDs might illuminate during pattern synchronization acquisition and extinguish after achieving pattern synchronization.

PATT—Press the **CATEGORY** switch to select the test pattern: 55 OCT or 3 in 24.

ALARM—Press the **RESULTS** switch to toggle the alarm selection between ON and OFF.



Use the following procedure to set the Ones Density alarm status.

1. **AUX and PATTERN switch**
Press the **AUX** switch to activate the auxiliary functions. Press the **PATTERN** switch to select the **AUX DENSITY** function.
2. **CATEGORY switch**
Press to select either **55OCT** or **3 in 24**.
3. **RESULTS switch**
Press to set the Ones Density **LEDs ON** or **OFF**.
4. **AUX switch**
Press the **AUX** switch to return to the operating mode.

AUX AUTORESP — Automatic Loop Code Response

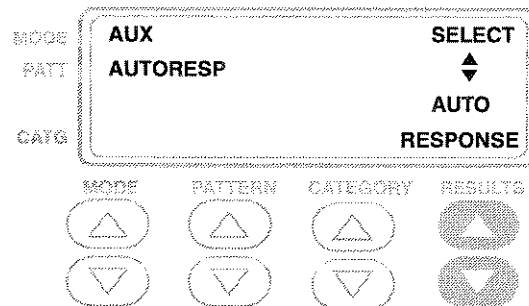



The AUX AUTORESP function determines whether or not the T-BERD 107A enters or leaves automatic line loopback mode (AUTO LLB) in response to received loop codes. Press the **RESULTS** switch to select one of the following:

NO RESPONSE — T-BERD 107A does not respond to received loop codes.

AUTO RESPONSE — T-BERD 107A automatically responds to received loop codes by enabling or disabling the AUTO LLB mode. The instrument only responds to loop codes matching the loop code selected from the AUX CSULoop function or AUX NIULoop function. If the T-BERD 107A is set to T1 TLB or T1 LLB mode, the instrument does not respond to the received loop codes.

When the AUX AUTORESP function is set to AUTORESPONSE, the T-BERD 107A enables the AUTO LLB mode after receiving five seconds of in-band loop-up code or after receiving 250 ms of ESF out-of-band loop-up code. The AUTO LLB mode is disabled after receiving the in-band or ESF out-of-band loop-down code. When AUTO LLB mode is disabled, the instrument returns to the previously selected operating mode. Refer to the **MODE** switch description in Section 3 Instrument Description for more information on the AUTO LLB mode.

Use the following procedure to select a loop code response mode.

1. **AUX and PATTERN switch**

Press the **AUX** switch to activate the auxiliary functions. Press the **PATTERN** switch to select the AUX AUTORESP function.



2. RESULTS switch

Press to select NO RESPONSE or AUTO RESPONSE.

3. AUX switch

Press the **AUX** switch to return to the operating mode (**AUX** switch LED extinguished).

Consider the following auxiliary functions and switch when changing the AUX AUTORESP function:

- ◆ AUX PGMLPUP function
- ◆ AUX PGMLPDN function
- ◆ AUX LOOPCODE function
- ◆ **LOOP CODES** switch

AUX PGM LPUP

— Programmable Loop-up Code

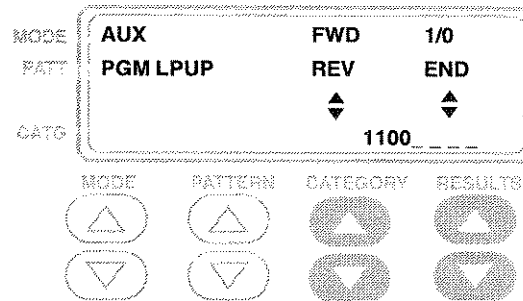

The AUX PGMLPUP function enables a 3- to 8-bit user-defined loop-up code to be programmed. This allows the T-BERD 107A to transmit and respond to non-standard loop codes. The loop code is



transmitted from left to right as displayed. The programmed loop-up code is transmitted when the **LOOP CODES** switch is set to PROG and the **LOOP UP** switch is pressed.

When the T1, T1 D4, T1 D1D, or T1 SLC mode is selected, the loop code is transmitted as an in-band loop code. When the T1 ESF mode is selected, the loop code can be transmitted in-band or out-of-band depending on the AUX CSU LOOP function setting.

Use the following procedure to program the loop code.

1. **AUX and PATTERN switch**

Press the **AUX** switch to activate the auxiliary functions. Press the **PATTERN** switch to select the AUX PGMLPUP function.

2. **CATEGORY switch**

Press the up or down arrow to move the cursor (blinking bit) to the bit to be toggled. The up arrow moves the cursor forward (FWD) from left to right. The down arrow moves the cursor in the reverse (REV) direction from right to left.

3. **RESULTS switch**

Press the up arrow to toggle the selected bit (blinking digit) between "1" and "0".

4. **CATEGORY and RESULTS switches**

Repeat Steps 2 and 3 until the desired loop code is complete. Move to the end of the programmed loop code.

5. **RESULTS switch**

Press the down arrow to END the loop code at the current bit (blinking digit), thereby setting the loop code's length. Any bits displayed after this last bit are deleted.

6. **AUX switch**

Press the **AUX** switch to return to the operating mode (**AUX** switch LED extinguished).

Consider the following auxiliary functions and switches when changing the AUX PGM LPDN function:

- ◆ AUX PGM LPDN function
- ◆ AUX AUTORESP function
- ◆ AUX LOOPCODE function
- ◆ **LOOP CODES** switch
- ◆ **LOOP UP** switch
- ◆ **LOOP DOWN** switch

AUX PGM LPDN
— Programmable Loop-Down Code

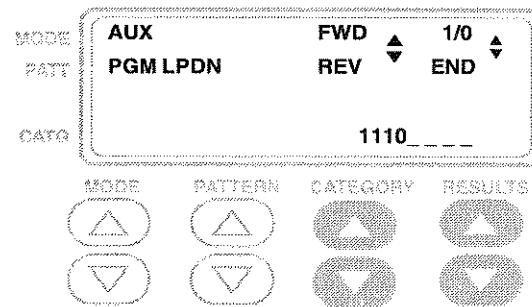



The AUX PGMLPDN function enables a 3- to 8-bit user-defined loop-down code to be programmed. This allows the T-BERD 107A to transmit and respond to non-standard loop codes. The loop code is transmitted from left to right as displayed. The programmed loop-down code is transmitted when the **LOOP CODES** switch is set to PROG and the **LOOP DOWN** switch is pressed.

When the T1, T1 D4, T1 D1D, or T1 SLC mode is selected, the loop code is transmitted as an in-band loop code. When the T1 ESF mode is selected, the loop code can be transmitted in-band or out-of-band depending on the AUX CSU LOOP function setting.

Use the following procedure to program the loop code.

1. **AUX and PATTERN switch**
Press the **AUX** switch to activate the auxiliary functions. Press the **PATTERN** switch to select the AUX PGMLPDN function.
2. **CATEGORY switch**
Press the up or down arrow to move the cursor (blinking bit) to the bit to be toggled. The up arrow moves the cursor forward (FWD) from left to right. The down arrow moves the cursor in the reverse (REV) direction from right to left.
3. **RESULTS switch**
Press the up arrow to TOGGLE the selected bit (blinking digit) between "1" and "0".

4. **CATEGORY and RESULTS switches**
Repeat Steps 2 and 3 until the desired loop code is complete. Move to the end of the programmed loop code.
5. **RESULTS switch**
Press the down arrow to END the loop code at the current bit (blinking digit), thereby setting the loop code's length. Any bits displayed after this last bit are deleted.
6. **AUX switch**
Press the **AUX** switch to return to the operating mode (**AUX** switch LED extinguished).

Consider the following auxiliary functions and switches when changing the AUX PGM LPDN function:

- ✦ AUX PGM LPUP function
- ✦ AUX AUTORESP function
- ✦ AUX LOOPCODE function
- ✦ **LOOP CODES** switch
- ✦ **LOOP UP** switch
- ✦ **LOOP DOWN** switch

AUX LOOPCODE — Loop Codes Select

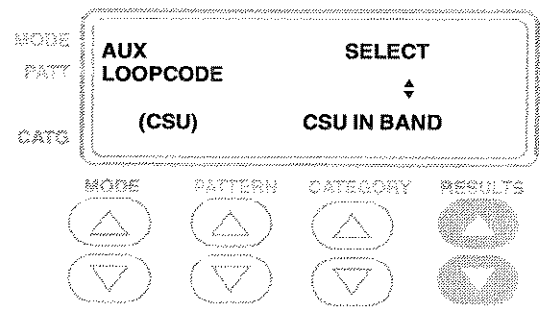



The AUX LOOPCODE function selects the transmitted loop code for the CSU, NIU, and PROG positions of the **LOOP CODES** switch. These selections also determine which loop code causes the T-BERD 107A to establish the AUTO LLB mode. The loop codes are transmitted when the **LOOP UP** or **LOOP DOWN** switch is pressed. The appropriate loop code is transmitted from left to right.

When the **LOOP CODES** switch is in the CSU position, the **RESULTS** switch is used to select one of the following loop codes:

CSU IN BAND — The CSU in-band loop codes are transmitted or responded to in place of the data or test pattern. The in-band loop-up code is 10000. The in-band loop-down code is 100.

ESF LINE — Out-of-band line loop codes are transmitted in the ESF datalink or responded to when received in the ESF datalink. They do not overwrite the data or test pattern. The out-of-band line loop code allows the T-BERD 107A to establish a loopback with a compatible terminal. The loopback affects all data and framing bits. The out-of-band line loop-up code is 1111 1111 0111 0000. The out-of-band line loop-down code is 1111 1111 0001 1100. If this choice is selected when the mode is not an ESF operating mode, the CSU IN BAND loop code is transmitted instead.



ESF PAYLOAD — Out-of-band payload loop codes are transmitted in the ESF datalink. The T-BERD 107A does not respond to an out-of-band payload loop code. The loopback affects only data bits; framing bits are not affected. The out-of-band payload loop-up code is 1111 1111 0010 1000. The out-of-band payload loop-down code is 1111 1111 0100 1100. If this choice is selected when the mode is not an ESF operating mode, the CSU IN BAND loop code is transmitted instead.

When the **LOOP CODES** switch is in the NIU position, the **RESULTS** switch is used to select one of the following loop codes:

FAC1 — The 4-bit facility or network (smart jack) loop codes allow the T-BERD 107A to establish a loopback with a compatible facility interface or respond to a facility loop code. The facility 1 (FAC1) loop-up code is 1100. The facility 1 (FAC1) loop-down code is 1110.

FAC2 — The 5-bit facility or network (smart jack) loop codes allow the T-BERD 107A to establish a loopback with a compatible facility interface or respond to a facility loop code. The facility 2 (FAC2) loop-up code is 11000. The facility 2 (FAC2) loop-down code is 11100.

FAC3 — These facility or network (smart jack) loop codes allow the T-BERD 107A to establish a loopback with a compatible facility interface or respond to a facility loop code. The facility 3 (FAC3) loop-up code is 100000. The facility 3 (FAC3) loop-down code is 100.



ESFNET — The ESF out-of-band network loop codes allow the T-BERD 107A to establish a loopback with a compatible terminal or respond to a network loop code. The ESF out-of-band network loop-up code is 1111 1111 0100 1000. The ESF out-of-band network loop-down code is 1111 1111 0010 0100. If this choice is selected when the mode is not an ESF operating mode, the FAC2 loop code is transmitted instead.

When the **LOOP CODES** switch is in the PROG position, the **CATEGORY** switch is used to select USER, one of the intelligent network equipment codes (Smart Loopback/Command Codes Option required), or ESFDL. The T-BERD 107A does not respond to intelligent network equipment loop codes.

The availability of intelligent network equipment loop codes is determined by the AUX SMARTNET function. If the intelligent network equipment is not selected or is set to NONE in the AUX SMARTNET function, the selection does not appear in the AUX LOOPCODE function. Refer to Appendix D for tables that list the intelligent network equipment, available addresses, and commands. The USER, intelligent network equipment type, and ESF DL selections are described as follows:

USER — The in-band, 3- to 8-bit programmable, loop code settings of the AUX PGM LPUP and AUX PGM LPDN functions are transmitted or responded to by the T-BERD 107A.

IOR— The intelligent office repeater loop codes allow the T-BERD 107A to establish a loopback of an intelligent office repeater. If the intelligent repeater type (see AUX SMARTNET function) has office repeaters that are addressable, the **RESULTS** switch is used to program the address.

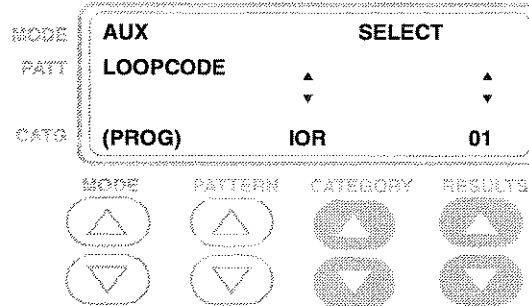

ILR— The intelligent line repeater loop codes allow the T-BERD 107A to establish a loopback of an intelligent line repeater. The **RESULTS** switch is used to program the address.

ILR EXCH — The intelligent line repeater exchange code is used in conjunction with the location code to allow the T-BERD 107A to establish a loopback of an XEL model 7853-000 intelligent line repeater. The **RESULTS** switch is used to program the exchange code. This selection only appears if the AUX SMARTNET function is set to XEL.



ILR LOC — The intelligent line repeater location code is used in conjunction with the exchange code to allow the T-BERD 107A to establish a loopback of an XEL model 7853-000 intelligent line repeater. The **RESULTS** switch is used to program the location code. This selection only appears if the AUX SMARTNET function is set to XEL 7853-000.

IOR CMD or ILR CMD — The intelligent repeater commands allow the T-BERD 107A to activate specific functions of intelligent office and line repeaters. The availability of commands is determined by the type of repeater (see AUX SMARTNET function). The **RESULTS** switch is used to select the command from among the following available commands:

AIS Disable — Disables the automatic AIS transmission for the repeater currently in loopback. Press either the **LOOP UP** or **LOOP DOWN** switch to send the AIS disable code.

Arm/Disarm — Selects the arming/disarming code. An arming code (**LOOP UP** switch) is transmitted down the intelligent repeater span to loop up the NIU and to prepare the intelligent repeaters to loop up or loop down upon receipt of the appropriately addressed loop codes. A disarming code (**LOOP DOWN** switch) loops down the NIU and all the intelligent repeaters on the span.



Auto Learn—Enables the T-BERD 107A to reassign addresses to line repeaters. Pressing the **LOOP UP** or **LOOP DOWN** switch transmits the Auto Learn loop code, which clears all current addresses from the span repeaters. Then, each repeater is automatically assigned a new address based on its position on the span. The first repeater is assigned address 01, the second one is assigned address 02, etc. Each repeater acknowledges its new address by returning an address or address code (bit errors). The process continues until all the repeaters on the span have been assigned a new address (no more address or address codes are received).

Auto Query—Enables the T-BERD 107A to query each line repeater on the span for its address. Pressing the **LOOP UP** or **LOOP DOWN** switch transmits the Auto Query loop code, which sequentially queries each line repeater for its address. The first line repeater responds with its address or an address code (bit errors). If an address code of 555 is displayed, the repeater has no assigned address. The RESULTS display is blanked for approximately five seconds. Then, the second line repeater responds with its address. The address and blank display cycle continues until each line repeater has responded with its address. If the process is interrupted for any reason, the Auto Query loop code must be transmitted again, and the process begins again with the first repeater on the span.



Clear FT1— Sets an office repeater on an FT1 span to full T1 mode temporarily. Either the **LOOP UP** switch or **LOOP DOWN** switch can be used to transmit the Clear FT1 loop code.

CPE Arm — Selects the CPE arming/disarming code. A CPE arming code (**LOOP UP** switch) is transmitted on the intelligent repeater span when testing from the NIU toward the Central Office (CO) to prepare the intelligent repeaters to loop up or loop down upon receipt of the appropriately addressed loop codes. A disarming code (**LOOP DOWN** switch) loops down all the intelligent repeaters on the span.

Dual LPBK— Creates a second loopback of the far-end side of a T1 office repeater that has been programmed for the NIU mode and looped up from the DSX-1 side. The office repeater is placed in dual loopback mode with a loopback toward the CO (DSX-1) and a loopback toward the Customer Premises. Pressing the **LOOP UP** switch transmits the Dual Loopback code. Pressing the **LOOP DOWN** switch transmits the loop-down code that loops down the office repeater.

Far-End NIU Activate — Unblocks an already armed near-end T1 office repeater to allow the appropriate NIU loop code to pass through. Pressing the **LOOP UP** or **LOOP DOWN** switch transmits the unblock code, which allows standard NIU loop up and loop down codes to pass through the office repeater to loop the far-end NIU.



Manual Learn — Enables the 107A to reassign addresses to line repeaters. Pressing the **LOOP UP** switch transmits the Manual Learn loop code, which simultaneously loops back each repeater in the span and prepares each repeater to receive a new address assignment. Select the ILR command and program an address for the first repeater in the span, then press the **LOOP UP** switch to transmit the loop code. The first repeater accepts the loop code, reprograms itself to the new address, and loops itself down, so that the second repeater in the span is ready to receive its new address.

Near-end Arm — Selects the near-end arming/disarming code. A near-end arming code (**LOOP UP** switch) is transmitted on the intelligent repeater span when testing from the NIU toward the Central Office (CO) to prepare the intelligent repeaters to loop up or loop down upon receipt of the appropriately addressed loop codes. A disarming code (**LOOP DOWN** switch) loops down all the intelligent repeaters on the span.

Option Query — Queries for the option status of an intelligent repeater in loopback mode. Press the **LOOP UP** switch to send the option query code. The repeater in loopback first returns its address or an address code, which the T-BERD 107A displays. Then, it returns the status for the repeater options as follows:

Framing Mode — Auto, Dual, or ESF
Loopback Code Detection — Synchronous or Asynchronous



AIS — Enabled or Disabled

CPE Arming Code Block — Enabled or Disabled

Automatic Loopback Timeout — Enabled or Disabled

Repeater Status — Programmed or Original Settings

Power Down — Removes the power from the line past the office receiver while the loop code is being transmitted plus an additional five seconds after the loop code transmission is stopped. Press either the **LOOP UP** or **LOOP DOWN** switch to send the power down code.

Power Loop/Power Query — Queries for and loops up the line repeater that is currently looping back the power. Press the **LOOP UP** switch to send the power loop-up code. Press the **LOOP DOWN** switch to loop down the first repeater on the span that is looped up.

Power Thru — Forces the line repeater that initiated the power loop to return to thru power mode, but it can only be activated from the DSX-1 side of the repeater. Press either the **LOOP UP** or **LOOP DOWN** switch to send the power thru code.

Query — Queries for which line repeater is in loopback mode. The line repeater in loopback returns its address or an address code. Press either the **LOOP UP** or **LOOP DOWN** switch to send the query code.



Sequential Loopback — Loops up and loops down the T1 line repeaters on the span in sequence starting with the repeater nearest the T-BERD 107A and proceeding down the span, regardless of the repeater's address. Pressing the **LOOP UP** switch transmits the Sequential Loopback code. The first time a repeater receives the sequential loop code, it loops up. The second time the sequential loop code is sent, the repeater loops down. Alternatively, the **LOOP DOWN** switch can be used to transmit the loop down code, which loops down the repeater. Regardless of which method is used to loop down the repeater, it ignores all subsequent sequential loop code transmissions until it is disarmed and re-armed.

Time-out Disable/Extend — Disables/extends the loopback timeout function of the repeater. The line repeater loopback should be established first, then the timeout disable function is sent. The timeout function resets when the loopback is deactivated remotely.

IOR PGM ADDR/ILR PGM ADDR — Selects the address change command, which allows the T-BERD 107A to assign an address for the intelligent repeater. Press the **RESULTS** switch to assign the address in the range from 0 to 1999.

IOR PGM CMD, ILR PGM CMD — The remote programming commands allow the T-BERD 107A to activate specific functions of intelligent office repeaters and intelligent line repeaters. Remote programming can only be done from the DSX side while the repeater is in loopback.



Pressing the **LOOP UP** switch transmits the selected programming command to the repeater. The **RESULTS** switch is used to scroll through the command codes:

ACKERROR/ACKINVERSE—Enables the T-BERD 107A to select the acknowledgement type the repeater in loopback uses, the error acknowledgement scheme or the inverted first four bits acknowledgement scheme.

ARM CDE NIU/ARM CDE CPE — Enables the T-BERD 107A to select the arming code the repeater in loopback recognizes, the NIU or the Customer Premises Equipment (CPE) arming codes.

ARMFRM AUTO/ARMFRM DUAL/ARMFRM ESF— Enables the T-BERD 107A to select the framing mode the repeater recognizes.

In Auto Framing mode, the repeater automatically recognizes whether the received framing is ESF or SF framing. When SF framing is detected, the repeater only arms to the in-band arming code. When ESF framing is detected, the repeater only arms to the datalink (out-of-band) arming code.

In Dual Framing mode, the repeater arms to an in-band arming code in both SF and ESF modes. If ESF framing is detected, the repeater also arms to the datalink (out-of-band) arming code.

In ESF mode, the repeater only arms to the datalink (out-of-band) arming code.



AIS ON/AIS OFF— Allows the T-BERD 107A to set the Alarm Indication Signal (AIS) to either ON (enabled) or OFF (disabled). When AIS is enabled, the repeater sends an all ones AIS toward the CPE when the repeater is in loopback.

BLK CPE ON/BLK CPE OFF— Enables the T-BERD 107A to enable or disable the CPE arming code block, which prevents further arming of the span and its elements from the CPE side when the repeater is in loopback.

CDERX ASYNC/CDERX SYNC — Enables the T-BERD 107A to set the code detection, which determines if the repeater responds to asynchronous or synchronous loop codes.

NOTE: The T-BERD 107A always transmits synchronous loop codes.

RESET MSTR/RESET SESN— Allows the T-BERD 107A to reset the programmable features to either the factory default settings (MSTR) or the settings prior to the current loopback session (SESN).

TIMEOUT ON/TIMEOUT OFF — Disables or enables the automatic loopback timeout function of the repeater.

SECTION 4  AUXILIARY FUNCTIONS

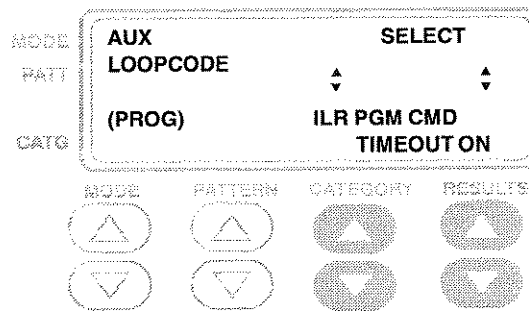

DS1MSW — The DS1 maintenance switch commands allow the T-BERD 107A to activate specific functions of the Westell and Teltrend DS1 maintenance switches. The **CATEGORY** switch is used to select the function:

DS1MSWITCH — The maintenance switch code is used to allow the T-BERD 107A to establish a loopback. The **RESULTS** switch is used to program the address, if applicable.

DS1MSWRAMP — The ramp code is used to allow the T-BERD 107A to connect to the NIU/Performance Monitor on a maintenance switching system without taking the desired DS1 out of service. The **RESULTS** switch is used to program the address, if applicable.

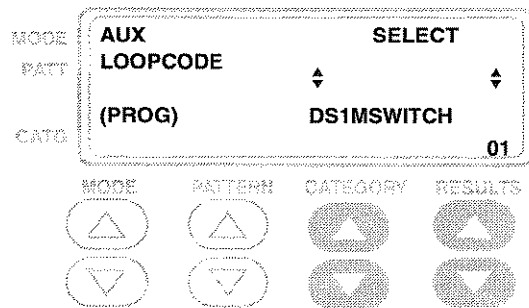

DS1MSCMD— The DS1 maintenance switch commands are used to allow the T-BERD 107A to change the configuration. The **RESULTS** switch is used to select the DS1 maintenance switch command.

Arm/Disarm— Selects the maintenance switch arming/disarming code. An arming code (**LOOP UP** switch) is transmitted down the repeater span to prepare the maintenance switch to loop up or switch a channel upon receipt of the appropriately addressed code.

Query— Reveals if the maintenance switch is in loopback mode. If it is in loopback mode, the switch returns an address code. If is not looped, the switch returns a bit error count of 1350. Press either the **LOOP UP** or **LOOP DOWN** switch to send the query code.

Restore— Loops down the maintenance switch and restores normal operations. Press either the **LOOP UP** or **LOOP DOWN** switch to send the restore code.



Time-out Disable—Disables the loopback timeout function of the maintenance switch. The maintenance switch loopback should be established first, then the timeout disable function is sent. The timeout function resets when the loopback is deactivated remotely.

HDSL — The HDSL loop codes are used to establish a loopback at either the central office or the customer premises. The **RESULTS** switch is used to select between HTU-C (Central office) and HTU-R (Remote - customer premises).

ESF DL — The ESF datalink codes determine which ESF BPMs the T-BERD 107A transmits. Pressing the **LOOP UP** or **LOOP DOWN** switch transmits the selected BPM. When a BPM is being transmitted, its name appears while transmitting in the PATTERN display. The **RESULTS** switch is used to select the BPM command from among the following available commands:

NFSYNC— Do not use for synchronization timing.

STRATUM 1— Stratum 1 traceable timing.

STRATUM 2— Stratum 2 traceable timing.

STRATUM 3— Stratum 3 traceable timing.

STRATUM 4— Stratum 4 traceable timing.

SONET— SONET clock traceable timing.



SYNCUNKNWN—Synchronization quality unknown.

USER—User-programmable BPM.

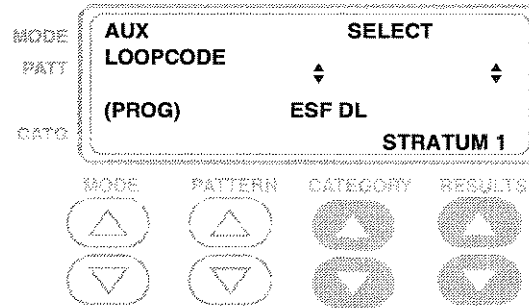

The Smart Loopback/Command Codes Option currently supports the following intelligent network equipment:

- * ADTRAN HTU-C and HTU-R HDSL End Equipment
- * PAIRGAIN HLU-231 and HRU-412 HDSL End Equipment
- * Tellabs HTU-C and HTU-R HDSL End Equipment
- * Teltrend Model IOR7231/ILR7239 Intelligent Repeaters
- * Teltrend Model IOR7231E Intelligent Repeaters
- * Teltrend Model IOR7231LC/ILR7239LC Intelligent Repeaters
- * Teltrend Model IOR7231LD/ILR7239LD Intelligent Repeaters
- * Teltrend Model IOR7231LP/ILR7239LP Intelligent Repeaters



- * Teltrend Model IOR7231LS/
ILR7239LS Intelligent Repeaters
- * Teltrend Model IOR7231LW/
ILR7239LW Intelligent Repeaters
- * Teltrend DS1 Maintenance Switch
System
- * TxPORT Model 231-OR/239-SR Intel-
ligent Repeaters
- * Wescom Smart Span T1 Span Line Sys-
tem with Addressable Bi-Directional
Loopback (F-Series)
- * Westell 3130-56 T1 Office Repeater
with Addressable Loopback Plus
- * Westell 3150-56 T1 Line Repeater with
Addressable Loopback Plus
- * Westell 3151-56 T1 Line Repeater with
Addressable Loopback Plus
- * Westell 3130-70 T1 Office Repeater
with Addressable Loopback Plus
- * Westell 3150-70 T1 Line Repeater with
Addressable Loopback Plus
- * Westell 3130-80 T1 Office Repeater
with Addressable Loopback Plus
- * Westell 3150-80 T1 Line Repeater with
Addressable Loopback Plus
- * Westell 3140-80 T1 Office Repeater
with Addressable Loopback Plus
- * Westell 3150-81 T1 Line Repeater with
Addressable Loopback Plus
- * Westell 3150-CO T1 Line Repeater with
Addressable Loopback Plus
- * Westell 3171 T1 Network Interface and
Maintenance System-20 (NIMS - 12 bit)



- ✦ Westell 3171 T1 Network Interface and Maintenance System-28 (NIMS - 12 bit)
- ✦ Westell 3171 T1 Network Interface and Maintenance System-60 (NIMS - 16 bit)
- ✦ Westell 3224-00/01 HDSL Central Office Terminal Unit (HTU-C)
- ✦ Westell 3222-00/01 HDSL Remote Terminal Unit (HTU-R)
- ✦ XEL 7853-000 Mini T1 Line Repeater
- ✦ XEL 7854-008 Mini T1 Line Repeater

Use the following procedure to select the intelligent network equipment codes.

1. **LOOP CODES switch**
Select the PROG position (LED illuminates).
2. **AUX and PATTERN switch**
Press the **AUX** switch to activate the auxiliary functions. Press the **PATTERN** switch to select the AUX LOOPCODE function.
3. **CATEGORY switch**
Press either the up or down arrow to select the appropriate loop code type.
4. **RESULTS switch**
Press either the up or down arrow to select the specific loop code or intelligent repeater address.
5. **AUX switch**
Press the **AUX** switch to return to the operating mode.



Consider the following functions and modes when sending and receiving loop codes:

- AUXDATALINK function
- AUXPGMLPUP function
- AUXPGMLPDN function
- AUXRESPONSE function
- AUXSMARTNET function
- **LOOP CODES** switch
- **LOOP UP** switch
- **LOOP DOWN** switch

AUX SMARTNET — Intelligent Network Equipment Select

*Smart Loopback/Command Codes
Option Required*

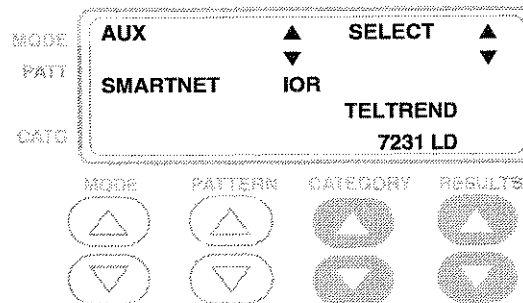

The AUX SMARTNET function selects the intelligent network equipment type by manufacturer and model number, as appropriate. These selections determine what loop codes and commands are available in the AUXLOOPCODE function. This auxiliary function requires the Smart Loopback/Command Codes Option.

When the AUX SMARTNET function is displayed, the **CATEGORY** switch is used to select the intelligent network equipment type, while the **RESULTS** switch is used to select the make/model. All equipment types have a NONE selection for make/model to indicate the equipment is not installed in the network being tested. Refer to Appendix D for tables that list the intelligent network equipment, available addresses, and commands.

Use the following procedure to select the intelligent network equipment type.

1. **AUX and PATTERN switch**
Press the **AUX** switch to activate the auxiliary functions. Press the **PATTERN** switch to select the AUX SMARTNET function.
2. **CATEGORY switch**
Press either the up or down arrow to select the appropriate intelligent network equipment type (IOR, ILR, etc.).
3. **RESULTS switch**
Press either the up or down arrow to select the specific manufacturer and model or NONE, if applicable.
4. **AUX switch**
Press the **AUX** switch to return to the operating mode.

Consider the following functions and modes when selecting an intelligent network equipment type:

- ◆ AUXLOOPCODE function
- ◆ LOOP CODES switch



- LOOP UP switch
- LOOP DOWN switch

AUX DATALINK — ESF Datalink Features Select

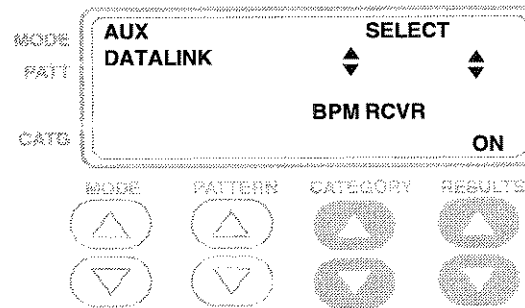

The **AUX DATALINK** function selects whether or not Bit-Patterned Messages (BPMs) are displayed and accumulated. The **AUX DATALINK** function also allows the user to program an eight-bit BPM for reception and transmission. This auxiliary function only has an effect when the TI ESF mode is selected. Press the **CATEGORY** switch to select one of the following:

BPM RCVR — When the BPM receiver is on, the T-BERD 107A decodes the BPM, displays the message in the **RESULTS** display, and adds the BPM results to the Alarms printout. If the BPM receiver is off, the results are not available for display or printout. Press the **RESULTS** switch to toggle the BPM receiver on or off.



USER BPM — The USER BPM position displays an eight-bit number string in the RESULTS II display. The six inner bits can be changed, but the two end bits are always zeros. Press the **RESULTS** switch up arrow to highlight the desired bit. Press the **RESULTS** switch down arrow to toggle the highlighted bit to a one or a zero and automatically advance one bit to the right.

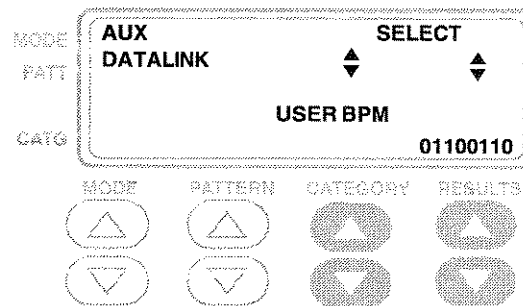

If the Enhanced ESF Option is installed, the AUXDATALINK function is used to select how or if Performance Report Messages (PRMs) are transmitted and whether PRM results are accumulated. Press the **CATEGORY** switch to select one of the following:

PRM TRAN — Press the **RESULTS** switch to select one of the following methods of transmitting the PRM.

EMUL CARR — Emulates the carrier PRM. This selection sets the PRM C/R bit to one.



EMUL CUST— Emulates the customer PRM. This selection sets the PRM C/R bit to zero.

OFF— Disables the PRM transmitter.

PRM RCVR— Press the **RESULTS** switch to toggle the PRM receiver on or off. When the PRM receiver is on, the T-BERD 107A reports on the PRM status in the RESULTS display, and the PRM results appear in the Results printout. If the PRM receiver is off, the results are not available for display or printout.

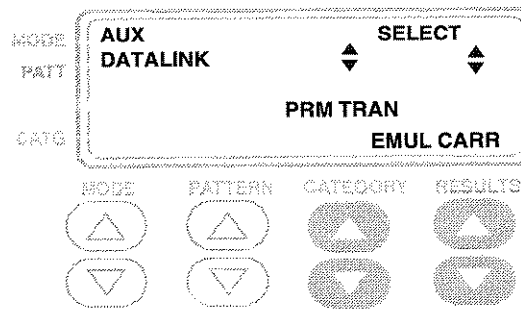

Use the following procedure to select the DATALINK emulation and results availability.

1. **AUX and PATTERN switch**

Press the **AUX** switch to activate the auxiliary functions. Press the **PATTERN** switch to select the AUXDATALINK function.



2. **CATEGORY switch**

Press either the up or down arrow to scroll through the selections (BPMRCVR, USER BPM, PRMTRAN, PRMRCVR). Release the switch when the desired selection is displayed.

3. **RESULTS switch**

Press the appropriate switch (up or down arrow) to select and set the parameters.

4. **AUX switch**

Press the **AUX** switch to return to the operating mode.

AUX VF CHAN

— Voice Frequency Channel Selection

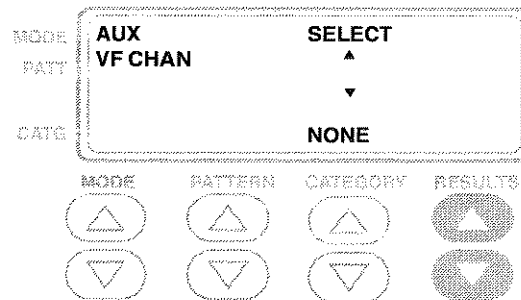

The AUX VF CHAN function allows you to select which of the 24 DS0 channels can be accessed. When the AUX VF CHAN function is selected, the



previously selected channel appears in the RESULTS display. The channel selections are described as follows:

NONE — No DS0 channel will be accessed.

CHANNEL nn — Indicates the channel number (nn is a number from 01 to 24) that will be accessed and available at the RESULTS display, the speaker, and the VF OUT jack, as well as available for insertion.

Use the following procedure to select a DS0 channel to be accessed.

- 1. AUX and PATTERN switch**
Press the **AUX** switch to activate the auxiliary functions. Press the **PATTERN** switch to select the AUX VF CHAN function.
- 2. RESULTS switch**
Press either the up or down arrow to scroll through the choices from NONE to 24. Release the switch to select the channel to be accessed.
- 4. AUX switch**
Press the **AUX** switch to return to the operating mode.

Consider the following auxiliary functions and switch when changing the AUX VF CHAN function:

- AUX VOLUME function
- AUX VF TONE function (if FT1 Option is installed)
- **PATTERN** switch

AUX VOLUME — Speaker Volume

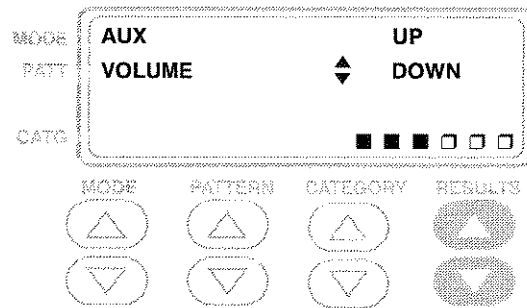

The **AUX VOLUME** function sets the audible output level for the speaker, which also controls the volume of the VF output. A six-box, bar-graph in the **RESULTS** display shows the relative volume by filling in the boxes. The boxes are filled from left to right. If none of the boxes are filled, the speaker is turned off. If all the boxes are filled, the volume is at maximum.

Use the following procedure to change the volume setting.

1. **AUX and PATTERN switch**
Press the **AUX** switch to activate the auxiliary functions. Press the **PATTERN** switch to select the **AUX VOLUME** function.
2. **RESULTS switch**
Press the up arrow (increase) or the down arrow (decrease) to change the volume of the speaker. An audible beep occurs each time the volume is adjusted.

3. **AUX switch**

Press the **AUX** switch to return to the operating mode (**AUX** switch LED extinguished).

The T-BERD 107A provides an audible beep each second one or more bit errors, BPVs, frame errors, CRC errors, or timing slips occur.

AUX TIME TST — Timed Test

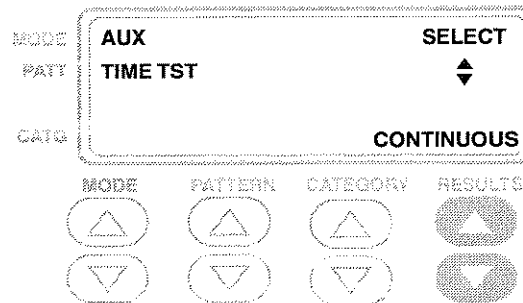

The **AUX TIME TST** function selects either timed or continuous testing, as follows:

TIMED — The T-BERD 107A tests for a limited time determined by the **AUX TEST LEN** function. Changing from continuous to timed testing clears the test results and causes a test restart.



CONTINUOUS — The T-BERD 107A tests continuously. Changing from timed testing to continuous testing during a timed test allows the test to continue (i.e., test results continue to accumulate).

Use the following procedure to select timed or continuous testing.

1. **AUX and PATTERN switch**
Press the **AUX** switch to activate the auxiliary functions. Press the **PATTERN** switch to select the AUX TIME TST function.
2. **RESULTS switch**
Press to select TIMED or CONTINUOUS testing.
3. **AUX switch**
Press the **AUX** switch to return to the operating mode (**AUX** switch LED extinguished).

Consider the following auxiliary functions and TIME category results when changing the AUX TIME TST function:

- ◆ AUXPRIEVNT function
- ◆ AUXPRIINTV function
- ◆ AUXTESTLEN function
- ◆ TESTLENGTH result
- ◆ ELAPSE TIME result
- ◆ TESTENDIN result

AUX TEST LEN
— Timed Test Length Duration

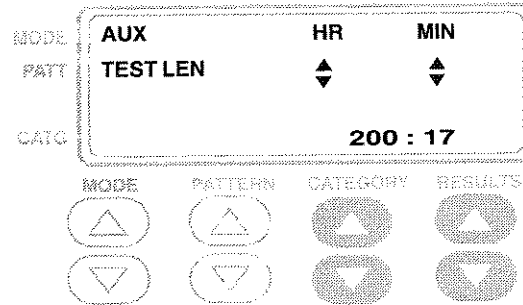

The AUX TESTLEN function sets the length of a timed test. The maximum test length setting is 200 HRS 59 MIN, and the minimum is 0 HRS 1 MIN.

Use the following procedure to set the test length.

1. **AUX and PATTERN switch**
Press the **AUX** switch to activate the auxiliary functions. Press the **PATTERN** switch to select the AUX TESTLEN function.
2. **CATEGORY switch**
Press the up arrow (increase) or down arrow (decrease) to set the hours in one hour increments.
3. **RESULTS switch**
Press the up arrow (increase) or down arrow (decrease) to set the minutes in one minute increments.



4. AUX switch

Press the **AUX** switch to return to the operating mode (**AUX** switch LED extinguished).

Consider the following auxiliary functions and TIME category results when changing the AUX TEST LEN function:

- ◆ AUX PRINTV function
- ◆ AUX TIME TST function
- ◆ TEST LENGTH result
- ◆ ELAPSE TIME result
- ◆ TEST END IN result

AUX PRINT — Print

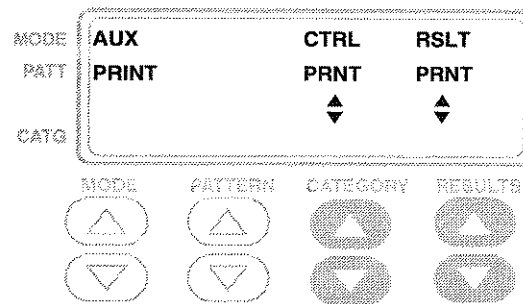

The AUX PRINT function generates either a controls or results printout. If a printer is not attached the printout is stored in NOVRAM. Printout memory storage is limited.



Use the following procedure to generate the desired printout.

1. **AUX and PATTERN switch**

Press the **AUX** switch to activate the auxiliary functions. Press the **PATTERN** switch to select the AUX PRINT function.

2. **CATEGORY switch**

Press to initiate a controls printout. *CTRL PRNT* flashes once to acknowledge the request.

3. **RESULTS switch**

Press to initiate a results printout. *RSLT PRNT* flashes once to acknowledge the request.

4. **AUX switch**

Press the **AUX** switch to return to the operating mode (**AUX** switch LED extinguished).

Consider the following auxiliary functions when changing the AUX PRINT function:

- ✦ AUX BUF CLR function
- ✦ AUX BAUD function
- ✦ AUX PARITY function
- ✦ AUX TERM 232 function
- ✦ AUX PRI EVNT function
- ✦ AUX PRI INTV function



AUX BUF CLR — Clear Print Buffer

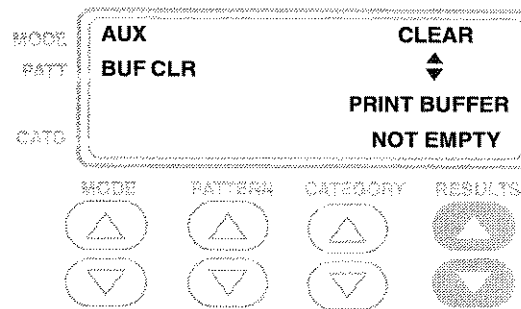

The AUX BUF CLR function terminates any printouts in progress and clears the print buffer. When the AUX BUF CLR function is selected and the print buffer contains stored results, the message *PRINT BUFFER NOT EMPTY* appears in the RESULTS display. When the print buffer is clear, the message *PRINT BUFFER EMPTY* appears in the RESULTS display.

Use the following procedure to clear the print buffer.

1. **AUX and PATTERN switch**

Press the **AUX** switch to activate the auxiliary functions. Press the **PATTERN** switch to select the AUX BUF CLR function.



2. RESULTS switch

Press to clear the print buffer. The message *PRINT BUFFER EMPTY* appears in the RESULTS display when the print buffer is clear.

3. AUX switch

Press the **AUX** switch to return to the operating mode (**AUX** switch LED extinguished).

When using the AUX BUF CLR function consider the printer operation.

AUX PRI EVNT — Print Event

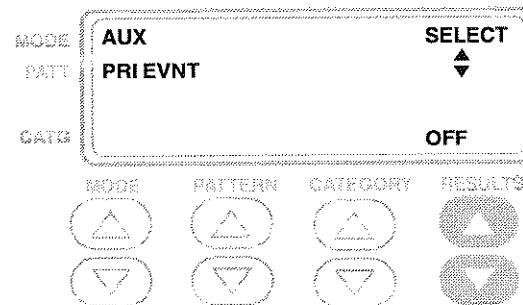

The AUX PRI EVNT function selects what actions will initiate a results printout. Press the **RESULTS** switch to select one of the following:

ERROR — T-BERD 107A generates a results printout once a second when any of the following events occur: bit errors, CRC errors, frame errors, or BPVs.



TIMED—T-BERD 107A automatically generates a results printout after the specified time interval defined by the AUX PRINTV function.

OFF — This setting prevents all automatic results printout generation, but it does not disable manual printout generation via the AUX PRINT function.

Use the following procedure to change the print event setting.

1. **AUX and PATTERN switch**
Press the **AUX** switch to activate the auxiliary functions. Press the **PATTERN** switch to select the AUX PRIEVNT function.
2. **RESULTS switch**
Press to set the print event that initiates results printouts.
3. **AUX switch**
Press the **AUX** switch to return to the operating mode (**AUX** switch LED extinguished).

Consider the following when changing the AUX PRIEVNT function:

- ◆ AUX PRINTV function
- ◆ Printer operation

AUX PRI INTV — Print Interval Time

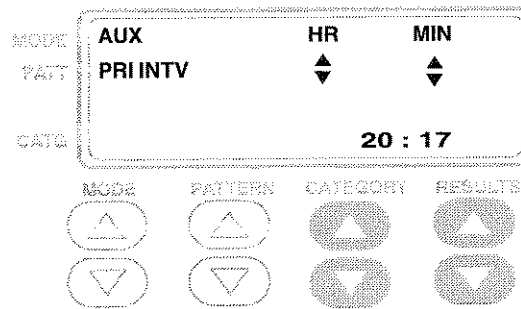

The AUX PRI INTV function sets the print interval time that determines how often a results printout is generated when the AUX PRI EVNT function is set to TIMED. This function operates independent of the AUX TIME TST function. The maximum print interval is 23 hours and 59 minutes, while the minimum print interval is one minute.

Use the following procedure to change the print interval setting.

1. **AUX and PATTERN switch**
Press the **AUX** switch to activate the auxiliary functions. Press the **PATTERN** switch to select the AUX PRI INTV function.
2. **CATEGORY switch**
Press the up arrow (increase) or the down arrow (decrease) to change the print interval hour setting from 0 HRS to 23 HRS.



3. RESULTS switch

Press the up arrow (increase) or the down arrow (decrease) to change the print interval minutes from 0 MIN to 59 MIN.

4. AUX switch

Press the **AUX** switch to return to the operating mode (**AUX** switch LED extinguished).

Consider the following when changing the AUX PRINTV function:

- ◆ AUX PRINTV function
- ◆ Printer operation

AUX PRNTPORT — Printer Interface Setup

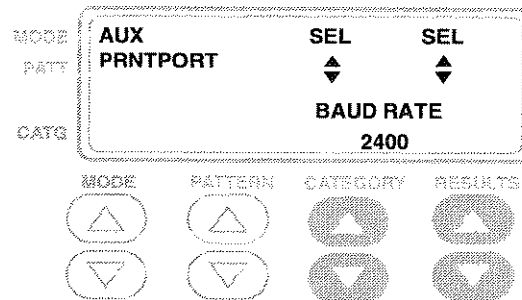

The AUX PRNTPORT function selects the RS-232 printer interface parameters for the PRINTER connector. To select an interface parameter, press the **CATEGORY** switch.



BAUD RATE — Press the **RESULTS** switch to scroll through the baud rate selections of 300, 1200, 2400, 4800, and 9600.

PARITY — Press the **RESULTS** switch to scroll through the parity selections of NONE, ODD, and EVEN. When parity is set to NONE, the data output is automatically set for eight data bits. When parity is set to EVEN or ODD, the data output is set for seven data bits and one parity bit.

TERM 232 — Press the **RESULTS** switch to toggle the RS-232 line termination character between CR (Carriage Return) and CRLF (Carriage Return-Linefeed).

Use the following procedure to set the RS-232 printer interface parameters.

- 1. AUX and PATTERN switch**
Press the **AUX** switch to activate the auxiliary functions. Press the **PATTERN** switch to select the AUX PRNTPORT function.
- 2. CATEGORY switch**
Press either arrow to scroll to the desired parameter, BAUD RATE, PARITY, or TERM232.
- 3. RESULTS switch**
Press either arrow to set the parameter to the desired value.
- 4. Repeat to set other parameters**
Repeat Steps 2 and 3 to set the remaining parameters to the desired values.

3. **AUX switch**

Press the **AUX** switch to return to the operating mode.

Consider the following functions and modes when setting the RS-232 interface parameters:

- PRINTER connector
- Printer operation

Pages 4-33 through 4-35, replace the AUX CLOCK and AUX DATE functions with the following:

AUX CLOCK — Time and Date

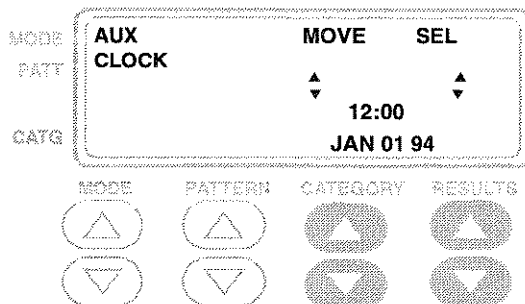

The AUX CLOCK function sets the time (in 24-hour HH:MM format) and date (in MMM DD YY format). The clock time and date appears on all printouts generated by the T-BERD 107A. The time and date are displayed in the TIME category, DATE/TIME result.



Use the following procedure to set the time and date.

1. **AUX and PATTERN switch**

Press the **AUX** switch to activate the auxiliary functions. Press the **PATTERN** switch to select the AUX CLOCK function.

2. **CATEGORY switch**

Press the up arrow to move the highlight from left to right through the five parameters, HH, MM, MMM, DD, and YY. Press the down arrow to move the highlight from right to left.

3. **RESULTS switch**

Press the up arrow (increase) or the down arrow (decrease) to change the highlighted parameter to the desired value, as follows:

HH — 00 to 23 hours.

MM — 00 to 59 minutes.

MMM — three letter abbreviation for month from JAN to DEC.

DD — 01 to 31 days. Internal calendar automatically adjusts the days in each month and for leap year.

YY — 00 to 99.

4. **Repeat to set other parameters**

Repeat Steps 2 and 3 to set the remaining time and date parameters to the desired values.



5. AUX switch

Press the **AUX** switch to return to the operating mode.

Consider the following functions and modes when setting the RS-232 interface parameters:

- SMARTNIU mode Set Clock function
- Printer operation

AUX FT1 IDLE

— Fractional T1 Idle Channel

Code FT1 Option Required

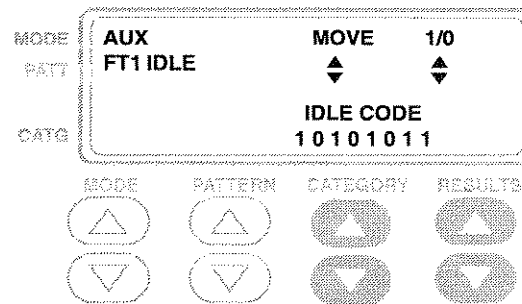

The **AUX FT1 IDLE** function sets the idle channel code to be transmitted on idle channels during FT1 testing. The idle code is always eight bits. One of the bits flashes to indicate that it is in edit mode. To select a different bit to be edited, press the **CATEGORY** switch, which leaves the bit the same, or press the **RESULTS** switch up or down, which changes the bit to a one or zero and automatically advances to the bit on the right.



Use the following procedure to set the idle code.

1. **AUX and PATTERN switch**
Press the **AUX** switch to activate the auxiliary functions. Press the **PATTERN** switch to select the AUXFT1IDLE function.
2. **CATEGORY switch**
Press the up arrow to move from left to right. Press the down arrow to move from right to left. Pressing either arrow after it has reached the end of its range wraps around to the other end.
3. **RESULTS switch**
Pressing the up arrow sets the flashing bit to a one and advances one bit to the right. Pressing the down arrow sets the flashing bit to a zero and moves the cursor one bit to the right.
4. **AUX switch**
Press the **AUX** switch to return to the operating mode.

Consider the following functions and modes when setting the FT1 idle channel code:

- * AUXFT1 CHAN function
- * AUXFT1 RATE function
- * AUXVF TONE function

**AUX FT1 RATE**

— Fractional T1 Channel Rate Select

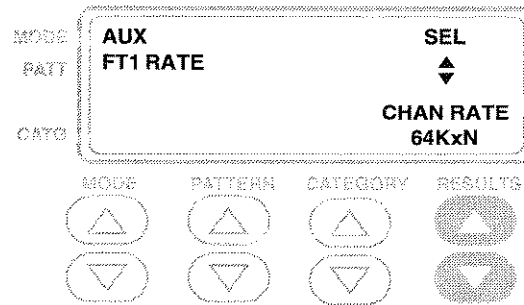
FT1 Option Required

The AUX FT1 RATE function sets the FT1 channel rate for either 56KxN or 64KxN. If the channel rate is set to 56KxN, the bandwidth on the selected FT1 channels is reduced to seven bits, and the Least Significant Bit (LSB) is set to one in the transmitter. This auxiliary function is only active in the FT1 operating modes (FT1 D4, FT1 D1D, and FT1 ESF).

Use the following procedure to set the FT1 channel data rate.

- AUX and PATTERN switch**

Press the **AUX** switch to activate the auxiliary functions. Press the **PATTERN** switch to select the AUX FT1 RATE function.

- RESULTS switch**

Press the **RESULTS** switch up or down arrow to toggle the channel rate between 64KxN and 56KxN.

3. **AUX switch**

Press the **AUX** switch to return to the operating mode.

Consider the following functions and modes when setting the FT1 channel rate:

- AUX FT1 CHAN function
- AUX FT1 IDLE function
- AUX VFTONE function

AUX FT1 CHAN
—Fractional T1 Channel Bandwidth
FT1 Option Required

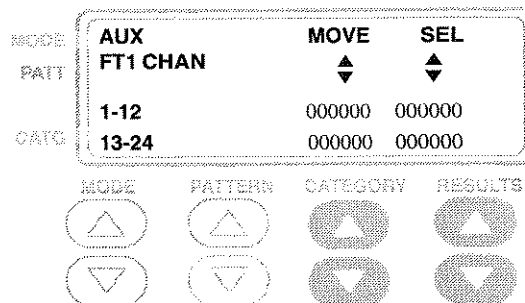

The AUX FT1 CHAN function selects the FT1 channel bandwidth being tested in FT1 circuits. This auxiliary function is only active in the FT1 operating modes (FT1 D4 and FT1 ESF).

Use the following procedure to set the idle code.

1. **AUX and PATTERN switch**

Press the **AUX** switch to activate the auxiliary functions. Press the **PATTERN** switch to select the AUX FT1 CHAN function.

**2. CATEGORY switch**

Pressing the **CATEGORY** switch up arrow moves from left to right and from top row to bottom row. Pressing the **CATEGORY** switch down arrow moves the cursor from right to left and from bottom row to top row. Pressing either arrow after it has reached the end of its range wraps around to the beginning.

3. RESULTS switch

Pressing the up arrow selects the flashing channel and advances the cursor one channel to the right. Pressing the down arrow deselects the flashing channel and moves the cursor one channel to the right.

4. AUX switch

Press the **AUX** switch to return to the operating mode.

Consider the following functions and modes when setting the FT1 channel bandwidth:

- ◆ AUX FT1 IDLE function
- ◆ AUX FT1 RATE function
- ◆ AUX VFTONE function



AUX VF TONE — VF Tone Select

FT1 Option Required

| | | | |
|------|---------|------|-------|
| MODE | AUX | Hz | dBm |
| PATT | VF TONE | ▲▼ | ▲▼ |
| CATG | | 1004 | -13.0 |

| MODE | PATTERN | CATEGORY | RESULTS |
|------|---------|----------|---------|
| ▲ | ▲ | ▲ | ▲ |
| ▼ | ▼ | ▼ | ▼ |

The AUX VFTONE function sets the transmitted VF tone frequency and level for the selected channel.

When in an FT1 mode, if a single channel tone is inserted into the channel selected by the AUX VF CHAN function, an all ones pattern is inserted in the remaining selected FT1 channels (if any), and the FT1 Idle Code is inserted in each of the unselected channels. If the channel selected by the AUX VF CHAN function is not a selected FT1 channel; the VF tone setting is ignored, an all ones pattern is inserted in all the selected FT1 channels, and the FT1 Idle Code is inserted in each of the unselected channels.

NOTE: VF tones are available in non-FT1 modes, but the tone is only inserted in the selected DS0 channel (see AUX VF CHAN function).



Use the following procedure to set the VF tone frequency and level.

1. **AUX and PATTERN switch**
Press the **AUX** switch to activate the auxiliary functions. Press the **PATTERN** switch to select the AUX VF TONE function.
2. **CATEGORY switch**
Press to select the VF tone frequency: 404 Hz, 1004 Hz, 2713 Hz (at 0.0 dBm only), or 2804 Hz.
3. **RESULTS switch**
Press to select the VF tone level: -13.0 dBm, -3.0 dBm, 0.0 dBm, or +3.0 dBm.
4. **AUX switch**
Press the **AUX** switch to return to the operating mode.

Consider the following functions and modes when setting the VF tone frequency and level:

- ◆ AUX FT1 CHAN function
- ◆ AUX FT1 RATE function
- ◆ AUX FT1 IDLE function
- ◆ AUX VF CHAN function

**TEST
RESULTS** **5**

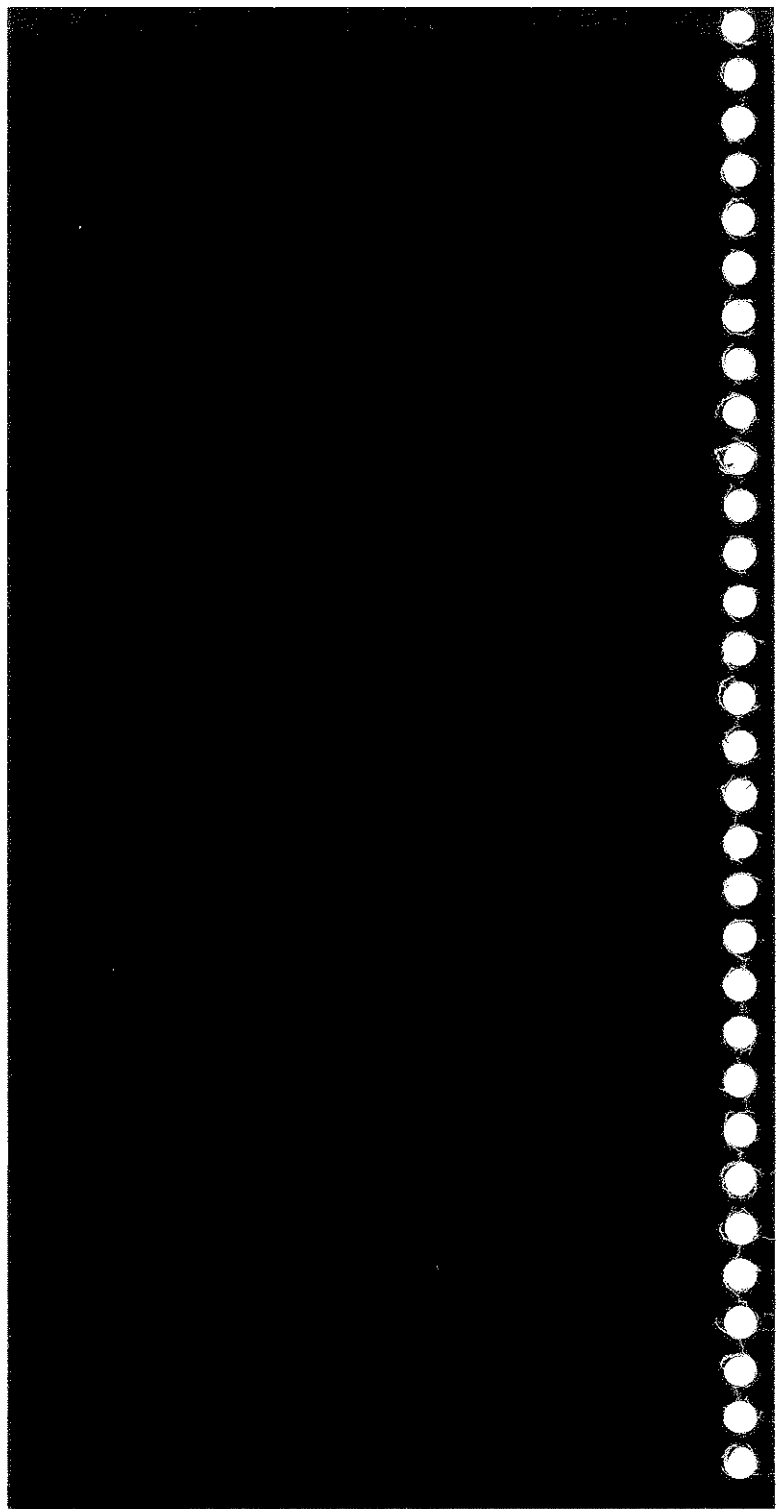



TEST RESULTS

5.1 TEST RESULTS

The T-BERD 107A T-Carrier Analyzer performs a variety of measurements and provides a number of performance results. The measurements and test results are displayed in the RESULTS display.

The test results are divided into five categories. Pressing the **CATEGORY** switch scrolls the category label in the CATEGORY display and displays the previously selected result for that category. The test results in each selected category are displayed by pressing the **RESULTS** switch.

The five test result categories and the available results are listed as follows.

SUMMARY Category

| Mainframe | SLC Datalink Decode Option |
|-------------|-------------------------------|
| | Current Alarm Messages |
| BIT ERRORS | MAJOR ALARM SHELF x |
| VIOLATIONS | MAJOR ALARM NO SHELF |
| FRM ERRORS | ALARM SHELF x |
| CRC ERRORS | FE LOOP SHELF x |
| RX FREQ, Hz | FE LOOP PROTECT |
| TIMING SLIP | SHELF x ON PROT |
| | MINOR ALARM |
| | PWR/MISC ALARM |
| | MAINT HOOK/SEIZE |
| | MAINT PROCEED |
| | MAINT TEST ALARM |
| | DATALINK SYNCLOSS |
| | NO DATALINK SYNC |

**ERRORS Category****Mainframe**

BITERRORS
BIT ERR SEC
BIT ERR RT
CRCERRORS
CRC ERR SEC
CRC ERR RT
FRMERRORS
FRM ERR SEC
FRM ER RATE
VIOLATIONS
BPV SECONDS
BPV RATE

SIGNAL Category**Mainframe**

RXFREQ, Hz
RXLEVEL
SPX CURRENT
TIMING SLIP
TRAFFIC A/B BITS
TRAFFIC C/D BITS (ESF framing only)
DATA BITS
VFRESULTS

TIME Category**Mainframe**

SIG LOS SEC
TESTLENGTH
ELAPSE TIME
TEST END IN
DATE/TIME
BATTERY CHG



DATALINK Category

| SLC Datalink Decode Option | SLC Datalink Decode Option History Alarm Messages |
|-----------------------------------|--|
| SLC ALM SEC | MAJOR ALARM SHELF x |
| ALMFIELD | MAJOR ALARM NO SHELF |
| | ALARM SHELF x |
| | FE LOOP SHELF x |
| | FE LOOP PROTECT |
| | SHELF x ON PROT |
| | MINOR ALARM |
| | PWR/MISC ALARM |
| | MAINT HOOK/SEIZE |
| | MAINT PROCEED |
| | MAINT TEST ALARM |

DATALINK Category

Enhanced ESF Option

PRM TIME
FAR FRM ES
FAR FRM SES
FAR BPV SEC
FAR SLP SEC
FAR PRM SEC
FAR CRC ERR
FCRC 1
FCRC 2-5
FCRC 6-10
FCRC 11-100
FCRC 101-319
FCRC >319
PAY SRC



5.2 SUMMARY CATEGORY

The SUMMARY category displays the following key non-zero or out-of-specification test results without having to scroll through all of the categories to find them.

BIT ERRORS

Bit Errors — A count of received bits which have a value opposite that of the corresponding transmitted bits (one or zero) after pattern synchronization is achieved.

VIOLATIONS

Bipolar Violations (BPVs) — A count of BPVs detected since the start of the test (excluding intentional violations found within B8ZS coding).

FRM ERRORS

Frame Errors — A count of the frame errors detected since the start of the test and after frame synchronization was achieved. For T1 D1D and T1 D4 framing, frame errors are counted if either an F_1 or an F_s frame bit is in error. For T1 SLC framing, frame errors are counted only if an error is found on an F_1 bit.

CRC ERRORS

Cyclic Redundancy Check (CRC) Errors — A count of CRC errors detected. CRC errors are counted only when ESF framing is present in the received T1 data.

**RX FREQ, Hz**

Received Frequency in Hz— The frequency of the clock measured from the received data. The valid range for received frequency is from 1539000 Hz to 1549000 Hz. If the RX FREQ, Hz result exceeds the maximum value >1549000 is displayed. If the RX FREQ, Hz result is less than the minimum value <1539000 is displayed.

TIMING SLIP

Timing Slips— The number of bit slips and framing slips counted when the RX jack input has slipped from the REF jack input. Timing slips are displayed as the number of framing slips and the number of bit slips. Each framing slip equals 193 bit slips. The framing slip total is displayed in the third line of the RESULTS display in a range from -999 to +999. The bit slip total is displayed in the bottom line of the RESULTS display in a range from -192 to +192.

In addition to the test results, the following status messages appear in the SUMMARY category as required.

ALL RESULTS OK— This message is displayed when all summary results are error-free or meet specification boundaries.

ALL RESULTS UNAVAILABLE— This message is displayed when T1 signal presence has not been detected since test restart.

SIGNAL LOSS— This message is displayed when the received signal has been lost. The RESULTS display alternates between the selected test result and *SIGNALLOSS* until the signal returns.

B8ZS DETECTED — This message is displayed when the **B8ZS** switch is set to the AMI position and B8ZS coding is detected in the received signal.

NOT B8ZS COMPATIBLE— This message is displayed when the **B8ZS** switch is set to the B8ZS position, the selected pattern is ALL ZERO, and the instrument receives the sequence 0001 1011. This sequence occurs if a non-B8ZS compatible piece of equipment regenerates the transmitted signal.

FAILED PATTERNS— This message is displayed when the pattern is set to BRIDGTAP or MULTIPAT, and the value of the BIT ERRORS or BIT ERR SEC result for any pattern is greater than zero.

In the ESF operating mode, the following Bit-Patterned Messages (BPMs) appear in the SUMMARY category if BPM RCVR is set to ON in the AUXDATALINK function. Receiving a BPM triggers a time- and date-stamped alarms printout.

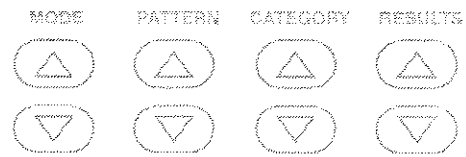
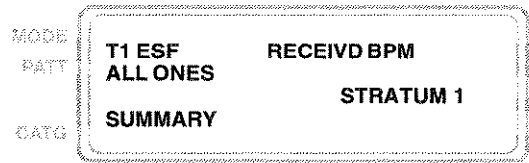

**NOT FOR SYNC**

Not For Synchronization— A received BPM stating timing source is not suitable for synchronization.

SONET

SONET Clock Traceable— A received BPM stating timing is recognized as a SONET clock.

STRATUM 1

Stratum 1 Clock Traceable — A received BPM stating timing is recognized as a Stratum 1 clock.

STRATUM 2

Stratum 2 Clock Traceable — A received BPM stating timing is recognized as a Stratum 2 clock.

STRATUM 3

Stratum 3 Clock Traceable — A received BPM stating timing is recognized as a Stratum 3 clock.

STRATUM 4

Stratum 4 Clock Traceable — A received BPM stating timing is recognized as a Stratum 4 clock.

SYNC UNKNOWN

Synchronization Quality Unknown— A received BPM stating the synchronization timing is either unknown or the signal is asynchronous.

USER

User BPM Detected— A received BPM stating the signal is recognized as an eight-bit user-programmable BPM.

The following SUMMARY category alarm and maintenance messages act as a current indication of the messages that are received from the SLC-96 datalink. The SLC Datalink Decode Option is required for these messages.

MAJOR ALARM SHELF x

Major Alarm on Shelf x— This message is displayed when a major alarm is detected with an accompanying alarm on the indicated shelf (x = A, B, C, or D).

MAJOR ALARM NO SHELF

Major Alarm, No Shelf— This message is displayed when a major alarm is detected without an accompanying shelf alarm.

ALARM SHELF x

Shelf Alarm on Shelf x— This message is displayed when a shelf alarm condition exists on the indicated shelf (x = A, B, C, or D) without an accompanying major alarm.

FE LOOP SHELF x

Far-End Loop on Shelf x— This message is displayed when a request is sent to the far end to loop the indicated shelf (x = A, B, C, or D).

FE LOOP PROTECT

Far-End Loop on Protection Line— This message is displayed when a request is sent to the far end to loop the protection shelf.

**SHELF x ON PROT**

Shelf x on Protection Line— This message is displayed when the indicated shelf (x = A, B, C, or D) has been switched to the protection shelf. Three consecutive datalink frames must indicate that a shelf has been switched to the protection shelf before this alarm message is displayed.

MINOR ALARM

Minor Alarm — This message is displayed when a minor alarm condition exists.

PWR/MISC ALARM

Power/Miscellaneous Alarm— This message is displayed when a power/miscellaneous alarm condition exists on a specific shelf.

MAINT HOOK/SEIZE

On-Hook/Seize Maintenance Message— This message is displayed when the *ON-HOOK* or *SEIZE RC* message is detected in the maintenance field. It indicates that either the line is being released at the end of the test or seized at the beginning of the test.

MAINT PROCEED

Proceed Maintenance Message — This message is displayed when the *PROCEED CR* or *PROCEED RC* message is detected in the maintenance field. It indicates that the system is ready to proceed with the test.

MAINT TEST ALARM

Test Alarm Maintenance Message — This message is displayed when the *TESTALMCR* or *TESTALMRC* message is detected in the maintenance field. It indicates an error has been detected in the maintenance test and the test should be aborted.

DATALINK SYNC LOSS

Datalink Synchronization Loss — This message is displayed when SLC datalink synchronization has been lost. If a category other than SUMMARY is selected when the datalink synchronization is lost, the display alternates between the selected test result and *DATALINK SYNC LOSS* message until datalink synchronization returns.

NO DATALINK SYNC

No Datalink Synchronization — This message is displayed when the T-BERD 107A has failed to obtain SLC datalink synchronization.

The following SUMMARY category PRM test results are received from the ESF datalink. The Enhanced ESF Option is required for these test results. If a “~” (tilde symbol) precedes a far end test result, it indicates the results are an approximate value due to lost PRMs.

FAR FRM ES

Far-End Frame Error Seconds — A count of the seconds in which one or more frame errors occurred in the received signal at the far end. This result reports on the PRM Frame-Synchronization-Bit Error Event Bit (FE = 1) status.

**FAR FRM SES**

Far-End Severely Errored Framing Seconds— A count of the seconds in which two or more frame errors occurred in less than 3 ms in the received signal at the far end. This result reports on the PRM Severely-Errored Framing Event Bit (SE = 1) status.

FAR BPV SEC

Far-End BPV Seconds — A count of the seconds in which one or more BPVs occurred in the received signal at the far end. This result reports on the PRM Line-Code Violation Event Bit (LV = 1) status.

FAR SLP SEC

Far-End Controlled Slip Seconds— A count of the seconds in which controlled slips occurred in the received signal at the far end. This result reports on the PRM Controlled-Slip Event Bit (SL = 1) status.

FAR CRC ERR

Far-End CRC Error Events— A count of the minimum number of CRC errors reported in the FCRC results. A “>” (greater than) preceding the count indicates Bins 2 through 6 are non-zero (see DATALINK Category). This result reports on the PRM CRC Error Event Bits (G1 to G6) status.

5.3 ERRORS CATEGORY

BIT ERRORS

Bit Errors — A count of received bits which have a value opposite that of the corresponding transmitted bits (one or zero) after pattern synchronization is achieved.

BIT ERR SEC

Bit Errored Seconds — A count of test seconds where one or more bit errors occurred.

BIT ERR RT

Bit Error Rate — The ratio of detected bit errors to the number of data bits after pattern synchronization is achieved.

CRC ERRORS

Cyclic Redundancy Check (CRC) Errors — A count of CRC errors detected. CRC errors are counted only when ESF framing is present in the received T1 data.

CRC ERR SEC

CRC Errored Seconds — A count of seconds within which one or more CRC errors are detected.

CRC ERR RT

CRC Error Rate — A count of CRC errors divided by the total number of ESF superframes analyzed.

**FRM ERRORS**

Frame Errors — A count of the frame errors detected since the start of the test and after frame synchronization was achieved. For T1 D1D and T1 D4 framing, frame errors are counted if either an F_1 or an F_s frame bit is in error. For T1 SLC framing (SLC-M1 or SLC-M2 framing if SLC Datalink Decode Option is installed), frame errors are counted only if an error is found on an F_1 bit. Frame errors are not monitored or counted when T1 ESF framing is selected.

FRM ERR SEC

Frame Errored Seconds — A count of the seconds during which one or more frame errors occurred.

FRM ER RATE

Frame Error Rate — The ratio of frame errors to the number of analyzed framing bits.

VIOLATIONS

Bipolar Violations (BPVs) — A count of BPVs detected since the start of the test (excluding intentional violations found within B8ZS coding).

BPV SECONDS

BPV Seconds — A count of the seconds within which one or more BPVs occurred.

BPV RATE

BPV Rate — The ratio of BPVs to the number of data bits received.



Table 5-1
Signal Level Test Locations

| Location | Typical Signal Level | Description |
|---|-----------------------------------|---|
| Mid-span repeater Input (SIDE1/SIDE1 IN) Output (SIDE1/SIDE2 OUT) | -25 dBdsx to -30 dBdsx 0 dBdsx | Input signal range for regeneration. Output signal level after regeneration. |
| DSX-1 monitor jack | -20 dBdsx | Signal level expected after 430 ohm isolation resistors. |
| Distribution frame | -15 dBdsx | Signal level needed when circuit is looped for regeneration at first repeater. |
| NIU | -15 dBdsx | Signal energy needed when circuit is looped for regeneration at last repeater. |
| CSU | -15 dBdsx | Signal energy needed when circuit is looped for regeneration at last repeater. |



5.4 SIGNAL CATEGORY

RX FREQ, Hz

Received Frequency in Hertz (Hz) — The frequency of the clock measured from the received data. The valid range for received frequency is from 1539000 Hz to 1549000 Hz. If the RXFREQ, HZ is greater than the valid range of values, the message *>1549000* is displayed. If the RXFREQ, HZ is less than the valid range of values, the message *<1539000* is displayed.

RX LEVEL

Received Signal Level in dBdsx and in Volts Peak-to-Peak — The level of the received signal in dB relative to a standard six-volt peak-to-peak signal (dBdsx) is displayed in the third line of the RESULTS display. The level of the received signal in peak-to-peak volts is displayed in the bottom line of the RESULTS display. The signal level is displayed as Vp-p or mVp-p when it is higher or lower than one volt, respectively.

Table 5-1 provides the typical signal levels for various locations within the T1 network. If the RX LEVEL is greater than the valid range of values (see Section 7 Specifications), the message *TOO HIGH* is displayed in place of the dBdsx value and *>12.0 Vp-p* is displayed. If the RXLEVEL is less than the valid range of values, the message *TOO LOW* is displayed in place of the dBdsx value and *<60 mVp-p* is displayed.

SPX CURRENT

Simplex Current—The magnitude of the simplex current flowing between the transmit output tip and ring and the receive input tip and ring. Simplex current is displayed as a number from 10 to 200 followed by the label mA for milliamperes. If the current is less than 10 mA, the value <10 mA is displayed. If the current exceeds 200 mA, the value >200 mA is displayed.

TIMING SLIP

Timing Slips—The number of bit slips and framing slips counted when the RX jack input has slipped from the REF jack input. Timing slips are displayed as the number of framing slips and the number of bit slips. Each framing slip equals 193 bit slips. The framing slip total is displayed in the third line of the RESULTS display in a range from -999 to +999. The bit slip total is displayed in the bottom line of the RESULTS display in a range from -192 to +192.

TRAFFIC A/B BITS

Traffic A/B Bits—The RESULTS display shows the A and B signaling bits for all 24 DS0 channels (as shown).

| | | | |
|------|-------|---------------------|---------------|
| MODE | T1 D4 | TRAFFIC A/B BITS | |
| PATT | | a | 101010 101010 |
| | 01-12 | b | 000000 000000 |
| CATG | | a | 101010 101010 |
| | 13-24 | b | 000000 000000 |

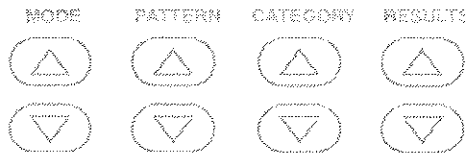



TRAFFIC C/D BITS

Traffic C/D Bits — The RESULTS display shows the C and D signaling bits for all 24 DS0 channels (see below). This result is only available with ESF framing.

| MODE | T1 ESF | TRAFFIC C/D BITS |
|------|--------|------------------------------------|
| PATT | 01-12 | c 101010 101010 d 101010 101010 |
| CATG | 13-24 | c 101010 101010 d 101010 101010 |

| MODE | PATTERN | CATEGORY | RESULTS |
|------|---------|----------|---------|
| | | | |
| | | | |

DATA BITS

Data Bits — The RESULTS display shows the 8-bit byte of the channel selected via the AUX CH DROP function. The DATA BITS result updates upon receipt of each byte. The DATA BITS are displayed as shown below, where ZZ is the number of the selected drop channel. If the dropped channel is set to NONE, the ZZ is replaced by two dashes (—) and the DATA BITS result displays *NO CHANNEL*. Pressing the **PATTERN** switch changes the selected channel that is displayed and that is dropped to the speaker and VF OUT jack.



| | | |
|------|--------|-----------|
| MODE | T1 D4 | DATA BITS |
| PATT | CH ZZ | |
| CATG | SIGNAL | 10101010 |

| MODE | PATTERN | CATEGORY | RESULTS |
|------|---------|----------|---------|
| | | | |
| | | | |

VF RESULTS

VF RESULTS—The RESULTS display shows the VF signal level (in dBm) and frequency (in Hz) for the selected channel. The VF RESULTS are displayed as shown, where ZZ is the number of the selected drop channel, +/-##.# dBm is the signal level with a range from +3.0 to -40.0 dBm, and #### Hz is the frequency with a range from 60 to 3904 Hz. If the dropped channel is set to NONE, the ZZ is replaced by two dashes (—) and the VF RESULTS are both displayed as *NO CHANNEL*. Pressing the **PATTERN** switch changes the selected channel that is displayed and that is dropped to the speaker and VF OUT jack.

| | | |
|------|--------|------------------------|
| MODE | T1 D4 | VF RESULTS |
| PATT | CH ZZ | |
| CATG | SIGNAL | +/-##.# dBm #### Hz |

| MODE | PATTERN | CATEGORY | RESULTS |
|------|---------|----------|---------|
| | | | |
| | | | |



5.5 TIME CATEGORY

SIG LOS SEC

Signal Loss Seconds — A count of test seconds since the signal has been lost or during which one or more signal losses occurred.

TEST LENGTH

Length of a Timed Test — The current test length for a timed test, in HHH:MM format. If the AUX TIME TST function is set to CONTINUOUS, the message *CONTINUOUS* is displayed.

ELAPSE TIME

Elapsed Time — The number of hours, minutes, and seconds in HHH:MM:SS format since a valid frequency and level has been detected.

TEST END IN

Time Remaining in Timed Test — Time remaining in a timed test, in HHH:MM:SS format. If the AUX TIME TST function is set to CONTINUOUS, four asterisks (****) are displayed.

DATE/TIME

Date/Clock Time of Day — The date in MMM DD format is displayed in the third line of the RESULTS display. The time of day in HH:MM:SS format is displayed in the bottom line of the RESULTS display.

BATTERY CHG

Battery Charge Level — Relative level of battery power remaining. This value is displayed using five boxes. The far left is marked by an *E* for empty, and the far right is marked by an *F* for fully charged. The level of battery power is the number of filled boxes from left to right.

5.6 DATALINK CATEGORY

The following DATALINK category results are decoded from the SLC datalink messages. The SLC Datalink Decode Option must be installed to provide the following test results.

In the ESF operating mode, the following Bit-Patterned Messages (BPMs) appear in the DATALINK category if BPMRCVR is set to ON in the AUXDATALINK function. These messages are stored until the next test restart. Receiving a BPM triggers a time- and date-stamped alarms printout.

NOT FOR SYNC

Not For Synchronization — A received BPM stating timing source is not suitable for synchronization.

SONET

SONET Clock Traceable — A received BPM stating timing is recognized as a SONET clock.

STRATUM 1

Stratum 1 Clock Traceable — A received BPM stating timing is recognized as a Stratum 1 clock.

**STRATUM 2**

Stratum 2 Clock Traceable — A received BPM stating timing is recognized as a Stratum 2 clock.

STRATUM 3

Stratum 3 Clock Traceable — A received BPM stating timing is recognized as a Stratum 3 clock.

STRATUM 4

Stratum 4 Clock Traceable — A received BPM stating timing is recognized as a Stratum 4 clock.

SYNC UNKNOWN

Synchronization Quality Unknown — A received BPM stating the synchronization timing is either unknown or the signal is asynchronous.

USER

User BPM Detected — A received BPM stating timing is recognized as an eight-bit user-programmable BPM.

SLC ALM SEC

SLC Alarm Seconds — This is a count of the seconds during which one or more SLC-96 Datalink Alarms occurred. SLC ALM SEC is displayed as a number from 0 to 99999999, and it is updated once per test second. If the value exceeds the displayed maximum, a greater than sign (>) is inserted on the left and the displayed digits remain accurate.

**ALM FIELD**

SLC Alarm Field Size— This is the detected size of the SLC alarm field. ALM FIELD is displayed as shown below, where XX is the number of bits in the alarm field (XX = 13 or 16).

The following DATALINK category alarm and maintenance messages are displayed as a historical record when they are no longer displayed in the SUMMARY category as current messages. The SLC Datalink Decode Option must be installed to provide the following alarm and maintenance messages.

MAJOR ALARM SHELF x

Major Alarm on Shelf x — This message is displayed when a major alarm is detected with an accompanying alarm on the indicated shelf (x = A, B, C, or D).

MAJOR ALARM NO SHELF

Major Alarm, No Shelf — This message is displayed when a major alarm is detected without an accompanying shelf alarm.

ALARM SHELF x

Shelf Alarm on Shelf x — This message is displayed when a shelf alarm condition exists on the indicated shelf (x = A, B, C, or D) without an accompanying major alarm.

FE LOOP SHELF x

Far-End Loop on Shelf x — This message is displayed when a request is sent to the far end to loop the indicated shelf (x = A, B, C, or D).

FE LOOP PROTECT

Far-End Loop on Protection Line — This message is displayed when a request is sent to the far end to loop the protection shelf.

**SHELF x ON PROT**

Shelf x on Protection Line— This message is displayed when the indicated shelf (x = A, B, C, or D) has been switched to the protection shelf. Three consecutive datalink frames must indicate that a shelf has been switched to the protection shelf before this alarm message is displayed.

MINOR ALARM

Minor Alarm — This message is displayed when a minor alarm condition exists.

PWR/MISC ALARM

Power/Miscellaneous Alarm— This message is displayed when a power/miscellaneous alarm condition exists on a specific shelf.

MAINT HOOK/SEIZE

On-Hook/Seize Maintenance Message— This message is displayed when the *ON-HOOK* or *SEIZE RC* message is detected in the maintenance field. It indicates that either the line is being released at the end of the test or seized at the beginning of the test.

MAINT PROCEED

Proceed Maintenance Message — This message is displayed when the *PROCEED CR* or *PROCEED RC* message is detected in the maintenance field. It indicates that the system is ready to proceed with the test.

MAINT TEST ALARM

Test Alarm Maintenance Message— This message is displayed when the *TESTALM CR* or *TESTALM RC* message is detected in the maintenance field. It indicates an error has been detected in the maintenance test and the test should be aborted.

**FAR BPV SEC**

Far-End BPV Seconds — A count of the seconds in which one or more BPVs occurred in the received signal at the far end. This result reports on the PRMLine-Code Violation Event Bit (LV = 1) status.

FAR SLP SEC

Far-End Controlled Slip Seconds— A count of the seconds in which controlled slips occurred in the received signal at the far end. This result reports on the PRM Controlled-Slip Event Bit (SL = 1) status.

FAR CRC ERR

Far-End CRC Error Events— A count of the minimum number of CRC errors reported in the FCRC results. A “>” (greater than) preceding the count indicates Bins 2 through 6 are non-zero. This result reports on the PRM CRC Error Event Bits (G1 to G6) status.

FCRC 1

Far-End CRC 1 Bin— A count of the seconds with only one CRC error reported in the received signal at the far end. This result reports on the first PRM CRC Error Event Bit (G1 = 1) status.

FCRC 2-5

Far-End CRC 2 to 5 Bin — A count of the seconds with two to five CRC errors reported in the received signal at the far end. This result reports on the second PRM CRC Error Event Bit (G2 = 1) status.

FCRC 6-10

Far-End CRC 6 to 10 Bin — A count of the seconds with six to ten CRC errors reported in the received signal at the far end. This result reports on the third PRM CRC Error Event Bit (G3 = 1) status.

FCRC 11-100

Far-End CRC 11 to 100 Bin — A count of the seconds with 10 to 100 CRC errors reported in the received signal at the far end. This result reports on the fourth PRM CRC Error Event Bit (G4 = 1) status.

FCRC 101-319

Far-End CRC 101 to 319 Bin — A count of the seconds with 101 to 319 CRC errors reported in the received signal at the far end. This result reports on the fifth PRM CRC Error Event Bit (G5 = 1) status.

FCRC >319

Far-End CRC 320 to 333 Bin — A count of the seconds with 320 to 333 CRC errors reported in the received signal at the far end. This result reports on the sixth PRM CRC Error Event Bit (G6 = 1) status.

**PAY SRC**

Far-End Payload Source/Loopback—Identifies the direction of the PRM according to the PRM Command/Response Bit (C/R) and the PayloadLoopback Activated Bit (LB). In end-to-end applications, a customer generated PRM is indicated as CUST (C/R=0 and LB=0) and a carrier generated PRM is indicated as CARR (C/R = 1 and LB = 0). In payload loopback applications, the customer generated PRM is indicated as CUST LOOP (C/R = 0 and LB=1) when the customer is looped back and the carrier generated PRM is indicated as CARR LOOP (C/R = 1 and LB = 1) when the carrier is looped back.

**SECTION
PRINTER
OPERATION**

6

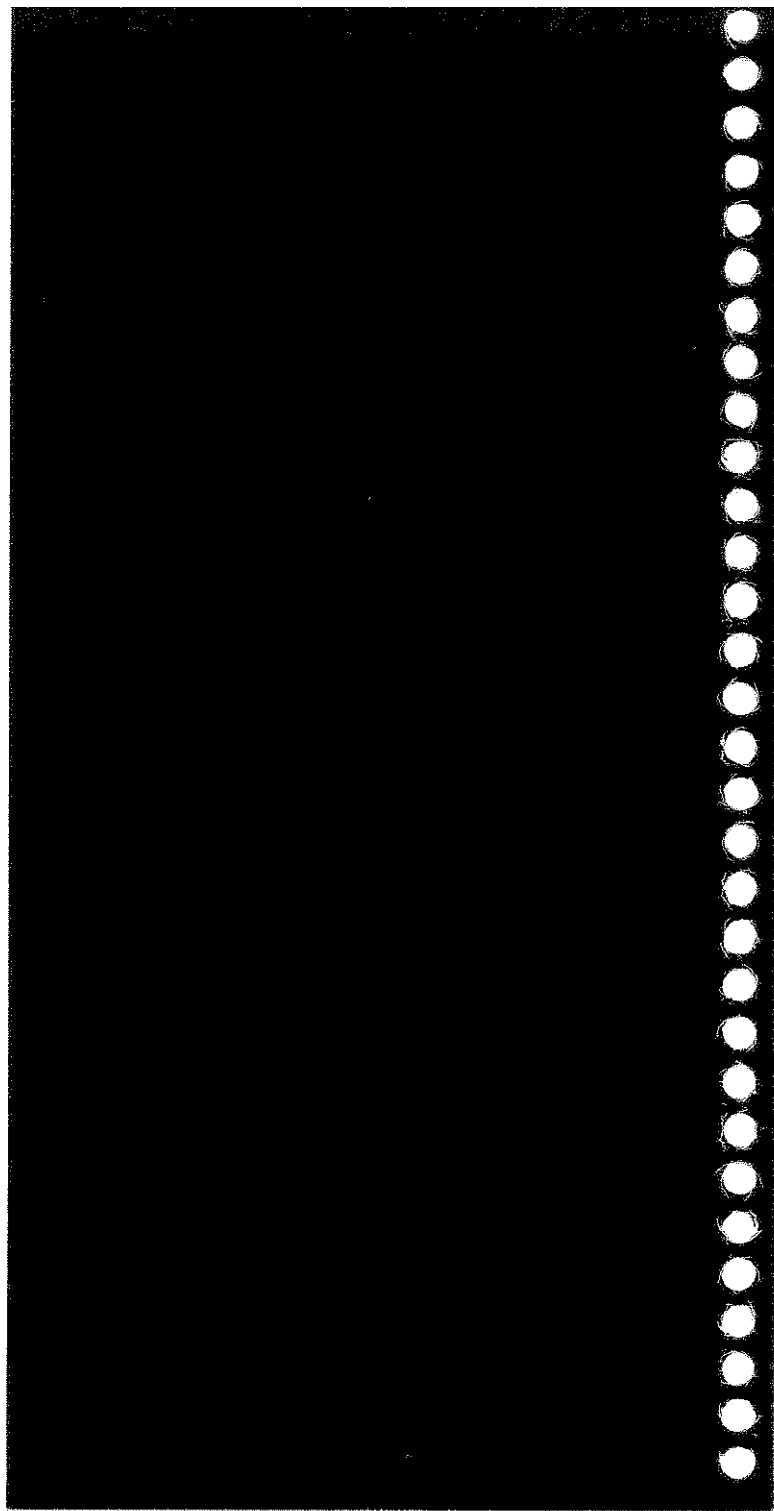



PRINTER OPERATION

6.1 COMPATIBLE PRINTERS

This T-BERD 107A can generate printouts to an RS-232 serial printer such as the TTC PR-40A Thermal Printer. The T-BERD 107A RS-232 interface is configured to operate with the PR-40A Thermal Printer without having to change any of the settings on either device.

6.2 PRINTER OPERATION

The PRINTER connector on the top panel enables the T-BERD 107A to generate hard-copy printouts of test results, alarm messages, and front-panel setups. The PRINTER connector is a circular, 8-pin, DIN-type connector configured to function as Data Communications Equipment (DCE), which allows it to be directly connected to Data Terminal Equipment (DTE). Connection to other DCE is possible with the use of a null modem cable.

If a printer is not attached to the PRINTER connector, the T-BERD 107A stores the printouts in nonvolatile memory (NOVRAM) until a printer is available.



Auxiliary functions are used to select the interface parameters of baud rate, parity, and line terminator. Column length is preset to 80 characters. Table 6-1 shows the auxiliary functions used to configure the interface parameters. The default settings match the PR-40A Thermal Printer parameters, so no changes are needed to operate with the PR-40A Thermal Printer.

Perform the following procedure to set the T-BERD 107A printer interface parameters in the auxiliary function.

1. **Apply power to the T-BERD 107A**
Press the **POWER** switch on the lid panel. Observe that instrument start up and self test are satisfactory.
2. **AUX switch**
Press the switch to illuminate the LED.
3. **PATTERN switch**
Press to select the AUX PRNTPORT function.
4. **Set the baud rate**
Press the **CATEGORY** switch to select BAUD RATE and press the **RESULTS** switch to select either 300, 1200, 2400, 4800, or 9600.
5. **Set the Parity**
Press the **CATEGORY** switch to select PARITY and press the **RESULTS** switch to select either EVEN PARITY, ODD PARITY, or NO PARITY.

Table G-1
Printer Interface Parameters

| AUX PRINTOIRT Parameters Default | Definition | Selections |
|-------------------------------------|------------------|---------------------------------------|
| BAUDRATE 2400 | Baud Rate Select | 300, 1200, 2400, 4800, or 9600 |
| PARITY NOPARITY | Parity Select* | EVENPARITY, ODDPARITY, or NOPARITY |
| TERMINATOR CR | Line Terminator | CR or CRLF |

* Word length is controlled by the parity selection, seven bits for odd or even parity and eight bits for no parity.





6. **Set the RS-232 terminator**
Press the **CATEGORY** switch to select TERM 232 and press the **RESULTS** switch to select either CR or CRLF.
7. **AUX switch**
Press the switch to extinguish the LED. The character display should return to the previous operating mode.

6.3 CONNECTING THE PRINTER

Perform the following procedure to connect the TTC PR-40A Thermal Printer to the T-BERD 107A.

1. **Printer interface parameters verification**
Before connecting the printer to the T-BERD 107A verify that the PRINTER connector interface parameters (see Table 6-1) match the interface parameters of the printer. The T-BERD 107A default parameters match the PR-40A default parameters. Once the interface parameters are verified, turn the power off on both instruments.
2. **Printer connection to the T-BERD 107A**
Connect the printer to the T-BERD 107A PRINTER connector using a circular 8-pin DIN-type to 25-pin D-type connector cable (Model #30758).



3. Apply power to the T-BERD 107A and printer

Turn the T-BERD 107A on first, then the PR-40A. If this step is reversed, the first printout can be garbled.

NOTE: When connecting a compatible printer other than the PR-40A to the T-BERD 107A, connect the printer to the T-BERD 107A, turn the printer power on first, and place the printer OFF LINE before turning the T-BERD 107A ON.

4. Place the printer ON LINE

The PR-40A must be placed ON LINE manually (see the *PR-40A Thermal Printer Operating Manual*).

NOTE: When the printer is placed ON LINE the T-BERD 107A immediately sends any printouts stored in memory.

6.4 GENERATING A PRINTOUT

Printout generation is controlled by the AUX PRINT function, AUX PRIEVNT function, and the AUX PRIINTV function. For more information on these auxiliary functions, refer to Section 4 Auxiliary Functions.



AUX PRINT function — The AUX PRINT function is used to manually generate either results or controls printouts. The two selections and their functions are:

RSLT PRNT — Make this selection to generate a printout of current test results. Results printouts are fully described in Section 6.5.1 Results Printout.

CTRL PRNT — Make this selection to generate a printout of the T-BERD 107A current switch settings and auxiliary functions. Controls printouts are fully described in Section 6.5.2 Controls Printout.

AUX PRI EVNT — The AUX PRI EVNT function has three selections that determine when a results printout is generated. The three AUX PRI EVNT selections and their functions are:

OFF — Prevents data from being sent to the RS-232 printer interface. Note that results and controls printouts are still available using the AUX PRINT function.

TIMED — Initiates a results printout at the end of each time interval as set by the AUX PRI INTV function.

ERROR — Initiates a results printout for each second that a logical bit error, CRC error, frame error, or bipolar violation occurs.

AUX PRI INTV — The AUX PRI INTV function operates in conjunction with the AUX PRI EVNT function's **TIMED** position to set the time interval for periodic generation of a results printout.



6.5 TYPES OF PRINTOUTS

The T-BERD 107A generates three types of printouts: controls, results, and messages. Each printout is identified by a header and is time- and date-stamped.

If the operator attempts to store a printout when the print buffer is full, the printout does not overwrite a previous printout, and the data is not stored. The print buffer can be cleared by selecting the AUX BUF CLR function and pressing the **RESULTS** switch or by connecting the instrument to a compatible serial printer like the PR-40A Thermal Printer.

All printouts are in 80-column format. The format will wraparound when printed to a 40-column printer, such that the information will align in two columns instead of four. The following paragraphs describe each of the available printouts and how to generate them.

6.5.1 Results Printouts

The T-BERD 107A generates four types of results printouts standard, BRIDGTAP, MULTIPAT, and results overflow. To prevent an overflow of the print buffers by a severe error situation that lasts more than a minute, a printer squelch function interrupts the sequence of results printouts and substitutes a summary printout for the squelched time period.



Standard Results Printouts

The standard results printout is a hard-copy listing of the current test results. The format includes all available results and any Alarm LEDs that are illuminated at the time the printout is initiated. Figure 6-1 is an example of a standard results printout. A results printout is initiated manually using the AUXPRINT function or automatically using the AUXPRIEVNT function.

```
RESULTS PRINT      12:56:16      JAN 05
T1 ESF             1:7
BIT ERR    119405  BIT E SEC      29
BER        1.71 E-03  SLIPS      UNAVAIL
BPV ERR          0  BPV ER SEC      0
BPV RATE  0 E-07  FRA ER SEC     N/A
FRA ERR          N/A  F E RATE     N/A
CRC ERR        2591  CRC ER SEC      29
CRC E RT1.59E-01  FREQ Hz    1543990
RX LVL+5.5 dBdsx  RX LVL  11.27 Vp-p
SPX CUR  UNAVAIL  SIG LS SC      0
TEST LEN  CONT  ELAPS TIM 00:00:45
TEST END  ****

CHANNEL RESULTS
CH. DROPPED    16
VF FREQ Hz    1004  VF LVL      -15 dBm
DATA BITS01000000  SIG BITS      0101

SIGNALING BITS (ALL CHANNELS)
A: 000000 111111 000000 111111
B: 111111 000000 111111 000000
C: 000000 111111 000000 111111
D: 111111 000000 111111 000000

ALARM/STATUS
EX ZERO HIST  ON  T1 PULSES      ON
PATTERN SYNC  ON  FRAME SYNC     ON
```

Figure 6-1
Results Printout



BRIDGTAP Test Results Printouts

The BRIDGTAP results printout includes the bit errors (BIT ERR), errored seconds (ERR SEC), and pattern synchronization seconds (SYNC SEC) for each of the 21 patterns in the BRIGDTAP test pattern (see Figure 6-2).

When bit errors are not detected, BITERR and ERR SEC remain at zero and SYNC SEC indicates the number of seconds the synchronized pattern was received and monitored for errors. Each synchronized pattern is monitored for only 23 seconds during each cycle of the BRIDGTAP test.

In Figure 6-2, the results printout shows that the ALL ONES through 2:10 patterns were monitored a second time (46 seconds), a second 2:11 pattern was interrupted when the printout was generated (24 seconds), and the 2:12 through QRSS patterns were monitored once during the BRIDGTAP test. The BITERR result equals the sum of the 21 BRIDGTAP test pattern bit errors. The ASYNE SEC result equals the sum of the BRIDGTAPERR SEC results. When pattern synchronization is lost, SYNC SECs are not counted.



```

RESULTS PRINT      18:04:50   JAN 01
T1 D4   BRIDGTAP
BIT ERR   225423   ASYN E SEC      74
BER      **3.91E-06   SLIPS          9
BPV ERR   2411   BPV ER SEC      *7
BPV RATE  17E-05   FRA ER SEC      5
FRA ERR    22   F E RATE     12E-05
CRC ERR    99   CRC ER SEC      7
CRC E RT   2E-04   FREQ Hz     1544010
RX LVL -19 dBdsx   RX LVL    2.33 Vb-p
SPX CUR   57 mA   SIG LOS SEC      5
TEST LEN  CONTI   ELAPS TIM 00:22:14
TEST END  *****

CHANNEL RESULTS
CH. DROPPED  16
VF FREQ Hz  1004   VF LVL     -15 dBm
DATA BITS01000000 SIG BITS      01

SIGNALING BITS (ALL CHANNELS)
A: 000000 111111 000000 111111
B: 111111 000000 111111 000000

BRIDGTAP RESULTS
PATTERN  BIT ERR  ERR SEC  SYNC SEC
ALL ONES      0    0          46
1:1           0    0          46
1:3           0    0          46
1:5           0    0          46
1:6          16123  6          46
1:7          16124  5          46
.
.
.
3 IN 24      0    0          23
QRSS         0    0          23

ALARM STATUS
SIG LOS      ON  PATTERN LOSS  ON
FRAME LOSS   ON

```

Figure 6-2
Simulated BRIDGTAP Results Printout



MULTIPAT Test Results Printouts

The MULTIPAT results printout includes the bit errors (BIT ERR), errored seconds (ERR SEC), and pattern synchronization seconds (SYNC SEC) for each of the five patterns in the MULTIPAT test pattern (see Figure 6-3).

```

RESULTS PRINT      18:04:50   JAN 01
T1 D4  MULTIPAT
BIT ERR      1340  ASYN E SEC      802
BER      **3.91E-06  SLIPS          9
      .
      .
      .
SPX CUR      57 mA  SIG LS SC          5
TEST LEN  CONTI  ELAPS TIM 00:22:14
TEST END      *****

CHANNEL RESULTS
CH. DROPPED  16
VF FREQ Hz  1004  VF LVL      -15 dBm
DATA BITS01000000  SIG BITS      01

SIGNALING BITS (ALL CHANNELS)
A: 000000 111111 000000 111111
B: 111111 000000 111111 000000

MULTIPAT RESULTS
PATTERN  BIT ERR  ERR SEC  SYNC SEC
ALL ONES      260  168          175
1:7           271  175          175
2 IN 8        270  167          175
3 IN 24       269  158          175
QRSS          270  134          175

ALARM STATUS
SIGNAL LOSS  ON  PATTERN LOSS  ON
FRAME LOSS   ON

```

Figure 6-3
Simulated Multipattern Results Printout



When bit errors are not detected, BITERR and ERR SEC results remain at zero and SYNC SEC indicates the number of seconds the synchronized pattern was received and monitored for errors. Each synchronized pattern is monitored for 175 seconds during each cycle of the MULTIPAT test.

The BITERR result equals the sum of the five MULTIPAT test pattern bit errors. The ASYN E SEC result equals the sum of the five MULTIPAT test pattern errored seconds. If pattern synchronization is lost, SYNC SEC results are not counted.

SMART NIU Results Printout (Enhanced ESF Option only)

The Smart NIU results printout lists the statistics retrieved from the NIU/Performance Monitor at the end of a standard results printout. A complete SMART NIU results printout includes up to eight days of T1 circuit performance statistics as retrieved from the NIU/Performance Monitor. These results include statistics for the current hour (CURRENT HOUR), each of the previous 23 hours (HISTORY HOUR 01 through HISTORY HOUR 23), the current day (CURRENT DAY), and the previous week (HISTORY DAY 01 through HISTORY DAY 07) as shown in Figure 6-4.



SMART NIU RESULTS DATA COLLECTED AT:

13:14 08-27-93

Key for STAT res.

1 = Looped Back
2 = Data Incomplet
3 = Loss of Signal
4 = Unused
5 = Power Loss
6 = AIS
7 = Yellow Alarm
8 = Out of Frame

AZ-PIR EFS: 100% AZ-PIR STAT: <=91%

ZA-PIR EFS: 100% ZA-PIR STAT: <=91%

CURRENT HOUR 13:00 08-27-93

AZ-CVL : 1372261 AZ-ESL : 14

AZ-SESL: 0 AZ-UASL: 0

AZ-CVP : 1372261 AZ-ESP : 14

AZ-SESP: 0 AZ-UASP: 0

AZ-PDVS: 0 AZ-B8ZS: 0

AZ-MSEC: 0 AZ-STAT: 21

ZA-CVL : 358367 ZA-ESL : 3518

ZA-SESL: NA ZA-UASL: NA

ZA-CVP : 356959 ZA-ESP : 0

ZA-SESP: NA ZA-UASP: NA

ZA-PDVS: NA ZA-B8ZS: NA

ZA-MSEC: NA ZA-STAT: NA

HISTORY HOUR 01 12:00 08-27-93

AZ-CVL : 0 AZ-ESL : 08

.

.

.

Figure 6-4
SMART NIU Results Printout



Test Results Overflow

A results printout is automatically initiated when a result counter overflows. Labeled OVERFLOW PRINT, the printout also describes the reason for the overflow (see Figure 6-5). Each time a result counter overflows, the test result is preceded by a double

```

OVERFLOW PRINT 12:58:16 JAN 05
T1 ESF 1:7
BIT ERR**00014365 BIT E SEC 6516
BER 9.98 E-03 SLIPS 9
BPV ERR 0 BPV ER SEC 0
BPV RATE 0 E-07 FRA ER SEC N/A
FRA ERR N/A F E RATE N/A
CRC ERR 2148206 CRC ER SEC 6515
CRC E RT9.81 E-01 FREQ Hz 1543991
RX LEVEL+5.7 dBdsx RX LVL
11.61 Vp-p
SPX CUR 0 mA SIG LS SC 0
TEST LEN CONT ELAPS TIM 01:48:57
TEST END ****

CHANNEL RESULTS
CH. DROPPED 16
VF FREQ Hz 1004 VF LVL -15 dBm
DATA BITS01000000 SIG BITS 0101
SIGNALING BITS (ALL CHANNELS)
A: 000000 111111 000000 111111
B: 111111 000000 111111 000000
C: 000000 111111 000000 111111
D: 111111 000000 111111 000000

ALARM/STATUS
EX ZERO HIST ON T1 ON
PATTERN SYNC ON FRAME SYNC ON

```

Figure 6-5
Overflow Results Printout



asterisk (**) on the printout, indicating an *immediate overflow* condition (i.e., the results counter overflowed during the last second). Subsequent printouts of the overflowed result are preceded by a single asterisk (*) to indicate a *previous overflow* condition. All asterisks are cleared at test restart.

Printer Squelch Control

When 20 or more printouts are generated in 60 seconds, the printer squelch is turned on to temporarily halt the printouts. The squelched printouts include alarm, error, and severely errored second conditions that occur during a test. The twentieth printout indicates the squelch is turned on by printing the time-stamped message *PRINTER SQUELCH ON*. When the printouts drop to five or less in 60 seconds, the time-stamped message *PRINTER SQUELCH OFF* is printed and a squelch summary results printout (SQUELCH OFF PRINT) is generated. The squelch summary printout provides the cumulative results when the squelch was turned off. The printer squelch does not affect messages indicating the squelch state, timed print requests, manual print requests, or the *TEST COMPLETE* message. The printer squelch is reset when a restart occurs or at the end of a timed test.



6.5.2 Controls Printout

The controls printout lists the current setting of all front-panel switches and auxiliary functions. A controls printout is initiated manually using the AUX PRINT function. Figure 6-6 is an example of a controls printout.

```
CONTROLS PRINT 12:55:34 JAN 05
MODE T1 D4 PATTERN ALL ONES
TIMED/CONT CONT TEST LEN N/A
PRI EVE OFF PRI TIME N/A
TIMING INTERNAL CODE AMI
LOOP CODE CSU ESF LOOP IN BAND
LINE/PAY N/A RCV INPUT BRIDGE
PARITY NONE BAUD RATE 2400
CR/CR-LF CR-LF LBO 0dB
CH DROP 16
```

Figure 6-6
Controls Printout

6.5.3 Messages

When the AUX PRI EVNT function is set to ERROR, alarm and status messages are printed automatically to inform the operator of an important development related to the ongoing test. If the AUX PRI EVNT function is set to OFF, alarm and status messages are not printed automatically. All alarm and status messages are time- and date-stamped for easier mapping of problem sequences and trend analysis.

Possible messages are:

Alarm Messages

SIGLOSS XX—Loss of valid T1 pulses, where XX is a running count of signal losses since the last test restart.

FRAMLOSS XX—Loss of frame synchronization, where XX is a running count of frame sync losses since the last test restart.

PATTLOSS XX—Loss of pattern synchronization, where XX is a running count of pattern sync losses since the last test restart.

YELLOW ALM ON— A yellow alarm condition is present.

YELLOW ALM OFF— A yellow alarm condition is no longer present.

EX ZERO ON — More than 15 consecutive zeros have been received when the **B8ZS** switch is set to AMI (LED extinguished) or more than seven consecutive zeros have been detected when the **B8ZS** switch is set to B8ZS (LED illuminated).

EX ZERO OFF — Less than 16 consecutive zeros have been received when an excess zeros condition had been previously detected.

ONES DENSITY—The received data contains less than n ones in 8(n+1) bits, where n = 1 to 23.



AIS — Alarm Indication Signal (AIS) indicates an unframed T1 signal consisting of 2048 consecutive ones has been received.

Status Messages

SIGNAL DETECT — T1 pulses of valid frequency and level are present.

FRA SYNC ACQUIRED — The framing pattern has been detected and synchronization is acquired.

PATT SYNC ACQUIRED — The test pattern has been detected and synchronization is acquired.

B8ZS DETECTED — B8ZS line code is received.

NOT B8ZS COMPATIBLE — When the switch is set to the B8ZS position and the selected pattern is ALL ZERO, this message is displayed whenever the instrument receives the sequence 0001 1011, which occurs if a non-B8ZS compatible piece of equipment regenerates the transmitted signal.

BUFFER FULL — The internal print buffers have overflowed. At least one printout has been lost (discarded). Note that this is the only message that is not date- and time-stamped.

NOTE: Print buffer overflow may result in lost information.



PRINTER SQUELCH ON — More than 20 alarm or status prints have been generated within one minute. The printer squelch feature is enabled and no more messages or automatic ERR SEC results prints will print.

PRINTER SQUELCH OFF — Five or less print requests or errored second result printout requests have occurred within the last minute. The printer squelch feature is disabled and a summary printout is generated for the squelched printout time period.

TEST COMPLETE — The end of a timed test has been reached. This message applies only when in timed test mode.

TEST RESTART — A test restart has occurred.

NEW CONFIGURATION — The test configuration has been modified.



**SECTION
SPECIFICATIONS 7**

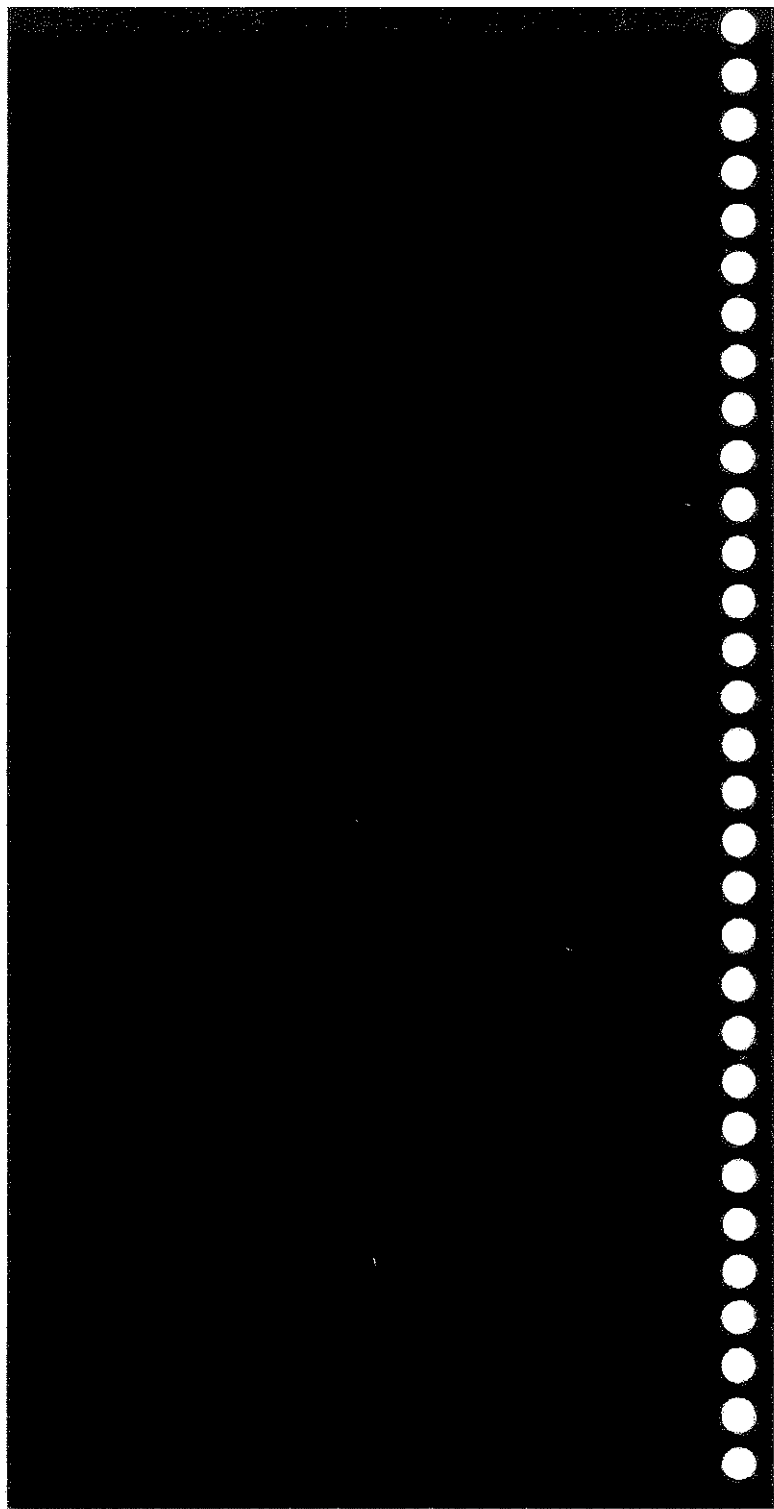



SPECIFICATIONS

7.1 INTRODUCTION

This section lists the specifications for the T-BERD 107A mainframe and options.

7.2 GENERAL SPECIFICATIONS

7.2.1 Physical

Size: 8.5"H x 4.25"W x 3.25"D
(21.6 cm x 10.8 cm x 8.3 cm).

Weight: 4.5 pounds (2.1 kg).

7.2.2 Operational

Operating Temperature: 32°F to 122°F (0°C to 50°C).

Storage Temperature: -40°F to 167°F (-40°C to 75°C).

Power

AC Adapter: 120 VAC to 12 VDC.

Battery: 12 VDC; lead-acid electrolyte.



7.3 INPUT SPECIFICATIONS

7.3.1 Receive Input (RX Jack)

| | |
|------------------|---------------------------------------|
| Input Connector: | Bantam jack. |
| Input Frequency: | 1,544,000 Hz \pm 4000 Hz. |
| Input Impedance | |
| BRIDGE: | 1000 Ω or greater (with ALBO). |
| TERM: | 100 Ω \pm 5% (with ALBO). |
| DSX-MON: | 100 Ω \pm 5% (with AGC). |
| Operating Range | |
| BRIDGE/TERM: | +6 to -35 dBdsx. |
| DSX-MON: | +6 to -24 dBdsx of resistive loss. |

7.3.2 T1 Reference Input (REF Jack)

| | |
|------------------|---------------------------------------|
| Input Connector: | Bantam jack. |
| Input Frequency: | 1,544,000 Hz \pm 1000 Hz. |
| Input Impedance: | 1000 Ω (nominal). |
| Operating Range: | +6 dBdsx to -24 dBdsx resistive loss. |

7.4 OUTPUT SPECIFICATIONS

7.4.1 Transmit Output (TX Jack)

Output Connector: Selectable line build-out (LBO) of 0, -7.5, -15.0, and -22.5 dB of cable loss at 772 Hz is provided on a bantam jack.

Output LBO
Tolerance: ± 1 dB at 772 kHz.

Internal Oscillator
Accuracy: ± 5 ppm.

Line Codes: AMI or B8ZS.

Error Insert: Single logic and BPV error insertion.

Pulse Shape: With output terminated in 100 Ω resistive load and 0 dB line build-out selected, the T-BERD 107A meets CCITT Recommendation G.703; AT&T Publications CB113, CB119, CB132, CB143, and PUB62508; and AT&T PUB62411 pulse shape specifications.



7.4.2 600 Ohm VF Output (VF OUT Jack)

| | |
|-------------------|--|
| Output Connector: | Bantam jack. |
| Output Frequency: | Voice frequency at 600 ohms impedance. |

7.5 MEASUREMENTS

7.5.1 Frequency

| | |
|-------------|--------------------------|
| Accuracy: | ± 5 ppm. |
| Resolution: | 1 Hz. |
| Range: | 1,544,000 \pm 5000 Hz. |

7.5.2 Level

The designation dBdsx is a voltage measurement; a 3-volt base-to-peak signal is defined as 0 dBdsx.

| | |
|--------------------|--|
| dBdsx Level Range: | +6 dBdsx to -40 dBdsx. |
| dBdsx Level: | ± 1 dB between +6 dBdsx and -Accuracy: 10 dBdsx. ± 2 dB between -10 dBdsx and -20 dBdsx. ± 3 dB between -20 dBdsx and -40 dBdsx. |



| | |
|-------------------|---|
| dBdsx Resolution: | 0.1 dB between +6 dBdsx and -6 dBdsx. 0.5 dB between -6 dBdsx and -40 dBdsx. |
| Vp-p Range: | 60 mV to 12.0 V. |
| Vp-p Resolution: | 0.1 V. |

7.5.3 Simplex Current

| | |
|-----------------------|-------------------------------|
| Range: | 10 mA to 180 mA. |
| Resolution: | 1 mA. |
| Accuracy: | ±5%. |
| Simplex Voltage Drop: | 8.5 volts (nominal) at 60 mA. |

7.5.4 Timing Slips

| | |
|-------------|---|
| Range: | -999 frame slips with -192 bit slips to +999 frame slips with +192 bit slips. |
| Resolution: | 1 bit slip. |
| Accuracy: | ±1 bit. |

**7.5.5 VF Frequency**

Range: 60 to 3904 Hz (+3.0 to -26.0 dBm).
60 to 3400 Hz (-27.0 to -40.0 dBm).

Resolution: 1 Hz.

Accuracy: ± 1 Hz.

7.5.6 VF Level

Range: +3.0 to -40 dBm.

Resolution: 0.1 dBm.

Accuracy: ± 0.5 dBm.

7.5.7 Channel Monitor

Channel: 1 to 24, NONE.

Signaling: T1 D1D, T1 D4, or T1 SLC—A and B signaling bits.
T1 ESF—A, B, C, and D signaling bits.

Data Presentation: Signaling bits for all 24 channels. Data bits for selected channel.

Table 7-1
 PRINTER Connector Pin Configuration

| Pin | Designation | Description |
|-----|-------------|---|
| 1 | +5V | +5 VDC. |
| 2 | GND | Ground—Common ground. |
| 3 | CHASSIS | Chassis ground—Connected to chassis ground. |
| 4 | TX Data | Transmit data—The T-BERD 107A receives data on this lead. |
| 5 | +5V | +5 VDC. |
| 6 | DTR | Data terminal ready—Data is only output from the T-BERD 107A when this line is held in the ON condition by the receiving device. |
| 7 | RX Data | Receive data—Data is transmitted by the T-BERD 107A on this lead. |
| 8 | DSR | Data set ready—This lead is driven to the ON state by the T-BERD 107A whenever it has power applied and is ready to receive data. |





7.6 CONNECTORS

7.6.1 PRINTER Connector

Output Connector: 9-pin DIN-type.

Connector Pin

Configuration: See Table 7-1.

7.7 ALARM CRITERIA

Signal Loss: 150ms without input pulses after valid frequency and level are detected.

Frame Loss

Mainframe Without

Options: D1D - 2 out of 5 F_1 bits in error.
D4 - 2 out of 5 F_1 bits in error.
ESF - 2 out of 5 frame bits in error.
SLC - 2 out of 5 F_1 bits in error.

SLC Datalink Decode

Option Installed: D1D - 2 out of 4 F_1 bits in error.
D4 - 2 out of 4 F_1 bits in error.
ESF - 2 out of 4 frame bits in error.
SLC - 2 out of 4 F_1 bits in error.

SECTION 7  SPECIFICATIONS

| | |
|--------------------------------|---|
| Pattern Loss: | QRSS — 250 errors detected in 1000 or fewer bits. Fixed pattern — 100 errors in 1000 or fewer bits. |
| Ones Density: | QRSS — LED illumination is suppressed. Other patterns — received data contains less than n ones in 8(n+1) bits, where n = 1 to 23. |
| Excess Zeros: | AMI - 16 or more consecutive zeros. B8ZS - 8 or more consecutive zeros. |
| Yellow Alarm: | D1D - Bit 2 is a 0 for 255 consecutive channels. D4 - Bit 2 is a 0 for 255 consecutive channels. ESF - 256 bits ±16 bits of a repetitive (1111 1111 0000 0000) pattern received in the 4 kb/s datalink. SLC - Bit 2 is a 0 for 255 consecutive channels. |
| AIS (Alarm Indication Signal): | Unframed T1 signal has 2048 consecutive ones. |



Low Battery: Battery has approximately 15 minutes of power remaining.

7.8 PATTERN SPECIFICATIONS

7.8.1 Pattern Definition

ALL ONES: All ones.

1:1: Alternating ones and zeros.

1:7: F01000000—Pattern is aligned with framing (F) patterns as indicated.

2 IN 8: F01000010—Pattern is aligned with framing (F) patterns as indicated.

3 IN 24: F0100 0100 0000 0000 0000 0100—Pattern is aligned with framing (F) patterns as indicated.

T1-QRSS: QRSS pattern ($2^{20}-1$ with zero suppression).

BRIDGTAP: Automated 21-pattern sequence with varying degrees of ones and zeros density that detect bridge taps (see Section 3.2 Mainframe — Test Setup).



| | |
|-----------|--|
| MULTIPAT: | Automated 5-pattern sequence that includes: ALL ONES, 1:7, 2 IN 8, 3 IN 24, and QRSS (see Section 3.2 Mainframe — Test Setup). |
| ALL ZERO: | AMI coding - all zeros, no pulses except framing. B8ZS coding - B8ZS BPV sequence 000V 10V1 (V = bipolar violation). |
| 1000 Hz: | Digital milliwatt signal. |
| T1 DALY: | Optional 55-byte fixed long pattern. |
| T1-2/96: | Optional 96-byte fixed long pattern. |
| T1-3/54: | Optional unframed 54-byte fixed long pattern. |
| T1-4/120: | Optional 120-byte fixed long pattern. |
| T1-5/53: | Optional unframed 53-byte fixed long pattern. |
| 55 OCTET: | Optional unframed 55-byte fixed long pattern. |
| MIN/MAX: | Optional 72-byte fixed long pattern. |



7.8.2 Pattern Sync Detection Criteria

Fixed Patterns: 30 consecutive error-free bits.

QRSS: 30 + n consecutive error-free bits for a pattern length of $2^n - 1$.

7.9 LOOP CODES

7.9.1 Generation and Detection Patterns

CSULoop Codes

INBAND: Loop up: 10000; loop down: 100.

ESFLINE: Loopup: 1111 1111 0111 0000; loop down: 1111 1111 0001 1100.

ESF PAYLOAD :loop up: 1111 1111 0010 1000; loop down: 1111 1111 0100 1100.

NIULoop Codes

FAC1: Loop up: 1100; loop down: 1110.

FAC2: Loop up: 11000; loop down: 11100.

FAC3: Loop up: 100000; loop down: 100 (N.E. Tel.).

ESFNET: Loopup: 1111 1111 0100 1000; loop down: 1111 1111 0010 0100.

PROGLoop Codes

PGMLPUP: 3- to 8-bit repeating code. Factory default (FAC1): loop up - 1100.



PGMLPDN: 3- to 8-bit repeating code. Factory default (FAC1): loop down - 1110.

NOTE: Generated codes may be sent unframed or framed. When framed is selected, in-band loop codes are overwritten by the framing bit.

7.9.2 Loop Detect Criteria

In-Band Loop

Codes: At least 177 error-free bits of the selected repetitive pattern must be received (loop up and loop down).

Out-of-Band Loop

Codes: Datalink monitored every 125 ms for loop codes (loop up and loop down).

7.10 GROUNDING

Bantam Jacks: Sleeves connected to chassis ground.

RS-232 8-Pin

DIN Connector: Pin 3 to chassis ground.
Pin 2 to common ground.



7.11 BATTERY

- Type: 12 V, lead-acid electrolyte.
- Operating Period: Typically provides four hours of continuous operation on a full charge.
- Storage Period: @ 68°F, holds 85% of charge after six months. Requires recharging every six months.
- Recharging Period: Minimum of eight hours from full discharge if test set is turned off.

**APPENDIX
FACTORY DEFAULT
SETTINGS**

A

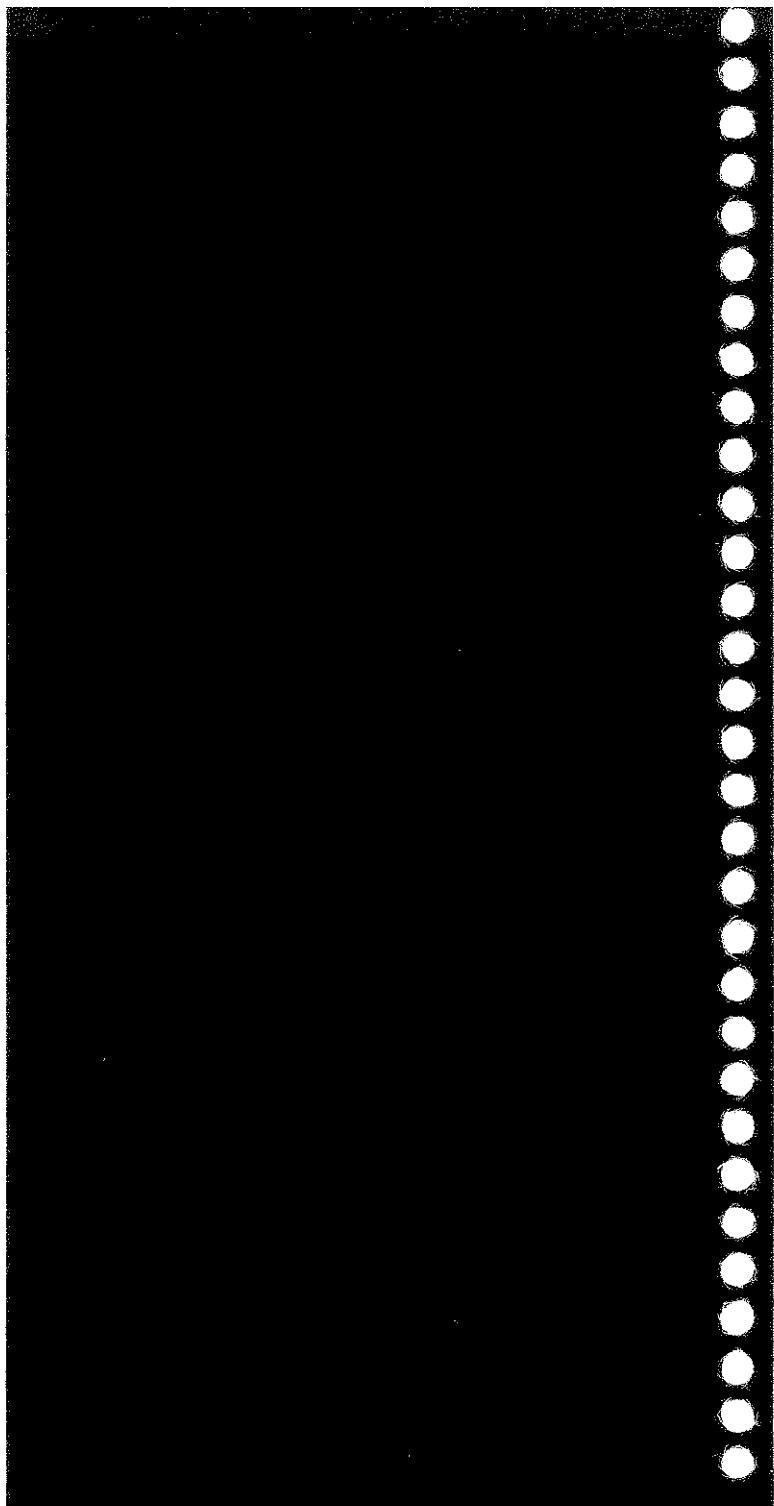

FACTORY DEFAULT SETTINGS

A.1 DEFAULT SETTINGS

This appendix contains the factory default settings (see Table A-1) that are stored in nonvolatile RAM (NOVRAM). The T-BERD 107A controls can be forced to their default settings by pressing and holding down the **RESTART** switch while the unit is being powered-up. As soon as the message *SYSTEM RESET* is visible in the display window, release the **RESTART** switch.

Table A-1
Factory Default Settings

| Parameter | Default |
|------------|---------------------------|
| B8ZS | LED OFF (AMI coding) |
| DISPLLIGHT | OFF |
| LBO | 0 dB |
| LOOP CODES | CSU |
| MODE | SELF TST |
| PATTERN | ALL ONES |
| RX INPUT | BRIDGE |
| RECVD | LED OFF (internal timing) |
| AUX | LED OFF |
| CATEGORY | SUMMARY |
| AUXUSER1 | 010100100 |
| AUXUSER2 | 001101110 |
| AUXUSER3 | 110001110 |

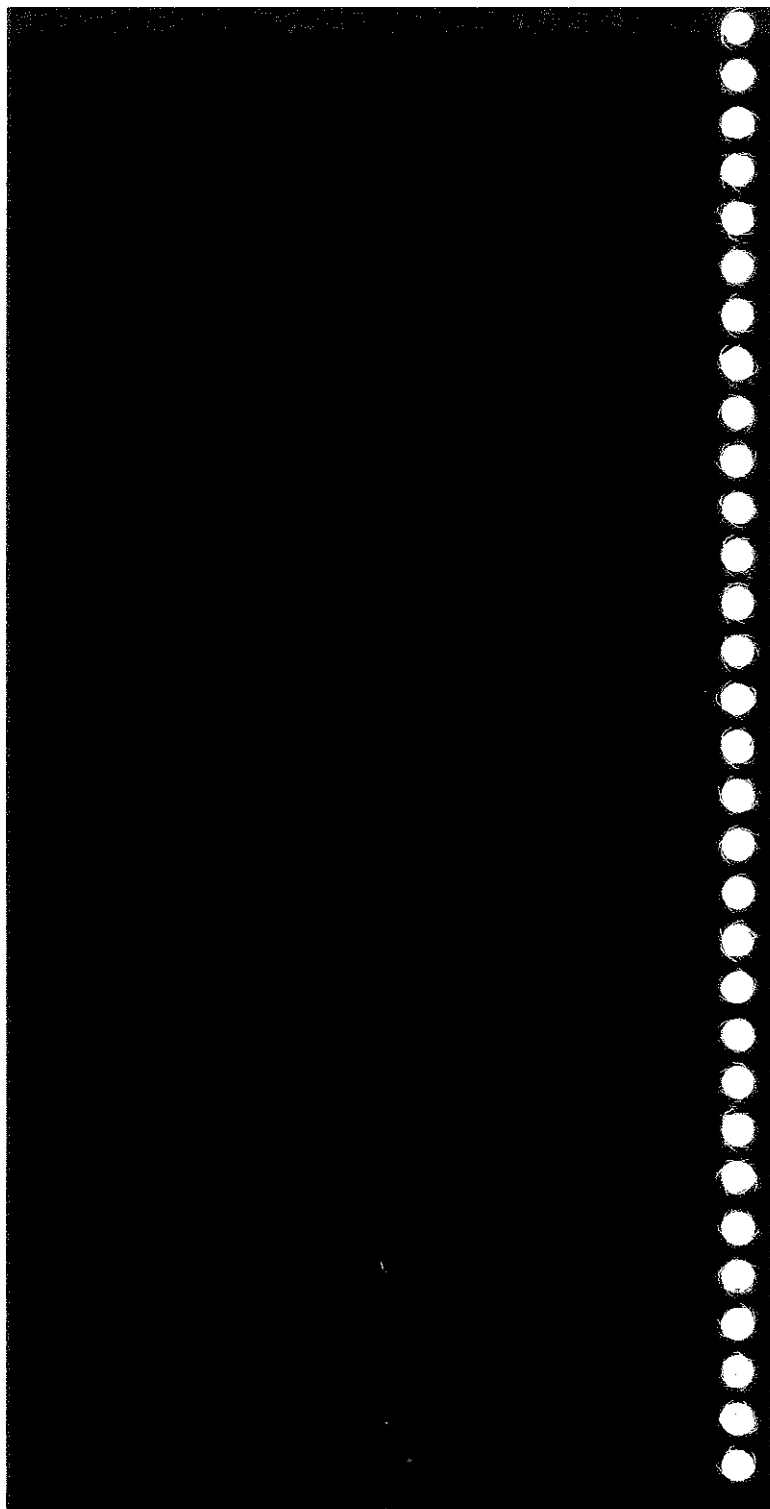

Table A-1
Factory Default Settings (Continued)

| Parameter | Default |
|------------------------|---------------------|
| AUXMULTIPAT PATTERN | ALL ONES |
| TIME | 3:00 (all patterns) |
| AUXPGMLPUP | 1100 (FAC1) |
| AUXPGMLPDN | 1110 (FAC1) |
| AUXAUORESP | NORESPONSE |
| AUXLOOPCODE | |
| (CSU) | IN BAND |
| (NIU) | FAC2 |
| (PROG) | USER |
| AUXSMARTNET | TELTREND 7321 |
| AUXDATALINK | |
| BPMRCVR | ON |
| USER BPM | 01100110 |
| PRMTRAN | OFF |
| PRMRCVR | ON |
| AUXFT1 IDLE | 11111111 |
| AUXFT1 RATE | 64KXN |
| AUXFT1 CHAN | 1 |
| AUXVF TONE | 1004HzxN |
| AUXVF CHAN | NONE |
| AUXVOLUME | OFF |
| AUX TIME TST | CONTINUOUS |
| AUX TEST LEN | 200 HRS 00 MIN |
| AUXPRINT | N/A |
| AUX BUF CLR | N/A |
| AUX PRI EVNT | OFF |
| AUX PRI INTV | 12 HRS 00 MIN |
| AUXPRNTPORT | |
| BAUD RATE | 2400 |
| PARITY | NONE |
| TERM 232 | CR |
| AUX CLOCK | N/A |

**APPENDIX
CHANNEL TIME
SLOT ASSIGNMENTS**

B





CHANNEL TIME SLOT ASSIGNMENTS

This appendix features a table of channel time slot assignments for all T1 framing formats offered by the T-BERD 107A.

B.1 CHANNEL TIME SLOT ASSIGNMENTS

The channel time slot assignments determine which channel is actually dropped from a framed signal when a particular time slot is selected. Since the T-BERD 107A selects the dropped channel based on the primary usage of D4 and ESF framing, the time slots for other D1D and SLC framing drop different data channels than the user may expect. Use Table B-1 to determine the correspondence between the selected channel number and the actual timeslot that is displayed.

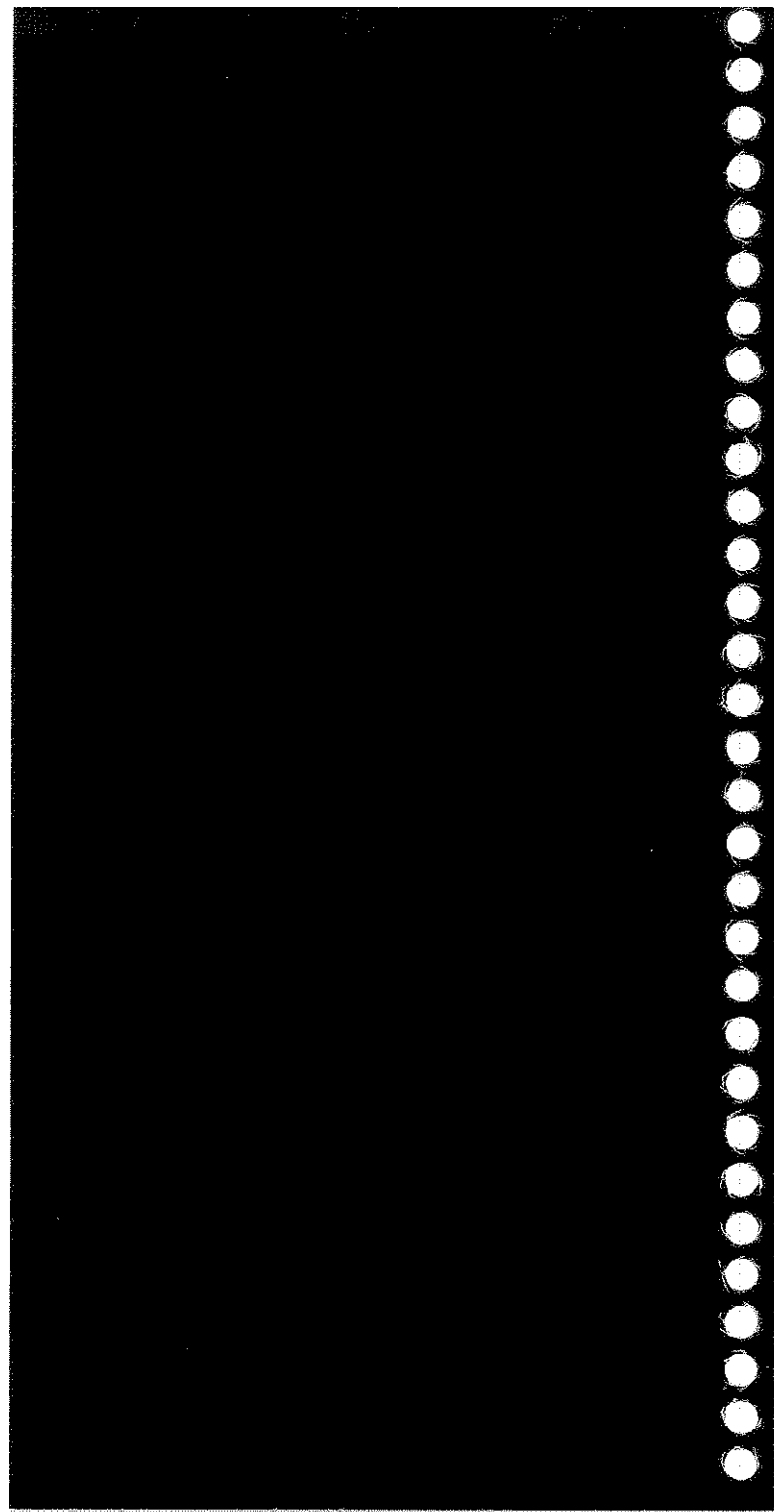

Table B-1
Channel Time Slot Assignments

| Time Slot | D1D Channel Number | D4 & ESF Channel Number | SLC Channel Number |
|-----------|--------------------|-------------------------|--------------------|
| 1 | 1 | 1 | 1 |
| 2 | 13 | 2 | 13 |
| 3 | 2 | 3 | 2 |
| 4 | 14 | 4 | 14 |
| 5 | 3 | 5 | 3 |
| 6 | 15 | 6 | 15 |
| 7 | 4 | 7 | 4 |
| 8 | 16 | 8 | 16 |
| 9 | 5 | 9 | 5 |
| 10 | 17 | 10 | 17 |
| 11 | 6 | 11 | 6 |
| 12 | 18 | 12 | 18 |
| 13 | 7 | 13 | 7 |
| 14 | 19 | 14 | 19 |
| 15 | 8 | 15 | 8 |
| 16 | 20 | 16 | 20 |
| 17 | 9 | 17 | 9 |
| 18 | 21 | 18 | 21 |
| 19 | 10 | 19 | 10 |
| 20 | 22 | 20 | 22 |
| 21 | 11 | 21 | 11 |
| 22 | 23 | 22 | 23 |
| 23 | 12 | 23 | 12 |
| 24 | 24 | 24 | 24 |

**APPENDIX
STRESS
PATTERNS**

C





STRESS PATTERNS

The stress patterns are represented in a right-to-left format. When the pattern is transmitted in binary form the least significant bit is transmitted first. This requires that the binary representation be turned over for transmission. Example: The binary representation of the hexadecimal value 01 would be 0000 0001. When transmitted least significant bit first, it would be transmitted 1000 0000 (left-to-right).

Hexadecimal-to-Binary Conversion

| H | 8421 |
|---|------|
| 0 | 0000 |
| 1 | 0001 |
| 2 | 0010 |
| 3 | 0011 |
| 4 | 0100 |
| 5 | 0101 |
| 6 | 0110 |
| 7 | 0111 |
| 8 | 1000 |
| 9 | 1001 |
| A | 1010 |
| B | 1011 |
| C | 1100 |
| D | 1101 |
| E | 1110 |
| F | 1111 |

MSB LSB
74H = 0111 0100



Min/Max Stress Pattern

| | | | | | | | | | |
|----------|----------|----------|----------|----------|----------|----------|----------|----------|----------|
| 01 | 02 | 03 | 04 | 05 | 06 | 07 | 08 | 09 | 10 |
| 80H | 80H | 80H | 80H | 01H | 00H | 01H | 01H | 01H | 03H |
| 10000000 | 10000000 | 10000000 | 10000000 | 00000001 | 00000000 | 00000000 | 00000001 | 00000001 | 00000011 |
| 11 | 12 | 13 | 14 | 15 | 16 | 17 | 18 | 19 | 20 |
| 80H | 01H | 80H | 01H | 01H | 80H | 01H | 22H | 00H | 20H |
| 10000000 | 00000001 | 10000000 | 00000001 | 00000001 | 10000000 | 00000001 | 00100010 | 00000000 | 00100000 |
| 21 | 22 | 23 | 24 | 25 | 26 | 27 | 28 | 29 | 30 |
| 22H | 00H | 20H | AAH | AAH | AAH | AAH | AAH | 55H | 55H |
| 00100010 | 00000000 | 00100000 | 10101010 | 10101010 | 10101010 | 10101010 | 10101010 | 10101010 | 01010101 |
| 31 | 32 | 33 | 34 | 35 | 36 | 37 | 38 | 39 | 40 |
| 55H | 55H | AAH | AAH | AAH | AAH | 55H | AAH | AAH | 55H |
| 01010101 | 01010101 | 10101010 | 10101010 | 10101010 | 10101010 | 01010101 | 10101010 | 10101010 | 01010101 |





Min/Max Stress Pattern (Continued)

| | | | | | | | | | |
|----------|----------|----------|----------|----------|----------|----------|----------|----------|----------|
| 41 | 42 | 43 | 44 | 45 | 46 | 47 | 48 | 49 | 50 |
| 55H | 55H | 80H | 80H | FFH | FFH | FFH | FFH | FFH | FFH |
| 01010101 | 01010101 | 10000000 | 10000000 | 11111111 | 11111111 | 11111111 | 11111111 | 11111111 | 11111111 |
| 51 | 52 | 53 | 54 | 55 | 56 | 57 | 58 | 59 | 60 |
| FFH | FEH | FFH | FFH | 24H | 49H | 92H | 88H | 88H | 88H |
| 11111111 | 11111110 | 11111111 | 11111111 | 00100100 | 01001001 | 10010010 | 10001000 | 10001000 | 10001000 |
| 61 | 62 | 63 | 64 | 65 | 66 | 67 | 68 | 69 | 70 |
| 10H | 42H | 08H | 21H | 84H | 20H | 08H | 82H | 40H | 20H |
| 00010000 | 01000010 | 00001000 | 00100001 | 10000100 | 00100000 | 00001000 | 10000010 | 01000000 | 00100000 |
| 71 | 72 | 73 | | | | | | | |
| 10H | 80H | -- | | | | | | | |
| 00010000 | 10000000 | | | | | | | | |



T1-2 Stress Pattern

| | | | | | | | | | |
|---------|---------|---------|---------|---------|---------|---------|---------|---------|---------|
| 01 | 02 | 03 | 04 | 05 | 06 | 07 | 08 | 09 | 10 |
| FFH | FFH | FFH | FFH | FFH | FFH | FFH | FFH | FFH | FFH |
| 1111111 | 1111111 | 1111111 | 1111111 | 1111111 | 1111111 | 1111111 | 1111111 | 1111111 | 1111111 |
| 11 | 12 | 13 | 14 | 15 | 16 | 17 | 18 | 19 | 20 |
| FFH | FFH | FFH | FFH | FFH | FFH | FFH | FFH | FFH | FFH |
| 1111111 | 1111111 | 1111111 | 1111111 | 1111111 | 1111111 | 1111111 | 1111111 | 1111111 | 1111111 |
| 21 | 22 | 23 | 24 | 25 | 26 | 27 | 28 | 29 | 30 |
| FFH | FFH | FFH | FFH | FFH | FFH | FFH | FFH | FFH | FFH |
| 1111111 | 1111111 | 1111111 | 1111111 | 1111111 | 1111111 | 1111111 | 1111111 | 1111111 | 1111111 |
| 31 | 32 | 33 | 34 | 35 | 36 | 37 | 38 | 39 | 40 |
| FFH | FFH | FFH | FFH | FFH | FFH | FFH | FFH | FFH | FFH |
| 1111111 | 1111111 | 1111111 | 1111111 | 1111111 | 1111111 | 1111111 | 1111111 | 1111111 | 1111111 |





T1-2 Stress Pattern (Continued)

| | | | | | | | | | | | | | | | | | | | | | | | | | | | | | |
|----|-----|----------|----|-----|----------|----|-----|----------|----|-----|----------|----|-----|----------|----|-----|----------|----|-----|----------|----|-----|----------|----|-----|----------|----|-----|----------|
| 41 | FFH | 11111111 | 42 | FFH | 11111111 | 43 | FFH | 11111111 | 44 | FFH | 11111111 | 45 | FFH | 11111111 | 46 | FFH | 11111111 | 47 | FFH | 11111111 | 48 | FFH | 11111111 | 49 | AAH | 10101010 | 50 | AAH | 10101010 |
| 51 | AAH | 10101010 | 52 | AAH | 10101010 | 53 | 80H | 10000000 | 54 | 01H | 00000000 | 55 | 80H | 10000000 | 56 | 01H | 00000000 | 57 | 80H | 10000000 | 58 | 01H | 00000000 | 59 | 80H | 10000000 | 60 | 01H | 00000000 |
| 61 | 80H | 10000000 | 62 | 01H | 00000000 | 63 | 80H | 10000000 | 64 | 01H | 00000000 | 65 | 80H | 10000000 | 66 | 01H | 00000000 | 67 | 80H | 10000000 | 68 | 01H | 00000000 | 69 | 80H | 10000000 | 70 | 01H | 00000000 |
| 71 | 80H | 10000000 | 72 | 01H | 00000000 | 73 | AAH | 10101010 | 74 | AAH | 10101010 | 75 | AAH | 10101010 | 76 | AAH | 10101010 | 77 | 80H | 10000000 | 78 | 01H | 00000000 | 79 | 80H | 10000000 | 80 | 01H | 00000000 |



C-6

T1-2 Stress Pattern (Continued)

| | | | | | | | | | |
|----------|----------|----------|----------|----------|----------|----------|----------|----------|----------|
| 81 | 82 | 83 | 84 | 85 | 86 | 87 | 88 | 89 | 90 |
| H08 | 01H | 80H | 01H | 80H | 01H | 80H | 01H | 80H | 01H |
| 10000000 | 00000001 | 10000000 | 00000000 | 10000000 | 00000000 | 10000000 | 00000000 | 10000000 | 00000000 |
| 91 | 92 | 93 | 94 | 95 | 96 | | | | |
| H08 | 01H | 80H | 01H | 80H | 01H | | | | |
| 10000000 | 00000001 | 10000000 | 00000000 | 10000000 | 00000000 | | | | |





T13 Stress Pattern

| | | | | | | | | | |
|----------|----------|----------|----------|----------|----------|----------|----------|----------|----------|
| 01 | 02 | 03 | 04 | 05 | 06 | 07 | 08 | 09 | 10 |
| 01H | 01H | 01H | 01H | 01H | 01H | 00H | 01H | 01H | 01H |
| 00000001 | 00000001 | 00000001 | 00000001 | 00000001 | 00000001 | 00000000 | 00000000 | 00000001 | 00000001 |
| 11 | 12 | 13 | 14 | 15 | 16 | 17 | 18 | 19 | 20 |
| 01H | 01H | 01H | 03H | 01H | 01H | 01H | 01H | 07H | 01H |
| 10000000 | 00000001 | 00000001 | 00000001 | 00000011 | 00000001 | 00000001 | 00000001 | 00000111 | 00000001 |
| 21 | 22 | 23 | 24 | 25 | 26 | 27 | 28 | 29 | 30 |
| 01H | 01H | 01H | 55H | 55H | 55H | 55H | AAH | AAH | AAH |
| 00000001 | 00000001 | 00000001 | 01010101 | 01010101 | 01010101 | 01010101 | 10101010 | 10101010 | 10101010 |
| 31 | 32 | 33 | 34 | 35 | 36 | 37 | 38 | 39 | 40 |
| AAH | 01H | 01H | 01H | 01H | 01H | 01H | FFH | FFH | FFH |
| 10101010 | 00000001 | 00000001 | 00000001 | 00000001 | 00000001 | 00000001 | 11111111 | 11111111 | 11111111 |



T1-3 Stress Pattern

| | | | | | | | | | | | | | | | | | | | | | | | | | | | | | |
|----|-----|----------|----|-----|----------|----|-----|----------|----|-----|----------|----|-----|----------|----|-----|----------|----|-----|----------|----|-----|----------|----|-----|----------|----|-----|----------|
| 41 | FFH | 11111111 | 42 | FFH | 11111111 | 43 | FFH | 11111111 | 44 | 80H | 10000000 | 45 | 01H | 00000000 | 46 | 80H | 10000000 | 47 | 01H | 00000000 | 48 | 80H | 10000000 | 49 | 01H | 00000000 | 50 | 80H | 10000000 |
| 51 | 01H | 00000001 | 52 | 80H | 10000000 | 53 | 01H | 00000000 | 54 | 80H | 10000000 | | | | | | | | | | | | | | | | | | |





T14 Stress Pattern

| | | | | | | | | | |
|----------|----------|----------|----------|----------|----------|----------|----------|----------|----------|
| 01 | 02 | 03 | 04 | 05 | 06 | 07 | 08 | 09 | 10 |
| FFH | FFH | FFH | FFH | FFH | FFH | FFH | FFH | FFH | FFH |
| 11111111 | 11111111 | 11111111 | 11111111 | 11111111 | 11111111 | 11111111 | 11111111 | 11111111 | 11111111 |
| 11 | 12 | 13 | 14 | 15 | 16 | 17 | 18 | 19 | 20 |
| FFH | FFH | FFH | FFH | FFH | FFH | FFH | FFH | FFH | FFH |
| 11111111 | 11111111 | 11111111 | 11111111 | 11111111 | 11111111 | 11111111 | 11111111 | 11111111 | 11111111 |
| 21 | 22 | 23 | 24 | 25 | 26 | 27 | 28 | 29 | 30 |
| FFH | FFH | FFH | FFH | FFH | FFH | FFH | FFH | FFH | FFH |
| 11111111 | 11111111 | 11111111 | 11111111 | 11111111 | 11111111 | 11111111 | 11111111 | 11111111 | 11111111 |
| 31 | 32 | 33 | 34 | 35 | 36 | 37 | 38 | 39 | 40 |
| FFH | FFH | FFH | FFH | FFH | FFH | FFH | FFH | FFH | FFH |
| 11111111 | 11111111 | 11111111 | 11111111 | 11111111 | 11111111 | 11111111 | 11111111 | 11111111 | 11111111 |



T1-4 Stress Pattern(Continued)

| | | | | | | | | | |
|----------|----------|----------|----------|----------|----------|----------|----------|----------|----------|
| 41 | 42 | 43 | 44 | 45 | 46 | 47 | 48 | 49 | 50 |
| FFH | FFH | FFH | FFH | FFH | FFH | FFH | FFH | FFH | FFH |
| 11111111 | 11111111 | 11111111 | 11111111 | 11111111 | 11111111 | 11111111 | 11111111 | 11111111 | 11111111 |
| 51 | 52 | 53 | 54 | 55 | 56 | 57 | 58 | 59 | 60 |
| FFH | FFH | FFH | FFH | FFH | FFH | FFH | FFH | FFH | FFH |
| 11111111 | 11111111 | 11111111 | 11111111 | 11111111 | 11111111 | 11111111 | 11111111 | 11111111 | 11111111 |
| 61 | 62 | 63 | 64 | 65 | 66 | 67 | 68 | 69 | 70 |
| FFH | FFH | FFH | FFH | FFH | FFH | FFH | FFH | FFH | FFH |
| 11111111 | 11111111 | 11111111 | 11111111 | 11111111 | 11111111 | 11111111 | 11111111 | 11111111 | 11111111 |
| 71 | 72 | 73 | 74 | 75 | 76 | 77 | 78 | 79 | 80 |
| FFH | FFH | AAH | AAH | AAH | AAH | 10H | 10H | 10H | 10H |
| 11111111 | 11111111 | 10101010 | 10101010 | 10101010 | 10101010 | 00010000 | 00010000 | 00010000 | 00010000 |





T14 Stress Pattern (Continued)

| | | | | | | | | | |
|-----------|-----------|-----------|-----------|-----------|-----------|-----------|-----------|-----------|-----------|
| 891 | 82 | 83 | 84 | 85 | 86 | 87 | 88 | 89 | 90 |
| 10H | 10H | 10H | 10H | 10H | 10H | 10H | 10H | 10H | 10H |
| 0001 0000 | 0001 0000 | 0001 0000 | 0001 0000 | 0001 0000 | 0001 0000 | 0001 0000 | 0001 0000 | 0001 0000 | 0001 0000 |
| 91 | 92 | 93 | 94 | 95 | 96 | 97 | 98 | 99 | 100 |
| 10H | 10H | 10H | 10H | 10H | 10H | AAH | AAH | AAH | AAH |
| 0001 0000 | 0001 0000 | 0001 0000 | 0001 0000 | 0001 0000 | 0001 0000 | 1010 1010 | 1010 1010 | 1010 1010 | 1010 1010 |
| 101 | 102 | 103 | 104 | 105 | 106 | 107 | 108 | 109 | 110 |
| 10H | 10H | 10H | 10H | 10H | 10H | 10H | 10H | 10H | 10H |
| 0001 0000 | 0001 0000 | 0001 0000 | 0001 0000 | 0001 0000 | 0001 0000 | 0001 0000 | 0001 0000 | 0001 0000 | 0001 0000 |
| 111 | 112 | 113 | 114 | 115 | 116 | 117 | 118 | 119 | 120 |
| 10H | 10H | 10H | 10H | 10H | 10H | 10H | 10H | 10H | 10H |
| 0001 0000 | 0001 0000 | 0001 0000 | 0001 0000 | 0001 0000 | 0001 0000 | 0001 0000 | 0001 0000 | 0001 0000 | 0001 0000 |



T1-5 Stress Pattern

| | | | | | | | | | |
|----------|----------|----------|----------|----------|----------|----------|----------|----------|----------|
| 01 | 02 | 03 | 04 | 05 | 06 | 07 | 08 | 09 | 10 |
| 80H | 01H | 80H | 01H | 80H | 01H | 80H | 01H | 80H | 01H |
| 10000000 | 00000001 | 10000000 | 00000001 | 10000000 | 00000001 | 10000000 | 00000001 | 10000000 | 00000001 |
| 11 | 12 | 13 | 14 | 15 | 16 | 17 | 18 | 19 | 20 |
| 80H | 01H | 80H | 01H | 80H | 01H | 80H | 01H | 80H | 01H |
| 10000000 | 00000001 | 10000000 | 00000001 | 10000000 | 00000001 | 10000000 | 00000001 | 10000000 | 00000001 |
| 21 | 22 | 23 | 24 | 25 | 26 | 27 | 28 | 29 | 30 |
| 80H | 01H | 80H | 01H | 80H | 01H | 80H | 01H | 80H | 01H |
| 10000000 | 00000001 | 10000000 | 00000001 | 10000000 | 00000001 | 10000000 | 00000001 | 10000000 | 00000001 |





T1-8 Stress Pattern

| | | | | | | | | | |
|----------|----------|----------|----------|----------|----------|----------|----------|----------|----------|
| 01 | 02 | 03 | 04 | 05 | 06 | 07 | 08 | 09 | 10 |
| 01H | 01H | 01H | 01H | 01H | 01H | 00H | 01H | 01H | 01H |
| 00000001 | 00000001 | 00000001 | 00000001 | 00000001 | 00000001 | 00000000 | 00000001 | 00000001 | 00000001 |
| 11 | 12 | 13 | 14 | 15 | 16 | 17 | 18 | 19 | 20 |
| 01H | 01H | 01H | 03H | 01H | 01H | 01H | 01H | 07H | 01H |
| 00000001 | 00000001 | 00000001 | 00000011 | 00000001 | 00000001 | 00000001 | 00000001 | 00000111 | 00000001 |
| 21 | 22 | 23 | 24 | 25 | 26 | 27 | 28 | 29 | 30 |
| 01H | 01H | 01H | 55H | 55H | 55H | 55H | AAH | AAH | AAH |
| 00000001 | 00000001 | 00000001 | 01010101 | 01010101 | 01010101 | 01010101 | 10101010 | 10101010 | 10101010 |
| 31 | 32 | 33 | 34 | 35 | 36 | 37 | 38 | 39 | 40 |
| AAH | 01H | 01H | 01H | 01H | 01H | 01H | FFH | FFH | FFH |
| 10101010 | 00000001 | 00000001 | 00000001 | 00000001 | 00000001 | 00000001 | 11111111 | 11111111 | 11111111 |





T16 Stress Pattern (Continued)

| | | | | | | | | | |
|----------|----------|----------|----------|----------|----------|----------|----------|----------|----------|
| 41 | 42 | 43 | 44 | 45 | 46 | 47 | 48 | 49 | 50 |
| FFH | FFH | FFH | 80H | 01H | 80H | 01H | 80H | 01H | 80H |
| 11111111 | 11111111 | 11111111 | 11111111 | 10000000 | 00000001 | 10000000 | 00000001 | 10000000 | 00000001 |
| | | | | | | | | | 10000000 |
| 51 | 52 | 53 | 54 | 55 | | | | | |
| 01H | 80H | 01H | 80H | 01H | | | | | |
| 00000001 | 10000000 | 00000001 | 10000000 | 00000001 | | | | | |



TIDALY Stress Pattern

| | | | | | | | | | |
|----------|----------|----------|----------|----------|----------|----------|----------|----------|----------|
| 01 | 02 | 03 | 04 | 05 | 06 | 07 | 08 | 09 | 10 |
| 01H | 01H | 01H | 01H | 01H | 01H | 80H | 01H | 01H | 01H |
| 00000001 | 00000001 | 00000001 | 00000001 | 00000001 | 00000001 | 10000000 | 00000001 | 00000001 | 00000001 |
| 11 | 12 | 13 | 14 | 15 | 16 | 17 | 18 | 19 | 20 |
| 01H | 01H | 01H | 03H | 01H | 01H | 01H | 01H | 07H | 01H |
| 00000001 | 00000001 | 00000001 | 00000011 | 00000001 | 00000001 | 00000001 | 00000001 | 00000111 | 00000001 |
| 21 | 22 | 23 | 24 | 25 | 26 | 27 | 28 | 29 | 30 |
| 01H | 01H | 01H | 55H | 55H | 55H | 55H | AAH | AAH | AAH |
| 00000001 | 00000001 | 00000001 | 01010101 | 01010101 | 01010101 | 01010101 | 10101010 | 10101010 | 10101010 |
| 31 | 32 | 33 | 34 | 35 | 36 | 37 | 38 | 39 | 40 |
| AAH | 01H | 01H | 01H | 01H | 01H | 01H | FFH | FFH | FFH |
| 10101010 | 00000001 | 00000001 | 00000001 | 00000001 | 00000001 | 00000001 | 11111111 | 11111111 | 11111111 |





T1-DALY Stress Pattern (Continued)

| | | | | | | | | | |
|----------|----------|----------|----------|----------|----------|----------|----------|----------|----------|
| 41 | 42 | 43 | 44 | 45 | 46 | 47 | 48 | 49 | 50 |
| FFH | FFH | FFH | 80H | 01H | 80H | 01H | 80H | 01H | 80H |
| 11111111 | 11111111 | 11111111 | 10000000 | 00000001 | 10000000 | 00000001 | 10000000 | 00000001 | 10000000 |
| 51 | 52 | 53 | 54 | 55 | | | | | |
| 01H | 80H | 01H | 80H | 01H | | | | | |
| 00000001 | 10000000 | 00000001 | 10000000 | 00000001 | | | | | |





**APPENDIX
INTELLIGENT
NETWORK EQUIPMENT **D****

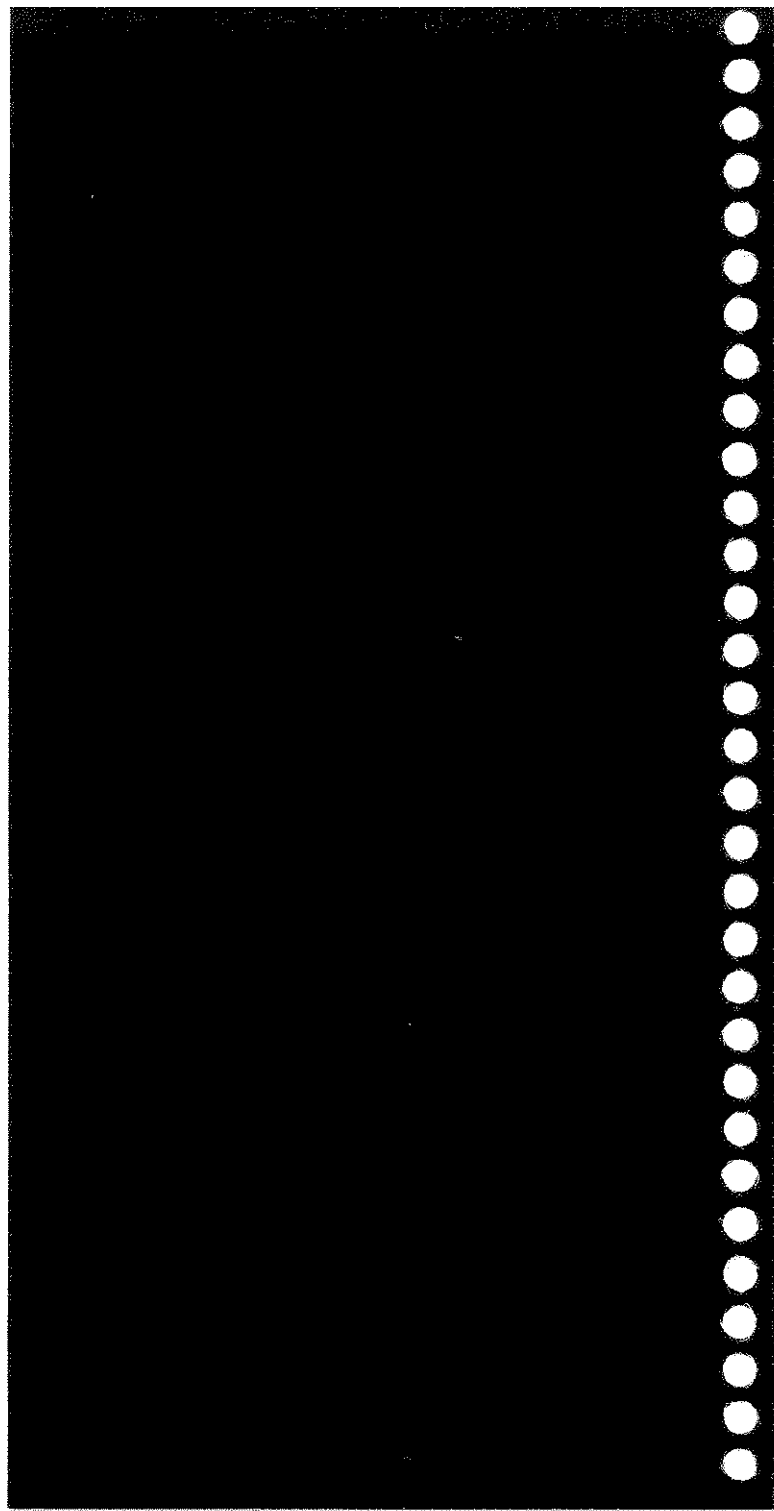

Intelligent Network Equipment

INTRODUCTION

This appendix shows the intelligent network equipment addresses (see Table D-1) and available commands (see Table D-2) currently supported by the T-BERD 107A Smart Loopback/Command Codes Option.

Table D-1
Intelligent Network Equipment Loop Code Addresses

| Equip. Manuf. | Model | IOR Addresses | ILR Addresses | Maint. Switch/ Ramp Address |
|---------------|-------------------------|---------------|---------------|--------------------------------|
| ADTRAN | HDSL equip. No Model # | None | 1 to 2 | N/A |
| Pair Gain | HDSL equip. No Model # | None | 1 to 2 | N/A |
| Tellabs | HDSL equip. No Model # | None | 1 to 2 | N/A |
| Teltrend | 7231/7239, 7231/7239 LC | None | 1 to 20 | N/A |
| | 7231/7239 LD | | | |
| | 7231/7239 LP | | | |
| | 7231/7239 LS | | | |
| | 7231/7239 LW | | | |
| | 7231 E | 1 to 3 | N/A | N/A |
| | DSI Maintenance Switch | N/A | N/A | 1 to 16 |
| TxFPORT | 231/239 | 1 to 26 | 1 to 26 | N/A |



Table D-1 (Continued)
Intelligent Network Equipment Loop Code Addresses

| Equip. Manuf. | Model | IOR Addresses | ILR Addresses | Maint. Switch/ Ramp Address |
|---------------|--|---|---|--------------------------------|
| Wescom | F-Series Office | A to H, J to M, 0 to 2, AA to AH, AJ to AM, A0 to A2 | A to H, J to M, 0 to 2, AA to AH, AJ to AM A0 to A2 | N/A |
| | F-Series Field (CS270F/3192-7F/3423-7F) | | | |
| Westell | 3150-C0 | N/A | 1 to 99 | N/A |
| | 3130-56/3150-56 | 1 to 2 | 1 to 20 | N/A |
| | 3151-56 | N/A | 1 to 20 | N/A |
| | 3130-70/3150-70 | 1 to 2 | 1 to 20 | N/A |
| | 3130-80/3150-80 | 1 to 2 | 0 to 1999 | N/A |
| | 3140-80 | 0 to 1999 | N/A | N/A |
| | 3150-81 | N/A | 0 to 1999 | N/A |
| | NIMS-20, NIMS-28, NIMS-60 | N/A | N/A | 1 to 28 |



Table D-1 (Continued)
Intelligent Network Equipment Loop Code Addresses

| Equip. Manuf. | Model | IOR Addresses | ILR Addresses | Maint. Switch Ramp Address |
|---------------|-----------------------------------|---------------|--|----------------------------|
| Westell | 3222/3224-00(01) (HDSL equip.) | None | None | N/A |
| XEL | 7853-000 | N/A | Exchange Code: 1 to 9999 Location Code: 1 to 999 | N/A |
| | 7854-008 | N/A | 1 to 63 | N/A |

NOTE: N/A indicates there is no equipment of that type associated with the given model of equipment.



Table D-2
Intelligent Network Equipment Commands

| Equip. Manuf. | Model | Equip. Commands | Program Command | Command Selections |
|---------------|-------------------------|---|-----------------|--------------------|
| ADTRAN | HDSL equip., No Model # | Arm/Disarm, Time-out Disable | N/A | N/A |
| | HDSL equip., No Model # | Arm/Disarm, Query, Time-out Disable, Power Down | N/A | N/A |
| Teltrend | HDSL equip., No Model # | Arm/Disarm, Time-out Disable | N/A | N/A |
| | 7231/7239 | Arm/Disarm | N/A | N/A |
| | 7231/7239LC | Near-end Arm | | |
| | 7231/7239LD | Query, Time-out Disable, Power Loop, Power Down, Power Thru | | |





Table D-2 (Continued)
Intelligent Network Equipment Commands

| Equip. Manuf. | Model | Equip. Commands | Program Commands | | Command Selections |
|------------------|--|--|------------------|--------------------|--------------------|
| | | | Program Commands | Command Selections | |
| TxPORT Wescom | 231/239 | N/A | N/A | N/A | N/A |
| | F-Series Office or F-Series Field (CS270F/3192-7F/ 3423-7F) | Time-Out Disable, Power Loop, Power Query | N/A | N/A | N/A |
| Westell | 3150-C0 | Arm/Disarm, Query, Time-out Disable, Seq. Loopback | N/A | N/A | N/A |
| | 3130-56/3150-56 | Arm/Disarm, Query, Time-out Disable, Seq. Loopback, Power Query | N/A | N/A | N/A |



Table D-2 (Continued)
Intelligent Network Equipment Commands

| Equip. Manuf. | Model | Equipment Commands | Program Commands | Command Selections |
|---------------|-----------------|---|---|---|
| Westell | 3151-56 | Arm/Disarm, Query, Time-out Disable, N/A | N/A | N/A |
| | 3130-70/3150-70 | Seq. Loopback, Power Query, AIS Disable Arm/Disarm, CPE Arm, Query, Time-out Disable, Option Query | ArmFrame, AIS, Program Address Timeout Block CPE Arm Acknowledge Arm Code Reset | Auto, Dual, ESF Enable, Disable 1 to 2 Enable, Disable Enable, Disable Error, Invert CPE, NIU Master, Session |



Table D-2 (Continued)
Intelligent Network Equipment Commands

| Equip. Manuf. | Model | Equipment Commands | Program Commands | Command Selections |
|---------------|--|--|---|--|
| Westell | 3130-80/3150-81 or 3140-80 or 3150-81 | Arm/Disarm, Query, Time-out Disable, Seq. Loopback, Power Query, AIS Disable, Option Query | Program Address Arm Frame Code Detection AIS, Timeout Reset | 0/1 to 1999 Auto, Dual, ESF Sync, Async Enable, Disable Enable, Disable Master, Session |
| | NIMS-20 NIMS-28 NIMS-60 | N/A | N/A | N/A |
| XEL | 3222/3224-00(01) (HDSL equip.) | Arm/Disarm, Time-out Disable | N/A | N/A |
| | 7853-000 | Time-out Extend | N/A | N/A |
| | 7854-008 | N/A | N/A | N/A |

NOTE: Some Commands are only valid for the office repeaters, and some commands are only valid for the line repeaters.



INDEX

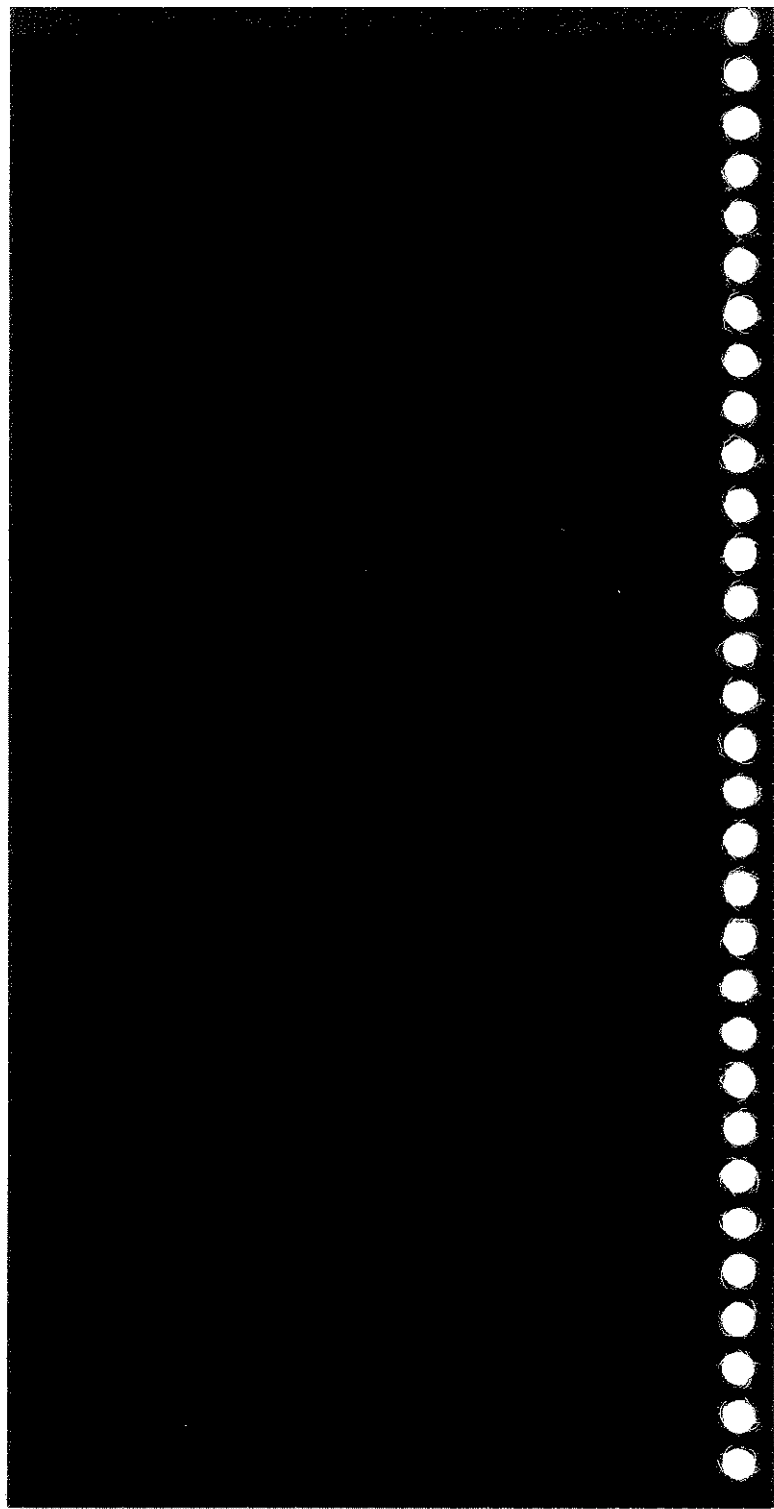



INDEX

Symbols

1:1 Test Pattern 3-10
1:7 Test Pattern 3-10
120-Octet Pattern 3-40
2 IN 8 Test Pattern 3-10
2047-Bit Test Pattern 3-57
3 IN 24 Test Pattern 3-11
511-Bit Test Pattern 3-57
53-Octet Pattern 3-40
54-Octet Pattern 3-40
55-Octet Pattern 3-39, 3-41
63-Bit Test Pattern 3-57
72-Octet Pattern 3-41
8-Pin DIN-Type Connector 3-34
96-Octet Pattern 3-39



Accessories 1-5
 PR-40A Thermal Printer 1-6, 1-7
 T-BERD Repeater Power Supply 1-6
 T-BERDT1 Repeater Extender 1-5
Addressable Repeater Loop Codes 7-13
Advanced Stress Patterns Option 1-4, 3-39
 Patterns 1
 Test Patterns 3-39
AIS LED 3-28
Alarm
 Criteria 7-8
 LEDs. *See* Alarm LEDs
 Maintenance Test 5-10, 5-23
 Major 5-8, 5-22
 Messages 3-37, 3-38, 5-1, 5-3, 5-8, 5-22, 6-16



Minor 5-9, 5-23
Power/Miscellaneous 5-9, 5-23
Shelf 5-8, 5-22
AlarmLEDs 3-26, 7-8
History 3-26
ALL ONES Test Pattern 3-10
ALL ZERO Test Pattern 3-14
AMI Coding 3-15
ANSI T1.403 ESF Circuits 3-43
AUTOLLB Mode 3-9, 4-9
AUTO Mode 3-6
Automatic Configure Mode 3-6
AUX AUTO RESP Function 3-56, 4-9
AUX BAUD Function 6-3
AUX BUF CLR Function 4-46, 6-7
AUX CH DROP Function 5-17
AUX CLOCK Function 4-52
AUX ESF LOOP Function 4-5
AUX FT1 CHAN Function 3-56, 4-57
AUX FT1 IDLE Function 3-56, 4-50, 4-52, 4-54
AUX FT1 RATE Function 3-56, 4-56
AUX LOOP CODE Function 3-53, 3-56, 4-7, 4-15
AUX MULTIPAT Function 4-5
AUX PGMLPDN Function 4-13
AUX PGMLPUP Function 4-10
AUX PRIEVNT Function 4-47, 6-6
AUX PRINTV Function 4-48, 4-49, 6-6
AUX PRINT Function 4-44, 6-5
AUX PRM Function 3-45
AUX PRNTPORT Function 4-50
AUX SMARTNET Function 4-33
AUX Switch 3-16, 3-53
AUX TERM 232 Function 6-3
AUX TEST LEN Function 4-43



- AUX TIME TST Function 4-41
- AUX USER Function 4-4
- AUX VF CHAN Function 4-38
- AUX VF TONE Function 4-59
- AUX VOLUME Function 4-40
- Auxiliary Functions
 - FT1 Option 3-56
- B**
- B8ZS
 - Coding 3-15, 3-26
 - LED 3-15, 3-26
 - Switch 3-15
- Battery
 - Low Battery LED 3-28
 - Specifications 7-14
- BATTERY CHARGE Test Results 5-20
- BITERR RATE Test Results 5-12
- BITERR SEC Test Results 5-12
- BITERRORS Test Results 5-4, 5-12
- BPV RATE Test Results 5-13
- BPV SECONDS Test Results 5-13
- BRIDGE Input Termination. *See* RX INPUT Switch
- BRIDGTAP
 - Printouts 6-9
- BRIDGTAP Test Pattern 3-11
- C**
- CATEGORY Switch 3-22, 3-47
- Channel 1
 - Time Slot Assignments 3-7, 1
- Continuous Test. *See* AUX TIME TST Function 4-41
- Controls Printout 6-16
- CRCERR RATE Test Results 5-12



CRCERR SEC Test Results 5-12
CRCERRORS Test Results 5-4, 5-12

D

D4 Superframe
 FT1 Mode 3-55
Data Communications Equipment (DCE) 6-1
Data Terminal Equipment (DTE) 6-1
Datalink
 Alarm Field 5-22
 Alarm Seconds 5-21
DATALINK Category 3-36, 5-3, 5-20
Default Settings 1
Definition
 Loop Codes 7-12
DISPL LIGHT Switch 3-22
Display 3-4
DS1 Maintenance Switch 4-27
 Ramp Code 4-27
 Switch Code 4-27
DSX-MON Input Termination. *See* RXINPUT
Switch

E

ELAPSE TIME Test Results 5-19
Enhanced ESF Option 1-4, 2-14, 3-43
 Installation Verification 2-14
 Test Results 5-10
ERR INS Switch 3-33
ERRORS Category 3-24, 5-12
Excess Zeros LED 3-27, 7-9
Extended Superframe
 ESF Datalink Loop Codes 4-29
 FT1 Mode 3-55



F

Factory Default Settings. See Default Settings 1

Factory Defaults 1, 2

FAR BPV SEC Test Results 5-11

FAR CRCERR Test Results 5-11, 5-24

FAR FRMES Test Results 5-10

FAR FRM SES Test Results 5-11

FAR SLP SEC Test Results 5-11, 5-24

FCRC >319 Test Results 5-25

FCRC 1 Test Results 5-24

FCRC 101-319 Test Results 5-25

FCRC 11-100 Test Results 5-25

FCRC 2-5 Test Results 5-24

FCRC 6-10 Test Results 5-25

Fractional T1 Option 1-5

Installation Verification 2-18

Frame Loss LED 3-26, 7-8

Frame Sync LED 3-25

FRMERR RATE Test Results 5-13

FRMERR SEC Test Results 5-13

FRM ERRORS Test Results 5-13

FT1 D4 Mode 3-55

FT1 ESF Mode 3-55

FT1 Option

Auxiliary Functions 3-56

Operating Modes 3-55

H

HIST RESET Switch 3-28

History Alarm LEDs. See Alarm LEDs

I

In-Warranty Service 2-22



L

- LBO Switch 3-19
- LoopCode Switches 3-30, 3-54
 - LOOPCODES Switch 3-30
 - LOOPDOWN Switch 3-32, 3-58
 - LOOPUP Switch 3-31, 3-58
- LoopCodes
 - Addressable Repeater LoopCodes 7-13
 - Auxiliary Functions 3-30
 - DS2 Maintenance Switch Commands 4-28
 - ESF datalink 4-29
 - HDSL 4-29
 - Intelligent Line Repeater 4-18
 - Intelligent Office Repeater 4-18
 - Intelligent Repeater Commands 4-19
 - Programmed 4-11, 4-13
 - Remote Programming Commands 4-25
- Loop Down LED 3-32
- Loop Up LED 3-31
- Low Battery LED 3-28, 7-9

M

- Major Alarm. *See* Alarm 5-8
- Messages
 - Alarm. *See* Alarm Messages
 - Status 6-18
 - SUMMARY Category 3-28, 5-5
- MIN/MAX Test Pattern 3-41
- Minor Alarm. *See* Alarm 5-9
- MODE Switch 3-5, 3-55
- Modes, Operating. *See* Pgs. 3-5—3-9
 - Enhanced ESF Option 3-43
 - Fractional T1 Option 3-55
 - SLC Datalink Decode Option 3-35
- MULTIPAT
 - Printouts 6-11
 - Test Pattern 3-13, 4-5



N

NOTFOR SYNC Test Results 5-7, 5-20

O

Ones Density LED 3-27

Operating Modes 3-6

AUTOLLB Mode 4-9, 4-42, 4-48

FT1 Option 3-55

Options

Advanced Stress Patterns 1-4

Channel Monitor Option 7-6

Enhanced ESF 1-4, 2-14, 3-43

Fractional T1 1-5, 2-18

Oscillator, internal 3-16

Out-of-Warranty Service 2-23

Overflow Printout 6-14

P

Pattern Loss LED 3-27

PATTERN Switch 3-10, 3-39, 3-44, 3-57

Pattern Sync LED 3-25

Patterns

1 Pattern 7-10

2 IN 8 Pattern 7-10

55 OCTET Pattern 3-15, 7-11

7 Pattern 7-10

ALL ZERO Pattern 7-11

BRIDGTAP Pattern 7-10

Definitions 7-10

MIN/MAX 9

MULTIPAT Pattern 7-11

PGMPAT1 Pattern 3-14, 3-15

PGMPAT2 Pattern 3-14, 3-15

PGMPAT3 Pattern 3-14, 3-15

QRSS Pattern 7-10

Stress 1



- T1 DALY Pattern 3-15, 7-11
- T1-2 (96-Octet) 4
- T1-3 (54-Octet) 7
- T1-4 (120-Octet) 9
- T1-5 (53-Octet) 12
- T1-6 (55-Octet) 14
- T1-DALY 16
- PAY SRC Test Results 5-26
- PR-40A Thermal Printer 1-6, 1-7, 6-4
- Pre-Existing Loop LED 3-33
- Print Buffer 4-46
- Print Event Functions. See AUXPRIEVNT
Function 4-47
- PRINT Switch 3-51
- Printer
 - Buffer 4-46, 6-7
 - Parameters 6-2
 - PR-40A 6-1, 6-4
 - Serial 6-1
 - Squelch Control 6-15
- PRINTER Connector 3-34, 6-1, 7-7
- Printer Squelch 6-15
- Printouts 6-7
 - BRIDGTAP 6-9
 - Controls 4-44, 6-6, 6-16
 - Generation 6-5
 - MULTIPAT 6-11
 - Overflow 6-14
 - Results 4-47, 4-49, 6-6, 6-8
 - SMARTNIU 3-51, 6-12
- Programmable
 - Loop-Down Code. See Loop Codes
 - Loop-Up Code. See Loop Codes
 - Test Patterns 3-14, 4-4
- PWR/MISC Alarm. See Alarm 5-9



Q

QRSS Test Pattern. *See* T1-QRSS Test Pattern

R

RCVD Switch 3-16

REF Jack 3-20

Repair 2-24

RESTART Switch 3-22, 3-45

Results Printouts. *See* Printouts

RESULTS Switch 3-23

RS-232 Printer Interface. *See* PRINTER Connector

RX INPUT Switch 3-18

RX Jack 3-20

S

SELF TST Mode 3-6

Shelf Alarm. *See* Alarm

SIG LOS SEC Test Results 5-19

Signal Alarm LEDs. *See* Alarm LEDs

SIGNAL Category 3-24, 5-2, 5-15

Signal Levels 5-15

Signal Loss LED 3-26, 7-8

Signal Status LEDs. *See* Status LEDs

Simplex Current 5-16

SLC Datalink Decode Option 3-35

Test Results 5-20

SLC-96

Channel Time Slot Assignment 1

Datalink 3-35

SLC-M1 Mode 3-35

SLC-M2 Mode 3-35

SMART NIU

Mode 3-43

Results Printout. *See* Printouts



SONET Test Results 5-7, 5-20
Speaker 4-40
Status LEDs 3-25
STRATUM 1 Test Results 5-7, 5-20
STRATUM 2 Test Results 5-7, 5-21
STRATUM 3 Test Results 5-7, 5-21
STRATUM 4 Test Results 5-7, 5-21
SUMMARY Category 3-23, 5-1, 5-4
SUMMARY Category Messages. *See* Messages
SYNC UNKNOWN Test Results 5-7, 5-21

T

T-BERD Repeater Power Supply 1-6
T-BERD T1 Repeater Extender 1-5
T1 DID Mode 3-8
T1 D4 Mode 3-7
T1 DALY Test Pattern 3-39
T1 ESF Mode 3-7
T1 LLB Mode 3-8
T1 Mode 3-7
T1 Pulses LED 3-25
T1 SLC Mode 3-7
T1 TLB Mode 3-8
T1-2/96 Test Pattern 3-39
T1-3/54 Test Pattern 3-40
T1-4/120 Test Pattern 3-40
T1-5/53 Test Pattern 3-40
T1-QRSS Test Pattern 3-11
Temperature 7-1
TERM Input Termination. *See* RXINPUT Switch
TESTENDIN Test Results 5-19
TestLength
 Timed 4-41, 4-43



TEST LENGTH Test Results 5-19

Test Patterns. *See* Pgs. 3-9—3-13

Advanced Stress Patterns Option. *See* Pgs. 3-39
—3-41

Test Results 3-48

DATALINK Category 3-38, 5-3, 5-20

ERRORS Category 3-24, 5-12

SIGNAL Category 3-24, 5-2, 5-15

SUMMARY Category 3-23, 3-37, 5-1, 5-4

TIME Category 3-24, 5-2, 5-19

TIME Category 3-24, 5-2, 5-19

Time Slot Assignments. *See* Channel 1

Timed Test. *See also* AUX TIME TST Function
4-41

Timing Slips. *See* SIGNAL Category 5-16

TRAFFIC Results 5-17

TX Jack 3-20

U

USER Test Patterns 3-14

USER Test Results 5-8, 5-21

V

VFO OUT Jack 3-20

VF Tones 3-57

VIOLATIONS Test Results 5-4, 5-13

Volume. 4-40

Volume. *See* AUX VOLUME Function 4-40

W

Warranty Policy 2-22

Y

Yellow Alarm LED 3-27

